

Technical Report

TR-14-04

Engineered Barrier Process Report for the Safety Assessment SR-PSU

Svensk Kärnbränslehantering AB

August 2014

Svensk Kärnbränslehantering AB

Swedish Nuclear Fuel
and Waste Management Co

Box 250, SE-101 24 Stockholm
Phone +46 8 459 84 00



ISSN 1404-0344

SKB TR-14-04

ID 1404091

Engineered Barrier Process Report for the Safety Assessment SR-PSU

Svensk Kärnbränslehantering AB

August 2014

Preface

This report gives an account of how processes in the engineered barriers important for the long-term evolution of the SFR repository for nuclear waste. The report forms part of the SR-PSU safety assessment, which supports SKB's licence application to extend SFR.

Most of the material in the report was contributed by selected experts in the field; see Section 1.7 for a complete list of contributors.

The report has been reviewed by; Jordi Bruno, Amphos 21, Russell Alexander, Bedrock Geosciences, Per Mårtensson, SKB, Kristina Skagius, SKB, and Henrik von Schenk, SKB.

Stockholm, November 2014

Fredrik Vahlund

Project leader SR-PSU

Summary

The final repository for short-lived radioactive waste (SFR) located in Forsmark, Sweden is currently being used for the final disposal of low- and intermediate-level operational waste from Swedish nuclear facilities. SKB plans to extend the repository to host waste from the decommissioning of the nuclear power plants. The SR-PSU assessment of the long-term safety (post-closure safety) of the whole repository is an important part of the application for a licence to build the extension. This process report constitutes one of the main references supporting the Main report, which summarises the long-term safety for SFR.

Processes that are expected to take place in the near field of SFR in the period up to 100,000 years post-closure are systematically documented in two process reports, including an evaluation of the importance of each process within the SR-PSU and a suggestion of how the process should be handled in the SR-PSU activities. This report addresses processes in the technical barriers in the repository. The other process report for the near field treats the processes related to the waste package, i.e. the waste form and packaging. The process reports support the description of the repository long term reference evolution.

This report consists of two main chapters describing the waste form processes and the packaging processes respectively.

Sammanfattning

Slutförvaret för kortlivat radioaktivt avfall (SFR) i Forsmark, Sverige används för närvarande för slutlig deponering av låg- och medelaktivt driftavfall från svenska kärntekniska anläggningar. SKB planerar att bygga ut förvaret för att förvara avfall från rivning av kärnkraftverken. Analysen av långsiktig säkerhet SR-PSU (säkerhet efter förslutning) för hela förvaret är en viktig del av ansökan om att få bygga ut förvaret. Den här processrapporten utgör en av huvudreferenserna till huvudrapporten som summerar analysen av långsiktig säkerhet för SFR.

Processer som förväntas ske i närzonen i SFR under 100 000 år efter förslutning dokumenteras systematiskt i två processrapporter, vilken inkluderar utvärdering av varje process betydelse och förslag om hur processen ska hanteras inom SR-PSU. Den här rapporten behandlar de tekniska barriärerna i förvaret. Den andra processrapporten för närzonen behandlar processer för avfallskollin, dvs avfallsformen och emballage. Processrapporterna är en viktig del i underlaget för beskrivningen av förvarets referensutveckling.

Rapporten är indelad i två huvudkapitel som beskriver de relevanta processerna för avfallsformen samt avfallspaketen.

Contents

1	Introduction	11
1.1	Background	11
1.2	Report hierarchy in the SR-PSU safety assessment	12
1.3	This report	12
1.4	System components	14
1.5	Variables	14
1.6	Processes	14
1.7	Participating experts	14
2	Repository system	17
2.1	Design and closure of the repository	17
2.2	1BMA, vault for intermediate-level waste	19
2.3	2BMA, vault for intermediate-level waste	20
2.4	1BTF and 2BTF, vaults for concrete tanks	23
2.5	Silo	25
2.6	1BLA, vault for low-level waste	28
2.7	2–5BLA, vaults for low-level waste	30
2.8	BRT, vault for reactor pressure vessels	31
2.9	Plugs and other closure components	32
3	Safety functions	35
3.1	Introduction	35
3.2	Engineered barriers – hydraulic barrier function	35
3.2.1	BLA	35
3.2.2	BRT	36
3.2.3	BTF	36
3.2.4	BMA	36
3.2.5	Silo	37
3.2.6	Plugs and other closure components	37
3.3	Temperature	38
3.4	Engineered barriers – chemical barrier function	38
4	Processes and system variables	39
4.1	Structure for process description	39
4.2	Introduction to the system variables	41
4.2.1	Definition of the BMA system and variables	41
4.2.2	Definition of the BTF system and variables	41
4.2.3	Definition of the Silo system and variables	41
4.2.4	Definition of the BLA system and variables	42
4.2.5	Definition of the BRT system and variables	43
4.2.6	Definition of the system plugs and and other closure components	43
4.3	Introduction to the processes	43
5	1–2BMA	45
5.1	Thermal processes	45
5.1.1	Heat transport	45
5.1.2	Phase changes/freezing	47
5.2	Hydraulic processes	51
5.2.1	Water uptake and transport during unsaturated conditions	51
5.2.2	Water transport under saturated conditions	56
5.2.3	Gas transport/dissolution	58
5.3	Mechanical processes	66
5.3.1	Mechanical processes	66
5.4	Chemical processes	70
5.4.1	Advection and dispersion	70
5.4.2	Diffusion	76

5.4.3	Sorption on concrete/shotcrete	82
5.4.4	Sorption on crushed rock backfill	88
5.4.5	Colloid stability, transport and filtering	91
5.4.6	Concrete degradation	99
5.4.7	Aqueous speciation and reactions	115
5.4.8	Microbial processes	121
5.4.9	Metal corrosion	128
5.4.10	Gas formation	134
5.5	Radionuclide transport	139
5.5.1	Speciation of radionuclides	139
5.5.2	Transport of radionuclides in the water phase	141
5.5.3	Transport of radionuclides in the gas phase	144
6	1BTF and 2BTF	147
6.1	Thermal processes	147
6.1.1	Heat transport	147
6.1.2	Phase changes/freezing	148
6.2	Hydraulic processes	149
6.2.1	Water uptake and transport during unsaturated conditions	149
6.2.2	Water transport under saturated conditions	152
6.2.3	Gas transport/dissolution	154
6.3	Mechanical processes	155
6.3.1	Mechanical processes	155
6.4	Chemical processes	160
6.4.1	Advection and dispersion	160
6.4.2	Diffusion	161
6.4.3	Sorption	162
6.4.4	Colloid stability, transport and filtering	164
6.4.5	Concrete degradation	165
6.4.6	Aqueous speciation and reactions	166
6.4.7	Microbial processes	167
6.4.8	Metal corrosion	168
6.4.9	Gas formation	169
6.5	Radionuclide transport	170
6.5.1	Speciation of radionuclides	170
6.5.2	Transport of radionuclides in the water phase	171
6.5.3	Transport of radionuclides in the gas phase	172
7	Silo	173
7.1	Thermal processes	173
7.1.1	Heat transport	173
7.1.2	Phase changes/freezing	174
7.2	Hydraulic processes	177
7.2.1	Water uptake and transport during unsaturated conditions	177
7.2.2	Water transport under saturated conditions	180
7.2.3	Gas transport/dissolution	183
7.2.4	Piping/erosion	189
7.3	Mechanical processes	193
7.3.1	Mechanical processes	193
7.4	Chemical processes	200
7.4.1	Advection and dispersion	200
7.4.2	Diffusion	203
7.4.3	Sorption (including ion-exchange of major ions)	208
7.4.4	Alteration of impurities	214
7.4.5	Colloid transport and filtering	217
7.4.6	Dissolution/Precipitation	219
7.4.7	Concrete degradation	221
7.4.8	Aqueous speciation and reactions	223
7.4.9	Osmosis	225

7.4.10	Montmorillonite transformation	227
7.4.11	Iron–bentonite interaction	231
7.4.12	Montmorillonite colloid release	233
7.4.13	Microbial processes	235
7.4.14	Cementation in bentonite	239
7.4.15	Metal corrosion	240
7.4.16	Gas formation	241
7.5	Radionuclide transport	242
7.5.1	Speciation of radionuclides	242
7.5.2	Transport of radionuclides in the water phase	244
7.5.3	Transport of radionuclides in the gas phase	245
8	1–5BLA	247
8.1	Thermal processes	247
8.1.1	Heat transport	247
8.1.2	Phase changes/freezing	248
8.2	Hydraulic processes	249
8.2.1	Water uptake and transport under unsaturated conditions	249
8.2.2	Water transport under saturated conditions	250
8.2.3	Gas transport/dissolution	252
8.3	Mechanical processes	252
8.3.1	Mechanical processes	252
8.4	Chemical processes	253
8.4.1	Advection and dispersion	253
8.4.2	Diffusion	257
8.4.3	Sorption	257
8.4.4	Colloid stability, transport and filtering	258
8.4.5	Aqueous speciation and reactions	258
8.4.6	Microbial processes	262
8.4.7	Degradation of rock bolts, reinforcement and concrete	264
8.5	Radionuclide transport	265
8.5.1	Speciation of radionuclides	265
8.5.2	Transport of radionuclides in the water phase	265
8.5.3	Transport of radionuclides in the gas phase	267
9	BRT	269
9.1	Thermal processes	269
9.1.1	Heat transport	269
9.1.2	Phase changes/freezing	270
9.2	Hydraulic processes	271
9.2.1	Water uptake and transport during unsaturated conditions	271
9.2.2	Water transport under saturated conditions	272
9.2.3	Gas transport/dissolution	274
9.3	Mechanical processes	275
9.3.1	Mechanical processes	275
9.4	Chemical processes	279
9.4.1	Advection and dispersion	279
9.4.2	Diffusion	280
9.4.3	Sorption	280
9.4.4	Colloid stability, transport and filtering	283
9.4.5	Concrete degradation	283
9.4.6	Aqueous speciation and reactions	284
9.4.7	Microbial processes	289
9.4.8	Metal corrosion	291
9.4.9	Gas formation	292
9.5	Radionuclide transport	293
9.5.1	Speciation of radionuclides	293
9.5.2	Transport of radionuclides in the water phase	294
9.5.3	Transport of radionuclides in the gas phase	295

10	Plugs and other closure components	297
10.1	Thermal processes	297
10.1.1	Heat transport	297
10.1.2	Phase changes/freezing	298
10.2	Hydraulic processes	299
10.2.1	Water uptake and transport during unsaturated conditions	299
10.2.2	Water transport under saturated conditions	302
10.2.3	Gas transport/dissolution	304
10.2.4	Piping/erosion	307
10.3	Mechanical processes	310
10.3.1	Mechanical processes	310
10.4	Chemical processes	314
10.4.1	Advection and dispersion	314
10.4.2	Diffusion	315
10.4.3	Sorption (including ion-exchange of major ions)	316
10.4.4	Alteration of impurities in bentonite	317
10.4.5	Dissolution, precipitation, recrystallisation and clogging in backfill	318
10.4.6	Aqueous speciation and reactions	322
10.4.7	Osmosis	323
10.4.8	Montmorillonite transformation	324
10.4.9	Montmorillonite colloid release	324
10.4.10	Microbial processes	325
10.4.11	Degradation of rock bolts, reinforcement and concrete	325
10.5	Radionuclide transport	326
10.5.1	Speciation of radionuclides	326
10.5.2	Transport of radionuclides in the water phase	327
10.5.3	Transport of radionuclides in the gas phase	327
	References	329

1 Introduction

1.1 Background

The final repository for short-lived radioactive waste (SFR) located in Forsmark, Sweden is used for the final disposal of low- and intermediate-level operational waste from Swedish nuclear facilities. SKB plans to extend SFR to host waste from the decommissioning of the nuclear power plants and other nuclear facilities. Additional disposal capacity is needed also for operational waste from nuclear power units in operation since their operation life-times have been extended compared with what was originally planned.

The SFR repository includes waste vaults underground together with buildings above ground that include a number of technical installations. The underground part of the existing facility (SFR 1) is situated at 60 metres depth in the rock and is located below the Baltic Sea. The existing facility (SFR 1) comprises five waste vaults with a disposal capacity of approximately 63,000 m³. The extension (SFR 3¹) will be built at 120 metres depth and will have a disposal capacity of 108,000 m³ in five new waste vaults plus one new vault for nine boiling water reactor pressure vessels, see Figure 1-1.

The long-term post closure safety of the whole SFR has been assessed and documented in the SR-PSU Main report with supporting documents, see Section 1.2. The Main report is part of SKB's licence application to extend and continue to operate SFR. The present report is a main reference and describes thermal, hydraulic, mechanical, chemical and biological processes acting within the engineered barriers in SFR that are relevant for the long-term safety of the repository.

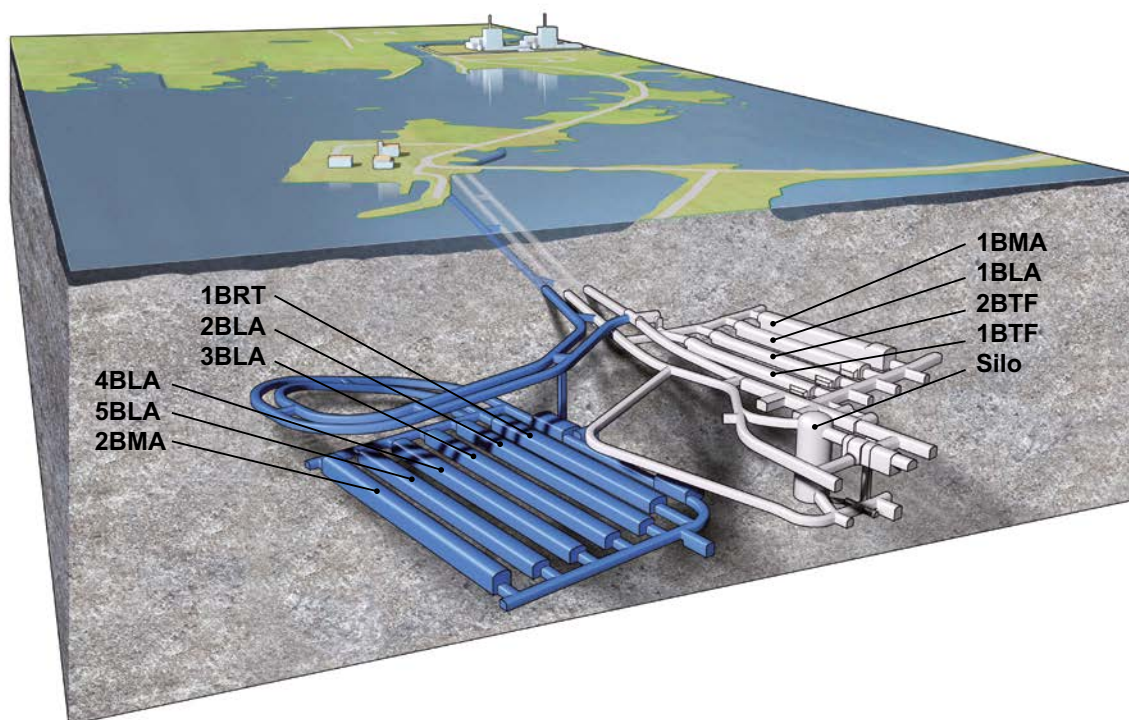

Figure 1-1. Schematic illustration of SFR. The grey part is the existing repository (SFR 1) and the blue part is the planned extension (SFR 3). The waste vaults in the figure are the silo for intermediate-level waste, 1–2BMA vaults for intermediate-level waste, 1–2BTF vaults for concrete tanks, 1–5BLA vaults for low-level waste and the BRT vault for reactor pressure vessels.

¹ The extension is called SFR 3 since the name SFR 2 was used in a previous plan to build vaults adjacent to SFR 1 for disposal of reactor core components and internal parts. The current plan is to dispose of this waste in a separate repository.

1.2 Report hierarchy in the SR-PSU safety assessment

The applied methodology for the long-term safety comprises ten steps and is described in Chapter 2 of the Main report of SR-PSU. Several of the steps carried out in the safety assessment are described in more detail in supporting documents, so called Main references that are of central importance for the conclusions and analyses in the Main report. The full titles of these reports together with the abbreviations by which they are identified in the following text (**abbreviated names in bold font**) together with short comments on the report contents are given in Table 1-1.

There are also a large number of additional references. The additional references include documents compiled within SR-PSU, but also documents compiled outside of the project, either by SKB or equivalent organisations as well as in the scientific literature. Additional publications and other documents are referenced in the usual manner.

A schematic illustration of the safety assessment documents is shown in Figure 1-2.

1.3 This report

The long term safety assessment for SFR (SR-PSU) is performed according to a developed methodology including ten steps (see Chapter 2 in the Main Report). This report focuses on assessment Step 4 – Description of internal processes.

The purpose of this process report is to document the scientific knowledge and handling of the processes in the engineered barriers of the repository system that has been identified to be relevant for the long term safety in a previous assessment step, Step 1 – Handling of FEP's (features, events and processes).

The documentation of the processes is not exhaustive from a scientific point of view, since such a treatment is neither necessary for the purposes of the safety assessment nor possible within the broad scope of the assessment. However, it must be sufficiently detailed to justify the handling of each process in the safety assessment and the associated uncertainties. The handling approaches established in this report will be used in subsequent steps in the applied assessment methodology, mainly the analysis of the reference evolution, Step 7, and the analyses of scenarios, Step 9.

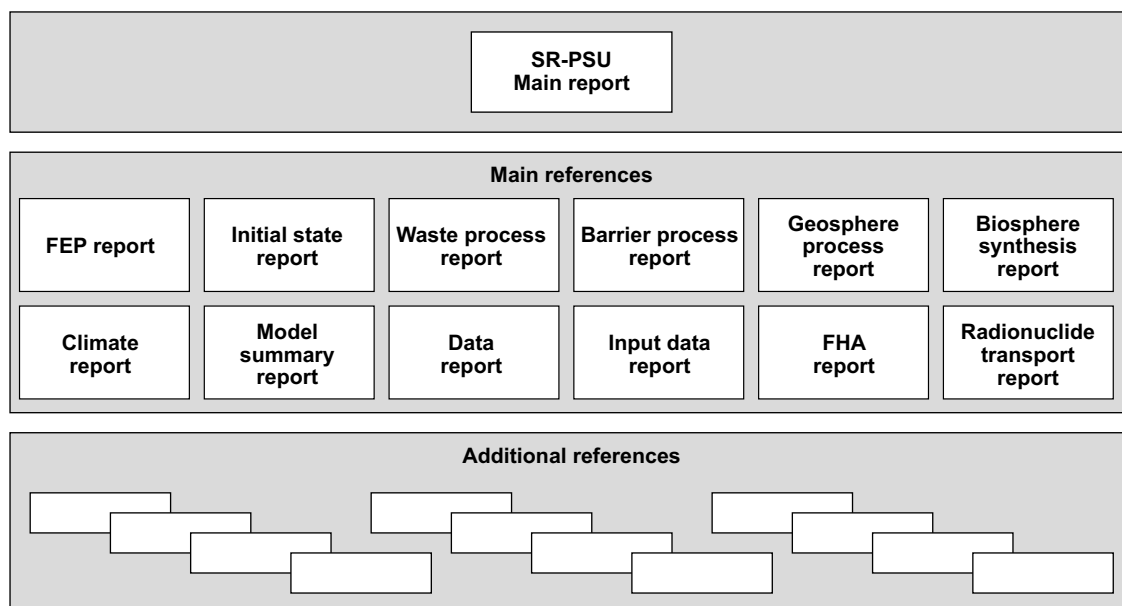

Figure 1-2. The hierarchy of the Main report, Main references and additional references in the SR-PSU long-term safety assessment. The additional references either support the Main report or any of the Main references.

Table 1-1. Main report and Main references in the SR-PSU long term safety assessment.
All reports are available at www.skb.se

Abbreviation used when referenced in this report	Text in reference list	Comment on content
Main report	Main report, 2014. Safety analysis for SFR. Long-term safety. Main report for the safety assessment SR-PSU. SKB TR-14-01, Svensk Kärnbränslehantering AB.	This document is the main report of the SR-PSU long-term post-closure safety assessment for SFR. The report is part of SKB's licence application to extend and continue to operate SFR.
Barriers process report	Engineered barriers process report, 2014. Engineered barrier process report for the safety assessment SR-PSU. SKB TR-14-04, Svensk Kärnbränslehantering AB.	Describes the current scientific understanding of the processes in the engineered barriers that have been identified in the FEP processing as potentially relevant for the long-term safety of the repository. Reasons are given in the process report as to why each process is handled a particular way in the safety assessment.
Biosphere synthesis report	Biosphere synthesis report, 2014. Biosphere synthesis report for the safety assessment SR-PSU. SKB TR-14-06, Svensk Kärnbränslehantering AB.	Describes the handling of the biosphere in the safety assessment. The report summarises site description and landscape evolution, FEP handling, exposure pathway analysis, the radionuclide model for the biosphere, included parameters, biosphere calculation cases and simulation results.
Climate report	Climate report, 2014. Climate and climate-related issues for the safety assessment SR-PSU. SKB TR-13-05, Svensk Kärnbränslehantering AB.	Describes the current scientific understanding of climate and climate-related processes that have been identified in the FEP processing as potentially relevant for the long-term safety of the repository. The report also describes the climate cases that are analysed in the safety assessment.
Data report	Data report, 2014. Data report for the safety assessment SR-PSU. SKB TR-14-10, Svensk Kärnbränslehantering AB.	Qualifies data and describes how data, including uncertainties, that are used in the safety assessment are quality assured.
FEP report	FEP report, 2014. FEP report for the safety assessment SR-PSU. SKB TR-14-07, Svensk Kärnbränslehantering AB.	Describes the establishment of a catalogue of features, events and processes (FEPs) that are of potential importance in assessing the long-term functioning of the repository.
FHA report	FHA report, 2014. Handling of future human actions in the safety assessment SR-PSU. SKB TR-14-08, Svensk Kärnbränslehantering AB.	Describes radiological consequences of future human actions (FHA) that are analysed separately from the main scenario, which is based on the reference evolution and less probable evolutions.
Geosphere process report	Geosphere process report, 2014. Geosphere process report for the safety assessment SR-PSU. SKB TR-14-05, Svensk Kärnbränslehantering AB.	Describes the current scientific understanding of the processes in the geosphere that have been identified in the FEP processing as potentially relevant for the long-term safety of the repository. Reasons are given in the process report as to why each process is handled a particular way in the safety assessment.
Initial state report	Initial state report, 2014. Initial state report for the safety assessment SR-PSU. SKB TR-14-02, Svensk Kärnbränslehantering AB.	Describes the conditions (state) prevailing in SFR after closure. The initial state is based on verified and documented properties of the repository and an assessment of the evolution during the period up to closure.
Input data report	Input data report, 2014. Input data report for the safety assessment SR-PSU. SKB TR-14-12, Svensk Kärnbränslehantering AB.	Describes the activities performed within the SR-PSU safety assessment and the input data used to perform these activities.
Model summary report	Model summary report, 2014. Model summary report for the safety assessment SR-PSU. SKB TR-14-11, Svensk Kärnbränslehantering AB.	Describes the calculation codes used in the assessment.
Radionuclide transport report	Radionuclide transport report, 2014. Radionuclide transport and dose calculations for the safety assessment SR-PSU. SKB TR-14-09, Svensk Kärnbränslehantering AB.	Describes the radionuclide transport calculations carried out for the purpose of demonstrating fulfilment of the criterion regarding radiological risk.
Waste process report	Waste process report, 2014. Waste form and packaging process report for the safety assessment SR-PSU. SKB TR-14-03, Svensk Kärnbränslehantering AB.	Describes the current scientific understanding of the processes in the waste and its packaging that have been identified in the FEP processing as potentially relevant for the long-term safety of the repository. Reasons are given in the process report as to why each process is handled in a particular way in the safety assessment.

1.4 System components

According to the instructions (SKBdoc 1196630). The whole repository system is divided into system components. A system component is a physical component of the repository system, a sub-system. The system components treated in this report are:

- BMA (including future rock vault for intermediate level waste (2BMA)).
- 1BTF and 2BTF.
- The Silo.
- BLA , including future vaults for low level waste (2–5BLA).
- Rock vault for reactor pressure vessels, BRT.

A definition is given in different sections in Chapter 3.

Within each major system component there are subsystem components. As an example the Silo is the major system component and it is divided into subsystem components such as concrete and bentonite.

1.5 Variables

According to the instructions (SKBdoc 1196630). A list of physical variables for the system components should be established. Physical variables are parameters that are required to describe the properties and conditions in a system component.

A list of variables for the different system components are given in different sections in Chapter 3.

1.6 Processes

According to the instruction (SKBdoc 1196630). A list of processes for the system components should be established. Processes are thermal, hydraulic, mechanical and chemical (biological processes are included in the chemical and treated as one process) acting within the repository system. The list of processes is developed by the experts in cooperation with the manager of the FEP database. This list is mainly based on the processes identified in earlier safety assessment of the SFR facility, the FEP-work conducted for SR-PSU (**FEP report**), and in the Buffer, backfill and closure process report for SR-Site (SKB 2010a). For the bentonite, all processes in the Buffer, backfill and closure process report for SR-Site are included, except the radiation related process Radiation attenuation/heat generation.

1.7 Participating experts

The experts involved in assembling the basic information on the processes are listed in Table 1-2. All these experts are included in the SR-PSU list of experts as required by the SR-PSU QA plan, see further the **Main report**.

Table 1-2. List of experts for the processes.

Process	Expert author, affiliation
Heat transport	Martin Birgersson, Clay Technology
Phase changes/freezing	Martin Birgersson, Clay Technology
Water uptake and transport during unsaturated conditions	Lennart Börgesson, Clay Technology
Water transport under saturated conditions	Lennart Börgesson, Clay Technology
Gas transport/dissolution	Lars Olof Höglund, Kemakta
Mechanical processes	Lennart Börgesson, Clay Technology
Advection and dispersion (Concrete)	Lars Olof Höglund, Kemakta
Diffusion (Concrete)	Lars Olof Höglund, Kemakta
Sorption	Michael Ochs, BMG
Colloid stability, transport and filtering (Concrete)	Magnus Sidborn, Kemakta
Concrete degradation	Lars Olof Höglund, Kemakta
Aqueous speciation and reactions (Concrete)	Miranda Keith-Roach, Kemakta
Microbial processes	Birgitta Kalinowski, SKB
Metal corrosion	Marie Wiborgh, Kemakta
Gas formation	Marie Wiborgh, Kemakta
Speciation of radionuclides	Michael Ochs, BMG
Transport of radionuclides in the water phase	Per-Gustav Åstrand, Facilia
Transport of radionuclides in the gas phase	Per-Gustav Åstrand, Facilia
Piping/erosion	Lennart Börgesson, Clay Technology
Advection and dispersion (bentonite)	Michael Ochs, BMG
Diffusion (bentonite)	Michael Ochs, BMG
Alteration of impurities	Michael Ochs, BMG
Colloid transport and filtering (bentonite)	Michael Ochs, BMG
Dissolution/Precipitation	Michael Ochs, BMG
Aqueous speciation and reactions (bentonite)	Michael Ochs, BMG
Osmosis	Michael Ochs, BMG
Iron–bentonite interaction	Michael Ochs, BMG
Montmorillonite colloid release	Michael Ochs, BMG
Cementation in bentonite	Michael Ochs, BMG

2 Repository system

2.1 Design and closure of the repository

SFR is designed as a subsea hard rock facility that is reached via access tunnels from a surface facility. SFR 1 comprises a silo and four waste vaults for different waste categories. The waste vaults are located about 60 m beneath the surface of the sea. The bottom of the silo is located much deeper, however, about 130 m beneath the sea surface. SFR 3 is planned to contain six waste vaults. The waste vaults in the new part will be located about 120 m beneath the sea surface, which means that they will be at the level of the silo bottom, see Figure 2-1. The designated levels in the figure are given in RHB 70 which is the Swedish geographical height system. Today there are two access tunnels and in order to enable whole reactor pressure vessels (RPVs) to be emplaced in the repository, a third access tunnel is planned.

The facility will be decommissioned when all waste has been deposited. When the decision on final shutdown has been taken, decommissioning of the facility will begin and continue until the repository has been closed and sealed. A carefully designed decommissioning plan, centred on the closure sequence, will be drawn up in good time before the closure works begin. Demolition and dismantling of existing systems will then be coordinated with the execution of closure. After decommissioning and closure, the repository is a passive system that can be left without further measures having to be taken to maintain proper function. Facilities above ground will be decontaminated and used for other purposes or demolished.

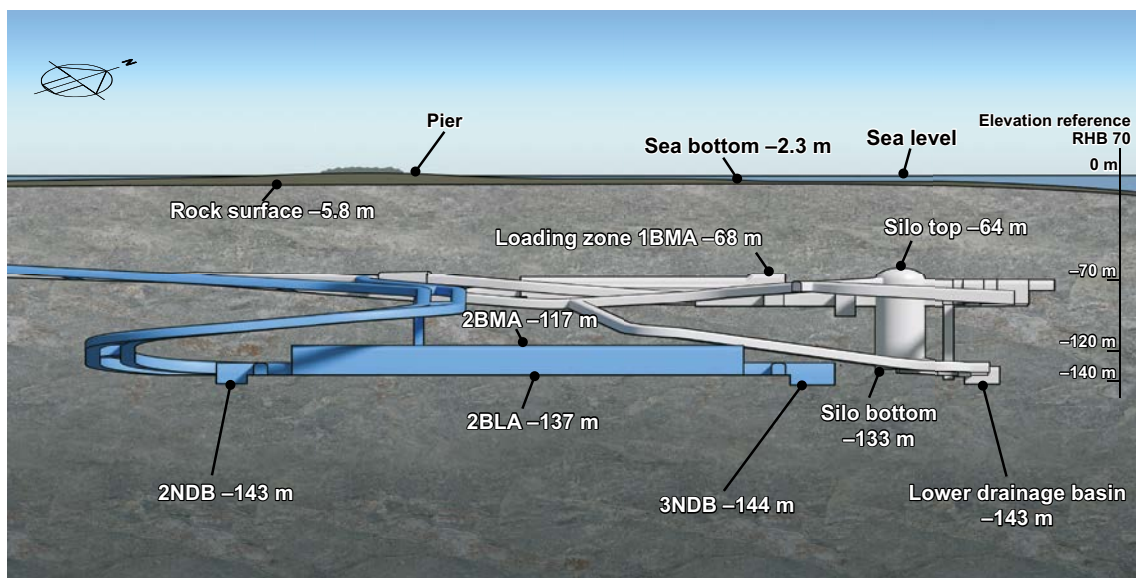

Figure 2-1. View of SFR with designated levels in RHB 70 (RHB 70 is the Swedish geographical height system). Note that stipulated elevations for the top surface of the rock and the sea floor are to be regarded as approximate since they are point data and vary in the plane above SFR. The grey part is SFR 1 and the blue part is SFR 3.

Closure

Closure includes installation of backfill material and plugs at selected locations in the underground facility. The primary purpose is to reduce the flow of water through the waste and impede human intrusion into the repository. Plugs are to be installed in access tunnels and connecting shafts, and all tunnels are to be backfilled with macadam². The upper part of the access tunnels is to be filled with stone blocks and sealed with concrete plugs. Finally, the ground surface will be restored to blend in with the surrounding landscape. In addition, all boreholes at SFR will be sealed so that the water flow in the surrounding rock is not affected by them.

A summary description of the repository after closure is provided in the following sections. The planned closure measures are described in greater detail in the closure plan for SFR (SKBdoc 1358612).

An overall picture of the closed repository is shown in Figure 2-2. The plug sections are hydraulically tight sections with bentonite that is held in place by mechanical constraints. Wherever warranted by the geometry of the tunnels and the properties of the rock, concrete plugs are installed as mechanical constraints. Where this is not suitable, a mechanical constraint consisting of backfill and transition material is installed instead. The role of the transition material is to hinder bentonite transport out from the hydraulic tight section, to take up the load from bentonite swelling and transfer it to the backfill material. The backfill material consists of macadam and the transition material of 30/70 bentonite/crushed rock. A mechanical constraint of backfill and transition material together with a tight section of bentonite is called an earth dam plug.

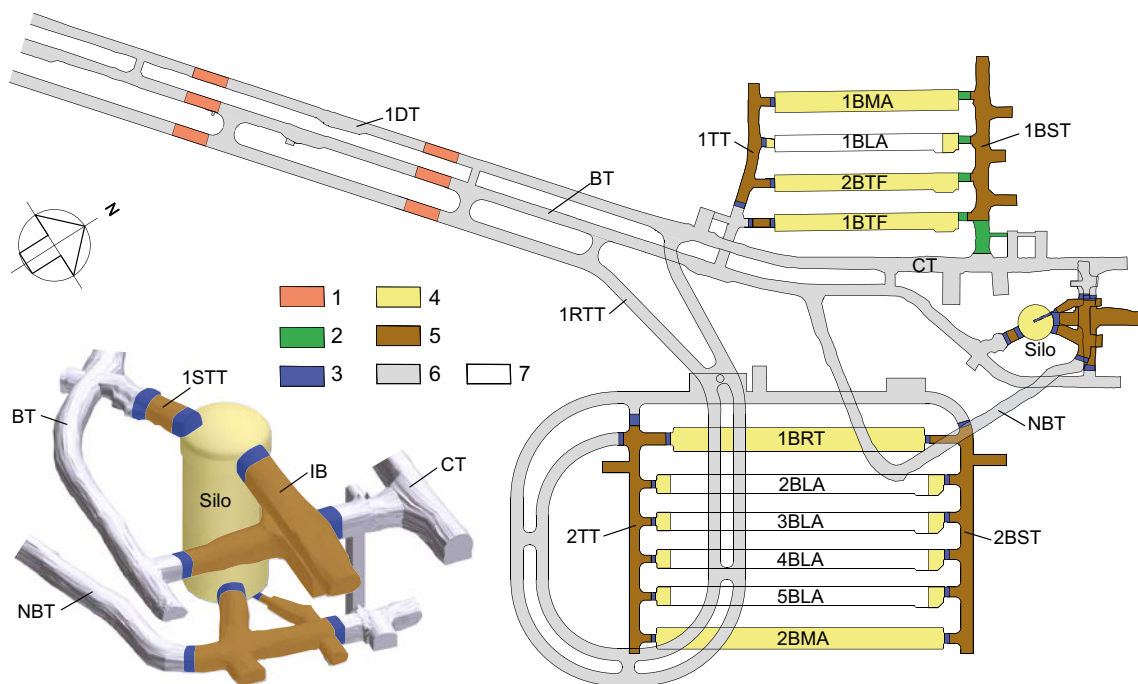

Figure 2-2. Schematic plan of SFR 1 and SFR 3, with a detailed view of the silo. Key to numbering: 1) Plugs in access tunnels 2) Transition material 3) Mechanical constraint of concrete 4) Backfill material of macadam 5) Hydraulically tight section of bentonite 6) Backfill material in access tunnels and the central area of the tunnel system 7) Non-backfilled openings. Note that the figure shows Layout 2.0; Layout 1.5 is used in SR-PSU modelling. The only difference relevant to this figure is that BRT is longer here than in Layout 1.5. The labels in the figure will be referred to in the text.

² Macadam is crushed rock sieved in fractions 2–65 mm. Macadam has no or very little fine material (grain size < 2mm). The fraction is given as intervals, for example “Macadam 16–32” is crushed rock with fraction 16–32 mm.

2.2 1BMA, vault for intermediate-level waste

The waste vault is approximately 20 m wide, 17 m high and 160 m long. The waste is deposited in an approximately 140 m long reinforced concrete structure divided into 13 large compartments and two smaller compartments. The loadbearing parts of the concrete structure are founded on solid rock and the bottom slab on a base of crushed rock levelled with gravel. The walls and roof in the vault are lined with shotcrete. The bottom slab, walls and floor structures are made of in situ cast reinforced concrete. To keep the moulds in place during casting penetrating form rods made out of steel was used (Figure 2-3). The walls and roof of the rock vault are lined with shotcrete. A prefabricated concrete lid is put in place after the compartments are filled with waste. The lids provide radiation shielding and fire protection. Another concrete layer is cast on top of the prefabricated lids to give the structure added stability and tightness.

In the compartments, concrete and steel moulds, as well steel drums (on a drum tray or in a drum box) are deposited by a remote-controlled overhead crane that runs on the top edge of the walls of the concrete structure, see Figure 2-4. The waste is deposited as it arrives at SFR; moulds are stacked six high and drums eight high. As the compartments are filled, they are temporarily closed with thick radiation-shielding prefabricated concrete elements. At least two rows of concrete moulds are installed in each compartment to support the prefabricated concrete elements.



Figure 2-3. Examples of form rods.

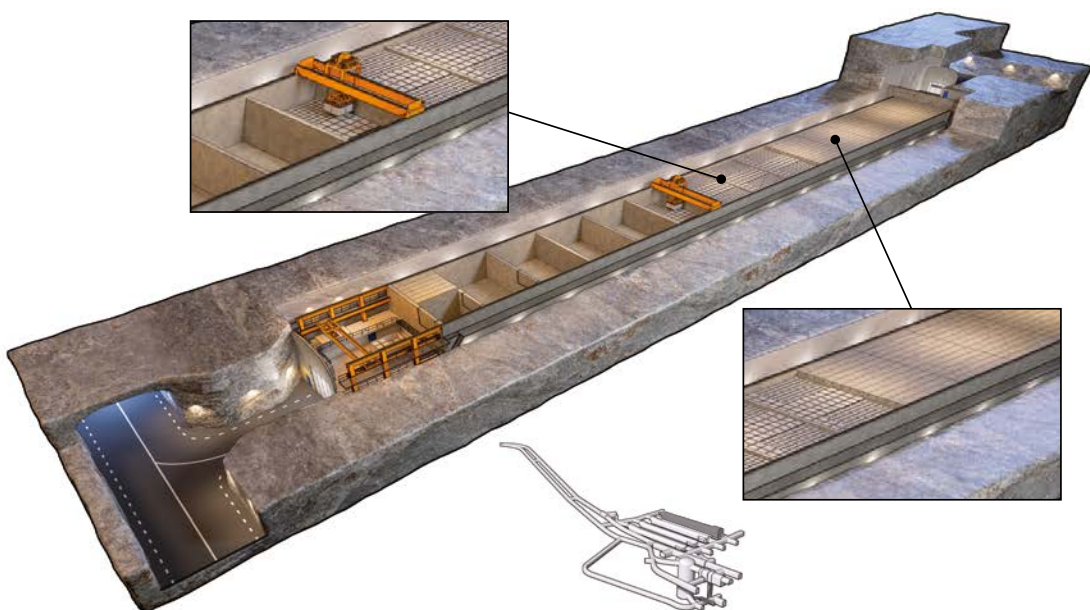

Figure 2-4. Vault for intermediate-level waste, 1BMA, in SFR 1 during the operating phase.

Closure

An extensive programme for investigation of the concrete structure has been carried out and has revealed that extensive repair and reinforcement measures need to be adopted to achieve the desired hydraulic and mechanical properties at closure. The closure plan for SFR (SKBdoc 1358612) describes the planned measures for closure of 1BMA.

Prior to closure and after operations have been concluded, the waste packages in the compartments are embedded in grout and a reinforced concrete lid is cast on top of the prefabricated concrete elements. Installations and equipment in the vault are removed and the space between the concrete structure and the rock wall is backfilled with macadam, see Figure 2-5. At the end of the waste vault that connects to the transverse tunnel (1TT), a concrete plug is installed as a mechanical constraint for the bentonite in the tunnel. It is not possible to install a concrete plug in the connection to the waste vault tunnel (1BST); instead, here the mechanical constraint for the bentonite consists of a section with transition material and backfill material in the waste vault, see Figure 2-5 and Figure 2-6.

2.3 2BMA, vault for intermediate-level waste

SFR 3 includes an approximately 20 m wide, 16 m high (16.8 m in Layout 1.5) and 275 m long vault for intermediate-level waste. Experience from 1BMA has been utilised in the design of the disposal room in 2BMA. 14 free-standing unreinforced concrete caissons with a base of 16×16 m and a height of more than 8 m are to be built in the waste vault. The concrete caissons will be founded on a base of crushed rock levelled with gravel, and the walls and roof will be lined with shotcrete.

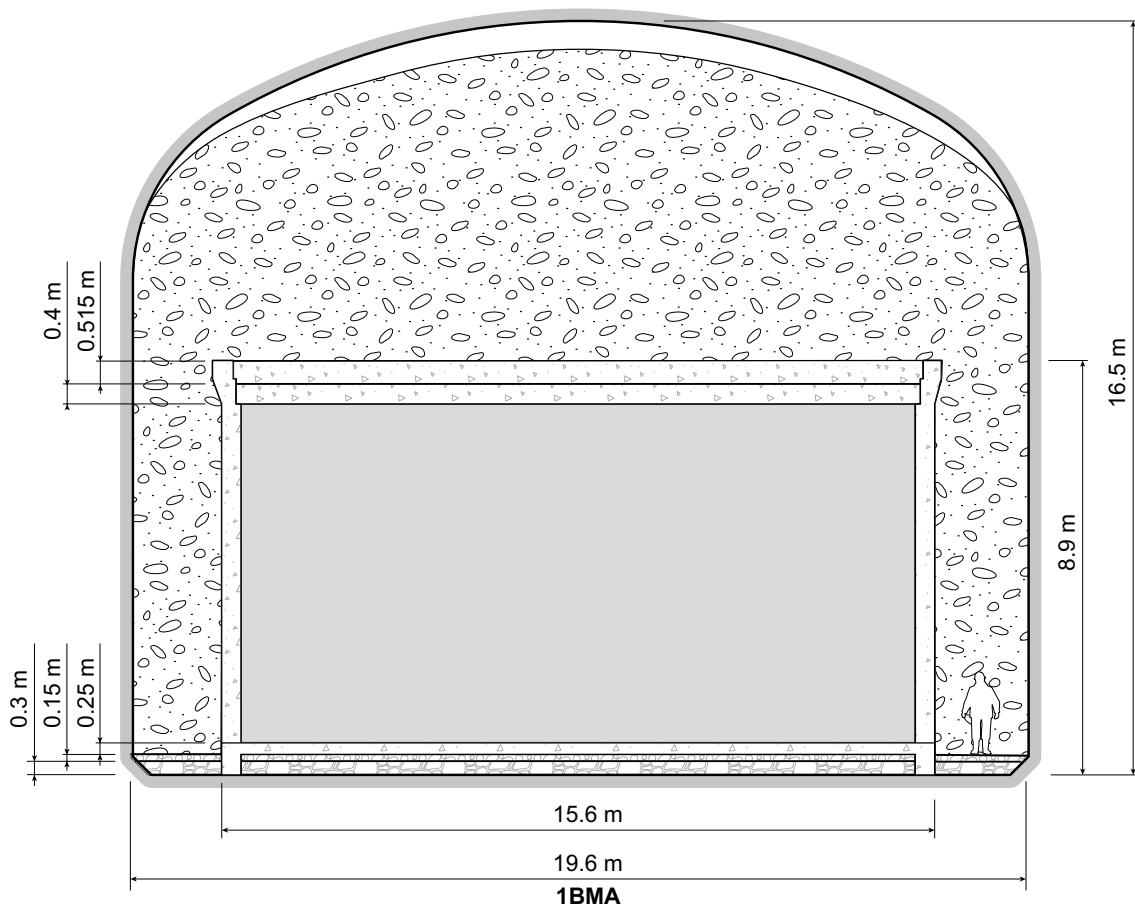

Figure 2-5. Schematic cross-section of 1BMA after closure.

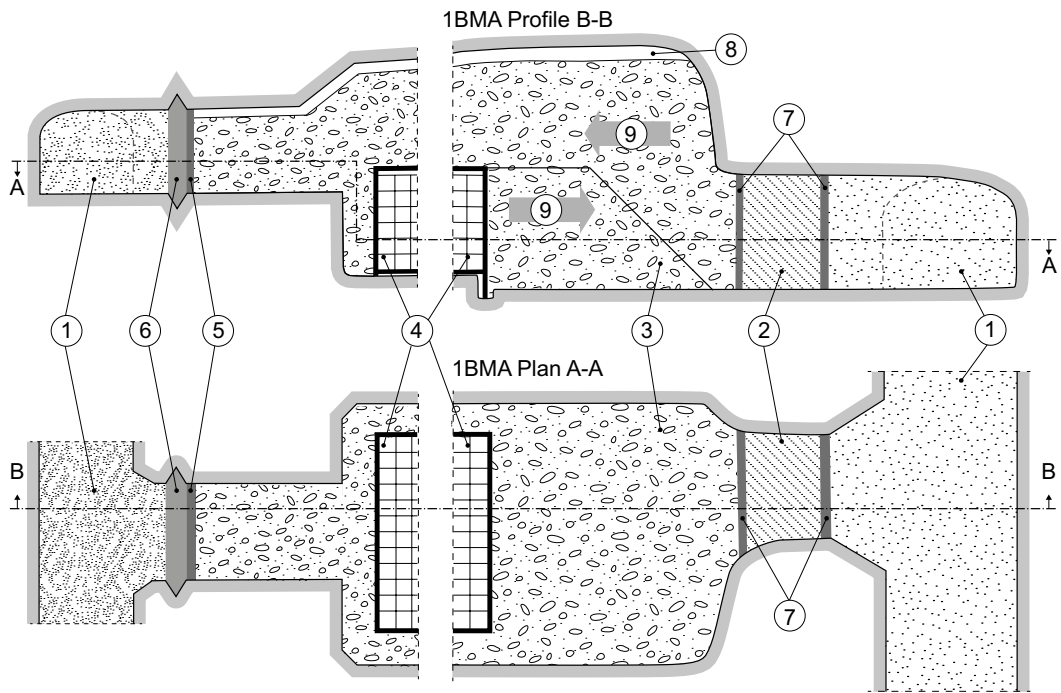

Figure 2-6. Profile and plan of 1BMA after closure. Key to numbering: 1) Bentonite 2) Transition material, e.g. 30/70 mixture of bentonite and crushed rock 3) Macadam 4) Grouted waste packages 5) Constraining wall and concrete form 6) Mechanical plug of concrete 7) Constraining wall of concrete for transition material 8) Open gap between top surface of macadam and tunnel roof 9) Working direction for backfilling of waste vault.

Waste packages in the form of steel and concrete moulds will be deposited in each caisson by a remote-controlled overhead crane. The overhead crane runway will be separated from the caissons, see Figure 2-7. Grouting of the waste packages will be done continuously during operation. The size of the caissons ensures sufficient spacing between each 4-mould unit for the embedment grout. This also ensures that the grout will make a contribution to the total loadbearing capacity of the caissons. If needed, prefabricated concrete elements will be placed on top of the caissons to serve as radiation shielding during the operating phase.

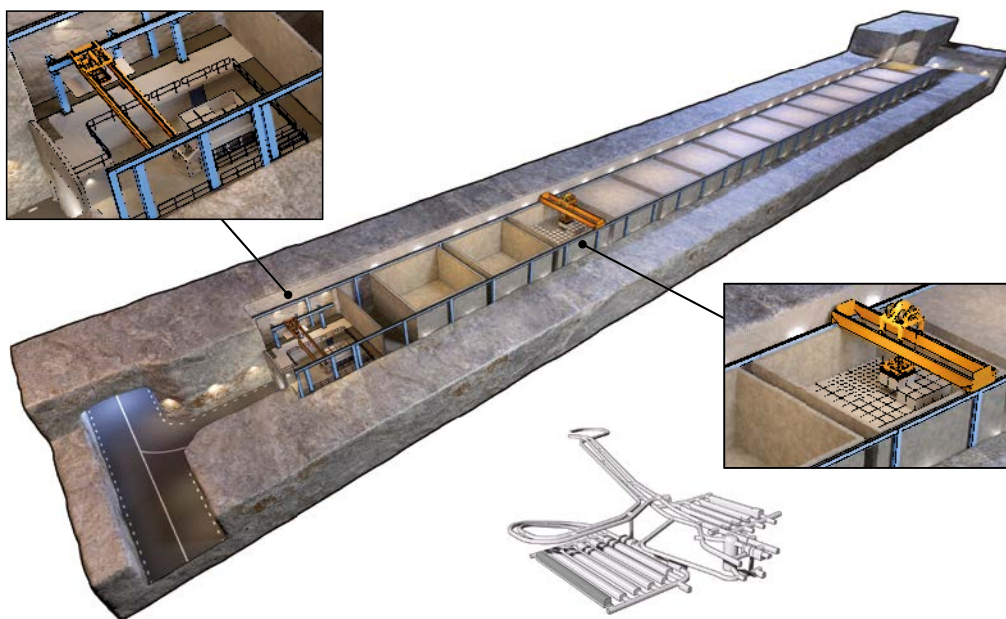

Figure 2-7. Vault for intermediate-level waste, 2BMA, in SFR 3 during the operating phase.

Closure

The closure plan for SFR (SKBdoc 1358612) describes the planned measures for closure of 2BMA. The prefabricated concrete elements are removed prior to closure and instead an unreinforced concrete lid is cast on top of the grout-embedded waste in the caisson. The shrinkage gap formed between walls and lid will act as a vent pathway for gas formed due to corrosion of metals in the waste packages. Installations and equipment in the waste vault are removed and the space between caissons as well as between caissons and the rock wall is backfilled with macadam, see Figure 2-8. The geometry of the waste vault is such that concrete plugs can be installed at both ends of the waste vault as mechanical constraints for the bentonite in connecting tunnels, see Figure 2-9.

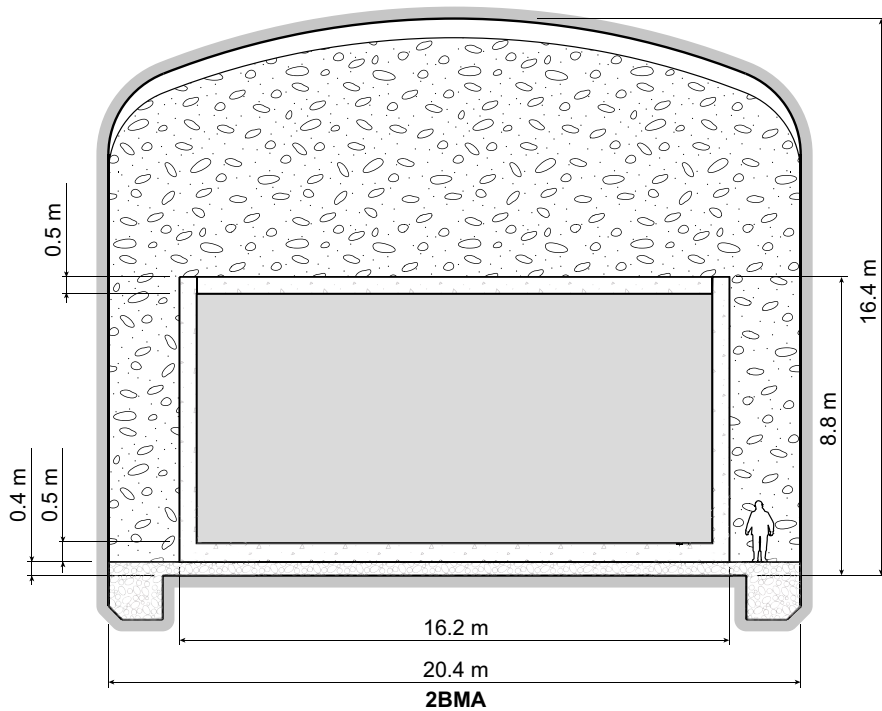

Figure 2-8. Schematic cross-section of 2BMA after closure. Note that the figure shows Layout 2.0; Layout 1.5 is used in SR-PSU modelling. The concrete structure has the same dimensions in Layout 1.5, but the width of the vault is 19.8 m and the height is 16.8 m.

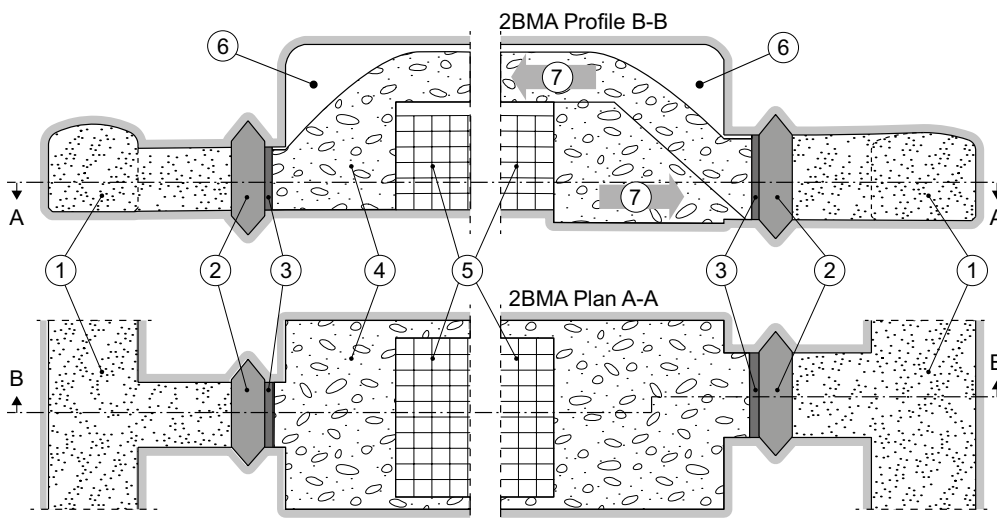

Figure 2-9. Schematic profile and plan of 2BMA after closure. Key to numbering: 1) Bentonite 2) Mechanical plug of concrete 3) Constraining wall and concrete form 4) Macadam 5) Grouted waste packages 6) Open gap between top surface of macadam and tunnel roof 7) Working direction for backfilling of waste vault.

2.4 1BTF and 2BTF, vaults for concrete tanks

The two waste vaults 1BTF and 2BTF are approximately 15 m wide, 9.5 m high and 160 m long. The vaults are primarily designed for disposal of dewatered ion-exchange resins in concrete tanks. The walls and roof of the vaults are lined with shotcrete. The concrete floors are cast on a draining foundation and surrounded by a 1 m high baseboard along the rock wall. To facilitate the planned grouting of the concrete tanks, a number of concrete pillars are cast on the baseboard; see the illustration at the bottom of Figure 2-10 and Figure 2-11.

Besides concrete tanks, drums containing ashes from incineration at Studsvik as well as miscellaneous types of waste such as a reactor pressure vessel head are also deposited in 1BTF. To provide support for the drums with ashes in 1BTF, concrete tanks are positioned in the tunnel direction and partition walls are built up of concrete moulds with low activity content and low surface dose rate; see the illustration at the top of Figure 2-10. Grouting of ash drums is done progressively during operations.

Only concrete tanks are placed in 2BTF. The tanks are positioned four abreast and two in height, after which prefabricated concrete elements are placed on top as radiation shielding, see Figure 2-11.

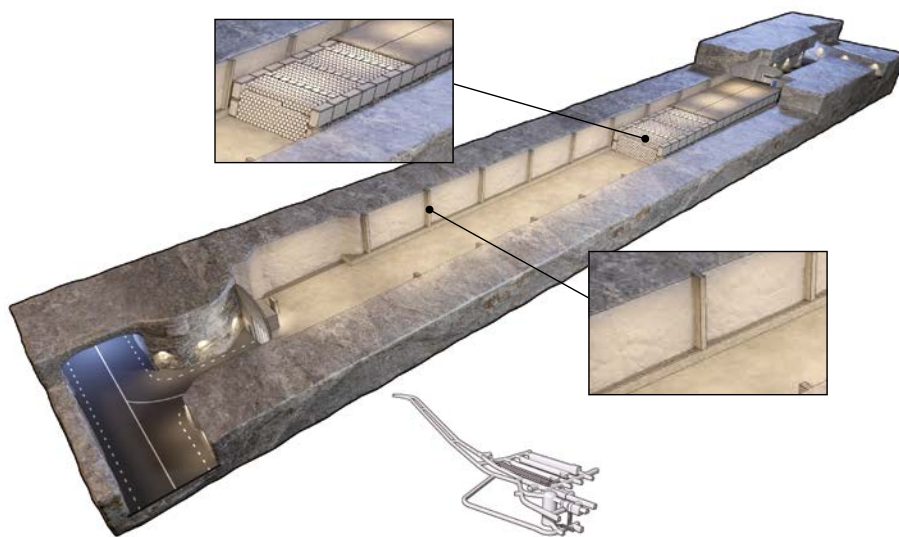

Figure 2-10. Vault for concrete tanks, 1BTF, in SFR 1 during the operating phase. The top part illustrates emplacement of ash drums.

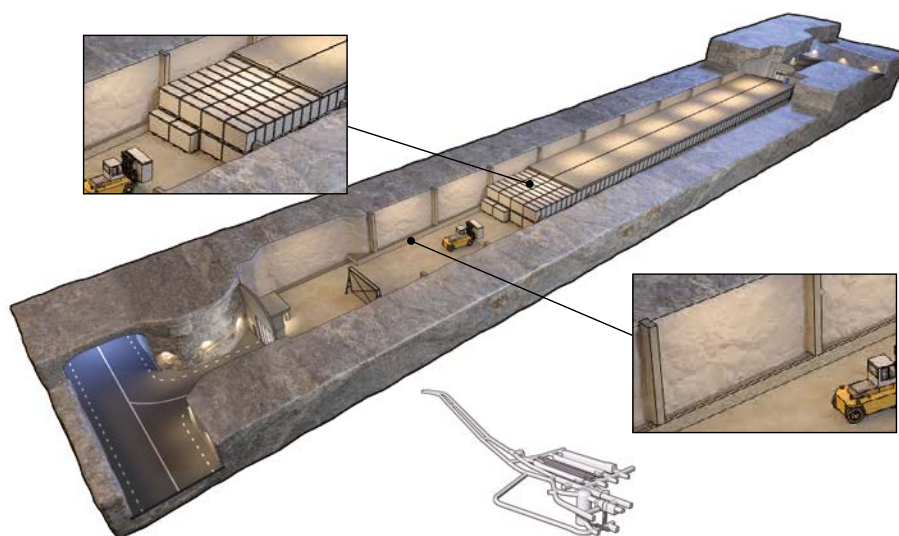

Figure 2-11. Vault for concrete tanks, 2BTF, in SFR 1 during the operating phase. The top part illustrates the emplacement of concrete tanks.

Closure

The closure plan for SFR (SKBdoc 1358612) describes the planned measures for closure of 1BTF and 2BTF. The space between concrete tanks and rock wall is filled with grout as the first step in closure of the waste vaults. In 2BTF with only concrete tanks, the spaces between the concrete tanks are filled with grout in the next step, and on top of the prefabricated concrete elements a concrete slab is cast to bear the weight of the macadam. In 1BTF, the ash drums in the inner half of the waste vault are already grouted, and the outer half with only concrete tanks is grouted in the same way as in 2BTF. Finally, the space above the grout and the concrete slab is filled with macadam up to the roof and the waste vaults are plugged in the same way as 1BMA, see Section 2.2.

Figure 2-12 and Figure 2-13 show schematic illustrations of 1BTF and 2BTF after closure. The aim with the new rock profile is to increase the contact area between the macadam and the rock and thereby increase the mechanical support for the transition material in the plug.

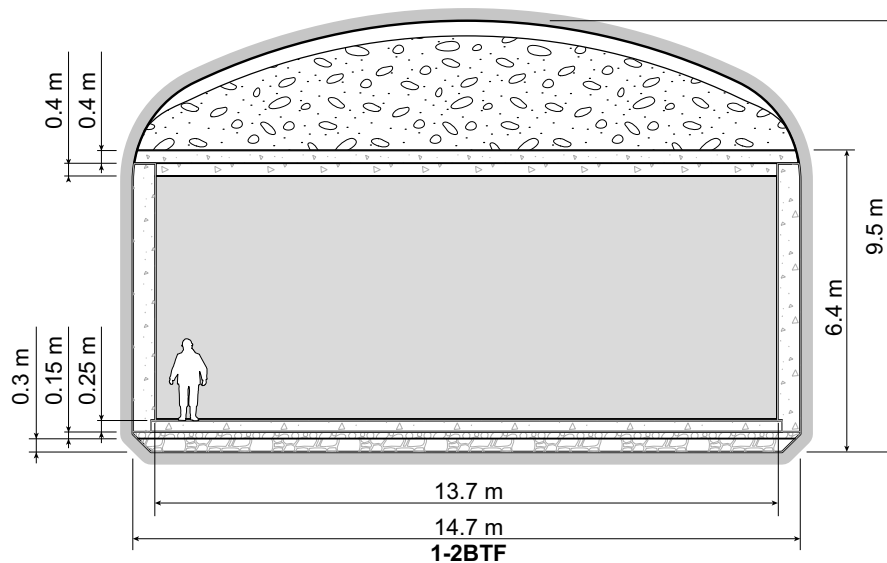

Figure 2-12. Schematic cross-section of 1BTF and 2BTF after closure.

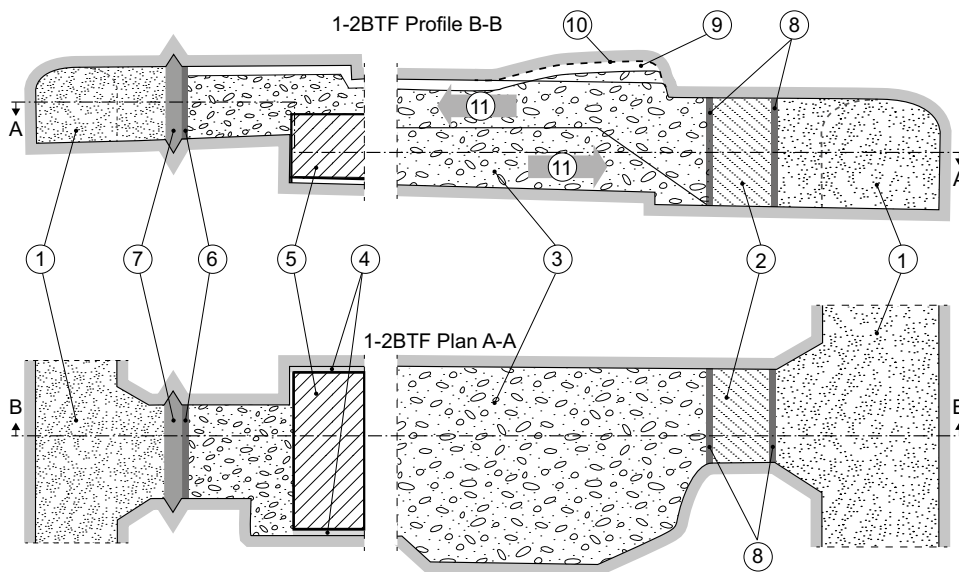

Figure 2-13. Schematic profile and plan of 1BTF and 2BTF after closure. Key to numbering: 1) Bentonite 2) Transition material 3) Macadam 4) Concrete between waste and rock wall 5) Grouted waste packages 6) Constraining wall and concrete form 7) Concrete plug 8) Constraining wall 9) Open gap between top surface of macadam and tunnel roof 10) New rock profile 11) Working direction for backfilling of waste vault.

2.5 Silo

The silo is a cylindrical vault in which a free-standing concrete cylinder has been built. The silo vault is about 70 m high with a diameter of about 30 m. The concrete cylinder is made of in situ cast concrete and the concrete bottom slab is founded on a bed of 90% sand and 10% bentonite. The concrete cylinder is divided into a number of vertical shafts, and the gap between the concrete cylinder and the rock is filled with bentonite. The bentonite is a sodium conditioned bentonite with the product name GEKO/Q10 from Süd-Chemie in Deutschland. Figure 2-14 shows a picture of the bentonite in the top of the silo, taken during a sampling of the bentonite. The material composition of the bentonite has been tested and XRD show a typical bentonite with a high content of dioctahedral smectite and low levels of accessory minerals (Figure 2-15). Rietveld refinement using the Siroquant software indicated 84.5% montmorillonite (std av. 0.6, Table 2-1). XRD for the clay fraction (not included) showed no signs of any accessory minerals, indicating that the illite/mica reflection most likely was mica ($> 2 \mu\text{m}$). A full documentation is given in the **Initial state report**.

The rock walls are lined with shotcrete, and a rock drainage system is installed between the bentonite and the rock.

Table 2-1. XRD quantification of phases.

XRD Bulk Phase	1	2	3	Average	Std dev
Montmorillonite (CP)	84.4	85.1	83.9	84.5	0.6
Quartz	0	0.1	0.6	0.2	0.3
Anorthite	1.2	1	0.5	0.9	0.4
Cristobalite	0.3	0.4	0.3	0.3	0.1
Calcite 1	3.8	3.3	3.5	3.5	0.3
Albite (high)	3.8	3.6	3.4	3.6	0.2
Illite / Mica	6.3	6.3	7.4	6.7	0.6
Pyrite	0.2	0.2	0.2	0.2	0.0



Figure 2-14. The silo bentonite as it looks in 2014. Picture is taken through a hole in the temporary lid.

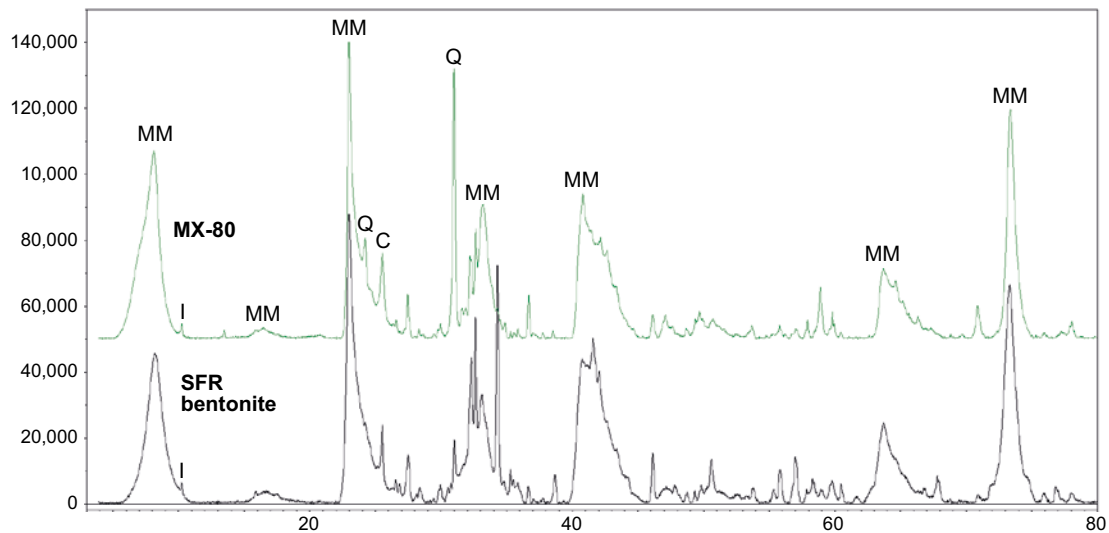

Figure 2-15. XRD for SFR bentonite compared to MX-80 Wyoming bentonite (MM = montmorillonite, I = illite/mica, Q = quartz, C = cristobalite).

Conditioned intermediate-level waste is deposited in the silo in concrete and steel moulds as well as in steel drums (on a drum tray or in a steel box), see Figure 2-16. Grouting of waste packages in the shafts is done progressively. During operations, each shaft is provided with a radiation-shielding lid that is removed at closure.



Figure 2-16. Illustration of the silo during the operating phase.

Closure

The closure plan for SFR (SKBdoc 1358612) describes the planned measures for closure of the silo. In an initial step, the shafts are overcast with cement grout up to the top rim of the concrete silo. This provides a radiation shield on top of the concrete silo, which simplifies the work of reinforcing and casting a concrete lid. The concrete lid is cast on a thin layer of sand and provided with gas venting in the form of pipes filled with sand that penetrate the lid, see Figure 2-17.

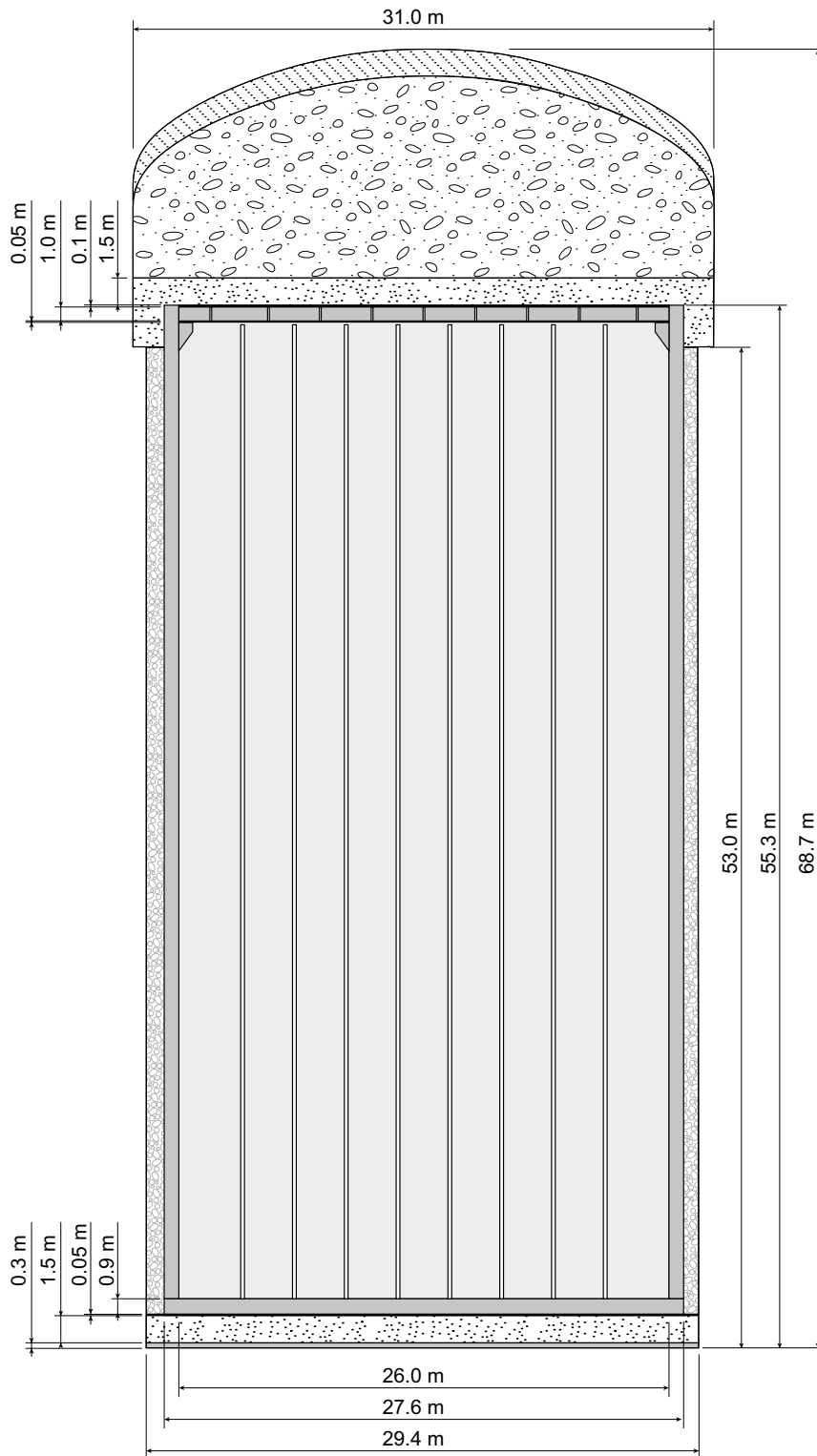

Figure 2-17. Schematic cross-section of the silo after closure.

The top bentonite layer in the gap between rock and concrete silo may have been affected during the operating phase and is replaced with new bentonite. The silo top above the concrete lid is backfilled with different layers of backfill material. The backfill materials intended to be used in the silo top are shown in Figure 2-18. A mixture of sand and bentonite is placed on top of a thin layer of sand and protected by a thin unreinforced concrete slab. The space above it is filled with friction material e.g. crushed rock or macadam and, at the very top, with cement-stabilised sand.

Finally, a plug is installed at the bottom of the silo and two at the top to seal the silo (Section 2.9).

2.6 1BLA, vault for low-level waste

Waste in ISO containers is deposited in the vault for low-level waste. The vault is about 15 m wide, 13 m high and 160 m long. The containers are handled by forklift and stacked two abreast and three to six in height, depending on their size, see Figure 2-19. The vault has a concrete floor cast on a draining foundation, and the rock walls and roof are lined with shotcrete.

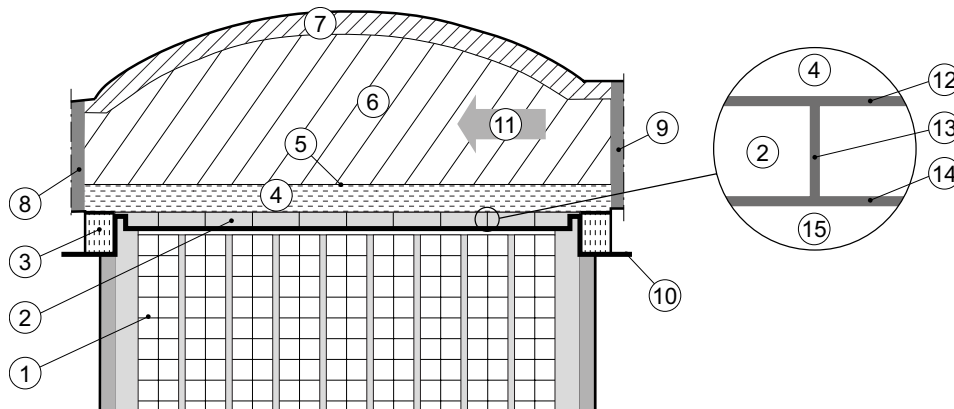

Figure 2-18. Schematic cross-section of silo top after closure. Key to numbering: 1) Waste 2) Reinforced concrete slab with sand layer and gas evacuation pipes 3) Compacted fill of 30/70 bentonite/sand mixture 4) Compacted fill of 10/90 bentonite/sand mixture 5) Unreinforced concrete slab 6) Compacted fill of friction material 7) Cement-stabilised sand 8) Constraining wall of concrete against silo roof tunnel (ISTT) 9) Constraining wall of concrete against loading-in building (IB) 10) Boundary between works belonging to grouting and backfilling 11) Working direction for backfilling with material according to points (6) and (7) 12) Sand layer 100 mm 13) Gas evacuation pipe \varnothing 0.1 m 14) Sand layer 50 mm 15) Grout (permeable).



Figure 2-19. Vault for low-level waste, 1BLA, in SFR 1 during the operating phase.

Closure

The closure plan for SFR (SKBdoc 1358612) describes the planned measures for closure of 1BLA. A concrete wall is installed at the end towards the transverse tunnel (1TT) and approximately 4 m is backfilled with macadam, after which a concrete plug is cast. A mechanical constraint consisting of backfill material is needed at the end towards the waste vault tunnel (1BST), see Figure 2-2, to hold the transition material in the earth dam plug in place. The constraint is made by backfilling 10 m of the waste vault with macadam against a retaining wall and filling the space above the backfill and above the level of the connecting tunnel with concrete. The space around and above the containers will not be backfilled, as backfilling is used to protect concrete structures from block fallout. Also backfilling may damage the ISO containers. Figure 2-20 and Figure 2-21 show schematic illustrations of 1BLA after closure.

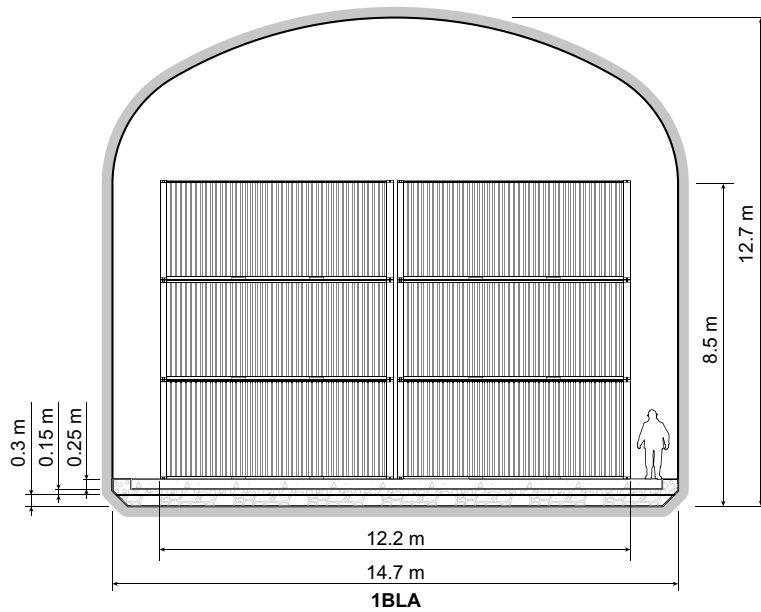

Figure 2-20. Schematic cross-section of 1BLA after closure.

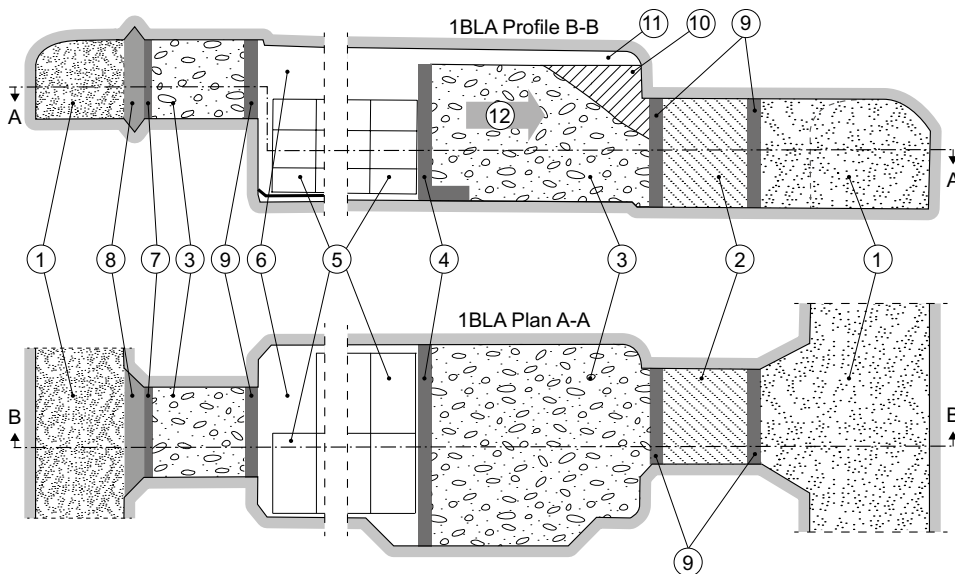

Figure 2-21. Schematic profile and plan of 1BLA after closure. Key to numbering: 1) Bentonite 2) Transition material 3) Macadam 4) Retaining wall 5) Waste 6) Open waste vault 7) Constraining wall and concrete form 8) Mechanical plug of concrete 9) Constraining wall 10) Concrete 11) Gap at roof 12) Working direction for backfilling of waste vault.

2.7 2-5BLA, vaults for low-level waste

Four vaults for low-level waste will be built in SFR 3. The vaults are approximately 18 m wide, 14 m high and 275 m long. The waste will be deposited in ISO containers and stacked (assuming 20-foot half-height containers) two abreast and six in height inside the longitudinal walls. The primary function of the walls is to ensure the stability of the containers and permit access above the containers, see Figure 2-22. The vault has a concrete floor on top of a draining foundation, and the rock walls and roof are to be lined with shotcrete.

Closure

The planned measures at closure of the 2-5BLA vaults are described in the closure plan for SFR (SKBdoc 1358612). Concrete plugs are to be installed at the ends towards the waste vault tunnel (2BST) and the transverse tunnel (2TT) along with mechanical constraints intended to serve as support when the concrete plugs are no longer intact. The constraint is made by backfilling 10 m of the waste vault with macadam against a retaining wall and filling the space above the backfill and above the level of the connecting tunnel with concrete. At closure, the spaces outside the concrete walls and around the containers in the vaults are not backfilled. Figure 2-23 and Figure 2-24 show schematic illustrations of 2-5BLA after closure.

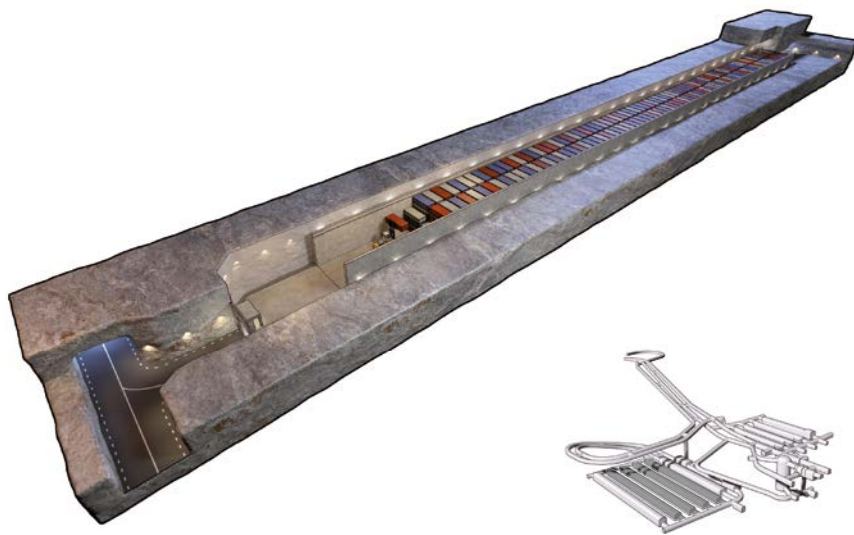

Figure 2-22. Vault for low-level waste, 2-5BLA, in SFR 3 during the operating phase.

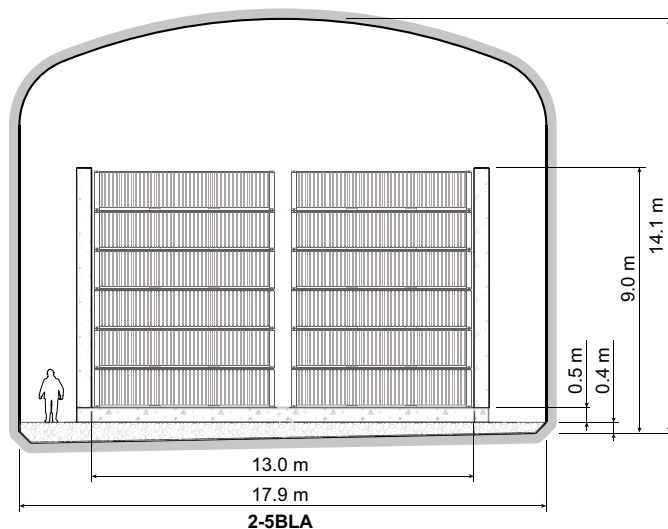

Figure 2-23. Schematic cross-section of 2-5BLA after closure. Note that the figure shows Layout 2.0; Layout 1.5 is used in SR-PSU modelling. The difference is that the concrete walls are 0.5 m higher in Layout 1.5.

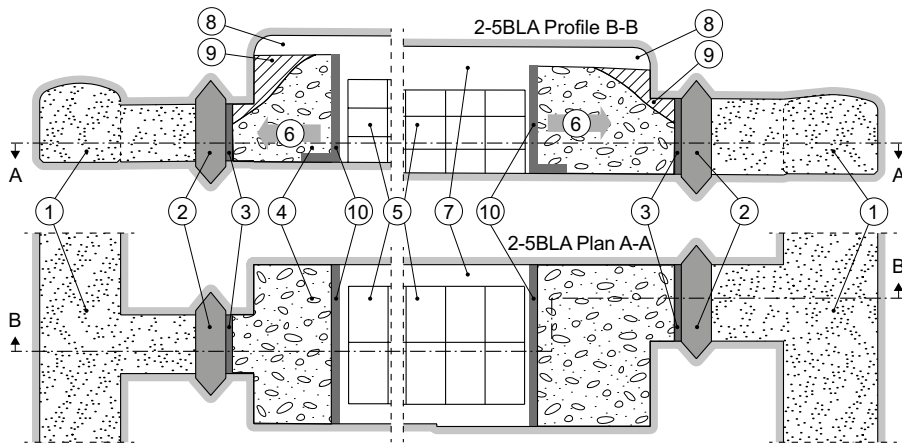

Figure 2-24. Schematic profile and plan of 2-5BLA after closure. Key to numbering: 1) Bentonite 2) Mechanical plug of concrete 3) Constraining wall and concrete form 4) Macadam 5) Waste 6) Working direction 7) Open vault 8) Gap at roof 9) Concrete 10) Retaining wall.

2.8 BRT, vault for reactor pressure vessels

A vault for whole reactor pressure vessels (RPVs) from boiling water reactors (BWRs) will be built in SFR 3. A total of nine RPVs are to be placed end-to-end in BRT. The vault is about 15 m wide, 13 m high and 240 m long (210 m in Layout 1.5). The walls and roof of the vault are to be lined with shotcrete, and concrete cradles are to be installed on the concrete floor to hold the RPVs, see Figure 2-25.

Closure

The planned measures at closure of BRT are described in the closure plan for SFR (SKBdoc 1358612). At closure of the vault, the RPVs will be embedded in grout to ensure a low corrosion rate. In addition, each individual RPV will be filled with concrete or cementitious grout to both reduce the corrosion rate and minimise the risk of collapse, floating-up during embedment grouting and release of any loose contamination remaining after decontamination.

The space around the embedded RPVs is to be backfilled with macadam and concrete plugs are to be installed at the ends towards the waste vault tunnel (2BST) and the transverse tunnel (2TT), see Figure 2-2. Figure 2-26 and Figure 2-27 show schematic illustrations of BRT after closure.

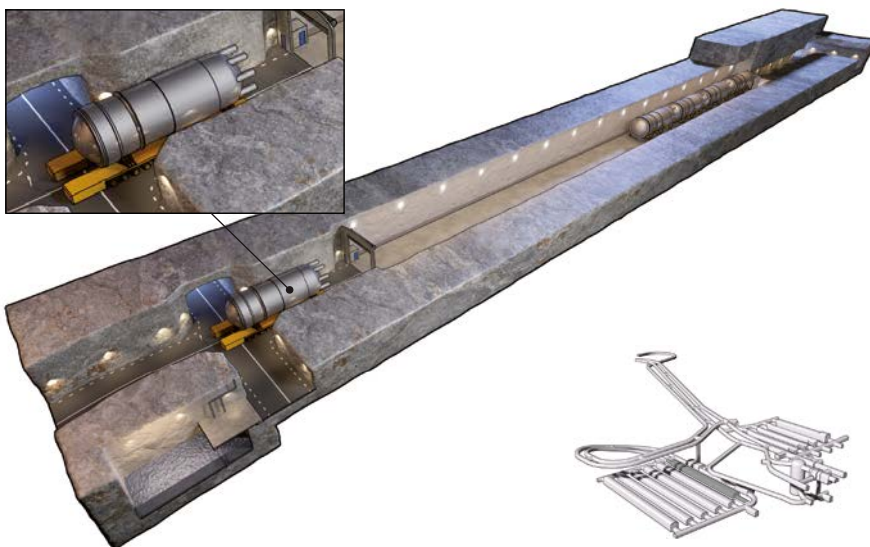

Figure 2-25. Vault for reactor pressure vessels, BRT, in SFR 3 during the operating phase.

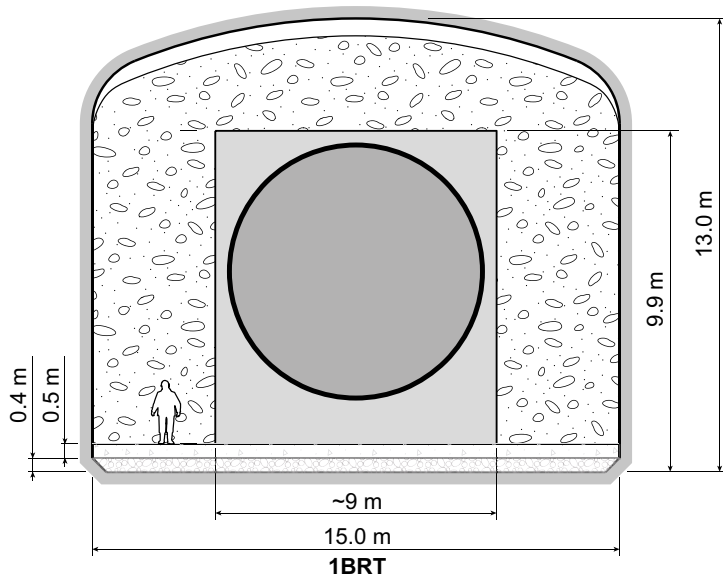

Figure 2-26. Schematic cross-section of BRT after closure. Note that the figure shows Layout 2.0; Layout 1.5 is used in SR-PSU modelling. The difference is that the height is 12.9 m in Layout 1.5.

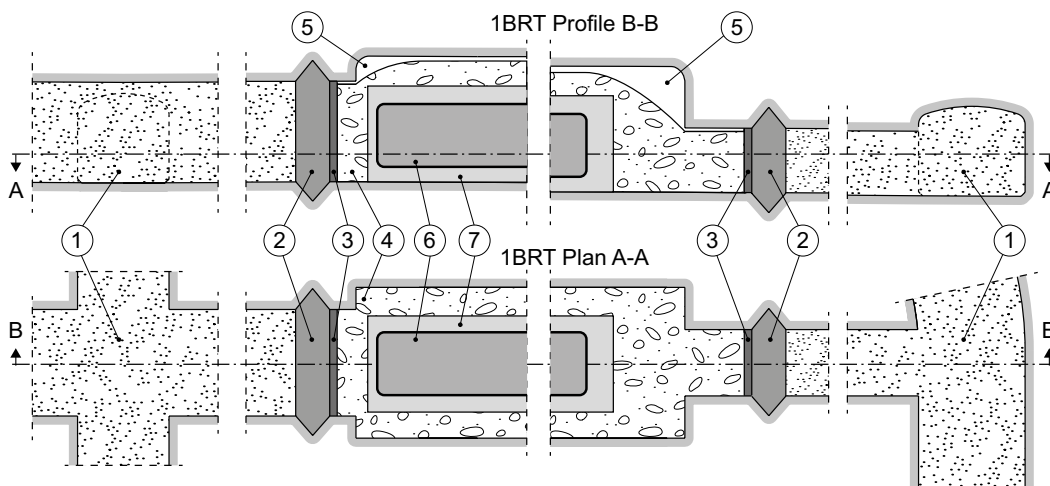

Figure 2-27. Schematic profile and plan of BRT after closure. Key to numbering: 1) Bentonite 2) Mechanical plug of concrete 3) Constraining wall and concrete form 4) Macadam 5) Gap between top surface of macadam and tunnel roof 6) Grout-filled RPVs 7) Embedment grouting.

2.9 Plugs and other closure components

The closure plan for SFR (SKBdoc 1358612) describes the planned measures for closure of SFR. An overall picture of the closed repository is shown in Figure 2-2. Plugs to waste vaults plus closure of tunnels, tunnel system and boreholes are described in the following.

Plugs to waste vaults

A total of five plug sections (P1TT, P1BTF, P1BST, P2TT and P2BST) are to be installed to seal the waste vaults in SFR 1 and SFR 3, see Figure 2-28. All plugs consist of a hydraulically tight section and mechanical constraints that hold it in place. In all plugs except the plug section for the waste vault tunnel in SFR 1 (P1BST), the mechanical constraints are made of concrete (concrete plug). Since the geometry of the tunnels make it unsuitable to install mechanical plugs of concrete to isolate the tight section in P1BST, mechanical plugs of constraining macadam and transition material are used instead.

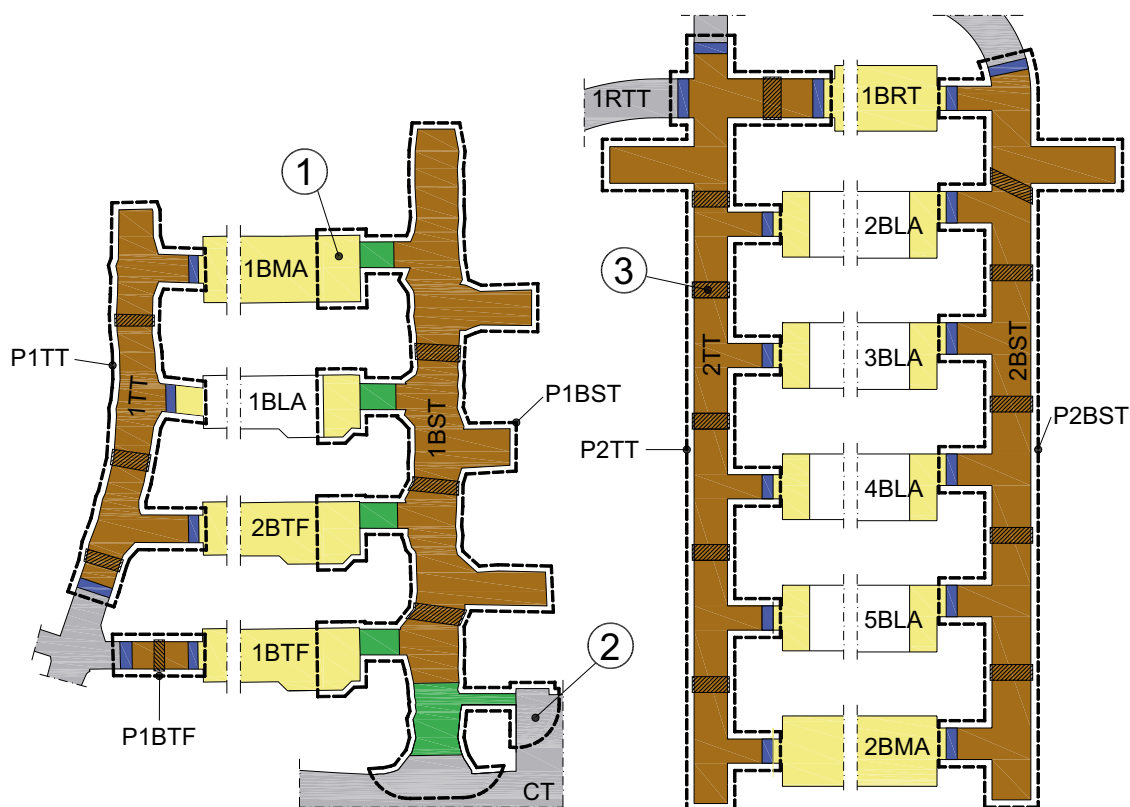

Figure 2-28. Plugs adjacent to waste vaults are marked with a dashed line. Key to numbering:
 1) Yellow colour within borderline for plug sections shows parts of backfill in rock that are active parts of the earth dam plug, green colour shows transition material and brown colour shows hydraulically tight material 2) Grey colour within borderline for plug shows parts of backfill in tunnel system that are active parts of the earth dam plug 3) Hatched areas indicate where damaged zone should be removed by controlled methods.

Plugs to silo

Three plug sections: lower silo plug (NSP), upper silo plug (ÖSP) and silo roof plug (STP) are installed to seal the silo, see Figure 2-29. An important factor in designing the plugs has been to find suitable tunnel geometries to install the mechanical constraints that hold the hydraulically tight sections with bentonite in place.

Sealing of access tunnels and tunnel system

Plugs of concrete and bentonite, see Figure 2-2, will be installed in the access tunnels to minimise the water flow along these tunnels. The design of the plugs is shown in Figure 2-30. The tight section of bentonite is 10 m long. The remaining part of the access tunnels and tunnel system will be backfilled with macadam. The motive for choosing macadam is that it should constitute mechanical support for the plugs and impede human intrusion into the repository.

Sealing of boreholes

The boreholes that were included in the preliminary investigations and those that intersect or are located very close to the underground facility have been or will be sealed prior to the start of construction of SFR 3, and the remaining boreholes will be sealed after operation is concluded. Where the rock has low hydraulic conductivity, the borehole seal must also have low hydraulic conductivity. In the case of positions along boreholes where the rock has high hydraulic conductivity (fractures and deformation zones), requirements are only defined for mechanical stability. Highly compacted bentonite is used where tight seals are needed and cement-stabilised plugs are cast where the boreholes pass through fracture zones.

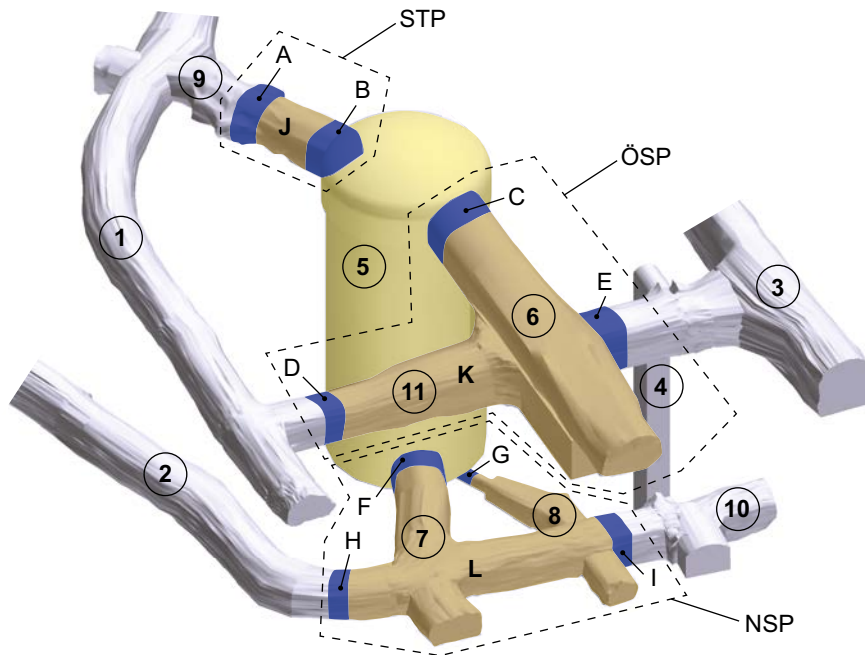

Figure 2-29. Illustration of closed silo with three plug sections (NSP, ÖSP and STP). Blue colour shows concrete plugs (A,B,...I) and brown colour shows hydraulic tight sections (J, K, L). Key to numbering: 1) Construction tunnel, BT 2) Lower construction tunnel, NBT 3) Central tunnel, CT 4) Connecting shaft 5) Silo 6) Loading-in building, IB 7) Silo bottom tunnel, 8) Drainage tunnel 9) Silo roof tunnel, 1STT 10) Terminal part of lower construction tunnel 11) Silo tunnel. Tunnel parts 1, 2, 3, 4 and 10 belong to the tunnel system.

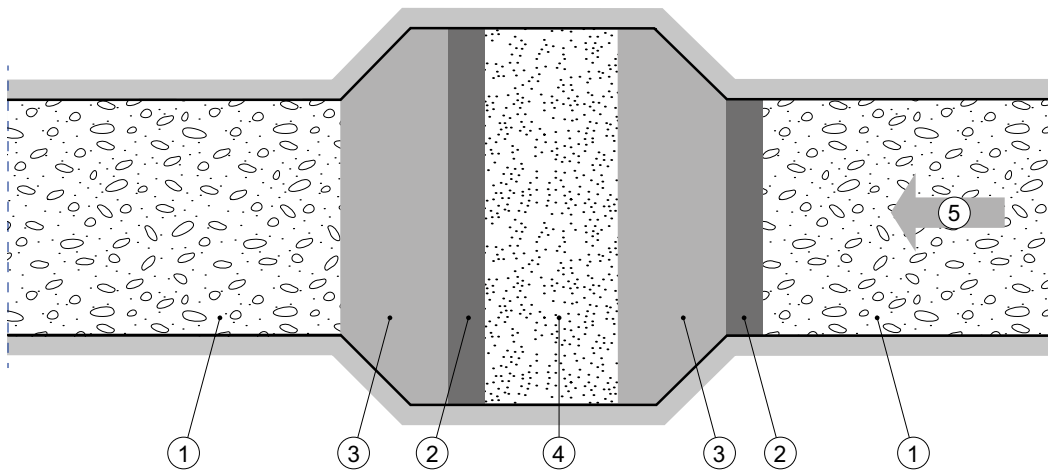

Figure 2-30. Schematic reference design of plug in access tunnels. Key to numbering: 1) Backfill of macadam 2) Constraining wall 3) Concrete 4) Bentonite 5) Working direction.

3 Safety functions

3.1 Introduction

A central element in the methodology of the SR-PSU assessment is the definition of a set of safety functions that the repository system should ideally fulfil over a given timespan. The methodology is an adaption of the one that was introduced in the safety assessment of the KBS-3 repository for spent nuclear fuel, SR-Can (SKB 2006) and developed further in the SR-Site assessment (SKB 2011), where a more detailed description than the previous one is provided.

In contrast to a KBS-3 repository for spent nuclear fuel, where total isolation of the waste is the most important overall safety principle, safety in SFR 1 is based on the limited quantity of activity in the waste and retardation of releases of radionuclides by the engineered barriers and the geosphere. Retardation changes gradually so that it is difficult or impossible to define what acceptable performance is. Therefore, no criteria for safety performance indicators have been defined for SFR in this assessment. The main purpose of the safety performance indicators is to guide the definition of scenarios.

The safety functions of SFR 1, in contrast to those of KBS-3, are not general for the entire repository. The different repository parts have different safety functions. The low flow in the geosphere and the repository's location relative to the shoreline are the same for all parts.

The different safety functions in the different repository parts are:

1. BLA: Limited waste activity.
2. BRT: Limited waste quantity and controlled release of radionuclides through low corrosion rate.
3. BTF repositories: Limited waste quantity and hydraulic and chemical barrier function of concrete tanks.
4. BMA: Limited waste quantity and hydraulic and chemical barrier function of concrete structures.
5. Silo: Limited waste quantity, hydraulic barrier function of silo wall of bentonite and chemical barrier function of concrete structures.

The engineered barriers or other components that have a safety function are illustrated in Figure 3-1. The waste in BLA has the safety function "limited waste quantity"; in the BTF repositories, there is a limited waste quantity and hydraulic and chemical function of concrete tanks. In BMA, there is a limited waste quantity and hydraulic and chemical function of concrete structures. In the silo there is a limited waste quantity, hydraulic function of the silo wall of bentonite and chemical function of concrete structures. The geosphere and the position of the shoreline are also associated with safety functions (SKB 2008b).

For the purpose of this report, only the safety functions for the engineered barriers are of interest. The different engineered barriers in the repository prevent the release of radionuclides.

3.2 Engineered barriers – hydraulic barrier function

The primary purpose of the hydraulic barriers in SFR is to limit the advective transport through the components containing waste. This is achieved by a low hydraulic conductivity of the barrier materials.

3.2.1 BLA

No safety functions have been assigned to the engineered barriers in BLA.

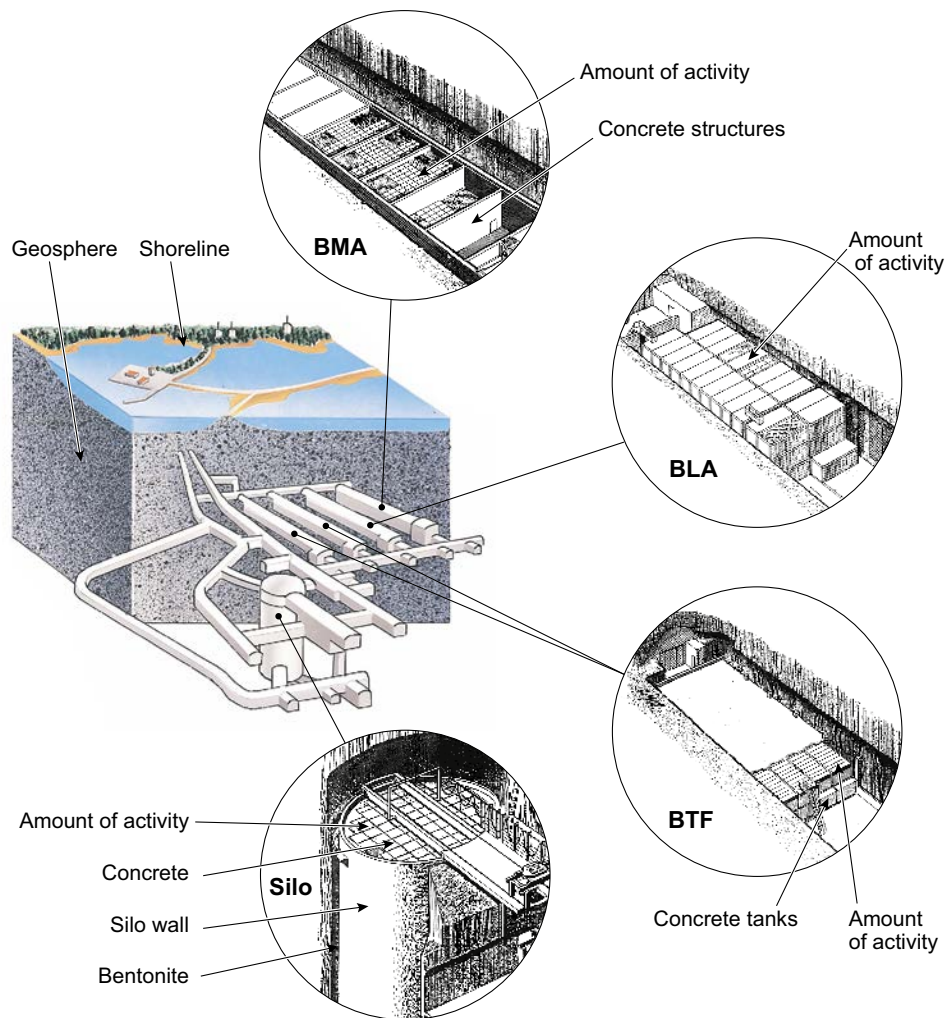

Figure 3-1. Illustration of the engineered barriers or other components that have a safety function in SFR 1.

3.2.2 BRT

The primary barrier in BRT is the slow corrosion of the waste form itself (**Waste process report**). To ensure a low corrosion rate, a high pH is desired. This is ensured by the concrete cover that surrounds the waste. No hydraulic performance is required from the concrete regarding the release of radionuclides. The hydraulic conductivity should however be sufficiently low to protect the cement component in the concrete itself from leaching for a reasonable timescale. This safety function is discussed in Section 9.4.5.

3.2.3 BTF

Concrete tanks with dewatered ion exchange resins, steel drums with ashes and moulds with cement-stabilised ion exchange resins are placed in BTF. Concrete tanks are set up so that they form rooms with ash drums. The containers are grouted with permeable grout. The concrete walls in the tanks, together with the grout, constitute the engineered barrier here and the low hydraulic conductivity in the walls of the concrete tanks constitutes the safety performance indicator. This safety function is discussed in Sections 6.2.2 and 6.4.1.

3.2.4 BMA

In BMA the radioactive waste is stored in concrete compartments that are covered with prefabricated concrete planks and filled with concrete. The engineered barriers are the waste package – consisting of waste, drums and moulds – and concrete walls. All these parts restrict the transport of water through

the waste. In this analysis, however, only one safety function is defined for the concrete compartment walls. The low hydraulic conductivity in the concrete is the safety performance indicator. This safety function is discussed in Sections 5.2.2 and 5.4.1.

In intact concrete, the hydraulic conductivity is so low that diffusion is the dominant transport mechanism. But concrete is not a self-healing material in the same way as bentonite, and there will most certainly be cracks in the concrete walls, which could dominate the mass transport. It should be noted that cracks present before closure will be repaired. However, even a somewhat fractured concrete may have a very low hydraulic conductivity.

3.2.5 Silo

All of the waste in the silo is solidified in concrete or bitumen. The waste is surrounded by the following engineered barriers:

- Waste package.
- Gas permeable grout and compartment walls.
- Concrete silo walls.
- Bentonite or sand/bentonite buffer.

In the silo, a hydraulic safety function is attributed to the bentonite buffer. The hydraulic conductivity of the bentonite comprises a safety performance indicator, Sections 7.2.2, 7.4.1 and 7.4.2. The concrete walls could assigned a safety functions in the same way as the walls in BMA, see above, but since the main hydraulic barrier comes from the bentonite, therefore no safety function is assigned to the concrete (although).

In order that the silo will retain its physical integrity and the water will not be expelled due to gas pressure, gas generated by corrosion and degradation of the waste must be able to escape without causing any appreciable pressure build-up. If the gas pressure exceeds 50 kPa, there is a risk that the silo will not perform as intended. Gas pressure is therefore also a safety performance indicator for limited advective transport in the silo, Section 7.2.3.

3.2.6 Plugs and other closure components

The plugs are actual barriers in the SFR repository. They should meet the following requirements:

1. The plugs shall limit the flow through the caverns and the silo. The design and location of the plugs shall result in a resistance of $> 2 \cdot 10^9$ s. If there is a hydraulically disturbed zone surrounding the tunnels the plugs shall be designed to cut of this. The plugs shall be placed so that they are not short-circuited by water bearing fractures.
2. The plugs shall uphold their function for at least 10,000 years. It is an advantage if they can uphold their function until the end of next glacial cycle, i.e about 70,000 years.
3. Material in plugs and other closure material shall not have negative effect on the repository function to restrain radionuclides by sorption.
4. The hydraulic conductivity of the material used for backfilling tunnels and caverns shall be 10^{-5} m/s or higher.
5. The backfill in tunnels and caverns shall not contain material that has a significant influence on the barriers by influencing the flow resistance in fractures in the rock.
6. The backfill material in tunnels and caverns shall contribute to the long term performance of the plugs by providing mechanical support.

No unambiguous safety function for the plugs has been defined at this stage. However, it is assumed that the plugs will perform well and not form preferential flow paths.

3.3 Temperature

The temperature is an external parameter that may have an impact on the performance on the barriers in SFR. Freezing of concrete and bentonite may have an impact on the hydraulic properties of the materials. The temperature is therefore defined as a safety function indicator, see Sections 5.1.2, 6.1.2 and 7.1.2.

3.4 Engineered barriers – chemical barrier function

Retardation through sorption of radionuclides is one of the most important safety functions in SFR 1. Sorption takes place primarily inside the different repository parts, and is not due solely to the design of the repository but also to the properties of the waste and the chemical composition of the groundwater. A prerequisite for good sorption is a favourable chemical environment.

Sorption of radionuclides will occur in all repository parts and in the surrounding rock. But the greatest potential for sorption exists in the repository parts that contain cement. The safety function “good sorption” is therefore defined as sorption on cementitious material, which includes concrete walls, grout and waste packages. Many radionuclides sorb very strongly in bentonite, rock and in the aggregates in the concrete. Credit is taken for this in the nuclide transport calculations, but it has not been defined as a safety function in this assessment because sorption on cement is assumed to dominate over sorption on other materials.

High pH

In general the sorption of cations increases with pH while the opposite is true for anions. On the other hand, the sorption capacity of cementitious materials reaches a maximum at pH values around 11 and decreases at higher alkalinities. In addition, the increased stability of carbonate and organic ligand aqueous complexes at higher pH's competes with sorption. The chemical environment in the pores in the cement matrix, high pH and high calcium concentrations, necessarily means that the carbonate concentration is low, since it is regulated by calcite equilibrium. Carbonate is otherwise a strong complexing agent and could prevent sorption of numerous radionuclides. Due to its unique chemical properties, the cement matrix in the concrete has proved to be excellent for reducing the concentration of ligands that can prevent the sorption of numerous radionuclides. As long as the cement matrix is not severely degraded, the pH in the pores will be higher than about 10.5, and high pH is therefore an indication that the sorption properties in SFR are favourable. This safety function is discussed in Sections 5.4.6, 6.4.5 and 7.4.6.

Reducing conditions

Some of the radionuclides are redox-sensitive, and for some sorption is much weaker under oxidising conditions. A low redox potential in the engineered barriers is expected to be maintained by the presence of metallic iron and organic material. Sorption of uranium, plutonium and neptunium would decrease considerably under oxidising conditions. This is discussed in Sections 5.4.7, 5.4.9, 6.4.6, 6.4.8, 7.4.8, 7.4.15, 8.4.5, 9.4.6 and 9.4.8.

Low concentrations of complexing agents

Organic compounds from degradation of the waste form (particularly cellulose) could form complexes with the radionuclides and in this way compete with sorption on solid surfaces. It is important to keep the quantity of complexing agents at low levels. This safety function concerns only the waste form. Insignificant amounts of complexing agents are expected to be generated in the barriers.

Available sorption surface

Sorption always takes place on the surfaces of solid phases. Cement has a relatively large porosity, and several of the solid phases of which cement consists are amorphous and have a large specific surface area, which favours sorption. With time, most of the solid phases in cement are slowly transformed into more crystalline substances, and a decrease in sorption capacity can be expected. Degradation of cement that results in precipitations that reduce porosity can also contribute to a reduction in sorption capacity. This safety function is discussed in Sections 5.4.6, 6.4.5 and 7.4.6.

4 Processes and system variables

4.1 Structure for process description

All identified processes are described according to the following template:

Overview/general description

Under this heading, a general description of the knowledge regarding the process is given.

Dependencies between process and system component variables

For each system component a set of physical variables that defines the state of the system is specified. For each process, a table is present under this heading with documentation of how the process is influenced by the specified set of physical variables and how the process influences the variables. In addition, the handling of each influence in SR-PSU is indicated in the table and more thoroughly discussed in the text associated with the table. Table 4-1 shows an example of the handling table.

Boundary conditions

The boundary conditions for each process are discussed. These refer to the boundaries of the relevant system components. The processes for which boundary conditions need to be described are, in general, related to transport of material or energy across the boundaries. For example for chemical processes occurring within the concrete barriers, the discussion of boundary conditions will relate to the boundary conditions of the relevant transport processes occurring in the concrete barriers, i.e. advection and diffusion.

Model studies/experimental studies

Model and experimental studies of the process are summarised. This documentation is the major source of information for many of the processes.

Natural analogues/observations in nature

If relevant, natural analogues and/or observations in nature regarding the process are documented under this heading.

Time perspective

The timescale or timescales on which the process occurs is documented, if such timescales can be defined.

Table 4-1. Dependencies between the Process XX and system component variables.

Variable	Variable influence on process		Process influence on variable	
	Influence present? Yes/No	Description Handling of influence How/If not – Why	Influence present? Yes/No	Description Handling of influence How/If not – Why
Geometry				
Temperature				
Hydrological variables				
Mechanical stresses				
Material composition				
Water composition				
Gas variables				

Influence by the Process XX.
Influence on the Process XX.

Handling in the safety assessment SR-PSU

Under this heading, the handling in the safety assessment SR-PSU is described. Typically, the process is either:

- Defined as irrelevant on the basis of the information under the previous headings.
- Defined as irrelevant provided that a certain condition is fulfilled.
- Included by means of modelling.

The following aspects need to be covered, although no prescribed format for the documentation is given:

Time periods: Over what time period is the process relevant for the system evolution? For example relevant time periods might be:

- The resaturation phase extending from the time of closure until the point in time when the system component is fully water saturated.
- The first 1,000 year after closure.
- The period from 1,000 to 10,000 years after closure.
- The long-term period, extending throughout the 100,000 year assessment period and including the varying conditions in the bedrock caused by long-term climate changes and other processes acting on the surface.

It is important to identify if a process might induce such damage to the barrier system that it can be regarded as a loss of barrier function.

By documenting the relevance of the process for applicable time periods, the process system can be simplified by omitting the process in time periods during which it is not relevant.

Boundary conditions: How are the boundary conditions handled? For example, are spatially and temporally varying chemical and hydraulic conditions considered?

Influences and couplings to other processes: The handling of the documented influences will be discussed, as will couplings to other processes within the system component.

As a result of the information under this subheading, a mapping of all processes to method of treatment and, in relevant cases, applicable models will be produced, see the **Main report** for an example. The mapping will be characterised on different timescales.

Handling of uncertainties in SR-PSU

Given the adopted handling in the safety assessment SR-PSU as described above, the handling of different types of uncertainties associated with the process is summarised.

Uncertainties in mechanistic understanding: The uncertainty in the general understanding of the process is discussed based on the available documentation and with the aim of answering the question: Are the basic scientific mechanisms governing the process understood to a level necessary for the suggested handling? Alternative models may sometimes be used to illustrate this type of uncertainty.

Model simplification uncertainties: In most cases, the quantitative representation of a process will contain simplifications. These may result in a significant source of uncertainty in the description of the system evolution. Alternative models or alternative approaches to simplification for a particular conceptual model may sometimes be used to illustrate this type of uncertainty.

Input data and data uncertainties: The set of input data necessary to quantify the process for the suggested handling is documented. The further treatment of important input data and input data uncertainties will be described in a separate report, the SR-PSU Data report to which reference will be made if relevant.

Adequacy of references supporting the handling in SR-PSU

The adequacy of references **that support the handling** is judged, not all references. A documented factual and quality review is one argument and published by refereed journals or conferences are another.

References

A list of references used in the process descriptions are presented in the final chapter.

4.2 Introduction to the system variables

4.2.1 Definition of the BMA system and variables

The BMA system consists of two sub-systems:

- Concrete barriers.
- Vaults and backfill.

Concrete barriers

Concrete barriers include concrete structures in different repository parts in terms of bottom, lid and outer as well as inner walls in BMA. It also includes shotcrete and rock bolts in the rock walls in all repository parts. During the work with this report it has been decided that the waste rooms should be back-filled.

Vaults and backfill

Vaults and backfill refer to the voids and backfill outside the concrete structures in BMA.

4.2.2 Definition of the BTF system and variables

The BTF system consists of two sub-systems:

- Concrete barriers.
- Vaults and backfill.

Concrete barriers

The concrete barrier system includes concrete structures in floor and lid in the BTF vaults. It also includes shotcrete and rock bolts in the rock walls in all repository parts. Grout will be filled in the void between the concrete tanks and the vault walls in the BTF vaults and in between the ash drums in 1BTF.

Vaults and backfill

The sand/gravel in the repositories refers to the sand/gravel top filling in BTF. The corresponding processes are described as vault and backfill processes.

4.2.3 Definition of the Silo system and variables

The Silo system consists of three sub-systems:

- Bentonite barrier.
- Concrete barrier.
- Vaults and backfill.

Bentonite barrier

The bentonite barrier system refer to the sand/bentonite in the top and bottom of the Silo and of the bentonite surrounding the cylindrical concrete walls of the Silo.

Concrete barrier

Concrete barriers include concrete structures in different repository parts in terms of bottom, lid and outer as well as inner walls in the Silo. It also includes shotcrete and rock bolts in the rock walls in all repository parts. Concrete barriers also include the grout backfill surrounding the waste packages in the Silo.

Vaults and backfill

Vaults and backfill refer to the voids and backfill in the Silo cupola. It also includes the sand layer above the concrete lid and the gas devices in the Silo.

4.2.4 Definition of the BLA system and variables

The BLA system consists of only one sub-system; the vault and backfill. The variables for the BLA system are given in Table 4-2.

Vaults and backfill

Vaults and backfill refer to the voids (no backfill is foreseen) surrounding the ISO-containers in BLA.

Table 4-2. The definition of variables for all systems.

Variable	Definition
Geometry	Volume and dimensions of the barriers. Porosity and pore characteristics of the barriers.
Temperature	Temperature.
Hydrological variables	Magnitude, direction and distribution of water flow. Degree of saturation. Water pressure. Aggregation state (water and/or ice).
Mechanical stresses	Stress and strain in the barriers.
Material composition	Amount, composition and surface characteristics of the materials in the barriers. Type and amount of chemicals. Type and amount of organic materials and components that can be utilised by microbes as nutrients and energy sources. Type and amount of microbes and bacteria.
Water composition	Composition of water including radionuclides. Redox, pH, ionic strength, concentration of dissolved species, type and amount of colloids and/or particles, amount and composition of dissolved gas. Density and viscosity. Type and amount of microbes, bacteria and other types of biomass.
Gas variables	Amount, composition, including radionuclides. Volume, pressure, degree of saturation. Magnitude, direction and distribution of gas flow.

4.2.5 Definition of the BRT system and variables

The BRT system consists of two sub-systems:

- Grout and concrete fill.
- Vaults and backfill.

Grout and concrete fill

The grout and concrete fill system includes the grout surrounding the reactor pressure vessel (RPV) as well as the concrete fill inside.

Vaults and backfill

The vault in BRT is filled with macadam.

4.2.6 Definition of the system plugs and and other closure components

The system plugs and other repository components consist of four subsystems:

- Bentonite plugs.
- Concrete plugs.
- Earth dams.
- Backfill.

Bentonite plugs

The purpose of the bentonite plugs are to act as hydraulic seals with long-term performance.

Concrete plugs and earth dams

The concrete plugs and earth dams refer to the structures that are supposed to keep the bentonite in position.

Backfill

The term “Backfill” refers to the material that is filled in the tunnels apart from the plugs. The purpose of the backfill is to support the rock and the plugs mechanically.

4.3 Introduction to the processes

Many of the concrete and steel processes are the same as in the **Waste process report**. Therefore, references are made to the corresponding process in that report unless there is a discrepancy between the waste/waste matrix, waste packaging and the technical barrier process. One part that will not, in most cases, be the same between the different reports is the heading handling in the safety assessment. The text under this heading can vary substantially between the barriers and the waste part.

5 1–2BMA

5.1 Thermal processes

5.1.1 Heat transport

Overview/general description

Heat transport, or heat transfer, refer to the processes of energy exchange caused by differences in temperature. Generally, heat transport tends to alter the temperature distribution of a system. The temperature may also be changed due to energy dissipation in e.g. chemical reactions or radioactive decay. However, the generated power in dissipative processes in SFR (cement hydration, metal corrosion, radioactive decay of waste etc) in the long-term is too small to significantly influence the temperature evolution. Thus, for SFR conditions, a description of heat transport is equivalent to a description of the temperature evolution of the repository.

The heat transport mechanisms relevant for SFR are conduction and convection. The process of heat conduction tends to level out temperature differences within a body or between bodies in contact with each other, without associated mass transfer. The heat flow is proportional to the temperature gradient (∇T ; Fourier's law) and the general governing heat equation (derived from Fourier's law and the law of conservation of energy) for the temperature (T) evolution is

$$\frac{\partial T}{\partial t} = \frac{1}{c_p \cdot \rho} \nabla \cdot (\lambda \nabla T) \quad (5-1)$$

where c_p is specific heat, ρ is density, and λ is thermal conductivity. Obviously, a general description of heat conduction is a major task in a system composed of many different materials, with different c_p , ρ and λ values, in a complex geometry.

Apart from conduction, heat will also be transferred during mass transport (convection). A general description of this process is also obviously complex, as it e.g. couples to the process of water transport (Section 5.2.2). Convective heat transfer is expected to become more influential with time as the hydraulic conductivity of the waste packages increases due to degradation processes. Furthermore, heat convection in the the gas phase will be the dominating heat transfer process during the operational phase of the repository, before closure and subsequent water saturation.

The description of temperature evolution will be modified when phase changes occur, i.e. when water in the repository freezes or thaws. During freezing or thawing, temperature does not change although heat transfer occurs (c_p is infinite at the phase transition temperature). Freezing/thawing is treated as a separate process (Section 5.1.2).

Dependencies between process and system component variables

Table 5-1 shows how the process influences, and is influenced by, all system variables.

The temperature evolution of SFR is completely dictated by its boundary conditions as it does not contain any significant heat sources (waste produces negligible amounts of decay heat). Furthermore, this temperature evolution occurs on a very long time scale. Therefore the repository temperature itself is treated as a boundary condition, and the heat transport process is not explicitly taken into account when the various repository compartments are considered. The treatment of the temperature evolution of SFR and its surrounding is found in the **Climate report**.

Boundary conditions

The process itself is treated as a boundary condition – i.e. the repository temperature is given as a function of time. The evaluation of this temperature is treated in the **Climate report**.

Table 5-1. Direct dependencies between the process “Heat transport” and the defined system variables and a short note on the handling in SR-PSU.

Variable	Variable influence on process		Process influence on variable	
	Influence present? Yes/No Description	Handling of influence How/If not – Why	Influence present? Yes/No Description	Handling of influence How/If not – Why
Geometry	Yes, the constitution of the system determine how heat flows.	The process is not explicitly handled. See justification in text.	No.	
Temperature	Yes. Temperature differences is a requirement for the process.	The process is not explicitly handled. See justification in text.	Yes. Heat transport tends to even out temperature differences.	The process is not explicitly handled. See justification in text.
Hydrological variables	Yes. Water flow may transport heat. Heat capacities may change with saturation state and aggregation state.	The process is not explicitly handled. See justification in text.	Yes, through e.g. convection. The influence is however negligible because temperature differences are small.	The process is not explicitly handled. See justification in text.
Mechanical stresses	Yes, in principle as e.g. heat capacities may depend on stress state. The effect is however negligible.	The process is not explicitly handled. See justification in text.	Yes. Due to thermal expansion/contraction.	The process is not explicitly handled. See justification in text.
Material composition	Yes. Different materials have different thermal conductivities, specific heats etc.	The process is not explicitly handled. See justification in text.	No.	
Water composition	Yes in principle as e.g. heat capacities may depend on composition. The effect is however negligible.	The process is not explicitly handled. See justification in text.	No.	
Gas variables	Yes. Gas flow may transport heat.	The process is not explicitly handled. See justification in text.	Yes, but relevant only during the operational phase when the repository is not water saturated.	The process is not explicitly handled. See justification in text.

Model studies/experimental studies

Heat transfer processes have generally been extensively studied and modelled. See the **Climate report**.

Natural analogues/observations in nature

See the **Climate report**.

Time perspective

The process of heat transport is always active.

Handling in the safety assessment SR-PSU

The temperature evolution of SFR is completely determined by its outer boundary conditions as the heat generation in the barriers and waste forms is negligible (see heat generating processes in e.g. Sections 5.4.6 (cement hydration), and 5.4.9 (metal corrosion), and in the **Waste process report**. Furthermore, this temperature evolution occurs on a very long time scale. Therefore, the repository temperature itself is treated as a boundary condition, and the heat transport process is not explicitly taken into account in the radionuclide transport modelling when the individual waste packages and repository compartments are considered. The treatment of the temperature evolution of SFR and its surroundings is found in the **Climate report**.

Handling of uncertainties in SR-PSU

Not handled as the process is not treated explicitly.

5.1.2 Phase changes/freezing

Overview/general description

The SFR repository will experience climate variations during its lifetime, and the possibility of permafrost (ground having a temperature below 0°C for at least two consecutive years) reaching the repository depth must be taken into account. The potential for permafrost in Forsmark in the next 60,000 years is analysed by Brandefelt et al. (2013). Based on climate model simulations and permafrost model simulations, they conclude that bedrock temperatures below 0°C cannot be excluded in this period. These results are taken into account in the Global warming climate case and the Early periglacial climate case (**Climate report**). Freezing of water in all repository components must therefore be analysed. As discussed in the **Climate report**, another possibility is that climate conditions in south-central Sweden remain temperate for the next 100,000 years, as described by the Extended global warming climate case (**Climate report**).

Freezing in SFR will always occur in an approximately vertically directed (weak) temperature gradient and the models indicate that the minimum temperature could be as low as -10°C. Furthermore, the modelled permafrost aggregation rates are typically in the range 5–20 cm/year, which means that a freezing front may take some thousands of years to pass through the repository. In all of the considered climate scenarios, the first period of permafrost at repository depth will occur several thousands of years after closure. The first occurrence of permafrost, after around 15,000 years, is found in one of the base case scenarios, the Early periglacial climate case.

Pure bulk water at atmospheric pressure freezes at 0°C. However, there are several mechanisms which causes freezing or freezing related phenomena at different temperatures

- Freezing point depression due to increased pressure.

The freezing point of water decreases with increasing pressure. This is a consequence of the higher density of liquid water as compared to ice. The freezing point depression, ΔT_f , as a function of the increased pressure ΔP is quantified by the Clapeyron equation (Atkins and de Paula 2006):

$$\Delta T_f = \frac{\Delta v}{\Delta s} \Delta P \approx -0.075^\circ\text{C}/\text{MPa} \cdot \Delta P \quad (5-2)$$

where Δv and Δs are the difference in molar volume and molar entropy between liquid water and ice, respectively (note that Δv is negative, while Δs is positive). Equation (5-2) shows that very high pressures are required to lower the freezing point significantly. For example, the typical hydrostatic pressure in SFR (50–100 m water column) lowers the freezing point by only the order of tenths of degrees.

- Freezing point depression due to presence of solutes.

The presence of solutes in water lowers the freezing point. This is mainly a colligative property, i.e. the freezing point depression depends merely on the concentration of all solutes. A solute of molal concentration c_m (mol/kg) in water lowers the freezing point as (Atkins and de Paula 2006):

$$\Delta T_f = -1.86^\circ\text{C}/\text{m} \cdot i \cdot c_m \quad (5-3)$$

where i is van't Hoff's factor, which accounts for the dissociation of the dissolved substances (e.g. a NaCl solution of 1 mol/kg will contribute approximately 2 mol/kg because of dissociation into one Cl^- and one Na^+ ion).

Equation (5-3) shows that the freezing point depression due to solutes can be significant, i.e. in a NaCl solution of 1 mol/kg, the freezing point depression is approximately -3.7°C. Furthermore, as freezing occurs, solute particles are generally expelled from the ice phase which may increase the concentration of the remaining liquid. Thus, ice and liquid solution may co-exist in equilibrium at a range of temperatures, and complete solidification may not necessarily occur at one specific temperature.

- Freezing point depression due to small confining volume.

Several components of SFR can be characterised as porous systems. Water in these systems is confined within pores of a certain size distribution.

Generally, the (free) energy of an ice crystal of a certain size and shape has a surface contribution, which acts to lower the freezing point. For a bulk sample this contribution is negligible (although it explains the existence of metastable super cooled liquid water) but becomes increasingly influential for confining pores of decreasing size. The mechanism of lowering the freezing point in this manner is known as the Gibbs–Thomson effect (see e.g. Dash et al. 2006).

For a spherical pore of radius r , the freezing point depression for water is given by (see e.g. Sliwiska-Bartkowiak et al. 1999):

$$\Delta T_f = -\frac{2 \cdot T_{fb} \cdot \Delta\sigma \cdot \bar{v}}{Lr} \approx -\frac{50 \text{ nm} \cdot ^\circ\text{C}}{r} \quad (5-4)$$

Where T_{fb} is the freezing point of bulk water measured in absolute temperature (Kelvin), $\Delta\sigma$ is the difference in surface tension between the liquid–pore wall and ice–pore wall interfaces, L is the latent heat of freezing bulk water, and \bar{v} is the specific volume of bulk water. The approximation in Equation (5-4) is achieved by estimating $\Delta\sigma$ from the corresponding values of liquid–vapour and ice–vapour surface tension. It is seen from this formula that, for pores on the sub micro metre scale, the freezing point depression can be substantial, on the order of tens of degrees.

As the pores are distributed over different size ranges, this implies that freezing of the water does not take place at one specific temperature, but occurs gradually in a temperature interval. Within this temperature interval, liquid water and ice occur simultaneously in the porous system.

- Effects of premelting and temperature gradients (frost heave).

A general feature of solids is that premelting occurs at their bounding surfaces at temperatures close to, but below, the bulk phase melting temperature. Specifically, for ice in soils or other porous systems, small films of mobile water occur at e.g. the grain/ice interfaces (Dash et al. 2006). The properties of these films depends strongly on temperature, in particular the film width and pressure increases with temperature. This has the consequence that liquid water has a driving force to be transported from warmer to colder parts in a temperature gradient in a partially frozen porous system.

This is the basic mechanism for the formation of ice lenses in certain soils – where water is transported from lower (unfrozen) to higher parts of the ground where it freezes and build up a section of pure ice. This lens build-up may lead to increased stress and displacement of the soil above the lens. The latter phenomenon is known as frost heave (Andersland and Ladanyi 2004).

Ice lens formation is promoted in soils with small particles (silts and clays) due to their large specific surface area. In clay-rich soils however, the effect is suppressed due to very low hydraulic conductivity. Soils in which ice lens build-up is promoted are said to be frost susceptible.

An additional effect of ice lens formation on a soil is that repeated cycles of freezing and thawing may cause particle sorting which changes the hydraulic properties (see e.g. Chamberlain and Gow 1979).

Consequences of freezing for BMA barriers

As water expands when it freezes, damaging stresses and pressures will be induced if water cannot be expelled from the region where freezing occurs, or if the water transport capacity is too limited.

Freezing of SFR will always occur in an approximately vertical thermal gradient, with temperature increasing with depth. Under many circumstances, therefore, freezing will not cause increased pressures as water can be expelled downwards. However, because freezing point depression will be different in different components of the repository, situations will also occur where “trapped” water will freeze and induce damaging pressure and stresses.

Further, damaging pressure and stresses might be induced by ice lens formation in frost susceptible component materials. This mechanism is active only when unfrozen water can be transported from below the repository.

Furthermore, the hydraulic conductivity may be increased in certain repository components as a consequence of repeated freezing/thawing due to changes in soil structure (particle sorting).

Foremost, the effects of freezing on the repository are seen to be secondary in the sense that other possibly damaging processes are induced. In particular may the safety function of BMA (Section 3.2.4) reduce, as the hydraulic conductivity may increase in its components after freezing. The freezing processes are coupled to the following other processes:

- Heat transport (energy is released to the surroundings during freezing, and taken from the surroundings during thawing, Section 5.1.1).
- Mechanical processes (due to increased pressures and stresses, Section 5.3).
- Water transport under saturated conditions (due to increased hydrostatic pressure, Section 5.2.2).
- Advection and dispersion (due to increased hydrostatic pressure, Section 5.4.1).
- Transport of radionuclides in water phase (due to increased hydrostatic pressure and due to cut-off transport paths when frozen, Section 5.5.2).

Dependencies between process and system component variables

Table 5-2 shows how the process influences, and is influenced by, all system variables. In addition, the handling of each influence in SR-PSU is indicated in the table and more thoroughly discussed in the text below.

Table 5-2. Direct dependencies between the process “Phase changes/freezing” and the defined system variables and a short note on the handling in SR-PSU.

Variable	Variable influence on process		Process influence on variable	
	Influence present? Yes/No	Handling of influence How/If not – Why	Influence present? Yes/No	Handling of influence How/If not – Why
Geometry	Yes. Freezing point is influenced by confinement geometry if it is small (sub microns). Frost susceptibility depends on pore geometry.	Freezing points (or temperature intervals) are estimated for each component material.	Yes. Pore geometries may be different after freezing. Fractures may have been created or widened. Cycles of freezing/thawing may cause particle sorting.	Altered hydraulic conductivity after permafrost period.
Temperature	Yes. Freezing occur at a certain temperature or in a certain temperature interval.	Freezing points (or temperature intervals) are estimated.	Yes. Freezing releases energy. Thawing consumes energy.	Neglected as the influence of the repository on temperature evaluation is minor. See also Section 5.1.1.
Hydrological variables	Yes. Water pressure has a minor influence on freezing point.	Insignificant, unless very high pressures.	Yes. Freezing may cause pressure increase and affect water flow. Freezing may also reduce conductivity (a completely frozen system does not flow).	The barrier function of concrete is considered lost after a freezing/thawing cycle.
Mechanical stresses	Yes. Pressure influences freezing point.	Insignificant, unless very high pressures involved.	Yes. Freezing and frost heave may induce stresses and strains.	Altered hydraulic conductivity after permafrost period. Effect on host rock is estimated.
Material composition	Yes. Freezing point is influenced by surface properties.	Freezing points (or temperature intervals) are estimated.	No.	
Water composition	Yes. Freezing point is influenced by type and concentration of solutes.	Estimated from water chemistry.	Yes. Freezing may change composition of remaining unfrozen water.	Neglected, because possible freezing is slow in comparison to diffusive and advective mass transfer.
Gas variables	No. Indirectly through dissolved gases. Insignificant unless gas pressures are high. Handled via water composition.		No.	

Boundary conditions

Temperature in the repository set by climate evolution. (Pore) geometries of the components.

Model studies/experimental studies

The field of freezing in porous systems is well studied both from an engineering and geological perspective owing to its technological and environmental importance (see e.g. Dash et al. 2006, Sliwinska-Bartkowiak et al. 1999).

Natural analogues/observations in nature

A lot of research has been performed on freezing phenomena in permafrost regions (see e.g. Kessler and Werner 2003). Although information certainly can be gained from this type of research it may not be directly applicable to the engineered components of the SFR repository.

Time perspective

The freezing process is coupled to periods of permafrost and must be considered during the entire repository lifetime. However, the first period of permafrost is not expected until several thousand years after closure.

Handling in the safety assessment SR-PSU

Concrete: Concrete is a porous system and is expected to be completely water saturated at the time of the first permafrost period (Emborg et al. 2007). Emborg et al. (2007) estimated the limiting amount of water which can be frozen in the concrete without damaging it to 5 L/m³. By considering the pore size distribution of the concrete, they also estimated the amount of water being frozen at –5°C and –10°C to 17 L/m³ and 30 L/m³, respectively. Consequently, cracking is expected to occur in the concrete during the permafrost period to such an extent that its physical barrier functions are lost.

Sand: The major part of the pores in pure sand is large enough for the system not to show any significant freezing point depression effects. Further, also the ice lens formation mechanism is negligible in pure sand. As a result, system components of pure sand will not induce secondary effects when they freeze, and their hydraulic properties will not change due to a freezing/thawing cycle.

Handling of uncertainties in SR-PSU

Uncertainties in mechanistic understanding

The physical mechanisms described here are well described and well studied phenomena.

Model simplification uncertainties

There is an uncertainty in the timing and the extent (in temperature and time) of the permafrost periods, as well as in the exact temperature range of freezing in the concrete.

Input data and data uncertainties

All freezing effects depend directly on the temperature evolution of the repository. The uncertainties in these predictions are discussed in e.g. Brandefelt et al. (2013).

Adequacy of references supporting the handling in SR-PSU

The references are judged to be adequate and sufficient to support the handling in SR-PSU. All supporting references are either peer-reviewed articles or documents which have undergone factual review. Other references have been used for general background information, and not all of these have been peer-reviewed to the same standard.

5.2 Hydraulic processes

5.2.1 Water uptake and transport during unsaturated conditions

Overview/general description

The BMA rock vault will after backfilling and closure be filled with water mainly through water bearing fractures intersecting the vault. Water will at first fill up the highly permeable backfill and then enter into the compartments through fractures in the concrete. Finally the concrete matrix and the waste packages will be slowly water saturated. The time until full saturation of the entire BMA depends on the rock hydrology, the fracture frequency and properties of the concrete structure and the hydraulic conductivity of the waste packages and the concrete matrix. It depends also on the ability of trapped air to diffuse out to the rock. The barriers in BMA: concrete and sand, show rather different hydraulic behaviour. In this section a general description of water transport in porous materials is given.

Water transport in porous materials under unsaturated conditions is a complex process that is dependent on, inter alia, material composition, temperature, degree of water saturation and water content. The most important driving force for water saturation under SFR conditions is a gradient in water pressure or relative humidity in the pores of the material that follows after water inflow from the surrounding rock. The supply of water from the rock by water transport in fractures and in the rock matrix is also a decisive factor for the temporal evolution of the process.

The following is a detailed description of the process. The processes of unsaturated flow are more complicated and less known than those of saturated flow. The degree of detail is appropriate to indicate a general understanding, but is not necessary for the needs of the safety assessment to, for example, model the main features of the hydraulic evolution of the backfill and concrete. The effect of gas production is treated in Section 5.2.3.

The following hydraulic sub-processes can be distinguished for the backfill and matrix flow in the concrete:

- Transport of water in liquid phase, which is controlled and driven by
 - A1) a pressure gradient in the water,
 - A2) a temperature gradient,
 - A3) an osmotic gradient,
 - A4) gravity (coupled to A1),
 - A5) a density gradient (coupled to A1).
- Transport of water in vapour form, where transport is controlled and driven by
 - B1) a pressure gradient in the water,
 - B2) a temperature gradient,
 - B3) an osmotic gradient,
 - B4) gravity,
 - B5) a density gradient.
- Phase transitions between water and vapour by:
 - C1) evaporation,
 - C2) condensation.
- Thermal expansion of
 - D1) water,
 - D2) air.
- Compression of
 - E1) water,
 - E2) air.
- Transport in water of
 - F1) dissolved air.

These processes are coupled, and are in some cases different sides of the same process. They can be described and modelled in different ways. An important variable is the porewater pressure, which can be described according to Equation (5-5).

$$\psi = (u_a - u_w) + \pi \quad (5-5)$$

where ψ is the free energy of the soil water (usually named total suction), u_w is the porewater pressure, u_a is the pore gas pressure and π is the osmotic suction of the external groundwater. ($u_a - u_w$) is called the matric suction.

The total suction can thus be described from a geotechnical viewpoint as the sum of the matric suction, which can be said in simplified terms to stem from capillary effects, and the osmotic suction, which is dependent on differences in ionic concentration.

The main driving force for water flow in unsaturated porous materials is usually considered to be the gradient in porewater pressure, which means that the matric suction and the pore gas pressure are important variables in the modelling of water flow in unsaturated materials. The total suction is a function of the composition of the material (called retention curve).

The total suction can also be expressed in terms of relative humidity of the porous material. Using a thermodynamic approach, total suction is the free energy state of soil water, which can be determined from the partial vapour pressure of water (Fredlund and Rahardjo 1993). Equation (5-6) shows the relation between the partial vapour pressure p and the suction, ψ . The ratio p/p_s corresponds to the relative humidity and Equation (5-6) thus states a strict relation between relative humidity and suction.

$$\psi = -\frac{R \cdot T}{v_{w0} \cdot \omega_v} \ln\left(\frac{p}{p_s}\right) \quad (5-6)$$

where

ψ = Suction (kPa).

T = Absolute temperature (K).

R = Universal gas constant (8.31432 J/(mol K)).

v_{w0} = Specific volume of water ($1/\rho_w$ m³/kg).

ρ_w = Density of water (kg/m³).

ω_v = Molecular mass of water vapour (18 kg/kmol).

p = Partial pressure of porewater vapour (kPa).

p_s = Saturation pressure of water vapour over a flat surface of pure water at the same temperature (kPa).

The understanding of the processes that drive water transport in unsaturated porous materials and the knowledge of how the processes are influenced by different factors are not complete. The following description (A1–A5, B1–B5, C1–C2, D1–D2, E1–E2 and F2) pertains chiefly to the models that are used for soil materials (Fredlund and Rahardjo 1993).

A1. Transport of water in the liquid phase, which is driven by a water pressure gradient, can be described by a refined version of Darcy's Law. The parameters that control the process are the material's hydraulic conductivity K and the difference in porewater pressure u_w . Both of these can be described as functions of the void ratio e , the degree of saturation S_r , the ion concentration in the porewater i_c and the temperature T . The porewater pressure of unsaturated porous materials is generally also a function of the wetting history, i.e. whether the material undergoes wetting or drying, and the total average external stress and (in the saturated state) the hydraulic head.

The primary driving force for the liquid-phase water flow is the porewater pressure gradient. The hydraulic conductivity varies strongly with the degree of saturation.

A2. The influence of a temperature gradient on the transport of water in the liquid phase is small and mainly indirect via change in water retention properties and water density with temperature except for temperatures below 0°C (see Section 5.1.2 about freezing).

A3. Transport of water in the liquid phase, which is driven by an ion concentration gradient, osmosis. Significant osmotic effects can arise at high salinities in the groundwater. The driving force can be visualised as a diffusion process driven by an osmotic gradient.

A4. Transport of water in the liquid phase, which is driven by gravity. The influence of gravity is reflected in the hydraulic head and thus taken care of by process A1.

- A5. Transport of water in the liquid phase, which is driven by a density gradient in the water. Differences in the density of the water can be caused by e.g. differences in temperature or salinity.
- B1. Transport of water in the vapour phase, which is driven by a vapour pressure gradient. The vapour pressure u_v in the fraction of the pores that is air-filled or the relative humidity ($RH = u_v/u_{v0}$ where u_{v0} is the saturation pressure in the air) is in equilibrium with the total suction potential in the liquid phase. If RH is higher than the equilibrium relationship, water vapour condenses and increases the quantity of liquid, which in turn reduces the total suction until equilibrium is re-established. If the total suction differs in different parts of a soil, for example due to different water ratios, this leads to different vapour pressures, and transport of water vapour in the unfilled portion of the pores takes place with the vapour pressure difference as a driving force. At similar temperature and other circumstances, water vapour is thus transported in the gradient of the relative humidity and (due to the direct correlation) in the gradient of total suction. However, this transport is parallel to process A1, which takes place in the liquid phase. The relationship between these transport mechanisms has not been fully clarified.
- B2. Transport of water in the vapour phase, which is driven by a temperature gradient, appears to be the most important process for vapour transport. This process can also be regarded as a part of process B1. A temperature difference brings about a vapour pressure difference which transports vapour from a warmer part to a colder part. It can also be modelled as a diffusion process driven by a temperature difference (Philip and de Vries 1957). However, there are so small temperature gradients in SFR that this process probably can be neglected.
- B3. Transport of water in the vapour phase, which is driven by an osmotic gradient. This is an indirect process since the vapour is driven by a difference in vapour pressure that can be settled by a difference in osmotic pressure.
- B4 and B5.
Transport of water in the vapour phase, which is driven by gravity or a density gradient. These processes are presumably insignificant.
- C1 and C2.
Phase transitions via evaporation and condensation are constantly occurring in a temperature gradient where evaporation in the warmer part is accompanied by condensation in the colder part. The lack of temperature gradient in SFR makes this process insignificant.
- D1 and D2.
Thermal expansion of water in the liquid and vapour phases can indirectly affect the flow by changing either the water pressure or the density (convection). Other consequences are dealt with under mechanical processes.
- E1. Compression of water in the liquid phase is of little importance for the liquid transport processes other than for a water-saturated system, where the size of the pressure build-up associated with a temperature increase is dependent on the compressibility of the water.
- E2. Compression of air can be an important factor in the water saturation process (Boyle's Law). If the air is trapped, it must be compressed and go into solution in the water in order for water saturation to be achieved. This may take a long time since the air must be dissolved in the water and transported away by diffusion as described by process F1.
- F1. Transport of dissolved air in water. When trapped air is compressed during the water saturation phase, a portion of the volume is dissolved in the water. This solubility (Henry's Law) is approximately 2 per cent at room temperature. In order for additional air to be dissolved, the dissolved air must be transported away, which takes place by diffusion.

The occurrence of the described water transport processes depend very much on the material composition.

Water transport in the sand filling before saturation is mainly governed by the inflow rate and inflow distribution from the rock. Since the expected hydraulic conductivity of the sand is high, the resistance to water inflow into the filling material will be very low. Most processes connected with the general description of unsaturated water flow are not relevant for the sand filling. For example, the suction in the sand is insignificant and the temperature gradient is so low that there is no temperature driven vapour flow. The only relevant processes are A1, A4, A5, E2 and F1.

If the backfill is made of gravel or coarse sand the material is self-draining, meaning that water will by gravity sink to the bottom. Otherwise the water will be stuck by capillary forces until the sand is close to water saturated.

Water transport in the concrete can take place in two ways. If there are fractures in the concrete, water will easily be transported through the fractures and the same processes will occur as in the sand. The water transport in the concrete matrix is very slow due to the small size of the pores. Most processes described above are relevant for the water transport in the matrix except for the thermal ones.

If there are no cracks in the concrete and if the joints are water tight all water that is needed to fill the waste containment must go in the concrete matrix.

The nature of the cracks will decide how the flow in fractures takes place. In micro cracks the flow may be unsaturated and be similar to matrix flux. However, since the micro cracks are not well interconnected this flow will not dominate. In macro cracks the water will successively fill up the crack in a rate that is mostly determined by the access to water at the opening of the crack. The total rate of water inflow into the concrete in the macro cracks is thus mainly determined by:

- Crack frequency.
- Water accessibility at the crack openings.

Dependencies between process and system component variables

Table 5-3 summarises how the process influences and is influenced by all BMA variables. In addition, the handling of each influence in SR-PSU is indicated in the table and more thoroughly discussed in the text below.

Boundary conditions

Interaction with the rock: A key issue for the saturation process is the interaction between rock and backfill. Water is conducted to the backfill mainly in the water-bearing fractures, which means that water saturation can be uneven. However, the high hydraulic conductivity of the backfill will spread the water in the backfill at the same rate as the water inflow. If the backfill is self-draining it will be water filled like a bathtub.

Interaction between the backfill and the concrete structure: The backfill will rather soon be water filled and supply a saturated hydraulic boundary to the concrete structure. So the hydraulic boundary condition will be hydrostatic water pressure.

Table 5-3. Direct dependencies between the process “Water uptake and transport under unsaturated conditions” in BMA and the defined variables and a short note on the handling.

Variable	Variable influence on process		Process influence on variable	
	Influence present? Yes/No	Influence Description Handling of influence How/If not – Why	Influence present? Yes/No	Influence Description Handling of influence How/If not – Why
Geometry	Yes.	Geometry is included in the model.	No.	–
Temperature	No, indirectly through water viscosity.	See row water composition.	Yes, wetting and drying effects.	Negligible since the temperature gradients are very small.
Hydrological variables	Yes, basic variables.	Variables in the model.	Yes.	Variable in the model.
Mechanical stresses	Yes.	Variable in the model.	Yes.	Variable in the model.
Material composition	Yes, hydraulic conductivity and retention curve.	Sensitivity analyses.	No, but indirectly via erosion if it takes place.	No erosion is expected since the material is not sensitive to erosion.
Water composition	Yes, mainly through the viscosity.	Negligible since the change in viscosity is small.	No.	–
Gas variables	Yes, via gas pressure and degree of saturation.	Variables in the model.	Yes.	Variables in the model.

Interaction with the plugs: The plugs will seal off the BMA vault from the access tunnels and prevent water leakage from the backfill material.

Model studies/experimental studies

No studies with explicit purpose to investigate the wetting of BMA like structures have been performed, but the backfill type of materials have been investigated and used for engineering purpose in numerous tests and practices. There are also numerous examples of wetting of concrete structures in engineering practice.

Natural analogues/observations in nature

Not directly applicable since the system is engineered in a rather unique way.

Time perspective

The time until full saturation depends very much on the rock conditions and the existence of cracks in the concrete. The process is expected to be rather fast (years) but combinations of tight rock, fracture free concrete and entrapped air may prolong it to hundreds of years.

Handling in the safety assessment SR-PSU

The process water uptake and water flow in unsaturated conditions is not important for the safety assessment, unless the time to full saturation is very long (hundreds of years). Since the water inflow rate is high and the permeability of a fractured concrete is also high the time to saturation is expected to be rather short (years) but may be prolonged if air is entrapped. The risk and consequences of entrapped air will also be assessed.

If there are no cracks in the concrete and if the joints are water tight all water that is needed to fill the waste containment must go in the concrete matrix. In this case the time to full water saturation can be long.

A conceptual modelling in order to frame the time it may take to reach full saturation will be done.

Timescales: Only the time to reach full water saturation will be analysed.

Boundary conditions: The rock will be used as boundary condition. Different boundary conditions will be analysed.

Handling of variables influencing this process: All the influencing variables in Table 5-3, except temperature, will be included in the analyses

Handling of variables influenced by this process: All the influenced variables except temperature will be included in the analyses.

Handling of uncertainties in SR-PSU

The uncertainties are mainly related to the rock properties and the existence of cracks in the concrete.

Uncertainties in mechanistic understanding: The general understanding of unsaturated flow in backfill and concrete are rather good. The main uncertainties are the extent of cracking and the properties of the cracks in the concrete.

Model simplification uncertainties: Since the number, properties and time evolution of cracks in the concrete are not well known the two extremes of either completely lost barrier function of the concrete with high hydraulic conductivity or unspoiled and uncracked concrete with low hydraulic conductivity will be investigated.

Input data and data uncertainties: The properties of the concrete and rock are the most uncertain data.

Adequacy of references supporting the handling in SR-PSU

The references are judged to be adequate and sufficient to support the handling in SR-PSU. All supporting references are either peer-reviewed articles or documents which have undergone factual review. Other references have been used for general background information, and not all of these have been peer-reviewed to the same standard.

5.2.2 Water transport under saturated conditions

Overview/general description

To limit water flow through the BMA is critical for the safety since water may transport radionuclides out from the repository. The main hydraulic barrier in BMA is the concrete walls so their hydraulic conductivity is the most important safety performance indicator (see Section 3.2).

Water flow in saturated porous material is a special case of unsaturated flow. The number of processes to consider is fewer (vapour flux, phase transitions and air phases do not exist). Those processes that are involved are essentially the same as for unsaturated conditions, but can vary widely in importance when compared with unsaturated conditions.

The most important mechanism under saturated conditions is transport of water in the liquid phase, which is driven by a water pressure gradient. This transport process can be described by Darcy's Law. Any deviations from Darcy's Law, which can occur at low gradients, are favourable in that they lead to a reduced flow-through rate (e.g. Dixon et al. 1999, Hansbo 1960). The hydraulic conductivity, K , is mainly a function of the material composition, the void ratio, e , and the temperature, T .

The hydraulic conductivity of the sand or gravel backfill is rather high and ranges between 10^{-6} and 10^{-2} m/s depending on the grain size distribution (see e.g. Fagerström and Wiesel 1972). The hydraulic conductivity of concrete depends very much on the quality of the concrete. If the concrete is free from fractures the hydraulic conductivity may be very low. However, the existence of joints and probable cracks will dominate the hydraulic behaviour.

The following paragraph is taken from the reference (National Research Council (US) 2007):

“The intact (uncracked) hydraulic conductivity of Portland Cement Concrete depends primarily on the water/cement ratio, the degree of hydration, and supplemental cementitious materials or mineral admixtures (e.g. fly ash, silica fume, blast furnace slag) used in the concrete mix. The bulk hydraulic conductivity depends on the intact hydraulic conductivity and micro-structural features, including cracks in the concrete, concrete diffusivity, the internal pore system of the concrete, and the character of the cement paste-aggregate transition zone. High-strength concrete generally has a relatively low intact hydraulic conductivity, suggesting that it can provide a high degree of effectiveness as a barrier to advective flow. However, its brittleness and susceptibility to plastic shrinkage and restrained cracking create secondary features that reduce the bulk hydraulic conductivity. Hydraulic conductivity on the order of $1 \cdot 10^{-12}$ m/s is readily achievable in uncracked PCC with a low to moderate water-cement ratio. The inclusion of supplemental material, such as blast furnace slag, silica fume, and fly ash, in addition to, or as a partial replacement for Portland cement, further decreases the intact hydraulic conductivity of concrete. However, relatively few through-going cracks can increase the bulk hydraulic conductivity by several orders of magnitude compared to the intact value.”

With time the concrete is expected to degrade and the sealing effect of the concrete containment will eventually be completely lost. This will ultimately lead to a stack of residual products of mainly the ballast material with properties similar to the backfill. If there are unfilled parts inside the confinement the degradation of the roof may cause the backfill on top of the roof to fall into these empty parts and create open space at the rock roof instead.

When the BMA room has been water saturated the water transport through the room is governed by the hydraulic gradient in the surrounding rock. The high hydraulic conductivity of the backfill compared to the concrete containment will direct the water flow to go around the containment and assure a very low hydraulic gradient through the containment (hydraulic cage). The water transport through the containment and past the waste packages depends then very much on the occurrence of cracks and joints in the concrete containment. Water may also flow through permeable zones created around form ties in the concrete barriers during construction. After degradation of the concrete the hydraulic cage effect will disappear and the water will flow through the confinement.

After freezing the hydraulic conductivity will temporarily be very low, but increase after thawing due to degradation, see Section 5.1.2.

Dependencies between process and system component variables

Table 5-4 summarises how the process influences and is influenced by all BMA variables. In addition, the handling of each influence in SR-PSU is indicated in the table and more thoroughly discussed in the text below.

Boundary conditions

Interaction with the rock: A key issue for the water flow process is the interaction between rock and backfill. Water is conducted to the backfill mainly in the water-bearing fractures, which means that water saturation can be uneven. However, the high hydraulic conductivity of the backfill will make the water flow rather homogeneously in the backfill.

Interaction between the backfill and the concrete structure: The high hydraulic conductivity of the backfill will make the water flow go around the concrete and form a well-defined boundary to the concrete structure.

Interaction with the plugs: The plugs will seal off the BMA vault from the access tunnels and minimise water flow from the backfill material.

Model studies/experimental studies

There are numerous examples of water flow in concrete structures in engineering practice. Also, backfill type of materials have been investigated and used for engineering purpose in numerous tests and practices. Hence, no studies with explicit purpose to investigate the water flow in BMA like structures have been performed.

Natural analogues/observations in nature

Not strictly applicable, however water tightness of concrete structures could be seen as an analogue.

Time perspective

The process starts when the BMA has reached full saturation and continues during the rest of the BMA lifetime. The properties of the concrete will however vary during this time due to the degradation.

Table 5-4. Direct dependencies between the process “Water transport under saturated conditions” in BMA and the defined variables and a short note on the handling.

Variable	Variable influence on process		Process influence on variable	
	Influence present? Yes/No	Description Handling of influence How/If not – Why	Influence present? Yes/No	Description Handling of influence How/If not – Why
Geometry	Yes.	Geometry is included in the model.	No.	–
Temperature	No, indirectly through water viscosity.	See row water composition.	No.	–
Hydrological variables	Yes, basic variables.	Variables in the model.	Yes.	Variables in the model.
Mechanical stresses	Yes.	Negligible since the water flow rate is low.	Yes.	Negligible.
Material composition	Yes, through hydraulic conductivity.	Sensitivity analyses.	No but indirectly through, transport of degraded cement.	See advection, Section 5.4.1.
Water composition	Yes, mainly through the viscosity.	Negligible since the change in viscosity is small.	No, but indirectly through transport of dissolved cement species.	See advection, Section 5.4.1.
Gas variables	No, since the process assumes water saturation.	–	No.	–

Handling in the safety assessment SR-PSU

The process water flow under saturated condition will be decisive in for many processes in the safety assessment. The magnitude of water flow through the confinement is expected to vary with time and increase successively when the concrete containment is degraded.

The following handling in the safety assessment is anticipated:

1. Definition of the initial state with specification of concrete quality, backfill material and containment design.
2. Investigation of the degradation rate of the concrete, which may be a function of several factors.
3. Determination of the hydraulic properties of the degraded concrete.
4. Modelling of the water flow through the BMA repository with different hydraulic boundary conditions.

Timescales: The entire life time of the repository will be included. The concrete degradation process is described by several degradation states.

Boundary conditions: The rock will be included in the model. Different rock structures and boundary conditions will be used.

Handling of variables influencing this process: All the influencing variables, except temperature, will be included in the analyses

Handling of variables influenced by this process: All the influenced variables except temperature will be included in the analyses.

Handling of uncertainties in SR-PSU

Given the adopted handling in the safety assessment SR-PSU as described above, the handling of different types of uncertainties associated with the process will be summarised.

Uncertainties in mechanistic understanding: The general understanding of saturated flow in back-fill and concrete are rather good. The uncertainties are mainly related to the rock properties and the existence of cracks in the concrete, the degradation rate of the concrete and the hydraulic properties of the degraded concrete.

Model simplification uncertainties: The water flow in the concrete will be simplified to water flow in a porous media with properties that vary with time according to the expected degradation rate.

Input data and data uncertainties: The properties of the cracks in the concrete, the degradation rate and the properties of the degraded concrete are uncertain data.

Adequacy of references supporting the handling in SR-PSU

The references are judged to be adequate and sufficient to support the handling in SR-PSU. All supporting references are either peer-reviewed articles or documents which have undergone factual review. Other references have been used for general background information, and not all of these have been peer-reviewed to the same standard.

5.2.3 Gas transport/dissolution

Overview/general description

After the BMA is sealed, groundwater will seep in from the surrounding rock, gradually filling the empty voids and pores of the barriers and the waste. This will take place over a period of a few years (Holmén and Stigsson 2001) until the water pressure in the repository is equal to that in the surrounding rock. Gas may become trapped in the BMA vault during this re-saturation phase and gas will also form within the waste (**Waste process report**) and, to a lesser extent, in the barriers (see Section 5.4.10). This section describes the dissolution and transport of gas in the BMA barriers and the mechanisms for gas release from the repository.

Dissolution and water-phase transport of gas

Some of the gas trapped or produced in the BMA will dissolve in the porewater of the barrier. Gas solubility in water varies between different gases, and the amount of gas that dissolves is proportional to its partial pressure (Henry's Law). When the water phase reaches its saturation limit, no more gas will dissolve. The transport of dissolved gas is controlled by diffusion (Section 5.4.2) and/or advection (Section 5.4.1). Certain gases react chemically with the water or components dissolved in the water. Carbon dioxide is of particular importance as it forms carbonate, which may in turn precipitate as calcite. Therefore, carbon dioxide formed in the BMA vault, along with other reactive gases, will be dissipated through chemical transformation as well as physical transport pathways.

Gas accumulation and transport

Essential parts of the descriptions in this section have been extracted and, when required, modified from Moreno et al. (2001).

Gas cannot flow freely through water saturated porous media such as concrete. Therefore, the presence and on-going formation of gas in the BMA can result in an accumulating gas phase. In the early stages after repository closure, gas accumulation may influence the flow of groundwater and affect the re-saturation of the BMA vault, see Section 5.2.1. More serious implications however, come after the BMA has re-saturated and gas formation increases the internal pressure. Gas release may occur via fractures in the concrete barriers, through open joints between different barrier components, or through gas-filled pore systems in the concrete barriers. The build-up of gas pressure in the system and subsequent release of gas could result in partial displacement of porewater from BMA vault. Penetration of gas through the saturated concrete would cause a displacement which pushes the porewater through the barrier towards the geosphere and increases the likelihood of radionuclide release. A certain gas pressure needs to be established in order for water to be expelled, and this depends on the hydraulic conductivities of the barrier materials and the surrounding rock.

The pore structure of a material affects the pressure required to displace porewater because of the high capillary pressures associated with fine pores and fractures (Equation (5-7)), which may be as large as many tens of atmospheres. Fine pores will therefore draw water in from the surroundings against a considerable gas pressure. In saturated concrete, the capillary pressure holds water in the pores and allows the gas pressure to build up until it reaches a level sufficient to expel water from the pores.

$$P_c = \frac{2 \cdot \sigma}{r} \quad (5-7)$$

where:

P_c = the capillary pressure (Pa)

σ = the surface tension (N/m)

r = the capillary radius (m).

As the gas pressure increases in response to continuing accumulation of produced gas, first the water in the largest pores is displaced and then gradually in smaller and smaller pores until a balance is reached between the gas transport capacity and the gas formation rate. The pressure drop due to gas flow through a concrete barrier is proportional to the thickness of the concrete; hence the geometry of the barrier is of importance in the evaluation. Depending on the pore size distribution and the structure of the material, the amount of water expelled at a given rate of gas formation may vary considerably.

As water is expelled from the pores, a network of connected gas-filled pores and fractures is created. These will eventually connect to the geosphere, creating a flow path by which gas can leave the repository. Gas release is dependent on the fracture system of surrounding rock, but estimates show that only a few rock fractures are required to release the gas generated in a repository (Braester and Thunvik 1988). The presence of gas flow paths allows the pressure in the system to equilibrate, and prevents further expulsion of water. A possible consequence of gas release is that radioactive gases may also be transported to the biosphere. For transport of radionuclides in the gas phase see Section 5.5.3.

High quality construction concrete has a very fine pore structure, which means that pressures as high as 1.5 MPa must build up before water is expelled and gas can flow (Möller et al. 1981). The concrete structures in SFR are not designed to tolerate such high pressures. Small fractures in the concrete are therefore beneficial, as they offer lower resistance to the gas and prevent pressure-induced damaged. For example, gas flow may be established with an overpressure of only 15 kPa in fractures with apertures of 10 μm (Moreno et al. 2001).

Fate of gas formed in the BMA barrier

The porewater of the barriers is not expected to be contaminated with radionuclides for the initial post-closure period. Thus very early gas generation is not expected to result in the expulsion of significantly contaminated water from the pores. With time the pore water will be contaminated by radionuclides released from the waste, and expulsion of this water is of more concern.

The gas generated in the BMA concrete barriers will escape through the most accessible pathway, i.e. through permeable zones created around reinforcement bars and supporting form rods left in the concrete barriers during construction, through fractures and joints between different construction parts. The presence of permeable zones reduces the likelihood that high pressures will build up, particularly since the gas formed in the barriers comes predominately from the corrosion of reinforcement bars and the metal rods that create greater permeability. Also, significant fracturing has been observed in the BMA concrete barriers, which indicates the presence of gas permeable pathways. If these pathways are not available to a part of the gas that forms, the gas will accumulate as a function of the capillary pressure of the concrete, and may eventually result in fracture formation.

Dependencies between process and system component variables

Table 5-5 shows how the Gas transport/dissolution processes in BMA concrete barriers influence, and are influenced by, all variables of the concrete barriers, the vault and backfill.

Influence by geometry

Yes, a direct influence has been identified.

The geometry of the concrete barriers affects the process directly since the flow resistances of the concrete walls are proportional to their thickness. Pressurisation due to the accumulation of trapped gas will depend on the rate of water displacement, which in turn is determined by the flow resistance of the concrete. The cross-sectional area for flow is inversely proportional to the pressure field necessary to displace the water.

Also the pore geometry, the presence and size of fractures, and the presence of any gaps between different construction parts, will have a direct impact on gas flow as they control the capillary pressure of the concrete. The capillary pressure determines the retention of pore water in the backfill and concrete barriers, which directly influences the amount of water that will be displaced at any given gas pressure, and the critical gas pressure required to initiate gas flow.

The geometry of the vault and backfill will have a direct impact on the flow pattern of gas in the BMA barriers and will define the interface between the BMA vault and the surrounding rock through which the gas needs to escape.

Influence on geometry

No direct influence has been identified.

There is an indirect effect via gas pressure and pressurisation, since the pressure required to initiate gas flow through the saturated concrete in the BMA may exceed pressures at which the concrete barriers fracture. More detailed descriptions of the mechanisms leading to fracture formation due to mechanical stresses are given in Section 5.3.1.

Table 5-5. Dependencies between the processes “Gas transport/dissolution” in concrete barriers, vault and backfill in BMA and different system component variables.

Variable	Variable influence on process		Process influence on variable	
	Influence present? Yes/No Description	Handling of influence How/If not – Why	Influence present? Yes/No Description	Handling of influence How/If not – Why
Geometry	Yes, geometry influences the flow resistance and the capillary pressure that need to be exceeded to release gas.	Included in the gas transport modelling.	No, but there is an indirect effect via gas pressure and gas pressurisation that may cause fracture formation.	See Section 5.3.1.
Temperature	Yes, temperature influences the volume, density and viscosity of gas and water.	Temperature is considered in the selection of data for gas transport modelling.	Yes, but effects are judged negligible.	Neglected due to insignificant impact.
Hydrological variables	Yes, the water flow determines the dissipation of dissolved gas. Capillary characteristics determine the gas pressure build-up.	Included in the gas transport modelling.	Yes, the accumulation of gas will redirect water flow and could result in displacement of contaminated water.	Included in the gas transport modelling.
Mechanical stresses	No, but mechanical stresses may have an indirect influence via porosity, occurrence of fractures and hence gas transport properties.	Considered in the selection of data for certain scenarios for gas transport modelling.	No, although gas pressurisation resulting from limited gas transport may influence mechanical stress Section 5.3.1.	
Material composition	Yes, the material composition determines the gas transport properties and capillary retention of pore water.	Considered in the selection of data for gas transport modelling.	No, although there is an indirect influence via water composition, since dissolved carbon dioxide may cause calcite precipitation that may block pores and fractures.	See Section 5.4.6.
Water composition	Yes, water composition influences the dissolution of gas. Density and viscosity of water affects the displacement of water by gas.	Considered in the selection of data for gas transport modelling.	Yes, dissolution of gases will affect the water composition. Also, carbon dioxide will influence the pH. Radioactive gas may dissolve in water.	Included in gas transport modelling.
Gas variables	Yes, fundamental parameters for the gas transport.	Considered in the selection of data for gas transport modelling.	Yes, a fundamental impact on the gas variables.	Considered in the selection of data for gas transport modelling.

Influence by temperature

Yes, a direct influence has been identified.

Temperature directly influences the volume of gas via the general gas law. The temperature also affects the density and viscosity of water and gas and thereby the flow resistance of water and gas. The temperature may also influence the solubility of gas in the water.

Influence on temperature

Yes, a direct influence has been identified.

Gas transport can involve heat transfer. However, SFR will be at the ambient temperature, thus transport of heat by escaping gases is thought to be negligible, and will have no impact on the temperature of SFR. Heat exchange due to compression of gas in the repository and subsequent expansion during escape through the concrete barriers is also judged to have a negligible impact.

Influence by hydrological variables

Yes, a direct influence has been identified.

The magnitude and distribution of water flow will have a direct influence on the amount of gas that can dissolve and be transported away by the flowing groundwater.

The degree of saturation has a direct influence on the transport of gas in the concrete barriers, as well as in the backfill. For unsaturated conditions the gas may, to some extent, flow through the barriers and backfill without the restriction of overcoming the capillary pressure. Under saturated conditions, the pores and fractures are blocked by water and the capillary pressure must be exceeded in order to enable transport of gas. The degree of saturation also determines the maximum transport capacity of gas in a porous or fractured material. At any given gas pressure, the corresponding degree of saturation can be determined and used in estimates of the gas permeability given by different constitutive relationships referred to as relative permeability functions.

During permafrost and/or glaciation, the pore water may freeze and block the pores, hence prevent the transport of gas through the barriers and the backfill. However, under these conditions it is also likely that the gas formation processes would halt (see Section 5.4.10).

Influence on hydrological variables

Yes, a direct influence has been identified.

The generation of a gas phase and the paths the gas will find to escape the BMA vault will have a direct influence on the magnitude, direction and distribution of water flow in the concrete barriers and the backfill. At locations where gas penetrates the pores/fractures the flow of water will cease or be restricted, hence water transport will be affected. Water will be displaced if the gas pressure increases above a certain level, which will increase the risk of contaminant release from the vault into the groundwater.

The displacement of porewater in the concrete barriers/backfill as a consequence of gas accumulation and gas transport may introduce locally unsaturated zones, which will also directly influence the amount of water in the BMA barrier. During periods of rapid gas accumulation/displacement, the water pressure in the BMA barriers may increase, particularly where there is high capillary pressure in the barrier.

Gas transport and dissolution of gas is not expected to influence the aggregation state of water and/or ice.

Influence by mechanical stresses

No direct influence has been identified.

Mechanical stresses in the barrier materials could result in compression which may influence the porosity and the pore geometry and therefore affect the gas transport properties indirectly via geometry.

Influence on mechanical stresses

No direct influence has been identified.

The build up of gas resulting from limited outward transport will lead to gas pressurisation, which may influence the mechanical stresses in the barrier materials. Since fractures have already been observed in the BMA concrete barriers, the likelihood of significant pressure build-up inside the concrete barrier is low. More detailed descriptions of the impact of mechanical stresses are given in Section 5.3.1.

Influence by material composition

Yes, a direct influence has been identified.

The amount and composition of the barrier materials have a direct influence on the gas transport properties. As an example, the water to cement ratio in the concrete will determine the total porosity and the size distribution of the concrete pores. Also the grain size distribution of the material selected for the backfill may have a direct impact on the capillary retention characteristics. This in turn will determine the likelihood of pore water displacement as a result of accumulation of gas in the BMA vault.

The chemical composition of the barrier material has an indirect impact via water composition on the absorption of carbon dioxide that may form in the BMA vault through the microbial degradation of organic compounds in the waste and waste packaging. This would reduce the amount of carbon dioxide gas pressurising the BMA vault. Degradation, could however also potentially lead to sealing of porosity, which could decrease the gas permeability.

Influence on material composition

No direct influence has been identified.

Indirectly, via the system variable “water composition” and precipitation (Section 5.4.6), the exposure of cementitious materials to carbon dioxide may result in the precipitation of calcite. This may result in blocking of pores, fractures and other voids, which could affect the transport of other gases, such as hydrogen.

Influence by water composition

Yes, a direct influence has been identified.

The chemical composition of the water has a direct impact on the dissolution of carbon dioxide that may form in the BMA vault due to microbial degradation of organic compounds in the waste and waste packaging. This would reduce the amount of gas in the BMA vault.

The amount of gas dissolved in the water affects the rate of dissipation of gas from the BMA vault through advective groundwater flow and diffusion.

The density and viscosity of the water have a direct influence on the flow properties of water and hence influence the gas pressures required to displace pore water following gas accumulation in the barriers.

Influence on water composition

Yes, a direct influence has been identified.

The dissolution of gas will directly influence the water composition. In the case of carbon dioxide this would directly influence the pH of the water. Dissolution of hydrogen will have an impact on the redox conditions in the water.

Dissolution of radioactive gases would affect the radionuclide content of the water.

Influence by gas variables

Yes, a direct influence has been identified.

This process is fundamentally determined by the gas variables.

Influence on gas variables

Yes, a direct influence has been identified.

This process has a fundamental and essentially defining influence on the gas variables.

Boundary conditions

The relevant boundary conditions in order to treat the process quantitatively are those of the transport processes that control the formation of gas in the waste and barrier materials, see Section 5.4.10, but also the solutes transport between the cement matrix, the waste, the concrete packaging and the groundwater as adjacent system components, i.e. the boundary conditions of the processes diffusion (see Section 5.4.2) and advection (see Section 5.4.1).

Model studies/experimental studies

Model studies of effects of gas pressurisation and gas transport from different parts of the SFR facility has been made for different scenarios (Moreno et al. 2001). Data of relevance for characterisation of the gas transport properties of different barriers in SFR, such as barrier thickness, pore volume and void volume, have been compiled in Moreno et al. (2001).

A comprehensive review of capillary effects and multiphase flow in porous media is presented by Dullien (1998). Different models are used to describe the capillary phenomena. Davies et al. (1992) used a capillary tube model and an empirical correlation for the intrinsic permeability to estimate the threshold pressure. Several models using empirical or semi-analytical correlations to represent the relationship between capillary pressure and saturation are found in the literature (Resele and Illi 1992, Rodwell and Nash 1992). A general-purpose numerical simulation program for multiphase, multi-component fluid and heat flow in porous and fractured media, TOUGH (Pruess 1987) and TOUGH2 (Pruess 1991) has been also used to study the gas impact in waste repositories.

Gas accumulation and gas transport from a Swiss repository for L/ILW has been modelled using a capillary bundle model (Wiborgh et al. 1986).

In order to study the impact of uncertainties in different input parameters, a probabilistic model has been developed and applied to gas release through repository barriers and plugs (Höglund et al. 1997).

In the case of materials with a fine pore structure such as concrete, capillary forces are of importance for the pressure that needs to be built up to expel the gas. Water will be expelled from the concrete until a network of empty pores has been formed for transport of the gas. When gas-conducting passages have been formed in the barrier, the gas flows out as long as the pressure difference exceeds the capillary pressure. The capillary pressure in an intact structural concrete is of the order 1–2 MPa. If the structural concrete has small fractures, less pressure is required to expel the gas. A pressure of 1–2 kPa is required for a planar fracture with an aperture of 0.1 mm, while a pressure of about 15 kPa is required for a 10 µm fracture (Moreno et al. 2001). In concrete packages and concrete structures, a number of small fractures is sufficient to expel all the gas.

The Backfill and Plug Test in the Äspö HRL (Gunnarsson et al. 2001) includes a full scale test where the hydraulic properties of crushed rock as backfill material (which is a possible backfill in the BMA vault) are investigated. However, the information on trapped gas from that experiment is limited.

In the case of a gravel fill, only small pressures are required to open up transport pathways and to drive the gas through the porosity in the fill. Gas that has flowed through gravel fill and made it to the void beneath the roof in the silo repository and the rock vaults can then be further transported in fractures in the surrounding rock (SKB 2010b).

Gas transport in the engineered barriers in a repository for intermediate-level waste has been studied on a field scale in the Gas Migration Test (GMT) (Shimura et al. 2006). The test started in 1997 in Nagra's underground laboratory in Grimsel, Switzerland. The field tests were concluded in 2004 and most of the evaluations and modellings have also been concluded. The test was conducted in a special-purpose concrete silo with a bentonite/sand barrier fitted with a gas valve. Two phases of gas tests were conducted in GMT. Before, between and after the gas tests, hydraulic tests were performed to see whether the properties of the engineered barriers were altered due to the gas breakthroughs. The following conclusions have been drawn from the GMT tests in Grimsel:

- Gas could be transported through the valve to the geosphere at relatively high flows and low pressures.

- The function of the bentonite/sand barrier (present in these tests) was not adversely affected by the gas. No change could be detected in the hydraulic properties.
- The volume of water that was expelled from the concrete structure (a silo) during the gas tests was very small (about one percent of the total injected gas volume).

The fate of gases formed in nuclear waste repositories has been the subject of studies within the EURATOM project FORGE 2009, giving a state-of-the art description on modelling of gas transport in engineered barriers and geological systems (Popp 2009).

Natural analogues/observations in nature

Not applicable.

Time perspective

The relevant time scales for dissolution and transport of gas in the BMA vault are determined by:

- The time to resaturate the repository by inflowing groundwater, considering also the escape of entrapped air in the repository (expected to be completed within a few years – a few decades after closure),
- the onset of gas formation. Small amounts of gas may form via radiolysis and microbial degradation from the operational period onwards. However, large scale gas generation will occur during the anaerobic corrosion of steel, with the evolution of hydrogen. This will initiate within a few years post closure, following the depletion of the residual oxygen from the repository, and
- the termination of gas formation when organic material has degraded and steel has been completely corroded (a gradual decrease in gas formation rate over time is expected and a complete stop after a few thousand years). At this time the gas transport will cease.

Handling in the safety assessment SR-PSU

The gas transport and the quantity of water expelled from the BMA vault are determined by the design of the barriers and the properties of the barrier materials. The presence of gas in the BMA vault will influence the flow of water, and since water is the primary media for the release of radionuclides this is considered in the safety assessment.

During accumulation of gas and pressure build-up in the vault, pore water will be displaced. This pore water may be contaminated by radionuclides and may lead to an increased release to the groundwater in the rock. Radionuclide release through the displacement of contaminated pore water by gas is quantified in model calculations considering the effects of gas accumulation and the conditions for gas release. Since the prediction of gas generation over time is difficult to assess in detail, the gas accumulation and release calculations are studied for different scenarios.

Handling of uncertainties in SR-PSU

A rather complete summary of the uncertainties related to gas formation and migration in performance assessment exercises is given in Norris (2008) and a presentation on how the gas-related processes is handled in different performance assessments can be found in Norris (2009).

Uncertainties in mechanistic understanding: The basic understanding of gas dissolution and transport processes are fairly mature, hence the uncertainties related to the mechanistic understanding are judged to be small.

Model simplification uncertainties: The major uncertainties in the model simplifications are related to the representation of the complex geometry of the different barriers in the BMA repository, the pore geometry of the barriers, the presence and model representation of fractures in the concrete barriers, and the possible impact of shotcrete on gas dissipation into the surrounding rock. The impact of model uncertainties is explored by studying different scenarios.

Input data and data uncertainties: The major uncertainties introduced by the selection of input data and the related data uncertainties are the amount and characteristics of fractures in the concrete barriers, the capillary pressure characteristics of different materials in the BMA vault, the gas transport properties of the different barrier materials at different degrees of water saturation as well as the evolution of these properties over time, and the gas transport properties of shotcrete after closure. The data uncertainties are reduced as much as possible by characterisation of the appropriate materials. Remaining uncertainties are handled by parameter variations and probabilistic modelling of the gas release for different scenarios.

Adequacy of references supporting the handling in SR-PSU

The references are judged to be adequate and sufficient to support the handling in SR-PSU. All supporting references are either peer-reviewed articles or documents which have undergone factual review. Other references have been used for general background information, and not all of these have been peer-reviewed to the same standard.

5.3 Mechanical processes

5.3.1 Mechanical processes

Changes in stress conditions in the concrete barriers may cause cracking.

External and internal load will change the stress in the barriers. Examples of internal load are swelling and gravitation. Change in stress and loss of structural integrity may cause deformation and redistribution.

Overview/general description

A number of mechanical processes may occur in the backfill and the concrete containment. The following is a list of mechanical processes in the **backfill of sand**:

- Stresses caused by the own weight of the backfill.
- Hydraulic stresses.
- Settlement by wetting.
- Deformation caused by stress changes.
- Creep deformations.
- Effects of concrete degradation.
- Effects of displacements and fall out in the roof and walls of the rock vault.
- Effects of freezing.
- Stresses caused by gas formation.

When the backfill is water unsaturated the capillary forces between the grains may affect the stresses from the own weight of the backfill to such an extent that the backfill will be kept at a loose structure if the emplacement is done without compaction. When the backfill gets water saturated the capillary forces will disappear and the backfill may settle into a higher density and leave a slot at the roof.

After full water saturation the effective stress is governing the mechanical behaviour. The effective stress is the difference between the total stress and the water pressure according to Equation (5-8) (see e.g. Hansbo 1975).

$$\sigma' = \sigma - Au \tag{5-8}$$

where

σ' = effective stress

σ = total stress

u = porewater pressure

A = 1.0 for normal soils

The mechanical properties of the backfill sand depend mainly on the grain size distribution and the density. The density is in turn a function of the grain size distribution, the grain particle form and the compaction effort (see e.g. Andreasson 1973).

The **concrete** may also be affected by a number of mechanical processes:

- Stresses caused by the own weight of the concrete, the backfill and the waste packages.
- Hydraulic stresses.
- Deformation caused by stress changes.
- Creep deformations.
- Effects of concrete degradation caused by chemical processes.
- Indirect effects of displacements and fall out in the roof and walls of the rock vault.
- Stresses caused by corrosion of the steel reinforcement.
- Stresses caused by a swelling waste form.
- Cracking.
- Effects of freezing.

Many of these processes are, however, insignificant for the mechanical function of the BMA.

In the long time perspective the concrete is expected to crack and be degraded by chemical processes. This will ultimately lead to a stack of residual products of mainly the ballast material with mechanical properties similar to the backfill.

Dependencies between process and system component variables

Table 5-6 summarises how the mechanical processes influence and are influenced by all BMA variables. In addition, the handling of each influence in SR-PSU is indicated in the table.

Table 5-6. Direct dependencies between the mechanical processes in BMA and the defined variables and a short note on the handling.

Variable	Variable influence on process		Process influence on variable	
	Influence present? Yes/No Description	Handling of influence How/If not – Why	Influence present? Yes/No Description	Handling of influence How/If not – Why
Geometry	Yes.	Included in the model.	Yes, since stresses always cause displacements.	Negligible since the displacements are small.
Temperature	Yes.	Negligible, since temperature changes and gradients are small.	No.	
Hydrological variables	Yes, e.g. the stresses change when the vault is filled with water.	Included in HM models.	Yes, displacements may cause water pressure changes.	Included in HM-models, but very small.
Mechanical stresses	Yes, since stresses cause displacements and creep.	Included in HM models.	Yes, since displacements cause stresses.	Included in HM models.
Material composition	Yes, determines the properties.	Sensitivity analyses.	No.	
Water composition	Indirectly through chemical effects on the concrete, which will be degraded.	See Section 5.4 Chemical processes. The change in barrier function will be analysed.	No.	
Gas variables	Yes, gas pressure may be generated and cause stresses.	Will be modelled.	No.	

Boundary conditions

The BMA has the rock as boundary. The different parts of the BMA have several boundaries.

Backfill

The backfill has the rock as a mechanical fixed outer boundary except for the process of rock fall out and rock displacements. The inner boundary of the backfill is the concrete structure, which may interact mechanically with the backfill. The most important interactions are the effects of concrete degradation and the gas generation from inside the concrete structure.

Concrete

The concrete has the backfill, the waste moulds and the rock under the structure as boundaries. There is an interaction with the backfill (see above). There is also an interaction with the waste packages mainly through the gas production but also by the degradation of the concrete. The rock under the structure behaves like a fixed mechanical boundary.

Plugs

The plugs will seal off the BMA vault from the access tunnels and prevent water leakage from the backfill material. However, the mechanical interaction will be considerable. There is a transition material between the backfill in the BMA and the bentonite plugs and this material will be compressed by the swelling bentonite. This will also lead to some compression of the backfill in the BMA. See also Section 10.3.1.

Model studies/experimental studies

No studies with explicit purpose to investigate the mechanical processes in BMA like structures have been performed, but the backfill type of sand materials and concrete structures have been investigated and used for engineering purpose in numerous tests and practices.

Natural analogues/observations in nature

It is generally hard to find relevant analogues for mechanical processes in engineered systems.

Time perspective

See handling in the safety assessment.

Handling in the safety assessment SR-PSU

Some of the mechanical processes may affect safety and will be included in the safety assessment. All subprocesses listed under overview/description will be commented on.

Backfill of sand

- Stresses caused by the own weight of the backfill.
- Settlement by wetting.

These processes will be analysed since the effect of a slot at the roof must be considered and included in the water flow modelling.

- Hydraulic stresses.
- Creep deformations.

These are small and will not be considered. The hydraulic stresses after saturation are small since there are very small hydraulic gradients. Sand is not sensitive to creep.

- Effects of concrete degradation.

Will be analysed, see also Section 5.4.6.

- Effects of displacements and fall out in the roof and walls of the rock vault.

Will be analysed. Rock pieces in the roof may fall down and compact the backfill, which leads to open slots at the remaining roof.

- Effects of freezing.

Will be analysed, see also Section 5.1.2 Phase changes/freezing.

- Stresses caused by gas formation.

Will be analysed, see also Section 5.2.3 Gas transport/dissolution.

- Deformation caused by stress changes.

Will be analysed in connection with the other mechanical processes.

Concrete

- Stresses caused by the own weight of the concrete, the backfill and the waste packages.

Will be neglected before degradation but after degradation these stresses may cause settlement and additional opening of the slot at the roof. This will be analysed.

- Hydraulic stresses.
- Creep deformations.

These are small and can be neglected. The hydraulic stresses after saturation are small since there are very small hydraulic gradients. Concrete is not sensitive to creep.

- Effects of concrete degradation caused by chemical processes.

This is an important process that will have impact on the integrity of the BMA. The process is handled in Section 5.4 Chemical processes. If the concrete degradation is strong the possible change in barrier function will be analysed.

- Indirect effects of displacements and fall out in the roof and walls of the rock vault.

Not very strong effects and may probably be neglected since it will only cause small changes in properties of the sand.

- Stresses caused by corrosion of the reinforcement.
- Stresses caused by a swelling waste form.
- Cracking.

These will contribute to the degradation and the handling is described under chemical processes (Section 5.4.6).

- Effects of freezing.

Will contribute to the degradation and will be analysed, see Section 5.1.2 Phase changes/freezing.

- Stresses caused by gas generation.

These will probably be small since the gas can escape through the concrete cracks but this process must be investigated (see Section 5.2.3 Gas transport/dissolution).

- Interaction with the waste packages.
- Deformation caused by stress changes.

Can be disregarded before the concrete degradation but may be important during and afterwards.

The concrete will crack and completely change its properties with time. The degradation rate and rest product should be investigated in order to predict the change in properties with time. The concrete may be modelled as completely degraded with properties similar to sand after a certain time.

Timescales: The entire life time will be included. The processes can be divided into two different time periods; before and after degradation of the concrete.

Boundary conditions: The rock will constitute the boundary in the analyses.

Handling of variables influencing this process: All the influencing variables, except temperature, will be included in the analyses.

Handling of variables influenced by this process: All the influenced variables will be included in the analyses.

Handling of uncertainties in SR-PSU

Given the adopted handling in the safety assessment SR-PSU as described above, the handling of different types of uncertainties associated with the process will be summarised.

Uncertainties in mechanistic understanding:

Backfill

The mechanical properties of sand fills are well known and the related mechanical processes well understood.

Concrete

The mechanical properties of the un-degraded concrete are well known and the mechanical processes well understood. The properties during and after degradation are more uncertain. A way to overcome these uncertainties may be to treat the concrete as completely degraded and turned into a sand heap after a certain time.

Model simplification uncertainties: The lack of knowledge of the properties of the degraded concrete may make it necessary to treat the concrete as completely degraded and turned into a sand heap after a certain time.

Input data and data uncertainties: See model simplifications.

Adequacy of references supporting the handling in SR-PSU

The references are judged to be adequate and sufficient to support the handling in SR-PSU. All supporting references are either peer-reviewed articles or documents which have undergone factual review. Other references have been used for general background information, and not all of these have been peer-reviewed to the same standard.

5.4 Chemical processes

5.4.1 Advection and dispersion

Overview/general description

Solutes can be transported to and from the interior of the concrete barriers in the BMA repository by advection and diffusion (see further Section 5.4.2). See also Section 5.5.2 for the handling of radionuclide transport in the water phase.

Advection

In this report, advection refers to the transport of a dissolved substance by the bulk flow of water. The evolution of the groundwater flow conditions in the barriers will therefore have a direct and important impact on the advective transport of dissolved species. For BMA, the safety function of limited advective transport applies (see further Section 3.2), and the performance indicator for this safety function is the hydraulic conductivity of the barriers. The hydraulic conductivity strongly relates to the local groundwater flow, which is driven by pressure gradients and is affected by the properties of the media, such as the permeability, porosity and presence of cracks, and the fluid properties, such as the density and viscosity. The processes of water transport in BMA under unsaturated and saturated conditions are described separately in Sections 5.2.1 and 5.4.2, respectively.

The relative importance of advective and diffusive transport of solutes through the barriers is obtained implicitly in the solute transport models used in SR-PSU, which include both mechanisms. It can also be evaluated by means of the dimensionless Péclet number (see further Section 5.4.2), which provides a measure of the ratio between the rates of these two transport mechanisms. Solute transport in the concrete barriers in BMA may be diffusion controlled under initial state conditions. However, these constructions may undergo chemical degradation and physical changes, such as cracking, over time that affect their pore characteristics and hydraulic properties. Therefore, the relative rates of advective and diffusive transport are expected to change over time.

After the operational period when pumping ceases, the void spaces in the repository will fill with groundwater primarily via gravitational flow (see Section 5.2.1). During resaturation, the advective transport will be directed inwards from the surrounding rock, and hence dissolved species emanating from the waste form are not expected to be discharged through the barriers to the geosphere.

Following this initial period, when the vaults, barriers, backfill, and waste packages have become saturated with groundwater, the extent and direction of advective transport of substances is governed by their dissolved concentrations and the water flow.

Climate changes during the first 1,000 years after repository closure are not expected to affect temperature to any significant degree; therefore no important temperature induced changes with influence on advective transport are expected. However, during periods of permafrost and glaciation, temperature in the repository will decrease to a point where the entire repository freezes and water flow ceases, see Section 5.1.2. The internal freezing can cause penetrating cracks in concrete presumably causing important structural deterioration, see Section 5.3.1. Hence, the concrete barriers may become deteriorated as a result of freezing processes to a degree that the function as barriers against advective transport is compromised (see Section 3.3 for a description of the safety function).

Hydrodynamic dispersion

The transport of solutes by advection is also affected by hydrodynamic dispersion, which here refers to the net effects of small-scale variations in the flow field, in combination with molecular diffusion and mechanical mixing. Dispersion results in a spread of dissolved substances relative to the advective bulk flow of water, and can occur in the direction of flow or perpendicular to the flow direction. The dispersion effect is caused by different processes such as:

- Velocity distribution in single flow channels.
- Mixing of water transported by different flow channels.
- Distributed flow channel sizes (pore sizes) leading to different velocities distributions in different flow channels.
- The presence of materials with different hydraulic conductivities giving rise to distributed flow velocities in different materials.
- The effects of diffusion processes caused by Brownian motion of dissolved substances in the water.

In a single flow channel (or pore), typically the highest velocity is found in the centre of the flow channel and a velocity approaching zero near the channel wall. In materials with distributed channel (or pore) sizes, the velocity distribution in each of the channels will be different, with the highest flow expected in the largest channels. When materials with different hydraulic conductivities are present and water flow is parallel to the interface between the different material boundaries, the water flow will be distributed essentially in proportion to the hydraulic conductivity. For flow perpendicular to the material boundaries, the flow will be essentially equal in the different materials, governed by the least permeable material, and the impact on the dispersion processes will be small.

In solute transport modelling, dispersion effects are often represented mathematically by a dispersion factor, which intends to capture the dispersive effects on scales beneath that modelled explicitly by the flow field. For porous media, dispersion is sometimes represented using a Fickian approach in modelling, assuming diffusion-like behaviour (see Section 5.4.2) with a flux proportional to the gradient in solute concentration. However, this approach is not necessarily accurate because it does not explain the observed scale-dependency of dispersivities. Quantifying dispersion by inclusion in simplified advection–dispersion transport models therefore involves conceptual uncertainties.

Dependencies between process and system component variables.

Table 5-7 shows how the advection and dispersion processes influence, and is influenced by, all defined BMA system variables. In addition, the handling of each influence in SR-PSU is indicated in the table and more thoroughly discussed in the text below. The system variables and their definition within this report are presented in Section 4.3.

Influence by geometry

No direct influence has been identified.

Advection will be affected indirectly through water transport (Sections 5.2.1 and 5.2.2), by the geometric dimensions, porosity and pore characteristics of the barrier, as well as the frequency and size of fractures.

Dynamic changes such as chemical degradation, and corrosion of residual metals will further affect the geometric parameters, which will in turn influence advective transport indirectly through water transport (see further discussions in Sections 5.4.6 and 5.4.9).

Influence on geometry

No direct influence has been identified.

Indirectly, the advective transport of reactants present in the groundwater and in the waste may result in chemical dissolution/precipitation/recrystallisation processes in the concrete barriers and backfill materials and corrosion of residual metals (Sections 5.4.6 and 5.4.9) that may influence the porosity.

Influence by temperature

No direct influence has been identified.

Temperature may affect water transport (Sections 5.2.1 and 5.2.2) by thermal convection through changes in the fluid density. This would indirectly influence advective transport. The effect is however judged to be negligible due to small temperature variations within the barriers and between different parts of SFR.

Influence on temperature

No direct influence has been identified.

Heat may be redistributed in the barriers as a result of water transport (Sections 5.2.1 and 5.2.2), and the mixing of different waters. Heat transport is further considered in Section 5.1.1.

Table 5-7. Dependencies between the advection and dispersion processes and the BMA system component variables.

Variable	Variable influence on process		Process influence on variable	
	Influence present? Yes/No Description	Handling of influence How/If not – Why	Influence present? Yes/No Description	Handling of influence How/If not – Why
Geometry	No direct influence. Barrier dimensions, porosity and pore characteristics affect the hydraulic properties (i.e. hydraulic conductivity in the barriers), which influence advective transport indirectly through water transport.	Indirect influence of geometry is handled under water transport in Sections 5.2.1 and 5.2.2.	No direct influence. Indirect effect of advection-induced changes in water chemistry is considered in Section 5.4.6.	
Temperature	No direct influence. Temperature affects thermal convection of groundwater through changes in density.	Indirect influence of temperature is handled under water transport in Sections 5.2.1 and 5.2.2.	No direct influence. Temperature is influenced by redistribution of heat due to water transport, see Sections 5.1.1, 5.2.1 and 5.2.2.	
Hydrological variables	Yes, magnitude, direction and distribution of water flow have a direct influence on advective transport.	Magnitude, direction, and distribution of water flow are variables included in near-field hydrogeological modelling.	No direct influence. Indirectly, advection-induced changes in water composition may affect viscosity and density.	
Mechanical stresses	No direct influence. Indirectly, mechanical stresses may affect porosity, pore geometry, and initiate cracking, and therefore create preferential paths for water transport.	Indirect influence of mechanical stresses is handled under water transport in Sections 5.2.1 and 5.2.2.	No direct influence. Indirectly, advection-induced changes in the water composition may create stress fields through dissolution and precipitation reactions.	Indirect influence is considered in Section 5.4.6.
Material composition	No direct influence. Indirectly, the material composition affects advection by its influence on water composition.	Indirect influence of material composition through dissolution/precipitation reactions is handled in Section 5.4.6.	No direct influence. Indirect influence on material composition through advection-induced sorption, dissolution and recrystallisation.	Indirect influence considered in Sections 5.4.3, 5.4.4 and 5.4.6.
Water composition	Yes, water composition determines magnitude of advective transport of solutes. Indirectly, the density and viscosity of water may affect water transport through changes in hydraulic conductivity.	Dissolved concentrations is considered in solute transport calculations. Indirect influence is handled under water transport in Sections 5.2.1 and 5.2.2.	Yes, the water composition is influenced by advective transport of dissolved species, colloids, and particles, and by mixing of different waters. Indirectly also via dissolution/precipitation, see Section 5.4.6.	Advection-induced changes in water composition is included in solute transport modelling.
Gas variables	No direct influence. Indirectly the presence of gas may block conductive pores and displace pore water by gas.	Indirect influence is handled in Sections 5.2.1 and 5.2.3.	No direct influence. Indirectly, the advective transport of dissolved gases affects the gas phase composition via Henry's law.	Indirect influence is handled in Section 5.2.3.

Influence by hydrological variables

A direct influence has been identified.

Advective transport of solutes in the barriers is controlled by the magnitude, direction and distribution of water flow driven by pressure differences. Other hydrological variables have indirect influences on advection through the process of water transport, a process further described in Sections 5.2.1 and 5.2.2. These include: the water pressure distribution within the barrier that is a major control of the extent of water transport; changes in the aggregation state of the water which has an obvious influence on water transport, in that the water flow effectively stops upon freezing, e.g. during periglacial conditions. Water pressure may further affect the equilibrium position of dissolution reactions, thereby altering the dissolved concentrations and indirectly (through the variable water composition) the advective transport of dissolved species in the barrier.

Influence on hydrological variables

No direct influence has been identified.

Indirect effects due to advection-induced changes in the water composition that influence the physical properties of water are addressed in Section 5.2.1. Indirect effects due to advection-induced changes in the water composition that result in dissolution or precipitation, which may affect the amount of water and degree of saturation are addressed in Section 5.4.6.

Influence by mechanical stresses

No direct influence has been identified.

Mechanical stresses may result in changes in the porosity and pore geometry of any porous material through elastic compression and compaction. The importance of this depends on the strength and compaction of the material, the mechanical stress applied etc and may indirectly influence advective transport through the process of water transport (Sections 5.2.1 and 5.2.2).

Influence on mechanical stresses

No direct influence of advection and dispersion on the mechanical stresses in the concrete barriers, vaults and backfill materials in BMA has been identified. Indirectly, the advective transport of reactants present in the groundwater and in the waste may result in chemical reactions in the concrete barriers that may influence the stress field, see Section 5.4.6.

Influence by material composition

No direct influence has been identified.

The material composition of the barriers, including transient changes upon concrete degradation and corrosion of reinforcement steel rods, influences the porosity and pore geometry, which affect the extent of water transport (Section 5.2.1 and 5.2.2), and therefore has an indirect influence on advection. The material composition may also affect the extent of advective transport indirectly as a result of sorption (Section 5.4.3 and 5.4.4), dissolution, precipitation and recrystallisation reactions (Section 5.4.6), and the influence of these processes on the pore water concentrations.

Influence on material composition

No direct influence has been identified.

The material composition is indirectly affected by advection via sorption (Section 5.4.3 and 5.4.4), and dissolution, precipitation and recrystallisation reactions (Section 5.4.6) that may result from advection-induced changes in the water composition.

Influence by water composition

A direct influence has been identified.

The water composition has a direct influence by defining the magnitude of advective transport of the dissolved species. This influence is handled within SR-PSU by estimating appropriate pore water concentrations in solute transport calculations. Furthermore, the pore water salinity affects the density and viscosity of water and may therefore influence the advection and dispersion processes indirectly through water transport (Sections 5.2.1 and 5.2.2).

Influence on water composition

A direct influence has been identified.

The water composition is directly affected by the advective transport of dissolved species, colloids and particles, as well as by the mixing caused by dispersion effects. This is handled within SR-PSU

by including advection-induced changes of the water composition in solute transport modelling. Indirectly, advective transport of dissolved species may induce dissolution, precipitation and recrystallisation reactions (Section 5.4.6), which may influence the pore water composition.

Influence by gas variables

No direct influence has been identified.

The presence of gas in the pores of the barriers will influence advective transport indirectly by creating locally unsaturated conditions, changing the water flow pattern, displacing pore water, and limiting the accessible pore volume (see Section 5.2.1 for water transport under unsaturated conditions). The occurrence of any connected gas-filled porosity in the barriers would furthermore allow for transport of compounds in gas phase, described in Section 5.2.3.

Influence on gas variables

No direct influence has been identified.

The advective transport of dissolved gases will influence the gas composition and pressure indirectly by establishing equilibria between the gas and water phase.

Boundary conditions

The boundary conditions for the processes of advection and dispersion are the groundwater flow rates, the degree of water saturation and the groundwater chemical composition at the physical boundaries of the barrier and the waste form.

Model studies/experimental studies

There are several modelling studies evaluating the role of advection and dispersion processes within the SFR volume. These include radionuclide transport modelling (e.g. Lindgren et al. 2001, Thomson et al. 2008b, see further Section 5.5.2), models for solute transport involved in concrete degradation (e.g. Cronstrand 2007, Höglund 2001, see also Section 5.4.6), and modelling of the redox evolution (e.g. Duro et al. 2012, see also metal corrosion in Section 5.4.9). The advective transport models rely on assumed or modelled water flow rates.

Concrete plugs are present in the Äspö HRL, and have been examined with respect to water flow (SKB 2010b), which governs the extent of advective transport. Underlying hydrogeological modelling studies with relevance for the SFR barriers are further described in Sections 5.2.1 and 5.2.2.

Natural analogues/observations in nature

Natural analogues of advection and dispersion and observations of these processes in nature are common but are not considered here due to the detailed theoretical understanding of the process of advection and the simplified treatment of dispersion.

Time perspective

Advective transport by flowing groundwater will occur within, at least, some parts of SFR, over its lifetime. A gradual loss of barrier function is presumed, in particular as a result of freeze damaging during periglacial permafrost.

Handling in the safety assessment SR-PSU

Advective transport is a core consideration in the safety assessment of solute transport in all SFR compartments, including the BMA barriers. The process is incorporated in the governing equations used for radionuclide transport modelling and in concrete barrier degradation calculations.

A coarsely discretised compartment approach is applied in modelling, which implies a conservative estimate of dispersion. The numerical dispersion introduced by the relatively coarse discretisation of the barriers is greater than the expected physical dispersion.

Gas-driven advection processes are considered in scenario calculations (cf. SKB 2008b).

Handling of uncertainties in SR-PSU

Uncertainties in mechanistic understanding: Advection and dispersion processes can be considered mature science and the conceptual uncertainties are small.

Model simplification uncertainties: The model simplifications relate to the model representation of the complex geometries of the different concrete constructions and the inherent heterogeneities introduced by variations in material composition, the presence of numerous form rods, joints between construction elements, occurrence of fractures and the uncertainties related to the prediction of change of barrier properties in response to ongoing degradation processes over time. The assignment of boundary conditions to reflect the changes of groundwater chemical composition over time may introduce additional uncertainties.

Input data and data uncertainties: Uncertainties in input data are significant with respect to flow properties already at present day, in particular due to reported presence of fractures. These uncertainties are considered when assigning input data values in modelling. The sensitivity to input data is checked by parameter variations and scenario analysis.

Adequacy of references supporting the handling in SR-PSU

The references are judged to be adequate and sufficient to support the handling in SR-PSU. All supporting references are either peer-reviewed articles or documents which have undergone factual review. Other references have been used for general background information, and not all of these have been peer-reviewed to the same standard.

5.4.2 Diffusion

Overview/general description

Diffusion is an important process in the safety assessment of BMA, as it is deemed to be the key solute transport process in low water flow regimes. Diffusion will also be an important process affecting the long-term buffering of pH due to leaching of alkaline components in the concrete.

Diffusion of molecules

Gradients in solute concentration (or, more precisely, in chemical potential) result in the diffusion of dissolved molecules from higher to lower concentration regions. This process is driven by the Brownian motion of the molecules and is described by Fick's laws for single phase systems. Diffusion is species specific, and can therefore transport different species in different directions simultaneously. In saturated porous matrices, diffusion is slower than in a pure solution because the solid phase restricts molecular movement. The effective diffusivity (D_e ; m²/s) of a molecule therefore depends upon the diffusivity in free water (D_0 ; m²/s), the free space in the matrix, or porosity (ϵ ; m³/m³), the number of bottle necks along the free path, represented by the constrictivity factor (δ), and the path length through the porous medium in relation to the geometrical length, or tortuosity (τ), according to the following relationship:

$$D_e = D_0 \cdot \epsilon \cdot \delta / \tau^2 \quad (5-9)$$

The term δ / τ^2 is derived experimentally as one entity (Höglund 2001).

The heterogeneous pore and fracture structure of concrete results in the co-existence of different diffusional pathways through the concrete barrier. The greatest effective diffusivity is expected in any cracks or fractures and, in their absence, the larger pores. The on-going degradation of concrete (Section 5.4.6) will therefore affect diffusion. The granite or silica ballast in the concrete offers a negligible diffusion pathway, and this is a very significant component of the BMA construction concrete (Höglund 2001). Metal form rods used in the construction of the barriers are still present in the concrete. The concrete around these rods is presumably of higher initial porosity than the bulk concrete and, since the rods run through the concrete, this creates pathways of greater effective diffusivity (Höglund 2014). The combined effect of concrete degradation and metal corrosion will further increase the porosity (and diffusivity) in the concrete structures with time, which eventually may create advective flow paths (see Section 5.4.1). The large differences in porosity and pore geometry between the concrete barrier and sand/gravel backfill will lead to a step change in effective diffusivity for species migrating between the two matrices.

Diffusion of ions

The diffusion of ionic species is affected by ion–ion electrostatic interactions (e.g. Galíndez and Molinero 2010) and the condition of electroneutrality in the system. Surface–ion interactions can also affect diffusion through porous matrices such as bentonite clay (e.g. Ochs et al. 2001, SKB 2006) and cement/concrete (e.g. Zhang and Buenfield 1997, Chatterji 2004). Surface–ion effects occur in small pores with negatively charged surfaces, as found in highly alkaline concrete. Anion exclusion occurs when the pore size is so small that the cation-rich electric double layers (EDL) generated by the negatively charged pore surfaces (see Section 5.4.5 for a description of this) overlap and create a barrier to anionic species (SKB 2006). The converse of anion exclusion is enhanced cation diffusion, resulting from the relatively high dissolved cation concentrations generated in the EDL.

The extent of diffusive transport of ionic species is also affected by electro-osmotic effects that may arise from natural telluric currents or induced currents from electrical conductors. Of special interest in SFR are induced electrical currents during the operational period arising from the nuclear power plant in Forsmark and the high voltage direct current transmission cables Fenno-Skan 1 and 2. The influences of the Fenno-Skan cables on the safety functions are being investigated.

Dependencies between process and system component variables

Table 5-8 shows how the Diffusion processes in BMA influence, and is influenced by, all variables of the concrete barriers, the vault and backfill. In addition, the handling of each influence in SR-PSU is indicated in the table and more thoroughly discussed in the text below.

Influence by geometry

Yes, a direct influence has been identified.

Diffusion will be affected significantly by the geometric dimensions, porosity and pore characteristics of the barriers, as well as the frequency and size of fractures. The cross-sectional area affects the extent of diffusion, while the thickness of the barrier influences the diffusion path length, and the pore geometry influences the effective diffusivity of species. Narrow pores may also lead to surface–ion effects, i.e. anion exclusion and enhanced cation diffusion. Gradual degradation of the concrete barriers will influence the geometric parameters, which will in turn influence diffusion (see further discussion in Section 5.4.6).

Influence on geometry

No direct influence has been identified.

Diffusion will not have a direct effect on geometry. Indirect effects due to changes in the water composition and the resultant dissolution, precipitation and recrystallisation reactions are addressed in Section 5.4.6.

Table 5-8. Dependencies between the process Diffusion and the BMA system component variables.

Variable	Variable influence on process		Process influence on variable	
	Influence present? Yes/No Description	Handling of influence How/If not – Why	Influence present? Yes/No Description	Handling of influence How/If not – Why
Geometry	Yes, diffusion is proportional to barrier dimensions and significantly affected by pore geometry.	Included in the transport modelling.	No, only an indirect influence via diffusion-generated changes in water chemistry that affect dissolution and precipitation (Section 5.4.6).	See Section 5.4.6.
Temperature	Yes, temperature affects diffusivity.	Not considered due to the largely isothermal conditions of the BMA.	No, diffusion does not affect temperature.	
Hydrological variables	Yes, diffusion is affected by freezing.	Changes in effective diffusivity due to water freezing is included in the modelling.	No, but diffusion may indirectly affect freezing via its influence on water composition.	
Mechanical stresses	No, only an indirect influence via porosity and pore geometry, which affect the effective diffusivity of species.		No, only an indirect influence via diffusion-generated changes in water composition that affect dissolution and precipitation (Section 5.4.6).	
Material composition	No, only indirectly via pore geometry and water composition (See Sections 5.4.3, 5.4.4, 5.4.6 and 5.4.7).		No, only indirectly via water composition and the processes of dissolution, precipitation and recrystallisation (Section 5.4.6).	
Water composition	Yes, a major control of diffusion across the BMA barriers.	Included in the modelling.	Yes, affects the water composition through the movement of dissolved chemical species, colloids, particles and dissolved gases in stagnant systems.	Included in the modelling.
Gas variables	Yes, as gas can influence the accessible pore volume for diffusion of dissolved species and block diffusive pathways.	Considered in the modelling.	No, only indirectly via water composition since diffusion of dissolved gases will reduce their concentration at the source.	

Influence by temperature

Yes, a direct influence has been identified.

Higher temperatures increase the rate of diffusion due to increased Brownian motion. Temperature gradients may also induce changes in chemical potential, creating diffusional gradients (Lerman 1988). However, these effects are relatively small (SKB 2006). In SFR, the impact of thermal diffusion is judged to be negligible due to the practically isothermal conditions in the BMA repository, at any given time.

Influence on temperature

No direct influence has been identified.

Diffusion will not have any direct effect on temperature.

Influence by hydrological variables

Yes, a direct influence has been identified.

Diffusion is dependent on the concentration gradient and characteristics of the barriers and backfill, thus the only hydrovariable that directly affects diffusion is a change in aggregation state. The freezing of water during glaciation periods will clearly slow the rate of diffusion. However, other hydrological variables have indirect influences on diffusion via water composition. For example, the amount of water and degree of saturation affect the amount of solid material that dissolves and therefore the mass of species diffusing. Water pressure may affect the equilibrium position of dissolution reactions, in particular of gases, thereby altering the concentration gradients in the barriers. Also, the relative importance of diffusion depends on the water flow.

Influence on hydrological variables

No direct influence has been identified.

Diffusion will not affect hydrological variables directly. Indirect effects via water composition include the influence on the freezing point of water, and dissolution or precipitation reactions that affect the geometry and thus transport processes (Section 5.4.6).

Influence by mechanical stresses

No direct influence has been identified.

Mechanical stresses may influence diffusion indirectly by affecting the porosity and pore geometry of concrete and backfill materials through elastic compression and compaction. The degree of such impact may change over time due to degradation caused by dissolution, precipitation and recrystallisation (Section 5.4.6) and different external load scenarios, e.g. rock fallout (see the **Geosphere process report**) and the possible mechanical consequences for the barriers (see Section 5.3.1). Except for extreme scenarios the impact by mechanical stresses on diffusion is judged negligible.

Influence on mechanical stresses

No direct influence has been identified.

Diffusion will not affect mechanical stresses directly. Indirect effects are addressed in dissolution, precipitation and recrystallisation (Section 5.4.6).

Influence by material composition

No direct influence has been identified.

Material composition will have an indirect influence on diffusion, via the the porosity and the pore geometry of the barrier. The same applies to the backfill materials, although these are a lesser barrier to diffusion. Material composition will also affect diffusion via water composition as a result of sorption (Sections 5.4.3, 5.4.4 and 5.4.7), dissolution, precipitation and recrystallisation reactions (Section 5.4.6) and their influence on aqueous concentration gradients.

Influence on material composition

No direct influence has been identified.

Diffusion will only affect material composition indirectly due to dissolution, precipitation and recrystallisation reactions (Section 5.4.6) resulting from changes in the water composition.

Influence by water composition

Yes, a direct influence has been identified.

The water composition is a major control of diffusion across the BMA barriers. Diffusion will occur simultaneously in different directions for different dissolved chemical species, colloids, particles and dissolved gases, according to the individual concentration gradients. pH and Eh differences will determine the diffusion of protons, hydroxyl ions, and pH and Eh-controlled chemical species. The water composition will also influence the diffusivity of individual ionic species due to the constraints of electroneutrality and interdiffusion between the diffusing species. Diffusivity is also related to the viscosity of the solution, which in turn is controlled to a significant extent by the water composition.

Influence on water composition

Yes, a direct influence has been identified.

Diffusion affects the water composition through the movement of dissolved chemical species, colloids, particles and dissolved gases in stagnant systems. It also influences the pH, redox conditions, water density and viscosity along their respective gradients.

Influence by gas variables

Yes, a direct influence has been identified.

The presence of gas in the pore system of the BMA barriers will directly influence the accessible pore volume for diffusion of dissolved species and may block diffusive pathways. Gas variables will also have an indirect effect via water composition, since the amount, composition, volume, pressure and degree of saturation of gases in different parts of the repository may result in diffusive gradients.

Influence on gas variables

No direct influence has been identified.

Gas variables will have an indirect effect via water composition, since the diffusion of dissolved gases will reduce their concentration at the source, and allow further gas dissolution.

Boundary conditions

The boundaries of this analysis are the barriers themselves with exchange of mass with the waste/waste package and the surrounding geosphere considered.

Model studies/experimental studies

Höglund (2001) calculated the impact of dissolution and precipitation processes in the concrete barriers on porosity over a 10,000 year time period, and the changes in effective diffusivity of dissolved components. Three approaches were used, and two of these were relevant to the BMA. In these, the porosity of the concrete barrier only exceeded the 15% porosity suggested for performance assessment in one of the five model concrete cells for each case (19% and 17% porosity maximum respectively). Taking the barrier as whole, the effective diffusivity within the barrier would remain below the performance assessment value for the concrete with 15% porosity of $1 \cdot 10^{-11}$ m²/s, over the 10,000 year period modeled.

A more recent modelling study has highlighted that predictions of concrete evolution are sensitive to the equations used to define diffusion (Galíndez and Molinero 2010). The inclusion of ion-ion interactions, through Poisson-Nernst-Planck equations, alters the predicted concentrations of ions in the concrete porewater as a function of depth and time, compared to the predictions using Fick's laws. This affects when the porewater is predicted to be supersaturated with respect to different solid phases and thus, the patterns of predicted mineral precipitation. Galíndez and Molinero (2010) found that Fick's laws predicted lower sulphate and Ca²⁺ concentrations in cement matrix porewater as a result of sodium sulphate diffusion into concrete than predicted by Poisson-Nernst-Planck equations.

This meant that while gypsum (CaSO_4) precipitation was predicted using Poisson–Nernst–Planck equations, it was not predicted using Fick’s laws. The results of the modelling were not validated directly by experimental data, but through acceptable agreement with the output of a different model, STADIUM, involving the same ion–ion interactions (Marchand et al. 2002) that has been validated by experimental data (e.g. Maltais et al. 2004).

- Gaucher et al. (2005) modelled with PHAST the chemical evolution of SILO repository near-field. They considered only diffusive transport of radionuclides and did sensitivity studies considering different diffusion coefficients.
- Cronstrand (2007) modelled with PHREEQC the evolution of a barrier of concrete (BMA and SILO). Diffusion was the only radionuclide transport considered. Deformation processes due to precipitation and dissolution of minerals or to freeze and formation of fractures and cracks were modelled by a set of models in which diffusion coefficients change with time.
- Thomson et al. (2008a) presented a model, using AMBER, of the near field of each part of the SFR repository and for different scenarios (SILO, BMA, 1BTF, 2BTF and BLA). Both advection within the waste and from the waste to the geosphere and diffusion were considered in the calculations.
- Diffusion is a process described in SKB (1999a, b) and in Höglund (2001).
- Several experimental studies are available in the scientific literature describing diffusion of solutes through cementitious materials.

Natural analogues/observations in nature

Diffusion is difficult to study in natural analogue sites because key factors such as the original inputs and conditions are not well defined.

There are several natural analogue studies focused on diffusion of radionuclides. However most of them (if not all) are dealing with diffusion in the geosphere (matrix diffusion specially). Such natural analogues include Cigar Lake, Poços de Caldas, El Berrocal, Maqarin, among others. There are no natural analogues for diffusion in concrete barriers.

Time perspective

Diffusion is anticipated to be the dominant transport mechanism across the concrete barrier prior to major fracturing events, i.e. glaciation. The diffusivity of species within the barrier will change as the concrete evolves, altering the porosity and pore characteristics of the barrier and the gradients of dissolved chemical species against the changing groundwater conditions.

Handling in the safety assessment SR-PSU

Diffusion will be a core consideration in the safety assessment for the BMA. Depending on the groundwater flow conditions at different times, advection or diffusion may be the predominant transport process. In SAR 08 (SKB 2008b) a limited advective transport was defined as a safety function of the BMA concrete barriers. It was presumed that the concrete barriers would not be expected to be affected by fractures in a way that would degrade their long-term function of limiting advective transport in the repository until affected by freezing due to permafrost. Considering recent observations of the occurrence of fractures in the BMA concrete barriers a more pessimistic approach is necessary. The presence of fractures may shorten the diffusion paths and enhance the transport rate of both radionuclides through the concrete barriers (see Section 5.5.2) and the leaching of macro components in the concrete (see Section 5.4.6) and is considered in the modelling.

Handling of uncertainties in SR-PSU

Uncertainties in mechanistic understanding: Diffusion processes in general can be considered mature science and the conceptual uncertainties are small.

Model simplification uncertainties: The model simplifications relate to the model representation of the complex geometries of the different concrete constructions and the inherent heterogeneities introduced by variations in material composition, the presence of numerous form rods, joints between construction elements, occurrence of fractures and the uncertainties related to the prediction of change of barrier properties in response to ongoing degradation processes over time.

Also, diffusion transport is modelled using Fick's law to describe the transport of multi-component ionic species. Therefore, the suitability of Fick's law should be checked against more precise mechanistic descriptions, e.g. ion–ion interactions using the Poisson–Nernst–Planck equations.

The assignment of boundary conditions to reflect the changes of groundwater chemical composition over time may introduce additional uncertainties.

Input data and data uncertainties: Uncertainties in input data are significant with respect to transport properties already at present day, in particular due to reported presence of fractures. Uncertainties in input data and data uncertainties are handled by assigning pessimistic values. The sensitivity to input data is checked by parameter variations and scenario analysis.

Adequacy of references supporting the handling in SR-PSU

The references are judged to be adequate and sufficient to support the handling in SR-PSU. All supporting references are either peer-reviewed articles or documents which have undergone factual review. Other references have been used for general background information, and not all of these have been peer-reviewed to the same standard.

5.4.3 Sorption on concrete/shotcrete

BMA includes two different materials where sorption may be relevant:

- Concrete/shotcrete in the barrier and vault;
- crushed rock in the backfill.

Sorption processes in these materials differ significantly from each other. In order to get a better overview, both are treated separately in the following.

Overview/general description

Introduction

The present section addresses the sorption of radionuclides and relevant main elements on concrete and shotcrete in the BMA barrier and vault. Because of the properties of the cement matrix (see below), it can be assumed that the chemical behaviour of both systems will be dominated by the matrix. Therefore, concrete and shotcrete are treated together in the following. Note also that this process is described in detail in the **Waste process report**. There, the sorption of each radionuclide is discussed, addressing also the influence of organic ligands (such as complexing agents and isosaccharinic acid, ISA) on the process. For the present barrier process report, an abbreviated version of the material discussed in the **Waste process report** is given.

In the context of other barrier materials (clays, crushed rock), the term 'sorption' is used exclusively in the sense of surface adsorption, where solute–surface interaction can typically be described by the relatively well-defined processes of ion exchange and surface complexation, cf. Section 3.5 in SKB (2010a).

Due to the nature of hydrated cement paste (HCP), the range of interactions involving dissolved species and solid phase is much broader. In the present context, the meaning of sorption is therefore not restricted to surface adsorption, but is taken to additionally encompass a number of other uptake processes, including incorporation processes.

The cement matrix of concrete consists of hydrated cement paste (HCP). This material has several unique features which provide the framework for sorption processes:

- A distinctive feature of hydrated cement is its evolution with time (or more specifically, its degradation as a function of the amount of percolating water). Typically, this evolution can be described in terms of more or less distinct degradation stages (see also Section 5.4.6). With respect to sorption, it is important to note that the overall reactivity and the sorption properties of HCP are not constant.
- HCP is a mixture of several mineral phases with distinctively different sorption properties. An overview of the relevant HCP mineral phases is given in the next section.
- The majority of these minerals is not well crystallised and has a high bulk reactivity. These minerals are subject to continuous compositional changes and related structural rearrangements.

The solid phase

The major cement solid phases (by mass) in HCP are amorphous CSH (Calcium-Silicate-Hydrates) and crystalline portlandite (Ca(OH)_2). Minor phases include ettringite (aluminoferrite trisulphate, AFt), monosulphate (aluminoferrite monosulphate, AFm), hydrogarnet and hydrotalcite, which are also crystalline. Calcite may form during HCP evolution.

In concrete or shotcrete, quartz sand and gravel derived from crystalline rock provide additional minerals, such as quartz, feldspars, and mica. To a first approximation, it can be assumed, however, that sorption of most radionuclides in mortar and concrete is mainly related to HCP.

HCP has a high specific surface area; typically $> 50 \text{ m}^2/\text{g}$. The large surface area is mainly associated with CSH phases, which are reported to have a specific surface area of about $150\text{--}450 \text{ m}^2/\text{g}$ (Taylor 1990, Glasser 1993, Tits et al. 2006). In comparison, the crystalline phases have a much smaller surface area (e.g. about $6 \text{ m}^2/\text{g}$ for portlandite).

With respect to sorption processes, the main minerals in HCP are the nearly amorphous CSH phases and the crystalline aluminates:

- **CSH phases.** They are the main hydration product of cement clinker, possess a very low crystallinity (gel-like, nearly X-ray amorphous), and a high sorption capacity. The CSH mineral structure resembles corrugated layers of alternating CaOH and silicate units, organised in platelets with maximum dimensions $< 100 \text{ nm}$. The platelets strongly adhere to each other, forming a poorly organised, nanoporous bulk gel. The low crystallinity and imperfact structure of CSH give rise to a high density of sorption sites (Glasser 1993) and does not allow to distinguish in any fundamental way between surface adsorption and bulk-incorporation processes.

CSH also have a variable composition. The Ca/Si molar ratio (C/S) can vary from about 1.6 to 0.83. The amount and proportion of various sorption sites (internal and external), and therefore the sorption behaviour, is dependent on the C/S ratio, which controls the availability of Ca. The C/S ratio also influences the surface charge (zeta potential) of CSH phases, which is positive at $C/S > 1.2$ and negative at lower C/S. The positive surface charge mainly results from sorption of Ca ions. Note that in whole HCP the zeta-potential becomes negative again at higher C/S ratios due to the lower Ca-solubility caused by the high pH in the presence of alkalis (Pointeau et al. 2006).

Sorption on CSH can occur through a number of processes, which have been elucidated in a few cases only, however (see also following section). Surface sorption can take place by surface complexation on Si–OH groups and/or a type of ion exchange (replacing Ca). In addition, different types of incorporation processes seem to be relevant.

- **Aluminosulphates.** Depending on the availability of sulphate and the temperature during hardening of cement paste and further evolution of HCP, ettringite (AFt) or monosulphate (AFm) may form (cf. Taylor 1990). Ettringite is more common, forming when enough sulphate is available and at ambient temperature, and consists of Ca-aluminate columns with sulphate located in the channels between the columns. Sorption typically occurs by replacement of sulphate by other anions and also by replacement of Ca and Al in the columns.

Monosulphate formation is favoured by sulphate-limiting conditions and elevated temperatures. It has a similar composition but different structure than ettringite, with Ca-aluminate platelets and sulphate located in the interlayer. Like ettringite, monosulphate favours crystallochemical substitution reactions.

- **Hydrogarnet** and **hydrotalcite** are Ca- and Mg-aluminates, respectively, and are minor components of HCP. Sorption occurs most likely as crystallochemical substitution reactions in both cases.
- **Portlandite** ($\text{Ca}(\text{OH})_2$) is an important constituent of fresh (unleached) HCP. In highly degraded HCP, **brucite** ($\text{Mg}(\text{OH})_2$) may be relevant. Both minerals are thought to play a minor role for sorption.
- **Calcite** may form during HCP evolution or be present as part of the aggregate material. Sorption typically takes place through substitutions (cf. Curti 1997).

Overview of sorption processes

The state of knowledge regarding the various sorption processes is generally very much tied to a specific radionuclide. The state of the art in terms of process understanding is clearly variable: in case of some radionuclides, sorption processes are understood in detail, but there are other cases where the sorption processes are not identified at all. At the same time, the sorption of some elements proceeds by more than one mechanism while other elements are taken up through very specific sorption processes which are relevant for a particular group of elements only.

Because of this situation it is difficult and not very meaningful to treat sorption processes in HCP in a generalised way. On the other hand, a certain system understanding (e.g. of changes in the magnitude of sorption as a function of pH) can be demonstrated in many cases even where the actual sorption process is not known. A brief overview given below, a detailed description for each radionuclide is provided in the **Waste process report**.

In summary, the following sorption processes in HCP-systems can be identified:

- Of major importance are incorporation processes into amorphous CSH phases. These processes resemble the formation of solid solutions, but are not necessarily stoichiometric, due to the poorly structured nature and the resulting flexibility of CSH in incorporating hydroxides between the silicate layers. Co-precipitation with CSH phases may also occur following their alteration.
- In particular the CSH phases also give rise to actual sorption reactions, such as ion exchange with the Ca^{2+} ions of the CaOH layers and surface complexation with exposed Si in the silicate sheets.
- The formation of classical solid-solution phases involving the more crystalline aluminate minerals and calcite, where mineral constituents are replaced stoichiometrically with trace elements.
- Some trace elements are taken up by HCP through the formation of new solubility-limiting solids as a result of interaction with HCP. As these solubility-limiting solids only form in the presence of certain hydrated cement minerals and not from homogeneous solution, this process can be considered as sorption as defined for the present context.
- In case of concrete or mortar, the same processes as for HCP are relevant; in addition, there may be sorption by the aggregate material (mainly relevant in case of radionuclides involved in ion exchange; i.e. alkali and alkali earth elements).
- As discussed in detail in the **Waste process report**, the sorption of radionuclides in the cement-based components of SFR may be influenced by the presence of organic complexing agents that may stem from the waste or concrete/grout formulations.

In addition to these sorption (in the wider sense) processes, the actual mechanism for retention in case of some radionuclides will be isotopic exchange (e.g. with a corresponding stable isotope as constituent of a cement mineral phase). In this context, it is important to note that HCP contains a wide range of trace elements, some at levels that are at or near the respective solubility limits.

The present section discusses the sorption of both radionuclides and relevant main elements. The process descriptions are restricted to discussing the effect on the fate of the radionuclides and other elements. The effect of such processes on the properties of the cement phases themselves is discussed in a separate process (Section 5.4.6).

Dependencies between processes and barrier variables

Table 5-9 summarises how the process Sorption (shotcrete and concrete) influences and is influenced by all BMA variables. In addition, the handling of each influence in SR-PSU is indicated in the table and more thoroughly discussed in the text below.

Table 5-9. Direct dependencies between the process ‘sorption’ (shotcrete and concrete) and system component variables and a short note on the handling in SR-PSU.

Variable	Variable influence on process		Process influence on variable	
	Influence present? Yes/No	Description	Influence present? Yes/No	Description
Geometry	No.	Sorption is a molecular-level chemical process which is not directly influenced by macroscopic geometry.	No.	See row material composition.
Temperature	Yes.	Temperature will have an effect on solids composition and on sorption processes.	No.	–
Hydrological variables (pressure and flows)	No.	No direct influence on sorption.	No, but indirectly through affecting material composition and geometry (Incorporation of major ions in HCP may cause mineral expansion and alter flowpaths).	See material composition.
Mechanical stresses	No.	–	No, but indirectly, see hydrological variables.	–
Material composition	Yes.	The composition of the material influences its sorption properties.	Yes.	Incorporation of major ions in HCP may cause mineral alteration.
Water composition	Yes.	Water composition can directly affect sorption and influence mineralogy.	Yes.	Incorporation of major ions and radionuclides in HCP influences dissolved concentrations.
Gas variables	No direct influence.	CO ₂ can influence sorption indirectly through effects on water composition and mineralogy. H ₂ and CH ₄ can influence sorption indirectly through creating reducing conditions (water composition).	Included in K _d where relevant.	No direct influence. Indirectly through influencing dissolved concentrations (especially Ca). No significant effects expected.

Barrier geometry. Indirect geometry is influenced since sorption (incorporation) of main elements or ions in HCP structure can lead to mineral expansion and cracking. This concerns mostly processes that occur in the presence of relatively high concentrations of chloride, sulphate and carbonate.

Temperature can influence sorption processes in several ways. First, temperature can have a direct effect on sorption processes such as ion exchange, surface complexation, and solid solution formation and affect sorption also indirectly through influencing water composition. Second, the stability of the various HCP mineral phases is a function of temperature, and a change in temperature may influence mineralogy (material composition) and therefore indirectly sorption. While the influence of temperature on sorption and also on mineralogy in the complex HCP system is not known, it is assumed that chemical effects will be dominating in comparison to temperature, based on the high reactivity of HCP. Furthermore, no large temperature variations are expected at SFR.

Hydrological variables (pressure and flows): Incorporation of major ions present at relatively high concentrations in HCP minerals (and precipitation from homogeneous solution) may lead to volume increase and cracking or clogging of pores, thus altering flow (and diffusion) pathways indirectly via material composition and geometry. On the other hand, hydrological variables are not expected to have a direct influence on sorption. An indirect influence via flow-induced changes in porewater composition is also not likely, as the porewater composition is well buffered.

Mechanical stresses: The volume taken up by certain mineral fractions may be influenced, see hydrological variables. No influence on sorption is expected

Material composition: Sorption is dependent on composition of HCP and possibly on aggregate composition. Composition of HCP is in part determined by clinker composition and grout/concrete formulation (including organic concrete admixtures), in part by mineral alteration and degradation through contact with groundwater. Mineral alteration resulting from the incorporation of ground-water ions can be seen as a form of sorption.

Water composition can have an important direct as well as an indirect influence on sorption. While the pore solution in HCP is well buffered with respect to pH and the concentration of some typical groundwater constituents, elevated levels of anions such as chloride or sulphate will lead to elevated levels in the pore solution as well. Similarly, the presence of organic ligands that may stem from the waste or from the cementitious materials will influence radionuclide sorption. Whether the presence of inorganic or organic solutes will have a significant effect on sorption depends on the sorption process and needs to be evaluated for each sorbing element (or group of elements). The presence of reducing agents like H_2 and CH_4 will influence the oxidation state and therefore the speciation and sorption behavior of redox-sensitive elements. Additionally, sorption may be influenced through affecting the oxidation state of other solutes. Water composition has also an indirect influence on sorption by affecting cement degradation and the resulting mineral composition of HCP. Most of the solid-liquid equilibria important for water composition can be handled by using thermodynamic equilibrium models. On the other hand, the dissolved concentration of trace constituents, such as radionuclides, in the porewater will be influenced by sorption.

Gas variables: No direct influence is expected. Indirectly, CO_2 can influence the mineralogy of HCP, which could affect sorption properties. However, this is probably not important in comparison to the mineral alteration by degradation through water. On the other hand, sorption processes are part of the suite of chemical reactions that influence the corresponding equilibrium gas composition, but their influence is presumably not significant. Changes in pressure of CO_2 should also have no influence because the dissolved carbonate concentration is controlled by solubility equilibrium with calcite or other solids. On the other hand, H_2 and CH_4 can influence sorption indirectly through creating reducing conditions.

Boundary conditions

Boundary conditions concerning sorption within the waste matrix and concrete packaging are:

- Those of the transport processes that control the exchange of solutes between the surrounding water and the waste/packaging compartments; i.e. those of the processes diffusion and advection/dispersion.
- All boundary conditions relevant for the processes related to cement/concrete degradation (see Section 5.4.6, as these will partly determine the properties of the sorbing solid).

Further boundary conditions include the radionuclide concentration and distribution in the waste, as well as the temperature.

Model studies/experimental studies (including time perspective)

As pointed out in the introduction, sorption processes in HCP can vary significantly among different groups of elements/radionuclides. Similarly, process understanding is closely related to a specific element or group of elements. Therefore, the various sorption processes are best discussed directly in the context of the uptake of relevant radionuclides or main elements. A detailed description is given in the **Waste process report** and is not repeated here.

Natural analogues/observations in nature

Analogue studies are available regarding cement degradation, including attack by specific ions (chloride..., cf. Lagerblad and Trägårdh 1994, Smellie 1998). Regarding sorption of radionuclides, strong retention of trace elements in cementitious systems (such as landfills, solidified wastes) has been demonstrated (Glasser 1993). Observations in such systems do typically not correspond to sorption, because the trace elements are added to the cementitious material during setting, but still support the notion of generally high sorption.

Handling in the safety assessment SR-PSU

Before saturation, the process is neglected.

After saturation: radionuclide sorption is included in the modelling of radionuclide transport. Sorption is quantified using K_d values that are specific for each element (and oxidation state, where relevant) as well as for each identified cement degradation state. The presence of organic ligands is taken into account in the evaluation of K_d values through element-specific reduction factors (which implicitly also account for the sorption of organics, see the corresponding **Data report**). The effects of major ion interaction with HCP are included in the assessment of cement evolution/degradation (Section 5.4.6).

Handling of uncertainties in SR-PSU

Uncertainties in mechanistic understanding.

As pointed out in the introduction, the level of understanding sorption varies very much among different radionuclides. Therefore, uncertainties are discussed together with sorption processes for specific elements (or groups of elements) in the section on model studies/experimental studies in the **Waste process report**. Uncertainties are reflected in the choice of bounding K_d values.

Model simplifications uncertainties

Quantification of sorption is based on the simple concept of constant K_d . K_d is a highly conditional parameter, which is strictly valid only for the specific set of conditions that it has been derived for. The actual uncertainties of K_d for a given set of conditions can be estimated. Because hydrated cement systems are well buffered, it should also be possible to sufficiently constrain the conditions. At the same time, the simple K_d concept is based on reversibility of sorption. In view of the various incorporation processes relevant for sorption on HCP and of the continuous changes that the solid HCP is undergoing, reversibility can clearly not be assumed.

Input data and data uncertainties

For the radionuclides, input data are K_d values that can be used directly in consequence calculations. Uncertainties of these K_d values can be estimated for a given set of conditions and degradation states. The sorption behaviour of major elements is not addressed explicitly, but is included in the assessment of cement degradation (see Section 5.4.6).

5.4.4 Sorption on crushed rock backfill

Overview/general description

Radionuclides and major ions in water moving through the backfill can be bound to the surfaces of the crushed rock material in several ways (see below). These processes are henceforth summarised under the term sorption and can affect the mobility of most radionuclides and major ions.

In gravel obtained from (freshly) crushed crystalline rock, the principal (primary or rock-forming) minerals offering surfaces relevant for sorption are typically micas. In comparison, the other major primary minerals in typical crystalline rock (quartz and feldspars) have a significantly smaller specific surface area and/or a lower concentration of relevant surface sites per unit mass. The importance of micas, and especially of biotite containing high amounts of structural Fe(II), has been confirmed experimentally for the sorption of various radionuclides on fresh granitic rock and weathered fracture surfaces (e.g. Kienzler et al. 2009, Koskinen et al. 1988). In highly altered or weathered material, clays, iron (hydr)oxides and other infill minerals may become more important. Generalisations regarding the sorption properties of such material are difficult, as they can depend strongly on the specific alteration/weathering history. Upon exposure of the fresh surfaces to water, further surfaces of secondary minerals may be created as a result of weathering, such as clay minerals from feldspars or, under non-reducing conditions, Fe(III)-hydroxides from Fe in the crystal lattice of different primary minerals. Under reducing conditions, Fe(II/III) minerals (magnetite) or Fe(II) phases, such as siderite, may form. In weathered material, sorption may be dominated by the secondary minerals.

The principle type of surfaces offered by these minerals and the respective possible sorption reactions (surface complexation, ion exchange) are for the most part the same as in case of bentonite, described in Section 7.4.3. In particular mica may be viewed (from the point of sorption processes) as a non-expandable 2:1 clay mineral with a smaller specific surface area and CEC, but allowing the same type of sorption processes (surface complexation/ligand exchange at edge AlOH and SiOH functional groups, ion exchange at external siloxane surfaces with permanent charge). Some weathering products (weathered micas and illite) possess frayed edge sites (FES, cf. Sposito 1984) that show a particular high affinity for Cs and bind this element (partly) irreversibly. The surfaces of possibly present Fe(III)-hydroxides and -oxides are similar to the edge surfaces of clays, but the exposed FeOH-groups typically show a higher affinity for many metal ions and reactive anions than clay edge surface groups (Dzombak and Morel 1990). Further, hydrous forms of these minerals may (partly) re-crystallise over time, which can lead to the (irreversible) incorporation of adsorbed species. Because Fe is a redox-sensitive element, adsorbed species may also undergo redox reactions on these surfaces.

Dependencies between processes and barrier variables

Table 5-10 summarises how the process Sorption (crushed rock) influences and is influenced by all BMA variables. In addition, the handling of each influence in SR-PSU is indicated in the table and more thoroughly discussed in the text below.

Barrier geometry. Crushed rock consists nearly exclusively of well crystallised minerals whose volume and geometry are not influenced by ions sorbed to their surfaces.

Temperature can directly affect sorption processes. This is generally acknowledged, but trends of sorption as a function of temperature are not understood to date. Further, temperature can indirectly affect sorption by influencing aqueous speciation. In lack of information to the contrary, it is assumed that chemical effects will be dominating in comparison to temperature (also, only small variations in temperature are expected).

Hydrological variables (pressure and flows) Hydrological variables are not expected to have a direct influence on sorption, or to be influenced (see geometry above).

Mechanical stresses: No influences are expected (see also geometry above).

Material composition: Sorption is dependent on the mineralogy of the crushed rock, especially on secondary mineral coatings that may be present or develop over time. On the other hand, no significant influence by sorption is expected (coatings are expected to be mainly controlled by precipitation/dissolution, see Section 5.4.6 and water composition).

Table 5-10. Direct dependencies between the process ‘sorption’ (crushed rock) and system component variables and a short note on the handling in SR-PSU.

Variable	Variable influence on process		Process influence on variable	
	Influence present? Yes/No Description	Handling of influence How/If not – Why	Influence present? Yes/ No Description	Handling of influence How/If not – Why
Geometry	No. Sorption is a molecular-level chemical process which is not directly influenced by macroscopic geometry.	–	No. The geometry of the crystalline minerals in crushed rock does not depend on sorbed ions.	–
Temperature	Yes. Temperature will have an effect on sorption processes.	No. Influence of temperature on sorption must be expected, but trend and magnitude are not clear. Where sorption data for relevant temperatures are available, they are taken into account in the selection of RN K_d values.	No.	–
Hydrological variables (pressure and flows)	No. No direct influence on sorption.	–	No, see geometry.	–
Mechanical stresses	No.	–	No, see geometry.	–
Material composition	Yes. The composition of the material influences its sorption properties.	Included in selected K_d where relevant.	No. The bulk composition of the minerals in crushed rock does not depend on sorbed ions.	–
Water composition	Yes. Water composition can affect sorption.	Included in K_d where relevant.	Yes. Sorption of trace ions could influence dissolved concentration.	Dissolved radionuclide concentration calculated via K_d . Not considered for main constituents: effect regarded as negligible in comparison to mineral solubility.
Gas variables	No direct influence. CO_2 , H_2 and CH_4 can influence sorption indirectly through aqueous speciation/water composition.	Included in K_d where relevant.	No direct influence. Indirectly through influencing dissolved concentrations. No significant effects expected.	Not considered.

Water composition can have an important direct influence on sorption, as well as an indirect influence through mineral precipitation/dissolution. Of particular importance in this context may be mineral alterations by highly alkaline fluids. Elevated levels of certain groundwater constituents (such as chloride or sulphate) or of organic ligands stemming from the waste or from concrete formulations may also affect sorption. The effect of water composition on sorption generally depends on the sorption process and needs to be evaluated for each sorbing element (or group of elements).

Gas variables: This is considered negligible due to control of dissolved carbonate by solubility equilibrium with calcite or other solids in the cement-based parts of the barrier. On the other hand, H_2 and CH_4 can influence sorption indirectly through creating reducing conditions (influencing water composition). The influence of sorption processes on solution chemistry and the corresponding gas equilibria is considered insignificant.

Boundary conditions

Relevant boundary conditions are those that control the transport of solutes to and from the component; i.e. the boundary conditions of the processes advection and diffusion.

Model studies/experimental studies

Ion exchange as well as surface complexation are well-established processes and their relation to sorption on the different surfaces available on crushed rock has been discussed above. In principle, the model and experimental studies described for clay in Section 7.4.3 are also relevant for crushed rock surfaces. Especially surface complexation and ion exchange on oxides and clays has been studied extensively and thermodynamic sorption models for a range of simplified systems have been developed; see e.g. the literature cited in Stumm and Morgan (1996) and Schindler and Stumm (1987).

There is also a considerable amount of experimental sorption data for crushed crystalline rock material (Crawford et al. 2006, Crawford 2010). However, due to the heterogeneity of crystalline rock and the difficulties in identifying the relevant surfaces, comparatively few systematic studies have been carried out which would allow an elucidation of the detailed sorption reactions (NEA 2012). Arnold et al. (2001) analysed sorption of U(IV) onto phyllite rock and onto the individual mineral components. They also developed and tested thermodynamic sorption models and showed the potential importance of including secondary minerals, such as oxides.

Natural analogues/observations in nature

Long-term studies of sorptive/diffusive transport have been carried out in the Äspö laboratory, see e.g. Widestrand et al. (2010). Various well-researched examples also exist regarding the interaction of radionuclides and major ions with unconsolidated, weathered rock (Davis et al. 2002, 2003). These examples show that sorption determined in batch experiments is applicable to larger scales and that it is dominated by and strongly dependent on the nature of the particular weathering products and on the composition of the contacting groundwater.

Time perspective

Sorption of radionuclides is considered for the entire assessment period. An ion exchange process in itself is normally very fast, so with respect to the distribution of major cations, the rates of other processes (dissolution/formation of minerals, transport of dissolved species) will control any apparent time dependency. Surface complexation, which is the main sorption process for most radionuclides (see above and Section 7.4.3) is a slower process than ion exchange; it may need hours to tens of days to reach full equilibrium in terms of sorption/desorption. However, sorption can be expected to be largely completed within a day. The timescales that are of interest are thus dependent on the travel time of water through the crushed rock layer. In the absence of very large hydraulic gradients, the timescales of sorption can therefore be assumed to be not relevant.

Handling in the safety assessment SR-PSU

Before saturation, the process is neglected. After saturation: radionuclide sorption is included in the modelling of radionuclide transport. Sorption is quantified using K_d values that are specific for each element (and oxidation state, where relevant) as well as for the respective conditions (material and water composition). Process uncertainties can generally be expressed through the use of bounding K_d values. The exchange behaviour of major elements is not addressed explicitly.

Handling of uncertainties in SR-PSU

Uncertainties in mechanistic understanding

There are no major uncertainties in the understanding of the sorption processes as such. Of the primary minerals relevant for crushed crystalline rock, mainly mica is important for sorption (NEA 2012). Sorption processes (ion exchange, surface complexation) on mica are essentially the same as on smectite. Sorption on oxide minerals occurs in nearly all cases via surface complexation and is well understood.

In case of weathered material, sorption will depend on the composition of the secondary weathering products, and the main uncertainty is related to characterisation of the minerals assemblage and the possible interaction of the various mineral surfaces. Depending on the minerals present, solid solution formation may also be relevant.

There are major uncertainties regarding the application of experimental data obtained in disperse systems to intact rock (NEA 2012). However, these are largely related to hydraulic issues (e.g. fraction of flow-wetted surface, accessible fissures etc).

Model simplifications uncertainties

Quantification of sorption is based on the concept of constant K_d . Because of the strong dependency of the discussed sorption processes on various chemical parameters, K_d values are strictly valid only for the specific set of conditions that they have been derived for. For a given set of conditions, the uncertainties of K_d can be estimated. On the other hand, under variable geochemical conditions, overall uncertainty in K_d is easily dominated by the uncertainty in conditions. For the crushed rock part of the barrier it can be assumed that chemical conditions are to a large part dominated by the adjacent cement mass and therefore fairly well constrained.

The simple K_d concept is also assuming reversibility of sorption. For the surface adsorption processes occurring on crushed fresh crystalline rock, the assumption of reversibility is reasonable. In case of amorphous secondary weathering or alteration products, reversibility cannot be assumed a priori.

Input data and data uncertainties

Input data are K_d values for radionuclides that can be used directly in consequence calculations. Uncertainties of these K_d values can be estimated for defined geochemical conditions.

5.4.5 Colloid stability, transport and filtering

Overview/general description

The term colloidal refers to a state of subdivision, in which molecules or polymolecular particles dispersed in a medium have at least one dimension between 1 nm and 1 μm (IUPAC 2011), and they can be inorganic or organic in nature. Their small size is important for two reasons: 1) colloids can be transported through many fractured or porous media, and 2) colloids have very high surface area to mass ratios. The high surface area to mass ratio gives the colloidal form of a material a much higher sorption capacity per unit mass than the bulk material. Therefore, relatively low concentrations of colloids can compete effectively with the solid phase for contaminant sorption and enhance contaminant transport. The transport of radionuclides is treated in Section 5.5. This present section will focus on the stability, mobility and filtration of colloids within the BMA barriers. Processes leading to formation of cementitious and oxyhydroxide colloids from concrete dissolution and corrosion of steel reinforcement are described elsewhere; see e.g. Section 3.5.4 in the **Waste process report**. The processes of concrete dissolution and steel corrosion in the BMA barriers are described in Sections 5.4.6 and 5.4.9, respectively. Finally, colloids may form as a result of physical erosion of solid materials (concrete, gravel and sand).

Stable colloids in the waste and groundwater may enter the BMA barriers. The **Waste process report** describes four types of colloids that may be generated from the wastes: organic colloids from chemical and microbial degradation of organic materials, cementitious colloids, iron oxyhydroxide colloids resulting from steel corrosion, and radionuclide eigencolloids. Bitumen is of particular interest as a potential source of mobile organic colloids as it is an aggregated colloidal material itself. The groundwater contains naturally occurring inorganic colloids and humic substances. Laaksoharju et al. (1995) reported a median colloid content in saline and non-saline granitic groundwaters at 5 different sites in Sweden (in the depth range 50–1,600 metres) of 20 and 45 $\mu\text{g/L}$ respectively (saline water min = 2 $\mu\text{g/L}$, max = 3,000 $\mu\text{g/L}$), dominated by metal oxyhydroxides, silicate and clay mineral colloids.

Despite the wide range of possible colloids in the BMA, their stability and persistence in the barriers depends on the extent to which they remain as dispersed entities and avoid aggregation to the point of sedimentation or attachment to available surfaces, under the prevailing chemical conditions. Repulsive forces are therefore required between individual colloids and these are controlled by a number of factors including the pH, ionic strength and colloid density in solution. Colloids may also be removed from a system when chemical properties change (e.g. change in redox conditions) inducing degradation reactions that cause them to break down into their component molecules.

pH. The charge of most particle surfaces changes significantly with pH, and each mineral has a characteristic pH at which it has zero charge (pzc). As the pH increases above the pzc, the surface charge becomes increasingly negative through deprotonation and/or hydroxide ion association with surface sites. Most naturally occurring colloids possess a negative surface charge at pH 7 (van Loon and Duffy 2000), and all surfaces of interest would be expected to be negatively charged under the highly alkaline conditions of the SFR cement leachates. This is expected to enhance inter-colloid repulsion.

Humic acids and analogous colloids are large, branched organic macromolecules with acidic functional groups in their structures. When these acid groups are deprotonated, the negative charges enhance the polarity of the humic acid, and thus its solubility in water (Keepax et al. 2002).

Ionic strength. Dissolved ions can also interact with colloid surfaces and affect the surface charge and colloid stability. The main mechanisms are electrostatic adsorption (reversible ion-exchange process) and specific adsorption (covalent chemical bonding) onto surface binding sites (van Loon and Duffy 2000). Colloids are particularly unstable in the presence of divalent ions such as Ca^{2+} and Mg^{2+} .

However, ionic strength also affects the stability of colloids through changes to the electric double layer surrounding the colloid. Close to the colloid, dissolved ions of opposite charge to the colloid surface (counter ions) experience electrostatic attraction, while those of the same charge experience repulsion. This generates a solution phase “layer” around the colloid with a predominance of counter ions (e.g. van Loon and Duffy 2000). A higher ionic strength results in a higher density of counter ions around the colloid, thus the surface potential is lowered over a shorter distance and the thickness of the electric double layer is reduced. This, in turn, lowers the repulsive forces between colloids and leads to aggregation. The critical coagulation concentration (CCC) is the total cation concentration that results in diffusion-controlled aggregation of colloids, which results in rapid sedimentation.

For humic acids and analogous organic colloids, a high ionic strength also results in lower solubility, with neutralisation of the intramolecular repulsions as counterions associate with the acid functional groups. This can lead to contraction, aggregation and precipitation (Keepax et al. 2002).

Quantification of colloid stability. The Derjaguin–Landau–Verwey–Overbeek (DLVO) theory calculates colloid stability by summing the attractive van der Waals forces between colloids and the electrostatic repulsion generated by the electrical double layer at the colloid surfaces. Colloids aggregate when the attractive forces dominate, and are stable and remain dispersed in solution when repulsive forces dominate. The temperature affects the electrostatic repulsion in a complex manner according to the DLVO theory (García-García et al. 2009). Under temperate conditions, temperature variations in SFR are expected to be small, and thus this effect is negligible. Freezing may affect colloids under periglacial permafrost conditions. It is difficult to quantify these effects due to their complex and colloid-specific temperature dependence, although freezing generally leads to colloid aggregation (see e.g. Rowell and Dillon 1972).

Colloid stability within the BMA barriers. The SR-Site Buffer, backfill and closure process report (SKB 2010a) considered that water with a cation content higher than 2–4 mM charge equivalents prevents montmorillonite colloidal sol formation under the pH conditions of the spent fuel repository, provided that the calcium content in the montmorillonite is above 20%. In Wold (2010) it was found that groundwaters with an ionic strength > 0.1 M (with $\text{Ca}^{2+} > 10^{-4}$ M) consistently had natural colloid concentrations below 100 µg/L. The ionic strength and divalent ion concentration of the current groundwater are above these values and although a future low salinity groundwater is likely to have a low ionic strength, the divalent ion concentrations (see Section 5.4.7) may still reduce colloid stability. Equally, colloid concentrations in cementitious systems during both alkali metal and portlandite leaching phases have been found to be below 100 µg/L (Wieland and Spieler 2001, Wieland et al. 2004).

Changes in pH affect the stability of colloids, their interactions with surfaces and their release during dissolution of host phases (Laaksoharju et al. 1995). Therefore, pH changes in the barrier porewater over time as a result of cement evolution (Section 5.4.6) or mixing with lower pH waters originating from the surrounding rock may result in further dissolution or precipitation reactions and may also affect colloid stability.

Colloid transport and filtering. Stable colloids in the BMA may be transported with the flowing groundwater through fractures and pores in the barriers. The extent of transport depends on both the flow rate and the physical properties of the flow path and colloids, which determine the extent to which colloids are filtered out of solution. The main mechanisms of filtration are “pore straining attachment” when the colloids are too large to pass through the apertures, and “grain attachment” when colloids attach to solid surfaces through for example electrostatic, van der Waals, physical or hydrophobic interactions. Another relevant process is “ripening”, an increase in pore surface roughness resulting from colloid deposition that increases the likelihood of further colloid deposition. Therefore, the width distribution of the pores, the presence and size distribution of other particles and the surface roughness of the pores affect the extent of colloid filtration. The dependency of overall transport on colloid size is complex due to dispersion effects (Wold 2010). However, dispersivity effects in the BMA barriers are likely to be minor and neglected in hydrogeological models as discussed in Section 5.4.1.

Filtration processes may be reversible, and transport of reversibly attached colloids depends on the relative rates of attachment and detachment. These rates are affected by changes in chemical or hydraulic conditions, and sudden changes have been found to mobilise a pulse of colloids in several studies (Laaksoharju et al. 1995, and references therein), however it was found that the large increase in dispersed colloid concentration was temporary.

In an unsaturated system, additional processes can contribute to colloid interactions with pore surfaces. Limited water present in thin films over the solid phase can limit the ability of the colloid to move into the solution phase and gas bubble formation across a flow path can block colloid migration. However, colloids may also attach to gas bubbles through hydrophobic interactions and be transported by flotation. Due to the highly complex colloid-pore interactions, the simplified DLVO theory has been found to be non-sufficient to satisfactorily describe the retention or filtration of colloids along a flow path (Smith and Degueldre 1993).

Dependencies between process and system component variables

Table 5-11 provides a summary of how the process of colloid transport and filtering is influenced by a specified set of physical variables and how the process influences the variables. In addition, the handling of each influence in SR-PSU is indicated in the table and more thoroughly discussed in the text below.

Influence by geometry

A direct influence has been identified.

The porosity and pore characteristics of the barriers, as well as the presence of any fractures have an important influence on the colloid filtration capacity. Dynamic processes such as concrete degradation and corrosion of steel reinforcements and form rods are expected to result in increased permeability in the long term. Colloid filtration is however not handled explicitly in the safety assessment, as both theory and experimental data suggest that colloid stability is low under cementitious conditions.

Influence on geometry

A direct influence has been identified.

Colloid filtration can affect the porosity and pore characteristics of the barriers as colloids may associate with the solid phase increasing surface roughness (ripening) and eventually block flow paths. This influence is not handled explicitly, although variations in porosity and pore characteristics of the barriers are included in the hydrogeological modelling.

Influence by temperature

A direct influence has been identified.

Temperature has an influence on colloid stability according to the DLVO theory. However, this influence is neglected due to the very small temperature variations expected during temperate conditions.

Table 5-11. Dependencies between the process of “colloid transport and filtering” and the system component variables, and a short note on the handling in SR-PSU.

Variable	Variable influence on process		Process influence on variable	
	Influence present? Yes/No Description	Handling of influence How/If not – Why	Influence present? Yes/No Description	Handling of influence How/If not – Why
Geometry	Yes, colloid filtering is influenced by the aperture width of connected voids, surface roughness, and transport path length.	Not handled explicitly as both theory and experimental data suggest that colloid stability is low under cementitious conditions.	Yes, deposited colloids may alter porosity and pore characteristics such as surface roughness.	Not handled explicitly, although this is covered by the variations in barrier porosity and pore characteristics included in the hydrogeological modelling.
Temperature	Yes, colloid stability is influenced by the temperature.	Not handled explicitly, as the temperature variations in BMA are negligible.	No direct influence.	–
Hydrological variables	Yes, water flow rate and degree of saturation as well as the aggregation state of water have influence on the transport and filtering of colloids.	Not handled explicitly as both theory and experimental data suggest that colloid stability is low under cementitious conditions.	No direct influence. However, deposition of colloids may have an indirect influence on flow rates via geometry (porosity and pore characteristics).	–
Mechanical stresses	No direct influence. However, mechanical stresses may have an indirect effect via geometry, through alterations to the porosity and pore characteristics as well as induction/closure of fractures.	–	No direct influence.	–
Material composition	Yes, amount, composition and surface characteristics, e.g. surface charge have influence on interaction with colloid surfaces.	Not handled explicitly as both theory and experimental data suggest that colloid stability is low under cementitious conditions.	Yes, the composition and characteristics of the exposed barrier material surfaces may become altered by deposited colloids.	Not handled explicitly, although variations in barrier material composition and surface characteristics are included in case studies.
Water composition	Yes, ionic strength and pH affect colloid stability. The concentration of colloids and particles also influences colloid stability and retention.	Influence is taken into consideration when evaluating colloid stability by DLVO theory, and is a major factor in the judgement that colloids have a low stability under cementitious conditions.	Yes, the process influences the concentration of mobile colloids and any dissolved species with an affinity to sorb to these colloids.	Not handled explicitly as both theory and experimental data suggest that colloid stability is low under cementitious conditions.
Gas variables	Yes, hydrophobic interaction may lead to colloids associating and transported with gas bubbles. Indirectly, the presence of gas influence water flow.	Not handled explicitly, as colloid stability is judged to be suppressed to a large extent under the expected conditions.	No direct influence.	–

Influence on temperature

No direct influence has been identified.

Colloid filtration is unlikely to generate or consume heat.

Influence by hydrological variables

A direct influence has been identified.

Hydrological variables will control the direction and magnitude of advective colloid transport, e.g. following degradation of the barriers. The degree of saturation and amount of water will affect colloid transport and filtering. Limited amount of water would result in fewer mobile colloids, as

their stability is a function of colloid density, water chemistry and surface interactions. High pressure gradients may decrease colloid collision with solid surfaces and the filtering effect in the pores and fractures. These influences are not handled explicitly, as both theory and experimental data suggest that colloid stability is low under cementitious conditions. The aggregation state of water is important as colloids may become immobilised in ice or frozen out, as described for salts and humic substances in Section 5.4.7.

Influence on hydrological variables

No direct influence has been identified.

However, colloid filtration can lead to an increase in surface roughness (ripening) and eventually pore blocking, thus limits the porosity of flow pathways indirectly (see influence on geometry).

Influence by mechanical stresses

No direct influence has been identified.

However, mechanical stresses affect colloid transport and filtering indirectly via changes in the geometry, due to compression of the pore space of the barrier, or through the induction or closure of fractures.

Influence on mechanical stresses

No direct influence has been identified.

Influence by material composition

A direct influence has been identified.

Colloid filtration is affected by the amount, composition and surface characteristics of the materials used in the barriers as these factors will affect the extent to which colloids interact with the surfaces. This influence is not handled explicitly, as both theory and experimental data suggest that colloid stability is low under cementitious conditions.

Influence on material composition

A direct influence has been identified.

Colloid filtration can affect the composition and surface characteristics of the materials used in the barriers as their exposed surface may become coated by deposited colloidal material. This influence is not handled explicitly, although variations in barrier material composition and surface characteristics are considered.

Influence by water composition

A direct influence has been identified.

The water composition plays a critical role in colloid transport as the ionic strength, pH, and type and amount of colloids and particles are crucial factors in colloid stability and filtration. This influence is taken into consideration when evaluating colloid stability by DLVO theory, and is the reason behind the judgement that colloids have a low stability under cementitious conditions. Water composition may also influence the tendency for colloids to break down into their component molecules, i.e. the chemical stability of colloidal precipitates.

Influence on water composition

A direct influence has been identified.

The stability, transport and filtration of colloids affects the type and amount of colloids remaining in the water phase. This in turn affects the density and viscosity of the water phase. However, as colloid concentrations are expected to be low, the impact on density and viscosity are judged negligible.

The transport and filtration also affect the dissolved radionuclide content of the water phase, through sorption of radionuclides to the colloid surface (Section 5.5.2). These influences are not handled explicitly, as both theory and experimental data suggest that colloid stability is low under cementitious conditions.

Influence by gas variables

A direct influence has been identified.

Gases can affect colloid transport and filtration as colloids can become trapped in a flow path when a gas bubble blocks the path, or alternatively a colloid can be transported associated with the surface of a gas bubble by hydrophobic interaction (flotation). Therefore, the magnitude, direction and distribution of gas flow may have an influence on colloid transport. This influence is neglected, as both theory and experimental data suggest that colloid stability is low under cementitious conditions.

Influence on gas variables

No direct influence has been identified.

Boundary conditions

The boundary conditions for the processes of colloid stability, transport and filtration are the water flow rates, degree of water saturation, and the water composition (e.g. pH, ionic strength and colloid concentration) at the physical boundaries of the barrier to the waste form and to the surrounding geosphere.

Model studies/experimental studies

Many studies exploring colloid stability and transport have focused on bentonite colloids because of the application of bentonite backfilling commonly proposed for spent fuel and high level waste repositories. See the SR-Site Buffer, backfill and closure process report (SKB 2010a) for a description of these studies, as bentonite is used as backfill in the Silo in SFR. Here, we focus on studies of cementitious colloids.

In Wieland and Spieler (2001) the presence of 50–1,000 nm size colloids was examined in a highly permeable mortar foreseen as the backfill in the Swiss repository for low and intermediate waste. The Ca^{2+} and Na^+ concentrations of the cement matrix porewater were characteristic of the Portlandite phase, with 20 mM Ca^{2+} and 3 mM Na^+ , thus the pH was ~ 12.5 . The experiments demonstrated that under these high Ca^{2+} concentrations, colloid concentrations were below ~ 0.1 ppm. Linear extrapolation of the colloid size distribution suggested that colloids in the 1–50 nm fraction dominated the number distribution and comprised up to 20% of the colloidal mass, despite their small individual masses. The specific (geometric) surface area of the colloids over the 1–1,000 nm size range was estimated to be between 240–770 $\text{m}^2 \text{g}^{-1}$ or, excluding the extrapolated fraction (see discussion below), the 50–1,000 nm colloids had a specific surface area of 15–26 $\text{m}^2 \text{g}^{-1}$.

In Fujita et al. (2003) colloids released from a High Flyash and Silica fume-content Cement was examined as a function of the solid:liquid ratio (1:5, 1:50 and 1:100), leaching time (2 and 8 months) and temperature (20 and 60°C). This cement does not generate Portlandite, and so the porewater is buffered to pH ~ 11 and the Ca^{2+} concentrations are lower than those associated with Portlandite leaching. The leaching time did not affect the colloid population significantly, and the dominant colloids were spheroidal in shape and composed of Ca, Si and Al. The solid to liquid ratio had a significant effect on the type and distribution of colloids. The lowest colloid concentrations and largest colloids were found in the high solid:liquid ratio experiments, which are most representative of a repository environment. The colloid concentration in this high solid:liquid system was estimated to have an upper limit of $6.3 \cdot 10^{10}$ colloids per litre with a mean particle size of 200 nm. The observation of the colloid size distribution by Transmission Electron Microscopy (TEM) challenged the linear extrapolation used by Wieland and Spieler (2001), as 1–50 nm colloids were present and important but did not dominate the distribution. Importantly, the colloid concentrations obtained

experimentally in Wieland and Spieler (2001) for the 50–1,000 nm fraction were consistent with the TEM data (Fujita et al. 2003), thus the experimental data were in agreement. In Fujita et al. (2003) it was found that composition of colloids in the high solid:liquid ratio systems was quite variable in terms of ratios of Ca, Si and Al, although the low solid:liquid ratio systems contained colloids with a similar composition to the bulk cement hydrate. They also found slightly lower colloid concentrations with slightly larger mean colloid sizes at 60°C. There was little change in the size distribution of the colloids when they were exposed to $< 2 \cdot 10^{-4}$ M Ca^{2+} for 24 hours, while fast coagulation was seen with $\text{Ca}^{2+} > 5 \cdot 10^{-4}$ M. DVLO theory showed a potential barrier to coagulation at Ca^{2+} concentrations below $5 \cdot 10^{-4}$ M, consistent with the experimental results.

In Wieland et al. (2004) the release and limited stability of CSH colloids during an initial stage of cement degradation was demonstrated, i.e. in a system dominated by Na (0.1 M) and K (0.2 M) release, at pH 13.3. These experiments support an upper colloid concentration of 0.1 mg/L in the highly alkaline porewater of the Swiss backfill mortar. It should be noted that physical changes, such as the end to end shaking used by Wieland et al. (2004) generate colloid release, thus the colloids remaining in solution once the system relaxes are most relevant to the BMA (Laaksoharju et al. 1995).

Colloidal transport and filtering are challenging to model, and no models have been published on colloid transport and filtration through concrete barriers to our knowledge. Colloid transport through fractured rock has been modelled, but this required detailed experimental data for each step of the development process (Smith and Degueudre 1993). The model showed that the colloid-wall interaction was of critical importance, and this parameter needs to be quantified experimentally. In an ongoing Grimsel Colloid Formation and Migration (CFM) project conducted at the Grimsel Test Site, bentonite erosion is studied on metre to field scales. The purpose is to investigate the influence of colloids on radionuclide migration in a fractured host rock under advective flow conditions at repository relevant conditions.

Natural analogues/observations in nature

The Maqarin site in Jordan contains natural, aged alkaline minerals, resembling cement, thus provides a natural analogue site for the hyperalkaline cementitious repository environment. There is only a limited amount of colloid data available from this site due to technical difficulties in avoiding artifacts (i.e. colloid formation) when sampling. However, Wetton et al. (1998) report on a successful campaign sampling colloids through either a 30 or 50 nm size filter. They determined that the colloid number concentrations were $\sim 2 \cdot 10^{10} \text{ L}^{-1}$, which is consistent with the experimental studies discussed above. The small amount of material collected meant that the origin of the colloids was difficult to assess, although they made a tentative conclusion that the colloids could have originated from the cement phases.

Other observations in nature also support low colloid abundances at elevated ionic strengths, for example, the low concentrations of colloids and humic substances in current, saline Forsmark groundwater (see the **Geosphere process report**). However, the groundwater at the SFR site has not been characterised in terms of dissolved organic carbon or humic acid content, and there has been limited analysis of colloids in groundwater sampled from the depth of SFR.

Time perspective

Periods with different chemical and hydrological characteristics with possible influence on colloid transport and filtration in the BMA barriers are listed below. This list indicates general characteristics of relevance for colloid stability and transport only. For a detailed description of conditions (e.g. pH, ionic strengths, and divalent cation concentrations) deemed to be plausible for different time periods, see the **Data report**.

- An early period immediately following repository closure during which resaturation by groundwater occurs. The process of resaturation implies hydraulic gradients directing the groundwater flow from the surrounding rock into the different repository parts, with negligible transport of colloids out from the barriers. Furthermore, this period is expected to be of short duration and is therefore deemed to be of negligible importance for colloid transport and filtration.

- A salt water period following the early period. The SFR facility is located below sea bottom. Groundwater conditions have been restored; characterised by low natural hydraulic gradients, temperatures governed by the surrounding rock, the groundwater composition is expected to persist according to the present day observations in the SFR area. The high ionic strength of salt water and the likely cementitious conditions are expected to result in low colloid stability, according to DLVO theory.
- A period characterised by effects due to a possible shoreline displacement which results in changed groundwater flow and composition. Changes in hydraulic conditions alter the boundary conditions at the rock/barrier interface which may have some influence on transport and filtration of colloidal particles in the barriers. However, these changes occur slowly and no pulse release of immobilised colloids is expected. Therefore, this slow transient is deemed to have a negligible effect on the transport and filtration of colloids. Also, the ambient groundwater ionic strength may be expected to be somewhat lower compared to the salt water period described above, see also Section 5.4.7. The ionic strength in the pore water of the barriers is however judged to not be sufficiently affected to stabilise the colloidal particles.
- A period characterised by ongoing degradation of the concrete barriers in the repository which will change the barrier properties and affect the water chemistry. During this period, the pore characteristics are expected to change slowly with an increased barrier porosity and permeability leading to an increased transport of stable colloids. However, the change in pH and ionic strength is deemed to be insufficient to have a large impact on the stability and transport of colloids within the barriers.
- An inland period during which the local groundwater system has reached a steady-state situation that is controlled by the local topography with a mainly horizontal flow pattern. The groundwater in the vicinity of the repository is fresh, thus the ionic strength in the ambient groundwater would be expected to be lower during this time period. By this point, either cement minerals will still be present in the barrier, resulting in low colloid stability, or the barrier will have lost its retention capacity, and colloid stability could be high.
- A period with permafrost which will presumably lead to severe degradation of the concrete barriers. Although the permeability of the barriers is expected to be increased to a large extent during this period due to e.g. freeze cracking, the transport of colloids by groundwater is negligible under persistent frozen conditions.
- Periods with glaciation and glacial melt water situations, which presumably will lead to major changes in groundwater flow and composition. The ionic strength in the ambient groundwater is expected to be significantly lower during this period. The extent of barrier degradation is unknown and therefore it is not possible to quantify the ability of the concrete to maintain a high ionic strength within the barriers safely. Colloids are therefore cautiously assumed to be stable under ambient glacial melt water conditions. Due to presumably severely degraded state of the concrete barrier, the filtration of colloidal particles within the barriers is neglected. Additionally, some mobile colloids previously retained through pore straining within the barrier may be released during this period due to the large changes in hydraulic conditions expected.
- A long-term period, extending throughout the 100,000 year assessment time and characterised by varying conditions in the bedrock caused by long-term climate and other environmental variations including periods of glacial climate. The extent to which the barrier material has become degraded is unknown. The stability of colloids will depend on the local ionic strength and pH in this period.

Handling in the safety assessment SR-PSU

Low concentrations of colloids are expected under cementitious conditions in the BMA barriers and hence the influence of colloids on radionuclide transport has been neglected in the main scenario. Although it is not assessed or explicitly accounted for in the radionuclide transport modelling, the concrete barriers possess an inherent colloid filtration capacity. The barriers therefore provide a physical and electrostatic barrier restricting the transport of any colloidal particles present, and therefore further support this handling.

During time periods with an ambient groundwater composition dominated by glacial melt water, the ionic strength in the presumably severely degraded BMA barriers is much more uncertain, and the colloidal phases can not safely be assumed to be unstable and immobilised. For such conditions the processes of colloid transport is assessed indirectly in the residual scenario analyses associated with a loss of barrier function in the near field (SKB 2008b).

Handling of uncertainties in SR-PSU

Uncertainties in mechanistic understanding: The concept of low colloidal stability under high ionic strength, high Ca^{2+} conditions is well understood for a number of important colloid types, including cementitious colloids. However, there are uncertainties in extrapolating this relationship to all colloids present. Relatively little is known about the behaviour of natural groundwater colloids in a cementitious environment. Groundwater colloids are heterogenous and include humic acids, which are known to be less prone to aggregation at high ionic strength. Uncertainties regarding the stability of bitumen colloids, discussed in the **Waste process report** are also relevant here.

For many colloids, the uncertainties are relatively low when the cement in BMA is in equilibrium with portlandite. There is greater uncertainty in assuming negligible colloid concentrations for the longer time frames, when the ground water chemistry and state of the repository are less well known. This is handled through scenario analysis.

Model simplification uncertainties: Not applicable since colloid transport and filtration are not modelled.

Input data and data uncertainties: The main source of uncertainties in the evaluation of colloid stability used to negate the influence of colloids will come from the wide range of potential colloids in the BMA, their amount, size distribution and interactions with the solid phases.

Additionally, the water at the depth of SFR and in its immediate vicinity has not been characterised with respect to colloids. This means that there is uncertainty in assessing their ambient concentrations as low.

Adequacy of references supporting the handling in SR-PSU

The references are judged to be adequate and sufficient to support the handling in SR-PSU. All supporting references are either peer-reviewed articles or documents which have undergone factual review. Other references have been used for general background information, and not all of these have been peer-reviewed to the same standard.

5.4.6 Concrete degradation

Overview/general description

Concrete degradation may occur as a result of different chemical processes such as dissolution, precipitation and recrystallisation. These processes may occur as a result of interactions between the concrete barrier materials, the groundwater, the waste and the host rock. In addition to the chemical degradation processes treated in this section, also different mechanical processes can affect the integrity of the concrete barriers; these are treated in Section 5.3.1 (Mechanical processes).

The degradation of the concrete barriers includes leaching of soluble chemical components gradually leading to depletion of the binding components. As a result, the mechanical strength of the concrete will decrease. Leaching may also dissolve solid components that may increase the porosity and lead to increased diffusivity and increased hydraulic conductivity in the concrete barriers. The leaching will also preferentially lead to depletion of the most alkaline components of the concrete, which results in a gradual reduction of the pH in the repository. This may affect the retention of radionuclides in the barriers. Other chemical processes may occur due to interactions with certain chemical components in the groundwater or in the waste, e.g. sulphate that can result in transformation of cement mineral assembly, potentially leading to fracture formation. Occurrence of fractures would significantly reduce the ability of the concrete barriers to supply the desired safety function as a hydraulic barrier.

This process description focuses on the degradation of concrete barriers in the BMA vault. However, where appropriate and necessary, other components of the sub-system vault and backfill are also included. In many aspects the processes are similar to those occurring in the concrete packaging and cement waste matrix, as described in the **Waste process report**. Since many of the fundamental processes of degradation in the concrete barriers, i.e. dissolution, precipitation and recrystallisation, are also similar to those occurring in the concrete plugs studied for the SR-Site, essential parts of the descriptions have been extracted, and when required modified, from the SR-Site Buffer, backfill and closure process report (SKB 2010a). Dissolution, precipitation and recrystallisation reactions are of great importance, as they affect the hydraulic and chemical properties of the cementitious barriers. These reactions therefore affect the safety functions of the BMA barriers over time.

Dissolution–Precipitation

Dissolution occurs when a solid chemical compound is undersaturated with respect to the solution it is in contact with. Congruent dissolution implies the stoichiometric transfer of the solid components into the aqueous phase. Incongruent dissolution means a dissolution process where one of the solid phase chemical components is preferentially dissolved and released, followed by a corresponding change in the solid phase composition. Dissolution can continue as long as any mass of the solid phase remains and the solubility limit of the solution is not reached. Precipitation occurs when a solution becomes supersaturated with respect to a solid phase. Precipitation removes dissolved species from solution to form a solid phase. Precipitation can continue as long as the solution remains supersaturated.

Colloids are more likely to form in solutions that are strongly supersaturated, as there is a strong driving force for nucleation in addition to the on-going growth of existing crystals. Such situations may occur at mixing points where steep chemical gradients are found, e.g. at the interface between the alkaline conditions of cementitious waste systems and the groundwater of the geosphere. This may have relevance for the sub-system vault and backfill, as this may contain such mixing points. For further treatment of colloid stability and transport, see Section 5.4.5.

Recrystallisation

During recrystallisation, the structure of a precipitated compound gradually becomes more ordered, i.e. achieves a higher degree of crystallinity, while maintaining the same chemical composition. The driving force for recrystallisation is the higher thermodynamic stability (lower solubility) of more crystalline structures. The general tendency in a static chemical system, i.e. in a system with invariant ambient conditions, is therefore to form compounds of increasing crystallinity over time.

Recrystallisation follows precipitation because kinetic factors have an impact on the compounds that are precipitated. The interfacial free energy (solid mineral – solution) is higher for more crystalline phases, which have a lower solubility, of a certain mineral. Hence, according to the Ostwald step rule (see e.g. Stumm 1992), kinetics will favour precipitation of the least supersaturated compounds from the pore water solution, thereby creating a solid phase that may be metastable compared to more crystalline phases. According to the Ostwald principle, the recrystallisation processes may therefore proceed in many small steps, which over time results in increased crystallinity, interfacial free energy and size of crystals. The same principle applies also to colloids. For further treatment of colloid stability and transport, see see Section 5.4.5.

Recrystallisation processes may be of importance for understanding the long-term properties of e.g. CSH-gels in concrete. Recrystallisation may have an impact on the pore geometry since the very fine-structured amorphous and/or microcrystalline tobermorite-like and jennite-like mineral phases may gradually change in shape. The pore geometry may have a significant impact on the hydraulic conductivity and the diffusivity.

Conditions for processes to occur

The rate and extent of dissolution and precipitation processes in the concrete barriers is influenced by:

- The rate of advective water transport carrying dissolved species (see Section 5.4.1).
- The rate of diffusive transport of dissolved species (see Section 5.4.2).
- The composition of the concrete barriers including the assembly of hydrated cement clinker minerals.
- Any changes in the chemical composition of the concrete barriers induced by chemical reactions with surrounding rock/groundwater, waste packaging, porewater or conditioned waste. This may in turn influence the microstructure of the concrete which would affect its transport properties.
- The composition of concrete barrier pore water. This is in turn determined by local thermodynamic equilibria between the pore water and the solid hydrated cement minerals.
- Kinetic factors causing metastable equilibria, steady-state conditions, or slow establishment of equilibria.
- The composition of the groundwater and the pore water of adjacent materials (rock minerals, waste packaging, waste material).

Concrete barriers

Concrete consists of hydrated cement clinker minerals mixed with different filler and ballast materials such as sand and gravel. Steel reinforcement bars and form rods used during construction are embedded in the concrete.

The concrete is manufactured from unhydrated cement, sand, gravel and possible additives. Water is added to initiate the hydration of the cement clinker minerals which leads to hardening of the concrete, as described below. For certain purposes, different additives can be used in concrete, e.g. to improve flow properties and workability of the freshly mixed concrete slurry. In some cases significant amounts of filler materials such as slag or fly ash are added to change the mechanical or chemical properties of the concrete.

Construction concrete mixtures commonly contain a fairly high proportion of cement, about 350 kg/m³ cement and 165 kg/m³ of water. Details on the actual composition of the concrete barriers in the SFR repository are presented in the **Data report**.

Composition of cement clinker minerals

The unhydrated cement clinker minerals are formed during manufacture of the cement at high temperature in cement kilns. Typical unhydrated cement clinker minerals³ and components are:

- Tricalcium silicate, C_3S .
- Dicalcium silicate, C_2S .
- Tricalcium aluminate, C_3A .
- Tetra-calcium aluminate ferrite, C_4AF .
- Calcium sulphate (gypsum), $C\hat{s}H_2$ (*added as a retardant to the cement*).
- Alkali hydroxides, $N + K$.

Details on the actual composition of cement clinker minerals used for manufacture of the cement waste matrices in the SFR repository are presented in the **Data report**.

Hydration processes in cement

The unhydrated cement clinker minerals are highly reactive in contact with water. Hydration is the process by which the anhydrous cement clinker minerals react with water and form new (hydrated) solid compounds that give the cement its mechanical strength. The amount of water added to the cement will influence the properties of the hardened cement. A good comprehension of the cement hydration processes is an essential starting point for the description of dissolution/precipitation/recrystallisation processes and is highlighted in the following.

³ Abbreviations commonly used in cement science for the clinker components:

$C = CaO$, $S = SiO_2$, $A = Al_2O_3$, $F = Fe_2O_3$, $H = H_2O$, $C\hat{s}H_2 = CaSO_4 \cdot 2H_2O$, $N = Na_2O$, $K = K_2O$

The relationship between the water and cement added to the concrete mixture is termed the w/c-ratio. Since water is consumed during hydration, at low w/c-ratio (less than about 0.3) the cement clinker minerals will not be completely hydrated due to a lack of water. At high w/c-ratios, the water remaining after full hydration has occurred will contribute to an increased porosity. In general terms, a low w/c-ratio would give denser and mechanically stronger concrete than cement with a high w/c-ratio. The choice of mixing proportions is, however, a compromise between factors such as: high strength, desire to reach full hydration, workability of the fresh concrete, special demands on the permeability etc. Commonly, a w/c-ratio between 0.3 and 0.6 is used for normal construction work. The w/c-ratio used for construction concrete in SFR is about 0.47, which would be expected to yield full hydration and fairly low porosity.

The main binding phases of hydrated cement are calcium silicate hydrates (CSH) and calcium hydroxide (CH). In addition, two other major hydration products are produced from reactions involving calcium aluminate, calcium alumino-ferrite, and calcium sulphate, which are complex calcium sulpho ferri-aluminates⁴ known as AF_t and AF_m (Höglund 1992).

The hydrated cement minerals are alkaline and will maintain a high pH in the concrete pore water. The interstitial solution of an ordinary Portland-cement-based concrete will reach chemical equilibrium with the cement constituents, resulting in a hyperalkaline porewater (pH around 13) with high concentrations of alkaline Na⁺, K⁺, Ca²⁺ and OH⁻ ions, see the **Data report**.

The hydrated minerals are fairly soluble in comparison with many rock forming silicate minerals, which means that they are more susceptible to dissolution and degradation. The contact of the alkaline concrete porewater with dilute groundwater (pH lower than 9) at the exterior of the repository creates large concentration gradients which induce diffusive mass transport (of mainly Na⁺, K⁺, Ca²⁺ and OH⁻ ions) outwards from the porous concrete. The diffusion process is described in Section 5.4.2. Initially, the concrete barriers will protect the waste packaging and the cement waste matrices from the direct influence of groundwater as the groundwater passes through the barriers first. However over time this buffering capacity will be depleted and the concrete barriers will to some extent be influenced by the leaching and transport of soluble cement minerals from the waste packaging and cement waste matrices. Inflow of ambient groundwater by advection will gradually drive away the concrete porewater components and enhance the diffusion of ions and the degradation of cement, see Sections 5.4.1 and 5.4.2. However, in many cases the dissolution of one mineral may result in the precipitation of another. The high pH created by dissolution of the hydrated cement minerals in the concrete may also increase the reactivity of other minerals present in the concrete (e.g. ballast, filler materials or other additives), in the waste packaging, waste or host rock.

During the initial stage of cement degradation, the pore water will be dominated by alkali metal hydroxides (composed of K⁺, Na⁺ and OH⁻ ions) which give hyperalkaline conditions with a pH of about 13. Generally, the alkali metal hydroxides are soluble, and would therefore be easily leached from the concrete. Studies of the composition of concrete solid phases and pore water show, however, that the leaching of alkali metal hydroxides is retarded due to some type of chemical interaction with the solid phases, likely the CSH-gel phases or the ballast (Lagerblad and Trägårdh 1994). Leaching of alkali metal hydroxides ions will therefore decrease gradually, rather than in a stepwise manner, and the pH will decrease and the solubility of the calcium hydroxide (portlandite) and of then the CSH-gel will increase gradually in response to this. When the cement is characterised by portlandite leaching, the pH is buffered to 12.5. This is followed by a gradually lowering of the pH to about 10 as incongruent leaching of CSH-gel occurs (SKB 2008b). As a result, the C/S-ratio of the CSH-gel gradually decreases due to leaching.

The durability of cement is affected by the decalcification process, since calcium is the main component of hydrated cement. The continuous outwards diffusion of dissolved calcium alters the original chemical equilibrium, and induces dissolution of calcium compounds to restore chemical equilibrium. The dissolution of calcium hydroxide (portlandite) and CSH-gels leads to an increase in the porosity of the concrete, which at the same time enhances the diffusion rate and the hydraulic conductivity. Loss of calcium also reduces the mechanical strength.

The dissolution of CSH-gels needs special consideration. The reason is that the CSH-gels will preferentially leach calcium, leading to an incongruent dissolution of the gels. This has the effect that the remaining gels will become gradually enriched in silica. Simplified, this can be seen as

⁴AF_t = C₆(A,F)X₃H_y, and AF_m = C₄(A,F)XH_y, where X = CaSO₄; y = 32 for ettringite and y = 12 for monosulphate.

a dissolution/ precipitation reaction where a calcium-rich phase is dissolved directly followed by the precipitation of a new phase with slightly lower calcium content. A more correct conceptualisation may be that calcium is released from the CSH-gel into solution followed by a rearrangement of the partly calcium-depleted solid silicate phase. Experimental evidence shows an increased length of the silicate anion chains in leached CSH-gels (Haga et al. 2002). The solubility of the CSH-gel is complex due to its amorphous to semicrystalline structure, which might be described in terms of a mixture of tobermorite- and jennite-like phases (Chen et al. 2004). Detailed investigations have shown that CSH-gels have a large variability in their composition, nanostructure and morphology (Richardson 2004). Significant efforts have been made to understand the processes and structure of CSH-gels formed during cement hydration. Different attempts have been made to determine the relationship between solid phase composition and the composition of the porewater in CSH-gels, and a comprehensive overview and compilation of experimental data from earlier studies is presented by Chen et al. (2004). Based on interpretations of these earlier data and new experiments, Chen et al. (2004) suggest that the observed variability of the solubility of CSH-gels, especially at high Ca/Si-ratios, can be explained by different experimental approaches that may cause differences in the silicate structure, in particular the occurrence of Ca–OH bonds in CSH-gels with jennite-like structure. The results also suggest that CSH solids are present in different metastable phases that are susceptible to transforming /recrystallising into one another in the long term. Experimental studies by Baur et al. (2004), using radioisotopes to determine the dissolution–precipitation rates at equilibrium conditions of ettringite, monosulphate and CSH, show evidence that a complete reconstruction can be achieved during 1–4 years. Experimental investigations using combined small-angle neutron and X-ray scattering data have generated data on the density of CSH-gels that differ from previous estimates based on different drying techniques (Allen et al. 2007).

The dissolution of calcium silicate hydrates is accompanied by the leaching of other minerals in the cement. AF_m dissolution releases $Al(OH)_4^-$, which will also diffuse out and could induce precipitation of either secondary AF_m or ettringite in the presence of excess sulphate. The large molar volumes and crystalline morphologies of these minerals may reduce the porosity and mechanical strength of the concrete by producing micro-cracks (Lagerblad 2001). If the external groundwater contains dissolved carbon dioxide, precipitation of calcite might be expected. This has been found to reduce the degradation rate by sealing the pore network on the exposed surface of cement (Pfungsten 2001). Brucite may also be prone to precipitation at the cement–groundwater interface, due to its low solubility at high pH (Lagerblad 2001).

Important processes in concrete are the reactions between certain hydrated minerals and dissolved compounds transported in the pore water. The chemical composition of groundwater and the porewaters of the waste and waste packaging affect the rate of concrete barrier degradation. Laboratory experiments have shown that the degradation depth is highly dependent on the carbonate concentration of the external solution. A study by Moranville et al. (2004) showed that leaching depth decreases by a factor of 5 when the external water is in equilibrium with atmospheric CO_2 , due to the sealing produced by calcite precipitation at the cement–water interface. Also the availability of concrete mineral surfaces as sorption sites may be affected by such sealing processes. An external groundwater containing dissolved sulphate could also have a large impact on the longevity of concrete material (Höglund 2001) due to reaction with calcium aluminates causing ettringite precipitation. Ettringite has the ability to bind large amounts of water as waters of crystallisation, resulting in this mineral phase having a large molar volume. Unless sufficient pore volume is available to accommodate the mineral formed, this could result in cracking and mechanical deterioration of the concrete. The chloride concentration of the groundwater can also affect the long-term behaviour of the cement due to the precipitation of Friedelsalts (i.e. calcium-aluminium chlorides). A combined attack by sulphate and carbonate at low temperature may lead to precipitation of thaumasite ($Ca_3Si(OH)_6(SO_4)(CO_3) \cdot 12H_2O$) by reaction with AF_m/AF_t phases where silica from CSH-gel has replaced aluminate. This could cause the concrete to deteriorate (Justnes 2003). Different routes have been described for the formation of thaumasite, e.g. , i) where ettringite reacts with CSH and calcite, or ii) where CSH reacts with gypsum and calcite as suggested by Bellmann (2004). Damidot et al. (2004) have investigated the complex system of $CaO-Al_2O_3-SiO_2-CaSO_4-CaCO_3$ and suggest that thaumasite is stable at lower pH than ettringite but requires higher sulphate concentrations. Model exercises by Glasser and Matschei (2007) show a complex reaction sequence involving in the initial stages AF_m , hemi-carbo aluminate, ettringite, mono-carbo aluminate, portlandite and calcite, whereas the later stages involves mono-carbo aluminate, calcite, strätlingite, ettringite, CSH-gel, thaumasite, aluminium hydroxide, gypsum and amorphous silica.

Local supersaturation of minerals in the pore water may occur in response to any rapid changes of the external chemical conditions, such as release of dissolved compounds from the waste or sudden changes of the groundwater composition. This could result in the formation of colloidal material in the pore water. However, studies of the alkaline springs in Maqarin, Jordan (Smellie 1998) support the expectation that the colloid concentration would be low due to the high concentration of calcium ions in the vicinity of cement and concrete. The transport of colloids is described in depth in Section 5.4.5.

Under hyper-alkaline conditions there is a risk for alkali-silica reactions between the hydroxyl ions leached from the cement and reactive silica in ballast material. This causes formation of alkali-silica gels that increase in volume by uptake of water and exert an expansive pressure, eventually leading to fracture formation. This reaction is known to be deleterious for the mechanical strength of cement and concrete. The cements and ballast materials used for construction concretes in SFR are selected to avoid this type of reaction.

Minor amounts of special chemicals may be used as additives to the concrete, including lignosulphonate-based plastisiers (used to increase flow properties and workability of the fresh concrete mix before hardening) and retarders that may include sugar, sucrose, sodium gluconate, glucose, citric acid, and tartaric acid (used to slow down the early hydration). Typical amounts of additives are on the order of less than 1% up to 2% of the amount of cement in the concrete. Concrete additives are not known to cause degradation of the hardened concrete, whereas the macromolecular additives tend to be strongly sorbed to the concrete minerals (Hakanen and Ervanne 2006). The chemical stability of concrete additives is described in the **Waste process report**, Section 3.5.6. Aspects of the organic compounds that may be used as additives to the concrete as a substrate for microbial metabolism are treated in Section 5.4.8.

Chemical interactions with compounds leached from the waste

The migration of chemical species from the waste may initiate chemical reactions that could affect the integrity of the concrete barriers. Of particular importance is the presence of waste containing significant amounts of soluble salts or degradable materials such as ion exchange resins that may expel sulphate, and cellulose and plastics that may form organic acids, including iso-saccharinic acid (see detailed description in the **Waste process report**, Section 3.5.6).

Exposure to increased concentrations of dissolved species released from the waste may induce dissolution-precipitation such as: the formation of ettringite from monosulphate following increased exposure to sulphate; the formation of friedelsalt as result of increased chloride concentrations; or the precipitation of thaumasite as a result of increased exposure to carbon dioxide/dissolved carbonate species and sulphate. Further description of possible effects of different components in the waste that may affect cement based materials is given in the corresponding section in the **Waste process report**.

Vault and backfill

During closure, the empty voids outside the concrete barriers in the BMA vault are backfilled with sand or gravel. Depending on the choice of quality of the backfill material, the susceptibility to chemical interaction with the concrete barriers and the groundwater/ surrounding rock may differ. Assuming that the backfill material will resemble the ballast material used for the construction concrete, with a low content of reactive silica, the deleterious reaction with alkaline pore water from the concrete barriers would be unlikely to occur.

Even though the backfill material *per se* may be resilient against chemical interactions with the concrete pore water, the backfill may constitute a mixing point between the leachate from the concrete barrier and the ambient groundwater. At such mixing points the development of steep chemical gradients may cause precipitation of secondary minerals and the formation of supersaturated solutions may provide local environments where the formation of colloids could be possible. Description of the formation of colloids, e.g. cementitious colloids as a result of dissolution and precipitation processes in the waste is given in the **Waste process report**, Section 3.5.4. The transport of colloids in the BMA barriers is described in depth in Section 5.4.5.

Dependencies between process and system component variables

Table 5-12 shows how the concrete degradation processes in BMA concrete barriers influence, and is influenced by, all defined concrete barrier variables. In addition, the handling of each influence in SR-PSU is indicated in the table and more thoroughly discussed in the text below.

Table 5-12. Direct dependencies between concrete degradation processes in concrete barriers, vault and backfill in BMA and different system component variables and a short note on the handling in SR-PSU.

Variable	Variable influence on process		Process influence on variable	
	Influence present? Yes/No Description	Handling of influence How/If not – Why	Influence present? Yes/No Description	Handling of influence How/If not – Why
Geometry	No. Dimension of barriers indirectly influence the hydraulic and diffusive transport resistance.	Indirect influences of the concrete barrier geometry is considered in Sections 5.4.1 (advection), 5.4.2. (diffusion), 5.2.1 (water transport unsaturated) and 5.2.2 (water transport saturated conditions).	Yes. Dissolution–precipitation and recrystallisation of solid phases can modify the porosity of the system. Precipitation can affect backfill porosity. Chemical reactions may cause changes of the gross volume of barriers.	Porosity changes due to dissolution–precipitation reactions are considered. Changes of the gross volume of the concrete barrier due to chemical reactions with components in the groundwater and in waste are considered. Precipitation reactions in vault and backfill are considered.
Temperature	Yes. Temperature affects thermodynamic constants. Temperature changes may also cause fractures (see Section 5.3.1) that indirectly affects the concrete degradation.	Constant reference temperature assumed over long periods. Changed temperature considered in climate scenarios.	Yes, but the heat effect of initial hydration is expected to decline before closure. Any remaining heat generation at present time should be measured in situ. Long term heat effect expected negligible.	Considered insignificant.
Hydrological variables	Yes. The aggregation state affects the degradation processes. Magnitude of water flow has an indirect influence (5.4.1) via changes in water composition.	The aggregation state is considered.	No, only an indirect influence via changes in porosity and pore geometry that affect water flow, see Sections 5.2.2 and 5.4.1.	Not relevant.
Mechanical stresses	Yes. In general, mechanical stresses may affect chemical equilibria where volume changes of solid phases are involved. Rock fallout may locally cause such stresses. Also, indirect influence may occur via stresses that cause fracture formation, which in turn may enhance localised dissolution. See Section 5.3.1.	Mechanical stresses may locally affect the thermodynamic equilibria of solid–liquid where changes of the molar volume of the solid phase is involved. However, such local chemical effects are judged to have negligible impact on the overall concrete degradation. The impact is therefore judged insignificant for the safety analysis of SFR.	Yes. The formation of expansive solid phases, e.g. ettringite, may cause mechanical stresses. There is also a possible indirect influence, via reductions in strength that may possibly lead to fracture formation (see Section 5.3.1), or ultimately, collapse.	Mechanical stresses are estimated based on the formation of expansive mineral phases.
Material composition	Yes. Cement mineralogy and composition of ballast and backfill material determines which reactions may occur.	Included in modelling.	Yes. Modification of mineral composition and surface properties due to concrete degradation. Reactions with components in groundwater and waste.	Included in modelling.
Water composition	Yes. Affecting reactivity of concrete.	Included in modelling.	Yes. Reaction with minerals results in changes in porewater composition.	Included in modelling.
Gas variables	No direct influence identified. Indirectly the formation of CO ₂ in the waste could affect dissolution and precipitation.	Included in geochemical modelling of water composition and modelling of scenarios for gas generation, see Section 5.4.7.	No, only an indirect effect via water composition. CO ₂ will dissolve in the alkaline water and be consumed by reaction with Ca-containing alkaline minerals and form calcite.	Included in modelling of water composition, see Section 5.4.7.

Influence by Geometry

No direct influence has been identified.

Indirectly the geometry of the barriers influence the advective (see Section 5.4.1) and diffusive transport (see Section 5.4.2) of dissolved species in the groundwater which may affect the concrete degradation.

Influence on Geometry

Yes, a direct influence has been identified.

The geometry of the concrete barriers can be influenced directly by the gradual dissolution of alkaline minerals from the concrete. Precipitation of new solid mineral phases will also change the porosity of the concrete, and may result in clogging of pores. Recrystallisation will gradually increase the porosity and produce a less fine-structured pore geometry, which could increase the hydraulic conductivity and the diffusivity of the concrete. Precipitation of new minerals may also lead to partial or complete filling of fractures that may have formed in the concrete, e.g. calcite precipitation.

Changes in the gross volume of the concrete may occur due to internal chemical reactions with components leached from the waste, e.g. reactions between calcium aluminates in the concrete with sulphate expelled from the waste or by groundwater intrusion may cause formation of ettringite, potentially leading to an expansion and cracking of the concrete.

The alkaline leachate from the concrete may cause precipitation of new mineral phases in the vault and backfill, which is a likely mixing point with ambient groundwater. Precipitation of e.g. calcite may result in partial or complete clogging of vaults and backfill. This will have a direct influence on the geometry of the vaults and backfill by changing the porosity and pore structure.

Influence by Temperature

Yes, a direct influence has been identified.

Thermodynamic constants of chemical reactions are dependent on the temperature. However, the temperature in the concrete barriers is not expected to vary significantly in most short-term scenarios and, therefore, it is expected to cause minimal variations in the geochemical processes in the barriers. A constant reference temperature is assumed over long periods. Temperature differences between different components in the repository are likely to have levelled out during the operational phase, e.g. the heat of cement hydration and the heat generation due to radioactive decay are likely to have diminished to low levels. The overall judgement is that temperature variability would have insignificant impact on the dissolution and precipitation processes in the concrete.

Temperature changes, e.g. due to cooling by inflowing groundwater during resaturation of the repository by may induce mechanical stresses that may cause fracture formation in concrete barriers, see Section 5.3.1 which may indirectly affect the concrete degradation.

In the long-term, the occurrence of permafrost and glaciations will change the temperature in the repository, which may introduce major changes of importance for the thermodynamic constants. One apparent example is the change of stability field of AF_m versus AF_t with temperature, which could affect the porosity. Changed temperature is considered in climate scenarios. This is considered in the modelling; see further elaboration in the **Data report**.

Influence on Temperature

Yes, a direct influence has been identified.

The effect of concrete degradation processes on the temperature in the barriers is judged to be negligible since the heat effect of initial hydration is expected to decline before closure of the repository. The cement in the concrete barriers is expected to be essentially fully hydrated during the operational phase in SFR. Therefore, the heat due to cement hydration will evolve during the early operational period. Concrete degradation generates little heat and is thus judged to have a negligible impact on temperature in the BMA vaults. Long term heat generation is also expected to be negligible.

Influence by Hydrological variables

Yes, a direct influence has been identified.

The aggregation state will affect the degradation processes. Under frozen conditions the chemical degradation will cease when the exchange of reactants slows down due to the absence of free water. Small amounts of water may be present in narrow pores also under freezing conditions (see Section 5.1.2), but is judged to constitute negligible capacity for transport of dissolved species to sustain the chemical degradation processes.

The magnitude of water flow has an indirect influence on the degradation rate of concrete since it defines the exchange rate of water that is brought in contact and equilibrates with the concrete, see also description of the variable Water composition. Indirectly the water flow rate affects the reaction rates and transport of chemical components via changes in the water composition.

Influence on Hydrological variables

No direct influence identified.

The dissolution–precipitation and recrystallisation of mineral phases in the concrete barriers will influence hydrological variables indirectly via changes of the porosity and the pore structure of the concrete, which will affect the hydraulic properties. Dissolution of minerals may lead to increased porosity and increased hydraulic conductivity. Precipitation of secondary minerals may lead to clogging of pores which may lead to decreased porosity and decreased hydraulic conductivity. Recrystallisation means gradually increased porosity and less fine-structured pore geometry which could increase the hydraulic conductivity. The possible formation of expansive mineral phases, e.g. the formation of ettringite following exposure to sulphate released by the waste or supplied by the influx of groundwater, could give an indirect effect in the hydraulic properties of the concrete barriers via fracture formation, see also Section 5.3.1.

Influence by Mechanical stresses

Yes, a direct influence has been identified.

Mechanical stresses may affect chemical equilibria where the volumes of solid minerals change during the reaction. Mechanical stresses may also increase the available surface for reaction and thereby influence the kinetics of the dissolution reactions. Mechanical stresses may therefore affect the dissolution–precipitation and recrystallisation processes in the concrete barriers.

Indirectly the mechanical stresses may also induce fracture formation which in turn could increase the rate of water flow and thereby the rate of dissolution/ precipitation processes.

Influence on Mechanical stresses

Yes, a direct influence has been identified.

The groundwater in SFR contains fairly high concentrations of sulphate, likewise, some waste types have a potential to expel significant amounts of sulphate, which may result in formation of the expanding mineral ettringite. This may give rise to mechanical stresses in the concrete barriers. Therefore, the dissolution–precipitation and recrystallisation processes in the concrete barriers may affect the mechanical stresses in the repository.

Indirectly, dissolution/precipitation processes and to lesser extent recrystallisation processes may lead to reduced mechanical strength which could result in fracture formation, see Section 5.3.1, and eventually structural collapse. Dissolution of portlandite is reported to be the main cause for loss of strength in leached concrete (Carde et al. 1996).

Influence by Material composition

Yes, a direct influence has been identified.

This is one of the most important variables with regard to this process. The type and amount of each mineral present has a fundamental influence on the dissolution–precipitation and recrystallisation reactions that affect the concrete degradation and the chemical evolution of the system. The barrier geometry and the material composition define the mass of reactive components in the concrete. The total pool of these mineral phases will affect the geochemical evolution of the system. The corresponding reactions affect both the porewater composition and the minerals present in the system (i.e. newly precipitated minerals, amount of existing minerals and gradual recrystallisation of metastable minerals to more stable forms). The influence of material composition is included in the calculations of the chemical evolution of the porewater and the degradation of the concrete barriers through the material data selected (see the **Data report**). The amount and composition of backfill material may also have an impact on the degradation processes.

Influence on Material composition

Yes, a direct influence has been identified.

The concrete degradation processes will gradually change the material composition and surface characteristics. The relevant dissolution–precipitation and recrystallisation processes are considered in the geochemical modelling and may need consideration in kinetic modelling.

Influence by Water composition

Yes, a direct influence has been identified.

This is one of the most important variables with regard to this process. The porewater composition will determine which and to what extent the minerals in the system will dissolve or precipitate. The advective and/or diffusive exchange of porewater constituents with adjacent waste/waste packaging, as well as exchange with the ambient groundwater (see Sections 5.4.1 and 5.4.2), will introduce changes in the porewater composition, and therefore indirectly affects the concrete degradation processes. A reasonable assumption is that the different minerals maintain chemical equilibrium with the water passing through the concrete barriers; hence the dissolution rate will be proportional to the rate of water exchange. As the dissolution progresses, some concrete minerals may be depleted, thereby leading to changes in the thermodynamic equilibrium. Certain mineral phases formed in the concrete barriers as a result of chemical components expelled by the waste, e.g. chloride-rich salts, may have a high solubility in water and hence be more susceptible to dissolution. Input data for chemical modelling will reflect the influence of water composition.

Influence on Water composition

Yes, a direct influence has been identified.

This is one of the most important variables with regard to this process. The dissolution/precipitation of minerals in the concrete will modify the chemical composition of the concrete barrier porewater. Changes in water composition are calculated in the geochemical modelling. Recrystallisation processes often involve very small changes in the aqueous chemistry and will only slowly influence the water composition.

Influence by Gas variables

No direct influence has been identified.

Gases have an indirect effect on dissolution, precipitation and recrystallisation reactions via water composition. As an indirect effect, carbon dioxide released from the waste or transported by the groundwater is of particular importance, as it could lead to acidic dissolution of alkaline minerals, and/or calcite precipitation and the associated clogging of pores. The generation of hydrogen and methane in the repository will influence the redox conditions. The partial pressures of different gases and their effect on the thermodynamical stability of minerals are considered in the chemical modelling of the water composition. The dissipation of gases is treated in Section 5.2.3.

Influence on Gas variables

No direct influence has been identified. The gas composition may be affected indirectly by reactions that consume gas, via water composition. Examples include CO₂ formed by the degradation of components in the waste that will dissolve in the alkaline water in the repository to form carbonate which will react further with dissolving Ca-containing alkaline minerals and precipitate calcite. Another indirect effect could be that high pH buffering may hamper microbial processes active in gas formation, see Section 5.4.8.

Boundary conditions

There are no particular boundary conditions to discuss for these processes. The relevant boundary conditions in order to treat the processes quantitatively are those of the transport processes that control the solutes transport between the cement matrix, the waste, the concrete packaging and the groundwater as adjacent system components, i.e. the boundary conditions of the processes diffusion (see Section 5.4.2) and advection (see Section 5.4.1). The boundaries of this analysis are the barriers themselves with exchange of mass and heat (likely relevant only during long term transitions between temperate to glaciation periods) from the waste/waste package and the surrounding geosphere considered.

Model studies/experimental studies

A large amount of research has been reported in the scientific literature involving accelerated laboratory leaching tests of relevance for dissolution, precipitation and recrystallisation processes in concrete; examples of important papers are those of Carde et al. (1996), Faucon et al. (1998), Catinaud et al. (2000), Saito and Deguchi (2000), Moranville et al. (2004) and Maltais et al. (2004).

Reactive transport-based models of concrete degradation require that geochemical species and processes are selected for inclusion. The inclusion of K⁺, Na⁺, Mg²⁺, Ca²⁺, SO₄²⁻, OH⁻, Al(OH)₄⁻ and Cl⁻ is claimed in Maltais et al. (2004) to be sufficient to describe most degradation processes. However other sets of chemical components have also been proposed, e.g. the addition of Si (Höglund 2001, Moranville et al. 2004, Hidalgo et al. 2007), Fe (Möschner 2007), CO₃²⁻ (Höglund 2001) and F⁻ (Savage et al. 2011).

In their review, Lagerblad and Trägårdh (1994) have pointed out that the early models used to describe the leaching of alkali and calcium hydroxides in the SFR safety assessment were oversimplified. The criticism reflects the simplifications made when calculating the leaching of alkali hydroxides as dissolved substances, and the fact that the counter effect of alkali metal ions in the groundwater was neglected, leading to a rapid depletion of alkali metal ions in the concrete material. Furthermore, the leaching of calcium hydroxide and calcium silicate hydrates (CSH-gel) was represented as processes independent of the alkali metal leaching. Experimental studies by Glasser et al. (1985) indicate retention of sodium and potassium by hydrated cement minerals. Modelling of cement degradation by Berner (1990) addressed the alkali metal retention by assuming that 5% of the remaining inventory of sodium and potassium is released in each pore water exchange cycle. In the model study by Höglund (2001), the leaching of alkali hydroxides was represented by ion exchange processes, also taking into account the counter ion effect of the surrounding groundwater. The model for the ion exchange processes was calibrated against experimental data by Lagerblad and Trägårdh (1994). The modelling results showed a significantly different leaching behaviour for the alkali metal hydroxides compared to the previous estimates. A similar modelling approach has been reported by Savage et al. (2011).

Further, in modelling studies by Höglund (2001) and Moranville et al. (2004) the leaching of different calcium compounds, e.g. portlandite, CSH-gel and AF_m/AF_t-phases, was coupled to the leaching of alkali hydroxides. This has the effect that during the early period, the leaching of calcium compounds is suppressed by the high pH maintained by the alkali hydroxides in the pore water. The available data for thermodynamic calculations have significantly improved since the early studies for SFR, especially regarding the preferential leaching of calcium from CSH-gels with variable C/S-ratio. Extensive experimental data have also been provided, combined with modelling, for different chemical systems including different combinations of calcium, silica, aluminium, sulphate, carbonate, sodium, potassium and chloride (Stronach and Glasser 1997, Perkins and Palmer 1999, Baur et al. 2004, Barbarulo et al. 2007, Birnin-Yauri and Glasser 1998, Damidot et al. 1992, 2004a, b, Damidot and Glasser 1993, 1995, de Silva and Glasser 1993, Glasser et al. 1999). Faucon et al. (1998) used

a combination of experimental studies and modelling to investigate the re-precipitation of secondary minerals including AF_m , ettringite and calcite in a cement exposed to demineralised water. Detailed studies of solid-solutions between Al- and Fe-ettringite minerals have been presented by Möschner (2007), with experimental data presented also for Fe-monosulphate and Fe-monocarbonate. The formation of Fe-ettringite phases is slower than the corresponding Al-ettringite, time constants on the order of a few months and few weeks respectively (Möschner 2007). It was also found that Al-ettringite is more stable than Fe-ettringite at high pH, Fe-ettringite being gradually replaced by Fe-monosulphate at $pH > 13.1$ (Möschner 2007).

In early studies for SFR the limiting C/S-ratio for the CSH-gel was assumed to be 2.5, and this has been shown to be too high (Stronach and Glasser 1997). The CSH-gels are commonly represented by a solid solution series that varies in composition roughly between $C_{1.8}SH$ and $C_{0.8}SH$. Berner (1990) modelled the incongruent dissolution, assuming CaH_2SiO_4 and $Ca(OH)_2$, and SiO_2 and CaH_2SiO_4 , respectively as end-members for calcium-rich and calcium-depleted CSH-gels, and adjusting the apparent solubility product as a function of the Ca/Si-ratio. In the study by Höglund (2001), the CSH-gel was represented by three discrete CSH mineral phases: $C_{1.8}SH$, $C_{1.1}SH$ and $C_{0.8}SH$. The $C_{1.8}SH$ -phase may coexist with portlandite in the more alkaline regime, whereas $C_{0.8}SH$ may coexist with amorphous SiO_2 in highly leached concrete. In the intermediate regime, between highly alkaline and highly leached conditions, $C_{1.1}SH$ coexists with either $C_{1.8}SH$ or $C_{0.8}SH$ depending on the C/S-ratio. The model applied by Höglund (2001) accounts for the gradual transformation of portlandite and CSH-gel between these different mineral phases. Moranville et al. (2004) and Gaucher et al. (2005) used a similar approach. Kulik and Kersten (2002) report an upper end-member composition corresponding to $C_{1.7}SH$. In a modelling exercise of the early hydration reactions of Portland cement, a limiting composition of the CSH-phase corresponding to $C_{1.67}SH$ was used (Savage et al. 2011).

It has been concluded by Benbow et al. (2007) that modelling of cement degradation is complex, and the process will be controlled by the incongruent dissolution of the CSH gel over long periods. Benbow et al. (2007) have compared three different models representing the gradual degradation of CSH, developed by Börjesson et al. (1997), Walker (2003) and Sugiyama and Fujita (2005). The models by Börjesson et al. (1997) and Walker (2003) use calculations of the excess energy of the solid solution as a function of its composition as a method for determining the solid phase activity coefficients. Sugiyama and Fujita (2005), on the other hand, applied conditional equilibrium constants related the solid phase activity coefficients. Walker et al. (2007) presented modelling of non-ideal solid solution aqueous solution applied to a synthetic CSH. The models also differ with respect to the selection of solid-solution end-members; Börjesson et al. (1997) and Walker (2003) consider portlandite and a CSH gel, whereas Sugiyama and Fujita (2005) consider portlandite and $SiO_2(s)$. A comprehensive literature review of different approaches to represent the CSH-gel in models is given in Soler (2007). In a recent comparative study, different model approaches have been applied to mimic experimental data on the early hydration processes in Portland cement (Savage et al. 2011).

Recent efforts have been made to improve the modelling capabilities with respect to the incongruent dissolution–precipitation of CSH-gel phases in the cement (Grandia et al. 2010). Some criticism is given to earlier modelling attempts where modelling of the incongruent dissolution–precipitation of the CSH-gels was attempted as a solid solution process. The main criticism is that the CSH-gels are in fact not crystalline phases and hence are not solid solutions. Grandia et al. (2010) have nevertheless used two different methods to estimate equilibrium constants for discrete mineral compositions in the assumed solid solution series to represent the CSH-gels. The approach resembles those used by Höglund (2001) and Gaucher et al. (2005), although it is more detailed with up to 21–30 discrete mineral phases representing the CSH-gels.

The long-term leaching of concrete has been reported to follow a dissolution and precipitation sequence involving the following steps (Hidalgo et al. 2007):

- Dissolution of portlandite.
- Decalcification of CSH-gel.
- Silicate polymerisation.
- Incorporation of tetrahedral and/or hexagonal aluminium in the silica structure to give an aluminosilicate gel.

Model studies of cement degradation have also been used to estimate the impact of leaching on the physical properties (i.e. porosity, diffusivity) and how these changes affect the leaching process. Some of the models involve adjusting parameters to fit curves derived from experimental data (Yokozeki et al. 2004) and some others are either “pure” random models (Bentz and Garboczi 1992) or “hybrid” models, where randomness is constrained by appropriate user-defined probability distributions (Marchand et al. 2001). A pure mechanistic approach for cement degradation modelling requires the coupling of multi-component solute diffusion and chemical reactions taking place in the system. Dimensionless analyses of diffusion and reaction rates demonstrate the adequacy of a local equilibrium assumption for coupled reactive transport modelling of cement leaching (Barbarulo et al. 2000). By this approach, a mixed non-linear set of equations can be solved numerically. The domain of the problem could be represented either as a homogeneous medium, obtained by averaging the variables of interest over a representative elementary volume, or a pore structure modelled on the basis of microstructural information, such as that provided by mercury intrusion porosimetry, or on the reconstruction of the microstructure by means of random models (Bentz 1999). The latter has been addressed by Moranville et al. (2004).

The possible impacts of the release of different salts from evaporator concentrates intended for disposal in SFR on cement and concrete have been studied by geochemical and reactive transport modelling (SKBdoc 1417785). The importance of sodium, potassium, magnesium, chloride, sulphate, carbonate, nitrate, phosphate, sulphide and ionic strength was evaluated, as well as the effect of pretreatment of the salt concentrates with lime. Model results indicate the presence of halite (NaCl), hydroxiapatite ($\text{Ca}_5(\text{PO}_4)_3\text{OH}$), magnesite (MgCO_3), thenardit (Na_2SO_4) and thermonatrit ($\text{Na}_2\text{CO}_3 \cdot \text{H}_2\text{O}$) in the evaporator concentrates.

Experimental investigations have been performed to study the impact of salts on concrete stability, mimicking the composition of evaporator concentrates in SFR (SKBdoc 1032170). Different cement mixtures were tested and the mechanical strength, weight increase and swelling of test specimens were measured. The results show no deleterious effects during an initial period of one year testing.

Model studies of the long-term stability of concrete barriers in the SFR repository have addressed the dynamic impact by changes of porosity and diffusivity in leaching processes (Cronstrand 2007). The model calculates the porosity change due to precipitation–dissolution processes and adopts a relationship suggested by Bentz and Garboczi (1992) to describe the effect on diffusivity.

Studies of the leaching of portlandite and CSH-gel have shown that the depletion of portlandite is responsible for about 70% of the loss of concrete strength, whereas only a minor part of the loss can be attributed to leaching of CSH-gel (Carde et al. 1996).

Experimental evidence has also been reported on long-term concrete leaching through the analysis of old, man-made, cementitious structures (Álvarez et al. 2000, Lagerblad 2001, Yokozeki et al. 2004). Over 100 years exposure to water, calcium leaching and concrete degradation has occurred to a depth of approximately 100 mm (Yokozeki et al. 2004).

New experimental studies have been initialised within the Äspö-project as well as by the Ringhals power station. The emphases of these studies are on reactions and degradation processes in concrete materials. The Äspö experiments are expected to run for up to 40 years (SKB 2010b).

The chemical degradation of cement conditioned ion exchange resins may potentially be a source of chemical compounds that could affect the concrete barriers. Examples include the release of sulphate ions from sulphonate acid-type ion exchange resins, which may lead to ettringite formation, and the release of carbonate ions from carboxylate-type ion exchange resins that may form carbohydrate minerals. The risk of thermal and chemical degradation of carboxylate-type ion exchange resins has been investigated by literature survey and experiments by Allard et al. (2002). It was concluded that the ion exchange resins are very stable under alkaline conditions and that the main form of degradation that may occur is likely to involve decarboxylation.

Natural analogues/observations in nature

Natural analogues to alkaline cements have been extensively studied at the hyperalkaline springs in Maqarin in northern Jordan (Alexander and Smellie 2002, Smellie 1998). The Maqarin natural analogue site is considered to be a good representation of the processes occurring in a cementitious repository during portlandite and CSH-gel phase dissolution. Three different stages of concrete degradation have been identified:

1. An early, hyperalkaline stage dominated by leaching of sodium and potassium hydroxides.
2. An intermediate stage with a slightly lower pH determined by dissolution of portlandite.
3. A late and less active stage with a lower pH, dominated by dissolution of silica.

Tobermorite is a naturally occurring mineral (roughly with the composition $\text{Ca}_5\text{Si}_6\text{O}_{16}(\text{OH})_2 \cdot n\text{H}_2\text{O}$) that can be seen as a crystalline analogue to CSH-gels in cements. Tobermorite can also be obtained as a crystalline product by gently heating CSH-gels in cement (Parsons 2010), thus indicating the importance of changes in temperature for long-term recrystallisation processes.

CSH-gel has been reported to be persistent in nature over periods of 10,000 years, despite it being metastable with respect to crystalline phases such as tobermorite and jennite (Stronach and Glasser 1997).

The occurrence of different ettringite-group minerals in natural alkaline environments are reviewed by Möschner (2007) including Al- and Fe-ettringites.

Time perspective

Chemical reactions related to hydration can occur for as long as unhydrated clinker minerals remain in the concrete barriers. Hydration of clinker minerals may continue over extended periods of time, most commonly in concretes with a low w/c-mixing ratio. The w/c-mixing ratio is therefore usually chosen to ensure full hydration, and this would be expected to be complete within the first year post-mixing, i.e. long before repository closure. Over time, the barrier function relevant for the safety analysis shifts in the following way:

- For the initial period – short-term, the chemical conditions established by the initial hydration reactions dominate, which create a hyper-alkaline porewater of alkali metal hydroxides and calcium hydroxide. The mechanical strength may be relatively high and may be of significant importance for the repository performance. The physical barrier properties may be of relatively high importance, e.g. low hydraulic conductivity and low diffusivity.
- For the short-term – mid-term, e.g. during a few hundred years from closure (*this needs qualification by modelling exercises in the safety analysis*), the mechanical strength and the physical barrier function may be reduced, e.g. by fractures and leaching, whereas the chemical buffering still would be expected to be significant.
- In the long-term, e.g. during a few thousand years from closure (*this needs qualification by modelling exercises in the safety analysis*), the mechanical and physical barrier functions are likely to be low, and the chemical buffering gradually decreases as calcium is depleted by leaching.
- In the very long-term, e.g. after tens of thousands of years from closure (*this needs qualification by modelling exercises in the safety analysis*), the concrete barrier is likely to be completely degraded and exert a minor impact even on the chemical conditions.

Since concrete leaching is mainly a coupled diffusion-reaction phenomenon, the time needed for complete degradation of concrete barriers will be highly dependent on the relative surface area of the concrete where diffusion exchange with the adjacent waste/waste packaging and/or groundwater can take place. This parameter will be related to the geometrical dimensions of the concrete barriers. The porosity and permeability increase due to concrete degradation need to be taken into account since this could mean a change of Péclet-number describing the flow conditions, which could otherwise lead to non-conservative estimates of the calculated degradation times.

Long-term climate change will influence the temperature at repository depth. Temperature changes will affect thermodynamic equilibria and may lead to gradual transformation and recrystallisation of the concrete minerals. One example is the change of stability field of AF_m versus AF_l with temperature,

which could affect the porosity. This may impact the mechanical, hydraulic and chemical properties of the concrete barriers.

During permafrost conditions the likelihood of any dissolution, precipitation or recrystallisation processes in the concrete is negligible. However, freezing may have significant impact on the mechanical integrity of the concrete barriers; see Sections 5.1.2 and 5.3.1.

Handling in the safety assessment SR-PSU

The durability of the concrete barrier is important as its degradation can affect the pH in the near field of the repository. The rate of degradation will essentially define the geochemical conditions of the contained waste and will influence the degradation rate of the waste packaging. Therefore, the durability of the concrete barriers is evaluated by long term reactive transport modelling, accounting for the coupling between dissolution/precipitation of minerals and porosity/diffusivity/hydraulic conductivity changes.

The models are set up to evaluate the long term durability of the concrete barriers quantitatively, including the time evolution of the main physical and chemical properties (Höglund 2014), as well as any impacts from the adjacent waste packaging and dissolved components released from the cement matrix and the conditioned waste (Cronstrand 2014).

Handling boundary conditions:

The degradation of any cementitious components in the repository will be highly dependent on the external boundary conditions. For the concrete barriers, the relevant boundary conditions are set by the adjacent waste and waste packaging, and by the groundwater. For the repository as a system, the rate of external groundwater inflow and the chemical composition of the external groundwater have a strong influence on the out diffusion of ions from the concrete barriers, and an advective groundwater flow would accelerate the degradation of concrete barrier. The chemical composition of the groundwater, e.g. high carbonate concentrations, may cause calcite to precipitate which may reduce the porosity at the concrete surface or even fill in fractures in the concrete barrier. Other chemical processes, e.g. the release of sulphate or chloride from the waste may cause precipitation of new minerals that may block the pores of the concrete, or result in formation of expansive mineral phases that could cause fracture formation in the concrete barriers, are also possible. Depending on the capacity of the concrete to undergo chemical reactions that consume such chemical components expelled by the waste/waste packaging, a gradual impact on the surrounding concrete barriers may occur when this capacity becomes depleted. Hence, the occurrence of such processes may therefore influence the concrete degradation rate and the integrity of different barrier systems and are considered in the safety analysis.

Handling influences between variables and the process:

Concrete degradation phenomena have a strong coupling between physical and chemical processes. For this reason, solute transport and geochemical reactions are coupled in the models to account for relevant processes such as dissolution, precipitation and recrystallisation of CSH-gels, different calcium-aluminate/calcium-ferrite-phases, gypsum, calcite, and the corresponding changes of the porosity and internal pore geometry. In turn, changes in porosity and internal pore structure are coupled with solute diffusion and advective water flow, in order for the numerical models to account for these fundamental relationships.

Handling coupling to other processes:

Degradation of the concrete barriers will be affected by the degradation of the waste and waste packaging, and vice versa. The concrete barriers will interact with the groundwater and will to certain extent protect the cement waste matrix and the waste packaging from direct contact with the flowing ambient groundwater. However, the concrete barriers are also exposed to chemical components released from the waste/waste packaging. Coupled reactive transport models account for these couplings and the magnitude of these effects is evaluated.

The interaction of the hyper-alkaline plume with the external groundwater may trigger mineral dissolution/precipitation processes that could influence the groundwater flow and solute transport properties of the BMA vault and backfill, as well as in the geosphere close to the repository (see the **Geosphere process report**). Coupled reactive transport models account for these couplings and the magnitude of these effects is evaluated.

Handling of uncertainties in SR-PSU

Uncertainties in mechanistic understanding

A major uncertainty is related to the complex solubility behaviour of CSH-phases, which has been represented by successively more complex modelling approaches in studies of cement degradation.

Uncertainties also concern the fate and properties of different calcium sulpho-aluminates, calcium sulpho-ferrites (AF_m and AF_t), as well as similar calcium alumino- and calcium ferrite- mineral phases formed by reactions with chloride and carbonate. Of particular interest here are the volume changes of the solid phases accompanying these reactions, which could result in clogging of pores, and the potential precipitation/recrystallisation of expanding minerals causing fractures in concrete. The mechanical pressures exerted by such mineral reactions are less well established and may require further study or to be handled by conservative assumptions in the SR-PSU.

Other uncertainties are associated with the long-term evolution of the pore network and the diffusivity in the cement paste of the concrete. The diffusivity depends strongly on the porosity values, and the coupling between the dissolution processes and the resulting micro-structural changes are not fully understood.

Certain waste types contain chemical components such as boron, hydrazine, magnesium and other metal salts, the effects of which have not been previously demonstrated in safety assessments. Potential impacts on the concrete barriers of components released by cement-conditioned waste containing salts, sludges, evaporator concentrates and ashes are considered in the SR-PSU. Potential effects are included in the coupled reactive transport modelling. The thermodynamic databases used for such modelling may need complementary data for the relevant chemical components. In particular for salt concentrates, high ionic strength solutions may occur for which conventional corrections of the chemical activity of different chemical species are no longer valid. The uncertainty introduced by this is considered in the SR-PSU.

Model simplification uncertainty in SR-PSU

Model calculations to evaluate the degradation of the concrete barriers can be made using a simplified geometry, where the concrete barriers are represented by a slab, on one side in contact with the waste packaging/cement waste matrix, and on the other side in contact with the vault, the backfill and the groundwater.

The solid phases considered is a simplification of the CSH-phases that are formed as a result of cement hydration. In addition, the representation of the AF_m and AF_t and similar compounds that may form as a result of reactions with sulphate, chloride and carbonate, as well as components released by waste containing salts, sludges, evaporator concentrates and ashes, and different components transported by the groundwater, need to be implemented in the coupled reactive transport modelling.

The concept of thermodynamic equilibrium in the system means that no secondary mineral will be precipitated as long as the chemical conditions remain constant. True equilibrium may be hampered by the existence of metastable minerals that only very slowly are recrystallising to more stable phases. However, whenever chemical gradients are introduced, e.g. as result of chemical exchange with the groundwater, the waste or waste packaging in the repository, new chemical equilibrium may develop which may result in supersaturation of secondary minerals leading to precipitation. The uncertainties introduced by local equilibrium assumptions are studied in the safety assessment by studying the sensitivity to different assumptions and by applying alternative thermodynamic data sets as a basis for model calculations.

However, owing to the present status of the 1BMA concrete barriers where significant fractures have been observed, the evaluation of the concrete degradation needs to consider the presence of fractures. This means that advective flow through the fractures needs consideration, and suggests that diffusion may not be the rate determining process at fracture locations. This means that the geometric representation of the degradation processes in and near fractures need to be two-dimensional. It can be expected that the presence of fractures could result in significantly higher degradation rates than would be calculated for a homogeneous concrete without fractures. The presence of fractures will also mean that the flow pattern in the BMA vault, backfill and concrete barriers will be unevenly distributed with higher flow rates in the fractures. This means that the residence time of water flowing in the fractures will be significantly lower than in the intact concrete, therefore the validity of the assumption of local equilibrium between water and different minerals need to be checked, and if found inadequate would require a kinetic modelling approach to be applied.

The presence of a significant number of supporting rods in the concrete, left during the construction phase of the concrete barriers, may constitute pinhole penetrations through the concrete. This could significantly influence the water flow patterns in the immediate vicinity of the supporting rods. Hence, this needs to be considered in the modelling of the degradation of concrete barriers.

The implications of these simplifications are discussed in the **Model summary report**.

Input data and data uncertainty in SR-PSU

The main uncertainties concern the composition of the cement matrix and the contained waste, the thermodynamic stability of CSH-gels, as well as the AF_m and AF_t and similar compounds that may form as a result of reactions with sulphate, chloride and carbonate. In these calculations, data on and uncertainty related to the content of soluble and/or degradable components of the waste that may result in release of sulphate, chloride and carbonate in increased concentrations need special consideration. The presence of fractures, as well as the presence of supporting rods, in the concrete barriers could mean a significantly changed flow pattern in the BMA vault and the local flow rates in such fractures/around supporting rods are presently not available. The implication of this is discussed in the **Model summary report**.

Adequacy of references supporting the handling in SR-PSU

The references are judged to be adequate and sufficient to support the handling in SR-PSU. All supporting references are either peer-reviewed articles or documents which have undergone factual review.

Other references have been used for general background information, and not all of these have been peer-reviewed to the same standard.

5.4.7 Aqueous speciation and reactions

Overview/general description

Aqueous speciation describes the chemical forms of dissolved elements under specific geochemical/physical conditions. In the BMA barriers, the porewater constituents reflect the barrier materials themselves and the aqueous inputs from the geosphere or waste materials and packaging. The chemical processes controlling dissolved concentrations are described in Sections 5.4.3–5.4.6, and the aqueous speciation of the system influences these processes. Chemical reactions occur when a constraint is put on a system at equilibrium, i.e. any change due to migration or dissolution of chemical species may result in aqueous chemical reactions occurring.

The major factors affecting speciation are the pH, Eh, and the concentration and type of other chemicals in the system, including the presence of complexing agents. pH is fundamentally important as it defines the balance between protons and hydroxyl ions in the solution. A proton rich, acidic environment favours cationic species while, under alkaline conditions, both deprotonation and complexation by hydroxyl ligands increase the abundance of anionic species. Eh is of critical importance for redox sensitive elements, with the low Eh associated with a deep repository favouring reduced oxidation states. A key example of a redox sensitive element in BMA wastes is iron, which corrodes from Fe(0) to Fe(II) and/or Fe(III), depending on the Eh/pH conditions. Sulphur is another important example and can be reduced from S(VI), as SO_4^{2-} , to S(-II), as HS^- , by sulphate reducing bacteria.

The oxidation state therefore also affects the aqueous speciation and solubility of an element, and its reactions with other species. Eh/pH diagrams can be constructed for simple aqueous systems to show the variations in the basic speciation of an element. However, advanced geochemical calculations are required to account for all the different interactions occurring within a complex system. The speciation controls exerted by pH, Eh, dissolved ions and presence of complexing agents are important in the BMA because they control a) the overall solubility of each element present with respect to chemical precipitation, b) the interactions of the element with surface sorption sites (Sections 5.4.3 and 5.4.4), and c) the potential for the species to migrate with groundwater flow.

Groundwater chemistry. The groundwater surrounding the BMA will influence the character of the porewater within the barriers. Table 5-13 summarises the range of ion concentrations and water properties in the local groundwater in 2006 (SKB 2008a) and shows the reference values calculated by Höglund (2001). The sulphide content of the SFR groundwater has been assessed separately and is generally > 0.4 mg/L (Tullborg et al. 2010).

Over the first 1,000 years post closure, land rise may move the shoreline above the SFR facility (SKB 2008a), although recent sea level measurements in the Baltic may indicate changes in this trend (Hammarklint 2011). Shoreline displacement would change the groundwater to freshwater, 1,000–10,000 years post closure (Höglund 2001). The water would remain reducing and be of a similar pH, but would have lower concentrations of most dissolved ions. However, it should be noted that the carbonate concentration is expected to be three times higher than in the previous groundwater supply, and silicate will be very similar to the previous concentration.

Concrete barrier porewater. The concrete barriers will exert a very significant influence on the aqueous speciation and reactions in the porewater via the high pH and ionic strength generated. The chemical evolution of the concrete barriers over time is described in SKB (2008b) and Section 5.4.6, and the porewater chemistry of fresh and leached (portlandite phase) concrete are illustrated in Table 5-13. When the portlandite has leached, incongruent dissolution of calcium silicate hydrate phases will occur resulting in a gradually lowering of the pH to about 10 (SKB 2008b).

The Eh of the concrete barrier porewater is expected to become reducing rapidly after closure, with consumption of oxygen introduced during the open phase through microbial respiration (Section 5.4.8) and oxidation of the iron rock bolts, reinforcement bars (Section 5.4.9) and waste steel drums (**Waste process report**). The reducing character of the surrounding groundwater will also help maintain reducing conditions over time.

Table 5-13. Comparison of groundwater and cement porewater components (mg/L).

	2006 groundwater (lowest values in range) [*]	2006 groundwater (highest values in range) [*]	Reference current groundwater [†]	Future fresh groundwater [‡]	Fresh cement porewater [§]	Leached cement porewater [#]
HCO ₃ ⁻	69	133	100	300		
SO ₄ ²⁻	170	480	500	50	3.8	1.9
Cl ⁻	2,800	4,200	5,000	45	2.1	71
F ⁻	1	1.5				
Na ⁺	1,300	1,610	2,500	100	640	69
K ⁺	6	33	20	4	3,200	3.9
Ca ²⁺	320	1,050	430	35	36	800
Mg ²⁺	106	190	270	9		
Mn _{tot}	0.7	2.9				
Fe	0.43	35				
Si as SiO _{2(aq)}			5.66	5.9	22	0.084
Al _{tot}					1.1	0.054
OH ⁻					1,900	610
pH	7.4	7.6	7.3	7.5	> 13	12.5
Ionic strength (M)	0.10	0.17	0.18	0.0089	0.12	0.061

* Nilsson 2007, † Höglund 2001, ‡ Lagerblad and Trägård 1994, # Engkvist et al. 1996.

Backfilled vault porewater. The backfill material used in the vault could affect the groundwater chemistry through dissolution and sorption reactions, but this cannot be assessed as the backfill has not been defined. The reference groundwater values provided by Höglund (2001) include equilibration with calcite, dolomite and quartz, thus it is unlikely that the backfill will change the groundwater chemistry from this significantly.

Waste/waste packaging leachate. The aqueous speciation of leachate from the waste and waste packaging is addressed in the **Waste process report**, and will have a high pH and be geochemically reducing. It will contain a complex mix of dissolved species including organic species, chloride, carbonate and sulphate. The composition will change over time as cement, bitumen and wastes degrade, and will affect the aqueous speciation and reactions in the barriers.

Dependencies between process and system component variables

Table 5-14 shows how the processes Aqueous speciation and reactions influence, and is influenced by, all defined BMA system variables. In addition, the handling of each influence in SR-PSU is indicated in the table and more thoroughly discussed in the text below. The system variables and their definition within this report are presented in Section 4.3.

Influence by geometry

No direct influence identified.

Aqueous speciation will be affected indirectly by the surface area of the solid material per unit volume, via water composition. The more surface area exposed per unit volume water, the higher the number of available binding sites for sorption of aqueous species. Therefore, the porosity, pore characteristics and amount and character of fractures affect the solid/solution distribution of aqueous species. The volume and dimensions of the barrier are also important over the lifetime of the BMA as they define the longevity of the concrete and therefore aqueous speciation over time.

Influence on geometry

No direct influence identified.

Aqueous speciation has an indirect effect on geometry via sorption, precipitation and dissolution reactions (Section 5.4.6), which affect the porosity and pore characteristics of the barriers.

Influence by temperature

Yes, a direct influence has been identified.

Temperature is a fundamental factor in chemical reaction rates and the position of chemical equilibria and will be defined (as a matter of course) in the geochemical modelling. However, the temperature will not vary significantly until periods of very significant climate change (permafrost and glaciations) and so temperature variations are considered to be negligible. Climate change scenarios account for more significant temperature changes.

Influence on temperature

No direct influence identified.

Although hydration of cement mixes results in the release of heat from exothermic reactions, this heat would dissipate long before the closure of the repository. Aqueous exothermic reactions taking place is judged to be of minor importance to the temperature in the repository.

Table 5-14. Dependencies between the process Aqueous speciation and reactions and the BMA system component variables and a short note on the handling in SR-PSU.

Variable	Variable influence on process		Process influence on variable	
	Influence present? Yes/No Description	Handling of influence How/If not – Why	Influence present? Yes/No Description	Handling of influence How/If not – Why
Geometry	No, although porosity and surface area (including fractures) influence aqueous speciation indirectly via water composition.	Not relevant.	No, although aqueous speciation controls reactions such as sorption (Sections 5.4.3 and 5.4.4), precipitation and dissolution (Section 5.4.6), which in turn affect geometry.	Not relevant.
Temperature	Yes, temperature affects reaction rates and thermodynamic equilibria.	Repository temperature is an input to the geochemical modelling. Variations in temperature are assumed to be negligible, except during climate scenarios.	Yes, if exo/endothermic reactions take place.	No, main exo/endothermic reactions occur prior to closure.
Hydrological variables	Yes, pressure affects aqueous speciation. Indirect influences result from the aggregation state and the degree of saturation, via water composition. There may also be further indirect influences resulting from the flow if flow rates are sufficient for chemical kinetics to be important.	Yes, pressure is a minor effect that is included in the geochemical modelling.	No, although aqueous speciation can affect the aggregation state via water composition.	Not relevant.
Mechanical stresses	No, although fractures resulting from mechanical stress can influence hydrological variables, and pressure can influence precipitation reactions (see Section 5.4.6).	Not relevant.	No, although aqueous speciation affects the stability of the concrete barrier indirectly (see Section 5.4.6).	Not relevant
Material composition	No, although the material composition affects aqueous speciation indirectly through dissolution, precipitation (Section 5.4.6) and sorption (Sections 5.4.3 and 5.4.4) processes, and water composition.	Not relevant.	No, although aqueous speciation affects material composition via water composition and dissolution, precipitation (Section 5.4.6) and sorption (Sections 5.4.3 and 5.4.4) processes.	Not relevant.
Water composition	Yes, water composition controls aqueous speciation and reactions.	Included in the geochemical modelling.	Yes, aqueous speciation and reactions control water composition.	Included in the geochemical modelling.
Gas variables	No, although gas solute-exchange could impact on water chemistry and reactions indirectly, via water composition.	Not relevant.	No, although aqueous speciation and reactions could generate or use gases (also relates to microbial processes), i.e. have an indirect effect via water composition.	Not relevant.

Influence by hydrological variables

Yes, a direct influence has been identified.

Aqueous speciation will be affected by the pressure to a small extent. There are also a number of indirect effects resulting from hydrological variables in BMA. Firstly, the freezing out of dissolved substances as ice crystals form (e.g. Belzile et al. 2002) will affect the water composition and therefore aqueous speciation. Secondly, the amount and transport of water and degree of saturation will affect the solid (or surface area)/solution equilibria and impact on dissolution and sorption processes (see Sections 5.4.3, 5.4.4 and 5.4.6).

Influence on hydrological variables

No direct influence identified.

The aqueous speciation influences the hydrological variables indirectly via water composition, as dissolved components such as salt affect the aggregation state by changing the freezing point of water.

Influence by mechanical stresses

No direct influence identified.

Mechanical stresses in themselves are unlikely to influence aqueous speciation and reactions, but it should be noted that fractures arising from mechanical stresses will have an indirect effect via dissolution and precipitation reactions. Also, mechanical pressure has an effect on the equilibrium position of reactions involving changes in the volume of the solid phases in the system, and therefore affects aqueous speciation indirectly. Both effects are addressed in Section 5.4.6.

Influence on mechanical stresses

No direct influence identified.

However, reactions can occur that cause volume expansion of the solid phase, increasing the mechanical stress, see Section 5.4.6.

Influence by material composition

No direct influence identified.

The amount, composition and surface characteristics of the barrier material, the type and amount of chemicals in the barrier and extent of cement hydration have an indirect influence on the aqueous speciation via to dissolution, precipitation and sorption processes (Sections 5.4.3, 5.4.4 and 5.4.6).

Influence on material composition

No direct influence identified.

The aqueous speciation will affect the amount, composition and surface characteristics of the barrier material and the type and amount of chemicals in the barrier indirectly through dissolution, precipitation and sorption processes. Reactions with cement minerals are described in Section 5.4.6. Complexing agents may enhance the degradation of the cement through Ca^{2+} complexation. The type and amount of organic materials and components that can be utilised by microbes as nutrients and energy sources will also affect the material surface characteristics through biofilm development and the release of organic acids (Section 5.4.8). The barrier materials will evolve and degrade over the lifetime of the repository due to the presence of the aqueous phase and the exact pathways depend on the aqueous speciation, as well as water flow (Gaucher et al. 2005).

Influence by water composition

Yes, a direct influence has been identified.

The water composition defines the aqueous speciation. More specifically the redox conditions, pH, ionic strength, concentration of dissolved species, type and amount of colloids and/or particles and the amount and composition of dissolved gas define the aqueous phase and the speciation of each element within it, under the prevailing temperature and pressure conditions.

Influence on water composition

Yes, a direct influence has been identified.

The aqueous speciation controls the water composition and the solubility of the species within the system. The chemical species define the redox potential, pH, ionic strength, concentration of dissolved species, amount of colloids and particles and the amount and composition of dissolved gas. The aqueous speciation therefore affects the salinity, density and viscosity of the water.

Influence by gas variables

No direct influence identified.

The amount, composition, volume, and pressure degree of saturation of gases will influence the aqueous speciation indirectly via water composition, as these affect the degree of dissolution in the aqueous phase. Dissolved gases can be either chemically active or inactive, depending on their interactions in the water. For example, CO₂ and H₂S interact with the water producing species such as HCO₃⁻ and HS⁻, while noble gases and N₂, to an extent, are inactive and retain their gas composition (Hallbeck and Pedersen 2008). The dissolution of H₂, CH₄ and CO₂ will influence the chemical composition and therefore aqueous speciation through redox and acid-base processes.

Influence on gas variables

No direct influence identified.

Aqueous speciation will affect the amount, composition, volume and pressure, degree of saturation of gases, via water composition, as the saturation limit of dissolved gas is affected by pH and aqueous speciation. An example of this is the solubility of CO₂ in water, which is reduced at lower pH because H⁺ ions push the carbonate equilibria towards H₂CO₃ thus limiting further dissolution of CO₂.

Boundary conditions

The boundaries of this process are the barriers themselves with exchange of mass from the waste/waste package and the surrounding geosphere considered.

Model studies/experimental studies

Aqueous speciation and reactions are addressed in a wide range of experimental and modelling studies and the resultant thermodynamic speciation data are compiled in databases. These databases are updated regularly and evaluated, for example within the OECD Nuclear Energy Agency Thermochemical Database Project (<http://www.nea.fr/html/dbtdb/>).

The porewater evolution of the concrete barriers of the SFR has been modelled: e.g. Höglund (2001), Gaucher et al. (2005) and Cronstrand (2007). Modelling by Cronstrand (2014) and Höglund (2014) included temporal changes in temperature and water salinity on the concrete barrier degradation and porewater.

Natural analogues/observations in nature

Aqueous speciation is omnipresent in nature and examples of important reactive aqueous systems include the carbonate system of the oceans, dissolution of gaseous sulphur dioxide emissions resulting in acid rain, and CO₂ levels in blood controlling the pH of the blood and the respiratory reflex. These examples illustrate the sensitive relationship between chemical speciation and pH. The sulphur dioxide example also demonstrates the importance of redox chemistry as SO₂ undergoes oxidation, as well as hydrolysis, to form sulphuric acid.

Time perspective

The aqueous speciation and reactions in the BMA barrier system will change very significantly over time. The three key time related processes are 1) the leaching and degradation of the concrete barrier over time, which defines the core aqueous conditions and reactions taking place, 2) the changing input from the degrading waste and waste packaging over time, and 3) the changes in groundwater from the current saline water to post glaciation melt water, and its intrusion into the barrier system.

Handling in the safety assessment SR-PSU

Aqueous speciation and reactions are central to the geochemical model used for the BMA. The aqueous speciation defines the solution phase environment that radionuclides will be present in, and thus radionuclide speciation (Section 5.5.1), competition for surface binding sites (Sections 5.4.3 and 5.4.4) and/or ligands, dissolution of solid-associated radionuclides, the over saturation of the solution with respect to direct precipitation, co-precipitation and the development of new binding phases (Section 5.4.6), the stability of colloids (Section 5.4.5), and ultimately the transport of radionuclides (Section 5.5.2).

Handling of uncertainties in SR-PSU

Uncertainties in mechanistic understanding: The mechanistic understanding of inorganic aqueous speciation and reactions is fairly mature. However, the validity of the thermodynamic database used requires careful evaluation, which is demonstrated by the need for the on-going OECD Nuclear Energy Agency Thermochemical Database Project (<http://www.nea.fr/html/dbtdb/>). Thermodynamic databases can differ in the species included and the stability constants of these species, leading to differences in predicted solution phase speciation. The challenges associated with defining the speciation and stability constants of the wide range of organic complexing agents in a repository have also been reviewed (Keith-Roach 2008).

Model simplification uncertainties: The model requires simplified input parameters, which are outlined in the **Data report**, and these will introduce uncertainties in the output. The selection of parameters to define the system affects the level of uncertainty introduced. Stability constants are dependent on temperature, thus variations in the temperature of the repository over time and/or space may introduce uncertainties. The use of thermodynamic data implies that the system is at thermodynamic equilibrium, but some reactions are kinetically very slow. Slow reaction kinetics add the greatest uncertainty in time periods and physical zones with higher flow rates. The major chemical reaction schemes in the BMA vault are studied systematically to identify specific reaction steps controlled by kinetics and evaluate their impact.

Input data and data uncertainties: The greatest uncertainties in the data are associated with the input from the waste and waste packaging, due to the high heterogeneity of the wastes and the associated challenges predicting the composition of the waste leachate over time. The groundwater chemistry is dependent on whether shoreline displacement occurs, thus this requires careful assessment. Evolution of the cement porewater is dependent on water flow rates, thus faults and fractures existing or occurring in the concrete barrier, leading to uncertainties.

Adequacy of references supporting the handling in SR-PSU

The references are judged to be adequate and sufficient to support the handling in SR-PSU. All supporting references are either peer-reviewed articles or documents which have undergone factual review.

Other references have been used for general background information, and not all of these have been peer-reviewed to the same standard.

5.4.8 Microbial processes

Overview/general description

Biological processes involve many reactions that are either very slow or do not occur in sterile lifeless chemical systems, e.g. the reduction of sulphate to sulphide (Goldstein and Aizenshtat 1994, Cross et al. 2004). This is because life has the ability to over-run activation energy barriers and other energetic constraints that prevent spontaneous chemical reactions. Life is possible from -20°C up to above 113°C , where in general all life processes stop. Life is also possible within a large pH range, from pH 1 up to at least pH 12 (Yumoto 2007, Pedersen 2004b). However, the highest reported growth pH values reported for alkaliphiles are 12.5 (Takai et al. 2001) for *Alkaliphilus transvaalensis* isolated from a deep African goldmine and pH 13 for the soil bacterium *Paenibacillus daejeonensis* sp. nov (Lee et al. 2002). However in BMA pH is likely to be maintained at hyperalkaline conditions throughout the lifetime of the repository. According to modelling results presented in Cronstrand (2007) pH at the surface of the concrete barrier will decrease from initial 13.3 to 12 after about 100,000 years, making it less hostile for microbes. Most alkaliphilic bacteria have optimal pH in the range 8–10, but some are able to survive at pH above 12 (Yumoto 2007).

At extreme conditions, such as the hyperalkaline environments that will be the case in SFR due to the extensive occurrence of concrete and cement in barriers as well as in some waste forms, microorganisms are expected to have low activity (Pedersen 2004b). Most of the activity will be in the waste (see the **Waste process report**). After closure pH is expected to drop from initially very alkaline, in the waste to dilution when the repository is waterfilled. According to Aviam et al. (2004) microbial corrosion of cements and concrete usually does not start until pH drops to about 9. Gypsum may form at the surface as a result of microbial activity, but only at pH < 10 and aerobic conditions. Thus, under the conditions that the repository remains anaerobic this will not be a problem.

Fermentation

Fermenting microorganisms thrive in anaerobic systems containing large amounts of organic material and is not expected in the concrete barriers.

Respiration

A general microbial process is respiration, which must proceed in all active microorganisms, except for those using a fermentative metabolism. Respiration mainly influences the barrier variables material composition, water composition, gas composition.

Oxygen is a very potent electron acceptor and, as a result, will be rapidly consumed during microbial activity. When oxygen has been consumed nitrate will be the preferred electronacceptor, then Mn(IV), Fe(III), sulphate, sulphur and finally carbon dioxide are reduced.

(For more details, see the **Waste process report**).

Methylation and alkylation.

See the **Waste process report**.

Biofilm formation

Many microorganisms attach and grow on surfaces of all types in aquatic systems. Attachment to a surface, such as a barrier wall, is commonly looked upon as a more favourable state compared to being unattached at least in a system with flowing water. Typically, microbial biofilms form where gradients of nutrients and sources of energy are present. The solid itself may constitute the nutrient and energy source due to added organic components and possibly waste components diffusing out from the wastes. Microbial biofilms can reach a thickness of several centimetres when the availability of organic carbon is large, in other cases biofilms can be as thin as a monolayer of bacteria in the range of some micrometers. Biological iron oxides (BIOS) that produce dense mats of rusty material with iron- manganese and sulphur-oxidising bacteria (Anderson et al. 2006) on positions in SFR where groundwater is percolating over walls and tunnel floors will form during the aerobic operational phase. These are not expected to form on the concrete barrier walls due to the hyperalkaline pH in the porewater. Upon closure conditions will become anaerobic within shortly and the production of these mats will stop and degradation of them will start. Once the repository is filled with water the pH conditions is expected to become hyperalkaline. (Pedersen 2004b) have shown that microbes are able to attach to surfaces at hyperalkaline conditions. However, comparing Fennoscandian microbial groundwater flora with the natural hyperalkaline analogue in Maqarin the number of attached cells was two orders of magnitude lower at hyperalkaline conditions. This could be interpreted as the attaching microbes were inactive and did only attach because of surface interaction forces (Pedersen 2004b).

Anabolic processes

See the **Waste process report**.

Dependencies between microbial processes and BMA concrete variables

Table 5-15 shows how microbial processes are influenced by and influence all SFR BMA concrete barrier variables. The handling in SR-PSU is also indicated in the table and further described under the relevant heading. Observations made by Pedersen et al. (2004b) show that although biofilms formed at surface under hyper alkaline conditions, the cells did not grow.

Geometry; The smallest size a microorganism can take is a sphere of about 0.2 µm diameter. This excludes microbial processes from all cavities smaller than this diameter, including cavities that may be larger, but with access restricted to pores smaller than 0.2 µm diameter. Porosity and the fracture characteristics will influence microbial mobility in the concrete barriers. Any fracture larger than about 1 µm will be available for migration of microorganisms. Many microorganisms follow gradients such as those that may form in fractures through the barriers between outside groundwater in sand and gravel and the inside water that is influenced by the wastes mixed with concrete and bitumen. A fracture through a concrete barrier will consequently favour free mobility of microorganisms in groundwater to the BMA waste containers.

Table 5-15. Direct dependencies between microbial processes and the defined BMA barrier variables and a short note on the handling in SR-PSU.

Variable	Variable influence on process		Process influence on variable	
	Influence present? Yes/No Description	Handling of influence How/If not – Why	Influence present? Yes/No Description	Handling of influence How/If not – Why
Geometry	Yes. Porosity and the fracture characteristics influence microbial mobility in concrete.	The first 1,000 years pH is expected to be too high for the microbes to be active.	Yes. Microbially induced acid production may corrode concrete and increase porosity.	Negligible effect as the hyperalkaline pH will limit the microbial activity.
Temperature	Yes. The rate of microbial processes increases with increasing temperature.	Negligible effect in the expected temperature interval.	Yes. In cases with high microbial activity, heat is generated, not likely in BMA.	No, negligible effect as microbial activity is expected to be low.
Hydrological variables	Yes. The extent of microbial processes increases with increasing flow. Microbial activity depend on availability of water and saturation.	No, negligible effect as microbial activity is expected to be low.	Yes. Microbial biofilms may clog flow paths and distribution of flow paths.	No, negligible effect as microbial activity is expected to be low.
Mechanical stresses	No.		No, but indirectly. Microbial gas production from the waste can introduce mechanical stress on the barriers.	No, negligible effect as microbial activity is expected to be low.
Material composition	Yes. Microbial process rates depend on the availability of organic materials and corrosion products such as hydrogen.	No, negligible effect as microbial activity is expected to be low.	Yes. Microbial processes may degrade organic barrier material.	No, negligible effect as microbial activity is expected to be low.
Water composition	Yes. The content of electron donors and acceptors and pH will influence microbial processes.	No, negligible effect as microbial activity is expected to be low.	Yes. Microbial processes will influence concentrations of groundwater components, dissolved gases, E _h and to some extent pH.	No, negligible effect as microbial activity is expected to be low.
Gas variables	Yes. Hydrogen and methane can be oxidised by microbial processes.	No, negligible effect as microbial activity is expected to be low.	Yes. Microbial processes generate gases. Risk for carbonation of concrete.	No, negligible effect as microbial activity is expected to be low.

Many microorganisms can induce acid conditions, directly via the process fermentation, and indirectly via production of sulphide that will oxidise to sulphuric acid, or ammonium to nitric acid, in contact with oxygen (Gu et al. 2011). When produced, these acids will corrode concrete and increase the porosity. In cases where organic material is available from the wastes or from added organics to the concrete microbial activity is possible. Initially high pH in the concrete barrier can be mitigated by organic and inorganic acid production by microbial processes. It is likely that this process, if possible, will start on the outside of the barrier on fracture positions and eat itself inwards under the production of acids that will lower pH, and increase pore size and fracture diameters.

Temperature; Microbial processes in the BMA concrete barrier will be more rapid at high temperatures. In cases with high microbial activity, significant heat can be generated. Such activity would not be expected in the barriers themselves, but at the boundaries between wastes with high loads of wet organic material and barriers, heat may evolve. Well known analogues are composts that can be self-sustained with heat from biodegradation processes. As the BMA waste is well contained in cement and bitumen, the availability to organic material over time is expected to be slow and a heat effect from microbial processes is probably negligible in BMA barriers.

Hydrological variables; The microbial activity is low at low water activity and increases with increasing water activity as has been demonstrated in a full scale sand-bentonite barrier experiment (Stroes-Gascoyne et al. 1997). The extent of microbial processes increases with increasing flow because the potential for biofilm formation is positively correlated to flow. During operation, biofilms will tend to form on the barrier walls, on the outside BMA barriers in the sand layers and on the floor where groundwater is draining into the BMA, or flowing parallel to the barrier walls. Biofilms may also contribute to sealing of fractures thereby influencing the distribution of water flow. After closure of a BMA vault, flow rates are expected to be slow and the biofilm formation process will be reduced but continued on all positions with a flow rate. Microbial biofilm process activity will consequently correlate positively with water flow. Once biofilms are formed, strong gradients may form through the films with significant effects on the outside of the concrete barriers as has been found in underground tunnels (Anderson and Pedersen 2003, Pedersen et al. 2008).

Mechanical stresses; Many microbial processes generate gases such as carbon dioxide, di-nitrogen, nitrous oxide and methane from these sources. Significant pressure build-up can consequently occur as a result of microbial processes in the waste which can introduce mechanical stress on the barriers. However, it is not likely that microbial processes inside the barriers, or on the surface of the concrete barrier will create stresses and strains on the concrete barrier.

Material composition; Microbial activities depend on the availability of organic barrier materials and corrosion products from corroding armour, rock bolts and waste steel barrels such as hydrogen. Hydrogen that reaches microorganisms on and inside the concrete barrier will enhance microbial process rates. Microbial processes can degrade organic barrier material and can thereby contribute to the degradation of the concrete barriers by reducing the effect from various organic additions to the barrier concrete (Diercks et al. 1991).

Water composition; Concentration of metabolites such as carbon sources, electron donors and electron acceptors in water that reaches the concrete barrier will select for different microbial processes. It is assumed that most concrete barrier water is groundwater migrating towards the wastes through the vault and backfill barriers. The active microbial processes will run for as long as the respective metabolites for different processes are available. Microbial processes will significantly influence the composition of groundwater migrating towards the wastes by their reduction of electron donors during respiration, which will change states of oxidation and aggregation of several groundwater components. Removal of oxygen, nitrate and hydrogen from the groundwater composition and production of nitrous oxide and nitrogen gas, ammonium, sulphide, ferrous iron, carbon dioxide and methane will have a profound influence on groundwater composition and may have an influence on the BMA concrete barrier. Microbial processes will also influence Eh and in some cases significantly alter pH. In particular, pH depends on the production of organic acids from fermentation, and the oxidation of sulphide to sulphuric acid and ammonium to nitric acid. Both bacteria and fungi are well known for production of organic acids that can corrode concrete (Gu et al. 2011).

Gas variables; Hydrogen from anaerobic metal corrosion processes can be oxidised by microbial processes; a large effect is obtained if oxygen is present. Anaerobic hydrogen oxidation with sulphate has been identified as an important microbial process. This process outputs sulphide when hydrogen

is oxidised with sulphate. Therefore, hydrogen may imply sulphide production where microbial life is possible in the barriers. Active microbes can produce gas if organic carbon is available for metabolism. In particular, the microbial production of carbon dioxide may locally promote carbonation of concrete (Malhotra 2011).

Dependencies between microbial processes and BMA vault and backfill variables

Table 5-16 shows how microbial processes are influenced by and influence all SFR BMA vault and backfill variables. The handling in SR-PSU is also indicated in the table and further described under the relevant heading. Several of the processes have been described previously in relation to the SFR waste systems (Pedersen 2001).

Geometry; The porosity and pore characteristics will allow most types of microorganisms to be active in this barrier. For the period when the repository is open, and water is filling up the vault and sand layers, microbial biofilms can develop. In the presence of oxygen, dense mats of biological iron oxides (BIOS) can develop (Ferris et al. 1999). This BIOS material will influence porosity and pore characteristics

Temperature; The rate of all microbial processes discussed here increases with increasing temperature from below 0°C up to about 113°C. However, temperature is not expected to deviate significantly from the ambient groundwater temperature in SFR. This will favour natural groundwater bacteria and restrict bacteria brought with the waste from higher temperature domains.

Table 5-16. Direct dependencies between microbial processes and the defined BMA vault and backfill variables and a short note on the handling in SR-PSU.

Variable	Variable influence on process		Process influence on variable	
	Influence present? Yes/No Description	Handling of influence How/If not – Why	Influence present? Yes/No Description	Handling of influence How/If not – Why
Geometry	Yes. Porosity and pore characteristics influence microbial mobility.	Process neglected as pH is expected to be hyperalkaline.	Yes. Microbial processes will clog pores and alter porosity.	Process neglected as pH is expected to be hyperalkaline.
Temperature	Yes. The rate of microbial processes increases with increasing temperature.	Process neglected as pH is expected to be hyperalkaline.	Yes. In cases with high microbial activity, heat is generated.	Process neglected as pH is expected to be hyperalkaline.
Hydrological variables	Yes. The extent of microbial processes increases with increasing flow. Microbial activity depend on availability of water and saturation.	Process neglected as pH is expected to be hyperalkaline.	Yes. Microbial biofilms may clog flow paths and change direction of flow paths.	Process neglected as pH is expected to be hyperalkaline.
Mechanical stresses	No.		No.	
Material composition	Yes. Microbial processes can utilise the anaerobic corrosion product hydrogen from corroding rock bolts.	Process neglected as pH is expected to be hyperalkaline.	No.	
Water composition	Yes. The content of electron donors and acceptors and pH will influence microbial processes.	Process neglected as pH is expected to be hyperalkaline.	Yes. Microbial processes will influence concentrations of groundwater components, dissolved gases, Eh and to some extent pH.	Process neglected as pH is expected to be hyperalkaline.
Gas variables	Yes. Hydrogen and methane can be oxidised by microbial processes.	Process neglected as pH is expected to be hyperalkaline.	Yes. Microbial processes generate gases.	Process neglected as pH is expected to be hyperalkaline.

Hydrological variables; Microbial activity depends on availability of water and the degree of saturation. The activity is low at low water activity and increases with increasing water activity as has first been demonstrated in a full scale sand-bentonite barrier experiment (Stroes-Gascoyne et al. 1997). The extent of microbial processes increases with increasing flow because the potential for biofilm formation is positively correlated to flow. During operation, BIOS biofilms will tend to form in all positions where anaerobic groundwater meets an oxygenic environment. During growth, BIOS biofilms fix carbon dioxide to organic carbon that later can be degraded. This type of red-brown biofilm is very common in SFR wherever groundwater intrudes to the tunnel system. The BIOS can be degraded by anaerobic processes after closure.

Mechanical stresses; Effects are not expected. Microbial gas generation will most probably not be significant.

Material composition; Microbial process rates will benefit from the anaerobic corrosion product hydrogen from corroding armour, metal in shotcrete and rock bolts. Hydrogen that reaches microorganisms in the vault and backfill will enhance microbial process rates such as sulphate reduction to sulphide. Microbial process may also induce corrosion of metals (Little and Jason 2007).

Water composition; Concentration of metabolites such as carbon sources, electron donors and electron acceptors in groundwater that intrudes in the vault and backfill material will select for several microbial processes. The microbial processes will be active for as long as the respective metabolites for the process are available. Microbial processes will influence the composition of groundwater migrating towards the concrete barrier and to the waste containers significantly by their reduction of electron donors during respiration, which will change states of oxidation and aggregation of important groundwater components. Removal of oxygen, nitrate and hydrogen from the groundwater composition and production of nitrous oxide and nitrogen gas, ammonium, sulphide, ferrous iron, carbon dioxide and methane will have a profound influence on groundwater. Microbial processes will also influence Eh and in some cases significantly alter pH. These processes are not expected to influence the vault and backfill materials, but the formation of BIOS biofilms depend on water composition.

Gas variables; Hydrogen from anaerobic metal corrosion processes can be oxidised by microbial processes; a large effect is obtained if oxygen is present. Anaerobic hydrogen oxidation with sulphate has been identified as an important microbial process. This process outputs sulphide when hydrogen is oxidised with sulphate. Therefore, hydrogen may imply sulphide production where microbial life is possible in the barriers.

Table 5-16 shows direct dependencies between microbial processes and the defined BMA vault and backfill variables and a short note on the handling in SR-PSU.

Boundary conditions

Microbial growth is possible on the outside of concrete containers. The pH gradients will control microbial growth, the limit is not well known.

In the backfill, too, microbial growth is possible, and may be significant in the presence of an advective flow. The effect will, however, be low under stagnant hydraulic conditions. Acidic exudates excreted from bacteria will deteriorate the cement component in concrete.

Microbial growth is possible on concrete structures and may be significant in the presence of an advective flow. It is also possible that there is microbial activity within the cemented waste form (Gorbunova and Barinov 2011). These boundary conditions are not well known.

The most favourable barrier position for microbes, with respect to available energy, is on the barrier surfaces facing towards the wastes and the outside surfaces of the barriers facing groundwater environments. The growth of microbes would predominantly occur on these surfaces, locally generating large numbers of microbes, relative to the amounts of available sources of energy and electron acceptors. However, fermentation processes will proceed without access to external electron acceptors. The magnitude, direction and distribution of groundwater flow over BMA barriers will influence the transport of microbes and, much more importantly, the transport of e-acceptors to, and degradation products from, microbes dwelling in BMA barrier systems (Pedersen 2001). Oxygen is a very potent e-acceptor and in situations where oxygen gradients develop over the barriers, sulphuric and nitric acid production from sulphide and ammonium, respectively, is possible.

Model studies/experimental studies

Model studies on the influence of microbial processes on BMA barriers remains to be performed. A model study of waste degradation in a concrete box has been performed in Olkiluoto, Finland (Small et al. 2008). There was a considerable heterogeneity within the experiment such that pH varied from 5.5 to 10 between wastes and the concrete barrier. It was found that microbial activity can reduce the high pH from concrete and shape the environment from a concrete influenced high pH type to a neutral pH type environment. Consequently, the high pH generated by concrete cannot be taken as a general safety measure against microbial processes. The outcome of the Finnish experiment showed that microorganisms can change the environment from unfavourable (high pH) to favourable (neutral pH) via their metabolic processes.

Test methods were developed by Rogers et al. (2003) to assess microbial influenced degradation of cement-solidified wastes. It was found that microbial biofilms that developed on the concrete surfaces promoted cement degradation by acid production. Sterile controls degraded initially, but the degradation ceased after about two weeks, while the microbial system continued to degrade the concrete. A study by Aviam et al. (2004) confirmed that biodegradation of cement is an important process to account for in radioactive waste disposal. Sulphur oxidising bacteria caused weight losses of the cement samples and fractures were observed in the test material.

In Gorbunova and Barinov (2011), a drilled core sample was taken from a cement monolith from a low and intermediate level radioactive repository at the depth interval 0.1–8 m. After 15–45 years of storage all specimens regardless of depth were found to be moist and porous indicating degradation of the cement matrix. Microbial tests showed presence of NRB, IRB, SRB, fermenting bacteria and fungi. An experimental study conducted at optimal conditions with NRB cells from a withdrawn cement specimen showed that they are capable to release μ molar levels of low molecular mass organic acids per day. Their main conclusion was that biodegradation due to formation of organic acids and acid gases (CO_2 and H_2S) reacting with the cement matrix could, within a ten or hundred years perspective, make it more porous, decreasing its strength and therefore also its capability to retain radionuclides.

Natural analogues/observations in nature

There are many observations of microbial degradation of concrete in man-made structures. However, there are some important differences. Firstly, many analogues are exposed to lights and photosynthetic microorganisms develop; such organisms will not develop in the dark SFR. Secondly, exposure to oxygen is common in most man-made systems. Because oxygen will be absent most of the SFR time, except for the dry operational stage, such analogues are not particularly relevant. Still, the open phase is long and some microbial processes may proceed to considerable effects.

A very illustrative example of how microbial biofilms powerfully can change the conditions on concrete surfaces was found in the Finnish access tunnel to a future spent fuel repository. Dense biofilms were growing on the shotcrete on the tunnel walls. Due to microbial sulphide oxidation, pH reached about 1 in several positions (Pedersen et al. 2008). This analogue demonstrates the power of microbial processes in an excellent way. The up to 10 mm thick tunnel biofilms developed in less than a year, meaning that there is a long time window during the open phase when such biofilms may build up.

The formation of BIOS in the Äspö hard rock laboratory tunnel is well studied (Ferris et al. 1999, Anderson and Pedersen 2003, Anderson et al. 2006).

Time perspective

Microbial processes will be on-going throughout the lifetime of the repository. The dominating process at different time interval may differ. During the open phase, and other time windows when oxygen is present, inorganic acid production can be significant. The production of biofilms and BIOS in the vault and backfill can be large, but is expected to cease after closure and water saturation. The process of carbon dioxide production and carbonation of concrete can proceed most of the repository life time, as long as there is organic material available for microbial processes.

Handling in the safety assessment SR-PSU

Process neglected as pH is expected to be hyperalkaline in the cement and concrete barriers during the first 100,000 years (Cronstrand 2007).

Handling of uncertainties in SR-PSU

Uncertainties in mechanistic understanding: The basic scientific mechanisms governing the described microbial processes are well understood but their relevance for BMA barriers and extent in BMA barriers is not known. Studies have not been performed under relevant SFR conditions. However, such studies are possible to perform in SFR that has been in operation for a significant time.

Model simplification uncertainties

The modelling performed by Cronstrand (2007) does not take microbial processes into account, which introduces uncertainties to the models as Gorbunova and Barrinov (2011) showed that microbes are able to grow in the pores in concrete. After 100,000 years pH is lower than 12.5 in the whole concrete barrier even if microbial processes are excluded.

Input data and data uncertainty

Microbial processes are not taken into account as there are no data to model.

Adequacy of references supporting the handling in SR-PSU

The references are judged to be adequate and sufficient to support the handling in SR-PSU. All supporting references are either peer-reviewed articles or documents which have undergone factual review.

5.4.9 Metal corrosion

In BMA, the concrete barriers comprise the reinforced concrete structures in terms of bottom, lid, outer walls and inner walls. In addition, to enhance the operational safety, e.g. to rock fall-out, rock bolts and shotcrete are used. The metal used for reinforcement and rock bolts is carbon steel. In BMA the empty space in the interior of the compartments and the backfill surrounding the concrete structures do not contribute with any metals.

In BMA the major source of metals (iron/steel, aluminium and zinc) is found in the waste packages (Moreno et al. 2001). Corrosion of metallic waste and metals in waste packaging is described in the **Waste process report**.

In BMA metal corrosion of reinforcement bars is of importance for predictions of degradation of concrete structures as well as for estimates of oxygen depletion and for rates of subsequent gas formation.

Overview/general description

A general description regarding steel corrosion during aerobic and anaerobic conditions is given below.

Aerobic conditions

During construction and operation of the SFR facility, air will enter the BMA vaults via the ventilated tunnels. Due to the prevalent humid conditions aerobic corrosion of steel components is expected to take place and signs of corrosion are observed. The reinforcement bars in the concrete structures and form rods can be well protected; however, insufficiently covered surfaces will corrode. Rock reinforcement and bolts in walls and roof of the rock vault will only be partly protected by shotcrete and corrosion will take place.

Steel corrodes under aerobic conditions in accordance with the following generalised reaction for different corrosion products:

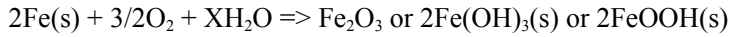

At repository closure, groundwater will enter the vaults and entrapped air will start to dissolve. Aerobic conditions will prevail until the dissolved oxygen is consumed by aerobic corrosion or by some other oxygen consuming process such as microbial processes. The redox conditions will at first be unevenly distributed in the system but with time anaerobic conditions will evolve in the whole system.

The pH and the redox conditions in the surrounding water will influence the corrosion process. The corrosion resistance for different conditions can be described by a Pourbaix diagram. In Figure 5-1, the zones for iron corrosion, passivation and immunity are shown.

Anaerobic conditions

The corrosion of steel under anaerobic conditions is an important mechanism for gas formation and hydrogen gas is produced in accordance with the following reactions:

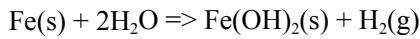

Since Fe(OH)_2 is thermodynamically instable it may be converted to magnetite in a second step known as the Schikorr reaction:

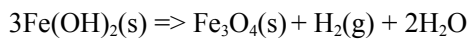

The corrosion of iron results in the formation of corrosion products with a larger volume, see Figure 5-2.

Anaerobic corrosion that takes place with a relatively uniform reduction of thickness over the surface of a corroding material is often named general corrosion. There are also several processes that can lead to localised corrosion at the surface such as pitting corrosion, crevice corrosion, stress corrosion cracking, and corrosion influenced by microbial activity.

The concentration of anions such as chloride, nitrate and sulphate in the water will influence the corrosion process. For example high concentrations of chloride anions can induce both localised corrosion (pitting corrosion) and general corrosion of steel.

The corrosion rate is strongly influenced by the pH, the water composition and if oxidising or reducing conditions prevail. In general the corrosion rates are low in alkaline environment and higher in neutral solutions and in solutions with high chloride concentration. Anaerobic corrosion rates for carbon steel at alkaline to neutral conditions are reported to be in the order of 0.01 to 1 μm per year (**Data report**). For example, it will take more than 100,000 years for a 16 mm reinforcement bar embedded in concrete to be totally corroded if a uniform corrosion rate of 0.05 μm per year is assumed.

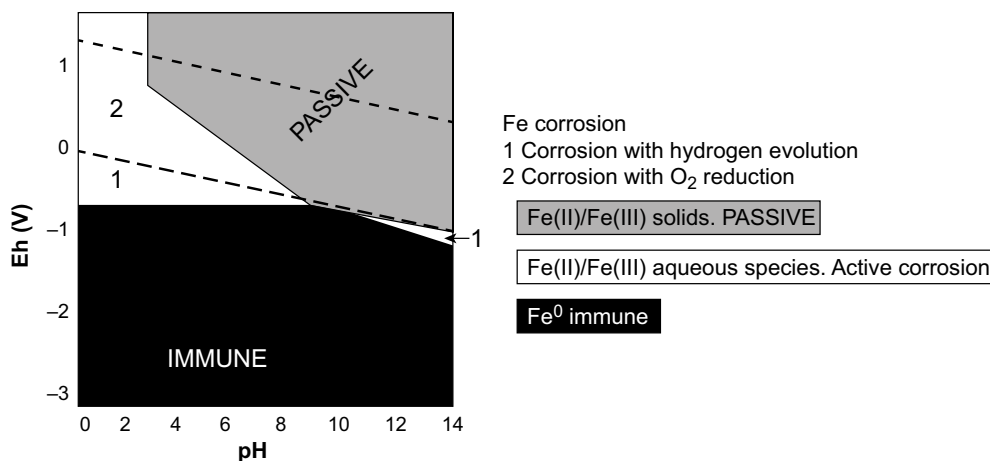

Figure 5-1. Pourbaix diagram for iron calculated for a concentration of 10^{-5} M (figure from the *Waste process report*, section Metal corrosion).

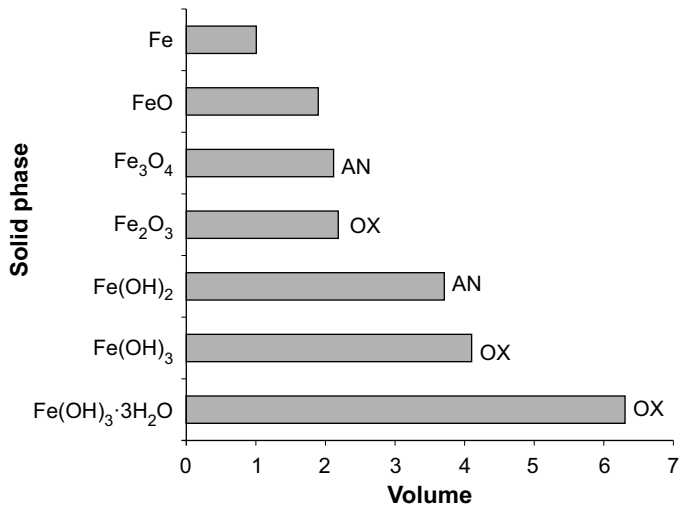

Figure 5-2. Relative molar volume for different iron solid phases. AN: most likely formed from corrosion under anaerobic conditions; OX: most likely formed under aerobic conditions. (Figure from the *Waste process report*, section Metal corrosion).

Metal corrosion processes may be influenced by galvanic effects from natural telluric currents or induced currents from electrical conductors. Of special interest in SFR are induced electrical currents during the operational period arising from the nuclear power plant in Forsmark and the high voltage direct current transmission cables Fenno-Skan 1 and 2. The influences of the Fenno-Skan cables on the safety functions are being investigated.

Dependencies between process and system component variables

Table 5-17 shows how metal corrosion is influenced by the specified set of physical variables and how the process influences the variables. In addition, the handling of each influence in SR-PSU is indicated in the table and more thoroughly discussed in the text below.

Influence by geometry

The dimensions (thickness and surface area) of the reinforcement bars in the concrete structures and the dimensions of rock bolts and reinforcement in shotcrete will affect the extent of corrosion. In addition, the properties of the materials protecting the iron components such as thickness of protecting layers and material porosity will have an influence on the corrosion process.

Influence on geometry

The corrosion of steel components embedded in concrete or shotcrete will influence the porosity of the surrounding material through the formation of corrosion products with a larger volume. In the vicinity of reinforcement bars this can (via mechanical stresses) lead to fracturing of concrete structures.

Influence by temperature

Generally temperature has an influence on the kinetics of the corrosion process and the corrosion products formed. In the BMA vault the variation in temperature is only expected to be a few degrees during the first thousand years and the influence is judged to be of minor importance. However, for longer time periods the development of permafrost and glacial conditions can result in freezing of water and thereby indirectly via hydrological variables limit the corrosion.

Table 5-17. Direct dependencies between the process Metal corrosion and the BMA system component variables and a short note on the handling in SR-PSU.

Variable	Variable influence on process		Process influence on variable	
	Influence present? Yes/No Description	Handling of influence How/If not – Why	Influence present? Yes/No Description	Handling of influence How/If not – Why
Geometry	Yes, dimensions will influence the extent of corrosion.	Considered in modelling of corrosion.	Yes, consumption of metal and formation of corrosion products with larger volume.	Decrease in porosity of surrounding material and risk of concrete fractures induced by corrosion products considered.
Temperature	Yes, influence on mechanism, rate and corrosion products.	Considered in the selection of corrosion rates. Impact of changed temperature negligible – except for glaciation and permafrost.	Yes, but negligible heat generation due to slow corrosion rates.	Not considered.
Hydrological variables	Yes, inflow of water and degree of saturation influence mechanism and rate of corrosion.	Considered in modelling of corrosion.	No, but the degree of saturation and displacement of water is influenced indirectly via gas variables.	Considered in gas transport modelling.
Mechanical stresses	No, no direct influence.		Yes, formation of corrosion products with larger volume.	Considered in mechanical processes causing barrier degradation, see Section 5.3.1.
Material composition	Yes, type of material will influence mechanism and rate of corrosion.	Considered in the selection of corrosion rates.	Yes, consumption of metal and formation of corrosion products.	Corrosion products not considered in selection of sorption properties.
Water composition	Yes, corrosion mechanism, -rates and -products.	Considered in the selection of corrosion rates.	Yes, precipitation and dissolution of corrosion products.	Considered in geochemical modelling.
Gas variables	No, but gas composition and pressure influence the mechanism and rate of corrosion indirectly via water composition.	Initially oxygen provides aerobic conditions - considered in modelling of corrosion and gas formation.	Yes, consumption of O ₂ and generation of H ₂ .	Considered in modelling of corrosion and gas formation.

Influence on temperature

The steel corrosion of reinforcement bars in concrete structures, rock reinforcement and rock bolts is slow and judged to be of negligible importance for the temperature evolution in the vault. Any heat exchange resulting from the slow corrosion processes will be levelled out by heat dissipation through conduction.

Influence by hydrological variables

The inflow of groundwater will determine the evolution of saturated conditions in different parts of the vault and influences thereby the starting point for anaerobic corrosion. The lithostatic pressure (including groundwater pressure) determines the dissolution of gas and influences thereby the saturation degree. The supply of water will not be the limiting factor for hydrogen evolving corrosion.

Influence on hydrological variables

The generated gas will initially dissolve in the pore water. Once the solubility of gas is exceeded, further gas generation will lead to the formation of a gas phase and thereby indirectly via gas variables influence the saturation degree in the vault. If the gas transport capacity is not sufficient the gas pressure will continue to increase until open passages for gas are formed in fractures or pores of the barriers.

Influence by mechanical stresses

Mechanical stresses influence corrosion indirectly by the formation of fissures/crevices in reinforcement bars and rock bolts. The extent of such corrosion processes is judged to be insignificant in comparison with the general corrosion under anaerobic conditions.

Influence on mechanical stresses

The formation of corrosion products increases the volume of the reinforcement bars in the concrete structures and the rock bolts in the rock walls. This process and the reduction in mechanical strength can cause crack formation in the concrete structures leading to preferential flow paths. In the rock walls the corrosion of rock bolts may cause mechanical stresses leading to rock fall-out.

Influence by material composition

The corrosion resistance differ between different steel types. Reinforcement bars in concrete structures, rock reinforcement and rock bolts are generally made in carbon steel and that is considered in the selection of corrosion rates.

Influence on material composition

When steel corrodes under aerobic and anaerobic conditions the material will be consumed. Solid corrosion products (oxides and hydroxides) form on the surface that limits the rate of further corrosion (passivating layer e.g. magnetite). The formed corrosion products may affect sorption properties.

Influence by water composition

The corrosion rate is strongly influenced by the pH and the water composition. The water surrounding the reinforcement bars in concrete structures will be concrete pore water with high pH. For rock reinforcement and rock bolts the water composition will be a mixture of cement matrix porewater and intruding groundwater. The water composition is considered in the selection of corrosion rates.

Influence on water composition

Aerobic corrosion will consume dissolved oxygen in the water. Anaerobic corrosion of the steel components will lead to the formation of dissolved H_2 , Fe(II) and other corrosion products may affect the water composition.

Influence by gas variables

Initially, the presence of oxygen means that aerobic corrosion processes prevail. After establishing anaerobic conditions with hydrogen evolving corrosion, an increased gas pressure may indirectly via water composition limit the hydrogen evolving corrosion process. Hydrogen overpressures up to 100 atmospheres have, however, been shown to have no significant effect on the corrosion rate or the corrosion potential (Smart et al. 2001).

Influence on gas variables

Hydrogen evolving corrosion of reinforcement bars in concrete structures, rock reinforcement and rock bolts will directly contribute to the total gas formed and the gas composition in BMA. However, the major source of gas in BMA is the waste packages (Moreno et al. 2001).

Boundary conditions

Conditions that have an influence on the corrosion process are given below:

- The void volume and the porosity of barrier materials determine the initial amount of oxygen that can be entrapped in the vault.
- The groundwater inflow to the vault from the surrounding rock will determine the time it takes to establish saturated conditions.
- The composition of intruding groundwater will influence the water composition in voids and the pore water composition in barrier materials.

- The release of dissolved species and gases from the waste packages influences the environmental conditions in voids and barriers.
- The gas transport capacity in the surrounding rock and plugs influences the build-up of gas pressure in the vault.

Model studies/experimental studies

In radioactive waste repositories, hydrogen evolving corrosion of metals is one of the main sources for gas formation. Significant modelling and experimental efforts have been spent in national and international programmes on the corrosion of steel in a repository environment (Rodwell et al. 1999).

Gas related processes in the SFR repository, including estimates of metal corrosion, were investigated in the SAFE project (Moreno et al. 2001). In this report corrosion mechanisms of iron and steel for different repository conditions and available data on corrosion rates are presented.

Natural analogues/observations in nature

A review of natural analogues for corrosion of iron materials was made for the safety assessment SR-Site and reported in the Fuel and canister process report, Section 3.5.1 Corrosion of cast iron insert (SKB 2010c).

Time perspective

The inflow of groundwater is expected to fill voids and saturate barrier materials in the vault fairly rapidly. Initially, anaerobic conditions will prevail in the vault, but after some tens of years the dissolved oxygen in the groundwater will be consumed and anaerobic conditions will be established (Moreno et al. 2001). The main corrosion mechanism for reinforcement bars in the concrete structures, rock reinforcement and rock bolts will thereafter be anaerobic corrosion.

Handling in the safety assessment SR-PSU

The metal corrosion of reinforcement bars in concrete structures, rock reinforcements and rock bolts is considered in the safety assessment in terms of:

- Evolution of redox conditions.
- Contribution to gas formation in the vault.
- Degradation of concrete structures (e.g. decrease in mechanical strength and possible crack formation).

The sorption capacity of reinforced concrete structures is not assumed to be enhanced by the formation of corrosion products.

Handling of uncertainties in SR-PSU

Uncertainties in mechanistic understanding:

There are no major uncertainties in the understanding of the corrosion mechanisms for carbon steel under aerobic and anaerobic conditions.

Model simplification uncertainties:

- The consumption of metals under aerobic conditions is neglected.
- Assumption of uniform anaerobic conditions at repository closure and that all surfaces are available for corrosion.
- Uniform corrosion – localised corrosion neglected.
- Constant corrosion rate – passivating layers or build up of corrosion products neglected.
- Magnetite is assumed to be the end-product of corrosion giving the highest yield for gas formation.

Input data and data uncertainties:

- The amounts and dimensions of corroding materials are relatively well known.
- The main uncertainty is the corrosion rate for carbon steel in the repository environment. The uncertainties in steel corrosion rates for SFR repository conditions are discussed in the **Data report**.

Adequacy of references supporting the handling in SR-PSU

The references are judged to be adequate and sufficient to support the handling in SR-PSU. All supporting references are either peer-reviewed articles or documents which have undergone factual review.

Other references have been used for general background information, and not all of these have been peer-reviewed to the same standard.

5.4.10 Gas formation

Gas formation is important within the BMA barriers as it will increase the pressure of the system once the saturation limit of the water phase is reached, i.e. when no further gas can be dissolved. Elevated pressure could lead to gas transport through the barrier, see Section 5.2.3 or, if the gas is trapped, enhanced transport of contaminated water, see Section 5.4.1. The waste and the waste packaging are the main source of metal and organic materials for all gas formation processes in IBMA (Moreno et al. 2001). The different chemical processes causing gas formation in the waste packages are described in the **Waste process report**, section Gas formation. In BMA hydrogen evolving corrosion of the reinforcement bars in the concrete structures will contribute marginally to the total gas formation (Moreno et al. 2001). Metal corrosion in BMA barriers is described in more detail in Section 5.4.9.

Other potential sources of gas are through microbial degradation of organic material and radiolysis of water. Microbial degradation in BMA barriers is described in more detail in Section 5.4.8.

Overview/general description

A general description of gas formation by hydrogen evolving corrosion of metals, microbial degradation of organic materials and radiolytic decomposition of water is given below.

Hydrogen evolving corrosion

Initially steel corrosion will be an aerobic, non-gas generating process; the repository will fill with water after closure, and air present in the vault will dissolve in the intruding water. However, as corrosion consumes the available oxygen, the system will become anaerobic. The stoichiometric relationship between iron corrosion and hydrogen evolution can be approximated using the chemical formula (5-10), which uses magnetite as the end product.

**Microbial degradation**

In brief, aerobic respiration of organic materials consumes oxygen and generates CO₂ on an equal molar basis, while anaerobic respiration generates a mixture of CO₂, H₂ and CH₄ (with a net increase of the gas volume), through the wide variety of metabolic pathways available, see Section 5.4.8. Gas production will clearly be affected by the viability of different microbial species under the evolving conditions and the availability of substrates for metabolic pathways and, therefore, the gases formed will be influenced by the chemical conditions.

Radiolytic decomposition

Radiolysis of water generates hydrogen and oxygen gases. However, the radiation field in the SFR repository is relatively low and the predicted gas formation even in the wastes is negligible in comparison with the gas formation from metal corrosion (Moreno et al. 2001). Radiolytic decomposition in the waste is described in more detail in the **Waste process report**.

Dependencies between process and system component variables

Table 5-18 shows how gas formation in the BMA system is influenced by the specified set of physical variables and how the process influences the variables. In addition, the handling of each influence in SR-PSU is indicated in the table and more thoroughly discussed in the text below. In BMA the main source for gas formation is metal corrosion. The table below is therefore focused on dependencies between gas formed by hydrogen evolving corrosion and the system component variables.

Table 5-18. Direct dependencies between the process gas formation and the BMA system component variables.

Variable	Variable influence on process		Process influence on variable	
	Influence present? Yes/No	Description	Influence present? Yes/No	Description
Geometry	Yes	dimensions will influence the gas formation rate.	No	only an indirect influence via pressure build-up.
Temperature	Yes	influence on gas formation rate.	No	but indirectly via metal corrosion.
Hydrological variables	Yes	initial inflow of water and degree of saturation influence the gas formation rate.	Yes	affects the degree of saturation once the solubility limit for the gas in the surrounding water is exceeded.
Mechanical stresses	No		No	only an indirect influence via gas variables in terms of pressure build-up.
Material composition	Yes	type of material will influence the gas formation rate.	No	but indirectly via metal corrosion.
Water composition	Yes	influence on gas formation rate and corrosion products.	No	but indirectly via metal corrosion that consumes dissolved oxygen, see Section 5.4.9.
Gas variables	Yes	gas composition and pressure influence gas formation rate.	Yes	formation of gaseous H ₂ and pressure build-up.

Influence by geometry

Yes, a direct influence has been identified.

The dimensions (thickness and surface area) of the reinforcement bars in the concrete structures and the dimensions of rock bolts and reinforcement in shotcrete will affect the gas formation rate. In addition, the properties of the materials protecting the iron components such as thickness of protecting layers and material porosity will have an influence on the corrosion process.

Influence on geometry

No direct influence has been identified.

The hydrogen evolving corrosion of steel components embedded in concrete or shotcrete will influence the geometry indirectly through an increase in pressure if the gas accumulates and leads to fracture formation, see Section 5.2.3.

Influence by temperature

Yes, a direct influence has been identified.

Generally temperature has an influence on the kinetics of the corrosion process and the corrosion products formed. In the vault the variation in temperature is only expected to be a few degrees during the first thousand years and the influence of minor importance. However, for longer time periods the development of permafrost and glacial conditions can result in freezing of water and thereby limit the gas formation rate indirectly via hydrological variables.

Influence on temperature

No direct influence has been identified.

Influence by hydrological variables

Yes, a direct influence has been identified.

The inflow of groundwater will determine the evolution of saturated conditions in different parts of the vault and influences thereby the initiation of hydrogen evolving corrosion. The supply of water will not be the limiting factor for the gas formation process. A change in aggregation state of the water may limit gas formation as water is less available.

Influence on hydrological variables

Yes, a direct influence has been identified.

The formation of gas will lead to the formation of a gaseous phase when the solubility in the surrounding water is exceeded and may therefore influence the degree of saturation in the vault. If the gas transport capacity is not sufficient the gas pressure will increase, eventually creating open passages for gas transport and thereby cause displacement of water, see Section 5.2.3.

Influence by mechanical stresses

No direct influence has been identified.

Influence on mechanical stresses

No direct influence has been identified.

Gas formation will influence the mechanical stress indirectly if the gas accumulates and the gas pressure increases, see Section 5.2.3.

Influence by material composition

Yes, a direct influence has been identified.

The corrosion resistance differs between different steel types. Reinforcement bars in concrete structures, rock reinforcement and rock bolts are generally made in carbon steel and this is considered in the selection of gas formation rates.

Influence on material composition

No direct influence has been identified.

Hydrogen evolving corrosion is accompanied by solid corrosion products (oxides and hydroxides) formed on the surface that limit the rate of further corrosion (passivating layer e.g. magnetite), see Section 5.4.9.

Influence by water composition

Yes, a direct influence has been identified.

The gas formation rate is strongly influenced by the pH and the water composition. The water surrounding the reinforcement bars in concrete structures will be concrete pore water with high pH, which

leads to a lower gas formation rate. For rock reinforcement and rock bolts the water composition will be a mixture of cement matrix porewater and intruding groundwater, see Section 5.4.7.

Influence on water composition

No direct influence has been identified.

Indirectly, dissolved oxygen in the water will be consumed by anaerobic corrosion and the corrosion of the steel components will lead to the formation of corrosion products that alter the water composition, see Section 5.4.9. The dissolution of formed H_2 (anaerobic conditions) and Fe(II) is essential for the development of reducing conditions in the water in the vault. The microbial activity may be stimulated by the presence of hydrogen, see Section 5.4.8.

Influence by gas variables

Yes, a direct influence has been identified.

An increased gas pressure may limit the hydrogen evolving corrosion process. Hydrogen overpressures up to 100 atmospheres have, however, been shown to have no significant effect on the corrosion rate or the corrosion potential (Smart et al. 2001).

Influence on gas variables

Yes, a direct influence has been identified.

Hydrogen evolving corrosion of reinforcement bars in concrete structures, rock reinforcement and rock bolts will contribute to the total gas formation and the gas composition in BMA as well as the pressure and degree of saturation. However, the major source for gas formation in BMA is the waste packages (Moreno et al. 2001).

Boundary conditions

Conditions that have an influence on gas formation by hydrogen evolving corrosion are given below:

- The void volume and the porosity of barrier materials determine the initial amount of oxygen that can be entrapped in the vault.
- The groundwater inflow from the surrounding rock will determine the time it takes to establish saturated conditions.
- The groundwater composition will influence the water composition especially around the rock reinforcement.
- The release of dissolved species and gases from the waste packages influences the environmental conditions in voids and barriers.
- The gas released from the waste packages has major influence on the build-up of gas pressure in the vault.
- The gas transport capacity in surrounding rock and the plug influences the build-up of gas pressure in the vault.

Model studies/experimental studies

Hydrogen evolving corrosion of metals is one of the main gas formation processes in radioactive waste repositories. Significant modelling and experimental efforts have been spent in national and international programmes on the corrosion of steel in a repository environment (Rodwell et al. 1999).

Gas related processes in the SFR repository were investigated in the SAFE project (Moreno et al. 2001). In the report the contribution from hydrogen evolving corrosion, microbial degradation and radiolysis to gas formation rates and gas volumes in the different repository parts was estimated. In addition, gas transport mechanisms and the potential impact on radionuclide release were presented.

Natural analogues/observations in nature

As mentioned in Miller et al. (2000), natural analogues for gas generation have not been studied. The processes in nature are poorly quantified. Although natural or anthropogenic analogues for metal corrosion processes can be found, the associated gas generation is very difficult to quantify. The same occurs with generation of gases due to organic degradation processes. In the last years increasing effort has been devoted to the study of CO₂ capture and sequestration, and it is very likely that these studies can provide insights for gas generation processes and their chemical interactions with different media.

Time perspective

The inflow of groundwater is expected to fill voids and saturate barrier materials in the vault fairly rapidly. Initially anaerobic conditions will prevail in the vault but after some tens of years the dissolved oxygen in the groundwater will be consumed and anaerobic conditions established. The main corrosion mechanism for reinforcement bars in the concrete structures, rock reinforcement and rock bolts will be hydrogen evolving corrosion during the repository life time.

Handling in the safety assessment SR-PSU

In the safety assessment SR-PSU, gas is considered to form solely as a result of hydrogen-evolving corrosion in the BMA barriers. This involves corrosion of reinforcement bars in concrete structures, rock reinforcement and rock bolts, and is considered to start instantaneously. Microbial degradation processes in the barriers are considered to make a negligible contribution to the gas formed.

Handling of uncertainties in SR-PSU

A summary of the uncertainties related to gas formation and migration in performance assessment exercises is given in Norris (2008) and a presentation on how the gas-related processes is handled in different performance assessments can be found in Norris (2009).

Uncertainties in mechanistic understanding:

There are no major uncertainties in the understanding of mechanisms for hydrogen evolving corrosion of carbon steel.

Model simplification uncertainties:

- The consumption of metals under aerobic conditions is neglected.
- Uniform assumption of anaerobic conditions at repository closure and that all surfaces are available for corrosion. This means that gas formation starts instantaneously in the whole vault.
- Constant gas formation rate – passivating layers or build up of corrosion products neglected
- Magnetite is assumed to be the end corrosion product giving the highest yield for gas formation.

Input data and data uncertainties:

- The amounts and dimensions of corroding materials are relatively well known.
- The main uncertainty is the rate for hydrogen evolving corrosion of carbon steel in the repository environment. The uncertainties in steel corrosion rates for SFR repository conditions are discussed in the **Data report**.

Adequacy of references supporting the handling in SR-PSU

The references are judged to be adequate and sufficient to support the handling in SR-PSU. All supporting references are either peer-reviewed articles or documents which have undergone factual review. Other references have been used for general background information, and not all of these have been peer-reviewed to the same standard.

5.5 Radionuclide transport

5.5.1 Speciation of radionuclides

Overview/general description

This process describes the speciation of radionuclides; i.e. the establishment of all chemical equilibria determining the thermodynamically (and kinetically) stable chemical forms of radionuclides in pore solutions. In addition to typical reactions in solutions, these equilibria include redox reactions as well as the formation of radionuclide solid phases and sorbed species. The latter is addressed separately under the process sorption (Sections 5.4.3 and 5.4.4).

Speciation of radionuclides considers the formation of solubility-limiting solids as well as directly affects sorption and diffusion processes. In turn, speciation depends on the chemical conditions and concentrations of specific reactants in the cement/concrete and sand/gravel components.

Dependencies between processes and barrier variables

Table 5-19 shows how speciation of radionuclides in the BMA system is influenced by the specified set of physical variables and how the process influences the variables. In addition, the handling of each influence in SR-PSU is indicated in the table and more thoroughly discussed in the text below.

Temperature The effect of temperature on aqueous speciation is relatively well understood and can be handled (within the relatively narrow range expected for the repository) by speciation models. The effect on solubility can be more difficult to predict, especially in cases where the nature of potentially forming solid phases changes within the relevant temperature range. For effects on sorption, see Section 5.4.3.

Table 5-19. Direct dependencies between the process ‘speciation of radionuclides’ and system component variables and a short note on the handling in SR-PSU.

Variable	Variable influence on process		Process influence on variable		
	Influence present? Yes/No	Description	Influence present? Yes/No	Description	
Geometry	No.	Speciation is a molecular-level chemical process which is not influenced by macroscopic geometry.	–	–	
Temperature	Yes.	Temperature will have an effect on speciation.	Effect on equilibria is considered in speciation models using thermodynamic data or approximations.	No.	–
Hydrological variables (pressure and flows)	No.	(no direct influence on speciation).	–	No.	–
Mechanical stresses	No.		–	No.	–
Material composition	Indirectly through	porewater composition.	See water composition.	No.	–
Water composition	Yes.	Water composition directly affects speciation.	Water composition considered in speciation modelling.	Yes. Speciation effects the chemical form of the dissolved radionuclides and in that sense water composition. However, radionuclide concentrations are at trace levels and do not influence bulk water composition.	Included in speciation modelling.
Gas variables	Indirectly by influencing	water composition.	See water composition.	No.	Not considered.
				Radionuclides are present only at trace concentrations, their aqueous speciation does not influence bulk gas composition.	

Water composition is the main factor influencing speciation. Therefore, other variables that influence water composition (such as the composition of solids and gas) will also indirectly have an effect on radionuclide speciation. By influencing sorption and solubility, water composition influences radionuclide concentration. On the other hand, trace concentrations of radionuclides entering the barrier system will not have a notable effect on bulk properties.

Boundary conditions

The relevant boundary conditions in order to treat the process quantitatively are those of the transport processes that control the exchange of solutes with adjacent components, i.e. the boundary conditions of the processes diffusion and advection/dispersion).

Model studies/experimental studies

Most of the relevant aqueous equilibria involving radionuclides have been studied in detail, and corresponding equilibrium constants are available (see Guillaumont et al. 2003 as an example). Given that the water chemistry is known, the speciation of radionuclides can therefore be calculated with a thermodynamic equilibrium model, such as PHREEQC (Parkhurst and Appelo 1999).

Natural analogues/observations in nature

The speciation of many trace elements has been studied experimentally and predicted by thermodynamic models in a wide range of natural waters (see e.g. Stumm and Morgan 1996, and references therein). Natural analogue studies in the context of radioactive waste disposal are typically not aimed at the aqueous phase as such but focus more on solid/liquid speciation and solubility. Bruno et al. (2002) reviewed thermodynamic modelling exercises related to the prediction of solubility and speciation of trace elements at natural analog sites. While this allowed valuable insights regarding the solubility control of various relevant trace elements, it is also pointed out that lacking in situ speciation data in case of most natural analog studies hampers comparisons between predicted and actual aqueous speciation.

Time perspective

This process is relevant for the whole assessment period. It can be considered fast in comparison to transport processes; i.e. local equilibrium can be assumed.

Handling in the safety assessment SR-PSU

This process is only relevant after saturation and in case of a release of radionuclides.

The speciation of radionuclides is calculated based on thermodynamic data (i.e. equilibrium assumption) and could be used to define solubility limits where relevant. For the SR-PSU safety assessment, no solubility limits are considered, however.

Radionuclide speciation is used to assess their transport properties in the barrier. In case of cement-based materials there is a high degree of similarity between expected conditions and those in laboratory experiments. Therefore, a qualitative representation of speciation (in particular of hydrolysis at high pH) is deemed sufficient.

Handling of uncertainties in SR-PSU

Uncertainties in mechanistic understanding

The basic understanding of the process is well developed. In cases of some radionuclides, there are still uncertainties in understanding their interaction with certain ligands (e.g. dissolved silica, mixed hydroxo-carbonato complexes, ISA), especially at high pH.

There are also fundamental uncertainties regarding the nature and stability of complex solid phases that many radionuclides may form (or partition into) in cementitious systems. Neglecting such solids in solubility calculations and considering only simple radionuclide solids can lead to an overestimation of solubility.

Model simplifications uncertainties

Calculated solubility limits are valid for the underlying set of chemical conditions. Due to the buffering effect of the hydrated cement, it can be assumed that conditions are fairly well constrained.

Input data and data uncertainties

Input data to quantitatively describing the process are thermodynamic data and water compositions. The uncertainty of thermodynamic data (or of the calculations) can be estimated. Uncertainties in water composition can be handled by considering bounding conditions.

Input data are solubility limits for radionuclides that can be used directly in consequence calculations. Their uncertainties can be estimated. For sorption, which is also closely linked to speciation, see Section 5.4.3.

5.5.2 Transport of radionuclides in the water phase

Overview/general description

Several processes that may affect radionuclide transport have been identified. However, most of these have already been discussed above under other processes occurring in the BMA. The main radionuclide transport related processes in the barriers, and references to where they are discussed in more details, are identified as follows:

- Advection (see Sections 5.2.2 and 5.4.1).
- Diffusion (Section 5.4.2).
- Dispersion (Section 5.4.1).
- Sorption (see Sections 5.4.3 and 5.4.4).
- Speciation (Section 5.5.1).
- Colloid transport (see Section 5.4.5).
- Radioactive decay and ingrowth (discussed in the **Waste process report**).

Dependencies between process and system component variables

Table 5-20 shows how transport of radionuclides in the water phase in the BMA system is influenced by the specified set of physical variables and how the process influences the variables.

Boundary conditions

The inner boundary for the radionuclide transport processes is the concentration of nuclides in the interior of the BMA repository. The outer boundary is the concentration in the rock outside the repository (assumed to be a zero concentration boundary condition).

Model studies/experimental studies

Radionuclide transport through the barriers in SFR has been studied in several earlier safety assessments (Wiborgh et al. 1987, Lindgren et al. 2001, Thomson et al. 2008b). The conclusions from these studies are that the barrier system of the present SFR repository is sufficient for its purpose, although the release of some weakly sorbing nuclides e.g. C-14 has not yet been proven to be small enough to give a good margin for the resulting doses compared to the dose limits provided by the authorities.

Natural analogues/observations in nature

Not applicable since this process cover the integrated treatment of radionuclide transport in the near field.

Table 5-20. Direct dependencies between “Transport of radionuclides in the water phase” and system component variables and a short note on the handling in SR-PSU.

Variable	Variable influence on process		Process influence on variable	
	Influence present? Yes/No Description	Handling of influence How/If not – Why	Influence present? Yes/No Description	Handling of influence How/If not – Why
Geometry	Yes. Gives the volumes and areas available for transport	Yes. Geometry variables are included in RN-transport model	No.	–
Temperature	Yes.	No. Effects are negligible. (see note 1 below)	No.	–
Hydrological variables	Yes. Water fluxes are highly significant for advective transport of RN.	Yes. Detailed flow parameters are included in the RN model.	No.	–
Mechanical stresses	No.	–	No.	–
Material composition	Yes. Sorption properties are highly dependent on material composition.	Yes. Material specific K_d values are included in the RN model.	No.	–
Water composition	Yes. Sorption properties are dependent on water composition.	Yes. Considered in the selection of K_d data.	Yes.	The porewater concentration of radionuclides in all parts of the system is calculated.
Gas variables	No. (see note 2 below)	–	No.	–

Note 1: The influence of the temperature variable is assumed to be negligible during temperate conditions. During permafrost conditions, with freezing down to repository depth, advective and diffusive transport processes are assumed to be inhibited. This freezing effect is included in the modelling.

Note 2: The gas variables do not directly influence radionuclide transport. However gas variables can indirectly influence radionuclide transport via gas driven advection. Such situations are handled in separate calculation cases in the radionuclide transport modelling.

Time perspective

Transport of radionuclides in the water phase will be relevant at all time scales in SFR.

Handling in the safety assessment SR-PSU

Radionuclide transport in the barriers is included in a radionuclide transport model of the whole repository system (**Radionuclide transport report**), modelled with the Ecolego code (**Model summary report**). Ecolego is a compartment based simulation code with the possibility to model large systems of connected compartments. The radionuclide transport model comprises the waste matrix, the engineered barriers, the geosphere and the biosphere. Below are short descriptions on how the radionuclide transport processes listed in the beginning of this section are treated in the assessment.

Advection

Advection is explicitly included in the radionuclide transport modelling. However the calculation of water fluxes are performed in a calculation step separated from the radionuclide transport calculations. These hydrological calculations are performed with the code Comsol Multiphysics (Abarca et al. 2013). The output from the hydrological calculations are a detailed set of water fluxes over surfaces of interest for the radionuclide modelling. These water fluxes are propagated as parameters to the radionuclide transport calculations and used together with volumes and sorption data for barrier parts, to calculate the retention and advective transport of solved radionuclides.

As the waterfluxes are calculated for various degradation states, the modelling implicitly takes into account the expected degradation of the barriers over time. For the BMA repository parts the possible future occurrence of larger fractures is modelled explicitly by an advective transport directly through the barriers, without taking into account the sorption in the barriers.

Diffusion

Diffusion is explicitly included in the modelling. The calculation takes into account the media specific effective diffusivities as well as the porosities and geometries (transport lengths and cross section areas) of the barriers. The diffusion coefficients are increased over time to describe a gradual degradation of the barriers.

Dispersion

Dispersion is not handled explicitly in the modelling since the chosen modelling approach introduces greater numerical dispersion than the expected physical dispersion, hence there is no need for a specific dispersion term.

Sorption

Sorption has a retarding effect on both advective and diffusive transport of solutes. Sorption on barrier materials is explicitly included in the radionuclide transport modelling using a linear approach, based on element-specific K_d values.

Speciation

Speciation of radionuclides is directly included in the calculation of the source term from the inner boundary condition. The speciation is also included in the determination of the sorption coefficients.

Colloid transport

Effects of colloid facilitated transport are considered negligible, due to the low concentration of colloids expected.

Radioactive decay and in-growth

Radioactive decay and in-growth are well known physical processes with a very exact mathematical description (Krane 1987), which makes the modelling straightforward. These processes are explicitly included in the modelling by means of the decay constants λ .

Handling of uncertainties in SR-PSU

Uncertainties in mechanistic understanding:

The transport of radionuclides is dependent on several physical and chemical processes described elsewhere in this document. The uncertainties in understanding of these processes will of course affect the uncertainties in the radionuclide transport modelling. However, the processes of most significance for the radionuclide transport are well understood (see Sections 5.4.1 and 5.4.2).

Model simplification uncertainties:

The following list contains some of the uncertainties related to model simplifications:

- The radionuclide transport calculations for the barriers are made with a compartment modelling approach. The different parts of the barrier system are discretised into a set of connected compartments, which can be described by a set of coupled ordinary differential equations. For practical reasons the chosen discretisation has to be relatively coarse. Especially for highly sorbing nuclides this can lead to relatively large errors in the estimation of the release. Arrangements for various conservative approaches, to avoid an underestimation of the releases at any point in time because of this, have been made in the modelling. (**Radionuclide transport report**).
- The relatively coarse discretisation of the model also introduces numerical dispersion. The effect of this dispersion is larger than the real (physical) dispersion process. Hence the dispersion process is not included in the modelling of transport through the barriers.
- All chemical properties are not represented in detail in the transport model. Instead a simplified methodology is applied, where retardation of nuclides is described with a linear K_d approach.
- In the calculations the repository is assumed to be resaturated when calculation starts. Hence the initial transport of nuclides during resaturation is not represented in the modelling.

Input data and data uncertainties:

Input data are described in detail in the **Data report**.

The uncertainties in parameter data are handled by means of probabilistic simulations and pessimistic assumptions. The uncertainties of the parameters are expressed with probability density functions, used in Monte Carlo simulations.

Adequacy of references supporting the handling in SR-PSU

The Ecolego code (**Model summary report**) has been verified against the Amber code used in previous assessments for SFR, using the same near field models as used in SAR-08 (SKB 2008b). The results from the Ecolego models showed good agreement with the results obtained with Amber. No other discrepancies than small deviations that can be expected due to the use of different numerical methods were found. (**Radionuclide transport report**).

5.5.3 Transport of radionuclides in the gas phase

Overview/general description

Gas containing radionuclides such as C-14, H-3 and Rn-222 can be released in the waste domain and be transported through the barrier system in gas phase (**Waste process report**).

The gas is assumed to escape through gaps and fractures in the concrete barriers and eventually escapes to the surface more rapidly than radionuclides in the water phase. (Moreno et al. 2001).

Dependencies between process and system component variables

Table 5-21 shows how transport of radionuclides in the gas phase in the BMA system is influenced by the specified set of physical variables and how the process influences the variables.

Boundary conditions

The inner boundary for this process is the gas pressure inside the repository. The outer boundary is the fractures in the rock where the gas is assumed to escape rapidly to the surface.

Model studies/experimental studies

A study by NIREX (Nirex 2003) takes into consideration generation and migration of radionuclides in the gas phase. This study concludes that the risk from the gas pathway is dominated by C-14. This conclusion is also likely to be relevant for the extended SFR.

Table 5-21. Dependencies between “Transport of radionuclides in the gas phase” and system component variables.

Variable	Variable influence on process		Process influence on variable	
	Influence present? Yes/No	Handling of influence Description How/If not – Why	Influence present? Yes/No	Handling of influence Description How/If not – Why
Geometry	Yes.	See note 1 below.	No.	–
Temperature	Yes.	See note 1 below.	No.	–
Hydrological variables	No.	–	No.	–
Mechanical stresses	No.	–	No.	–
Material composition	Yes.	See note 1 below.	No.	–
Water composition	Yes.	See note 1 below.	Yes.	No. Negligible.
Gas variables	Yes.	See note 1 below.	Yes.	See note 1 below.

Note 1: Transport in gas phase is not explicitly included in the modelling of radionuclide transport in waste and barriers. Instead radionuclides released in the gas phase are assumed to reach the surface system immediately when released.

Natural analogues/observations in nature

Not relevant.

Time perspective

Gas release is assumed to be possible during a period of several thousand years after closure of the repository (Moreno et al. 2001).

Handling in the safety assessment SR-PSU

Radionuclide transport in the gas phase is not explicitly included in the radionuclide transport modelling in SR-PSU. Escape of radionuclides in gas phase is not considered when modelling radionuclide transport in the aqueous phase; hence the whole radionuclide inventory is in the modelling available for transport in the aqueous phase, in most calculation cases.

For calculation cases where significant amounts of radionuclides are assumed to be released in the gase phase, the whole release is assumed to reach the surface system (Biosphere) directly, i.e. at the same rate as gas is generated in the repository.

Handling of uncertainties in SR-PSU

See previous section.

Adequacy of references supporting the handling in SR-PSU

See Section 5.5.2.

6 1BTF and 2BTF

6.1 Thermal processes

6.1.1 Heat transport

Overview/general description

The heat transport process is described in the corresponding section for the BMA repository (Section 5.1.1 This description also applies here).

Dependencies between process and system component variables

Table 6-1 shows how the process influences, and is influenced by, all system variables.

Table 6-1. Direct dependencies between the process “Heat transport” and the defined system variables and a short note on the handling in SR-PSU.

Variable	Variable influence on process		Process influence on variable	
	Influence present? Yes/No Description	Handling of influence How/If not – Why	Influence present? Yes/No Description	Handling of influence How/If not – Why
Geometry	Yes, the constitution of the system determine how heat flows.	The process is not explicitly handled. See Section 5.1.1.	No.	
Temperature	Yes. Temperature differences is a requirement for the process.	The process is not explicitly handled. See Section 5.1.1.	Yes. Heat transport tends to even out temperature differences.	The process is not explicitly handled. See Section 5.1.1.
Hydrological variables	Yes. Water flow may transport heat. Heat capacities may change with saturation state and aggregation state.	The process is not explicitly handled. See Section 5.1.1.	Yes, through e.g. convection. The influence is however negligible because temperature differences are small.	The process is not explicitly handled. See Section 5.1.1.
Mechanical stresses	Yes, in principle as e.g. heat capacities may depend on stress state. The effect is however negligible.	The process is not explicitly handled. See Section 5.1.1.	Yes. Due to thermal expansion/contraction.	The process is not explicitly handled. See Section 5.1.1.
Material composition	Yes. Different materials have different thermal conductivities, specific heats etc.	The process is not explicitly handled. See Section 5.1.1.	No.	
Water composition	Yes in principle as e.g. heat capacities may depend on composition. The effect is however negligible.	The process is not explicitly handled. See Section 5.1.1.	No.	
Gas variables	Yes. Gas flow may transport heat.	The process is not explicitly handled. See Section 5.1.1.	Yes, but relevant only during the operational phase when the repository is not water saturated.	The process is not explicitly handled. See Section 5.1.1.

Boundary conditions

See Section 5.1.1

Model studies/experimental studies

See Section 5.1.1.

Natural analogues/observations in nature

See Section 5.1.1

Time perspective

See Section 5.1.1

Handling in the safety assessment SR-PSU

See Section 5.1.1

Handling of uncertainties in SR-PSU

See Section 5.1.1.

6.1.2 Phase changes/freezing

The description made for the BMA repository (Section 5.1.2 applies also here.

Dependencies between process and system component variables

Table 6-2 shows how the process influences, and is influenced by, all system variables.

Boundary conditions

See Section 5.1.2.

Model studies/experimental studies

See Section 5.1.2.

Natural analogues/observations in nature

See Section 5.1.2.

Time perspective

See Section 5.1.2.

Handling in the safety assessment SR-PSU

See Section 5.1.2.

Handling of uncertainties in SR-PSU

See Section 5.1.2.

References

See Section 5.1.2.

Table 6-2. Direct dependencies between the process “Phase changes/freezing” and the defined system variables and a short note on the handling in SR-PSU.

Variable	Variable influence on process		Process influence on variable	
	Influence present? Yes/No Description	Handling of influence How/If not – Why	Influence present? Yes/No Description	Handling of influence How/If not – Why
Geometry	Yes. Freezing point is influenced by confinement geometry if it is small (sub microns). Frost susceptibility depends on pore geometry.	Freezing points (or temperature intervals) are estimated for each component material.	Yes. Pore geometries may be different after freezing. Fractures may have been created or widened. Cycles of freezing/thawing may cause particle sorting.	Altered hydraulic conductivity after permafrost period.
Temperature	Yes. Freezing occur at a certain temperature or in a certain temperature interval.	Freezing points (or temperature intervals) are estimated.	Yes. Freezing releases energy. Thawing consumes energy.	Neglected as the influence of the repository on temperature evaluation is minor. See also Section 5.1.1.
Hydrological variables (pressure and flows)	Yes. Water pressure has a minor influence on freezing point.	Insignificant, unless very high pressures.	Yes. Freezing may cause pressure increase and affect water flow. Freezing may also reduce conductivity (a completely frozen system does not flow).	The barrier function of concrete is considered lost after a freezing/thawing cycle.
Mechanical stresses	Yes. Pressure influences freezing point.	Insignificant, unless very high pressures involved.	Yes. Freezing and frost heave may induce stresses and strains.	Altered hydraulic conductivity after permafrost period. Effect on host rock is estimated.
Material composition	Yes. Freezing point is influenced by surface properties.	Freezing points (or temperature intervals) are estimated.	No.	
Water composition	Yes. Freezing point is influenced by type and concentration of solutes.	Estimated from water chemistry.	Yes. Freezing may change composition of remaining unfrozen water.	Neglected, because possible freezing is slow in comparison to diffusive and advective mass transfer.
Gas variables	No. Indirectly through dissolved gases.	Insignificant unless gas pressures are high. Handled via water composition.	No.	

6.2 Hydraulic processes

6.2.1 Water uptake and transport during unsaturated conditions

Overview/general description

BTF is similar to BMA, the main difference being that concrete is that concrete grout is used in the space between the walls and the rock instead of sand. The processes are thus similar.

Water transport in porous materials under unsaturated conditions is a complex process that is dependent on, *inter alia*, material composition, temperature, degree of water saturation and water content. The most important driving force for water saturation under SFR conditions is a gradient in water pressure or relative humidity in the pores of the material that follows after water inflow from the surrounding rock. The supply of water from the rock by water transport in fractures and in the rock matrix is also a decisive factor for the temporal evolution of the process.

A detailed description of the process is given in Section 5.2.1 regarding BMA and will not be repeated here.

Water transport in the sand or Macadam filling before saturation is mainly governed by the inflow rate and inflow distribution in the rock. Since the expected hydraulic conductivity of the sand is rather high, the resistance to water inflow into the filling material will be very low. Most processes connected with the general description of unsaturated water flow are not relevant for the sand filling. For example, the suction in the sand is insignificant and the temperature gradient is so low that there is no temperature driven vapour flow. The only relevant processes are A1, A4, A5, E2 and F1, as defined in Section 5.2.1.

If the backfill is made of gravel, macadam or coarse sand the material is self-draining, meaning that water will by gravity sink to the bottom. Otherwise the water will be retained by capillary forces until the sand is close to water saturated.

Water transport in the concrete can take place in two ways. If there are fractures in the concrete, water will easily be transported through the fractures and the same processes will occur as in the sand. Otherwise, water transport in the concrete matrix is very slow due to the small size of the pores. Most processes described in Section 5.2.1 are relevant for water transport in the matrix except for the thermal ones.

If there are no cracks in the concrete and if the joints are water tight, all water that is needed to fill the waste containment must be transported through concrete matrix.

The effect of gas production is treated in Section 5.2.3.

Dependencies between process and system component variables.

Table 6-3 summarises how the process influences and is influenced by all BTF processes and how these effects are handled. In addition, the handling of each influence in SR-PSU is indicated in the table and more thoroughly discussed in the text below.

Boundary conditions

Interaction between backfill and the rock: A key issue for the saturation process is the interaction between rock and backfill. Water is conducted to the backfill mainly in the water-bearing fractures, which means that water saturation can be uneven. However, the high hydraulic conductivity of the backfill will spread the water in the backfill at the same rate as the water inflow. If the backfill is self-draining it will be water filled easily like a bathtub and form a well-defined water boundary to the concrete roof.

Table 6-3. Direct dependencies between the process “Water uptake and transport under unsaturated conditions” in BTF and the defined variables and a short note on the handling.

Variable	Variable influence on process		Process influence on variable	
	Influence present? Yes/No	Description Handling of influence How/If not – Why	Influence present? Yes/No	Description Handling of influence How/If not – Why
Geometry	Yes.	Geometry included in the model.	No.	
Temperature	No, but indirect through water viscosity.	See row water composition.	Yes, wetting and drying effects.	Negligible since the temperature gradients are very small.
Hydrological variables	Yes, basic variables.	Variables in the model.	Yes.	Variable in the model.
Mechanical stresses	Yes.	Variable in the model.	Yes.	Variable in the model.
Material composition	Yes, hydraulic conductivity and retention curve.	Sensitivity analyses.	No, but indirectly through erosion if it takes place.	No erosion is expected since the material is not sensitive to erosion.
Water composition	Yes, mainly through the viscosity.	Negligible since the change in viscosity is small.	No.	
Gas variables	Yes, via gas pressure and degree of saturation.	Variable in the model.	Yes.	Variable in the model.

Interaction between concrete and the rock: The slot between the walls and the rock are grouted with concrete, which will form the boundary with the rock. The water flow through the walls depends on how the fractures in the rock interact with possible cracks in the concrete grout. If there is no connection, the water saturation from the walls will probably be very slow and instead come from the roof.

Interaction between the backfill and the concrete structure: The high hydraulic conductivity of the backfill will spread the water in the backfill at the same rate as the water inflow. If the backfill is self-draining it will be water filled easily like a bathtub and form a well-defined water boundary to the concrete roof.

Interaction with the plugs: The plugs will seal off the BTF vault from the access tunnels and prevent water leakage from the backfill material.

Model studies/experimental studies

There are numerous examples of water flow in concrete structures in engineering practice. Also, backfill type of materials have been investigated and used for engineering purpose in numerous tests and practices. Hence, no studies with explicit purpose to investigate the water flow in BTF like structures have been performed.

Natural analogues/observations in nature

See Section 5.2.1.

Time perspective

The time until full saturation depends very much on the rock conditions and the existence of cracks in the concrete. The process is expected to be rather fast (years) but combinations of tight rock, fracture-free concrete and entrapped air may probably prolong it to a hundred years.

Handling in the safety assessment SR-PSU

The process water uptake and water flow in unsaturated conditions is not important for the safety assessment, unless the time to full saturation is very long (hundreds of years). Since the water inflow rate is high and the permeability of a fractured concrete is also high the time to saturation is expected to be rather short (years?) but may be prolonged if air is entrapped. The risk and consequences of entrapped air will be analysed.

If there are no cracks in the concrete and if the joints are water tight, all water that is needed to fill the waste containment must be transported through the concrete matrix. In this case the time to full water saturation can be long.

Conceptual modelling in order to frame the time it may take to reach full saturation could be done, but is not critical. The concrete in existing vaults is highly cracked (e.g. in BMA). In SAR 08 (SKB 2008b) referring to Holmén and Stigsson (2001) it is assumed that the hydraulic conductivity of the concrete is relatively high (10^{-9} m/s), which would correspond to an average of the cracked concrete. On this basis, the concrete will be considered somewhat cracked in the base case but also the case of undamaged concrete will be analysed. In order to make the modelling easier, a porous media approach will be used.

Timescales: Only the time to reach full water saturation will be analysed.

Boundary conditions: The rock will be used as boundary condition. Different boundary conditions will be analysed.

Handling of variables influencing this process: All the influencing variables in the table, except temperature, will be included in the analyses.

Handling of variables influenced by this process: All the influenced variables except temperature will be included in the analyses.

Handling of uncertainties in SR-PSU

The uncertainties are mainly related to the rock properties and the existence of cracks in the concrete.

Uncertainties in mechanistic understanding: The general understanding of unsaturated flow in backfill and concrete are rather good. The main uncertainties are the properties of the cracks in the concrete.

Model simplification uncertainties: The water flow in the concrete will probably be simplified to assume that there are several cracks that let water flow freely through them and thus that the inner of the concrete structure will be water filled at the same rate as the backfill. Then the matrix of the concrete will be slowly saturated.

Input data and data uncertainties: The extent of cracking and the properties of the concrete are the most uncertain data.

Adequacy of references supporting the handling in SR-PSU

The references are judged to be adequate and sufficient to support the handling in SR-PSU. All supporting references are either peer-reviewed articles or documents which have undergone factual review. Other references have been used for general background information, and not all of these have been peer-reviewed to the same standard.

6.2.2 Water transport under saturated conditions

Overview/general description

Water flow in saturated porous material is a special case of unsaturated flow. The number of processes to consider is fewer (vapour flux, phase transitions and air phases do not exist). Those processes that are involved are essentially the same as for unsaturated conditions, but can vary widely in importance when compared with unsaturated conditions.

The most important mechanism under saturated conditions is transport of water in the liquid phase, which is driven by a water pressure gradient. This transport process can be described by Darcy's Law. Any deviations from Darcy's Law, which can occur at low gradients, are favourable in that they lead to a reduced flow-through rate (e.g. Dixon et al. 1999, Hansbo 1960). The hydraulic conductivity, K , is a function of the material composition, the void ratio, e , and the temperature, T .

The hydraulic conductivity of the sand or gravel backfill is rather high and ranges between 10^{-6} and 10^{-2} m/s depending on the grain size distribution. The hydraulic conductivity of concrete depends very much on the quality of the concrete. If the concrete is free from fractures the hydraulic conductivity may be very low. However, the existence of joints and probable cracks will dominate the hydraulic behaviour. See also Section 5.2.2.

With time the concrete is expected to degrade and the sealing effect will eventually be completely lost. This will ultimately lead to a stack of residual products of mainly the ballast material with properties similar to the backfill. If there are unfilled parts inside the confinement the degradation of the roof will cause the backfill on top of the roof to fall into these empty parts and create open space at the rock roof instead.

When the BTF room has been water saturated the water transport through the room is governed by the hydraulic gradient in the surrounding rock. The high hydraulic conductivity of the backfill compared to the concrete containment will direct the water flow to go above the containment and assure a very low hydraulic gradient through the containment (hydraulic contrast). The water transport through the containment and past the waste packages depends then very much on the occurrence of cracks and joints in the concrete containment. After degradation of the concrete the hydraulic cage effect will disappear and the water will flow through the confinement.

Dependencies between process and system component variables

Table 6-4 summarises how the process influences and is influenced by all BTF variables and how these effects are handled.

Table 6-4. Direct dependencies between the process “Water transport under saturated conditions” in BTF and the defined variables and a short note on the handling.

Variable	Variable influence on process		Process influence on variable	
	Influence present? Yes/No	Description Handling of influence How/If not – Why	Influence present? Yes/No	Description Handling of influence How/If not – Why
Geometry	Yes.	Geometry included in the model.	No.	–
Temperature	No, but indirectly through water viscosity.	See row water composition.	No.	–
Hydrological variables	Yes, basic variables.	Variables in the model.	Yes.	Variables in the model.
Mechanical stresses	Yes.	Negligible since the water flow rate is low.	Yes.	Negligible since the water flow rate is low.
Material composition	Yes, hydraulic conductivity.	Sensitivity analyses.	No, but indirectly through transport of degraded cement.	See Section 6.4.1. Advection and dispersion.
Water composition	Yes, mainly through the viscosity.	Negligible since the change in viscosity is small.	No, but indirectly through transport of degraded cement.	See Section 6.4.1. Advection and dispersion.
Gas variables	No, since the process assumes water saturation.	–	No.	–

Boundary conditions

Interaction between the backfill and the rock: A key issue for the water flow process is the interaction between rock and backfill, which is assumed to be sand or macadam. Water is conducted to the backfill mainly in the water-bearing fractures, which means that water saturation can be uneven. However, the high hydraulic conductivity of the backfill will make the water flow go rather evenly in the backfill.

Interaction between concrete and the rock: The slot between the walls and the rock are grouted with concrete, which will form the boundary with the rock. The water flow through the walls depends on how the fractures in the rock interact with possible cracks in the concrete. If there is no connection the water flow through walls will probably be very slow before degradation of the concrete. However, after degradation of the concrete, water will flow evenly also through the concrete.

Interaction between the backfill and the concrete structure: The high hydraulic conductivity of the backfill will make the water flow go around the concrete and form a well-defined boundary to the roof of the concrete structure.

Interaction with the plugs: The plugs will seal off the BTF vault from the access tunnels and prevent water leakage from the backfill material.

Model studies/experimental studies

There are numerous examples of water flow in concrete structures in engineering practice. Also, backfill type of materials have been investigated and used for engineering purpose in numerous tests and practices. Hence, no studies with explicit purpose to investigate the water flow in BTF like structures have been performed.

Natural analogues/observations in nature

Not applicable since the system is engineered. The macro-scale hydraulic properties of natural cements are not fully relevant to an engineered system.

Time perspective

The process starts when the BTF has reached full saturation and continues during the rest of the BTF lifetime. The properties of the concrete will however vary during this time due to the degradation.

Handling in the safety assessment SR-PSU

The process water flow under saturated condition will be decisive for the safety assessment. The magnitude of water flow through the confinement is expected to vary with time and increase successively when the concrete containment is degraded.

The following handling in the safety assessment is anticipated:

1. Definition of the initial state with specification of concrete quality, backfill material and containment design.
2. Investigation of the degradation rate of the concrete, which may be a function of several factors.
3. Determination of the hydraulic properties of degraded concrete.
4. Modelling of the water flow through the BTF vaults with different hydraulic boundary conditions.

Timescales: The entire life time of the repository will be included. The concrete degradation process is described by several degradation states.

Boundary conditions: The rock will be included in the model. Different rock structures and boundary conditions will be used.

Handling of variables influencing this process: All the influencing variables in the table, except temperature, will be included in the analyses

Handling of variables influenced by this process: All the influenced variables except temperature will be included in the analyses.

Handling of uncertainties in SR-PSU

Given the adopted handling in the safety assessment SR-PSU as described above, the handling of different types of uncertainties associated with the process will be summarised.

Uncertainties in mechanistic understanding: The general understanding of saturated flow in backfill and concrete are rather good. The uncertainties are mainly related to the rock properties and the existence of cracks in the concrete, the degradation rate of the concrete and the properties of the degraded concrete.

Model simplification uncertainties: The water flow in the concrete will probably be simplified to water flow in a porous media with properties that vary with time according to the expected degradation rate.

Input data and data uncertainties: The properties of the cracks in the concrete, the degradation rate and the properties of the degraded concrete have large uncertainties.

Adequacy of references supporting the handling in SR-PSU

The references are judged to be adequate and sufficient to support the handling in SR-PSU. All supporting references are either peer-reviewed articles or documents which have undergone factual review. Other references have been used for general background information, and not all of these have been peer-reviewed to the same standard.

6.2.3 Gas transport/dissolution

Overview/general description

Key concepts of gas transport and dissolution in concrete barriers are described in Section 5.2.3. The given descriptions are also relevant to the concrete structures, e.g. floor and skirting, and concrete grout backfill of the BTF. The porosity of the concrete grout backfill is approximately three times higher than structural concrete (Höglund 2001), and the larger pores result in a lower capillary pressure to resist the displacement of water. The grout is also structurally weaker than the structural concrete, and so will fracture at lower pressures. Therefore, gas transport pathways will form in the concrete grout rather than in the concrete barriers (Moreno et al. 2001).

Dependencies between process and system component variables

The BMA and BTF will experience similar gas dissolution and transport processes. The main relevant differences are the different geometries and porosities of the cementitious materials used. Therefore, the influence of the specified set of physical variables on gas transport and dissolution, and how these processes influence the variables are judged to be the same as for BMA, as shown in Table 5-5.

Boundary conditions

See Section 5.2.3.

Model studies/experimental studies

See Section 5.2.3.

Natural analogues/observations in nature

Not applicable.

Time perspective

See Section 5.2.3.

Handling in the safety assessment SR-PSU

Gas transport and dissolution are important considerations in the safety assessment for the BTF and are handled using the same approach as for the BMA (see Section 5.2.3).

Handling of uncertainties in SR-PSU

Uncertainties in mechanistic understanding: Uncertainties in the mechanistic understanding of gas transport and dissolution are generic and not specific to the BTF. They are therefore handled in the same way as for the BMA (see Section 5.2.3).

Model simplification uncertainties: Gas transport and dissolution are modelled using the same simplifications as for the BMA, and the impact of these simplifications is assessed in a similar way (see Section 5.2.3).

Input data and data uncertainties: The input data are affected by the uncertainties discussed for the BMA (see Section 5.2.3). Equally, the uncertainties are reduced as much as possible and the impact of the uncertainties assessed using the same approach as for the BMA.

Adequacy of references supporting the handling in SR-PSU

The references are judged to be adequate and sufficient to support the handling in SR-PSU. All supporting references are either peer-reviewed articles or documents which have undergone factual review. Other references have been used for general background information, and not all of these have been peer-reviewed to the same standard.

6.3 Mechanical processes

6.3.1 Mechanical processes

Changes in stress conditions in the concrete barriers may cause cracking.

External and internal load will change the stress in the barriers. Examples of internal load are swelling and gravitation. Change in stress and loss of structural integrity may cause deformation and redistribution.

Overview/general description

A number of mechanical processes may occur in the backfill and the concrete containment. The following is a list of mechanical processes in the **backfill of sand**:

- Stresses caused by the own weight of the backfill.
- Hydraulic stresses.
- Settlement by wetting.
- Deformation caused by stress changes.
- Creep deformations.
- Effects of concrete degradation.
- Effects of displacements and fall out in the roof and walls of the rock vault.
- Effects of freezing.
- Stresses caused by gas formation.

When the backfill is water unsaturated the capillary forces between the grains may affect the stresses from the own weight of the backfill to such an extent that the backfill will be kept at a loose structure if the emplacement is done without compaction. When the backfill gets water saturated the capillary forces will disappear and the backfill may settle into a higher density and leave a slot at the roof.

After full water saturation the effective stress is governing the mechanical behaviour. The effective stress is the difference between the total stress and the water pressure according to Equation (6-1). See e.g. Hansbo (1975).

$$\sigma' = \sigma - Au \quad (6-1)$$

where

σ' = effective stress

σ = total stress

u = porewater pressure

$A = 1.0$ for normal soils

The mechanical properties of the backfill sand depend on mainly the grain size distribution and the density. The density is in turn a function of the grain size distribution, the grain particle form and the compaction effort. See e.g. Andreasson (1973).

The **concrete** may also be affected by a number of mechanical processes:

- Stresses caused by the own weight of the concrete, the backfill and the waste packages.
- Hydraulic stresses.
- Deformation caused by stress changes.
- Creep deformations.
- Effects of concrete degradation caused by chemical processes.
- Indirect effects of displacements and fall out in the roof and walls of the rock vault.
- Stresses caused by corrosion of the reinforcement.
- Cracking.
- Effects of freezing.

Many of these processes are however insignificant for the behaviour.

In the long time perspective the concrete is expected to crack and be degraded by chemical processes. This will ultimately lead to a stack of residual products of mainly the ballast material with properties similar to the backfill.

Dependencies between process and system component variables

Table 6-5 summarises how the mechanical processes influences and are influenced by all BTF variables and how these effects are handled.

Boundary conditions

The BTF has the rock as boundary. The different parts of the BTF have several boundaries.

Backfill

The backfill has the rock as a mechanical fixed outer boundary except for the process of rock fall out and rock displacements. The other boundary of the backfill is the concrete structure, which may interact mechanically with the backfill. The most important interactions are the effects of concrete degradation and the gas generation from inside the concrete structure.

Concrete

The concrete has the backfill, the waste moulds and the rock under and beside the structure as boundaries. There is an interaction with the backfill (see above). There is also an interaction with the waste packages mainly through the gas production but also by the degradation of the concrete. The rock under the structure behaves like a fixed mechanical boundary.

Plugs

The plugs will seal off the BTF vault from the access tunnels and prevent water leakage from the backfill material. However, the mechanical interaction will be considerable. There is a transition material between the backfill in the BTF and the bentonite plugs and this material will be compressed by the swelling bentonite. This will also lead to some compression of the backfill in the BTF. See also Section 10.3.1.

Table 6-5. Direct dependencies between the mechanical processes in BTF and the defined variables and a short note on the handling.

Variable	Variable influence on process		Process influence on variable	
	Influence present? Yes/No	Influence Description	Influence present? Yes/No	Influence Description
Geometry	Yes.	Included in the model.	Yes, since stresses always cause displacements.	Deformations in caverns, backfill and concrete structures are assessed.
Temperature	Yes.	Negligible, since temperature changes and gradients are small.	No.	
Hydrological variables	Yes, e.g. the stresses change when the vault is filled with water.	Included in HM models.	Yes, displacements may cause water pressure changes.	Included in HM-models, but very small.
Mechanical stresses	Yes, since stresses cause displacements and creep.	Included in HM models.	Yes, since displacements cause stresses.	Included in HM models.
Material composition	Yes, determines the properties.	Sensitivity analyses.	No.	
Water composition	Indirectly through chemical effects on the concrete, which will be degraded.	See Section 6.4.5 Chemical processes. The change in barrier function will be analysed.	No.	
Gas variables	Yes, gas pressure may be generated and cause stresses.	Will be modelled.	No.	

Model studies/experimental studies

No studies with explicit purpose to investigate the mechanical processes in BTF like structures have been performed, but the backfill type of materials and concrete structures have been investigated and used for engineering purpose in numerous tests and practices.

Natural analogues/observations in nature

See Section 5.3.1.

Time perspective

See handling in the safety assessment.

Handling in the safety assessment SR-PSU

Some of the mechanical processes may affect safety and will be included in the safety assessment. All subprocesses listed under overview/description will be commented on.

Backfill of sand

- Stresses caused by the own weight of the backfill.
- Settlement by wetting.

These processes will be analysed since the effect of a slot at the roof must be considered and included in the water flow modelling.

- Hydraulic stresses.
- Creep deformations.

These are small and will not be considered. The hydraulic stresses are after saturation are small since there are very small hydraulic gradients. Sand is not sensitive to creep.

- Effects of concrete degradation.

Will be analysed, see also Section 6.4 Chemical processes.

- Effects of displacements and fall out in the roof and walls of the rock vault.

Will be analysed. Rock pieces in the roof may fall down and compact the backfill, which leads to open slots at the remaining roof.

- Effects of freezing.

May be analysed, see also Section 6.1.2 Phase changes/freezing.

- Stresses caused by gas formation.

May be analysed, see also Section 6.2.3 Gas transport/dissolution.

- Deformation caused by stress changes.

Will be analysed in connection with the other mechanical processes.

Concrete

- Stresses caused by the own weight of the concrete, the backfill and the waste packages.

Will be neglected before degradation but after degradation these stresses may cause settlement and additional opening of the slot at the roof. This will be analysed.

- Hydraulic stresses.
- Creep deformations.

These are small and can be neglected. The hydraulic stresses are after saturation are small since there are very small hydraulic gradients. Concrete is not sensitive to creep.

- Effects of concrete degradation caused by chemical processes.

This is an important process that will have impact on the integrity of the BTF. The process is handled in Section 6.4.5. If the concrete degradation is strong the possible change in barrier function will be analysed.

- Indirect effects of displacements and fall out in the roof and walls of the rock vault.

Not very strong effects and may probably be neglected since it will only cause small changes in properties of the sand.

- Stresses caused by corrosion of the reinforcement.
- Cracking.

These will contribute to the degradation. The handling is described in Section 6.4 Chemical processes.

- Effects of freezing.

Will contribute to the degradation, see Section 6.1.2.

- Stresses caused by gas generation.

These will probably be small since the gas can escape through the concrete cracks but this process must be investigated (see also Section 6.2.3).

- Interaction with the waste packages.
- Deformation caused by stress changes.

Can be disregarded before the concrete degradation but may be important during and afterwards.

The concrete will crack and completely change its properties with time. The degradation rate and rest product should be investigated in order to predict the change in properties with time. The concrete may be modelled as completely degraded with properties similar to sand after a certain time.

Timescales: The entire life time will be included. The processes can be divided into two different time periods; before and after degradation of the concrete.

Boundary conditions: The rock will constitute the boundary in the analyses.

Handling of variables influencing this process: All the influencing variables in the table, except temperature, will be included in the analyses

Handling of variables influenced by this process: All the influenced variables will be included in the analyses.

Handling of uncertainties in SR-PSU

Given the adopted handling in the safety assessment SR-PSU as described above, the handling of different types of uncertainties associated with the process will be summarised.

Uncertainties in mechanistic understanding:

Backfill

The mechanical properties are well known and the related mechanical processes well understood.

Concrete

The mechanical properties of the un-degraded concrete are well known and the mechanical processes well understood. The properties during and after degradation are more uncertain. A way to overcome these uncertainties may be to treat the concrete as completely degraded and turned into a sand heap after a certain time.

Model simplification uncertainties: The lack of knowledge of the properties of the degraded concrete may make it necessary to treat the concrete as completely degraded and turned into a sand heap after a certain time.

Input data and data uncertainties: See model simplifications.

Adequacy of references supporting the handling in SR-PSU

The references are judged to be adequate and sufficient to support the handling in SR-PSU. All supporting references are either peer-reviewed articles or documents which have undergone factual review. Other references have been used for general background information, and not all of these have been peer-reviewed to the same standard.

6.4 Chemical processes

6.4.1 Advection and dispersion

Overview/general description

Solutes can be transported to and from the interior of the concrete barriers in the 1BTF and 2BTF repository parts by advection and diffusion (see further Section 6.4.2). See also Section 6.5.2 for the handling of radionuclide transport in the water phase.

In this report, advection refers to the transport of a dissolved substance by the bulk flow of water. The evolution of the groundwater flow conditions in the barriers will therefore have a direct and important impact on the advective transport of dissolved species. For 1BTF and 2BTF, the safety function of limited advective transport applies (see further Section 3.2), and the performance indicator for this safety function is the hydraulic conductivity of the barriers. The hydraulic conductivity strongly relates to the local groundwater flow, which is driven by pressure gradients and is affected by the properties of the media, such as the permeability, porosity and presence of cracks, and the fluid properties, such as the density and viscosity. The processes of water transport in 1BTF and 2BTF under unsaturated and saturated conditions are described separately in Sections 6.2.1 and 6.2.2, respectively.

Although the dimensions and configuration of the engineered barrier system are different in the 1BTF and 2BTF from those in BMA, the mechanistic principles for the processes of advection and dispersion are the same. Throughout this section, repetition is avoided by referencing to the process description for BMA in Section 5.4.1 when appropriate.

A general overview and description of the processes of advection and dispersion is provided in Section 5.4.1 and is not further described here.

Dependencies between process and system component variables

The barriers in 1BTF and 2BTF are similar in many aspects to those in BMA, although the geometry and configuration of the barrier system components differ. The influence of the specified set of physical variables on the processes of advection and dispersion, how these processes influence the variables, and the corresponding handling of each influence are therefore judged to be the same as for BMA. These dependencies and the corresponding handling in the safety assessment are described in detail in Section 5.4.1, and are not further described here.

Boundary conditions

The boundary conditions for the processes of advection and dispersion are the groundwater flow rates, the degree of water saturation and the groundwater chemical composition at the physical boundaries of the barrier and the waste form.

Model studies/experimental studies

See Section 5.4.1.

Natural analogues/observations in nature

See Section 5.4.1.

Time perspective

See Section 5.4.1.

Handling in the safety assessment SR-PSU

The processes of advection and dispersion in the BTF barriers are handled within PSU in the same way as the corresponding processes in the BMA, see Section 5.4.1. This applies also to the handling of uncertainties.

Adequacy of references supporting the handling in SR-PSU

See Section 5.4.1.

References

See Section 5.4.1.

6.4.2 Diffusion

Overview/general description

Section 5.4.2 introduces the key generic concepts of diffusion in porous media. The concrete floor slab and concrete lid of the BTF will be constructed using the same cement as in the BMA. Therefore, the porosity of the concrete (Section 5.4.2), the porewater composition (Section 5.4.7) and the effective diffusivity of species in these structures will follow a similar evolution over time. The bulk characteristics of the wastes in the BTF and BMA are also similar, thus the leachates are expected to be of a similar pH, Eh and ionic strength.

The spaces between the concrete waste tanks and the shotcrete-lined rock walls of BTF will be backfilled with grout, up to and including the concrete lid. The porosity of grout is approximately three times higher than that of the concrete structures (Höglund 2001) thus the effective diffusivity of species will be higher through the grout (see Section 5.4.2). There will also be a sand/gravel back-fill layer on top of the grouted concrete structure, which will offer the lowest barrier resistance to diffusion in the BTF.

Dependencies between process and system component variables

The BMA and BTF are similar in terms of aqueous speciation and reactions, and the major controls over these. Therefore, Table 5-8 and the associated justifications are applicable to the BTF.

Boundary conditions

The boundary conditions are the barriers themselves with exchange of mass from the waste/waste package and the surrounding geosphere considered.

Model studies/experimental studies

See Section 5.4.2.

Natural analogues/observations in nature

See Section 5.4.2.

Time perspective

See Section 5.4.2.

Handling in the safety assessment SR-PSU

Diffusion is a core consideration in the safety assessment for the BTF and is handled using the same approach as for the BMA (see Section 5.4.2).

Handling of uncertainties in SR-PSU

Uncertainties in mechanistic understanding: Uncertainties in the mechanistic understanding of diffusion are generic and not specific to the BTF. They are therefore handled in the same way as for the BMA (see Section 5.4.2).

Model simplification uncertainties: Diffusion is modelled using the same simplifications as for the BMA (see Section 5.4.2).

Input data and data uncertainties: The input data are affected by the limitations discussed for the BMA (see Section 5.4.2).

Adequacy of references supporting the handling in SR-PSU

The references are judged to be adequate and sufficient to support the handling in SR-PSU. All supporting references are either peer-reviewed articles or documents which have undergone factual review. Other references have been used for general background information, and not all of these have been peer-reviewed to the same standard.

6.4.3 Sorption

Overview/general description

The sorption processes in cementitious and gravel barrier components are the same as in the corresponding components of BMA, see Sections 5.4.3 and 5.4.4. This holds for the general descriptions of processes and relevant solids as well as all individual radionuclides discussed there.

Dependencies between processes and barrier variables

Table 6-6 and Table 6-7 summarise how the process sorption influences and is influenced by all BTF variables and how these effects are handled. In addition, the handling of each influence in SR-PSU is indicated in the tables. Because of the significant differences in material properties, a separate process/variable table is given for the cementitious and gravel components of the barrier.

Boundary conditions

Relevant boundary conditions are those that control the transport of solutes to and from the barrier in 1BTF and 2BTF; i.e. the boundary conditions of the processes advection and diffusion.

Model studies/experimental studies

The model and experimental studies for concrete/cement and sand/gravel material discussed in Sections 5.4.3 and 5.4.4 applies here as well.

Natural analogues/observations in nature

See Sections 5.4.3 and 5.4.4.

Time perspective

See Sections 5.4.3 and 5.4.4.

Table 6-6. Direct dependencies between the process ‘sorption’ and cementitious system component variables and a short note on the handling in SR-PSU.

Variable	Variable influence on process		Process influence on variable	
	Influence present? Yes/No	Description Handling of influence How/If not – Why	Influence present? Yes/No	Description Handling of influence How/If not – Why
Geometry	No.	Sorption is a molecular-level chemical process which is not directly influenced by macroscopic geometry.	No.	See material composition.
Temperature	Yes.	Temperature will have an effect on solids composition and on sorption processes.	No.	–
Hydrological variables (pressure and flows)	No.	No direct influence on sorption.	No, but indirectly via material composition and geometry (Incorporation of major ions in HCP may cause mineral expansion and alter flowpaths).	See material composition.
Mechanical stresses	No.	–	No, but indirectly, see hydrological variables.	–
Material composition	Yes.	The composition of the material influences its sorption properties.	Yes.	Incorporation of major ions in HCP may cause mineral alteration.
Water composition	Yes.	Water composition can directly affect sorption and influence mineralogy.	Yes.	Incorporation of major ions in HCP influences dissolved concentration.
Gas variables	No direct influence.	CO ₂ can influence sorption indirectly through effects on water composition and mineralogy. H ₂ and CH ₄ can influence sorption indirectly through creating reducing conditions (water composition).	Included in selected. K _d where relevant. Separate degradation phases are considered.	Yes. Considered in the description of cement degradation (process Concrete degradation 6.4.5).
			Included in K _d where relevant.	Handled through solubility products.
			No direct influence.	Not considered.
			Indirectly through influencing dissolved concentrations (especially Ca). No significant effects expected.	

Handling in the safety assessment SR-PSU

Before saturation, the process is neglected. After saturation: radionuclide sorption is included in the modelling of radionuclide transport. Sorption is quantified using K_d values that are specific for each element (and oxidation state, where relevant). Process uncertainties can generally be expressed through the use of bounding K_d values for both barrier materials.

For the cement-based barrier materials, the exchange behaviour of major elements is included in the chemical degradation process (see Section 6.4.5). For the sand/gravel component, the exchange behaviour of major elements is not addressed explicitly (the possible alteration of the sand/gravel component is not modelled).

Table 6-7. Direct dependencies between the process ‘sorption’ and variables of the sand/gravel barrier component.

Variable	Variable influence on process		Process influence on variable	
	Influence present? Yes/No Description	Handling of influence How/If not – Why	Influence present? Yes/No Description	Handling of influence How/If not – Why
Geometry	No. Sorption is a molecular-level chemical process which is not directly influenced by macroscopic geometry.	–	No. The geometry of the crystalline minerals in gravel and sand does not depend on sorbed ions.	–
Temperature	Yes. Temperature will have an effect on sorption processes.	No. Influence of temperature on sorption must be expected, but trend and magnitude are not clear. Where sorption data for relevant temperatures are available, they are taken into account in the selection of RN K_d values.	No.	–
Hydrological variables (pressure and flows)	No. No direct influence on sorption.	–	No, see geometry.	–
Mechanical stresses	No.	–	No, see geometry.	–
Material composition	Yes. The composition of the material influences its sorption properties.	Included in selected K_d where relevant.	No. The bulk composition of the minerals in gravel and sand does not depend on sorbed ions.	–
Water composition	Yes. Water composition can affect sorption.	Included in K_d where relevant.	Yes. Sorption of major ions could influence dissolved concentration.	Handled through solubility products.
Gas variables	No direct influence. CO_2 can influence sorption indirectly through aqueous speciation. H_2 and CH_4 can influence sorption indirectly through creating reducing conditions (water composition).	Included in K_d where relevant.	No direct influence. Indirectly through influencing dissolved concentrations. No significant effects expected.	–

Handling of uncertainties in SR-PSU

Uncertainties are the same as in case of BMA, see Section 5.4.3.

6.4.4 Colloid stability, transport and filtering

Overview/general description

A general overview and description of the processes of colloid transport and filtering is provided in the corresponding section for the BMA barriers, i.e. Section 5.4.5. Although the dimensions and configuration of the engineered barrier system are different in the 1BTF and 2BTF from those in BMA, the mechanistic principles for the processes of colloid transport and filtering are the same. The colloidal input from the waste in the BTF is expected to be at a similar concentration to that in the BMA; the waste has a similar bulk material composition of concrete and cement (~70%) (Almkvist and Gordon 2007), generating similar high pH and ionic strength conditions for colloid stability. Throughout this section, repetition is avoided by referencing to the process description for BMA in Section 5.4.5 when appropriate.

Dependencies between process and system component variables

The barriers in BTF are similar in many aspects to those in BMA, although the geometry and configuration of the barrier system components differ. The influence of the specified set of physical variables on colloid transport and filtration and how these processes influence the variables are therefore judged to be the same as for BMA. These dependencies are described in detail in Section 5.4.5, and are not further described here.

Boundary conditions

The boundary conditions for the processes of colloid transport and filtration are the water flow rates, degree of water saturation, and the water composition (e.g. pH and ionic strength) at the physical boundaries of the barrier to the waste form and to the surrounding geosphere.

Model studies/experimental studies

For a description of model and experimental studies of colloid transport and filtration that may be of relevance for the studied system, see Section 5.4.5.

Natural analogues/observations in nature

For a description of natural analogues and observations of colloid transport and filtration that may be of relevance for the studied system, see Section 5.4.5.

Time perspective

For a description of time related aspects that may be of relevance for the studied system, see Section 5.4.5.

Handling in the safety assessment SR-PSU

Colloid transport and filtration in the BTF barriers are handled within PSU in the same way as the corresponding processes in the BMA, see Section 5.4.5.

Adequacy of references supporting the handling in SR-PSU

See Section 5.4.5.

6.4.5 Concrete degradation

Section 5.4.6 introduces the key concepts behind dissolution/precipitation/ recrystallisation processes. The concrete floor slab and concrete lid of the BTF will be constructed using the same cement as in the BMA, thus the concrete will follow a similar chemical, mineralogical and mechanical evolution to that in the BMA (see Section 5.4.6). The BTF will be backfilled with concrete grout filling the spaces between the concrete waste tanks and the shotcrete-lined rock walls, up to and including the concrete lid. This will contribute to highly alkaline, high ionic strength conditions. The porosity of the concrete grout backfill is approximately three times higher than structural concrete (Höglund 2001) and will provide a permeable path for groundwater. There will also be a sand/gravel backfill layer on top of the concrete structure, which may influence the porewater chemistry and provide some buffering of hydroxide (Section 5.4.6).

The waste in the BTF is of lower radioactivity than that in the BMA but has a similar bulk material composition of concrete and cement (~70%) and iron and steel (12–15%) (Almkvist and Gordon 2007). Therefore, the pH, ionic strength and reducing conditions of the waste leachate reaching the barrier are expected to be similar to those found in the BMA waste leachate. There is also a similar ion exchange resin content. The main differences between the BTF and BMA wastes of importance for the dissolution/precipitation/recrystallisation processes are the presence of ashes at a few percent of the waste by mass and no evaporator concentrate in the BTF wastes. Therefore salts are expected to be present at lower concentrations in the BTF waste leachate than in the BMA.

Dependencies between process and system component variables

The BMA and BTF are very similar in terms of dissolution/precipitation/recrystallisation processes, and the major controls over these. The main relevant differences are the different geometries and porosities of the cementitious materials used, and these are defined in the models. Therefore, Table 5-12 and the associated justifications are applicable to the BTF.

Boundary conditions

The boundaries of this analysis are the barriers themselves with exchange of mass from the waste/waste package, plugs in access tunnels and the surrounding geosphere considered.

Model studies/experimental studies

See Section 5.4.6.

Natural analogues/observations in nature

See Section 5.4.6.

Time perspective

See Section 5.4.6.

Handling in the safety assessment SR-PSU

Concrete degradation involving dissolution/precipitation/recrystallisation processes are central considerations in the evaluation of the physical and chemical integrity of the barriers and are included in geochemical assessment models used for the BTF.

Handling of uncertainties in SR-PSU

Uncertainties in mechanistic understanding: Uncertainties in mechanistic understanding of dissolution/precipitation/recrystallisation processes are generic and not specific to the BTF. They are therefore handled in the same way as for the BMA (Section 5.4.6.)

Model simplification uncertainties: Dissolution/precipitation/recrystallisation processes are modelled using the same simplifications as for the BMA (Section 5.4.6).

Input data and data uncertainties: The input data are affected by the limitations discussed for the BMA (Section 5.4.6).

Adequacy of references supporting the handling in SR-PSU

The references are judged to be adequate and sufficient to support the handling in SR-PSU. All supporting references are either peer-reviewed articles or documents which have undergone factual review. Other references have been used for general background information, and not all of these have been peer-reviewed to the same standard.

6.4.6 Aqueous speciation and reactions

Overview/general description

Section 5.4.7 introduces the key concepts behind aqueous speciation and reactions for the BMA, and summarises temporal changes to the groundwater in the vicinity of SFR. The BTF will be constructed using the same cement as used for the BMA, thus the concrete porewater will follow a similar evolution to that in the BMA. The BTF will be backfilled with concrete grout and this will contribute to highly alkaline, high ionic strength conditions. There will also be a sand/gravel backfill layer on top of the concrete structure, which may influence the groundwater chemistry and buffer the alkaline plume to some extent (SKB 2008b).

Dependencies between process and system component variables

The BMA and BTF are very similar in terms of aqueous speciation and reactions, and the major controls over these. Therefore, Table 5-14 and the associated justifications are applicable to the BTF.

Boundary conditions

The boundaries of this analysis are the barriers themselves with exchange of mass from the waste/waste package, plugs in the access tunnels and the surrounding geosphere considered.

Model studies/experimental studies

See Section 5.4.7.

Natural analogues/observations in nature

See Section 5.4.7.

Time perspective

See Section 5.4.7.

Handling in the safety assessment SR-PSU

Aqueous speciation and reactions are central considerations in the geochemical model used for the BTF. See Section 5.4.7.

Handling of uncertainties in SR-PSU

Uncertainties in mechanistic understanding: Uncertainties in mechanistic understanding of aqueous speciation and reactions are generic and not specific to the BTF. They are therefore handled in the same way as for the BMA (Section 5.4.7).

Model simplification uncertainties: Aqueous speciation and reactions are modelled using the same simplifications as for the BMA (Section 5.4.7).

Input data and data uncertainties: The input data are affected by the limitations discussed for the BMA (Section 5.4.7).

Adequacy of references supporting the handling in SR-PSU

The references are judged to be adequate and sufficient to support the handling in SR-PSU. All supporting references are either peer-reviewed articles or documents which have undergone factual review. Other references have been used for general background information, and not all of these have been peer-reviewed to the same standard.

6.4.7 Microbial processes

Overview/general description

See Section 5.4.8. BMA for overview of microbial processes.

The microbial processes on grout and concrete barriers are expected to be negligible as most activity will be in the waste itself (see the **Waste process report**). Due to the fact that the amount of bioavailable carbon is lower in BTF than in BMA, microbial processes at the barrier surfaces in the repository are expected to be less than in BMA. The waste in BTF consists mostly of dewatered ion exchange resins that are not easily degraded by microbes while the waste in BMA consists of a mix of a variety of different waste materials that are easier for microbes to use.

Dependencies between process and system component variables

The dependences between microbial processes and BTF grout and concrete variables are the same as in BMA (see BMA Section 5.4.8).

Boundary conditions

The same boundary conditions apply as for BMA.

Model studies/experimental studies

Model studies on the influence of microbial processes on BTF barriers remains to be performed.

Natural analogues/observations in nature

See corresponding section in chapter about BMA regarding natural analogues.

Time perspective

Although microbial processes are likely to be on-going throughout the lifetime of the repository, the dominating process at different time interval may differ. At hyperalkaline conditions the diversity as well as the microbial activity is expected to be extremely low. For details on time perspective see corresponding section in chapter about BMA.

Handling in the safety assessment SR-PSU

Process neglected as pH is expected to be hyperalkaline in the cement and concrete barriers during the first 100,000 years (Cronstrand 2007).

Handling of uncertainties in SR-PSU

Uncertainties in mechanistic understanding: The basic scientific mechanisms governing the described microbial processes are well understood but their relevance for BTF barriers and extent in BTF barriers is not known. Studies have not been performed under relevant SFR conditions. However, such studies are possible to perform in SFR that has been in operation for a significant time.

Model simplification uncertainties: Models have not been developed. Model studies have not been performed and data is not available.

Input data and data uncertainties: Model studies have not been performed and data is not available.

Adequacy of references supporting the handling in SR-PSU

The references are judged to be adequate and sufficient to support the handling in SR-PSU. All supporting references are either peer-reviewed articles or documents which have undergone factual review.

6.4.8 Metal corrosion

Metal is present in the reinforced concrete floor and lid barriers of the BTF vaults, and in the rock bolts in the shotcrete-lined rock walls. The metal used for both reinforcement and rock bolts is carbon steel. The concrete grout surrounding the waste packages and the backfill in the BTF do not contain any metal.

The major source of metals (iron/steel, aluminium and zinc) in the BTF as a whole is the waste packages (Moreno et al. 2001). Corrosion of metallic waste and metals in waste packaging is described in the **Waste process report**.

In BTF, metal corrosion of reinforcement bars is of importance for predictions of degradation of concrete structures as well as for estimates of oxygen depletion and for rates of subsequent gas formation.

Overview/general description

A general description of steel corrosion related to reinforced concrete in the BMA vault is given in Section 5.4.9.

Dependencies between process and system component variables

Metal corrosion occurs in a similar way in the BTF and BMA barriers, although the geometry and configuration of the barrier system components differ. The influence of the specified set of physical variables on metal corrosion and how this process influences the variables are therefore judged to be the same as for BMA. These dependencies are described in detail in Section 5.4.9, and are not described further here.

Boundary conditions

See Section 5.4.9.

Model studies/experimental studies

See Section 5.4.9.

Natural analogues/observations in nature

See Section 5.4.9.

Time perspective

See Section 5.4.9.

Handling in the safety assessment SR-PSU

The corrosion of metal reinforcement bars in concrete structures, rock reinforcements and rock bolts in BTF is considered in the safety assessment in terms of:

- Evolution of redox conditions.
- Contribution to gas formation in the vault.

Adequacy of references supporting the handling in SR-PSU

The references are judged to be adequate and sufficient to support the handling in SR-PSU. All supporting references are either peer-reviewed articles or documents which have undergone factual review. Other references have been used for general background information, and not all of these have been peer-reviewed to the same standard.

6.4.9 Gas formation

Gas formation is important within the BTF barriers (i.e. the concrete plank and floor, and grout) as it will increase the pressure of the system once the saturation limit of the water phase is reached, i.e. when no further gas can be dissolved. Elevated pressure could lead to transport of gas (Section 5.2.3). The waste packages are the main source for gas formation in BTF (Moreno et al. 2001). The different chemical processes causing gas formation in the waste packages are described in the **Waste process report**.

Hydrogen evolving corrosion of the reinforcement bars in the concrete barriers will contribute to the total amount of gas formed in the BTF (Moreno et al. 2001). More minor potential sources of gas formation in the barriers are through microbial degradation of organic material that migrates in from the waste or geosphere, and radiolysis of water.

Overview/general description

General descriptions of hydrogen evolving metal corrosion and gas formation are given in Sections 5.4.9 and 5.4.10, respectively, while the handling of metal corrosion in the BTF barriers is described in Section 6.4.8. Section 5.4.8 describes microbial processes, including gas formation.

Dependencies between process and system component variables

Gas formation occurs through similar mechanisms in the BTF and BMA barriers, although the geometry and configuration of the barrier system components differ. The influence of the specified set of physical variables on gas formation and how this process influences the variables are therefore judged to be the same as for BMA. These dependencies are described in detail in Section 5.4.10, and are not described further here.

Boundary conditions

See Section 5.4.10.

Model studies/experimental studies

See Section 5.4.10.

Natural analogues/observations in nature

See Section 5.4.10.

Time perspective

See Section 5.4.10.

Handling in the safety assessment SR-PSU

Hydrogen evolving corrosion of reinforcement bars in concrete structures, rock reinforcement and rock bolts in the BTF will be considered in the safety assessment in terms of gas formation in the vault. Hydrogen evolving corrosion is assumed to start instantaneously.

Adequacy of references supporting the handling in SR-PSU

The references are judged to be adequate and sufficient to support the handling in SR-PSU. All supporting references are either peer-reviewed articles or documents which have undergone factual review. Other references have been used for general background information, and not all of these have been peer-reviewed to the same standard. This applies to the following:

6.5 Radionuclide transport

6.5.1 Speciation of radionuclides

Radionuclide speciation is a fundamental process whose general features are independent of the specific environment. A general process description is given in the corresponding chapter for BMA, see Section 5.5.1. Moreover, the chemical environments in the cementitious and crushed rock components can be expected to be the same as in the corresponding components of BMA, and therefore the same dependencies between processes and barrier variables are anticipated.

Table 6-8. Direct dependencies between the process ‘speciation of radionuclides’ and system component variables and a short note on the handling in SR-PSU.

Variable	Variable influence on process		Process influence on variable	
	Influence present? Yes/No Description	Handling of influence How/If not – Why	Influence present? Yes/No Description	Handling of influence How/If not – Why
Geometry	No. Speciation is a molecular-level chemical process which is not influenced by geometry.	–	No.	–
Temperature	Yes. Temperature will effect speciation.	Effect of temperature on equilibria is considered in speciation models using thermodynamic data or approximations.	No.	–
Hydrological variables (pressure and flows)	No (no direct influence on speciation).	–	No.	–
Mechanical stresses	No.	–	No.	–
Material composition	Indirectly through porewater composition.	See water composition.	No. Radionuclides are only trace constituents.	–
Water composition	Yes. Water composition directly affects speciation.	Water composition considered in speciation modelling.	Yes. Speciation effects the chemical form of the dissolved radionuclides and in that sense water composition. Radionuclide concentrations are at trace levels and do not influence bulk water composition.	Included in speciation modelling.
Gas variables	Indirectly by influencing water composition.	See water composition.	No. Radionuclides are only trace constituents and do not effect the bulk gas composition, their speciation does not influence bulk gas composition.	

Handling in the safety assessment SR-PSU

Radionuclide speciation is only relevant after saturation and in case of a release of radionuclides. The speciation of radionuclides is calculated based on thermodynamic data (i.e. assuming equilibrium) and may be used to define solubility limits where relevant.

Radionuclide speciation is also used to assess their sorption behaviour. In case of cement-based materials there is a high degree of similarity between expected conditions and those in relevant laboratory experiments. Therefore, a qualitative representation of speciation (in particular of hydrolysis at high pH) is normally sufficient. For sorption on crushed rock, an approach similar to bentonite is followed, where relevant.

6.5.2 Transport of radionuclides in the water phase

The radionuclide transport modelling for the BTF tunnels is very similar to the modelling of BMA (See corresponding process description for BMA (Section 5.5.2)).

However, the BTF tunnels do not have a natural sectioning like the storage rooms in BMA and hence the discretisation of the BTF models is made in a simpler way. See the **Radionuclide transport report** for details.

Dependencies between process and system component variables

Table 6-9 shows how transport of radionuclides in the water phase in the BTF system is influenced by the specified set of physical variables and how the process influences the variables.

Boundary conditions

The inner boundary for the radionuclide transport processes is the concentration of nuclides in the interior of the BTF tunnels. The outer boundary is the concentration in the rock outside the repository.

Model studies/experimental studies

Radionuclide transport in 1BTF and 2BTF has been studied in several earlier safety assessments (Wiborgh et al. 1987, Lindgren et al. 2001, Thomson et al. 2008b). In these studies an early degradation of the concrete (in comparison to BMA and silo) has been assumed, leading to a significant release of radionuclides. This has led to an assumption of relatively high radiologic risk due to releases of e.g. C-14 in organic form from 1BTF and 2BTF.

Natural analogues/observations in nature

Not applicable.

Time perspective

Transport of radionuclides in the water phase will be relevant at all time scales in SFR.

Handling in the safety assessment SR-PSU

See the corresponding section for BMA.

Handling of uncertainties in SR-PSU

See the corresponding section for BMA.

Adequacy of references supporting the handling in SR-PSU

See the corresponding section for BMA.

6.5.3 Transport of radionuclides in the gas phase

See corresponding process description for BMA (Section 5.5.3).

Table 6-9. Direct dependencies between “Transport of radionuclides in the water phase” and system component variables and a short note on the handling in SR-PSU.

Variable	Variable influence on process		Process influence on variable	
	Influence present? Yes/No	Handling of influence Description How/If not – Why	Influence present? Yes/No	Handling of influence Description How/If not – Why
Geometry	Yes. Gives the volumes and areas available for transport.	Yes. Geometry variables are included in RN-transport model.	No.	–
Temperature	Yes.	No. Effects are negligible.	No.	–
Hydrological variables	Yes. Water fluxes are highly significant for advective transport of RN.	Yes. Detailed flow parameters are included in the RN model.	No.	–
Mechanical stresses	No.	–	No.	–
Material composition	Yes. Sorption properties are highly dependent on material composition.	Yes. Material specific K_d values are included in the RN model.	No.	–
Water composition	Yes. Sorption properties are dependent on water composition.	Yes. Considered in the selection of K_d data.	Yes.	The porewater concentration of radionuclides in all parts of the system is calculated.
Gas variables	No.	–	No.	–

7 Silo

7.1 Thermal processes

7.1.1 Heat transport

The heat transport process is described in the corresponding section for the BMA repository (Section 5.1.1). This description also applies here.

Dependencies between process and system component variables

Table 7-1 shows how the process influences, and is influenced by, all system variables.

Table 7-1. Direct dependencies between the process “Heat transport” and the defined system variables and a short note on the handling in SR-PSU.

Variable	Variable influence on process		Process influence on variable	
	Influence present? Yes/No Description	Handling of influence How/If not – Why	Influence present? Yes/No Description	Handling of influence How/If not – Why
Geometry	Yes, the constitution of the system determine how heat flows.	The process is not explicitly handled. See Section 5.1.1.	No.	
Temperature	Yes. Temperature differences is an requirement for the process.	The process is not explicitly handled. See Section 5.1.1.	Yes. Heat transport tends to even out temperature differences.	The process is not explicitly handled. See Section 5.1.1.
Hydrological variables	Yes. Water flow may transport heat. Heat capacities may change with saturation state and aggregation state.	The process is not explicitly handled. See Section 5.1.1.	Yes, through e.g. convection. The influence is however negligible because temperature differences are small.	The process is not explicitly handled. See Section 5.1.1.
Mechanical stresses	Yes, in principle as e.g. heat capacities may depend on stress state. The effect is however negligible.	The process is not explicitly handled. See Section 5.1.1.	Yes. Due to thermal expansion/contraction.	The process is not explicitly handled. See Section 5.1.1.
Material composition	Yes. Different materials have different thermal conductivities, specific heats etc.	The process is not explicitly handled. See Section 5.1.1.	No.	
Water composition	Yes in principle as e.g. heat capacities may depend on composition. The effect is however negligible.	The process is not explicitly handled. See Section 5.1.1.	No.	
Gas variables	Yes. Gas flow may transport heat.	The process is not explicitly handled. See Section 5.1.1.	Yes, but relevant only during the operational phase when the repository is not water saturated.	The process is not explicitly handled. See Section 5.1.1.

Boundary conditions

See Section 5.1.1.

Model studies/experimental studies

See Section 5.1.1.

Natural analogues/observations in nature

See Section 5.1.1.

Time perspective

See Section 5.1.1.

Handling in the safety assessment SR-PSU

See Section 5.1.1.

Handling of uncertainties in SR-PSU

See Section 5.1.1

7.1.2 Phase changes/freezing

Overview/general description

The process description made in Section 5.1.2 also applies for the silo. The presence of bentonite in this component, however, requires some special consideration.

The swelling pressure of bentonite can in principle be viewed as an osmotic pressure. As such, its magnitude is dependent both on the internal properties of the bentonite, as well as on the properties of the external solution with which the bentonite is in contact. Specifically, in the temperature range between the freezing point of the external solution and the freezing point of the bentonite, the swelling pressure drops approximately linearly with temperature (Birgersson et al. 2010).

$$P_s(\Delta T) = P_s^0 + \frac{\Delta s}{v_{\text{clay}}} \Delta T \approx P_s^0 + 1.2 \text{ MPa}/^\circ\text{C} \cdot \Delta T \quad (7-1)$$

where P_s^0 is swelling pressure under unfrozen conditions, Δs is the difference in partial molar entropy between water in the clay and bulk water, v_{clay} is the partial molar volume of water in the bentonite, and ΔT is the temperature interval below the freezing point of the external solution.

The freezing point of the bentonite coincides with the temperature where swelling pressure vanishes. Therefore the bentonite freezing point is directly related to the swelling pressure under unfrozen conditions. Below the freezing point, ice forms gradually with decreasing temperature. Hence, below the freezing point there is equilibrium between ice and bentonite with a certain unfrozen water content. This behaviour is completely analogous to freezing of a salt solution, where there is equilibrium between the ice and the remaining, more concentrated, solution (see Section 5.1.2).

Consequences of freezing for SFR

The same arguments as put forward in Section 5.1.2 also apply for the silo. In the present case, however, also the presence of bentonite and sand/bentonite mixtures must be considered.

Dependencies between process and system component variables

Table 7-2 shows how the process influences, and is influenced by, all Silo barrier variables.

Table 7-2. Direct dependencies between the process “Phase changes/freezing” and the defined system variables and a short note on the handling in SR-PSU.

Variable	Variable influence on process		Process influence on variable	
	Influence present? Yes/No Description	Handling of influence How/If not – Why	Influence present? Yes/No Description	Handling of influence How/If not – Why
Geometry	Yes. Freezing point is influenced by confinement geometry if it is small (sub microns). Frost susceptibility depends on pore geometry.	Freezing points (or temperature intervals) are estimated for each component material.	Yes. Pore geometries may be different after freezing. Fractures may have been created or widened. Cycles of freezing/thawing may cause particle sorting.	Altered hydraulic conductivity after permafrost period. Ice lens formation in bentonite will be quantified.
Temperature	Yes. The freezing point is a certain temperature.	Freezing points (or temperature intervals) are estimated.	Yes. Freezing releases energy. Thawing consumes energy.	Neglected.
Hydrological variables	Yes. Water pressure have a minor influence on freezing point.	Insignificant, unless very high pressures.	Yes. Freezing may cause pressure increase and affect water flow. Freezing may also reduce conductivity (a completely frozen system does not flow).	The barrier function of concrete is considered lost after a freezing/thawing cycle. Possible changes in hydraulic conductivity of the bentonite is estimated.
Mechanical stresses	Yes. Pressure influences freezing point.	Insignificant, unless very high pressures involved.	Yes. Freezing and frost heave may induce stresses and strains.	Altered hydraulic conductivity after permafrost period. Effect on host rock is estimated. Ice lens formation in bentonite will be quantified.
Material composition	Yes. Freezing point is influenced by surface properties.	Freezing points (or temperature intervals) are estimated.	No.	
Water composition	Yes. Freezing point is influenced by type and concentration of solutes.	Estimated from water chemistry.	Yes. Freezing may change composition of remaining unfrozen water.	Neglected, because possible freezing is slow in comparison to diffusive and advective mass transfer.
Gas variables	No. Indirectly through dissolved gases.	Insignificant unless gas pressures are high. Handled via water composition.	No.	

Boundary conditions

Temperature in the repository set by climate evolution. (Pore) geometries of the components.

Ice lens formation can only occur as long as there is access to liquid water from below.

Model studies/experimental studies

See Section 5.1.2.

The swelling pressure response of water-saturated samples of MX-80 bentonite at various water contents has been measured down to temperatures of around -10°C (Birgersson et al. 2008, 2010). The pressure drop as described by Equation III was shown to agree quantitatively with measurement results. Also the existence of a water content dependent temperature where swelling pressure is completely lost was demonstrated. The processes were shown to be completely reversible during several freezing/thawing cycles.

Natural analogues/observations in nature

See Section 5.1.2.

Time perspective

See Section 5.1.2.

Handling in the safety assessment SR-PSU

Comments on specific materials

Concrete: See section Section 5.1.2.

Bentonite: As the swelling pressure of the silo bentonite is low, well below 1 MPa (Pusch 2003), the corresponding freezing point is close to 0°C (not taking into account possible excess salt effects) and freezing will occur in the barrier during permafrost periods. However, freezing of bentonite has been shown to be reversible (Birgersson et al. 2010), i.e. it is expected that the bentonite regains its properties upon thawing.

The ice forms gradually with decreasing temperature in the bentonite, i.e. at a specific temperature below the freezing point there is a corresponding ratio of frozen and unfrozen water. A substantial amount of water in the bentonite is still unfrozen also at temperatures in the range –5 to –10°C. Consequently, as temperature lowers to –5 – –10°C, ice will develop in the bentonite while the flow paths of the surroundings are frozen. Hence damaging stress states might be developed, leading to cracking of the adjacent concrete (see Section 7.3.1), or fracture widening of the host rock.

Furthermore, as long as flow paths are open below the silo, ice lens formation which leads to damaging stress states may occur in the bentonite. Emborg et al. (2007) estimate a maximum frost heave on the orders of 0.01–1 m, based on the assumption that the freezing front takes 2,000 years to pass the repository. A further study on the ice lens formation in the silo components will be conducted.

Sand/Bentonite mixtures: A sand/bentonite mixture is placed below (and above) the silo. This mixture contains approximately 90% sand and will therefore have a negligible frost susceptibility. However, a pressure/stress increase is expected at temperatures below 0°C as bentonite containing liquid water will be contained in a frozen sand matrix.

The hydraulic conductivity of the sand/bentonite mixture could in principle be altered due to repeated cycles of freezing and thawing. Emborg et al. (2007), however, argues that the fact that the clay part is swelling, will make this effect negligible.

Sand: See Section 5.1.2.

Handling of uncertainties in SR-PSU

Uncertainties in mechanistic understanding

The physical mechanisms described here are well described and well studied phenomena.

Model simplification uncertainties

See Section 5.1.2. The exact variation with temperature of thermodynamic properties of bentonite (e.g. entropies) is not very well investigated.

Input data and data uncertainties

The concluded reversibility of the freezing/thawing cycle on bentonite is based on laboratory tests on cm sized samples of rather high density and pressure and in a negligible temperature gradient. Unknown effects of upscaling might be possible.

Adequacy of references supporting the handling in SR-PSU

The references are judged to be adequate and sufficient to support the handling in SR-PSU. All supporting references are either peer-reviewed articles or documents which have undergone factual review. Other references have been used for general background information, and not all of these have been peer-reviewed to the same standard.

7.2 Hydraulic processes

7.2.1 Water uptake and transport during unsaturated conditions

Overview/general description

The design of the silo with several materials in different geometrical configurations makes the water saturation phase rather complicated. The saturation process is delayed by the barriers. At first the water has to penetrate the shotcrete cement on the rock walls, which probably mainly takes place in cracks in the shotcrete. Then the bentonite barriers have to be saturated. Then the concrete structures in the silo must be penetrated by water, which does not take place until the bentonite barrier is saturated (at least locally). The cement and concrete filled rooms will then be filled with water before the water can reach the waste packages. Also here the concrete will crack and water will probably enter the waste packages through these cracks. The water filling of the waste packages may thus take place before the cement and concrete matrix is water saturated.

The water saturation will thus take place through a combination of matrix flux through the bentonite barriers, matrix flux through the cement and concrete barriers and fracture flow in cracks in the cement and concrete barriers.

The effect of gas production is treated in Section 7.2.3.

Matrix flow

Water transport in porous materials under unsaturated conditions is a complex process that is dependent on, inter alia, material composition, temperature, degree of water saturation and water content. The most important driving force for water saturation under SFR conditions is a gradient in water pressure or relative humidity in the pores of the material that follows after water inflow from the surrounding rock. The supply of water from the rock by water transport in fractures and in the rock matrix is also a decisive factor for the temporal evolution of the process.

The general description of water flow in the matrix of concrete and backfill given in Sections 5.2.1 and 5.2.2 is also valid for these materials and the bentonite in the Silo and will not be repeated.

The properties of bentonite/sand mixtures have been investigated in the laboratory and in the field. See e.g. Johannesson et al. (1999) and Goudarzi et al. (2005).

Piping and subsequent water flow in the pipes may strongly affect the water saturation phase.

Fracture flow in cracks

The nature of the cracks will decide how the flow takes place. In micro cracks the flow may be unsaturated and be similar to matrix flux. However, since the micro cracks are not well interconnected this flow will not dominate. In macro cracks the water will successively fill up the crack in a rate that is mostly determined by the access to water at the opening of the crack. The total rate of water inflow into the cement and concrete in the macro cracks is thus mainly determined by:

- Crack frequency.
- Water accessibility at the crack opening.

Flow in the sand filling

The high hydraulic conductivity in the sand means that the water flow is not delayed by the sand but controlled by the water inflow rate. The sand filling will be filled successively in a front like manner and not from the bottom if the sand is not self-draining (water will not flow to the bottom of the sand by the own weight of the water). See also Section 5.2.1.

Entrapped air

An important factor that may strongly delay the time to full water saturation of the entire silo is the entrapment of air. The water will fill up in a front like manner and air may be entrapped both inside the waste, inside the surrounding bentonite fillings and (if the sand is not self-draining) in the sand filling. The average water pressure of about 500 kPa will decrease the air volume to about 20% of its original volume. This air must probably escape through diffusion, which means that there may be a “steady state” situation with entrapped air with the same air pressure as the water pressure for a rather long time.

Dependencies between process and system component variables

Table 7-3 summarises how the process influences and is influenced by all Silo variables and how these effects are handled. In addition, the handling of each influence in SR-PSU is indicated in the table.

Boundary conditions

Interaction with the rock: A key issue for the saturation process is the interaction between rock and the clay based fillings. Water is conducted to the clay fillings mainly in the water-bearing fractures, which means that water saturation can be both uneven and rather slow. However, the high hydraulic conductivity of the sand will spread the water in the sand on top of the silo at the same rate as the water inflow.

Local inflow from rock fractures may lead to piping and erosion which may strongly affect the wetting process.

Interaction between the sand and the top clay filling: The sand will rather soon be water filled and supply a saturated hydraulic boundary to the clay filling. So the hydraulic boundary condition will be hydrostatic water pressure.

Interaction between the clay fillings and the concrete: The clay fillings will delay the wetting of the concrete. It will not start until the clay fillings are close to water saturation. It may though also be uneven.

Interaction between the top filling and the plugs: The plugs will seal off the Silo from the access tunnels and prevent water leakage from the backfill material in the tunnels.

Model studies/experimental studies

No studies with explicit purpose to investigate the wetting of silo like structures have been performed, but the sand type of materials have been investigated and used for engineering purpose in numerous tests and practices. There are also numerous examples of wetting of concrete structures in engineering practice. The properties of many types of clay fillings have been investigated in relation to early studies of the silo design and especially for use in KBS-3V and depend strongly on the composition. Modelling studies of the water saturation of bentonite/sand mixtures have been performed for the Backfill and Plug Test (Börgesson and Hernelind 1998) and for SR-Can (Börgesson et al. 2006).

Natural analogues/observations in nature

Not applicable since the system is engineered in a way not found in nature.

Table 7-3. Direct dependencies between the process “Water uptake and transport under unsaturated conditions” in the Silo and the defined variables and a short note on the handling.

Variable	Variable influence on process		Process influence on variable	
	Influence present? Yes/No Description	Handling of influence How/If not – Why	Influence present? Yes/No Description	Handling of influence How/If not – Why
Geometry	Yes.	Geometry included in the model.	No.	
Temperature	No, but indirect through water viscosity.	See water composition.	Yes, wetting and drying effects.	Negligible.
Hydrological variables	Yes, basic variables.	Variables in the model.	Yes.	Variable in the model.
Mechanical stresses	Yes.	Variable in the model.	Yes.	Variable in the model.
Material composition	Yes, hydraulic conductivity and retention curve.	Sensitivity analyses.	No, but indirectly if erosion takes place.	See Section 7.2.4 Piping/erosion.
Water composition	Yes, mainly through the viscosity.	Negligible.	No.	
Gas variables	Yes, via gas pressure and degree of saturation.	Variable in the model.	Yes.	Variable in the model.

Time perspective

The time until full saturation depends very much on the rock conditions and the existence of cracks in the concrete. The process is expected to be rather slow due to the clay fillings and combinations of tight rock, fracture free concrete and entrapped air may probably prolong it to several hundred years.

Handling in the safety assessment SR-PSU

The water saturation of the silo may be delayed and take several hundreds of years. This may not have a significant impact of the radionuclide release, but it is anyway important to have a good description and understanding of the evolution.

The saturation evolution will consequently be modelled. The concrete in existing vaults is highly cracked (e.g. in BMA). In SKB (2008b) it is assumed that the hydraulic conductivity of the concrete is rather high (10^{-9} m/s), which would correspond to an average of the cracked concrete. On this reason the concrete will be considered cracked in the base case but also the case of uncracked concrete will be analysed. In order to make the modelling easier a porous media approach will be used.

Timescales: The time scale will be illustrated by the modelling results. The uncertainties of many parameters and the complicated geometry make the modelling difficult but the time to full saturation will be framed.

Boundary conditions: The rock will be included in the model and the mapped fractures included, but the complicated geometry may require simplifications such as having the rock as a boundary condition. If there is a highly permeable disturbed zone in the rock surface this will simplify the model. Different boundary conditions will be used to reflect the influence.

Handling of variables influencing this process: All the influencing variables in the table, except temperature, will be included in the model.

Handling of variables influenced by this process: All the influenced variables will be included in the model. The degree of saturation as a function of time and space will be modelled.

Handling of uncertainties in SR-PSU

The uncertainties are mainly related to the rock properties and the existence of cracks in the concrete.

Uncertainties in mechanistic understanding: The general understanding of unsaturated flow in clay fillings and concrete are rather good. The main uncertainties are the extent of cracking and the properties of the cracks in the concrete. Additional tests of the specific clay fillings used in the silo should be made in order to check those materials.

Model simplification uncertainties: Since the number, properties and time evolution of cracks in the concrete are not well known the two extremes of either completely lost barrier function of the concrete with high hydraulic conductivity or unspoiled and uncracked concrete with low hydraulic conductivity will be investigated.

Input data and data uncertainties: The properties of the concrete and the specific clay fillings used in the silo are the most uncertain. The properties of the clay fillings should be investigated in order to confirm input data to the modelling.

Adequacy of references supporting the handling in SR-PSU

The references are judged to be adequate and sufficient to support the handling in SR-PSU. All supporting references are either peer-reviewed articles or documents which have undergone factual review. Other references have been used for general background information, and not all of these have been peer-reviewed to the same standard.

7.2.2 Water transport under saturated conditions

Overview/general description

After full water saturation of all parts of the silo and after re-establishment of the natural hydrostatic conditions, very little water will flow through the silo due to the low gradient and the low hydraulic conductivity of the bentonite and concrete barriers. Just as for unsaturated conditions the detailed water flow processes in the silo is complicated due to the complicated geometry and differences in hydraulic properties of the barriers. There will mainly be matrix flow in the bentonite barriers while the flow in the cement and concrete barriers is expected to be concentrated to the macro cracks.

After long time the cement is expected to be degraded and the hydraulic barrier of the cement and concrete eventually lost. The water transport will thus very much depend on the time factor of the degradation process.

Water flow in saturated porous material is a special case of unsaturated flow. The number of processes to consider is fewer (vapour flux, phase transitions and air phases do not exist). Those processes that are involved are essentially the same as for unsaturated conditions, but can vary widely in importance when compared with unsaturated conditions.

The most important mechanism under saturated conditions is transport of water in the liquid phase, which is driven by a water pressure gradient. This transport process can be described by Darcy's Law. Any deviations from Darcy's Law, which can occur at low gradients, are favourable in that they lead to a reduced flow-through rate (e.g. Dixon et al. 1999, Hansbo 1960). The hydraulic conductivity, K is a function of the material composition, the void ratio, e , the ion concentration in the porewater, i_c , and the temperature, T .

The hydraulic conductivity of the mixture of 10% bentonite and 90% sand in the bottom of the silo may vary between 10^{-8} and 10^{-10} m/s depending on the dry density, the grain size distribution of the sand and the chemical composition of the ground water (Johannesson et al. 1999). See also Pusch (2003).

The hydraulic conductivity of the bentonite barrier along the silo walls is expected to be about 10^{-9} m/s depending on the density and the chemical composition of the ground water.

Piping and erosion may lead to increased hydraulic conductivity if the pipes are not healed (see Section 7.2.4).

Ion exchange will affect the hydraulic conductivity.

After degradation of the concrete by dissolution of the cement there may be voids in contact with the bentonite barrier. If this causes expansion of the bentonite, the density will decrease and the hydraulic conductivity will increase.

The large amount of cement in contact with the bentonite based barriers will affect the properties of the bentonite based barriers. The amount of effected bentonite based barrier, the magnitude of the effect and the evolution of this effect over time are not well known today and depend to a large part of the concrete composition. See Section 7.4.10 Montmorillonite transformation.

The hydraulic conductivity of the sand and cement-stabilised sand is rather high and expected to range between 10^{-6} and 10^{-2} m/s depending on the grain size distribution and the cement content.

The hydraulic conductivity of concrete depends very much on the quality of the concrete. If the concrete is free from fractures the hydraulic conductivity may be very low. However, the existence of joints and probable cracks will dominate the hydraulic behaviour. See also Section 5.2.2.

The hydraulic conductivity of degraded cement and concrete is expected to be in the same order of magnitude as the sand.

Freezing may accelerate the degradation, see Section 7.1.2.

Dependencies between process and system component variables

Table 7-4 summarises how the process influences and is influenced by all Silo processes variables and how these effects are handled.

Boundary conditions

Interaction with the rock: A key issue for the water flow process is the interaction between rock and the clay based fillings. Water is conducted to the clay fillings mainly in the water-bearing fractures, which means that water flow in the clay filling in the floor and walls may be very low and uneven. However, the high hydraulic conductivity of sand will spread the water in the sand on top of the silo and cross-circuit the water pressure to be without gradient in the sand.

Local inflow from rock fractures may lead to piping and erosion which may result in remaining open channels that may strongly affect the hydraulic properties.

Interaction between the sand and the top clay filling: The sand will affect the top clay filling with a constant water head.

Interaction between the clay fillings and the concrete: The clay fillings will interact with the concrete in a similar way as with the rock. The low hydraulic conductivity in the clay will minimise the flow through the fractures in the concrete and efficiently delay the water flow through the waste packages. After degradation of the concrete the flow rate will increase.

Interaction with the plugs: The plugs will seal off the Silo from the access tunnels and minimise water flow from the backfill material in the tunnels.

Model studies/experimental studies

No studies with explicit purpose to investigate the water flow in Silo like structures have been performed, but the backfill type of materials have been investigated and used for engineering purpose in numerous tests and practices. See e.g. Johannesson et al. (1999). There are also numerous examples of water flow in concrete structures in engineering practice.

Table 7-4. Direct dependencies between the process “Water transport under saturated conditions” in the Silo and the defined variables and a short note on the handling.

Variable	Variable influence on process		Process influence on variable	
	Influence present? Yes/No	Handling of influence Description How/If not – Why	Influence present? Yes/No	Handling of influence Description How/If not – Why
Geometry	Yes.	Geometry included in the model.	No.	–
Temperature	No, but indirectly through water viscosity.	See row water composition.	No.	–
Hydrological variables	Yes, basic variables.	Variables in the model.	Yes.	Variable in the model.
Mechanical stresses	Yes.	Negligible since the water flow rate is low.	Yes.	Negligible.
Material composition	Yes, through hydraulic conductivity.	Sensitivity analyses.	No, but indirectly through erosion and transport of degraded cement if it occurs.	See Section 7.4.1 Advection and dispersion.
Water composition	Yes, mainly through the viscosity.	Negligible since the change in viscosity is small.	No, but indirectly from degraded cement since e.g. Ca may be dissolved in the flowing water.	See Section 7.4.1 Advection and dispersion.
Gas variables	No, since the process assumes water saturation.	–	No.	–

Natural analogues/observations in nature

Not applicable since the system is engineered and too complex to be compared with an analogue.

Time perspective

The process starts when the Silo has reached full saturation and continues during the rest of the lifetime of the Silo. The properties of the concrete will however vary during this time due to the degradation.

Handling in the safety assessment SR-PSU

The process water flow under saturated condition will be decisive for the safety assessment. The rate of water flow through the waste containers is expected to vary with time and increase successively when the concrete and cement barriers are degraded and is also affected by the geochemical influence of the concrete on the bentonite based barriers.

The following handling in the safety assessment is anticipated:

1. Definition of the initial state with specification of concrete quality and bentonite barriers etc.
2. Estimation of the effect of piping and erosion (see Section 7.2.4).
3. Investigation of the degradation rate of the concrete, which may be a function of several factors (see Section 5.4.6).
4. Investigation of the effect of cement dissolution and possible volume decrease (see Section 5.4.6).
5. Investigation of the geochemical influence of the concrete on the bentonite based barriers, which may be a function of several factors (see e.g. Sections 7.4.6 and 7.4.10).
6. Modelling of the water flow through the Silo with different hydraulic boundary conditions.
7. Sensitivity analyses.

Timescales: The time after saturation throughout the assessment period.

Boundary conditions: The expected hydraulic gradient in the surrounding rock will be used as boundary conditions. Different boundary conditions will be used to reflect the influence.

Handling of variables influencing this process: All the influencing variables in the table, except temperature, will be included in the model. The expected change in properties of the cement and concrete will be included. The expected change in properties of the bentonite based barriers caused by the geochemical influence of the concrete will be considered. The properties of completely degraded and completely unaltered cement will be used to frame the flow rate.

Handling of variables influenced by this process: All the influencing variables in the table, except temperature, will be included in the model. The water flow rate will affect the degradation rate of the concrete as well as the geochemical influence on the bentonite based barriers and needs to be taken into account.

Handling of uncertainties in SR-PSU

Given the adopted handling in the safety assessment SR-PSU as described above, the handling of different types of uncertainties associated with the process will be summarised.

Uncertainties in mechanistic understanding: The general understanding of saturated flow in clay filling and concrete are rather good. The uncertainties are mainly related to the rock properties and the existence of cracks in the concrete, the degradation rate of the concrete and the properties of the degraded concrete. The effect of piping and erosion is also uncertain (see Section 7.2.4).

Model simplification uncertainties: The water flow in the concrete will probably be simplified to water flow in a porous media with properties that vary with time according to the expected degradation rate.

Input data and data uncertainties: The properties of the cracks in the concrete, the degradation rate and the properties of the degraded concrete have large uncertainties.

Adequacy of references supporting the handling in SR-PSU

The references are judged to be adequate and sufficient to support the handling in SR-PSU. All supporting references are either peer-reviewed articles or documents which have undergone factual review. Other references have been used for general background information, and not all of these have been peer-reviewed to the same standard.

7.2.3 Gas transport/dissolution

Overview/general description

The Silo has the most advanced design among the different components of the SFR repository; all waste is conditioned, all waste packages are embedded in porous concrete, there is an internal compartment structure of concrete, the outer walls are made of thick concrete, and above all the concrete silo is surrounded by bentonite (SKB 2008b).

After the Silo is sealed, groundwater will seep in from the surrounding rock, gradually filling the empty voids and pores of the barriers and the waste. The time until full saturation depends very much on the rock conditions and the existence of cracks in the concrete. The re-saturation process is expected to be particularly slow in the Silo due to the bentonite. If the rock was tight, the concrete free of fractures, and air was entrapped in the barriers, resaturation would be expected to take several hundred years, see Section 7.2.1.

Gas may become trapped in the Silo during this re-saturation phase and gas will also form within the waste (**Waste process report**) and, to a lesser extent, in the barriers (see Section 7.4.16). In many aspects, the process descriptions for gas transport and dissolution are generic and relevant descriptions are given in Section 5.2.3. In this section, the aspects that are specific to the Silo are highlighted.

Gas accumulation and transport in the Silo

The gas transport and the quantity of water expelled from the Silo repository are determined by the design of the Silo and the properties of the barrier materials. In the Silo, the waste is surrounded by a porous concrete with low resistance to gas transport and the Silo top is planned to be equipped with gas evacuation pipes in the concrete lid. The gas is presumably transported through the porous concrete to the top of the Silo, since the cylindrical concrete wall, while intact and without fractures, and the surrounding bentonite may constitute higher resistances for the gas to penetrate. Only a small gas pressure is required to open up gas passages in the porous concrete, and the quantity of water that is expelled has been measured experimentally to be 0.1–2% of the pore volume (Björkenstam 1997). It has been assumed in the gas transport calculations that 2% of the pore volume in the concrete can be displaced. In order for the gas to find its way out through the gas evacuation pipes and the sand/bentonite barrier in the top, a gas pressure must be built up in the Silo concrete equivalent to the opening pressure of the sand/bentonite barrier. Experiments show that a pressure of approximately 15 kPa is required to achieve gas transport through the sand/bentonite and that the expelled water is only a few tenths of a percent of the total pore volume (Pusch and Hökmark 1987).

The build-up of gas pressure in the system and subsequent release of gas could result in partial displacement of porewater from Silo. Displacement of porewater increases the likelihood of radionuclide release. A certain gas pressure needs to be established in order for water to be expelled, and this depends on the hydraulic conductivities of the barrier materials and the surrounding rock. In a gravel fill, only small pressures are required to open up transport pathways and to drive the gas through the porosity in the fill. Gas that has flowed through gravel fill and arrived at the void underneath the roof in the Silo repository and the rock vaults can then be further transported in fractures in the surrounding rock. Gas release is dependent on the fracture system of surrounding rock, but estimates show that only a few rock fractures are required to release the gas generated in a repository (Braester and Thunvik 1988). This result is also supported by more recent studies of gas transport in fractured rock. The gas breakthrough occurs quickly and gas is transported through the more permeable fractures, while the fluid in the fractures with lower permeability is almost stagnant (Berger and Braester 2000). The presence of gas flow paths allows the pressure in the system to equilibrate, and prevents further expulsion of water. A possible consequence of gas release is that radioactive gases may also be transported to the biosphere, see Section 7.5.3.

Construction concrete has a very fine pore structure, which means that very high pressures can build up before water is expelled and gas can flow. For high quality construction concrete this pressure may be as high as 1.5 MPa (Möller et al. 1981). The concrete structures in SFR are not designed to tolerate such high pressures. Small fractures in the concrete are therefore beneficial, as they offer lower resistance to the gas and prevent pressure-induced damaged. For example for fractures with apertures of 10 µm, gas flow may be established with an overpressure of only 15 kPa (Moreno et al. 2001).

Dependencies between process and system component variables

Table 7-5 shows how the Gas transport/dissolution processes in Silo barriers influences, and is influenced by, all variables of the bentonite barrier, the concrete barriers, the vault and backfill. In addition, the handling of each influence in SR-PSU is indicated in the table and more thoroughly discussed in the text below.

Table 7-5. Dependencies between the processes “Gas transport/dissolution” in the Silo barriers and different system component variables and a short note on the handling in SR-PSU.

Variable	Variable influence on process		Process influence on variable	
	Influence present? Yes/No Description	Handling of influence How/If not – Why	Influence present? Yes/No Description	Handling of influence How/If not – Why
Geometry	Yes, geometry of bentonite and concrete influence the flow resistance and the capillary pressure that need to be exceeded to release gas.	Included in the gas transport modelling.	No, but there is an indirect effect via gas pressure and gas pressurisation that may cause fracture formation (see Section 7.3.1).	
Temperature	Yes, temperature influences the volume, density and viscosity of gas and water.	Temperature is considered in the selection of data for gas transport modelling.	Yes, but effects are judged negligible, see text.	Neglected due to insignificant impact.
Hydrological variables	Yes, the water flow determines the dissipation of dissolved gas. Capillary characteristics of concrete, bentonite and backfill determine the gas pressure build-up and amount of displaced water.	Included in the gas transport modelling.	Yes, the accumulation of gas in porous concrete will redirect water flow and could result in displacement of contaminated water.	Included in the gas transport modelling.
Mechanical stresses	No, but mechanical stresses may have an indirect influence via porosity, occurrence of fractures and gas transport properties in concrete and cause compaction of bentonite.	Considered in the selection of data for certain scenarios for gas transport modelling.	No, although gas pressurisation resulting from limited gas transport may influence mechanical stress (Section 7.3.1).	
Material composition	Yes, the material composition of all barriers determine the gas transport properties and capillary retention of pore water. Indirectly, chemical properties influence the dissolution of gas via changes in water composition.	Considered in the selection of data for gas transport modelling.	No, although there is an indirect influence via water composition, since dissolved carbon dioxide may cause calcite precipitation that may block pores and fractures.	Not relevant.
Water composition	Yes, water composition influences the dissolution of gas. Density and viscosity of water affects the displacement of water by gas.	Considered in the selection of data for gas transport modelling.	Yes, dissolution of gases will affect the water composition. For example, carbon dioxide will influence pH. Hydrogen and methane will influence the redox conditions. Radioactive gas may dissolve in water.	Included in gas transport modelling.
Gas variables	Yes, fundamental parameters for the gas transport.	Considered in the selection of data for gas transport modelling.	Yes, a fundamental impact on the gas variables.	Considered in the selection of data for gas transport modelling.

Influence by geometry

Yes, a direct influence has been identified.

The geometries of the bentonite barrier and the concrete barriers affect the process directly since the flow resistances of barriers are proportional to their thickness. Pressurisation due to the accumulation of trapped gas will depend on the rate of water displacement, which in turn is determined by the flow resistance of the bentonite and the concrete. The cross-sectional area for flow is inversely proportional to the pressure field necessary to displace the water.

Also the pore geometry, the presence and size of fractures in the concrete barriers, the presence of any gaps between different construction parts, and the gas evacuation pipes in the Silo lid will have a direct impact on gas flow as they control the capillary pressure of the concrete. The capillary pressure determines the retention of pore water in the bentonite, the backfill, the porous concrete and the concrete barriers, which directly influences the amount of water that will be displaced at any given gas pressure, and the critical gas pressure required to initiate gas flow.

The geometry of the Silo will have a direct impact on the flow pattern of gas in the Silo barriers and will define the interface between the Silo and the surrounding rock through which the gas needs to escape.

Influence on geometry

No direct influence identified.

However, the pressure required to initiate gas flow through the water saturated concrete in the Silo, if intact, may exceed pressures at which the concrete barriers fracture. More detailed descriptions of the mechanisms leading to fracture formation due to mechanical stresses are given in Section 7.3.1. Due to this risk the gas evacuation pipes in the Silo lid provide paths for the gas to escape at low pressurisation.

Influence by temperature

Yes, a direct influence has been identified.

Temperature directly influences the volume of gas via the general gas law. The temperature also affects the density and viscosity of water and gas and thereby the flow resistance of water and gas. The temperature may also influence the solubility of gas in the water.

Influence on temperature

Yes, a direct influence has been identified.

Gas transport can involve heat transfer. However, SFR will be at the ambient temperature, thus transport of heat by escaping gases is thought to be negligible and will have no impact on the temperature of SFR. Heat exchange due to compression of gas in the repository and subsequent expansion during escape through the concrete barriers is also judged to have a negligible impact.

Influence by hydrological variables

Yes, a direct influence has been identified.

The degree of saturation has a direct influence on the transport of gas in the bentonite barrier, the concrete barriers, the porous concrete, as well as in the backfill. For unsaturated conditions the gas may, to some extent, flow through the bentonite, the concrete barriers, the porous concrete and backfill without the restriction of overcoming the capillary pressure. Under saturated conditions, the pores and fractures are blocked by water and the capillary pressure must be exceeded in order to enable transport of gas. The degree of saturation also determines the maximum transport capacity of gas in a porous or fractured material. At any given gas pressure, the corresponding degree of saturation can be determined and used in estimates of the gas permeability given by different constitutive relationships referred to as relative permeability functions.

The amount of water, in particular the amount of water that can be displaced by gas at a given gas pressure, has a direct impact on the consequences of gas transport in the Silo. If the amount of water that can be displaced is high, the risk of contaminant release from the Silo into the groundwater is high. The amount of water that can be displaced can be characterised by a capillary retention relationship.

During permafrost and/or glaciation, the pore water may freeze and block the pores, hence prevent the transport of gas through the bentonite and the concrete barriers and the backfill. However, under these conditions it is also likely that the gas formation processes would halt. (see Section 5.4.10).

The magnitude and distribution of water flow through and around the Silo will have an indirect influence on the amount of gas that can dissolve and be transported away by the flowing groundwater, via water composition.

Influence on hydrological variables

Yes, a direct influence has been identified.

The generation of a gas phase and the paths the gas will find to escape the Silo will have a direct influence on the magnitude, direction and distribution of water flow in the bentonite barrier, the concrete barriers, the porous concrete and the backfill. At locations where gas penetrates the pores/fractures the flow of water will cease or be restricted, hence water transport will be affected.

The displacement of porewater in the concrete barriers/backfill as a consequence of gas accumulation and gas transport may introduce locally unsaturated zones, which will also directly influence the amount of water in the Silo. During periods of rapid gas accumulation/displacement, the water pressure in the Silo barriers may increase, particularly where there is high capillary pressure in the barrier.

Gas transport and dissolution of gas is not expected to influence the aggregation state of water and/or ice.

Influence by mechanical stresses

No direct influence has been identified.

However, mechanical stresses in the barrier materials could result in compression which may influence the porosity and the pore geometry and thereby the gas transport properties. Mechanical stresses in the bentonite barrier may lead to compaction which affects the permeability and capillary pressure.

Influence on mechanical stresses

No direct influence has been identified.

However, gas pressurisation in the Silo resulting from limited gas transport may influence the mechanical stresses in the barrier materials. With the optional gas evacuation pipes in the Silo lid, the likelihood of significant pressure build-up inside the Silo is low, but it may still be appropriate to consider this in scenario analysis. More detailed descriptions of the impact of mechanical stresses are given in Section 7.3.1.

Influence by material composition

Yes, a direct influence has been identified.

The amount and composition of the bentonite, the construction concrete, the porous concrete, the filling material in gas evacuation pipes, and the backfill material have a direct influence on the gas transport properties. As an example, the surface wetting properties affects the capillary pressure the gas need to supersede in order to open up passages in porous materials. Indirectly, the water to cement ratio in the concrete will determine the total porosity and the size distribution of the concrete pores via geometry. The water content of the bentonite will affect the gas transport properties. Also the grain size distribution of the material selected for the backfill may have a direct impact on the capillary retention characteristics. This in turn will determine the likelihood of pore water displacement as a result of accumulation of gas in the Silo.

The chemical composition of the barrier material has an indirect effect via changes in water composition on the absorption of carbon dioxide that may form in the Silo through the microbial degradation of organic compounds in the waste and waste packaging. This would reduce the amount of carbon dioxide gas pressurising the Silo. Indirectly, via changes of water composition, the chemical interaction between carbon dioxide and calcium leached from the concrete may also result in precipitation of calcite that may affect the porosity and pore geometry of the porous concrete and the characteristics of the filling material in the gas evacuation pipes.

Influence on material composition

No direct influence has been identified.

However, the exposure of cementitious materials to carbon dioxide may via the system variable “water composition” result in the precipitation of calcite. This may result in blocking of pores, fractures, gas evacuation pipes and other voids via changes in the system variable “geometry”, which could affect the transport of other gases, such as hydrogen.

Influence by water composition

Yes, a direct influence has been identified.

The chemical composition of the water has a direct impact on the absorption of carbon dioxide that may form in the Silo due to microbial degradation of organic compounds in the waste and waste packaging. This would reduce the amount of gas in the Silo.

The amount of gas dissolved in the water affects the rate of dissipation of gas from the Silo through advective groundwater flow and diffusion.

The density, surface tension and viscosity of the water have a direct influence on the flow properties of water and hence influence the displacement of pore water in the barriers following gas accumulation.

Influence on water composition

Yes, a direct influence has been identified.

The dissolution of gas will directly influence the water composition. For example, in the case of carbon dioxide this would directly influence the pH of the water. The generation of hydrogen and methane in the repository will influence the redox conditions. Dissolution of radioactive gases would affect the radionuclide content of the water.

Influence by gas variables

Yes, a direct influence has been identified.

This process is fundamentally determined by the gas variables.

Influence on gas variables

Yes, a direct influence has been identified.

This process has a fundamental and essentially defining influence on the gas variables.

Boundary conditions

The relevant boundary conditions in order to treat the process quantitatively are those of the transport processes that control the formation of gas in the waste and barrier materials, see Section 5.4.10 but also the solutes transport between the cement matrix, the waste, the concrete packaging and the groundwater as adjacent system components, i.e. the boundary conditions of the processes diffusion and advection, see Sections 7.4.2 and 7.4.1 respectively.

Model studies/experimental studies

A review of relevant model studies and experimental studies carried out on gas transport is presented in Section 5.2.3.

Of particular relevance for gas transport in the Silo is SKB's research on gas transport which has been focused on Lasgit (Cuss et al. 2010) in the Äspö HRL. Lasgit (Large-Scale Gas Injection Test) is a full-scale experiment with KBS-3V geometry for studying the effect of resaturation and gas transport in the bentonite buffer. Experiments investigating gas flow through clay are also being carried out at the Mont Terri Rock Laboratory (www.mont-terri.ch).

Natural analogues/observations in nature

Not applicable.

Time perspective

The relevant time scales for dissolution and transport of gas in the Silo are determined by:

- The time to resaturate the interior of the Silo by inflowing groundwater, considering also the escape of entrapped air (may take upto hundred years, see Section 7.2.1).
- the onset of gas formation (mainly gas generation by hydrogen evolving corrosion of steel initiated within a few years following depletion of oxygen initially present in the repository), and
- the termination of gas formation (a gradual decrease in gas formation rate over time is expected).

Handling in the safety assessment SR-PSU

The gas transport and the quantity of water expelled from the Silo are determined by the design of the barriers and the properties of the barrier materials. The presence of gas in the Silo will influence the flow of water, and since water is the primary media for the release of radionuclides this is considered in the safety assessment. Further, the generation of significant volume of gas means that pressurisation of the barrier system may occur, potentially leading to stresses and ultimately leading to fracturing of the concrete silo wall. During accumulation of gas and pressure build-up in the vault, pore water will be displaced. This pore water may be contaminated by radionuclides and may lead to an increased release to the groundwater in the rock. Radionuclide release through the displacement of contaminated pore water by gas is quantified in model calculations considering the effects of gas accumulation and the conditions for gas release. Since the prediction of gas generation over time is difficult to assess in detail, the gas accumulation and release calculations are studied by different scenarios.

Handling of uncertainties in SR-PSU

A summary of the uncertainties related to gas formation and migration in performance assessment exercises is given in Norris (2008) and a presentation on how the gas-related processes is handled in different performance assessments can be found in Norris (2009).

Uncertainties in mechanistic understanding: The basic understanding of gas dissolution and transport processes are fairly mature, hence the uncertainties related to the mechanistic understanding are judged to be small.

Model simplification uncertainties: The major uncertainties in the model simplifications are related to the representation of the complex geometry of the different structures in the Silo, the pore geometry of the barriers, the presence and model representation of fractures in the concrete barriers, the representation of bentonite and sand/bentonite barriers and the possible impact of gas evacuation pipes in the Silo lid on gas dissipation into the surrounding rock. The impact of model uncertainties is explored by studying different scenarios.

Input data and data uncertainties: The major uncertainties introduced by the selection of input data and the related data uncertainties are the amount and characteristics of fractures in the concrete barriers, the capillary pressure characteristics of different materials (construction concrete, porous concrete, bentonite buffer, sand/bentonite, sand filling in gas evacuation pipes etc) in the Silo, the

gas transport properties of the different barrier materials at different degrees of water saturation as well as the evolution of these properties over time. The data uncertainties are reduced as much as possible by characterisation of appropriate materials. Remaining uncertainties are handled by parameter variations and probabilistic modelling of the gas release for different scenarios.

Adequacy of references supporting the handling in SR-PSU.

The references are judged to be adequate and sufficient to support the handling in SR-PSU. All supporting references are either peer-reviewed articles or documents which have undergone factual review. Other references have been used for general background information, and not all of these have been peer-reviewed to the same standard.

7.2.4 Piping/erosion

Overview/general description

Water inflow into the bentonite based barriers of the silo will take place mainly through fractures in the rock and in the shotcrete on the rock walls and will contribute to wetting of the bentonite and later also the inner of the silo. However, if the inflow is localised to fractures that carry more water than the bentonite can absorb, there will be a water pressure in the fracture acting on the bentonite. Since the bentonite in the wall fill has a rather low density and swelling pressure, it may be too soft to stop the water inflow. The results may be piping in the bentonite, formation of a channel and a continuing water flow and erosion of soft bentonite gel.

Piping will take place and the pipes remain open if the following three conditions are fulfilled:

1. The water pressure $p_{w,f}$ in the fracture, when water flow is prevented, must be higher than the sum of the counteracting confining pressure from the clay and the shear resistance of the clay.
2. The hydraulic conductivity of the clay must be so low that water flow into the clay is sufficiently retarded to keep the water pressure at $p_{w,f}$.
3. There is a downstream location available for the flowing water and the removal of eroded materials in order for the pipe to stay open.

Erosion will take place if the drag force on a clay particle from water movement is higher than the sum of the frictional and attractive forces between the particle and the clay structure.

Piping can either take place before the bentonite is water saturated if the water inflow is large enough or after water saturation if the water pressure is higher than the swelling pressure and the water inflow is large enough to keep the water pressure.

Erosion can occur both as a consequence of water flow in channels caused by piping and, over the long-term, at the interface between the clay and the fractures in the rock. Since the water flow rate in the latter case is very low, erosion will only be important for colloids leaving the clay gel that has penetrated into the fractures, see Section 7.4.5.

The consequence of piping will be a channel and outflow of water to dry or unfilled parts of the silo. Since the clay swells the channel will reduce in size with time but, on the other hand, erosion will counteract and abrade bentonite particles and thus increase the size of the channel. There is thus a competition between swelling clay and eroding clay. If the inflow is low and the increase in water pressure slow, the pipe may seal before water pressure equilibrium has been reached.

After complete water saturation and homogenisation of the bentonite filling and re-establishment of the hydrostatic water pressure, the water pressure will be separated from the swelling pressure according to the effective stress theory. The pipes or openings caused by the erosion may then be sealed and a swelling pressure established if the density and resulting swelling pressure are high enough to overcome internal friction. Later on, there is very little risk of piping since piping requires a strong and fast increase in water pressure gradient locally in the rock at the contact with the bentonite.

Investigations on piping and erosion were performed and reported in 2007 and 2008 (see below). However, no tests have been made on the bentonite used in the silo at such low densities and with the actual groundwater composition.

The risk of piping and erosion in the bentonite/sand mixture is smaller than in the wall filling due to the high density and low water pressure, but it cannot be excluded. The other barrier materials cannot be subjected to piping and erosion.

Dependencies between process and system component variables

Table 7-6 summarises how the piping process influences and are influenced by all Silo variables. In addition, the handling of each influence in SR-PSU is indicated in the table and more thoroughly discussed in the text below. Since piping and erosion can only take place in the bentonite filling at the walls, the table only refers to this part of the Silo.

The effect of piping and erosion on the hydraulic properties is uncertain. The low density of the bentonite filling may lead to that the pipes and openings caused by erosion will not be sealed which then means that a large part of the sealing properties of the bentonite may be lost. This needs to be investigated.

Boundary conditions

The bentonite filling has the rock and the concrete walls as boundaries. Piping may start at the rock fractures if water inflow cannot be stopped.

Model studies/experimental studies

Piping and erosion has been investigated in several projects.

The processes are studied in the following projects:

- KBS-3H⁵ project.
- Baclo project.
- Buffer installation project.

Piping and erosion are presently thoroughly investigated in the project Eva.

Table 7-6. Direct dependencies between Piping/erosion in the bentonite filling in the Silo and the defined variables and a short note on the handling.

Variable	Variable influence on process		Process influence on variable	
	Influence present? Yes/No Description	Handling of influence How/If not – Why	Influence present? Yes/No Description	Handling of influence How/If not – Why
Geometry	Yes, the path length has an influence.	The geometry is included in the model.	Yes, through lost bentonite.	Amount of lost bentonite is calculated in the analyses.
Temperature	No.	–	No.	–
Hydrological variables	Yes, basic variables.	The hydraulic gradient, the water flow rate and the duration are included.	Indirectly through changes in material composition, density and stresses.	See below.
Mechanical stresses	Yes, determines if piping occurs.	Included.	No, indirectly through changes in material composition, density and stresses.	Yes, may change the density and the stresses and will be included in the analyses.
Material composition	Yes, affects important variables.	Included in the analyses.	Yes, through amount of lost material and may change the composition.	Yes, estimations based on laboratory tests will be made.
Water composition	Yes, the salinity of the ground water affects the erosion rate.	Included in the analyses.	Yes, there will be particles in the eroding water, which will change the viscosity.	No, small effect.
Gas variables	Yes, the degree of saturation has an influence.	Will to some extent be included in the analyses.	No.	

⁵ In the KBS-3H concept, canisters are deposited horizontally in long tunnels, rather than vertically in individual deposition holes.

KBS-3H

KBS-3H is particularly vulnerable to erosion of buffer material since a channel can pass close to a large number of canisters. Tests have been done in three different scales. The results show that the bentonite is very sensitive to piping and erosion and that it may take a considerable time until it heals if the inflow in one spot from a fracture is strong and the build-up of water pressure in the fracture is fast. See Börgesson et al. (2005) and Sandén et al. (2010).

The tests show that the bentonite cannot prevent piping and subsequent erosion unless the pressure or flow rate is very small. The tests also show that the process that stops piping is clogging with valve affects rather than derived from swelling pressure.

Baclo

Tests have been done within the Baclo project in order to investigate the erosion properties of different bentonite materials that may be used both as backfilling blocks and as pellets for filling the slot between the buffer or backfill blocks and the rock (Sandén and Börgesson 2008).

The results show that the erosion rate depends mainly on the composition of the material, the salt content in the eroding water and the total volume of eroded water, but not so much on the flow rate and the length of the flow path. A reduction in eroding rate with time (or water volume) was also observed. A preliminary model (Equation (7-2)) that takes into account the decrease in erosion rate with increasing total volume of eroding water has also been derived (Sandén et al. 2008).

$$m_s = \beta \times (m_w)^\alpha \quad (7-2)$$

where

m_s = accumulated mass of eroded bentonite (g)

m_w = accumulated mass of eroding water (g)

β = 0.02–2

α = 0.65

The model may be used for estimating the total amount of eroded buffer material in various situations. The model needs to be checked with additional tests on the actual bentonite, especially long time tests.

Buffer installation project

The behaviour of the buffer material during the installation phase was investigated in this project. Examples of tests performed included scale tests simulating water inflow into a deposition hole just after filling the slot between the buffer blocks and the rock with pellets.

The mechanical effect on the blocks before and after backfilling above the deposition hole and the hydraulic processes occurring when water seeps in from a rock fracture at different inflow rates have been studied. Results to date show that piping and subsequent erosion occurs as expected and that the material eroding out from the hole into the backfill follows Equation (7-2) with low values of the parameter β (Sandén and Börgesson 2010).

The model is illustrated in Figure 7-1 together with a large number of measurements on different materials under different conditions.

The phenomenon has been observed in two field tests in Äspö HRL (LOT (Karnland et al. 2000) and in the full scale test Lasgit (Cuss et al. 2010). One of the deposition holes in the Prototype Repository has a rather large water inflow and may be used as a check of one scenario for piping erosion. However, this section of the test is not planned to be excavated for many years.

Natural analogues/observations in nature

Piping and erosion may occur in natural deposits but has so far not been studied.

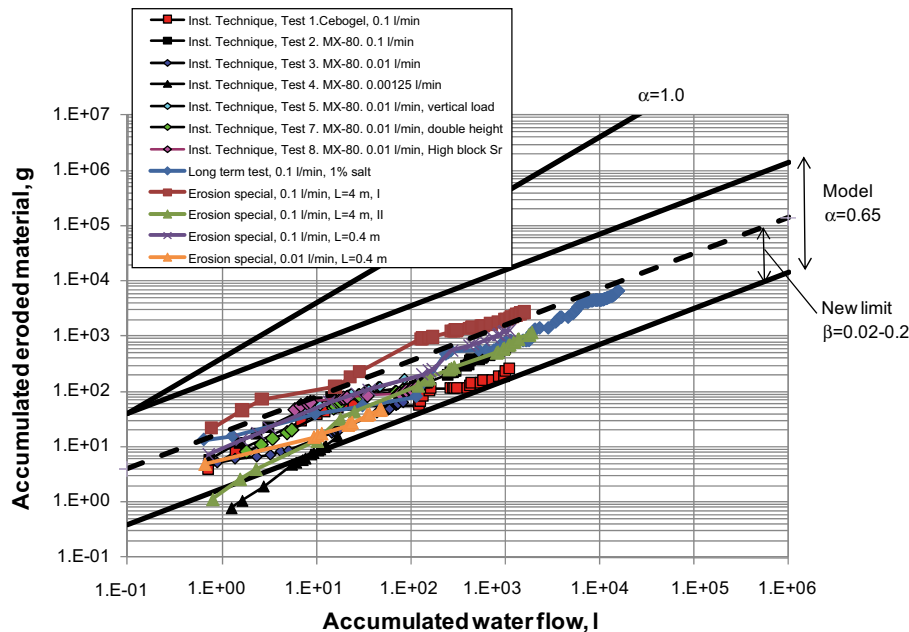

Figure 7-1. Illustration of Equation (7-2) together with results from different vertical upwards erosion tests on various bentonite materials. α corresponds to the inclination of the straight line in the logarithmic diagram (Sandén and Börgesson 2010). The figure suggests that the model can be limited to $\beta=0.02-0.2$ when the eroding water flows vertically upwards

Time perspective

The piping and erosion (excluding colloid erosion) takes place only before complete saturation, homogenisation and pore water pressure equilisation. The swelling of the bentonite is expected to seal the piping channels, but this is uncertain due to the low density and will be investigated. The water inflow must though not be so strong that the bentonite barrier has lost too much bentonite through erosion.

Handling in the safety assessment SR-PSU

The consequences of piping and erosion may be a loss of large quantities of bentonite if the time until water saturation and establishment of hydrostatic condition after emplacement of the bentonite is long and if the water flow is strong. However, the total amount of bentonite is large which reduces the effect.

The same type of estimation of material loss as was done for SR-Site will be done for the silo. The estimation will be based on new tests that should be performed. The self-sealing ability of the bentonite should also be investigated in order to understand the consequences of the erosion.

Timescales: The time after emplacement of bentonite until full saturation and establishment of hydrostatic conditions.

Handling of variables influencing this process: The water flow and the water pressure are the key variables for the piping. Erosion is also affected by the geometry of the bentonite filling. The effect of the salinity of the groundwater is also included in the description. All of these variables are included in the model that will be used.

Handling of variables influenced by the process: The consequence of extensive piping together with erosion would be a loss of bentonite density, which will be calculated for different cases.

Handling of uncertainties in SR-PSU

Given the adopted handling in the safety assessment SR-PSU as described above, the handling of different types of uncertainties associated with the process will be summarised.

Uncertainties in mechanistic understanding: Piping, erosion and subsequent sealing is a complicated process with many components, much depending on the hydraulic behaviour of the rock. The uncertainties are considerable regarding both the water flow in the rock and the ability of the buffer to resist these processes. Furthermore, it is not known if the bentonite seals such an inflow and if the channels are healed. The time required for the bentonite to seal (if it seals) is not known.

Model simplification uncertainties: The erosion model is so far based entirely on empirical data.

Input data and data uncertainties: The data used in the model will be derived mainly from new tests and to some extent experiences from earlier tests.

Adequacy of references supporting the handling in SR-PSU

The references are judged to be adequate and sufficient to support the handling in SR-PSU. All supporting references are either peer-reviewed articles or documents which have undergone factual review. Other references have been used for general background information, and not all of these have been peer-reviewed to the same standard.

7.3 Mechanical processes

7.3.1 Mechanical processes

Overview/general description

A number of mechanical processes may occur in the different barriers. The following is a list of processes in the **bentonite wall fill**:

- Stresses caused by the own weight of the bentonite.
- Hydraulic stresses.
- Swelling by wetting.
- Swelling pressure after wetting.
- Self-sealing of erosion damages.
- Deformation caused by stress changes.
- Creep deformations.
- Effects of concrete degradation
- Effects of displacements and fall out in the roof and walls of the rock vault.
- Indirect mechanical consequences of bentonite/cement interaction.
- Effects of freezing.
- Ion exchange, which leads to changed mechanical properties.
- Stresses caused by a swelling waste form.
- Stresses caused by gas formation.

When the bentonite along the vertical walls is installed (by free-falling) it is somewhat compacted and expected to yield an average dry density of 1,000–1,100 kg/m³. The density is additionally increased somewhat as the bentonite was filled layer wise until the entire 0.9 m gap between the rock surface and the silo had been filled all the way up to the top. This means that there is a small density gradient as a function of depth, with higher density at the bottom than at the top. See also Pusch (2003).

When the wetting starts the bentonite swells and either decreases its density, which takes place at the top of the bentonite filling, or exerts a swelling pressure on the surrounding. Due to the low density and the pore water chemistry the swelling pressure is rather low. The swelling pressure of the bentonite barrier along the silo walls is expected to be about 100 kPa but depends on the density and the chemical composition of the groundwater. Supplementary tests are in progress.

During wetting the damages and inhomogeneities of the bentonite filling will to some extent be healed by the swelling. The magnitude of the remaining inhomogeneities is however believed to be rather high due to the low density and the salinity of the groundwater. As mentioned earlier the swelling and self-sealing ability of this bentonite will be additionally investigated.

There may also be some creep deformations after full saturation and homogenisation but they are expected to be small.

The degradation of the concrete and possible rock fall out will also affect the bentonite filling. If the swelling pressure is high enough there will be a minimum of rock fall since the rock blocks will be kept in place. However, the degradation of the concrete by dissolution of cement may create voids and stresses that will affect the bentonite.

The following description illustrates the principles adopted for modelling of bentonite swelling from a geotechnical perspective. This approach does not address the underlying mechanisms that control the behaviour.

The swelling can be conceived as being caused by a force of repulsion between the montmorillonite layers. If there is a limited supply of water in a free specimen, the swelling is counteracted by a negative pressure in the porewater. If a specimen is water-saturated, i.e. all pores are filled with water; the swelling is counteracted by the formation of a negative pressure in the porewater in the water menisci on the surface of the specimen. The negative pore pressure is equal to the swelling pressure if no external pressure is applied. If the specimen is unsaturated, the water menisci develop inside the specimen as well. The negative pressure in the porewater is chiefly a function of the water ratio in the specimen, i.e. the quantity of water per unit weight of dry material. This negative pressure is called suction potential (see also Section 5.3.1). When water is added to an unconfined specimen, the water ratio increases and the repulsion forces and the suction potential decrease. This causes the specimen to swell until a new equilibrium is established with a lower internal swelling pressure. If the volume is kept constant, a portion of the internal swelling pressure is instead transferred to an external swelling pressure, which can be measured. When a specimen with constant volume is completely water-saturated and the porewater pressure is kept positive, the entire swelling pressure becomes an external pressure. At water saturation, the swelling pressure and the porewater pressure are independent quantities and give a total pressure that is the sum of the pressures (effective stress theory) according to Equation (7-3).

$$\sigma = \sigma' + Au \quad (7-3)$$

where

σ = total stress

σ' = effective stress = swelling pressure

u = porewater pressure

A = 1.0 for normal soils

The models used for describing the mechanical swelling and development of swelling pressure before full water saturation is reached are much more complicated and are described in e.g. the THM-report for SR-Site (Åkesson et al. 2010).

The gas pressure generated is expected to be low due to the sand filled gas-evacuation pipes in the lid.

The mechanical processes in the **bentonite/sand filling** in the bottom and in the top of the silo are similar in nature but less important due to the small bentonite content. The swelling pressure of 10/90 bentonite sand mixture is small and depends on density and pore water composition. See also Pusch (2003).

The **concrete** may also be affected by a number of mechanical processes:

- Stresses caused by the own weight of the concrete, the bentonite, the backfill and the waste packages.
- Hydraulic stresses.
- Deformation caused by stress changes.
- Creep deformations.
- Effects of concrete degradation caused by chemical processes.
- Indirect effects of displacements and fall out in the roof and walls of the rock vault.
- Stresses caused by corrosion of the reinforcement.
- Cracking.
- Effects of freezing.
- Stresses caused by gas formation.
- Interaction between the concrete and the waste packages.

In the long time perspective the concrete is expected to crack and be degraded by chemical processes. This may ultimately lead to a stack of residual products of mainly the ballast material with properties similar to sand.

The gas pressure generated is expected to be low due to the sand filled gas-evacuation pipes in the lid.

The **sand and cement-stabilised sand** on top of the silo are affected by the following mechanical processes:

- Stresses caused by the own weight and overlying materials.
- Settlement by bwetting.
- Hydraulic stresses.
- Deformation caused by stress changes.
- Creep deformations.
- Effects of cement degradation caused by chemical processes.
- Effects of displacements and fall out in the roof and walls of the rock vault.
- Stresses caused by gas formation.

The mechanical processes in the sand are identical to the ones described in the BMA described in Section 5.3.1. After degradation of the cement the cement-stabilised sand will have the same properties as the sand.

Before cement degradation the cement-stabilised sand will have properties reminding of poor concrete, with a shear strength that is high enough to withstand settlement and rock fall out. However, after cement degradation the filling will completely loose its strength and the remaining sand will settle by its own weight and by the weight of rock pieces that have come loose from the roof.

The gas pressure derived from outflowing gas through the pipes is expected to not be high since it will be able to escape through the rock and the tunnel system.

Dependencies between process and system component variables

Table 7-7 summarises how the mechanical processes influences and are influenced by all Silo variables.

Table 7-7. Direct dependencies between the mechanical processes in the Silo and the defined variables and a short note on the handling.

Variable	Variable influence on process		Process influence on variable	
	Influence present? Yes/No	Influence Description Handling of influence How/If not – Why	Influence present? Yes/No	Influence Description Handling of influence How/If not – Why
Geometry	Yes.	Included in the models.	Yes.	The geometry will be changed after concrete degradation, after rock fall out and after settlement of the sand. These cases will be handled.
Temperature	Yes.	Negligible.	No.	
Hydrological variables	Yes.	Included in HM models.	Yes.	Included in HM-models.
Mechanical stresses	Yes.	Included in HM models.	Yes.	Included in HM models.
Material composition	Yes, determines the properties.	Sensitivity analyses.	No.	
Water composition	Yes for the bentonite wall fill.	Will be considered.	No.	
Gas variables	Yes, gas pressure may be generated.	Will be modelled.	No.	

The geometry is important for the stresses in many respects. For example, the height of the silo affects the stresses, which increases with depth by the own weight of the materials. Also the width of the bentonite slot affects the stresses through the friction against the walls. These stresses may in turn affect the geometry especially after degradation of the concrete in the silo walls.

The temperature has a small influence on the mechanical processes unless the temperature is below zero, when it may cause freezing and thus strongly affect the different materials in the silo. See Section 7.1.2.

The hydrological variables such as water pressure and water compressibility and the mechanical stresses are included in the hydro-mechanical models. There is coupled interaction between water pressure and mechanical stresses. The swelling pressure of the bentonite is an important mechanical variable that is affected by the density and water composition.

The material composition has of course a big influence on the mechanical properties, not only due to the strong difference between the different types of materials bentonite, sand, concrete, but also within each group of materials. The swelling pressure of the bentonite in the slot is very similar to the swelling pressure of the KBS-3 reference buffer material (MX-80), but the mechanical properties depend on the smectite content and type.

The water composition also influences the swelling pressure and needs to be considered in the calculations.

Gas may be generated and have a strong mechanical effect on the barriers. There will be pipes installed in the lid of the silo, which are supposed to lead out gas and prevent strong mechanical interaction. See also Section 7.2.3.

Boundary conditions

The Silo has the rock as boundary. The different parts of the Silo have several boundaries.

Bottom backfill and bentonite wall filling

The bottom backfill and the bentonite wall fill have the rock as a mechanical fixed outer boundary. The inner boundary of the backfill is the concrete structure, which may interact mechanically with the backfill. The most important interactions are the effects of concrete degradation and the gas generation from inside the concrete structure. Rock fall from the walls may also affect the bentonite wall filling.

Concrete

The concrete has the backfill in the floor and in the roof and the bentonite wall fill as outer boundaries. The inner boundaries are the waste moulds. There is an interaction with the backfill and the wall fill (see above). There is also an interaction with the waste mainly through the gas production but also by the degradation of the concrete.

The sand and cement-stabilised sand on top of the silo

The sand has the rock as upper and side boundaries and the backfill as bottom boundary. The rock is a fixed boundary (except for occasional rock fall) while the bottom boundary may be displaced due to concrete degradation. There are also small parts that interact with the plugs and the wall fill.

Model studies/experimental studies

No studies with explicit purpose to investigate the mechanical processes in silo like structures have been performed, but sand fill and concrete structures have been investigated and used for engineering purpose in numerous tests and practices.

The bentonite wall fill has to some extent been investigated (Pusch and Karnland 1988, Pusch 2003). Investigations on similar materials have also been done for the spent fuel repository. See e.g. Börgesson et al. (1995). The bottom and top backfill have also been investigated and the properties of 10/90 bentonite/sand mixtures have been investigated for the spent fuel repository (Johannesson et al. 1999).

Natural analogues/observations in nature

See Section 5.3.1.

Time perspective

The entire life time will be handled. See handling in the safety assessment.

Handling in the safety assessment SR-PSU

There are some of the mechanical processes that may affect safety and will be included in the safety assessment. All subprocesses listed under overview/description will be commented on.

Bentonite wall fill:

- Stresses caused by the own weight of the bentonite.
- Hydraulic stresses.
- Swelling by wetting.
- Swelling pressure after wetting.
- Deformation caused by stress changes.
 - All these processes will be treated in a modelling exercise in order to frame the saturation time and derive a steady state situation after completed wetting and homogenisation.
- Self-sealing of erosion damages.
 - Also treated in Section 7.2.4.
- Creep deformations.
 - These are judged to be small but an estimation to check this may be done.
- Effects of concrete degradation.
- Effects of displacements and fall out in the roof and walls of the rock vault
 - These two processes may have impact on the wall fill and will be investigated.

- Indirect mechanical consequences of bentonite/cement interaction.
 - See Section 7.4.10 (Montmorillonite transformation).
- Effects of freezing.
 - See Section 7.1.2 (Phase changes/freezing).
- Ion exchange.
 - Will be analysed.
- Stresses caused by gas formation.
 - The gas pressure is expected to be small due to the gas pipes in the roof. See also Section 7.4.16 (Gas formation).

Backfill of sand on top of the silo

- Stresses caused by the own weight of the backfill.
- Settlement by wetting.
 - These processes will be analysed since the effect of a slot at the roof must be considered and included in the water flow modelling.
- Hydraulic stresses.
- Creep deformations.
 - These are small and will not be considered.
- Effects of cement degradation caused by chemical processes.
 - Will be considered so that if the sand is cement-stabilised the cement will ultimately be considered lost, i.e. there will only be sand left. See also Chemical processes.
- Effects of displacements and fall out in the roof and walls of the rock vault.
 - Will be analysed. Rock pieces in the roof may fall down and compact the sand fill, which leads to open slots at the remaining roof.
- Effects of freezing.
 - Will be analysed. See also “freezing” 7.1.2.
- Stresses caused by gas formation.
 - Will be analysed. See also Section 7.4.16 (Gas formation).

Concrete

- Stresses caused by the own weight of the concrete, the backfill and the waste packages
 - Will be neglected before degradation but after degradation these stresses may cause settlement and additional opening of the slot at the roof. This will be analysed.
- Hydraulic stresses.
- Creep deformations.
 - These are small and can be neglected.
- Effects of concrete degradation caused by chemical processes.
 - This is an important process that will have impact on the integrity of the silo and will be analysed.
- Indirect effects of displacements and fall out in the roof and walls of the rock vault.
 - Not very strong effects and may probably be neglected.
- Stresses caused by corrosion of the reinforcement.
- Stresses caused by a swelling waste form.
- Cracking.
 - These will contribute to the degradation. Analysed under chemical processes.
- Effects of freezing.
 - Will contribute to the degradation and will be analysed under freezing.
- Stresses caused by gas generation.
 - These will probably be small since the gas can escape through the pipes. See also Section 7.4.16 (Gas formation).

- Interaction with the waste packages.
- Deformation caused by stress changes.
 - Can be disregarded before the concrete degradation but may be important during and afterwards.

Bentonite/sand filling in the bottom and top of silo

The processes in the bottom filling are not very important for the safety and will only be analysed from measured settlement. However, the top filling will be mechanically affected by the concrete degradation and may thus settle. This should be analysed and the properties of the mixture intended for top filling should be tested.

The following processes are especially important (but also mentioned earlier):

The concrete will crack and completely change its properties with time. The degradation rate and rest product should be investigated in order to predict the change in properties with time. The concrete may be modelled as completely degraded with properties similar to sand after a certain time.

During the wetting and water saturation phase only the water saturation of the bentonite filling is expected to yield any mechanical consequences and will be analysed.

The homogenisation and self-sealing of voids and channels in the bentonite filling (caused by erosion) after water saturation will be studied. The low density and the chemical ground water composition make this process uncertain. Laboratory tests and modelling work will be done to investigate the self-sealing ability of the material.

The long term consequences of degradation of the concrete in the silo on the interaction with the bentonite filling will be analysed. The end product of the concrete may lose all its strength and create earth pressure on the bentonite filling. There may also be voids and loss of volume that may affect the density of the bentonite filling. It is also possible that the entire silo will settle and create a gap at the top.

The expected change in properties of the bentonite based barriers caused by the geochemical influence of the concrete will be considered.

Settlement of the cement-stabilised sand on top of the silo will cause an open space at the roof after degradation of the cement. The magnitude of this slot and the consequences on the other system components should be investigated.

Timescales: The entire life time of the silo will be included. The processes can be divided into two different time periods; before and after degradation of the cement. The time before degradation is rather stable and includes only the water saturation and the self-sealing and homogenisation of the bentonite filling as a critical process. Both periods will be included in the analyses.

Boundary conditions: The rock surface of the vault will be the mechanical boundary. The consequences of different mechanical processes like rock fall out and creep in this boundary will be analysed.

Handling of variables influencing this process: All the influencing variables in the table, except temperature, will be included in the analyses

Handling of variables influenced by this process: All the influenced variables will be included in the analyses.

Handling of uncertainties in SR-PSU

Given the adopted handling in the safety assessment SR-PSU as described above, the handling of different types of uncertainties associated with the process will be summarised.

Uncertainties in mechanistic understanding:

Bentonite wall fill

Mechanical properties and behavior of bentonite are in general well understood.

Backfill of sand on top of the silo

Mechanical properties and behavior of sand are well understood.

Concrete

The mechanical properties of the un-degraded concrete are well known and the mechanical processes well understood. The properties during and after degradation are more uncertain. A way to overcome these uncertainties may be to treat the concrete as completely degraded and turned into a sand heap after a certain time.

Backfill in bottom and top of the silo

The mechanical properties and behavior are well understood.

Model simplification uncertainties: The lack of knowledge of the properties of the degraded concrete may make it necessary to treat the concrete as completely degraded and turned into a sand heap after a certain time.

Input data and data uncertainties: See model simplifications. The properties of the bentonite wall fill and the backfill on top of the silo should be analysed in order to yield better data.

Adequacy of references supporting the handling in SR-PSU

The references are judged to be adequate and sufficient to support the handling in SR-PSU. All supporting references are either peer-reviewed articles or documents which have undergone factual review. Other references have been used for general background information, and not all of these have been peer-reviewed to the same standard.

7.4 Chemical processes

A general description of bentonite properties of relevance for chemical processes (mineralogical and porewater composition) is given in the SR-Site process report (SKB 2010a) for the bentonite buffer. This description is equally relevant for the bentonite barrier in the SFR Silo.

The following chapters focus on the bentonite barrier of the Silo. The sand in the cupola and especially the sand/bentonite in the bottom and top of the Silo are handled as part of the sections on bentonite, where relevant, as the processes are relatively similar and because these materials are part of the same system component. Processes in cement-based barrier materials are addressed in detail for the BMA vault (Section 5.4) and are not repeated for the Silo.

7.4.1 Advection and dispersion

Overview/general description

Advection and dispersion are the processes that describe how the transport of solutes or suspended materials (i.e. all dissolved species and colloids) is related to the transport of water. Specifically,

- Advection refers to dissolved or suspended substances being carried along with the bulk water flow;
- dispersion refers to solutes or suspended materials spreading out from the transport path expected to be followed by advection alone, this process is negligible in the Silo wall due to the short travel distance of water and is not discussed in further detail.

Obviously, these processes are closely related to the transport of water itself, which is discussed in detail in Section 7.2.2. Advection leads to a redistribution of solutes and colloids in the porewater and therefore influences the porewater composition.

For most dissolved species and colloids advective transport as such may be modified by various interactions with bentonite solids, this is discussed in Sections 7.4.3 and 7.4.5. Advection is of special importance during the saturation phase, when a net flow of water into the Silo wall and towards

the concrete barrier and waste can be expected. Advection can be expected to play a more important role in the sand parts in comparison to the bentonite and bentonite/sand parts.

Under saturated conditions, it is expected that hydraulic gradients decrease to a level where the transport of solutes or colloids in the porewater is dominated by diffusion in the bentonite and bentonite/sand parts, see Section 7.4.2. Exceptions may be sudden events that can cause local pressure changes in the porewater or increase hydraulic gradients near the repository, such as gas pulses or earthquakes.

Dependencies between processes and barrier variables

Table 7-8 summarises how the process advection influences and are influenced by all Silo variables. In addition, the handling of each influence in SR-PSU is indicated in the table and more thoroughly discussed in the text below.

Silo wall and pore geometry. The relation between geometry and the actual water transport is discussed in Sections 7.2.1 and 7.2.2. The geometry of the sand-filled parts will influence water transport. In case of the bentonite this will be relevant before full saturation and in case of sudden changes in pressure/gradients under saturated conditions. The transport of solutes does not influence physical pore geometry, but can have a significant influence on electrostatic effects and thus on overall pore characteristics (see Section 7.4.2).

Material, water and gas composition: Advective flow is relevant for these variables before saturation. This phase is not modelled, however. After saturation, transport is assumed to be dominated by diffusion (Section 7.4.2).

Table 7-8. Direct dependencies between the process ‘advection and dispersion’ and system component variables (dispersion not considered, see text above) and a short note on the handling in SR-PSU.

Variable	Variable influence on process		Process influence on variable			
	Influence present? Yes/No	Description	Handling of influence How/If not – Why	Influence present? Yes/No	Description	Handling of influence How/If not – Why
Geometry	No direct influence.	Characteristics of a porous medium, incl. pore geometry, affect hydrological variables and indirectly advection.	Geometry is included in the model.	No.	Transport of dissolved species or colloids does not influence (physical) geometry.	–
Temperature	No, but indirectly	through viscosity and density of water.	Negligible, not considered.	No.		–
Hydrological variables	Yes, determine the	transport of water and dissolved species.	Darcy flow included in geochemical model.	Indirectly through	water composition.	Neglected.
Mechanical stresses			–	No, but indirectly,	through water composition.	–
Material composition	No direct influence,	but indirectly through geometry: composition (especially sand vs. smectite content) influences cross-section available for transport.	Considered in hydrological and geochemical model.	Indirectly through	water composition: alteration of the bentonite before saturation depends on transport of solutes and thus on advective flow.	Processes occurring before saturation are neglected.
Water composition	Yes.	Water composition determines which solutes and colloids are transported before saturation.	Processes occurring before saturation are neglected.	Mainly through	transport of solutes and colloids before saturation.	Neglected, since diffusion is more important.
Gas variables	No direct influence,	H ₂ , CH ₄ and CO ₂ can influence water composition.	Included in geochemical model.	No direct influence.	Indirectly through dissolved concentrations.	Processes occurring before saturation are neglected.

Boundary conditions

Boundary conditions are those that control the transport of water and presence of solutes or colloids; i.e. the hydraulic gradient and water composition.

Model studies/experimental studies

As pointed out in the overview, advection is mainly relevant during the saturation process, which requires a net flow of water into the bentonite. Model and experimental studies regarding the hydrological properties of bentonite in this phase are discussed in Section 7.2.2.

A number of studies of SKB and other authors examining the advection of water in bentonite are available. Information about water flow during water uptake and saturation is given in these studies, as well as quantitative data describing water transport under different physico-chemical conditions (Karnland et al. 2006, 2009, Cho et al. 1999).

Particular attention is drawn to the LOT field-scale test at Äspö HRL, a long term test of bentonite saturation with groundwater. This test shows an increase of total ion concentration in the porewater in comparison to the originally present porewater due to the salinity of the saturating groundwater (Karnland et al. 2000, 2009).

Under saturated conditions, advection is not relevant. Exceptions may be situations with local pressure changes in the porewater, which could be caused by rapid changes in gas pressure or earthquakes.

Natural analogues/observations in nature

No natural analogue data are available. The most relevant observations may be related to the LOT field-scale test mentioned above.

Time perspective

Advection is relevant during the saturation process, which may take tens or hundreds of years. However, unsaturated conditions are not considered in SR-PSU.

Handling in the safety assessment SR-PSU

Advection (and dispersion) are mostly relevant for the saturation process. Dispersion is generally not very important over short transport distances. No modelling of these processes is done during the saturation phase, as the repository evolution before saturation is not considered explicitly.

Due to the expected low hydraulic gradients, advection can typically be neglected in comparison to diffusion after saturation. In case that higher hydraulic gradients occur due to sudden events such as earthquakes, the process has to be modelled for the description of solute and colloid transport.

Handling of uncertainties in SR-PSU

Uncertainties in mechanistic understanding

The basic understanding of the process is well developed, especially under saturated conditions and high hydraulic gradients. Uncertainties in mechanistic understanding are mostly relevant for the saturation phase. The validity of Darcy's Law to saturated conditions with (very) low hydraulic gradients is not established, but diffusion is expected to prevail under such conditions.

Model simplifications uncertainties

Unsaturated conditions: the process is not modelled explicitly.

Saturated conditions: if needed, the process could be modelled with a standard mass-transfer approach. The main uncertainty would concern the model parameters for handling the borders with the adjacent shotcrete and fractured rock.

Input data and data uncertainties

Unsaturated conditions: the process is not modelled explicitly.

Saturated conditions: it is assumed that diffusion will dominate.

7.4.2 Diffusion

Overview/general description

In general terms, diffusion describes the spread of solutes (or mobile suspended particles) through random motion from regions of higher concentration to regions of lower concentration, i.e. diffusive mass transfer takes place in the absence of a hydraulic gradient (in immobile water) and is driven by a concentration gradient of the diffusant.

The process leads to a redistribution of dissolved major pore water constituents as well as trace radionuclides in the pore water. Therefore, diffusion is a critical process for radionuclide migration in a bentonite barrier as well as in sand/bentonite mixtures, but also affects the pore water composition:

- Any ions or dissolved gases involved in geochemical alterations of the bentonite material (as well as any corresponding reaction products) have to be transported through the barrier by diffusion. Diffusion is strongly coupled to nearly all chemical processes in the barrier and is directly tied to the bentonite evolution under saturated conditions.
- After release from a waste package, the dissolved concentration of most radionuclides will be limited by the formation of radionuclide-bearing solid phases, including pure solids (such as oxides, carbonates) and solid solutions. Migration of the traces remaining in solution towards the geosphere is limited by the slow diffusive transport through the barrier.

Diffusion in a homogeneous porous medium is commonly described by Fick's first law (Equation (7-4)):

$$J = -D_p \varepsilon \frac{dC_p}{dx} \quad (7-4)$$

where: J is the diffusive flux, D_p the diffusion coefficient in the pore solution (pore diffusion coefficient), ε is the (physical) porosity and C_p the concentration of the diffusing species in the pore. The pore diffusion coefficient is related to the diffusion coefficient in free water by

$$D_p = D_w \frac{\delta}{\tau^2} \quad (7-5)$$

where: δ is the constrictivity (takes into account any narrowing or widening of pores along the diffusion path, typically set to unity) and τ is the tortuosity of the pores (takes into account increases in the length of the diffusion path because connections between two points are normally not straight). Equation (7-5) shows that pore diffusion is typically slower than diffusion in free water.

Phenomenologically, the diffusive transport (the changes in concentration of a diffusing species in time and space) is described by Fick's second law, which takes into account conservation of mass:

$$\frac{\partial C}{\partial t} = D_a \frac{d^2 C}{dx^2} \quad (7-6)$$

Distribution and diffusion coefficients are related as follows

$$D_a = \frac{D_e}{\varepsilon + \rho_d K_d} \quad (7-7)$$

where D_a is the apparent diffusion coefficient (m^2/s), ρ_d the clay dry density (kg/m^3); and K_d the mass distribution ratio (m^3/kg) representing the distribution of the radionuclide mass between dissolved and sorbed species (at position x). The term $\varepsilon + \rho_d K_d$ is often referred to as capacity factor.

As a porous medium, compacted clay possesses the unique feature of the permanent negative charge of the clay mineral surfaces. This is giving rise to a negative electrostatic charge in the clay pores, resulting in an anion deficit/cation excess in clay pores (see below and Section 7.4.9). This effect is also important in the 10/90% sand/bentonite beds but is not relevant in the sand parts of the Silo.

The deficit in anions and the corresponding excess of cations in bentonite needs to be taken into account in the description of the respective diffusion processes. This is discussed further in the section on model studies/experimental studies below.

Dependencies between processes and barrier variables

Table 7-9 summarises how the process diffusion influences and are influenced by all Silo variables. In addition, the handling of each influence in SR-PSU is indicated in the table and more thoroughly discussed in the text below.

Temperature influences diffusion processes but is expected to be low when radionuclide transport will occur.

Material composition: Pore characteristics are strongly influenced by the grain size of the clay and sand fraction. Electrostatic pore characteristics of the materials with a high smectite content depend on layer charge of clay minerals and pore geometry in the compacted state. The latter may be influenced by clay mineralogy and content as well as the presence of accessory minerals. These characteristics are viewed as part of the properties of a given bentonite and are considered in the selection of diffusion data obtained with different clay materials. Soluble accessory materials may further exert an effect through influencing the porewater composition.

Porewater composition: Water composition (ionic strength) directly influences electrostatic characteristics of the porespace. Further, different species of the same element can have different diffusivities. This holds for free water diffusivities, but in particular for diffusion in bentonite pores. Due to their interaction with the diffuse layer extending from negative clay surfaces, diffusivities decrease in the order anionic species < neutral species < cationic species. Thus, speciation could influence diffusion. However, the sum of all species of reactive elements typically appears as overall neutral under normal porewater conditions. This is also considered in the selection of diffusion coefficients.

Table 7-9. Direct dependencies between the process ‘diffusion’ and system component variables and a short note on the handling in SR-PSU.

Variable	Variable influence on process		Process influence on variable	
	Influence present? Yes/No Description	Handling of influence How/If not – Why	Influence present? Yes/No Description	Handling of influence How/If not – Why
Geometry	Yes. Pore geometry and porosity are of critical importance. The geometry of the barrier has no influence on the process.	Pore geometry and porosity are directly included in the conceptual diffusion model (see equations above).	No. Possibly indirectly through influence on porewater composition and swelling.	–
Temperature	Yes.	Effect of elevated temperature can be included by empirical equation.	No.	–
Hydrological variables	Yes, diffusion is affected by freezing.	Changes in effective diffusivity due to water freezing is included in the modelling.	No, but indirectly through influence on porewater composition and swelling	See Section 7.3.1 Mechanical processes.
Mechanical stresses	No, but indirectly through pore geometry.	See geometry.	No, but indirectly through influence on porewater composition and swelling.	See Section 7.3.1 Mechanical processes.
Material composition	Electrostatic pore characteristics depend on magnitude of charge and pore width.	Considered in data selection.	No, but indirectly through influence on porewater composition.	–
Water composition	Yes. Water composition influences electrostatic effects and concentration gradients.	Considered in data selection.	Through diffusive transport of solution constituents.	Included in the modelling of barrier chemical evolution, see Section 7.4.4.
Gas variables	No direct influence (saturated conditions assumed), H ₂ , CH ₄ and CO ₂ can influence water composition.	See water composition.	No direct influence. Indirectly through dissolved concentrations.	See water composition.

Boundary conditions

The relevant boundary conditions for the process occurring in the bentonite barrier and top/bottom parts are:

- The concentration of diffusants in space (gradients);
- the processes that influence diffusion pathways (alteration/cementation, montmorillonite transformation).

These are directly related to material and water composition and geometry.

The transfer of species from the bentonite barrier to the host rock can be viewed as the diffusion of dissolved species from the bentonite into flowing water in the near-field fracture network (equivalent flow rate, Q_{eq}). Q_{eq} depends on the geometry of the contact area, the water flux, the flow porosity and the water diffusivity.

Model studies/experimental studies

A very large number of experimental diffusion studies has been performed, see e.g. the data compilation in Yu and Neretnieks (1997) and in the SR-Site data report (SKB 2010d) for pertinent examples. Most of these studies concern bentonite or pure smectite, but some studies also used sand/bentonite mixtures of various compositions. For experimental reasons, most diffusion studies are performed as transient in-diffusion experiments, which yield D_a . D_a is a lump-sum representation of all processes relevant for radionuclide migration, including diffusion and sorption.

Effective diffusion coefficients D_e , which are the required input parameter for the SR-PSU safety assessment, are commonly obtained in steady-state through-diffusion studies. Due to the long experimental timeframes required to obtain through-diffusion data, such experiments are largely restricted to mobile tracers (alkaline and alkaline earth elements, HTO, anions). Yu and Neretnieks (1997) provide an overview of different experimental methods and how the results can be interpreted in view of different experimental techniques and potential problems (e.g. effects of metal filters). It is noted in this respect that the extraction of diffusion coefficients from experiments invariably involves fitting of parameters in diffusion equations (see above) to experimental data.

While the interpretation is relatively straightforward in case of inert and uncharged tracers (HTO), it is more complicated in case of charged and/or reactive tracers, due to their interaction with the permanent clay negative charge and porewater constituents. Anionic and cationic tracers show a diffusion behavior that can be described as anion exclusion and enhanced cation diffusion. As these phenomena concern a number of mobile and safety-relevant radionuclides, they are discussed in more detail below.

Enhanced apparent cation diffusion

It has been observed that the apparent diffusion coefficient (D_a) for cations and their respective distribution coefficient (K_d) do not correspond as expected; i.e. that D_a has been higher than expected from K_d values and traditional porewater diffusion–sorption theory. It is, however, important to recognise that consistency among D_a and K_d is only to be expected for self-consistent datasets, i.e. both D_a and K_d need to correspond to the same set of conditions (in particular to the same porewater composition). Thus, several of the discrepancies between D_a and K_d observed in the past (e.g. Yu and Neretnieks 1997) can be traced to the fact that incompatible conditions have been compared. In particular, D_a values that invariably correspond to the porewater composition in compacted bentonite have been compared directly with K_d values from batch experiments involving typically much more dilute solutions. Given that K_d values are derived for relevant porewater conditions, sorption and apparent diffusion coefficients for most elements agree within the overall data uncertainty (Ochs et al. 2003, Bradbury and Baeyens 2003).

Nevertheless, there are cases where it seems clear that certain cations may have apparently enhanced diffusivities, which must be taken into consideration in safety assessments. The presently available information suggests that these cases are largely restricted to mobile and cationic elements: alkaline ions, and possibly also alkaline earth ions, see the section on model concepts below and the respective sections in the SR-Site and SR-PSU data reports (SKB 2010d, **Data report**).

While different models of the porespace of compacted clays have been developed (see below), enhanced cation diffusion can be explained by a cation excess in the electrical double layer (EDL) extending from negatively charged clay surfaces into the pore space (Kato et al. 1995, Sato et al. 1995, Ochs et al. 2001, Wersin et al. 2004). Note that cation excess (as well as anion deficit, see below) have been well established in clay chemistry (see e.g. van Olphen 1991) and that the mean cation excess/anion deficit in the EDL corresponds to the differences in cation/anion concentrations in compacted clay pores as calculated through Donnan equilibrium (Karnland et al. 2005).

Because these electrostatic effects increase the dissolved concentration of cations in the pore space in comparison to the corresponding (external) bulk solution and in comparison to neutral and anionic species, diffusing cationic tracers have higher concentration gradients and therefore higher diffusion rates than would be expected in the absence of the electric charge effects in the clay pores. Note that this holds for cations that accumulate in the diffuse layer, thereby retaining their mobility parallel to (but not perpendicular to) a mineral surface; but does not hold for specifically (i.e. chemically) sorbed surface species formed at surface complexation or ion exchange sites. This means that for an evaluation of diffusive transport in compact clays, the simple accumulation in the counter-ion swarm of an electrical field near a surface and actual sorption (represented by K_d) need to be distinguished.

Alternative explanations have been put forward in the past. While presumably based on the same underlying process, the so-called surface diffusion mechanism (Muurinen 1994, Eriksen and Jansson 1996, Yu and Neretnieks 1997) makes a direct link with actual sorption by introducing an additional surface diffusion coefficient that is multiplied by K_d . As pointed out above, however, there is no reason to assume that (specifically) sorbed species retain their mobility. A reduction of K_d in highly-compacted bentonite due to a decreased accessibility of surface sites has also been considered as a possible explanation for the disagreement of diffusion data with batch K_d values (Wanner et al. 1996), but it was shown by Kato et al. (1995) that the entire physical porosity in compacted bentonite is accessible.

Anion exclusion

With increasing density, the pore width in clays decreases, which may cause a superimposition of the electrical double layers between the negatively charged pore walls, i.e. the diffuse layers in compacted clay are truncated and no free (bulk) porewater exists, see e.g. Ochs et al. (2001) and Wersin et al. (2004). The anion deficit in the diffuse layer explains the apparent anion exclusion effect: diffusing anionic tracers have lower concentration gradients, and therefore lower diffusion rates than would be expected in the absence of the electric charge effects in the clay pores. While the term anion exclusion is accepted for the present report, it needs to be made clear that it refers to exclusion in terms of concentration (EDL anion deficit or Donnan exclusion) and does not refer to exclusion due to restrictions in physical pore width. This means that the underlying concept is compatible with different concepts of porosity and type of pores in compacted bentonite (see below). The effect of anion exclusion becomes generally less at high salinities, because high ionic strength leads to a depression of the diffuse layer (Stumm and Morgan 1996), while in sand–bentonite mixtures anion exclusion is negligible.

Models of diffusion and pore characteristics.

Different model concepts have been developed to explain the diffusion behavior of cations and anions. This is related to uncertainties regarding the micro-/nanostructure of compacted clays and the nature and distribution of pore types. The different model concepts can be grouped into single- and multi-porosity models.

The single-porosity models all consider a more or less homogeneous porespace to be present in compacted clay:

- The conventional pore model (as typically applied to performance assessment calculations) does not take into account the electrostatic effects. The abovementioned diffusion of simple anions and cations is handled by a reduction of accessible porosity and a lower D_e for anions and an increased D_e for cations (see e.g. **Data report**, Ochs and Talerico 2004). It is a pragmatic approach but needs to invoke two mechanisms.

- Donnan-equilibrium models (Birgersson and Karnland 2009) treat compacted smectite clay like a homogeneous solution containing immobile negative charges (clay platelets) inside a semi-permeable membrane. This model successfully describes swelling pressure development as a function of compaction and salinity, as well as the diffusion of some cations and anions, but the link to sorption is not straightforward.
- Sato et al. (1995) and Ochs et al. (2001) developed a diffuse layer model considering the distribution of ions between bulk solution, diffuse layer (extending from planar surfaces) and ion exchange (or surface complexation) sites. The model is able to describe enhanced cation diffusion and anion exclusion in compacted bentonite based on cation excess and anion deficit in the diffuse layer, but used significant simplifications (such as not explicitly accounting for the truncation of the diffuse layer). These are partly remedied in a modified version used by Tachi et al. (2009, 2010).

Recently, several multi-porosity models have been formulated, which generally consider diffusion in the different porosity compartments free water, diffuse layer water and interlayer water, each with their own physicochemical properties, see e.g. Appelo and Wersin (2007) and Bourg et al. (2006). All of these models are based on the concept of electrostatic exclusion of anions from part of the total porosity, leading to lower diffusion porosities and diffusion coefficients relative to neutral species. The enhanced diffusion of cations on the other hand is taken into account by different mechanisms:

- Appelo and Wersin (2007) assume an increased diffusional gradient of cations between the diffuse layer and the free water;
- Bourg et al. (2007) consider the existence of an additional diffusion pathway in the interlayer;
- Gimmi and Kosakowski (2011) assume an increased mobility of cations close to the surface, i.e. they use a concept that is close to the surface diffusion model as described in Yu and Neretnieks (1997).

Natural analogues/observations in nature

The usefulness of natural analogues for evaluating diffusion behaviour is very limited due to the large uncertainty with regard to the conditions that existed in the past. Natural analogues can illustrate that diffusive transport in clays is greatly slowed down for many sorbing radionuclides (e.g. Smellie and Karlsson 1996).

Time perspective

Diffusion processes in the barrier material are relevant on all timescales, as slow diffusion is very important in delaying, reducing or preventing releases of radionuclides. With respect to the overall repository evolution, diffusion is a fast process.

Handling in the safety assessment SR-PSU

Before saturation: The process is neglected since advection dominates.

After saturation: The process is included (for major ions) in the scenario-specific modelling of the barrier chemical evolution, see Section 7.4.4. The process is treated in a simplified way with identical diffusivity for all elements in the barrier chemical evolution.

The process is also included in the modelling of radionuclide transport, see Section 7.5.2. For the treatment of radionuclide diffusion, element-specific effective diffusivities are used together with corresponding porosities (see the **Data report** for the definition of data and associated uncertainties).

Handling of uncertainties in SR-PSU

Uncertainties can be expressed by bounding values for D_e and ϵ (see input data and uncertainties below).

Uncertainties in mechanistic understanding

Because of the relative experimental inaccessibility of bentonite pores, diffusion data are of macroscopic nature and are not well suited for any mechanistic interpretation. On a mechanistic level, the main shortcomings probably lie in the understanding of electric double layer (EDL) properties as well as porewater structure and their influence on diffusion (and sorption) processes in compacted bentonite. This is particularly true for high densities that lead to an overlap of opposing EDLs.

The processes of enhanced cation diffusion and anion exclusion have been discussed above. The processes giving rise to these phenomena are the establishment of a cation excess and an anion deficit in the diffuse layer extending from a negatively charged mineral surface. Thus, these phenomena are caused by effects of enhanced or diminished ion concentrations in the volume of the porespace, rather than actual available porosity or different diffusivities. However, several approaches can be used to include the effects of this process in the diffusion equation that is used to define D_a .

Transport due to the presence of an electrical field is not considered. It is assumed to be negligible compared to a concentration gradient.

Model simplifications uncertainties

Diffusion is represented in a simplified way, through the use of selected constant effective diffusion coefficients and diffusion-available porosities. In that sense, the diffusion input parameters have to be viewed as conditional; i.e. their application will only be valid under the conditions considered in data derivation. Therefore, uncertainties will be related to the selection of consistent conditions. Fortunately, the actual diffusion process under steady-state conditions (as represented by D_e) is largely independent of chemical conditions. See the **Data report** for a discussion of data selection.

In principle, this situation could be resolved by directly including diffusion processes in the model used for consequence calculations, which would require a THMC model approach. However, in addition to the great difficulties still associated with coupling THM processes on the one and C processes on the other hand, the present state of the art of quantifying radionuclide diffusion in compacted bentonite does not allow this. To date, semi-mechanistic models have been proposed and tested only for a few elements (Cs, Sr, anions; see above). At the same time, in case of many relevant radionuclides there is a clear lack of systematic data from through-diffusion experiments that would be needed to develop further diffusion models in a meaningful way. Except in the case of fairly mobile elements, through-diffusion experiments typically cannot be performed within a reasonable timeframe.

While the abovementioned models are clearly simplified and still under discussion, they appear to be quite robust as shown by the results of model predictions that are consistent with experimental data for several bentonites and over a range of densities. Based on the present evidence, it is expected that the direct use of diffusion parameters will not introduce significant additional uncertainties.

Input data and data uncertainties

Input data to SR-PSU are effective diffusivities (D_e) and diffusion-available porosities (ϵ) to be directly used in consequence calculations. Data and uncertainties as a function of bentonite density are given in the separate **Data report**. Dependence on bentonite density and bentonite-type, expected ionic charge of diffusing species, ionic strength and temperature is considered in selecting diffusion constants for transport of radionuclides. For the treatment of diffusion within the bentonite chemical evolution, see Section 7.4.4.

Uncertainties can be expressed by bounding values for D_e and ϵ .

7.4.3 Sorption (including ion-exchange of major ions)

Overview/general description

Radionuclides and major ions in the pore water of the bentonite barrier system can be bound to the surfaces of the barrier material in several ways (see below). Together, these processes are termed sorption and are of essential importance for the function of the bentonite barrier:

- They drastically affect the mobility of most radionuclides,
- They have also a strong influence on the transport of major ions which is in turn related to the evolution of the bentonite.

The principal mineral in bentonite and in bentonite/sand mixtures is montmorillonite, which possesses a very high specific surface area and consists of octahedral alumina sheets sandwiched between tetrahedral silica sheets (2:1 clay). Such clay minerals feature two distinctly different types of surfaces, a planar layer surface and an oxide-like edge surface. In comparison, quartz only features the typical Si-oxide surface. On these surfaces, two main types of sorption processes take place (e.g. Sposito 1984, Stumm and Morgan 1996), as detailed below. Because quartz possesses no layer-type surface and because it has a much lower specific surface area than clay minerals, the contribution of quartz to overall sorption is typically negligible in comparison to bentonite.

- The siloxane ('layer') surfaces of clay minerals are *permanent charge surfaces*. These charges derive from isomorphous substitutions, which result in a constant negative surface charge. This charge is partly compensated by cations located at (and bound to) the clay surface (e.g. at the di-trigonal cavity (Sposito 1984)), and partly by cations simply accumulated in a counter-ion swarm. The latter is equivalent to an electrical double layer extending from the surface (see Section 7.4.9). Macroscopically, sorption takes place when compensating ions are exchanged. *Ion exchange models* of the site-binding type have been used in soil science since the first quarter of the 20th century. Several formalisms have been developed to correct for activity changes of the exchanger as a function of the composition of the charge-compensating ions. The most common are the equivalent fraction (Gaines-Thomas, GT) and mole fraction (Vanselow) models.
- The edge surfaces of clay minerals and the surfaces of oxide minerals are *variable charge surfaces*. They carry a net positive or negative surface charge depending on the species sorbed to their surfaces (potential-determining ions), often involving surface-bound OH⁻ groups. *Surface complexation and ligand exchange models* were established by Stumm, Schindler and co-workers in the 1970s by extending proton-binding and metal coordination chemistry in a rigorous fashion to surface chemistry. To account for the electrostatic field, the mass laws for surface equilibria often include an electrostatic correction term. The scientific basis for these corrections is derived from Electrical Double Layer (EDL) theory. The clay edge exposes surface Al–OH and Si–OH groups, while quartz surfaces only feature the latter. Because Si–OH groups are fairly acidic, most elements and ligands have a higher affinity for the Al–OH surface groups.

Ion exchange is the typical sorption mechanism for alkali, and alkaline-earth elements, as well as transition metals and actinide/lanthanides at low pH values where positive species are predominant. Surface complexation is generally the more relevant process for all reactive elements (transition metals, actinides, lanthanides, reactive anions such as carbonate). Note that both ion exchange and surface complexation take place simultaneously, but at different surfaces.

Bentonite has a significant pH buffering effect, due to the reactions of H⁺ ions with the clay surface. H⁺ ions are bound to the edge sites of clays (as well as to ion exchange positions at very low pH), which means that pH changes can occur due to surface chemical reactions. Due to its ampholytic properties, i.e. ability to both receive and donate hydrogen ions, montmorillonite can counteract external changes in pH (Wanner et al. 1992).

Reversibility of sorption is a fundamental paradigm with regard to:

- Quantitatively expressing solid/liquid partitioning of solutes through K_d values.
- The use of K_d values in transport models (for dissolved radionuclides and any other solutes).

In the absence of any evidence to the contrary, a fundamental and widely accepted principle is that cation exchange and surface complexation on clay and oxide-type minerals are reversible, which follows directly from analogies with corresponding exchange and complexation reactions in homogeneous aqueous solutions; see e.g. Sposito (1981, 1984) and Stumm and Morgan (1996). Accordingly, most studies concerning surface reactions on these minerals focus on sorption, whereas much fewer studies have been published that systematically investigate the degree of reversibility in sorption experiments.

However, there are several examples documented in the literature where some type of irreversibility was observed. Below, in the Model studies/experimental studies section, several examples are examined and their relevance with respect to radionuclide sorption on clays is evaluated. While this discussion is not based on an exhaustive review of the literature, it shows that sorption on clays and clay-like substrates is typically found to be reversible if the experimental boundary conditions are carefully evaluated.

In addition to clay minerals, the accessory minerals in bentonite may also be relevant in certain cases. With regard to the predominant surface complexation and ion exchange, montmorillonite is clearly the most important bentonite constituent. On the other hand, carbonate minerals (mainly calcite) can form solid solutions (see Section 5.4.3) with certain species, offering a different sorption mechanism that may be relevant in a few cases. Possible examples are:

- The sorption of otherwise very weakly sorbing oxo-anions (such as selenate) that show sufficient similarity to the carbonate ion to fit into calcite crystals (Curti 1997).
- The overall partitioning of ^{14}C , which, however, is an isotope exchange with stable carbon rather than an actual sorption process.

The relation of sorption processes to radionuclide transport is given in Equation (7-8). In this context, sorption is normally quantified using a linear equilibrium relationship between the sorbed concentration of a radionuclide and its corresponding concentration in solution, yielding the distribution coefficient K_d :

$$K_d = \left(\frac{C_{init} - C_{equil}}{C_{equil}} \right) \frac{v}{m} = \frac{q}{C_w} \quad (7-8)$$

where:

C_{init} is the initial aqueous concentration of a key element [mol/m^3] as measured in the reference solutions without solids.

C_{equil} is the final equilibrium aqueous concentration of this element [mol/m^3].

C_w is the concentration in solution.

v is the volume of the solution used for a batch experiment [m^3].

m is the mass of the solid phase used for a batch experiment [kg].

q is the sorbed concentration as mass per weight unit of solid phase.

Dependencies between processes and barrier variables

Table 7-10 summarises how the process influences and are influenced by all Silo variables. In addition, the handling of each influence in SR-PSU is indicated in the table and more thoroughly discussed in the text below.

Geometry: In case of bentonite, an indirect influence of pore geometry on sorption may be possible through influencing the electrostatic effects near the clay surfaces. However, this effect is much more dependent on the degree of compaction than on geometry.

Temperature: Most experiments have been carried out at room temperature, and not enough sorption data as a function of temperature are available to clearly evaluate temperature effects. In general, a decrease of sorption with temperature would be expected, but some isolated studies (e.g. Lu et al. 2003) indicate the opposite. Thus, an increase or decrease of the temperature is potentially of importance for sorption, but the effects within the temperature range expected in the repository are deemed to be covered with good margin by other uncertainties.

Material and water composition: The two most important variables with regard to radionuclide sorption and exchange of major ions are the bentonite (or sand) and porewater composition. The smectite content of bentonite and bentonite/sand mixtures is directly related to the amount of available sorption sites and their specific properties. The porewater composition is the result of the interaction of incoming water with bentonite (ion exchange, mineral equilibria) and, in turn, exerts a major influence on radionuclide sorption. Quartz sand alone exerts only a minor influence on water composition.

On the other hand, K_d as a quantitative measure for the magnitude of sorption is clearly independent of the solid/water ratio and, therefore, of the bentonite density (given that the solution composition remains constant). Under a given set of conditions, sorption increases if the amount of bentonite (i.e. the solid/water ratio) is increased. By expressing sorption through K_d (see Equation (7-8)),

Table 7-10. Direct dependencies between the process ‘sorption’ and system component variables and a short note on the handling in SR-PSU.

Variable	Variable influence on process		Process influence on variable	
	Influence present? Yes/No Description	Handling of influence How/If not – Why	Influence present? Yes/No Description	Handling of influence How/If not – Why
Geometry	No, sorption is a molecular-level process not influenced by macroscopic geometry.	–	No, but pore geometry may be indirectly affected through influence on porewater composition and swelling of bentonite.	–
Temperature	Yes. Influence of temperature on sorption must be acknowledged, but effect is not clear.	Neglected. Could be included in K_d selection in case of available data.	No.	–
Hydrological variables	No, but indirectly through porewater composition.	See water composition.	No, but indirectly through influencing porewater composition and swelling of bentonite.	Neglected.
Mechanical stresses	No.	–	No, but possibly indirectly through influence on porewater composition and swelling of bentonite.	Neglected.
Material composition	Yes.	Considered in data selection.	Yes.	Included in geochemical model.
Water composition	Yes.	Considered in data selection.	Yes.	Included in geochemical model.
Gas variables	No direct influence, H_2 , CH_4 and CO_2 can influence water composition.	See water composition.	No direct influence. Indirectly through dissolved concentrations.	Included in geochemical model.

which includes the solid/water ratio, this effect is already taken into account. It appears from diffusion experiments that the apparent K_d is influenced by density, for example the K_d for caesium is halved when the density of the water-saturated system changes from 1,300 to 1,950 kg/m³. However, this can be entirely attributed to an increase of ionic strength caused by the dissolution of impurities from an increasing mass of bentonite, and is easily reproduced by simple thermodynamic sorption models (Ochs et al. 2001). This effect is mostly relevant in case of dilute groundwaters.

Boundary conditions

The process (more specifically its extent) depends on bentonite or bentonite/sand and on porewater composition. The relevant boundary conditions in order to treat the process quantitatively are therefore those of the transport processes that control the exchange of solutes between the porewater and the water in its adjacent components, i.e. the boundary conditions of the processes diffusion and advection.

Model studies/experimental studies

Ion exchange and surface complexation are well-established processes based on a large amount of experimental sorption data as well as spectroscopic investigations. At least for simple systems, quantitative thermodynamic models exist for calculation of sorption (K_d) as a function of conditions, such as pH, carbonate concentration, radionuclide concentration etc (NEA 2005, 2012).

Similarly, the effects of sorption/exchange processes on bentonite and porewater properties have been investigated in a number of experimental and modelling studies (see Section 7.4.4). Thermodynamic models are available for describing the exchange of major cations between external water and bentonite pores, as well as the pH-buffering by edge site protolysis equilibria.

As a result of the use of K_d to quantify sorption, reversibility of cation exchange and surface complexation are of concern. Based on the nature of these reactions, reversibility can generally be expected (Stumm and Morgan 1996). However, comparatively few studies have systematically investigated reversibility, and in some cases appeared to indicate irreversibility of sorption in case of bentonite. Because of the relevance of this issue, some typical examples are discussed:

- Some of the classical cation exchange experiments can be interpreted to indicate some degree of hysteresis. Verburg and Baveye (1994) showed that this is not due to the exchange process but to a change in clay aggregation in such experiments. This is caused by the nearly complete change of the supporting electrolyte solution (e.g. from NaCl to CaCl₂). This is very different from the conditions relevant in the context of radionuclide migration, where only trace cations are of concern.
- Similarly, it has been shown that the apparently non-reversible sorption of Cs on some types of clays is due to a change in the structural properties of the clay (collapse of clay layers) induced by extremely high surface loading of Cs (Grütter et al. 1990). They also show that this is only possible in case of clays with a higher structural charge than smectite and in case of very high surface loading of Cs.
- Another reason for apparent irreversibility is the formation of surface precipitates due to high radionuclide concentrations. O'Day et al. (1994) observed (by EXAFS) multinuclear surface complexes of Co on kaolinite at high surface loading (just below complete monolayer coverage), whereas only mononuclear surface complexes were observed at low coverage. Kinetic aspects are also important in this respect: Scheidegger and Sparks (1996) showed that with sufficiently long equilibration times (<1 year), Ni sorbed onto clay as well as Ni forming a surface precipitate on the clay surface could be desorbed completely.
- Finally, kinetic aspects and the gradients leading to desorption need to be kept in mind. For example, Scheidegger and Sparks (1996) showed that Ni adsorption and surface precipitation on clays is reversible within similar timeframes, and that kinetics depend strongly on the gradients imposed. Cui and Eriksen (1995) showed that the sorption of Sr is completely reversible with regard to the concentration, pH change (pH 4 to ca 12.5 and back), and Sr isotope exchange within 30–100 days.

Natural analogues/observations in nature

Natural analogues offer evidence that migration of sorbing radionuclides occurred only over limited distances away from a source in clay-rich substrates (Smellie and Karlsson 1996). For the effects of sorption/ion-exchange reactions on bentonite properties, see Sections 7.4.4 and 7.4.10.

Time perspective

Sorption processes in the bentonite barrier are relevant for the whole assessment period. They can generally be considered as very fast in comparison to other processes. With regard to their role in bentonite alteration, the transport rate into the bentonite and in the bentonite pores will control the extent of sorption/exchange processes. The timescales that are of interest are dependent on the half-life of the individual nuclide in comparison to the overall travel time through the barrier.

Handling in the safety assessment SR-PSU

Before saturation: The process is neglected.

After saturation:

- Ion exchange is included in the scenario specific modelling of the chemical evolution of the barrier, see Section 7.4.4.
- After radionuclides are released from the waste package, sorption is included in the modelling of radionuclide transport, see Section 7.5. Sorption is quantified through element-specific K_d values derived for specific conditions (see the **Data report** for the definition of data and associated uncertainties).

Dependence on bentonite properties as well as composition and pH of the porewater in the barrier, as resulting from bentonite-water interaction, are considered in selecting sorption constants for radionuclide transport. The sand fill on top and the bottom and top beds are not considered. Because of the conditional nature of sorption constants, the selected data are derived for several sets of relevant safety assessment conditions. Temperature effects are not considered explicitly, but the effects within the temperature range expected in the repository are deemed to be covered with good margin by the uncertainties associated with the selected K_d values. Further, the influence of ion exchange and surface acid-base equilibria on porewater composition is also taken into account in the derivation of radionuclide K_d values.

The fundamental assumption of reversibility can be confirmed if:

- Similar or longer timeframes are considered for sorption and for desorption (considering that desorption will often be somewhat slower than sorption).
- There is a sufficient concentration gradient or chemical driving force for desorption (e.g. dilution, change in chemical conditions, presence of a competing sorbent).

Exceptions to this are mainly reactions that lead to incorporation instead of sorption. For the case of clays, the main mechanism would be the collapse of certain expandable 2:1 layer structures at high surface loading. However, this is not relevant for smectite clays, due to their relatively small permanent layer charge. Based on the present information, there is no reason to assume irreversibility of sorption reactions of radionuclides on clays under relevant conditions.

Handling of uncertainties in SR-PSU

Uncertainties in radionuclide sorption can be handled by bounding K_d values. Such values address the uncertainty in the magnitude of sorption at a given set of conditions. If uncertainty in the conditions themselves has to be addressed, sets of K_d values can be derived for alternative or bounding conditions.

Uncertainties in the exchange behaviour of major ions (as considered in the modelling of porewater composition and bentonite alteration) would have to be directly linked to the respective ion exchange constants.

Uncertainties in mechanistic understanding

Detailed conceptual and mechanistic understanding, as well as a large quantity of measurement data, exist for simplified systems. Detailed reviews of sorption processes, underlying experimental data, model results, as well as the relation to performance assessment can be found in e.g. NEA (2005, 2012) and Davis and Kent (1990). In particular, it has been shown that thermodynamic sorption models developed for purified Na-montmorillonite can be applied to Ca-montmorillonite (Bradbury and Baeyens 1999), and that such models give results for compacted bentonite that are compatible with diffusion data (NEA 2012, Ochs et al. 2003). To date, there is no doubt that sorption processes are well understood in a quantitative way and in terms of thermodynamic description, and that this understanding can be used to make educated predictions of K_d values to be used in safety assessment calculations.

However, there still is a lack of data for understanding and predicting the influence of some important variables (such as dissolved carbonate concentration) on the sorption of some radionuclides, and this has to be taken into account in evaluating uncertainties of K_d values (**Data report**). In case of some radionuclides, the underlying thermodynamic database is insufficient to quantitatively evaluate their behaviour for different conditions.

Model simplification uncertainties for the above handling in SR-PSU

The K_d concept for radionuclide transport modelling is basically justified under conditions far from surface saturation (i.e. in the linear sorption range), which can be expected in the case of diffusion-limited radionuclide migration in a bentonite barrier. At the same time, it is clear that a K_d is a highly conditional parameter in terms of chemical conditions (pH, ionic strength, etc) and has to be derived for each set of conditions. This is addressed in detail in the **Data report**. As long as the bentonite barrier can be expected to represent a homogeneous geochemical compartment, no spatial variability needs to be taken into account.

Input data and data uncertainties for the above handling

Input data for modelling radionuclide transport are K_d values to be directly used in consequence calculation, as well as the associated uncertainties. K_d values need to be defined for each set of geochemical conditions, and considering all relevant oxidation states of radionuclides.

Input data to geochemical models are the ion exchange constants (or selectivity coefficients) defining the exchange of major cations.

7.4.4 Alteration of impurities

Overview/general description

This process is only relevant for the bentonite in the barrier and top/bottom beds. The bentonite used for the barrier in the Silo consists mostly of smectite, including the suite of cations on the exchanger surface, but contains also accessory minerals as well as impurities. During and following the saturation with water in the repository environment:

- The exchangeable cations will equilibrate with aqueous phase.
- Accessory minerals as well as impurities can be dissolved and possibly re-precipitated depending on the prevailing conditions (see also Section 7.4.6).
- Precipitation (formation) of new minerals may also take place, see Section 7.4.6.
- Smectite can be transformed (see Sections 7.4.10 and 7.4.11).

The type of mineral alterations taking place and their effect on the overall performance of the barrier depends on the interaction of the bentonite with external solutions. In the Silo, the bentonite is sandwiched between the concrete Silo wall and the shotcrete lining of the host rock wall. The minerals near the bentonite/concrete interface will be exposed to a (highly) alkaline fluid. While some minerals, such as calcite, are expected to be stable under these conditions, especially the silicate minerals will become unstable and react in part to form new solid phases.

The present process focuses on the bentonite–water equilibration involving exchange reactions coupled with solubility equilibria of relatively easily soluble impurities and accessory minerals. The chemical reactions considered are mainly ion exchange (Section 7.4.3) and aqueous speciation coupled to solubility equilibria (Section 7.4.8). Further mineral alteration reactions are treated under separate processes in the sections indicated above.

The main potential effects of the present process on the bentonite barrier are the cementation of the barrier (i.e. precipitation of large amounts of accessory minerals in specific parts of the Silo wall, see also Section 7.4.14) and changes in the montmorillonite surface composition that can affect the swelling capacity of the bentonite. The concomitant changes in the chemical composition of the porewater are assumed to be minor, because the solution will have been already mineralised by the cementitious barrier components. On the other hand, some of the reactive porewater constituents will be used up by interaction with the bentonite, thus being prevented from migrating very deep into the barrier (see Section 7.4.10).

Dependencies between processes and barrier variables

Table 7-11 summarises how the process influences and are influenced by all Silo variables. In addition, the handling of each influence in SR-PSU is indicated in the table and more thoroughly discussed in the text below.

Geometry: The solid/water ratio (i.e. the mass of bentonite) has an important effect on the process and is considered in the modelling. The actual geometry of the barrier is not relevant under saturated conditions. The saturation is not explicitly considered.

Boundary conditions

Initial boundary conditions are the bentonite and water composition. The relevant boundary conditions in order to treat the process quantitatively are those of the transport processes that control the exchange of solutes between the bentonite porewater and the water in its adjacent components, i.e. the boundary conditions of the processes diffusion and advection.

Table 7-11. Direct dependencies between the process ‘alteration of impurities’ and system component variables and a short note on the handling in SR-PSU.

Variable	Variable influence on process		Process influence on variable	
	Influence present? Yes/No Description	Handling of influence How/If not – Why	Influence present? Yes/No Description	Handling of influence How/If not – Why
Geometry	No, but the pore geometry influences the process indirectly through influencing diffusion.	Pore geometry effects are included in selected diffusion parameters.	Pore geometry is influenced through dissolution and precipitation of accessory minerals.	Resulting variation in porosity is included in the geochemical model.
Temperature	Yes. Temperature affects aqueous and solubility equilibria; possibly also exchange reactions. Also indirectly, via influence on diffusion.	Temperature gradients and effect on aqueous and solubility equilibria is included in the model. Effect on exchange and diffusion is neglected.	No.	–
Hydrological variables	No, but indirectly via water composition.	Saturation phase not modelled explicitly.	No, but indirect effects through water composition.	Neglected.
Mechanical stresses	No, but possibly indirectly through pore geometry and diffusion.	Not considered.	No, but possibly indirectly through influence on porewater composition and swelling.	Neglected.
Material composition	Yes. Composition of bentonite and exchanger are of major importance.	Included in geochemical model.	Yes.	Evolution of composition is calculated by geochemical model.
Water composition	Yes, water composition is of major importance.	Included in geochemical model.	Yes.	Evolution of porewater composition is calculated by geochemical model.
Gas variables	No direct influence, H ₂ , CH ₄ and CO ₂ can influence water composition.	See water composition.	No direct influence. Indirectly through dissolved concentrations.	Included in geochemical model.

Model studies/experimental studies

A number of studies has been performed to characterise the alteration of easily soluble minerals and impurities under realistic conditions (for montmorillonite transformation, see Section 7.4.10). While many studies are conducted under (partly) unsaturated conditions, the conclusions regarding the principal alteration reactions are relevant for saturated systems as well. Similarly, the temperature gradient applied in many large-scale studies are representative for a high level waste repository and are not directly relevant in case of SFR, but the response of the system to the imposed gradients gives valuable insight into the processes.

Several laboratory studies are available on the distribution of soluble ions in the porespace after water uptake in relation to a temperature gradient. For example, Pusch et al. (1993) report on a one-year experiment with hydrothermal treatment of MX-80 clay, which showed that dissolved sulphates and carbonates were transported towards the hot iron surface where they precipitated. It further appears that the enrichment of solutes in clays with a low density is small when the original water content and ambient water pressure are high. Larger-scale field studies, such as the LOT test at Äspö HRL where bentonite material is exposed to large temperature differences during saturation, show that no significant gradients result in terms of silica content while anhydrite precipitations could be found at the high temperature side (Karnland et al. 2009). It was further concluded that almost no cementation did take place in the bentonite material. In summary, the observed mineralogical alteration resulting from the saturation process and temperature gradient, are small and do not significantly affect the physical properties of the bentonite.

Different geochemical models have been used to predict the long-term behaviour of the more soluble materials in bentonite (Wanner et al. 1992, Bruno et al. 1999, Arcos et al. 2000). All these models predict that cation exchange is the dominant process, directly controlling the calcite precipitation-dissolution, and, thus, buffering the pH of the system. Carbonate–calcite equilibrium is identified as the main process buffering the pH (see also Ochs and Talerico 2004). Clay edge sites will act as a buffer only when the calcite is exhausted. This finding is in agreement with experimental data from the EC integrated project NF-PRO (Muurinen and Carlsson 2007). While the actual alteration reactions of minerals and impurities are thus handled very similarly in different model setups, the respective chemical boundary conditions (especially porewater composition) may be predicted somewhat differently by different porewater models as the modelling of porewater chemistry depends to some degree on the underlying assumptions regarding pore characteristics (see Section 7.4.2).

Natural analogues/observations in nature

Observations of certain features (e.g. various types of salt enrichments) in bentonites in arid regions are well documented in the literature and give some insight regarding possible alteration processes during saturation. A bentonite natural analogue study in Spain involving SKB (BARRA project) indicates that exposure to very high salinity does not alter the properties of bentonite (Pérez del Villar et al. 2005). See also Section 7.4.10.

Time perspective

Alteration of impurities is likely to be most important before saturation (which is not considered explicitly in SR-PSU). However, these processes will remain important over the whole assessment period due to the disturbances by alkaline fluids; impurities and accessory minerals will buffer both pH and Eh, provide a source for Ca-ions etc (see also Section 7.4.10). In the modelling studies of Gaucher et al. (2005) and Cronstrand (2007), mineral alteration in the Silo wall is described for the timeframes relevant for SR-PSU.

Handling in the safety assessment SR-PSU

Before saturation: The process is not modelled explicitly.

After saturation: The process is modelled explicitly for different time periods with different gradients. The model outcomes are used to assess the status of relevant safety functions.

Handling of uncertainties in SR-PSU

Uncertainties in mechanistic understanding

Most of the exchange, speciation, dissolution and secondary precipitation reactions are in principle well understood and easily implemented in thermodynamic models. While there are questions regarding details of application to the compacted bentonite system, it appears that different models can describe aqueous and surface reactions as well as diffusion in compacted clay sufficiently well (NEA 2012). For further discussions of the influence of the permanent clay charge on porewater properties and diffusive transport and for an overview of pertinent model concepts, see also Sections 7.4.2 and 7.4.9.

The most relevant uncertainty is related to the dissolution/precipitation behaviour of silica and silicates at high pH. On one hand, the dissolution and precipitation at high pH are not fully understood. On the other hand, it is not clear how any resulting cementation would influence the further evolution of the system. It probably has to be admitted that there is no entirely satisfying approach to solve this issue at present and that not enough reliable experimental data exist that would allow a sound model parameterisation or testing. Uncertainties need to be addressed qualitatively and possibly also by comparing the effects of different model assumptions.

There are also questions regarding the mechanism of pH buffering in the pores. First, it is not clear if sufficient calcite will be present in the bentonite to assume control by the carbonate buffer. Second, various clay–water interaction models available in the literature tend to buffer pH at different values (all within about 2 pH units). This is probably not very relevant in the presence of highly alkaline

solutions. Some uncertainties also exist with regard to the establishment of a redox equilibrium, but it is assumed that residual oxygen is used up after saturation (i.e. that conditions are reducing).

Model simplification uncertainties

There are no actual model simplifications, see handling. The outcomes of the geochemical model are used directly without introducing further simplifications.

Input data and data uncertainties

Most underlying thermodynamic data for aqueous and surface equilibria are well established. The most relevant exceptions to this are thermodynamic data for describing the behaviour of silica and silicates at high pH. Further input data are the composition of the bentonite and contacting solution. The respective uncertainties can be quantified together with the data.

7.4.5 Colloid transport and filtering

Overview/general description

The formation of colloids under conditions relevant to the SFR repository, as well as the nature of potentially important colloids is discussed in the **Waste process report**. Transport and filtering of colloids essentially depends on:

- The stability of the colloidal suspension, which is determined by nature of the colloids and the solution conditions.
- The hydraulic conditions (flow type and rate), which depend on hydraulic gradients and conductivity.
- The filtering efficiency of the water-conducting medium, which depends on geometric properties and on the surface chemistry of the water-conducting features.

Aqueous colloidal suspensions are generally stable (i.e. remain in the dispersed state and do not coagulate or settle out) in dilute, low-ionic strength solutions. Because most colloidal particles have a negative surface charge at neutral or alkaline pH, the cation composition of the solution can be more important than the ionic strength as such. For example, alkaline-earth divalent cations (Ca^{2+} and Mg^{2+}) are much more efficient in destabilising and flocculating colloidal suspensions than monovalent ions. Accordingly, the concentration of suspended colloids in cementitious systems, where dissolved Ca concentrations are relatively high, is controlled at a low level by coagulation (Wieland 2001).

In case of most colloids, the transport through compacted bentonite is negligible, due to the low hydraulic conductivity and the small pore sizes. Under normal conditions no advective flow is expected, and the diffusive transport of most colloids is typically not relevant. However, it has been shown (see model studies/experimental studies below) that organic colloids are able to diffuse through compacted bentonite.

Similar conditions as in bentonite can be expected for the 10:90 bentonite/sand mixture in the top and bottom beds. On the other hand, the sand fill on top of the Silo cannot be expected to represent an efficient filter, due to the large pore sizes and the comparatively limited surface reactivity of quartz (see Section 7.4.3). The following text focuses on the bentonite materials.

Dependencies between processes and barrier variables

Table 7-12 summarises how the process influences and are influenced by all Silo variables. In addition, the handling of each influence in SR-PSU is indicated in the table and more thoroughly discussed in the text below.

Geometry: Transport of most (inorganic) colloids is thought to be negligible in the absence of advective flow. To safely assume diffusive transport regime, the barrier must have a specified minimum density. Pore geometry influences filtration: it can be assumed that a narrower and more tortuous transport path will provide better mechanical filtration and lead to more chemical colloid-surface interactions and attachments.

Table 7-12. Direct dependencies between the process ‘colloid transport and filtering’ and system component variables and a short note on the handling in SR-PSU.

Variable	Variable influence on process		Process influence on variable	
	Influence present? Yes/No Description	Handling of influence How/If not – Why	Influence present? Yes/No Description	Handling of influence How/If not – Why
Geometry	Yes: pore geometry influences the process. Barrier density is more relevant.	Not considered.	No.	–
Temperature	Temperature influences behaviour of colloids, but effect is not clear.	Neglected (temperature range in SFR is narrow).	No.	–
Hydrological variables	Yes. Water flow affects transport of colloids.	Not relevant under saturated conditions.	No (saturated conditions assumed).	–
Mechanical stresses	No, but indirectly through pore geometry, see there.	Not considered.	No.	–
Material composition	No. Indirectly through pore geometry. Layer charge influences diffusion.	Included in specifying minimum density.	No.	–
Water composition	Critical for colloid stability, also influences surface attachment efficiency.	Not considered explicitly.	Yes. The process affects concentration of colloids (but not the bulk composition of aqueous species).	Is discussed in the analyses.
Gas variables	No direct influence, H ₂ , CH ₄ and CO ₂ can influence water composition.	See water composition.	No.	–

Boundary conditions

Boundary conditions for the process occurring in the bentonite barrier and adjacent bentonite/sand beds and sand fill are i) the concentration of colloids at the border of these compartments, and ii) the boundary conditions regarding the transfer of species and suspended particles from these compartments to the host rock, which are the same as for the processes diffusion and advection/dispersion.

Model studies/experimental studies

The diffusion of gold colloids has been studied by Kurosawa et al. (1997) and Holmboe et al. (2010). They found that the gold colloids are effectively filtered out by compacted bentonite as well as by a 50/50 bentonite/sand mixture with a high dry density (1,800 kg/m³). At lower dry densities, the findings are less clear. Holmboe et al. (2010) observed some transport of gold colloids in bentonite with a density of 1,000 kg/m³. Kurosawa et al. (1997) on the other hand observed no colloid transport at a dry density of 1,000 kg/m³ and a sand part of up to 40%. If the sand fraction is increased to 50% there seems to be an indication for colloid breakthrough, but the retention is still high.

In a diffusion experiment with organic colloids through MX-80 bentonite with dry densities of 600 to 1,800 kg/m³ both lingosulphonate (LS) and humic acid (HA) showed similar diffusivity as the negatively charged ions Cl⁻ and I⁻ (Wold 2003). This is somewhat surprising because LS has an average size of 80 nm and HA of ≈ 10 nm and the interlayer distance in saturated bentonite is between ~5 and 10 Å. Possible explanations are the existence of some larger pores in the bentonite, the broad size distribution of the organic colloids and the fact that they are rather flexible macromolecules, or the transformation of organic colloids during the experiment.

Natural analogues/observations in nature

No relevant natural analogue information is available.

Time perspective

The process is important for all assessment periods. The overall timescale of the process is similar to sorption in terms of colloid attachment/detachment and to diffusion in terms of overall transport time.

Handling in the safety assessment SR-PSU

Before saturation: The process is neglected.

After saturation: For most colloids (inorganic forms), the process can in all likelihood be neglected, given the minimum Ca concentration supplied by the cementitious barrier components and/or an intact bentonite barrier. The process may have to be considered for timeframes where modelling indicates a loss of the barrier function with some certainty.

For organic colloids (with some similarity to humic-type substances), diffusive transport through an intact barrier cannot be excluded. Based on the results of Gaucher et al. (2005), no significant concentrations of such colloids are expected for the unperturbed bentonite, however. The binding of radionuclides to such materials could in a first approximation be included in the normal speciation calculations (i.e. treating the organics as normal dissolved ligands). Irreversible binding of radionuclides to organic colloids is considered not likely as long as radionuclide loading is low.

Handling of uncertainties in SR-PSU

Uncertainties in mechanistic understanding

The main uncertainties are related to the nature and behaviour of the colloids. In particular, the diffusion behaviour of organic colloids is not well understood at a mechanistic level. As different colloids can behave quite differently, the level of uncertainty is directly related to the degree to which relevant colloids can be collected and characterised experimentally.

Model simplification uncertainties

There are no actual model simplifications. Given a functioning bentonite barrier, the process is neglected for most colloids. Organic colloids can approximately be treated like dissolved ligands, as long as radionuclide loading is low.

In case of a loss of barrier functions, conservative bounding calculations of radionuclide transport can be used.

Input data and data uncertainties

There are no specific input data. If radionuclide binding by organic colloids needs to be modeled, different binding models with corresponding thermodynamic data are available. The corresponding uncertainties are considered to be negligible in comparison to the uncertainties of the diffusive transport process.

7.4.6 Dissolution/Precipitation

Overview/general description

In terms of the involved materials, these processes are only relevant for the bentonite in the barrier and the top and bottom beds. The quartz in the sand fill can be considered inert in this respect. On the other hand, precipitation from oversaturated aqueous solution can occur in any part. In case of the bentonite barrier, this process is contained in the processes 'alteration of impurities' (Section 7.4.4) for the accessory minerals and impurities and 'montmorillonite transformation' (Section 7.4.10) for the montmorillonite.

Dependencies between processes and barrier variables.

Table 7-13 summarises how the process influences and are influenced by all Silo variables. In addition, the handling of each influence in SR-PSU is indicated in the table.

Table 7-13. Direct dependencies between the process ‘dissolution/precipitation’ and system component variables and a short note on the handling in SR-PSU.

Variable	Variable influence on process		Process influence on variable	
	Influence present? Yes/No Description	Handling of influence How/If not – Why	Influence present? Yes/No Description	Handling of influence How/If not – Why
Geometry	No, but indirectly through influencing diffusion of reactants and water composition.	Pore geometry effects are included in selected relevant diffusion parameters, see Section 7.4.2.	Pore geometry is influenced through dissolution and precipitation of accessory minerals.	Resulting variation in porosity is included in the geochemical model.
Temperature	Yes. Temperature effects aqueous and solubility equilibria; possibly also exchange reactions. Kinetics of mineral alteration and diffusion is also influenced.	Temperature gradients and effect on aqueous and solubility equilibria is included in the model. Effect on kinetics, exchange and diffusion is neglected.	No.	–
Hydrological variables	Fast water flows at border of bentonite barrier can increase reaction rates.	Saturation phase not modelled explicitly.	No, but indirectly through geometry and water composition.	Neglected.
Mechanical stresses	No, but possibly indirectly through pore geometry and diffusion of reactants, influencing water composition.	Not considered.	No, but possibly indirectly through influence on pore-water composition and swelling.	Neglected.
Material composition	Yes. Composition of bentonite and exchanger are of major importance.	Included in geochemical model.	Yes.	Evolution of composition is calculated by geochemical model.
Water composition	Yes, water composition is of major importance.	Included in geochemical model.	Yes.	Evolution of porewater composition is calculated by geochemical model.
Gas variables	No direct influence. H ₂ , CH ₄ and CO ₂ can influence water composition.	See water composition.	No direct influence. Indirectly through dissolved concentrations.	Included in geochemical model.

Boundary conditions

Initial boundary conditions are the bentonite and water composition. The relevant boundary conditions in order to treat the process quantitatively are those of the transport processes that control the exchange of solutes between the buffer pore water and the water in its adjacent components, i.e. the boundary conditions of the processes diffusion and advection.

Model studies/experimental studies

Model and experimental studies for this process are given in the corresponding sections in the processes ‘alteration of impurities’ and ‘montmorillonite transformation’ (Sections 7.4.4 and 7.4.10).

Natural analogues/observations in nature

See Sections 7.4.4 and 7.4.10.

Time perspective

See Sections 7.4.4 and 7.4.10.

Handling in the safety assessment SR-PSU

Before saturation: The process is not modelled explicitly.

After saturation: The process is modelled explicitly for different time periods with different gradients. The model outcomes are used to assess the status of the relevant safety functions. Both the maintenance of a sufficiently high pH as well as the presence of sorbing surfaces are feeding into the chemical safety function ‘good sorption’.

Handling of uncertainties in SR-PSU

See Sections 7.4.4 and 7.4.10.

7.4.7 Concrete degradation

Overview/general description

Concrete degradation has been described in detail for BMA (Section 5.4.6). The Silo concrete barrier is reinforced, in common with 1BMA, but the Silo has an additional bentonite barrier surrounding this. This section therefore focuses on the impact of the Silo’s bentonite barrier on concrete degradation processes.

The presence of the bentonite barrier will prevent fast advective transport and reduce the diffusive transport, and will thereby reduce the rate of concrete leaching and degradation. The precipitation of secondary minerals at the concrete – bentonite interface may locally clog the pore volume and lower the effective diffusivity further, slowing degradation processes further. As described in Section 7.4.10, the dissolution of montmorillonite in highly alkaline solutions is expected to liberate Al, Si, Mg and Na ions (Gaucher et al. 2005). The diffusion of these ions into the adjacent concrete barrier may influence the range of secondary minerals that precipitate. Additionally, ion exchange processes in the bentonite will also affect diffusive gradients at the concrete – bentonite interface. Additionally, the model of Gaucher et al. (2005) showed that the initial concentrations of SO_4^{2-} and Mg^{2+} were higher in the porewater of the bentonite than the concrete. The expanding SO_4^{2-} mineral ettringite was seen to precipitate in the model at the bentonite – concrete wall interface at 500 years, and at increasing depth in the concrete wall over time. Therefore, initially elevated SO_4^{2-} concentrations in the bentonite porewater may contribute to ettringite formation in the concrete barrier.

The bentonite barrier may also influence the performance of the concrete barrier indirectly by filling fractures that are present or form during the repository lifetime. According to model presented in Birgersson et al. (2009) the intrusion of bentonite into fractures is restricted to a maximum depth of about 40 times the fracture aperture which is judged negligible when fractures are small. Montmorillonite colloids are not likely to be stable (Section 7.4.12) and so will not affect the concrete barriers significantly.

Dependencies between processes and barrier variables

Table 5-12 shows how concrete degradation processes influence, and are influenced by, the defined concrete barrier variables for 1BMA and is also relevant for concrete degradation in the Silo.

Boundary conditions

There are no particular boundary conditions to discuss for these processes. The relevant boundary conditions in order to treat the processes quantitatively are those of the transport processes that control the solutes transport between the cement matrix, the waste, the concrete packaging and the bentonite as adjacent system components, i.e. the boundary conditions of the processes diffusion (see Section 5.4.2) and advection (see Section 5.4.1). The boundaries of this analysis are the barriers themselves with exchange of mass and heat from the waste/waste package and the surrounding geosphere considered. Cooling will occur as the repository resaturates with groundwater, leading to thermal contraction of the concrete barriers and possibly affecting fracture widths. Other major periods of heat transfer are likely to be the long term transitions between temperate and glaciation periods. Due to its swelling pressure, the bentonite also exerts a mechanical contact pressure on the outside of the concrete wall.

Model studies/experimental studies

As discussed in Section 7.4.10, montmorillonite transformation in the Silo bentonite barrier is primarily related to the presence of highly alkaline conditions, and has been included in two scenario-specific geochemical models of the Silo (Gaucher et al. 2005, Cronstrand et al. 2007). The dissolution kinetics of clays, zeolites and cements were not included in the calculations due to a shortage of experimental data (Gaucher et al. 2005), thus dissolution was calculated at each time step according to the local equilibrium approach. These studies suggest that the concrete will not have degraded fully after 100,000 years.

Various modelling studies have investigated mineralogical changes at concrete – argillite interfaces to support the French disposal programme. These can be compared with data from a 15 year in situ experiment examining changes in the porosity and mineralogy at a concrete – argillite interface (Gaboreau et al. 2011) that has also been modeled (Techer et al. 2012). The experimental data showed an increase in the porosity of the concrete that corresponded to the dissolution of portlandite in the first centimetre. The observations were consistent with a gradual decalcification through portlandite dissolution and then leaching of Ca from CSH phases. This was accompanied by a decrease in the porosity of the argillite at the interface, which was suggested to be due to the presence of CSH and CASH phases. These have a low crystallinity and are difficult to detect, thus their presence was not confirmed in the study. The experiments also showed that the clay was largely sealed. There was general consistency with previous modelling studies (Pfungsten 2002, Trotignon et al. 2006, De Windt et al. 2008, Marty et al. 2009) with respect to portlandite dissolution and clogging of argillite. However, different phases were predicted to precipitate in the clay when kinetics were not included in the models (e.g. in Pfungsten 2002, Trotignon et al. 2006). Marty et al. (2009) specifically investigated the effect of reaction kinetics and mesh refinement on the numerical modelling of concrete-clay interactions, and showed that inclusion of kinetic effects delayed the predicted clogging of the porosity. De Windt et al. (2008) showed that the influence of kinetics on the results was more important in the clay than in the concrete. Processes that take place at the clay – concrete interface will clearly affect the overall barrier performance.

Natural analogues/observations in nature

Natural analogue studies have been discussed in Section 5.4.6 for concrete degradation and Section 7.4.10 for montmorillonite alteration.

Time perspective

Concrete in the Silo will degrade following the sequence, but not the time scale, shown for BMA in Section 5.4.6. The presence of the clay barrier is expected to reduce the rate of concrete degradation. Therefore the Silo concrete barrier is not expected to be fully degraded by 100,000 years, unless an external event affects the repository performance (Gaucher et al. 2005, Cronstrand 2007, 2014, Höglund 2014).

Handling in the safety assessment SR-PSU

The modelling will be equivalent to that for 1BMA (see Section 5.4.6), but the geometry and design of the Silo will be represented, including the bentonite barrier.

Handling of uncertainties in SR-PSU

The uncertainties are a combination of those associated with concrete degradation (Section 5.4.6) and montmorillonite alteration (Section 7.4.10).

Uncertainties in mechanistic understanding

See Section 5.4.6 and Section 7.4.10.

Model simplification uncertainties

See Section 5.4.6. and Section 7.4.10.

Input data and data uncertainties

See Section 5.4.6 and Section 7.4.10.

Adequacy of references supporting the handling in SR-PSU.

The references are judged to be adequate and sufficient to support the handling in SR-PSU. All supporting references are either peer-reviewed articles or documents which have undergone factual review.

7.4.8 Aqueous speciation and reactions

Overview/general description

This process is relevant for all barrier compartments. It addresses all aqueous chemical equilibria in pore solutions, including redox reactions, of main elements (C, Si, Ca...), radionuclides (see Section 7.5.1) and dissolved (reactive) organic substances. Usually aqueous speciation reactions are fast and can therefore be described by equilibrium thermodynamics and mass-action laws.

Aqueous speciation is relevant in the porewater (comprising about 40 vol% at saturation) of the bentonite barrier. The composition of this water will be determined by the composition of the porewater present at closure as well as of the groundwater at the site, by reactions with the bentonite and container material and by the impurities in the bentonite. The related surface–solution and solubility reactions are addressed in several other sections, especially Sections 7.4.3, 7.4.4 and 7.4.10.

Dependencies between processes and barrier variables

Table 7-14 summarises how the process influences and are influenced by all Silo variables. In addition, the handling of each influence in SR-PSU is indicated in the table and more thoroughly discussed in the text below.

Geometry: The ratio of solids to porewater (given by the bentonite composition and density) largely determines the outcome of the speciation process. The process itself is independent of composition. Similarly, pore geometry is influenced by reactions of accessory minerals which involve aqueous speciation. While the present process facilitates these other processes, it does not affect geometry in itself.

Table 7-14. Direct dependencies between the process ‘aqueous speciation and reactions’ and system component variables and a short note on the handling in SR-PSU.

Variable	Variable influence on process		Process influence on variable	
	Influence present? Yes/No Description	Handling of influence How/If not – Why	Influence present? Yes/No Description	Handling of influence How/If not – Why
Geometry	No.	–	No.	–
Temperature	Yes. Temperature effects aqueous speciation.	Thermodynamic database for aqueous equilibria contains data for temperature dependencies of reactions.	No.	–
Hydrological variables	No.	–	No.	–
Mechanical stresses	No.	–	No.	–
Material composition	Determines the reactants available to aqueous speciation.	Included in geochemical model.	Yes, through solubility and exchange equilibria.	Evolution of composition is calculated by geochemical model.
Water composition	Groundwater supplies reactants available to aqueous speciation.	Included in geochemical model.	Yes Porewater composition is influenced by speciation.	Evolution of porewater composition is calculated by geochemical model.
Gas variables	No direct influence. H ₂ , CH ₄ and CO ₂ can influence water composition.	See water composition.	No direct influence. Indirectly through dissolved concentrations.	Included in geochemical model.

Hydrological variables: Similar to the above, hydrological variables may influence porewater composition, but not the speciation process itself.

Boundary conditions

The relevant boundary conditions in order to treat the process quantitatively are the boundary conditions of the processes that influence temperature and porewater composition; i.e. those of the process heat transport and of the transport processes (diffusion and advection), sorption, alteration of impurities and dissolution/precipitation.

Model studies/experimental studies

Aqueous chemical equilibria are an integral part of any thermodynamic porewater or sorption model (see Sections 7.4.3, 7.4.4). The relevant aqueous species and stability constants are well established and part of many standard speciations codes (e.g. Parkhurst and Appelo 1999). Both species and stability constants are typically based on a large number of experimental data from simplified systems.

On the other hand, the determination of the composition of porewater in compacted bentonite is almost impossible. Only small amounts of porewater can be squeezed out of the bentonite and the squeezed porewater is likely not representative for the porewater in situ. The total concentration of the non-sorbing and soluble elements can be estimated by total dispersion of bentonite in water. The speciation of main and trace porewater constituents has to be calculated.

Natural analogues/observations in nature

See Section 5.5.1.

Time perspective

Speciation is relevant for all assessment periods. It can be considered fast in comparison to transport processes; i.e. local equilibrium can be assumed.

Handling in the safety assessment SR-PSU

Before saturation: The process is not modelled explicitly.

After saturation: The process is an integral part of the scenario specific modelling of the bentonite chemical evolution. The establishment of reducing conditions is linked to the chemical safety function 'good sorption'.

Speciation of radionuclides is also modelled to form the basis for the definition of sorption and diffusion coefficients. If relevant, it could be used to estimate solubility limits, but these are not considered in the SR-PSU safety assessment.

Handling of uncertainties in SR-PSU

Uncertainties in mechanistic understanding

The process as such is well established. Uncertainties relate mainly to the handling of speciation in the narrow bentonite pores, i.e. to uncertainties regarding the porewater characteristics and activity (see also Sections 7.4.2 and 7.4.9) and at a very low water/solid ratio. Uncertainties regarding further assumptions made for modelling bentonite evolution are also relevant.

In some cases, there are also uncertainties regarding the nature of reactants and/or the completeness of the thermodynamic database (TDB). This concerns e.g. organics, some redox equilibria, solids and aqueous species at very high pH.

Model simplification uncertainties

There are no actual model simplifications; the process is directly included in the geochemical model. For consequence calculations, the various aqueous–solid–surface equilibria involving radionuclides are expressed in a simplified way (see Section 7.5.1).

Input data and data uncertainties

Input data are the compositional data of solids and solutions involved in the process (bentonite, groundwater) and the thermodynamic equilibrium constants. The associated numerical uncertainties are relatively well defined and presumably not important in comparison to the conceptual uncertainties of modelling the system evolution. Uncertainties in groundwater composition can be handled by considering scenario-specific bounding compositions.

7.4.9 Osmosis

Overview/general description

Osmosis normally refers to a process taking place in a system of solutions divided by a semi-permeable membrane, where some, but not all, ions or molecules can pass between the two system parts (in the classical concept, the solvent can pass through the membrane, but solutes cannot). The resulting differences of ion concentration between the two parts, for both the ions with full and restricted mobility, create also a difference in water activity between the two sides. This results in an osmotic pressure. An ion distribution where the movement of ions or molecules may be restricted due to e.g. their large size is a typical representation of a Donnan equilibrium system (Donnan 1911). This process is only relevant for the bentonite barrier and the sand/bentonite beds. In the latter, the sand can be viewed as a minor inert component.

The analogous situation in a bentonite barrier has been described by Karnland et al. (2005); their argumentation is followed here as well. Basically, bentonite acts as a semi-permeable membrane dividing internal (porewater) and external (ground- or cement water) solution. The limited permeability of the bentonite stems from mechanical restrictions as well as from the permanent negative clay charge. In this system, neutral water molecules and electrolyte cations can move more or less freely, while the mobility of anions is restricted:

- The anions of the electrolyte solution cannot move freely into the narrow bentonite pores due to the negative charge of the clay (anion exclusion, see also Sections 7.4.2 and 7.4.4);
- the clay platelets themselves can be seen as anions which are immobile due to their size.

Because the solution anions cannot freely enter the bentonite porewater, an external solution placed in contact with the bentonite will give rise to an osmotic pressure which counteracts (reduces) the swelling pressure of the clay (which arises from the electrostatic repulsion of the clay platelets). The reduction of the swelling pressure is dependent on the concentration of ions entering the bentonite. This concentration can be calculated using a Donnan-equilibrium model (Karnland et al. 2005), see below. They further show that ion concentrations modelled in this way allow to closely estimate experimental swelling pressure data (see model studies/experimental studies).

Dependencies between processes and barrier variables

Table 7-15 summarises how the process influences and are influenced by all Silo variables. In addition, the handling of each influence in SR-PSU is indicated in the table and more thoroughly discussed in the text below.

Geometry: The process of osmosis as well as the development of swelling pressure in compacted (confined) bentonite is caused by the permanent negative charge of the clay platelets:

- The electrostatic repulsion between opposing clay platelets gives rise to swelling;
- the electrical double layer forming above the charged clay surface causes the anion deficit in the pores.

It follows that the distance between opposing clay platelets (on average, the pore width) is critical for the process and its effect on swelling. This distance is mainly determined by the bentonite density. Taking a slightly different point of view, the bentonite density determines the concentration of clay negative charge per unit volume (i.e. the concentration of immobile clay ‘anions’). This concentration feeds directly into Donnan-type models.

Water composition: The external groundwater composition influences the porewater composition and further variables through osmosis. The actual process itself is independent of composition, but its extent depends on concentration differences between external and pore solution.

Table 7-15. Direct dependencies between the process osmosis and system component variables and a short note on the handling in SR-PSU.

Variable	Variable influence on process		Process influence on variable	
	Influence present? Yes/No Description	Handling of influence How/If not – Why	Influence present? Yes/No Description	Handling of influence How/If not – Why
Geometry	Pore geometry (width) influences electrostatic potential.	Included in model.	No, but indirect influence on pore geometry via water composition and swelling.	Effect on swelling is calculated by the model. Possible influence of swelling on geometry is neglected.
Temperature	Yes. Temperature effects all chemical equilibria.	Neglected, only small temperature range expected.	No.	–
Hydrological variables	No, but possibly indirectly through water composition.	Not considered.	No, but indirect influence through water composition and swelling pressure.	The effect of groundwater composition on swelling and hydraulic conductivity is evaluated.
Mechanical stresses	No, but indirectly via geometry.	Not considered.	No, but indirect influence through water composition and swelling pressure.	See hydrological variables.
Material composition	Yes, through smectite content and charge.	Included as input data to model.	Process influences counterion composition.	Considered in modelling.
Water composition	Yes. Groundwater influences porewater composition and therefore osmosis.	Included in geochemical model.	Yes. Porewater composition is determined by process.	Porewater composition is calculated by model.
Gas variables	No direct influence, H ₂ , CH ₄ and CO ₂ can influence water composition.	See water composition.	No direct influence. Indirectly through dissolved concentrations.	Neglected.

Boundary conditions

The relevant boundary conditions are those that influence porewater and solid composition; i.e. those of the transport processes (diffusion and advection), sorption, alteration of impurities and dissolution/precipitation.

Model studies/experimental studies

Karland (1997) reported preliminary results concerning the influence of groundwater salinity on swelling pressure. Subsequently, a comprehensive model as well as experimental data for the conversion of MX-80 bentonite to a pure sodium state has been developed (Karland et al. 2005). Karland et al. (2006) conducted further studies with the two reference bentonites MX-80 and Deponit-CaN before and after conversion to pure sodium and calcium state.

Natural analogues/observations in nature

No analogue observations are available, to our knowledge. Neuzil (2000) discussed the generation of fluid pressures in geological environments by osmosis.

Time perspective

The process is relevant for the entire assessment period. The process itself (i.e. the adjustment of swelling pressure) is fast in comparison to changes in conditions.

Handling in the safety assessment SR-PSU

Before saturation: The process is neglected.

After saturation: The effect of osmosis on swelling and hydraulic conductivity is evaluated by direct use of empirical data obtained as a function of salinity, where available. These data can be explained and supplemented by model calculations.

Handling of uncertainties in SR-PSU

Uncertainties in mechanistic understanding

Empirically, the process as such is well characterised. Similarly, the theory of Donnan equilibrium is established and well tested. On the other hand, there are still fundamental uncertainties regarding the characteristics of narrow bentonite pores. For example, the Donnan-model assumes a homogeneous medium, while other approaches assume the presence of different types of porewater (see also Sections 7.4.2, 7.4.4). However, it has been shown that many macroscopic observations can be explained about equally well by the different model concepts (within the given uncertainties). For the process of osmosis, the Donnan-model approach is accepted as the most suitable on the basis of the presently available information.

Model simplification uncertainties

The process itself is not represented for safety analyses. The process results, namely swelling and hydraulic conductivity, are evaluated mainly on the basis of empirical data. For the representation of porewater composition and ion diffusion as a function of density, see Sections 7.4.4 and 7.4.2.

Input data and data uncertainties

Input data are the compositional data of solids and solutions involved in the process (bentonite, groundwater). The largest uncertainties are probably associated with compositional data that have to be defined by modelling the system evolution (Section 7.4.4). Uncertainties in groundwater composition can be handled by considering scenario-specific bounding compositions.

7.4.10 Montmorillonite transformation

Overview/general description

Montmorillonite is present in the bentonite barrier and the sand/bentonite top and bottom beds. Under typical groundwater conditions, there are a range of possible montmorillonite transformations that could lead to minerals with the same basic atomic structure as montmorillonite but decreased ability to swell. In the Silo of SFR, the bentonite is placed between concrete components, and relevant transformations of montmorillonite (and any accessory silicate minerals present) will be driven by contact with highly alkaline solutions.

While it is clear that montmorillonite transformation is relevant in the presence of highly alkaline solutions, there is great uncertainty regarding reaction pathways and products as well as regarding extent or kinetics of the transformation reaction. To a significant part, this uncertainty results from the kinetic control of the process.

Cement–clay interactions were studied in the EU-project ECOCLAY-II (EC 2005). Based on the outcome of this project, it seems that a simplified but reasonably realistic view of the transformation process would consider that the dissolution of montmorillonite in highly alkaline solutions would liberate Al, Si, Mg and Na ions. Subsequently, these elements can re-precipitate in the form of a range of silicates and aluminosilicates (see the discussion of Gaucher et al. (2005) in the section on model studies/experimental studies).

Additional dissolved elements are supplied by the alkaline solution itself. Depending on the degradation state of the concrete, solutions leaching from the cement-based Silo components supply mainly Na/K or Ca ions.

Taking into account the ECOCLAY-II results, Gaucher et al. (2005) summarises the reactions that will take place when montmorillonite is exposed to highly alkaline solutions (with a low potassium content) as follows (see SKB 2008b):

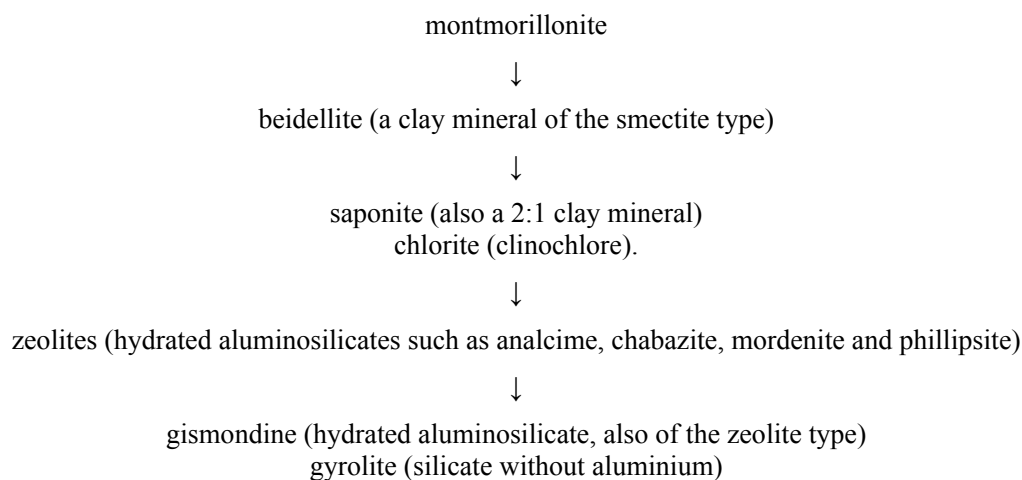

Considering the mentioned uncertainties, the above should be viewed as one out of several possible sequences of reactions. If the alkaline fluid is rich in potassium, illite can be formed, possibly followed by formation of phillipsite.

In comparison to the originally present montmorillonite, the secondary phases according to the above summary have a high molar volume, which presumably would tend to reduce or block the available porosity. On the other hand, these minerals do not possess the ability to swell, which would lead to a drop in, or complete loss of, swelling pressure. Depending to which degree the discussed transformations take place, a loss of barrier functions cannot be excluded. The modelling by Gaucher et al. (2005) indicates a nearly complete disappearance of montmorillonite in the long term, while other studies (Cronstrand 2007, Fernández et al. 2009a) indicate a significantly smaller effect (see model studies/experimental studies).

Dependencies between processes and barrier variables

Table 7-16 summarises how the process influences and are influenced by all Silo variables. In addition, the handling of each influence in SR-PSU is indicated in the table and more thoroughly discussed in the text below.

Boundary conditions

The relevant boundary conditions are the temperature and the boundary conditions that influence porewater and solid composition; i.e. those of the transport processes diffusion and advection.

Model studies/experimental studies

As pointed out above, montmorillonite transformation in the Silo bentonite barrier is primarily related to the presence of highly alkaline solutions in the adjacent cementitious Silo wall and lining. A number of studies have been carried out to understand the physicochemical behavior of argillaceous materials due to the effects of a hyperalkaline plume released by cement that is used in the construction of radioactive waste repositories, such as the ECOCLAY II project (EC2005), see also references therein.

The experimental and modelling results accumulated to date allow to build databases of both thermodynamic data as well as kinetic rate constants. Starting from such data, Fernández et al. (2009a) calibrated a geochemical model against experimental data from a column experiment with cement mortar and compacted bentonite and used it subsequently to describe the long-term behavior of the cement-bentonite interface. Their results indicate the formation of various secondary minerals (hydroxides, zeolites, clay minerals) but suggest also that the alteration produced even on long timescales (10^5 years) is not very significant under the given boundary conditions. Significant

Table 7-16. Direct dependencies between the process ‘montmorillonite transformation’ and system component variables and a short note on the handling in SR-PSU.

Variable	Variable influence on process		Process influence on variable	
	Influence present? Yes/No Description	Handling of influence How/If not – Why	Influence present? Yes/No Description	Handling of influence How/If not – Why
Geometry	Affected montmorillonite mass depends on thickness of barrier. Pore geometry has indirect influence through diffusion.	Barrier thickness and diffusion included in various models.	Pore geometry influenced by definition. Indirect influence on barrier geometry possible for very long time frames.	Influence of process on all safety functions is evaluated based on model predictions.
Temperature	Yes. Temperature effects all chemical equilibria.	Neglected, only small temperature range expected.	No.	–
Hydrological variables	No, but indirectly through water composition.	–	No, but indirect via changes in material composition.	Loss of hydraulic barrier function considered (depending on scenario).
Mechanical stresses	No, but indirectly via geometry.	Not considered.	No, but indirectly through geometry.	Loss of barrier functions considered (depending on scenario).
Material composition	Yes, by definition.	Included as input data to model.	Yes, by definition.	Result of modelling.
Water composition	Yes, by definition.	Included as input data to model.	Yes, by definition.	Porewater composition is calculated by model.
Gas variables	No direct influence, H ₂ , CH ₄ and CO ₂ can influence water composition.	See water composition.	No direct influence. Indirectly through dissolved concentrations.	Neglected.

mineralogical changes in the bentonite are in the order of a few centimetres from the concrete interface, thus leaving a large part of the bentonite unaffected and, hence, maintaining its barrier function. Based on the results from a 1-year study of the interaction of different synthetic alkaline fluids with compacted bentonite (Mg-form), Fernández et al. (2009b) conclude that the high-pH front moves much slower than the alteration front due to the pH-buffering effect of mineral reactions. They also observed that the newly formed minerals tend to shield the montmorillonite from further alteration.

Gaucher et al. (2005) and Cronstrand et al. (2007) developed site- and scenario-specific geochemical models to investigate the evolution of the multi-barrier system in the SFR Silo. Both models follow similar approaches (1-dimensional reactive diffusive transport), but differ in a number of details, such as the development of porewater composition and porosity. They also considered different boundary conditions in terms of diffusion parameters and external influences. Despite these differences, these modelling studies allow to draw the following conclusions:

- A large portion of the bentonite barrier will be preserved almost intact over a period of up to 20,000 years.
- For the period of up to 100,000 years, the results are more divergent. In the extreme modelling cases considering extensive freeze/thaw cycles and/or high pore diffusion coefficients, the results indicate a strong to complete alteration of the bentonite barrier (and a significant alteration of the Silo wall). However, none of these scenarios are viewed as very realistic.

Natural analogues/observations in nature

Smellie (1998) summarise results of the Maqarin (Jordan) natural analogue site on the influence of hyperalkaline groundwater on rocks of different compositions. The respective processes are similar to those that might occur within the alkali disturbed zone of cementitious repositories in different host rocks. One objective of this analogue study was to investigate whether the matrix of the clay (biomicrite) host rock has been affected by the hyperalkaline groundwaters, and whether this host rock had undergone relevant mineralogical and geochemical changes around water-conducting fractures.

While i) pre-existing lithological variations in the host rocks impose limitations with regard to assessing the geochemical alterations and ii) the results are influenced by the presence of micro-fractures around the major fractures (generally extending several tens of millimetres into the host rock) it is concluded that the geochemical composition of the host rock is not distinguishable from the variation in the lithological background at a distance of > 40 mm away from the major fractures. This is a strong indication that no alteration occurred at greater depth.

Time perspective

In principle, the process is relevant for the whole assessment period. The model calculations by Gaucher et al. (2005) and Cronstrand (2007) indicate, however, that significant effects are not to be expected for the periods up to $\approx 20,000$ years.

The process of montmorillonite transformation under highly alkaline conditions is kinetically controlled, but experimental timeframes of less than 0.5–1 year are sufficient to observe complete transformation, see e.g. Fernández et al. (2009b). The very slow progression of alteration fronts is due to other effects, such as changes in porosity and montmorillonite accessibility resulting from the formation of alteration products with a higher molar volume.

Handling in the safety assessment SR-PSU

Before saturation: The process is neglected.

After saturation: The process is modelled for different time periods on the basis of different assumptions (compositions/gradients, reaction rates etc). The modelling results are used to assess the status of barrier safety functions.

Handling of uncertainties in SR-PSU

Uncertainties in mechanistic understanding

As indicated in the overview section, there are considerable and fundamental uncertainties regarding the process. These can be divided into two types:

- Some basic uncertainties relate to the actual process of montmorillonite transformation itself. The mineralogical reaction products, the kinetic rates and the overall extent of this process are influenced by a large range of solution and solid composition variables as well as temperature. The respective influences are not fully understood to date. Moreover, there is no consensus regarding the various interrelations (such as pH buffering by dissolution, effect of liberated ions etc).
- The progress of the transformation process in a dynamic system is dependent on further variables, such as the formation of cementation crusts that can protect mineral surfaces, changes in porosity and hydraulic conductivity etc. There are significant uncertainties regarding the various feedbacks between the transformation process and these subsequent processes, and how these depend on the chemical conditions.

Model simplification uncertainties

There are no overall model simplifications; the process is modeled in detail, and for different sets of conditions. The outcomes of the modelling are used to assess the status of barrier functions.

Input data and data uncertainties

Input data are the compositional data of solids and solutions involved in the process, as well as a large range of thermodynamic data and expressions for reaction rates. Uncertainties in compositional data can be handled by considering bounding compositions. Handling of uncertainties in thermodynamic data and rates is not straightforward: numerical uncertainties for a given reaction constant can be defined, but it is not clear how the uncertainty due to e.g. a missing mineral phase can be quantified.

7.4.11 Iron–bentonite interaction

Overview/general description

Several parts of the repository contain large amounts of metallic iron, which is not thermodynamically stable under repository conditions. The anaerobic corrosion expected to take place after closure of the repository will produce Fe(II), which can then react with the available barrier materials as well as dissolved constituents.

Similar to the interaction of bentonite with alkaline fluids, Fe–bentonite interaction is a complex process that is not yet well understood. In principle, Fe(II) may influence barrier performance through different mechanisms (Wersin et al. 2008):

- Fe(II) will sorb to the clay surfaces, mainly to the clay edge. This will influence the sorption of further dissolved species, including radionuclides, to the clay. It is presently not clear whether this would result in a purely competitive effect, or whether the formation of new phases involving the sorbed Fe(II) plus further sorbed constituents, such as silica, would actually increase the sorption capacity of the clay.
- The sorbed Fe(II) will presumably lead to an alteration of the clay minerals. Present evidence suggests some type of Fe-rich clay mineral as alteration product, such as a saponite or chlorite, or possibly a 1:1 clay. While saponite belongs to the smectite group and show therefore some similarity to montmorillonite, chlorite and 1:1 clay minerals have no swelling capability. This would cause a significant deterioration of barrier functions.
- It is further not clear whether/how the sorbed Fe(II) would interact with the structural Fe(III) in montmorillonite.
- Depending on Fe(II) concentrations and conditions, the precipitation of Fe-phases in the bentonite could also affect its properties.

An important consideration in case of the Silo is the placement of a substantial cementitious barrier between the bentonite and the waste. Therefore, corroding iron will be primarily in contact with cement, and the effect on bentonite will depend on the transfer of dissolved Fe(II) through the cement mass. It can be expected that this transfer will be small enough to render the process not significant in comparison to the interaction of bentonite with alkaline fluids.

Dependencies between processes and barrier variables

Table 7-17 summarises how the process influences and are influenced by all Silo variables. In addition, the handling of each influence in SR-PSU is indicated in the table and more thoroughly discussed in the text below.

Boundary conditions

The relevant boundary conditions are the processes influencing corrosion, the temperature and in particular the boundary conditions that influence the transport of Fe(II) through the concrete barrier.

Model studies/experimental studies

Iron–bentonite interaction has been studied for situations where the two materials are in direct contact. Experimental and model results are briefly discussed below. However, as pointed out in the overview section above, the process is expected to be of little relevance due to the placement of the concrete barrier between bentonite and waste.

The iron–bentonite interaction in a KBS-3H repository was assessed by mass balance estimates and a reactive transport modelling (Wersin et al. 2008). The mass balance results indicate that a maximum of 10–30% of the montmorillonite could be converted to a non-swelling Fe(II)-rich clay. Based on the results of the reactive transport model it can be concluded that the extent of the zone transformed to non-swelling material is likely to remain spatially limited (a few centimetres) even for long time period.

Table 7-17. Direct dependencies between the process ‘iron–bentonite interaction’ and system component variables.

Variable	Variable influence on process		Process influence on variable	
	Influence present? Yes/No Description	Handling of influence How/If not – Why	Influence present? Yes/No Description	Handling of influence How/If not – Why
Geometry	Affected mass depends on thickness of barrier. Pore geometry has indirect influence through diffusion.	Process neglected in comparison to effect by alkaline fluids.	Pore geometry influenced by definition. Influence on barrier geometry possible for very long time frames.	Neglected in comparison to effect by alkaline fluids.
Temperature	Yes. Temperature effects all chemical equilibria.	Neglected, see above.	No.	–
Hydrological variables	No, but indirectly through water composition.	Neglected, see above.	No, but indirectly through changes in material composition.	Neglected, see above.
Mechanical stresses	No, but indirectly via geometry.	Not considered.	No, but indirectly via change in material composition and geometry.	Neglected, see above.
Material composition	By definition.	Neglected, see above.	Yes, by definition.	Neglected, see above.
Water composition	By definition.	Neglected, see above.	Yes, by definition.	Neglected, see above.
Gas variables	No direct influence, H ₂ , CH ₄ and CO ₂ can influence water composition.	Neglected, see above.	No.	–

Natural analogues/observations in nature

Possible analogues could be naturally occurring native iron (meteoritic or non-meteoritic) or perhaps old archaeological artifacts in contact with bentonites or other clays. However because of the rare nature and the uncertain history of the objects they are probably of limited value. Other natural analogues could be soils in anaerobic environments in rice fields where Fe-rich chlorites or 1:1 minerals have been identified (Favre et al. 2002). However, for SFR these are not very valuable, since the process is expected to be irrelevant.

Time perspective

Not applicable, since the process is expected to be not relevant.

Handling in the safety assessment SR-PSU

Before saturation: The process is neglected.

After saturation: It is assumed that the contribution of Fe corrosion products to the alteration of the bentonite barrier can be neglected in comparison to the effect of alkaline fluids, mainly because of the limited transport of Fe(II) through the concrete silo. This is based on the good sorption properties of hydrated cement even at high degrees of degradation (see Section 5.4.3) as well as on the strong sorption tendency of Fe(II). Similarly, corrosion of iron will not be influenced by the bentonite; the conditions at metal surfaces will be dominated by hydrated cement.

Handling of uncertainties in SR-PSU

Substantial gaps in understanding the process are acknowledged, the most important of these are mentioned above in the overview section. However, these uncertainties are not relevant, as the process is neglected.

7.4.12 Montmorillonite colloid release

Overview/general description

One of the most important features of bentonite with regard to its use as a barrier for repositories of radioactive waste is its swelling capability, which is responsible for the low hydraulic conductivity and self-healing properties. In a confined space, such as the Silo wall fill, the uptake of water and resulting swelling of the bentonite is counteracted by the walls, and a swelling pressure is developed in the bentonite.

Openings in the confining walls (e.g. intersecting fractures) mean a local loss of swelling restriction, and localised swelling may continue into such openings until a thermodynamic equilibrium is reached. Such free swelling may lead to separation of individual clay platelets (or of small stacks of platelets), resulting in a dispersion of the clay. Depending on flow conditions, the dispersed portions of the clay could be transported away with the groundwater as individual colloidal particles.

The dispersion behaviour of montmorillonite is strongly dependent on the valence and concentration of the ions in the porespace. Dispersion (formation of a clay sol) from aggregated clay (clay gel) is mainly relevant in the presence of dilute groundwaters and especially at low concentrations of divalent groundwater cations (Ca, Mg). For the parameter space of simple mono- and divalent cations (with a monovalent counter-anion), Birgersson et al. (2011) outlined the compositional field where the formation of clay dispersions is possible. They identify two limiting conditions for avoiding the formation of a clay sol (see Figure 7-2):

- The ionic strength of the external solution needs to be ≥ 25 mM.
- The fraction of the divalent ion in the clay needs to be $\geq 90\%$.

The relationship in Figure 7-2 can be compared with the cation concentrations generally expected in contact with fresh or degraded hydrated cement, or more specifically, with the values calculated by Gaucher et al. (2005). Even for the longest timeframe considered (up to 100,000 years), they predict sufficiently high Ca concentrations at the bentonite–shotcrete interface to avoid the dispersion of clay to form a sol. This strongly indicates that the process is not relevant for the design used in case of the Silo.

Moreover, experimental data from sedimentation and free swelling tests by Birgersson et al. (2010, 2011) indicate that the upper boundary of the sol formation zone as shown in Figure 7-2 may be very pessimistic.

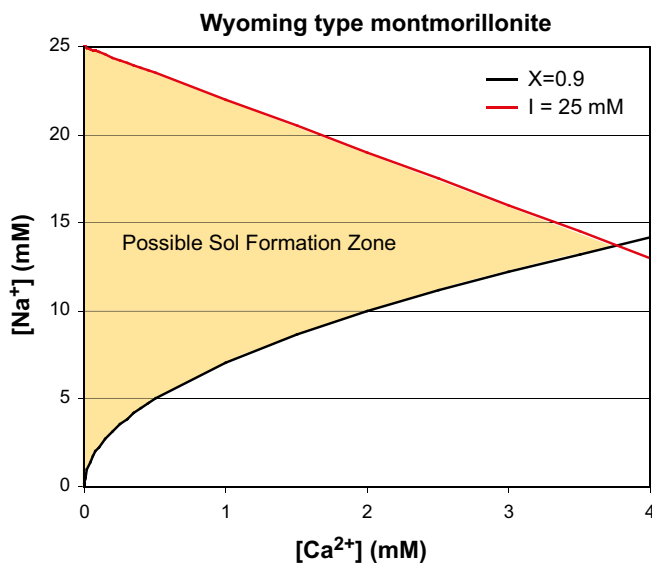

Figure 7-2. Outline of the parameter space for the possible formation of a disperse sol of Wyoming type montmorillonite in equilibrium with an external Ca/Na-chloride solution. The lower curve ($X=0.9$) represents a Ca fraction ≥ 0.9 in the clay, the upper curve represents an ionic strength ≥ 25 mM (which is the CCC for Wyoming-type montmorillonite in NaCl solution (Birgersson et al. 2010, 2011)).

Dependencies between processes and barrier variables

Table 7-18 summarises how the process influences and are influenced by all Silo variables. In addition, the handling of each influence in SR-PSU is indicated in the table and more thoroughly discussed in the text below.

Boundary conditions

The relevant boundary conditions are the bentonite composition and all processes influencing the composition of the external water and the transport of ions into the bentonite.

Model studies/experimental studies

There is a large number of publications about the swelling of montmorillonite in 1:1 electrolyte solutions. The DLVO theory describes the basic principles thereof (van Olphen 1963). In case of divalent cations, however, theoretical treatment beyond the DLVO theory is necessary (Guldbrand et al. 1984, Kjellander and Marčelja 1984, Kjellander et al. 1988).

To determine the critical coagulation concentration for montmorillonite in sodium chloride solutions studies were conducted by van Olphen (1963), Le Bell (1978), Hetzel and Doner (1993), Abend and Lagaly (2000), Wold (2003), Lagaly and Ziesmer (2003), Tombács and Szekeres (2004), Laaksoharju and Wold (2005) and Birgersson et al. (2010). Generally it is assumed that the mechanism for the coagulation of montmorillonite in sodium chloride are edge-face interactions (e.g. Lagaly and Ziesmer 2003, Tombács and Szekeres 2004, Birgersson et al. 2010).

In mixed mono- and divalent systems, the composition of the exchangeable ions needs to be taken into account. In an empirical way, this can be done by outlining a sol formation zone (SFZ) as given in Figure 7-2. The possible colloid release at low ionic strength has further been investigated using swelling pressure cells (Birgersson et al. 2010).

Liu et al. (2009) and Neretnieks et al. (2009) modelled the swelling of Na-montmorillonite into fractures filled with water with low ionic strength (1:1 electrolyte). They used a force-balance model for spherical colloids (Petsev et al. 1993) which had been adapted to parallel clay layers. The force-balance model was calibrated and tested with data from free-swelling experiments (Dvinskikh et al. 2009).

Table 7-18. Direct dependencies between the process ‘montmorillonite colloid release’ and system component variables and a short note on the handling in SR-PSU.

Variable	Variable influence on process		Process influence on variable	
	Influence present? Yes/No	Description	Influence present? Yes/No	Description
Geometry	Potential effect depends on mass of barrier. Pore geometry has indirect influence through diffusion.	Process neglected (see overview section).	By definition if process occurs.	Neglected.
Temperature	Yes. Temperature effects ion exchange equilibria.	Neglected, see above.	No.	–
Hydrological variables	Directly affects erosion rate.	Neglected, see above.	No, but indirectly.	Neglected, see above.
Mechanical stresses	Stress due to swelling by definition.	Neglected, see above.	Indirectly, through geometry if erosion occurs.	Neglected, see above.
Material composition	By definition.	Neglected, see above.	By definition, if relevant.	Neglected, see above.
Water composition	By definition.	Neglected, see above.	By definition, if relevant.	Neglected, see above.
Gas variables	No direct influence, but H ₂ , CH ₄ and CO ₂ can influence water composition.	Neglected, see above.	No.	–

Natural analogues/observations in nature

Laaksoharju (2003) and Degueldre et al. (1996) demonstrate that the clay colloid concentration in low-ionic strength crystalline groundwaters is low despite the occurrence of swelling clays in fractures (Äspö and Grimsel rock laboratories, respectively).

Time perspective

The process in itself is relatively fast, but the overall rate of mass transfer (in comparison to the total mass of bentonite present) will be slow. As pointed out above, the process should not be relevant in any of the reference periods due to the supply of Ca by the cementitious materials.

Handling in the safety assessment SR-PSU

Before saturation: The process is neglected.

After saturation: The process is neglected, because all available evidence points to a sufficiently high Ca concentration at the bentonite–shotcrete interface.

Handling of uncertainties in SR-PSU

There is good understanding of the process at a macroscopic level, which is sufficient to identify the critical mechanisms and limiting chemical conditions. However, these uncertainties are not relevant, as the process can be neglected. Where the process does take place, there are uncertainties regarding the quantification of actual mass loss of montmorillonite.

7.4.13 Microbial processes

Overview/general description

See BMA (5.4.8) section for a general overview.

Dependencies between microbial processes and Silo concrete barrier variables

For details of the variables see BMA section for dependence on microbial processes and BMA concrete variables

Dependencies between microbial processes and Silo bentonite barrier variables

Table 7-19 shows how microbial processes are influenced by and influence all SFR Silo bentonite barrier variables. The handling in SR-PSU is also indicated in the table and further described under the relevant heading. Several of the processes have been described previously in relation to the SFR waste systems (Pedersen 2001).

Geometry; Porosity and the pore characteristics will influence microbial mobility in the bentonite barriers. Any pore larger than about 1 µm will be available for migration microorganisms. As microorganisms generally are abundant in commercial bentonites (Svensson et al. 2011), they will be present at start and do not need to migrate into the barrier from groundwater or waste areas. During swelling and saturation, microbes will migrate with the groundwater until swelling restricts transport in the bentonite barrier due to pore sizes smaller than 0.2 µm diameter. Many microorganisms follow gradients such as those that may form over the clay barriers in between outside groundwater in the rock and the waste concrete barriers. A large pore size in the bentonite barrier will consequently favour mobility of microorganisms present in commercial bentonite and in groundwater to and from the Silo waste container area.

Microbial destabilisation of montmorillonite due to iron reduction could be considered. It has been readily demonstrated that this process can occur with ferruginous nontronite-type clays (Kostka et al. 2002, Kim et al. 2004). It is not known to what extent a similar process can proceed with the type of clays to be used in the Silo.

Table 7-19. Direct dependencies between microbial processes and the defined Silo bentonite barrier variables and a short note on the handling in SR-PSU.

Variable	Variable influence on process		Process influence on variable	
	Influence present? Yes/No Description	Handling of influence How/If not – Why	Influence present? Yes/No Description	Handling of influence How/If not – Why
Geometry	Yes. Porosity and the pore characteristics influence microbial mobility in bentonite.	Process neglected.	Yes. Microbial iron reduction and sulphide formation may cause illitisation of montmorillonite, thereby changing porosity characteristics.	Process neglected.
Temperature	Yes. The rate of microbial processes increases with increasing temperature.	Process neglected.	Yes. In cases with high microbial activity, heat is generated, not likley in Silo bentonite.	Process neglected.
Hydrological variables	Yes. The extent of microbial processes increases with increasing flow. Microbial activity depend on availability of water and saturation	Process neglected.	No.	Process neglected.
Mechanical stresses	No.	–	No.	–
Material composition	Yes. Microbial process rates depend on the availability of organic materials and corrosion products from rock bolts such as hydrogen. Microorganisms are present in most commercial bentonites.	Process neglected.	Yes. Microbial processes may cause illitisation of montmorillonite.	Process neglected.
Water composition	Yes. The content of electron donors and acceptors and pH will influence microbial processes.	Process neglected.	Yes. Microbial processes will influence concentrations of pore water components, dissolved gases, E_h and to some extent pH.	Process neglected.
Gas variables	Yes. Hydrogen and methane can be oxidised by microbial processes.	Process neglected.	Yes. Microbial processes generate gases.	Process neglected.

Temperature; Microbial processes in the Silo bentonite barriers will be more rapid at high temperatures. In cases with high microbial activity, significant heat can be generated. Such activity would not be expected in the barriers themselves, but at the boundaries between wastes with high loads of wet organic material, heat may evolve. As the Silo waste is well contained in reinforced cement and bitumen, the availability to organic material over time is expected to be slow and a heat effect from microbial processes is probably negligible in the Silo bentonite barrier.

Hydrological variables; Microbial activity depends on availability of water and the degree of saturation. The activity is low at low water activity and increases with increasing water activity as has first been demonstrated in a full scale sand-bentonite barrier experiment (Stroes-Gascoyne et al. 1997).

Mechanical stresses; No effects have been identified.

Material composition; Microbial process rates depend on the availability of bentonite organic materials and corrosion products from corroding reinforcement, rock bolts and waste steel barrels such as hydrogen. Hydrogen that reaches microorganisms in the bentonite barrier will enhance microbial process rates. Microbial processes can degrade clay material via illitisation and can thereby contribute to the degradation of the bentonite barrier by reducing the swelling capacity and increasing the pore size.

Water composition; Microbial processes can influence water composition significantly by their reduction of electron donors during respiration, which will change states of oxidation and aggregation of important water components.

Gas variables; Hydrogen from anaerobic metal corrosion processes can be oxidised by microbial processes; a large activity is obtained if oxygen is present. Anaerobic hydrogen oxidation with sulphate has been identified as an important microbial process. This process outputs sulphide when hydrogen is oxidised with sulphate. Therefore, hydrogen may imply sulphide production where microbial life is possible in the barriers. Active microbes can produce gas if organic carbon is available for metabolism.

Dependencies between microbial processes and Silo cupola vault and backfill variables

The same applies as for “Dependencies between microbial processes and BMA vault and backfill variables” in section about 1BMA and 2BMA (5.4.8).

Boundary conditions

The most favourable barrier position for microbes, with respect to available energy, is on the barrier surfaces facing towards the wastes and the outside surfaces of the barriers facing groundwater environments. The growth of microbes would predominantly occur on these surfaces, locally generating large numbers of microbes, relative to the amounts of available sources of energy and electron acceptors. However, fermentation processes will proceed without access to external electron acceptors. The magnitude, direction and distribution of groundwater flow over Silo barriers will influence the transport of microbes and, much more importantly, the transport of electron acceptors to, and degradation products from, microbes dwelling in the Silo barrier systems. Oxygen is a very potent electron acceptor and in situations where oxygen gradients develop over the barriers, sulphuric and nitric acid production from sulphide and ammonium, respectively, is possible.

Model studies/experimental studies

The presence of microorganisms in commercial bentonite has been investigated in relation to the so called Alternative Buffer Experiment (ABM) at Äspö HRL (Eng et al. 2007). The analysis of different clays showed a significant diversity and numbers of microorganisms including anaerobic sulphate- and iron-reducing bacteria (SRB, IRB), autotrophic acetogens and aerobic bacteria in most of the clays. The presence of SRB in MX-80 has been demonstrated via cultivation previously (Masurat et al. 2010a). Molecular analysis of DNA confirmed the presence of indigenous SRB in all commercial clays analysed. The presence of IRB in all 11 tested brands of commercial bentonite (Svensson et al. 2011) implies that a risk for microbial destabilisation of montmorillonite due to iron reduction should be considered. It has been readily demonstrated that this process can occur with ferrous nontronite-type clays (Kostka et al. 2002, Kim et al. 2004). It is not known to what extent a similar process can proceed with the type of clays to be used in the Silo. Research has shown that IRB can develop extra-cellular nanowires for the transfer of electrons from the cells to ferric iron (Reguera et al. 2005). Other IRB uses organic compounds such as humic acids as electron shuttles. It cannot be excluded that these mechanisms for electron transfer allow IRB to seek position outside bentonite barrier and transfer electrons to ferric iron in the bentonite.

During the saturation phase, successions of different microbial populations and activities will develop. Such a succession has been followed in the Prototype repository at the Äspö HRL for a period of more than 5 years (Pedersen et al. 2004a, Eriksson 2008, Lydmark 2010). It was found that the proportion of oxygen in gas extracted from the backfill decreased over time from that in air (20.8%) to a range of 0.6–4%. Large numbers of methanotrophic bacteria were detected together with other aerobic bacteria and it was suggested that part of the reduction of oxygen could be a result of aerobic methane oxidation with oxygen and organic carbon in backfill and groundwater.

A full-scale experiment (Buffer-Container Experiment, BCE), with buffer material consisting of 50/50% bentonite/sand was performed at Atomic Energy of Canada Limited's (AECL) underground laboratory in Canada. The results showed that microbes, with a few exceptions, could only be cultured from buffer samples with a gravimetric water content of 15% or more, which is approximately equivalent to the water content in a 100% bentonite having a saturated density of 2,000 kg/m³ (Stroes-Gascoyne et al. 1997). Elevated temperatures had no killing effect on the microbes. These results were interpreted as an effect of limited availability of water. The result of the BCE raised questions about the survival of microbes, and especially SRB, in buffer materials in 100% bentonite and has subsequently led to detailed laboratory experiments (Pedersen et al. 2000a, b, Masurat et al. 2010b). The relevance of these results for the Silo is that microorganisms will be present in the GEKO/QI bentonites and microbial activity will be plausible after water saturation of the sand-bentonite barriers on the sides and top and bottom of the Silo.

Model studies on the influence of microbial processes on Silo barriers remains to perform. A model study of waste degradation in a concrete box has been performed in Olkiluoto, Finland (Small et al. 2008). There was a considerable heterogeneity within the experiment such that pH varied from 5.5 to 10 between wastes and the concrete barrier. It was found that microbial activity can reduce the high pH from concrete and shape the environment from a concrete influenced high pH type to a neutral pH type environment. Consequently, the high pH generated by concrete cannot be taken as a measure against microbial processes. The outcome of the Finnish experiment showed that microorganisms can change the environment from unfavourable (high pH) to favourable via their metabolic processes.

Test methods were developed by Rogers et al. (2003) to assess microbial influenced degradation of cement-solidified wastes. It was found that microbial biofilms that developed on the concrete surfaces promoted cement degradation by acid production. Sterile controls degraded initially, but the degradation ceased after about two weeks, while the microbial system continued to degrade the concrete. A study by Aviam et al. (2004) confirmed that biodegradation of cement is an important process to account for in radioactive waste disposal. Sulphur oxidising bacteria caused weight losses of the cement samples and fractures were observed in the test material.

Natural analogues/observations in nature

See Section 5.4.8.

Time perspective

See Section 5.4.8.

Handling in the safety assessment SR-PSU

According to the modelling done by Cronstrand (2007), pH in the bentonite will be slightly alkaline (pH 8–10) during the first 100,000 years, which favour microbial activity. However, since microbial activity is not expected to have any negative effects on the properties of the barrier, the effect has been neglected. In the waste part of the silo, the process is neglected as pH is expected to be hyperalkaline in the cement and concrete barriers closest to the waste during the first 100,000 years (Cronstrand 2007).

Handling of uncertainties in SR-PSU

Uncertainties in mechanistic understanding: The basic scientific mechanisms governing the described microbial processes are well understood but their relevance for the Silo barriers and extent in Silo barriers is not well known. Studies have not been performed under relevant SFR conditions. The effect of microbial activity on montmorillonite stability has not been studied, due to a lack of understanding of the rate controlling mechanisms.

Model simplification uncertainties: The modelling performed by Cronstrand (2007) does not take microbial processes into account.

Input data and data uncertainties: Microbial processes are not taken into account as there are no data to model.

Adequacy of references supporting the handling in SR-PSU

The references are judged to be adequate and sufficient to support the handling in SR-PSU. All supporting references are either peer-reviewed articles or documents which have undergone factual review.

7.4.14 Cementation in bentonite

Overview/general description

The process ‘cementation’ is used in the sense of a collective term to address processes which may lead to specific changes in mechanical properties/rheology and swelling behaviour of the bentonite material. According to this definition, it is directly tied to the effects of various other processes, in particular ‘alteration of impurities’, ‘dissolution/precipitation’ and ‘montmorillonite transformation’ (see Sections 7.4.4, 7.4.6 and 7.4.10) with regard to the hydraulic, swelling and rheological behaviour of the bentonite barrier. Cementation caused by the above processes is expected to result primarily from the (re-)precipitation of minerals in the bentonite pores. Typical mineral phases include gypsum/anhydrite, calcite and a range of silica minerals. The respective dissolved constituents may be supplied by the groundwater or may stem from the dissolution of montmorillonite or accessory minerals. The underlying precipitation processes may also take place in the sand fill, but are not expected to lead to cementation in this medium.

The main concerns regarding the effects of cementation are increases in hydraulic conductivity, reduction of swelling ability and decrease of plasticity. The beneficial properties of bentonite are the result of montmorillonite/water interaction; i.e. the formation of a clay gel. This explains why bentonite with a high porosity (around 40%) still has a very low hydraulic conductivity. The effect of the precipitation of other minerals in the bentonite pores can be viewed as a dilution of the clay gel by comparatively large and rigid solids.

Dependencies between processes and barrier variables

Table 7-20 summarises how the process influences and are influenced by all Silo variables. In addition, the handling of each influence in SR-PSU is indicated in the table and more thoroughly discussed in the text below.

Table 7-20. Direct dependencies between the process cementation in bentonite and system component variables and a short note on the handling in SR-PSU.

Variable	Variable influence on process		Process influence on variable	
	Influence present? Yes/No Description	Handling of influence How/If not – Why	Influence present? Yes/No Description	Handling of influence How/If not – Why
Geometry	No, but pore geometry has indirect influence through diffusion.	See Sections 7.4.2, 7.4.4, 7.4.6, 7.4.10.	Pore geometry is influenced by definition.	See Sections 7.4.4, 7.4.6, 7.4.10.
Temperature	Yes. Temperature effects chemical equilibria.	See Sections 7.4.4, 7.4.6, 7.4.10.	No.	–
Hydrological variables	Fast water flows at border of bentonite barrier can increase reaction rates.	See Sections 7.4.4, 7.4.6, 7.4.10.	No, but indirectly through changes in geometry and material composition.	See Sections 7.4.4, 7.4.6, 7.4.10.
Mechanical stresses	No, but possibly indirectly through pore geometry and diffusion.	See Sections 7.4.4, 7.4.6, 7.4.10.	No, but indirect through pore geometry and volume changes.	See Sections 7.4.4, 7.4.6, 7.4.10.
Material composition	By definition.	See Sections 7.4.4, 7.4.6, 7.4.10.	By definition.	See Sections 7.4.4, 7.4.6, 7.4.10.
Water composition	By definition.	See Sections 7.4.4, 7.4.6, 7.4.10.	By definition.	See Sections 7.4.4, 7.4.6, 7.4.10.
Gas composition	No, but indirect, since pCO ₂ can influence water composition.	See Sections 7.4.4, 7.4.6, 7.4.10.	No.	–

Boundary conditions

The relevant boundary conditions are those of the processes ‘alteration of impurities’, ‘dissolution/precipitation’ and ‘montmorillonite transformation’ (see Sections 7.4.4, 7.4.6 and 7.4.10).

Model studies/experimental studies

The various processes that may cause cementation are treated separately under the processes ‘alteration of impurities’, ‘dissolution/precipitation’ and in particular ‘montmorillonite transformation’ (see Sections 7.4.4, 7.4.6 and 7.4.10).

For a KBS-3 type repository, there are various publications on field tests (LOT) available (e.g. Pusch 1977, Pusch et al. 1998, Karnland et al. 2000, where the effects of cementation (in these cases caused by temperature gradients) on shear strength and hydraulic conductivity are described.

Natural analogues/observations in nature

Most relevant for the present case are the cementation effects that may result from interaction with highly alkaline solutions, see Section 7.4.10.

Time perspective

See also Section 7.4.10.

Handling in the safety assessment SR-PSU

Before saturation: The underlying processes are not modelled explicitly.

After saturation: Alteration of impurities and accessory minerals is modelled explicitly for different time periods with different gradients. The model outcomes are used to assess the status of relevant safety functions. See also Sections 7.4.4, 7.4.6 and 7.4.10.

Handling of uncertainties in SR-PSU

Uncertainties are the same as those of the processes ‘alteration of impurities’, ‘dissolution/precipitation’ and ‘montmorillonite transformation’ (see Sections 7.4.4, 7.4.6 and 7.4.10).

7.4.15 Metal corrosion

The concrete barriers in the silo comprise the reinforced bottom plate, the silo cylinder wall, the shaft walls and the concrete lid on the top of the cylinder. The silo also contains shotcrete and rock bolts in the rock walls. The metal used for reinforcement and rock bolts is carbon steel. In the silo, the concrete grout surrounding the waste packages, the bentonite outside the concrete cylinder and the remaining void filled with sand or gravel do not contain any metal.

In the silo, the major source of metals (iron/steel, aluminium and zinc) is found in the waste packages (Moreno et al. 2001). Corrosion of metallic waste and metals in waste packaging is described in the **Waste process report**.

In the silo, metal corrosion of reinforcement bars is of importance for predicting degradation of the concrete cylinder and estimating the total gas formation rates.

Overview/general description

A general description of steel corrosion related to reinforced concrete is given in Section 5.4.9 for the BMA vault. The same type of steel reinforcement bars, rock bolts and concretes are used in the silo as in the BMA vault. Therefore the same general description given for BMA applies also for the silo.

Handling in the safety assessment SR-PSU

The metal corrosion of reinforcement bars in the silo concrete barriers, rock reinforcements and rock bolts is considered in the safety assessment in terms of:

- Evolution of redox conditions.
- Contribution to gas formation in the silo.
- Degradation of the concrete cylinder (e.g. decrease in mechanical strength and possible crack formation). The sorption capacity of reinforced concrete in the silo is not assumed to be influenced by the formation of corrosion products.

Adequacy of references supporting the handling in SR-PSU

The references are judged to be adequate and sufficient to support the handling in SR-PSU. All supporting references are either peer-reviewed articles or documents which have undergone factual review. Other references have been used for general background information, and not all of these have been peer-reviewed to the same standard.

7.4.16 Gas formation

Gas formation is important within the silo barriers as it will increase the pressure of the system once the saturation limit of the water phase is reached, i.e. when no further gas can be dissolved. Elevated pressure could lead to gas transport through the porous concrete surrounding the waste packages, see Section 7.2.3 or, if the gas is trapped, enhanced transport of contaminated water, see Section 7.5, rupturing of the barrier structure, and/or release of radioactive gas.

The waste packages are the main source for gas formation in the silo (Moreno et al. 2001). The different chemical processes causing gas formation in the waste packages are described in the **Waste process report**.

In the silo, hydrogen evolving corrosion of the reinforcement bars in the concrete structures will contribute to the total gas formation rates (Moreno et al. 2001). Other potential sources of gas are through microbial degradation of organic material (methane) and radiolysis of water (hydrogen). Microbial degradation in silo barriers is described in more detail in Section 7.4.13.

Overview/general description

An overview of metal corrosion in the silo barriers is given in Section 7.4.15. A general description of hydrogen evolving corrosion and gas formation is given in Section 5.4.9 and 5.4.10 respectively for the BMA vault. The same types of materials susceptible to gas formation are used in the silo as in the BMA vault. Therefore the same general description given for BMA applies also for the silo.

Handling in the safety assessment SR-PSU

Hydrogen evolving corrosion of reinforcement bars in the silo concrete barriers, rock reinforcement and rock bolts is considered in the safety assessment in terms of:

- Gas formation in the silo.
- Influence on gas transport, including radioactive gas.
- Pressurisation of the silo construction, which may cause displacement of radioactive pore water and may create fractures.

Adequacy of references supporting the handling in SR-PSU

The references are judged to be adequate and sufficient to support the handling in SR-PSU. All supporting references are either peer-reviewed articles or documents which have undergone factual review. Other references have been used for general background information, and not all of these have been peer-reviewed to the same standard.

7.5 Radionuclide transport

7.5.1 Speciation of radionuclides

This process describes the speciation of radionuclides; i.e. the establishment of all chemical equilibria determining the thermodynamically and kinetically stable chemical forms of radionuclides in bentonite pore solutions. In addition to typical reactions in solutions, these equilibria include redox reactions as well as the formation of sorbed radionuclide species (the formation of radionuclide solid phases is also considered, but should not be relevant in the bentonite barrier). Radionuclide sorption is addressed separately under the process sorption (Section 7.4.3).

Speciation of radionuclides is directly tied in with the respective sorption and diffusion processes. In turn, speciation depends on the chemical conditions and concentrations of specific reactants in the bentonite pores.

Dependencies between processes and barrier variables

Table 7-21 summarises how the process influences and are influenced by all Silo variables. In addition, the handling of each influence in SR-PSU is indicated in the table below.

Table 7-21. Direct dependencies between the process ‘speciation of radionuclides’ and system component variables.

Variable	Variable influence on process		Process influence on variable	
	Influence present? Yes/No	Description	Handling of influence How/If not – Why	Influence present? Yes/No
Geometry	No, but indirectly	since pore width and geometry can influence porewater composition.	Not considered.	No.
Temperature	Yes.	Temperature affects chemical equilibria.	Effect on equilibria is considered in speciation models using thermodynamic data or approximations.	No.
Hydrological variables (pressure and flows)	No (no direct influence on speciation).		–	No.
Mechanical stresses	No (possibly indirectly through geometry and porewater composition, see there).		Not considered.	No.
Material composition	No, but indirectly through porewater composition.		See water composition.	No. Radionuclides are present only at trace concentrations.
Water composition	Yes.	Water composition directly affects speciation.	Water composition considered in speciation modelling.	Yes. Speciation affects the chemical form of the dissolved radionuclides and in that sense water composition. However, radionuclide concentrations are at trace levels and do not influence bulk water composition.
Gas variables	No, but indirectly by influencing water composition.		See water composition.	No Radionuclides are present only at trace concentrations, their aqueous speciation does not influence bulk gas composition.

Boundary conditions

Boundary conditions for radionuclide speciation in the bentonite are the concentration and speciation of radionuclides in the adjacent system components, as well as the physical-chemical conditions (water composition and related variables, temperature).

Model studies/experimental studies

See Section 5.5.1.

Natural analogues/observations in nature

See Section 5.5.1.

Time perspective

See Section 5.5.1.

Handling in the safety assessment SR-PSU

This process is only relevant after saturation and in case of a release of radionuclides (failure of waste package).

The speciation of radionuclides is based on thermodynamic data (i.e. equilibrium assumption).

It is used to assess their transport properties in the barrier. This concerns mainly sorption, where calculation speciation directly feeds into the selection of sorption coefficients. Speciation is also used to assess the predominant charge of radionuclides in the assignment of diffusion behaviour. If relevant, radionuclide speciation could also be used to define solubility limits, but this is not done in the SR-PSU safety assessment.

Handling of uncertainties in SR-PSU

Uncertainties in mechanistic understanding

The basic understanding of the process is well developed. In cases of some radionuclides, there are still uncertainties in understanding and modelling their interaction with certain ligands (e.g. organic ligands, especially ISA; dissolved silica; mixed hydroxo-carbonato complexes).

Model simplifications uncertainties

Calculated solubility limits are valid for the underlying set of chemical conditions.

Input data and data uncertainties

Input data to quantitatively describe the process are thermodynamic data and water compositions. The uncertainty of thermodynamic data (or of the calculations) can be estimated. Uncertainties in water composition can be handled by considering bounding conditions.

Input data to quantifying the process in consequence calculations are solubility limits for radionuclides. Their uncertainties can be estimated. For sorption, which is also closely linked to speciation, see Section 7.4.3.

7.5.2 Transport of radionuclides in the water phase

The radionuclide transport modelling for the silo is very similar to the modelling of BMA (see corresponding process description for BMA (Section 5.5.2)), but there are a few differences:

- An extra calculation case, “gas driven advection”, is considered for the silo, due to the possibility for a significant gas pressure to build up in the silo, leading to a possible expulsion of contaminated water. In this calculation case, a significantly increased release rate of radionuclides during a limited time period is considered. See the **Radionuclide transport report** for details.
- Another feature unique to the modelling of the silo is the modelling of diffusion from the bentonite-wall out to the rock. This is due to the fact that diffusion is expected to be the dominating transport process at the silo wall which has a very low hydraulic conductivity. See the **Radionuclide transport report** for details.

Dependencies between process and system component variables

Table 7-22 shows how transport of radionuclides in the water phase in the Silo system is influenced by the specified set of physical variables and how the process influences the variables.

Boundary conditions

The inner boundary for the radionuclide transport processes is the concentration of nuclides in the interior of the silo. The outer boundary is the concentration in the rock outside the repository.

Model studies/experimental studies

Radionuclide transport through the barriers in the silo has been studied in several earlier safety assessments (Wiborgh et al. 1987, Lindgren et al. 2001, Thomsson et al. 2008b). The conclusions from these studies are that the barrier system of the silo is very efficient and the radiological risk from releases from the silo are lower than from e.g. 1BMA, despite the fact that the silo has a much higher inventory of radionuclides.

Table 7-22. Direct dependencies between “Transport of radionuclides in the water phase” and system component variables and a short note on the handling in SR-PSU.

Variable	Variable influence on process		Process influence on variable	
	Influence present? Yes/No Description	Handling of influence How/If not – Why	Influence present? Yes/No Description	Handling of influence How/If not – Why
Geometry	Yes. Gives the volumes and areas available for transport.	Yes. Geometry variables are included in RN-transport model.	No.	–
Temperature	Yes.	No. Effects are negligible.	No.	–
Hydrological variables	Yes. Water fluxes are highly significant for advective transport of RN.	Yes. Detailed flow parameters are included in the RN model.	No.	–
Mechanical stresses	No.	–	No.	–
Material composition	Yes. Sorption properties are highly dependent on material composition.	Yes. Material specific K_d values are included in the RN model.	No.	–
Water composition	Yes. Sorption properties are dependent on water composition.	Yes. Considered in the selection of K_d data.	Yes.	The porewater concentration of radionuclides in all parts of the system is calculated.
Gas variables	Yes. Increased gas pressure might lead to the expulsion of contaminated water.	The effect is assessed in a separate calculation case with gas driven advection.	No.	–

Natural analogues/observations in nature

Not applicable.

Time perspective

Transport of radionuclides in the water phase will be relevant at all time scales in SFR.

Handling in the safety assessment SR-PSU

See the corresponding section for BMA.

Handling of uncertainties in SR-PSU

See the corresponding section for BMA.

Adequacy of references supporting the handling in SR-PSU

See the corresponding section for BMA.

7.5.3 Transport of radionuclides in the gas phase

See corresponding process description for BMA (Section 5.5.3).

8 1–5BLA

8.1 Thermal processes

8.1.1 Heat transport

Overview/general description

The heat transport process is described in the corresponding section for the BMA repository (See Section 5.1.1). This description also applies here.

Dependencies between process and system component variables

Table 8-1 shows how the process influences, and is influenced by, all system variables.

Table 8-1. Direct dependencies between the process “Heat transport” and the defined system variables and a short note on the handling in SR-PSU.

Variable	Variable influence on process		Process influence on variable	
	Influence present? Yes/No Description	Handling of influence How/If not – Why	Influence present? Yes/No Description	Handling of influence How/If not – Why
Geometry	Yes, the constitution of the system determine how heat flows.	The process is not explicitly handled. See Section 5.1.1.	No.	
Temperature	Yes. Temperature differences is an requirement for the process.	The process is not explicitly handled. See Section 5.1.1.	Yes. Heat transport tends to even out temperature differences.	The process is not explicitly handled. See Section 5.1.1.
Hydrological variables	Yes. Water flow may transport heat. Heat capacities may change with saturation state and aggregation state.	The process is not explicitly handled. See Section 5.1.1.	Yes, through e.g. convection. The influence is however negligible because temperature differences are small.	The process is not explicitly handled. See Section 5.1.1.
Mechanical stresses	Yes, in principle as e.g. heat capacities may depend on stress state. The effect is however negligible.	The process is not explicitly handled. See Section 5.1.1.	Yes. Due to thermal expansion/contraction.	The process is not explicitly handled. See Section 5.1.1.
Material composition	Yes. Different materials have different thermal conductivities, specific heats etc.	The process is not explicitly handled. See Section 5.1.1.	No.	
Water composition	Yes in principle as e.g. heat capacities may depend on composition. The effect is however negligible.	The process is not explicitly handled. See Section 5.1.1.	No.	
Gas variables	Yes. Gas flow may transport heat.	The process is not explicitly handled. See Section 5.1.1.	Yes, but relevant only during the operational phase when the repository is not water saturated.	The process is not explicitly handled. See Section 5.1.1.

Boundary conditions

See Section 5.1.1.

Model studies/experimental studies

See Section 5.1.1.

Natural analogues/observations in nature

See Section 5.1.1.

Time perspective

See Section 5.1.1.

Handling in the safety assessment SR-PSU

See Section 5.1.1.

Handling of uncertainties in SR-PSU

See Section 5.1.1.

8.1.2 Phase changes/freezing

Overview/general description

The description made for the BMA repository (Section 5.1.2) apply also here.

Dependencies between process and system component variables

Table 8-2 shows how the process influences, and is influenced by, all system variables.

Boundary conditions

See Section 5.1.2.

Model studies/experimental studies

See Section 5.1.2.

Natural analogues/observations in nature

See Section 5.1.2.

Time perspective

See Section 5.1.2.

Handling in the safety assessment SR-PSU

See Section 5.1.2.

Handling of uncertainties in SR-PSU

See Section 5.1.2.

Table 8-2. Direct dependencies between the process “Phase changes/freezing” and the defined system variables and a short note on the handling in SR-PSU.

Variable	Variable influence on process		Process influence on variable	
	Influence present? Yes/No Description	Handling of influence How/If not – Why	Influence present? Yes/No Description	Handling of influence How/If not – Why
Geometry	Yes. Freezing point is influenced by confinement geometry if it is small (sub microns). Frost susceptibility depends on pore geometry.	Freezing points (or temperature intervals) are estimated for each component material.	Yes. Pore geometries may be different after freezing. Fractures may have been created or widened. Cycles of freezing/thawing may cause particle sorting.	Altered hydraulic conductivity after permafrost period.
Temperature	Yes. Freezing occur at a certain temperature or in a certain temperature interval.	Freezing points (or temperature intervals) are estimated.	Yes. Freezing releases energy. Thawing consumes energy.	Neglected as the influence of the repository on temperature evaluation is minor. See also Section 5.1.1.
Hydrological variables	Yes. Water pressure has a minor influence on freezing point.	Insignificant, unless very high pressures.	Yes. Freezing may cause pressure increase and affect water flow. Freezing may also reduce conductivity (a completely frozen system does not flow).	The barrier function of concrete is considered lost after a freezing/thawing cycle.
Mechanical stresses	Yes. Pressure influences freezing point.	Insignificant, unless very high pressures involved.	Yes. Freezing and frost heave may induce stresses and strains.	Altered hydraulic conductivity after permafrost period. Effect on host rock is estimated.
Material composition	Yes. Freezing point is influenced by surface properties.	Freezing points (or temperature intervals) are estimated.	No.	
Water composition	Yes. Freezing point is influenced by type and concentration of solutes.	Estimated from water chemistry.	Yes. Freezing may change composition of remaining unfrozen water.	Neglected, because possible freezing is slow in comparison to diffusive and advective mass transfer.
Gas variables	No. Indirectly through dissolved gases.	Insignificant unless gas pressures are high. Handled via water composition.	No.	

8.2 Hydraulic processes

8.2.1 Water uptake and transport under unsaturated conditions

The barriers consist of the shotcrete on the rock surfaces, the unfilled empty space between the rock and the containers and the waste packages (containers).

The water filling (saturation) period is rather simple to describe and depends entirely on the rock hydrology and the sealing efficiency of the shotcrete. Water will flow into the vault and fill it up from the floor like a bathtub. No air is anticipated to be entrapped.

Dependencies between process and system component variables.

Table 8-3 summarises how the process influences and is influenced by all BLA variables. In addition, the handling of each influence in SR-PSU is indicated in the table.

Table 8-3. Direct dependencies between the process “Water uptake and transport under unsaturated conditions” in BLA and the defined variables and a short note on the handling in SR-PSU.

Variable	Variable influence on process		Process influence on variable	
	Influence present? Yes/No	Description Handling of influence How/If not – Why	Influence present? Yes/No	Description Handling of influence How/If not – Why
Geometry	Yes.	Process neglected.	No.	–
Temperature	No, but indirect through water viscosity.	Negligible.	No.	–
Hydrological variables	Yes, basic variables.	Process neglected.	No.	–
Mechanical stresses	No.	–	No.	–
Material composition	No filling material.	–	No filling material.	–
Water composition	Yes, through water viscosity.	No, neglectable.	No.	–
Gas variables	Yes, via gas pressure and degree of saturation.	No – not important.	Yes, amount of gas and degree of saturation.	Process neglected.

Boundary conditions

The rock and the plug are the boundaries.

Model studies/experimental studies

No.

Natural analogues/observations in nature

Water filling of rock vaults (mines) is a well known process.

Time perspective

The timescale or timescales on which the process occurs is documented, if such timescales can be defined.

Handling in the safety assessment SR-PSU

The water filling will be fast and this process is not expected to have any influence on safety and will thus not be treated.

8.2.2 Water transport under saturated conditions

Overview/general description

Since there will be no backfilling of the empty space surrounding the waste packages there is no flow resistance. The shotcrete on the rock surface will during the first about 100 years reduce the water flow in the vault past the waste but degradation and rock fall out will destroy that protection. After that period the vault will rather act as a sink and direct water flow in the rock towards the vault.

The most important mechanism under saturated conditions is transport of water in the liquid phase, which is driven by a water pressure gradient. This transport process can be described by Darcy’s law. See Section 5.2.2.

Dependencies between process and system component variables

Table 8-4 summarises how the process influences and is influenced by all BLA variables. In addition, the handling of each influence in SR-PSU is indicated in the table.

Boundary conditions

The rock and the plug are the boundaries of the vault but the entire rock mass will be included in the hydrological model.

Table 8-4. Direct dependencies between the process “Water transport under saturated conditions” in BLA and the defined variables and a short note on the handling.

Variable	Variable influence on process		Process influence on variable	
	Influence present? Yes/No	Description Handling of influence How/If not – Why	Influence present? Yes/No	Description Handling of influence How/If not – Why
Geometry	Yes.	Included in the model.	No.	–
Temperature	No, but indirect through water viscosity.	Negligible.	No.	–
Hydrological variables	Yes, basic variables.	Included in the model.	Yes.	Included in the model.
Mechanical stresses	No.	–	No.	–
Material composition	No filling material.	–	No filling material.	–
Water composition	Yes.	Included in the model.	No.	–
Gas variables	No, gas will escape.	–	No.	–

Model studies/experimental studies

No.

Natural analogues/observations in nature

Has not been directly studied.

Time perspective

The entire life time after water filling.

Handling in the safety assessment SR-PSU

The process water flow under saturated condition will be decisive for the safety assessment. The magnitude of water flux past the containers will vary with time and increase successively when the shotcrete is degraded. This flow will be modelled.

Timescales: The entire life time will be included. The processes can be divided into two different time periods; before and after degradation of the shotcrete but the shotcrete will be disregarded.

Boundary conditions: The rock will be included in the model. Different rock structures and boundary conditions will be used.

Handling of variables influencing this process: All the influencing variables in the table, except temperature, will be included in the analyses.

Handling of variables influenced by this process: All the influenced variables will be included in the analyses.

Handling of uncertainties in SR-PSU

The uncertainties refer entirely to the rock since there are no backfilling.

Uncertainties in mechanistic understanding: Water flow in fractures is well understood but the location of all fractures is not known.

Model simplification uncertainties: Rock is modelled as porous media which is not always very relevant.

Input data and data uncertainties: Rock hydraulic conductivity is not well known since the geometry and properties of all fractures are not known.

8.2.3 Gas transport/dissolution

Overview/general description

The generic concepts of gas transport and dissolution in BMA, with a focus on concrete barriers, are described in Section 5.2.3.

The BLA rock vaults do not contain engineered barriers, and the void surrounding the waste packages will not be backfilled. After the vaults are sealed, groundwater will seep in from surrounding rock, gradually filling the empty voids in waste packages and the vault. The shotcrete lining of the rock vault offers the only resistance to gas transport in the BLA vaults, and this resistance is unlikely to be significant. Therefore, despite the large gas generation potential of the wastes, pressure is not expected to build up or result in the expulsion of a significant amount of water (Moreno et al. 2001).

Handling in the safety assessment SR-PSU

All gases formed in the wastes and packagings can be assumed to be transported out from the vault into the geosphere without extensive pressure build-up.

Adequacy of references supporting the handling in SR-PSU

The reference is judged to be adequate and sufficient to support the handling in SR-PSU as it has undergone factual review. Other references have been used for general background information, and not all of these have been peer-reviewed to the same standard.

8.3 Mechanical processes

8.3.1 Mechanical processes

Overview/general description

The only mechanical processes foreseen are fall out of rock from the walls and roof, which will take place after the degradation of the shotcrete. The consequence will be that pieces of rock and shotcrete will fall down and stay on the floor and on the waste packages.

Dependencies between process and system component variables

Table 8-5 summarises how the process influences and is influenced by all BLA variables. In addition, the handling of each influence in SR-PSU is indicated in the table.

Boundary conditions

The rock surface and the plug are the boundaries.

Model studies/experimental studies

No.

Table 8-5. Direct dependencies between the mechanical processes in BLA and the defined variables and a short note on the handling in SR-PSU.

Variable	Variable influence on process		Process influence on variable	
	Influence present? Yes/No Description	Handling of influence How/If not – Why	Influence present? Yes/No Description	Handling of influence How/If not – Why
Geometry	Yes.	No, not important.	Yes by rock fallout.	No, not important.
Temperature	No.	–	No.	–
Hydrological variables	Yes, through Archimedes principle.	No, not important.	No.	–
Mechanical stresses	Yes, basic variable.	No, not important.	No.	–
Material composition	No filling material.	–	No filling material.	–
Water composition	No.	–	No.	–
Gas variables	No, gas will escape.	–	No.	–

Natural analogues/observations in nature

Rock fallout occurs frequently in rock vaults.

Time perspective

No analyses.

Handling in the safety assessment SR-PSU

The rock fallout from the roof and walls is not expected to influence the performance since it does not affect the water flow through the rooms and will thus not be analysed.

Handling of uncertainties in SR-PSU

No analyses.

8.4 Chemical processes

8.4.1 Advection and dispersion

Overview/general description

The general processes of advection and dispersion are described in detail in Section 5.4.1. Although the barrier systems in the BLA rock vaults are very different from those in the BMA rock vaults, the mechanistic principles for the processes of advection and dispersion are the same. Therefore, repetition is avoided throughout this section by referencing the process description for BMA (Section 5.4.1) when appropriate.

The BLA rock vaults do not contain engineered structures with any barrier function; the concrete floor and shotcrete lining of the vaults are not envisaged to have any flow limiting properties. Therefore, no safety function for limited advective transport applies for the BLA barriers (see Section 3.2). In the safety assessment SR-PSU, the water in the voids of the BLA rock vaults are cautiously assumed to be completely mixed. With this assumption, the dispersion of solutes in these vaults is regarded as instant, resulting in homogeneous concentrations throughout the entire water filled void volume. Advective transport is therefore important for calculating solute transport into and out from these void volumes only. The extent to which this process occurs is governed by the dissolved solute concentrations and the local groundwater flow (described separately in Sections 8.2.1 and 8.2.2).

Dependencies between process and system component variables

Table 8-6 shows how the advection and dispersion processes influence, and are influenced by, a set of system variables. In addition, the handling of each influence in SR-PSU is indicated in the table.

Influence by geometry

No direct influence has been identified.

Advective transport in the void volume is affected indirectly by geometry through water transport, see Sections 8.2.1 and 8.2.2.

Influence on geometry

No direct influence has been identified.

Table 8-6. Dependencies between the processes of “advection and dispersion” and the system component variables for the BLA barriers and a short note on the handling in SR-PSU.

Variable	Variable influence on process		Process influence on variable	
	Influence present? Yes/No Description	Handling of influence How/If not – Why	Influence present? Yes/No Description	Handling of influence How/If not – Why
Geometry	No direct influence. Indirect influence of geometry on water transport.	See Sections 8.2.1 and 8.2.2.	No direct influence identified.	
Temperature	No direct influence. Temperature affects thermal convection of groundwater through changes in density.	See Sections 8.2.1 and 8.2.2.	No direct influence. Temperature is influenced by redistribution of heat due to water transport.	See Sections 8.2.1 and 8.2.2.
Hydrological variables	Yes, magnitude, direction and distribution of water flow have a direct influence on advective transport.	Magnitude, direction, and distribution of water flow are variables included in near-field hydrogeological modelling.	No direct influence. Indirectly, advection-induced changes in water composition may affect viscosity and density.	
Mechanical stresses	No direct influence. Indirectly, mechanical stress imposed on the vault may cause rock fall-out with some influence on advective transport.		No direct influence identified.	
Material composition	No direct influence. Indirectly, reactions involving structural components may influence water composition.		No direct influence identified. Only indirect influence via water composition and advection-induced reactions involving structural components.	
Water composition	Yes, water composition determines magnitude of advective transport of solutes.	Dissolved concentrations are considered in solute transport calculations.	Yes, the water composition is influenced by advective transport of dissolved species, colloids and particles, and by mixing of different waters.	Advection-induced changes in water composition is included in solute transport modelling.
Gas variables	No direct influence identified.		No direct influence identified, but indirectly through water composition by affecting the concentration of dissolved gases, which affects the gas phase composition via Henry's law.	See Section 8.2.3.

Influence by temperature

No direct influence has been identified.

Temperature may affect water transport (Sections 8.2.1 and 8.2.2) by thermal convection through changes in the fluid density. This would indirectly influence advective transport. The effect is however judged to be negligible due to small temperature variations within the waste forms and between different parts of SFR.

Influence on temperature

No direct influence has been identified.

Heat may be redistributed as a result of water transport (Sections 8.2.1 and 8.2.2), and the mixing of different waters. Heat transport is further considered in Section 8.1.1.

Influence by hydrological variables

A direct influence has been identified.

Advective transport of solutes is controlled by the magnitude, direction and distribution of water flow driven by pressure differences. Other hydrological variables have indirect influences on advection through the process of water transport, a process further described in Sections 8.2.1 and 8.2.2.

Influence on hydrological variables

No direct influence has been identified.

Indirect effects due to advection-induced changes in the water composition that influence the physical properties of water are addressed in Section 8.1.2.

Influence by mechanical stresses

No direct influence has been identified.

Indirectly, mechanical stress imposed on the vault may induce rock fall-out which may have some influence on advection by affecting water transport (Sections 8.2.1 and 8.2.2).

Influence on mechanical stresses

No direct influence of advection and dispersion on the mechanical stresses in the BLA barriers has been identified.

Influence by material composition

No direct influence has been identified.

Indirectly, the material composition of structural components (i.e. concrete floor and shotcrete lining) in the BLA barriers may affect the extent of advective transport through e.g. dissolution/precipitation reactions, and the influence of these processes on the pore water concentrations.

Influence on material composition

No direct influence has been identified.

Indirectly, the material composition of the concrete floor and shotcrete lining may be influenced by advective transport via water composition and dissolution, precipitation and recrystallisation reactions (see Section 5.4.6) that may result from advection-induced changes in the water composition. This influence is judged negligible since the constructions are not attributed any post-closure barrier functions.

Influence by water composition

A direct influence has been identified.

The water composition has a direct influence by defining the magnitude of advective transport of the dissolved species. This influence is handled within SR-PSU by estimation appropriate concentrations in solute transport calculations. Furthermore, the salinity affects the density and viscosity of water and may therefore influence the advection and dispersion processes indirectly through water transport (Sections 8.2.1 and 8.2.2).

Influence on water composition

A direct influence has been identified.

The water composition is directly affected by the advective transport of dissolved species, colloids and particles. This is handled within SR-PSU by including advection-induced changes of the water composition in solute transport modelling. Indirectly, advective transport of dissolved species may induce dissolution, precipitation and recrystallisation reactions (see Section 5.4.6), which may influence the water composition.

Influence by gas variables.

No direct influence has been identified.

The presence of gas may influence the advective transport indirectly by creating locally unsaturated conditions, and changing the water flow pattern (bubbly flow). See further Sections 8.2.1 and 8.2.3.

Influence on gas variables

No direct influence has been identified.

The advective transport of dissolved gases will influence the gas composition and pressure indirectly by establishing equilibria between the gas and water phase.

Boundary conditions

The boundary conditions for the processes of advection and dispersion are the groundwater flow rates, the degree of water saturation and the groundwater chemical composition at the physical boundaries of the BLA vaults and the waste form.

Model studies/experimental studies

See Section 5.4.1.

Natural analogues/observations in nature

See Section 5.4.1.

Time perspective

Advective transport of solutes by flowing groundwater will be relevant at all time scales in the BLA vaults at SFR. A gradual loss of integrity of engineered structures, i.e. the vault floor and shotcrete lining presumed, in particular as a result of freeze damaging during permafrost. These structures are however not envisaged as having a flow limiting function.

Handling in the safety assessment SR-PSU

Advection is presumably the predominant transport process for solutes in the BLA barriers and is included in modelling of radionuclide release. In the SR-PSU safety assessment, the waters in the voids of BLA are assumed to be completely mixed, which implies infinite dispersion.

Gas-driven advection processes are considered in scenario calculations (cf. SKB 2008b).

Handling of uncertainties in SR-PSU.

Uncertainties in mechanistic understanding: Advection and dispersion processes can be considered to be a mature science and the conceptual uncertainties are small.

Model simplification uncertainties: The model simplifications are mainly related to the assignment of boundary conditions to reflect the changes in groundwater flow and chemical composition during different periods in time.

Input data and data uncertainties: Uncertainties in input data and data uncertainties are handled by assigning pessimistic values in modelling. The sensitivity to input data is checked by parameter variations and scenario analysis.

Adequacy of references supporting the handling in SR-PSU

The references are judged to be adequate and sufficient to support the handling in SR-PSU. All supporting references are either peer-reviewed articles or documents which have undergone factual review.

8.4.2 Diffusion

Overview/general description

Section 5.4.2 introduces the key generic concepts of diffusion. In the BLA vaults, there are no engineered barriers and the water-filled voids between the waste tanks, the concrete floor and shotcrete-lined rock walls and roof offer a negligible barrier to diffusion. The systems will be assumed to be completely mixed for the safety assessment, with advection dominated flow conditions. This is a conservative approach that removes the need to address diffusion within the voids and is consistent with previous modelling of the BLA (e.g. Lindgren et al. 2001).

8.4.3 Sorption

Overview/general description

The sorption processes in the cementitious material and the natural rock barrier of BLA vaults are the same as in the corresponding components of BMA, see Section 5.4.3. This holds for the general descriptions of processes and relevant solids as well as all individual radionuclides discussed there.

Boundary conditions

Relevant boundary conditions are those that control the transport of solutes to and from the surrounding rock; i.e. the boundary conditions of the processes advection and diffusion.

Model studies/experimental studies

See corresponding discussion for BMA in Section 5.4.3.

Natural analogues/observations in nature

See corresponding discussion for BMA in Section 5.4.3.

Time perspective

See corresponding discussion for BMA in Section 5.4.3.

Handling in the safety assessment SR-PSU

Before saturation, the process is neglected.

After saturation: radionuclide sorption on the cement-based components of BLA can be included in the modelling of radionuclide transport. Sorption is quantified using K_d values that are specific for each element (and oxidation state, where relevant). Process uncertainties can generally be expressed through the use of bounding K_d values.

Handling of uncertainties in SR-PSU

Uncertainties of sorption on shotcrete and crystalline rock material are the same as in case of BMA (cement and gravel), see Section 5.4.3.

8.4.4 Colloid stability, transport and filtering

Overview/general description

A general overview and description of colloid transport and filtering is provided in the corresponding section for the BMA barriers, i.e. Section 5.4.5, along with a discussion of colloid stability under repository conditions. Although the barrier systems in the BLA rock vaults are very different from those in BMA, the mechanistic principles for the processes of colloid transport and filtering are the same.

Colloid stability is dependent on both pH and ionic strength, due to their influence on the surface charge and thickness of the electric double layer (see further Section 5.4.5). The pH and water composition in the BLA vaults are expected to be different from that in the BMA, particularly due to the more limited amount of concrete used in the engineered structural components. As a result, highly alkaline, high ionic strength conditions are anticipated over a shorter period than in the BMA.

Colloid stability will be affected by the gradual reduction in pH and ionic strength as the cementitious material degrades. The effect may be complex as a lower pH generally reduces colloid stability, while a lower ionic strength increases colloid stability. The ionic strength of the groundwater under temperate conditions, prior to the period of ingress of glacial melt water, is sufficiently high in order to maintain a low concentration of stable colloids.

The BLA rock vaults do not contain engineered barrier structures, except for the concrete floor and shotcrete lining of the vault walls. The floors and shotcrete linings of the vaults are not envisaged to have any retention capability because of the small amounts of concrete and uncertain status over time. Transport related retention and filtration within the void volumes are therefore negligible. Therefore, the formation and stability of colloids have no influence on the barrier performance and are thus neglected in the safety assessment.

8.4.5 Aqueous speciation and reactions

Overview/general description

Section 5.4.7 introduces the key concepts behind aqueous speciation and reactions, and summarises temporal changes to the groundwater in the vicinity of SFR. The BLA rock vaults do not contain engineered barriers, and the void surrounding the waste packages will not be backfilled. The vault design therefore is very different from the BMA and the safety function is the low activity and quantity of wastes deposited, rather than the hydraulic and chemical functions of cement (SKB 2008b).

In the BLA rock vaults, concrete construction materials are limited to the concrete floor, shotcrete lining of the rock vault and concrete plugs of the access tunnels (SKB 2008). In 1BLA, the majority of the waste will not be conditioned and no concrete wastes will be deposited (**Initial state report**). Therefore, although alkaline conditions are anticipated due to the leaching of hydroxide from the concrete (Section 5.4.6), this period will be much shorter-lived than in the BMA.

The inputs and mixing of groundwater, waste leachate and concrete leachate over time will define the aqueous speciation and the reactions that occur in the void. The corrosion of the iron and steel in the waste will consume oxygen and create highly reducing conditions and iron corrosion products, as described in the **Waste process report** and Section 5.4.9. Organic compounds may be leached from the wide range of organic materials deposited in BLA. Both metal corrosion and organic degradation are affected by the ambient chemical conditions, therefore these processes may be rather different in the BLA rock vaults compared with other parts of the SFR. This is relevant, for example, to the fate of the large quantities of cellulose deposited in the BLA as degradation to isosaccharinic acid (ISA) involves an alkaline degradation pathway. Equally, the speciation and solubility of the corrosion and degradation products will be affected by the chemical conditions.

As described in Section 5.4.7, the groundwater composition will change over time, affecting the aqueous speciation and reactions in the rock vaults. If shoreline displacement occurs as described in SKB (2008b), the groundwater will consist of freshwater sometime after 1,000 years. The lower ionic strength and greater bicarbonate concentration may cause dissolution or precipitation reactions. Also, humic acids may be present at higher concentrations in the new groundwater, and the lower salinity will enhance the solubility of humic-like molecules that form through organic degradation processes in the waste. Following glaciation, the water chemistry will change again to glacial melt water and this may affect aqueous speciation and reactions further.

Dependencies between process and system component variables

Table 8-7 shows how the processes Aqueous speciation and reactions influence, and is influenced by, all defined BLA system variables. In addition, the handling of each influence in SR-PSU is indicated in the table and discussed more thoroughly in the text below. The system variables and their definition within this report are presented in Section 4.3.4.

Table 8-7. Dependencies between the processes Aqueous speciation and reactions and the BLA system component variables.

Variable	Variable influence on process		Process influence on variable	
	Influence present? Yes/No Description	Handling of influence How/If not – Why	Influence present? Yes/No Description	Handling of influence How/If not – Why
Geometry	No, although the surface area of the void boundaries and precipitated phases will influence aqueous speciation indirectly via water composition.	Not relevant.	No, although aqueous speciation has an indirect influence via water composition and reactions such as sorption (8.4.3), precipitation and dissolution, which in turn affect geometry.	Not relevant.
Temperature	Yes, temperature affects reaction rates and thermodynamic equilibria.	Repository temperature is an input to the geochemical modelling. Variations in temperature are assumed to be negligible, except during climate scenarios.	Yes, if endo- or exothermic reactions take place.	No, no major endo- or exothermic reactions anticipated.
Hydrological variables	Yes, pressure affects aqueous speciation. Indirect effects result from the aggregation state, the magnitude, direction and distribution of water flow, and the amount of water, via water composition.	Included in the geochemical modelling.	No, although, aqueous speciation can affect the aggregation state indirectly via water composition.	Not relevant.
Mechanical stresses	No, although pressure can affect the aqueous speciation indirectly via the equilibrium position of reactions that involve a phase change.	Not relevant.	No, although aqueous speciation may influence reactions that involve volume expansion, and so may influence mechanical pressure indirectly.	Not relevant.
Material composition	No, although concrete components will affect the aqueous speciation and reactions indirectly, via dissolution and water composition.	Not relevant.	No, although aqueous speciation may affect material composition indirectly via water composition and dissolution, precipitation and sorption (Section 8.4.3) processes.	Not relevant.
Water composition	Yes, water composition controls aqueous speciation and reactions. The indirect impact of gases (carbon dioxide, hydrogen, methane) is considered.	Included in the geochemical modelling.	Yes, aqueous speciation and reactions controls water composition including particulate phases.	Included in the geochemical modelling.
Gas variables	No, although gas solute-exchange could impact aqueous speciation indirectly, via water composition.	Not relevant.	No, although aqueous speciation and reactions could generate or use gases (also relates to microbial processes, see Section 8.4.6), i.e. have an indirect effect via water composition.	Not relevant.

Influence by geometry

No direct influence identified.

The geometry of the barriers is defined by the space between the waste packaging and the rock vault. Both the exposed surface area and the porosity of the concrete components will affect exchange between the concrete porewater and the water in the void via dissolution/precipitation reactions and water composition. The concrete geometry will therefore indirectly affect the evolution of the pH and ionic strength of the barrier porewater over time.

Aqueous speciation will also be affected indirectly by the surface area of the solid material in the barrier (e.g. the concrete floor, shotcrete lined walls, plugs, any precipitated phases and the shipping containers holding the waste). The greater the surface area, the higher the number of available binding sites for sorption of aqueous species. However, since there is a very low solid: solution ratio in these systems, sorption is judged negligible.

Influence on geometry

No direct influence identified.

Aqueous speciation determines sorption, precipitation and dissolution reactions and these reactions affect the volume of the vault void. This indirect effect is of negligible importance in the BLA barriers due to the low solid: solution ratio in these systems.

Influence by temperature

Yes, there is a direct influence.

Temperature is a fundamental factor in chemical reaction rates and the position of chemical equilibria and will be addressed (as a matter of course) in the geochemical modelling.

Influence on temperature

Yes, there is a direct influence but it is not significant.

Aqueous exothermic reactions are judged to be of minor importance to the temperature in the repository.

Influence by hydrological variables

Yes, there is a direct influence.

Pressure has a direct, although small, effect on aqueous speciation, which will be accounted for in the geochemical modelling.

Aqueous speciation is also affected indirectly by a number of hydrological variables in the BLA via water composition. Aggregation is important due to the freezing out of dissolved substances as ice crystals form (e.g. Belzile et al. 2002). Also, the magnitude, direction and distribution of water flow are important for controlling both the composition of the water entering the void and the rate and extent of water renewal, which affects the temporal development of the aqueous conditions.

Influence on hydrological variables

No direct influence identified.

There is an indirect effect via water composition since dissolved components such as salt affect the aggregation state through changes to the freezing point of water.

Indirect effects on hydrological variables can also occur via dissolution, precipitation and recrystallisation reactions, which can affect the volume of water, the degree of saturation and thus the pressure of water. However, these are of low importance in the BLA, where there is a low solid to solution ratio.

Influence by mechanical stresses

No direct influence identified.

Pressure change resulting from mechanical stress has an influence on the equilibrium position of reactions involving changes in the volume of the solid phases in the system, and therefore affects aqueous speciation. This, however, is an indirect effect with negligible influence on the function of the BLA barriers (i.e. void space). Mechanical stress may also cause fracturing of the concrete components, and enhance dissolution, but the low quantities of concrete in the BLA barriers mean this has negligible impact on the aqueous speciation and reactions.

Influence on mechanical stresses

No direct influence identified.

Precipitation and recrystallisation reactions can occur causing volume expansion of the solid phases in the BLA and barriers, increasing the mechanical pressure. This, however, is an indirect influence with negligible effect on the function of the BLA barriers, since they are essentially void space.

Influence by material composition

No direct influence identified.

The concrete components of the vaults will influence aqueous speciation and reactions indirectly via changes in water composition, particularly through pH and ionic strength alteration.

Influence on material composition

No direct influence identified.

The aqueous speciation will define the precipitation reactions that occur indirectly, via water composition, and will therefore influence the amount, composition and surface characteristics of the solid phases within the vault. However, the solid structures are minimal in the BLA barrier systems, thus this is judged negligible with regard to modelling the systems.

Influence by water composition

Yes, there is a direct influence.

The water composition defines the aqueous speciation. More specifically the redox conditions, pH, ionic strength, concentration of dissolved species, type and amount of colloids and/or particles and the amount and composition of dissolved gas define the aqueous phase and the speciation of each element within it, under the prevailing temperature and pressure conditions.

Influence on water composition

Yes, there is a direct influence.

The aqueous speciation controls the water composition and the solubility of the species within the system. The chemical species define the redox potential, pH, ionic strength, concentration of dissolved species, amount of colloids and particles and the amount and composition of dissolved gas. The aqueous speciation therefore affects the salinity, density and viscosity of the water.

Influence by gas variables

No direct influence identified.

The amount, composition, volume, and pressure degree of saturation of gases will influence the aqueous speciation indirectly via water composition, as these affect the degree of dissolution in the aqueous phase.

Influence on gas variables

No direct influence identified.

Aqueous speciation will affect the amount, composition, volume and pressure degree of saturation of gases, via water composition, as the saturation limit of dissolved gas is affected by pH and aqueous speciation. An example of this is the solubility of CO₂ in water, which is reduced at lower pH because H⁺ ions push the carbonate equilibria towards H₂CO₃ thus limiting further dissolution of CO₂.

Boundary conditions

The boundaries of this analysis are the barriers themselves with exchange of mass and heat from the waste/waste package and the surrounding geosphere considered.

Model studies/experimental studies

See Section 5.4.7.

Natural analogues/observations in nature

See Section 5.4.7.

Time perspective

The aqueous speciation and reactions within the BLA barriers are dependent on the external ground-water conditions and the input from the degrading waste and waste packaging over time.

Handling in the safety assessment SR-PSU

Aqueous speciation and reactions are central considerations in the geochemical models used for the BLA vaults.

Handling of uncertainties in SR-PSU

Uncertainties in mechanistic understanding: Uncertainties in mechanistic understanding of aqueous speciation and reactions are generic and not specific to the BLA vaults. They are therefore handled in the same way as for the BMA (Section 5.4.7).

Model simplification uncertainties: The major simplifications in the aqueous chemistry and reactions of the BLA barriers are that the voids are treated as mixed systems and that there is no sorption. The model simplification uncertainties described for the BMA (Section 5.4.7) are also relevant, i.e. the selection and simplification of parameters to define the system and the assumption of thermodynamic equilibrium.

Input data and data uncertainties: The greatest uncertainties in the data are associated with the input from the waste and waste packaging leachate, due to the high heterogeneity of the wastes and the associated challenges predicting the composition of the waste leachate over time. The groundwater chemistry is dependent on whether shoreline displacement occurs, thus this requires careful assessment.

Adequacy of references supporting the handling in SR-PSU

The references are judged to be adequate and sufficient to support the handling in SR-PSU. All supporting references are either peer-reviewed articles or documents which have undergone factual review.

8.4.6 Microbial processes

Overview/general description

See Section 5.4.8 about BMA for overview of microbial processes.

Dependencies between microbial processes and BLA vault and backfill variables

Table 8-8 shows how microbial processes are influenced by and influence all SFR BLA vaults and backfill variables. The handling in SR-PSU is also indicated in the table and further described under the relevant heading. Several of the processes have been described previously in relation to the SFR waste systems (Pedersen 2001).

Geometry; The large volumes of groundwater in the vaults will allow most types of microorganisms to be active in this system. For the period when the repository is open, and water is filling up the vault, microbial biofilms can develop on shotcrete. In the presence of oxygen, dense mats of biological iron oxides (BIOS) can develop (Ferris et al. 1999). This BIOS material will have a limited influence on the volume and dimensions of the vaults.

Temperature; BLA will offer the most favourable conditions for microbial growth as there are a lot organic material and non-solidified waste, but it also contains the lowest level of radionuclides.

Hydrological variables; The same as in BMA except that there is no buffer. However, the rock wall covered with shotcrete.

Mechanical stresses; Effects are not expected.

Table 8-8. Direct dependencies between microbial processes and the defined BLA vault and backfill variables and a short note on the handling in SR-PSU.

Variable	Variable influence on process		Process influence on variable		
	Influence present? Yes/No	Description Handling of influence How/If not – Why	Influence present? Yes/No	Description Handling of influence How/If not – Why	
Geometry	Yes.	There will be large volumes with groundwater; microbial activity is expected.	Process neglected.	Yes. Microbial production of sulphides will commence once anaerobic conditions evolve. Corrosion processes can accelerate.	Process neglected.
Temperature	Yes.	The rate of microbial processes increases with increasing temperature.	Process neglected as an increase in temperature is not expected.	Yes. In cases with high microbial activity, heat is generated, not likely in BLA.	Process neglected as the temperature will be set to ambient groundwater conditions.
Hydrological variables	Yes.	The extent of microbial processes increases with increasing flow.	Process neglected as the intruding groundwater will favour natural groundwater bacteria and restrict bacteria introduced by the waste.	Yes. Microbial biofilms may form on walls and waste, but effects will be limited.	Process neglected.
Mechanical stresses	No.	–	–	No.	–
Material composition	Yes.	Microbial process rates depend on the availability of organic materials and corrosion products such as hydrogen.	Process neglected as corrosion rates caused by e.g. SRB will be too low to be a problem.	Yes. Microbial processes and biofilms may degrade shotcrete.	Process neglected.
Water composition	Yes.	The content of electron donors and acceptors and pH will influence microbial processes.	Process neglected.	Yes. Microbial processes will influence concentrations of groundwater components, dissolved gases, Eh and to some extent pH.	Process neglected.
Gas variables	Yes.	Hydrogen and methane can be oxidised by microbial processes.	Process neglected.	Yes. Microbial processes generate gases. Risk for carbonation of shotcrete.	Process neglected.

Material composition; Microbial process rates depend on the availability of organic materials and corrosion products such as hydrogen. The conditions in BLA will most likely be very favorable.

Water composition; The content of electron donors and acceptors and pH will influence microbial processes. The conditions in BLA will most likely be very favorable.

Gas variables; Microbes are expected to both consume and produce gas in the BLA vaults.

Boundary conditions

The transport of nutrients, electronacceptors and electrondonors to the microbes and the removal of toxic waste products from the cells are crucial for growth. These processes cannot take place in absence of water.

Model studies/experimental studies

Model studies on the influence of microbial processes on BLA barriers remain to perform.

Natural analogues/observations in nature

See corresponding section for BMA, Section 5.4.8.

Time perspective

See corresponding section for BMA, Section 5.4.8.

Handling in the safety assessment SR-PSU

There will most likely be strong microbial activity inside the BLA vaults. The effect can still be neglected since no barrier performance is accounted for in the assessment.

Handling of uncertainties in SR-PSU

Uncertainties in mechanistic understanding: The basic scientific mechanisms governing the described microbial processes are well understood but their relevance for BLA barriers and extent in BLA barriers is not known. Studies have not been performed under relevant SFR conditions.

Model simplification uncertainties: No model is needed.

Input data and data uncertainties: Not relevant.

8.4.7 Degradation of rock bolts, reinforcement and concrete

Overview/general description

Metal and concrete are present in the rock bolts walls and the reinforcement in vault. The corrosion of the metal will be controlled by the same processes as described for the 1BMA barriers in Section 5.4.9. As for the 1BMA barriers (Section 5.4.10), metal corrosion will be the major gas-formation process in the plugs. The concrete degradation processes described for the 1BMA barriers in Section 5.4.6 are also relevant for the concrete components in BLA.

Handling in the safety assessment SR-PSU

The process can be neglected since no barrier performance is accounted for in the assessment.

8.5 Radionuclide transport

8.5.1 Speciation of radionuclides

Overview/general description

Radionuclide speciation is a fundamental process describing the establishment of all chemical equilibria determining the thermodynamically stable (or metastable) chemical forms of radionuclides in pore solutions. The general features of this process are independent of the specific environment. A more detailed process description is given in the corresponding chapter for BMA, see Section 5.5.1. The chemical environment expected in the BLA vaults is described in Section 8.4.5.

Dependencies between processes and barrier variables

Table 8-9 shows how the process speciation of radionuclides influence, and is influenced by, the system variables. In addition, the handling of each influence in SR-PSU is indicated in the table.

Handling in the safety assessment SR-PSU

Radionuclide speciation is only relevant after saturation and in case of a release of radionuclides. The speciation of radionuclides is calculated based on thermodynamic data (i.e. assuming equilibrium). Therefore, a qualitative representation of speciation (in particular of hydrolysis at high pH) is normally sufficient.

Radionuclide speciation could also be used to define solubility limits where relevant, but this is not done in the SR-PSU safety assessment.

8.5.2 Transport of radionuclides in the water phase

Table 8-9. Direct dependencies between the process ‘speciation of radionuclides’ and system component variables and a short note on the handling in SR-PSU.

Variable	Variable influence on process		Process influence on variable	
	Influence present? Yes/No	Description Handling of influence How/If not – Why	Influence present? Yes/No	Description Handling of influence How/If not – Why
Geometry	No.	Speciation is a molecular-level chemical process which is not influenced by geometry.	–	No.
Temperature	Yes.	Temperature will effect speciation.	Effect of temperature on equilibria is considered in speciation models using thermodynamic data or approximations.	No.
Hydrological variables	No.	–	No.	–
Mechanical stresses	No.	–	No.	–
Material composition	No, but indirectly through porewater composition.	See water composition.	No.	–
Water composition	Yes.	Water composition directly affects speciation.	Water composition is considered in speciation modelling.	Yes. Speciation effects the chemical form of the dissolved radionuclides and in that sense water composition. However, radionuclide concentrations are at trace levels and do not influence bulk water composition.
Gas variables	No, bit indirectly by influencing water composition.	See water composition.	No.	Radionuclides are only trace constituents and do not effect the bulk gas composition.

The radionuclide transport modelling for BLA follows the same mathematical description as the modelling of BMA (See corresponding process description for BMA (Section 5.5.2)).

Advection is explicitly included in the radionuclide transport modelling. However the calculation of water fluxes are performed in a calculation step separated from the radionuclide transport calculations.

Dependencies between process and system component variables

Table 8-10 shows how transport of radionuclides in the water phase in the BLA system is influenced by the specified set of physical variables and how the process influences the variables.

Table 8-10. Direct dependencies between “Transport of radionuclides in the water phase” and system component variables and a short note on the handling in SR-PSU.

Variable	Variable influence on process		Process influence on variable			
	Influence present? Yes/No	Description Handling of influence How/If not – Why	Influence present? Yes/No	Description Handling of influence How/If not – Why		
Geometry	Yes.	Gives the volumes and areas available for transport.	Yes.	Geometry variables are included in RN-transport model.	No.	–
Temperature	Yes.		No.	Effects are negligible.	No.	–
Hydrological variables	Yes.	Water fluxes are highly significant for advective transport of RN.	Yes.	Detailed flow parameters are included in the RN model.	No.	–
Mechanical stresses	No.		–		No.	–
Material composition	Yes.	Sorption properties are highly dependent on material composition.	Yes.	Material specific K_d values are included in the RN model.	No.	–
Water composition	Yes.	Sorption properties are dependent on water composition.	Yes.	Included in K_d data.	Yes.	The porewater concentration of radionuclides in all parts of the system is calculated.
Gas variables	No.		–		No.	–

Boundary conditions

The inner boundary for the radionuclide transport processes is the concentration of nuclides in the interior of the BLA vaults. The outer boundary is the concentration in the rock outside the repository.

Model studies/experimental studies

Radionuclide transport through the barriers in 1BLA has been studied in several earlier safety assessments (Wiborgh et al. 1987, Lindgren et al. 2001, Thomsson et al. 2008b). The conclusions from these studies are that radionuclide releases from 1BLA initially can be significant due to the lack of concrete barriers.

Natural analogues/observations in nature

Not applicable.

Time perspective

Transport of radionuclides in the water phase will be relevant at all time scales in SFR.

Handling in the safety assessment SR-PSU

The principles for the handling is the same as for BMA (Section 5.5.2). The local flow, the geometry and sorption is included in the model; however the lack of barriers makes the results significantly different.

Handling of uncertainties in SR-PSU

See the corresponding section for BMA.

Adequacy of references supporting the handling in SR-PSU

See the corresponding section for BMA.

8.5.3 Transport of radionuclides in the gas phase

See corresponding process description for BMA (Section 5.5.3).

9 BRT

9.1 Thermal processes

9.1.1 Heat transport

Overview/general description

The heat transport process is described in the corresponding section for the BMA repository (Section 5.1.1). This description also applies here.

Dependencies between process and system component variables

Table 9-1 shows how the process influences, and is influenced by, all system variables.

Table 9-1. Direct dependencies between the process “Heat transport” and the defined system variables and a short note on the handling in SR-PSU.

Variable	Variable influence on process		Process influence on variable	
	Influence present? Yes/No Description	Handling of influence How/If not – Why	Influence present? Yes/No Description	Handling of influence How/If not – Why
Geometry	Yes, the constitution of the system determine how heat flows.	The process is not explicitly handled. See Section 5.1.1.	No.	
Temperature	Yes. Temperature differences is a requirement for the process.	The process is not explicitly handled. See Section 5.1.1.	Yes. Heat transport tends to even out temperature differences.	The process is not explicitly handled. See Section 5.1.1.
Hydrological variables	Yes. Water flow may transport heat. Heat capacities may change with saturation state and aggregation state.	The process is not explicitly handled. See Section 5.1.1.	Yes, through e.g. convection. The influence is however negligible because temperature differences are small.	The process is not explicitly handled. See Section 5.1.1.
Mechanical stresses	Yes, in principle as e.g. heat capacities may depend on stress state. The effect is however negligible.	The process is not explicitly handled. See Section 5.1.1.	Yes. Due to thermal expansion/contraction.	The process is not explicitly handled. See Section 5.1.1.
Material composition	Yes. Different materials have different thermal conductivities, specific heats etc.	The process is not explicitly handled. See Section 5.1.1.	No.	
Water composition	Yes in principle as e.g. heat capacities may depend on composition. The effect is however negligible.	The process is not explicitly handled. See Section 5.1.1.	No.	
Gas variables	Yes. Gas flow may transport heat.	The process is not explicitly handled. See Section 5.1.1.	Yes, but relevant only during the operational phase when the repository is not water saturate.	The process is not explicitly handled. See Section 5.1.1.

Boundary conditions

See Section 5.1.1.

Model studies/experimental studies

See Section 5.1.1.

Natural analogues/observations in nature

See Section 5.1.1.

Time perspective

See Section 5.1.1.

Handling in the safety assessment SR-PSU

See Section 5.1.1.

Handling of uncertainties in SR-PSU

See Section 5.1.1.

References

See Section 5.1.1.

9.1.2 Phase changes/freezing

The description made for the BMA repository (Section 5.1.2) applies also here. From a freezing perspective, macadam is expected to behave similar to sand, i.e. the material is not frost susceptible and there is no freezing point depression due to geometrical restrictions.

Dependencies between process and system component variables

Table 9-2 shows how the process influences, and is influenced by, all system variables.

Boundary conditions

See Section 5.1.2.

Model studies/experimental studies

See Section 5.1.2.

Natural analogues/observations in nature

See Section 5.1.2.

Time perspective

See Section 5.1.2.

Handling in the safety assessment SR-PSU

See Section 5.1.2.

Handling of uncertainties in SR-PSU

See Section 5.1.2.

Table 9-2. Direct dependencies between the process “Phase changes/freezing” and the defined system variables and a short note on the handling in SR-PSU.

Variable	Variable influence on process		Process influence on variable	
	Influence present? Yes/No Description	Handling of influence How/If not – Why	Influence present? Yes/No Description	Handling of influence How/If not – Why
Geometry	Yes. Freezing point is influenced by confinement geometry if it is small (sub microns). Frost susceptibility depends on pore geometry.	Freezing points (or temperature intervals) are estimated for each component material.	Yes. Pore geometries may be different after freezing. Fractures may have been created or widened. Cycles of freezing/thawing may cause particle sorting.	Altered hydraulic conductivity after permafrost period.
Temperature	Yes. Freezing occur at a certain temperature or in a certain temperature interval.	Freezing points (or temperature intervals) are estimated.	Yes. Freezing releases energy. Thawing consumes energy.	Neglected as the influence of the repository on temperature evaluation is minor. See also Section 5.1.1.
Hydrological variables	Yes. Water pressure has a minor influence on freezing point.	Insignificant, unless very high pressures.	Yes. Freezing may cause pressure increase and affect water flow. Freezing may also reduce conductivity (a completely frozen system does not flow).	The barrier function of concrete is considered lost after a freezing/thawing cycle.
Mechanical stresses	Yes. Pressure influences freezing point.	Insignificant, unless very high pressures involved.	Yes. Freezing and frost heave may induce stresses and strains.	Altered hydraulic conductivity after permafrost period. Effect on host rock is estimated.
Material composition	Yes. Freezing point is influenced by surface properties.	Freezing points (or temperature intervals) are estimated.	No.	
Water composition	Yes. Freezing point is influenced by type and concentration of solutes.	Estimated from water chemistry.	Yes. Freezing may change composition of remaining unfrozen water.	Neglected, because possible freezing is slow in comparison to diffusive and advective mass transfer.
Gas variables	No. Indirectly through dissolved gases.	Insignificant unless gas pressures are high. Handled via water composition.	No.	

9.2 Hydraulic processes

9.2.1 Water uptake and transport during unsaturated conditions

Overview/general description

BRT is similar to BTF. The vessels will be filled with grout, surrounded by grout and the remaining part of the vault will be filled with macadam. Although the geometries are rather different the processes are similar.

The hydraulic processes involved in the water saturation evolution are thus the same as described for BTF (see Section 6.2.1).

The wetting will start with water filling of the macadam, which takes place at the same rate as the water inflow from the rock since there is no hydraulic resistance in the macadam. When the open voids have been filled, the wetting of the grout filled parts will start. This will take a much longer time and take place both through matrix flow and flow in the fractures.

Since the water filling is fast and the saturation of the grout is difficult to predict (depends to a large extent on the cracking), no calculation of saturation time will be done but the vault will be considered saturated from start.

The effect of gas production is treated in Section 9.2.3.

Dependencies between process and system component variables

Table 9-3 summarises how the process influences and is influenced by all BRT processes and how these effects are handled. In addition, the handling of each influence in SR-PSU is indicated in the table.

Since the process will not be handled it will not be further treated.

9.2.2 Water transport under saturated conditions

Overview/general description

Water flow in saturated porous material is a special case of unsaturated flow. The number of processes to consider is fewer (vapour flux, phase transitions and air phases do not exist). Those processes that are involved are essentially the same as for unsaturated conditions, but can vary widely in importance when compared with unsaturated conditions. See Section 6.2.2.

The hydraulic conductivity of the macadam backfill is rather high and ranges between 10^{-6} and 10^{-2} m/s depending on the grain size distribution. The hydraulic conductivity of grout depends very much on the quality. If it is free from fractures, the hydraulic conductivity may be very low. However, the existence of joints and probable cracks will dominate the hydraulic behaviour.

With time the concrete is expected to degrade and the sealing effect will eventually be completely lost. This will ultimately lead to a stack of residual products of mainly the ballast material with properties similar to the backfill.

When the BRT room has been water saturated, the water transport through the room is governed by the hydraulic gradient in the surrounding rock. The high hydraulic conductivity of the backfill compared to the concrete containment will direct the water flow to go above the containment and assure a very low hydraulic gradient through the containment (hydraulic contrast). The water transport through the containment and past the waste packages depends then very much on the occurrence of cracks and joints in the concrete containment. After degradation of the cement, the hydraulic cage effect will disappear and the water will flow through the confinement.

Table 9-3. Direct dependencies between the process “Water uptake and transport under unsaturated conditions” in BRT and the defined variables and a short note on the handling.

Variable	Variable influence on process		Process influence on variable	
	Influence present? Yes/No Description	Handling of influence How/If not – Why	Influence present? Yes/No Description	Handling of influence How/If not – Why
Geometry	Yes.	No. Process neglected.	No.	
Temperature	No, but indirect through water viscosity.	No.	Yes, wetting and drying effects.	No. Process neglected.
Hydrological variables	Yes, basic variables.	No. Process neglected.	Yes	No. Process neglected.
Mechanical stresses	Yes	No. Process neglected.	Yes	No. Process neglected.
Material composition	Yes, hydraulic conductivity and retention curve.	No. Process neglected.	No, but indirectly through erosion if it takes place.	No.
Water composition	Yes, mainly through the viscosity.	No. Process neglected.	No.	
Gas variables	Yes, via gas pressure and degree of saturation.	No. Process neglected.	Yes.	No. Process neglected.

Dependencies between process and system component variables

Table 9-4 summarises how the process influences and is influenced by all BRT variables and how these effects are handled.

Boundary conditions

Interaction between the backfill and the rock: A key issue for the water flow process is the interaction between rock and backfill of macadam. Water is conducted to the backfill mainly in the water-bearing fractures, which means that water saturation can be uneven. However, the high hydraulic conductivity of the backfill will make the water flow go rather evenly in the backfill.

Interaction between grout and the rock in the floor: The water flow from the floor through the grout below the vessels depends on how the fractures in the rock interact with possible cracks in the grout and on if there is a floor filling of Macadam.

Interaction between the backfill and the concrete structure: The high hydraulic conductivity of the backfill of Macadam will make the water flow go around the grouted vessel and form a well-defined boundary to the roof of the grouted structure.

Interaction with the plugs: The plugs will seal off the BRT vault from the access tunnels and prevent water leakage from the backfill material.

Model studies/experimental studies

There are numerous examples of water flow in concrete structures in engineering practice. Also, macadam has been investigated and used for engineering purpose in numerous tests and practices. Hence, no studies with explicit purpose to investigate the water flow in BRT like structures have been performed.

Natural analogues/observations in nature

Not applicable since the system is engineered. The macro-scale hydraulic properties of natural cements are not fully relevant to an engineered system.

Time perspective

The process starts when the BRT has reached full saturation and continues during the rest of the BRT lifetime. The properties of the grout will however vary during this time due to degradation.

Table 9-4. Direct dependencies between the process “Water transport under saturated conditions” in BRT and the defined variables and a short note on the handling.

Variable	Variable influence on process		Process influence on variable	
	Influence present? Yes/No	Handling of influence Description How/If not – Why	Influence present? Yes/No	Handling of influence Description How/If not – Why
Geometry	Yes.	Geometry included in the model.	No.	–
Temperature	No, but indirectly through water viscosity.	See row water composition.	No.	–
Hydrological variables	Yes, basic variables.	Variables in the model.	Yes.	Variables in the model.
Mechanical stresses	Yes.	Negligible since the water flow rate is low.	Yes.	Negligible since the water flow rate is low.
Material composition	Yes, hydraulic conductivity.	Sensitivity analyses.	No, but indirectly through transport of degraded cement.	See Section 9.4.1 Advection and dispersion.
Water composition	Yes, mainly through the viscosity.	Negligible since the change in viscosity is small.	No, but indirectly through transport of degraded cement.	See Section 9.4.1 Advection and dispersion.
Gas variables	No, since the process assumes water saturation.	–	No.	–

Handling in the safety assessment SR-PSU

The process water flow under saturated condition will be decisive for the safety assessment regarding the release of radionuclides.

The magnitude of water flow through the vessel is expected to vary with time and increase successively when the grout containment is degraded.

The following handling in the safety assessment is anticipated:

1. Definition of the initial state with specification of grout quality, backfill material and containment design.
2. Investigation of the degradation rate of the cement, which may be a function of several factors.
3. Determination of the hydraulic properties of degraded grout.
4. Modelling of the water flow through the BRT vault with different hydraulic boundary conditions.

Timescales: The entire life time of the repository will be included. The grout degradation process is described by several degradation states.

Boundary conditions: The rock will be included in the model. Different rock structures and boundary conditions will be used.

Handling of variables influencing this process: All the influencing variables in the table, except temperature, will be included in the analyses.

Handling of variables influenced by this process: All the influenced variables except temperature will be included in the analyses.

Handling of uncertainties in SR-PSU

Given the adopted handling in the safety assessment SR-PSU as described above, the handling of different types of uncertainties associated with the process will be summarised.

Uncertainties in mechanistic understanding: The general understanding of saturated flow in Macadam and concrete are rather good. The uncertainties are mainly related to the rock properties and the existence of cracks in the concrete, the degradation rate of the grout and the properties of the degraded grout.

Model simplification uncertainties: The water flow in the grout will probably be simplified to water flow in a porous media with properties that vary with time according to the expected degradation rate.

Input data and data uncertainties: The properties of the cracks in the grout, the degradation rate and the properties of the degraded grout have large uncertainties.

9.2.3 Gas transport/dissolution

Overview/general description

Key concepts of gas transport and dissolution in concrete barriers are described in Section 5.2.3. The given descriptions are also relevant for concrete grout inside and surrounding the reactor pressure vessels. The porosity of the concrete grout backfill is higher than in structural concrete and the larger pores result in a lower capillary pressure to resist the displacement of water. The grout is also structurally weaker than structural concrete, and so will fracture at lower pressures.

Handling in the safety assessment SR-PSU

All gases formed by corrosion of the reactor pressure vessels and reinforcement in the concrete fundamentals for the vessels can be assumed to be transported out from the vault into the geosphere without extensive pressure build-up.

9.3 Mechanical processes

9.3.1 Mechanical processes

External and internal load will change the stress in the barriers. Change in stress and loss of structural integrity may cause deformation and redistribution.

Overview/general description

A number of mechanical processes may occur in the macadam and the grout containment. The following is a list of mechanical processes in the **macadam**:

- Stresses caused by the own weight.
- Hydraulic stresses.
- Settlement by wetting.
- Deformation caused by stress changes.
- Creep deformations.
- Effects of grout degradation.
- Effects of displacements and fall out in the roof and walls of the rock vault.
- Effects of freezing.
- Stresses caused by gas formation.

When the macadam is water unsaturated, the capillary forces between the grains may affect the stresses from the own weight of the backfill to such an extent that the backfill will remain as a loose structure if the emplacement is done without compaction. When the backfill becomes water saturated, the capillary forces will disappear and the backfill may settle into a higher density and leave a open water filled slot at the roof of the cavern.

After full water saturation the effective stress is governing the mechanical behaviour. The effective stress is the difference between the total stress and the water pressure according to Equation 9-1. See e.g. Hansbo (1975).

$$\sigma' = \sigma - Au \quad (9-1)$$

where

σ' = effective stress

σ = total stress

u = pore water pressure

A = 1.0 for normal soils

The mechanical properties of the macadam depend on mainly the grain size distribution and the density. The density is in turn a function of the grain size distribution, the grain particle form and the compaction effort. See e.g. Andreasson (1973).

The **grout** may also be affected by a number of mechanical processes:

- Stresses caused by the own weight of the grout, the backfill and the vessels.
- Hydraulic stresses.
- Deformation caused by stress changes.
- Creep deformations.
- Effects of cement degradation caused by chemical processes.
- Indirect effects of displacements and fall out in the roof and walls of the rock vault.
- Stresses caused by corrosion of the reinforcement.
- Cracking.
- Effects of freezing.

Many of these processes are however insignificant for the behaviour.

In the long time perspective, the grout is expected to crack and be degraded by chemical processes. This will ultimately lead to a stack of residual products of mainly the ballast material with properties similar to the Macadam.

Dependencies between process and system component variables

Table 9-5 summarises how the mechanical processes influence and are influenced by all BRT variables and how these effects are handled.

Boundary conditions

The BRT has the rock as boundary. The different parts of the BRT have several boundaries.

Macadam

The macadam has the rock as a mechanical fixed outer boundary except for the process of rock fall out and rock displacements. The other boundary of the Macadam is the grout structure, which may interact mechanically with the Macadam. The most important interactions are the effects of cement degradation and the gas generation from inside the grout structure.

Grout

The grout has the macadam, the vessels and the rock under and beside the structure as boundaries. There is an interaction with the Macadam (see above). There is also an interaction with the grout filled vessels mainly through the gas production but also by the degradation of the cement. The rock under the structure behaves like a fixed mechanical boundary.

Plugs

The plugs will seal off the BRT vault from the access tunnels and prevent water leakage from the Macadam. However, the mechanical interaction may after long time be considerable. When the cement in the concrete plugs has been degraded the plugs will lose their strength and the Macadam will be compressed by the swelling bentonite. See also Section 6.3.1.

Table 9-5. Direct dependencies between the mechanical processes in BRT and the defined variables and a short note on the handling.

Variable	Variable influence on process		Process influence on variable	
	Influence present? Yes/No Description	Handling of influence How/If not – Why	Influence present? Yes/No Description	Handling of influence How/If not – Why
Geometry	Yes.	Included in the model.	Yes, since stresses always cause displacements.	Negligible since the displacements are small.
Temperature	Yes.	Negligible, since temperature changes and gradients are small.	No.	
Hydrological variables	Yes, e.g. the stresses change when the vault is filled with water.	Included in hydromechanical models.	Yes, displacements may cause water pressure changes.	Included in HM-models, but very small.
Mechanical stresses	Yes, since stresses cause displacements and creep.	Included in hydromechanical models.	Yes, since displacements cause stresses.	Included in HM models.
Material composition	Yes, determines the properties.	Sensitivity analyses.	No.	
Water composition	Indirectly through chemical effects on the concrete, which will be degraded.	See Section 9.4.5. The change in barrier function will be analysed.	No.	
Gas variables	Yes, gas pressure may be generated and cause stresses.	Will be modelled.	No.	

Model studies/experimental studies

No studies with explicit purpose to investigate the mechanical processes in BRT like structures have been performed, but macadam materials and concrete structures have been investigated and used for engineering purpose in numerous tests and practices.

Natural analogues/observations in nature

See Section 5.3.1.

Time perspective

See handling in the safety assessment.

Handling in the safety assessment SR-PSU

Some of the mechanical processes may affect safety and will be included in the safety assessment. All subprocesses listed under overview/description will be commented on.

Backfill of macadam

- Stresses caused by the own weight of the backfill.
- Settlement by wetting.

These processes take place but will not be analysed since there is a slot in the roof from the beginning.

- Hydraulic stresses.
- Creep deformations.

These are small and will not be considered. The hydraulic stresses after saturation are small since there are very small hydraulic gradients. Macadam is not sensitive to creep.

- Effects of concrete degradation.

Will be analysed, see also Section 9.4.5.

- Effects of displacements and fall out in the roof and walls of the rock vault.

Neglected, since the rock fallout from the roof and walls is not expected to influence the performance.

- Effects of freezing.

Will be analysed, see also Section 9.1.2.

- Stresses caused by gas formation.

Will be analysed, see also Section 9.2.3.

- Deformation caused by stress changes.

Will be analysed in connection with the other mechanical processes.

Concrete

- Stresses caused by the own weight of the concrete, the backfill and the waste packages.

Will be neglected.

- Hydraulic stresses.
- Creep deformations.

These are small and can be neglected. The hydraulic stresses after saturation are small since there are very small hydraulic gradients. Concrete is not sensitive to creep.

- Effects of concrete degradation caused by chemical processes.

The process is handled in Section 5.4 Chemical processes in this report. If the concrete degradation is significant, the possible change in barrier function may be analysed.

- Indirect effects of displacements and fall out in the roof and walls of the rock vault.

Not very significant effects and may probably be neglected since it will only cause small changes in properties of the sand.

- Stresses caused by corrosion of the reinforcement.
- Cracking.

These will contribute to the degradation. The handling is described in Section 9.4.5.

- Effects of freezing.

Will contribute to the degradation; see also Section 9.1.2.

- Stresses caused by gas generation.

These will probably be small since the gas can escape through the concrete cracks but this process will be investigated (see also Section 9.2.3).

- Interaction with the waste packages.
- Deformation caused by stress changes.

Can be disregarded before the concrete degradation but may be important during and afterwards.

The concrete will crack and completely change its properties with time. The degradation rate and residual products should be investigated in order to predict the change in properties with time. The concrete may be modelled as completely degraded with properties similar to sand or gravel after a certain time.

Timescales: The entire life time will be included. The processes can be divided into two different time periods; before and after degradation of the concrete.

Boundary conditions: The rock will constitute the boundary in the analyses.

Handling of variables influencing this process: All the influencing variables in the table, except temperature, will be included in the analyses

Handling of variables influenced by this process: The influenced variables (geometry, hydraulic variables and mechanical stresses) will be included in the analyses.

Handling of uncertainties in SR-PSU

Given the adopted handling in the safety assessment SR-PSU as described above, the handling of different types of uncertainties associated with the process will be summarised.

Uncertainties in mechanistic understanding:

Backfill

The mechanical and hydraulic properties of Macadam are well known and the related mechanical processes well understood.

Concrete

The mechanical properties of the un-degraded concrete are well known and the mechanical processes well understood. The properties during and after degradation are more uncertain. A way to overcome these uncertainties may be to treat the concrete as completely degraded and turned into sand after a certain time.

Model simplification uncertainties: The lack of knowledge of the properties of the degraded concrete may make it necessary to treat the concrete as completely degraded and turned into sand after a certain time.

Input data and data uncertainties: See model simplifications.

Adequacy of references supporting the handling in SR-PSU

The references are judged to be adequate and sufficient to support the handling in SR-PSU. All supporting references are either peer-reviewed articles or documents which have undergone factual review. Other references have been used for general background information, and not all of these have been peer-reviewed to the same standard.

9.4 Chemical processes

9.4.1 Advection and dispersion

Overview/general description

The general processes of advection and dispersion are described in detail in Section 5.4.1. Although the barrier systems in BRT are very different from those in BMA, the mechanistic principles for the processes of advection and dispersion are the same. Therefore, repetition is avoided throughout this section by referencing the process description for BMA (Section 5.4.1) when appropriate.

The reactor pressure vessels in the vault are embedded in concrete grout and surrounded by macadam backfill. This implies that advective transport will be diverted mainly to the high conductive macadam. The extent to which this occurs is governed by the dissolved solute concentrations and the local groundwater flow (described separately in Sections 9.2.1 and 9.2.2). However, in the safety assessment the flow diversion effect has been neglected.

The purpose of the concrete floor and shotcrete lining of the vault is to provide mechanical support; the purpose of the concrete grout backfill is to maintain a chemically cementitious environment which thereby provides a chemical barrier. None of these concrete structures are envisaged to have any flow limiting properties and therefore no safety function for limited advective transport applies for the BRT barriers (see Section 3.2).

Dependencies between process and system component variables

The dependencies between process and system component variables are the same as for BMA described in Section 5.4.1.

Boundary conditions

The boundary conditions for the processes of advection and dispersion are the groundwater flow rates, the degree of water saturation and the groundwater chemical composition at the physical boundaries of the BRT vault and the waste form.

Model studies/experimental studies

See Section 5.4.1.

Natural analogues/observations in nature

See Section 5.4.1.

Time perspective

Advective transport of solutes by flowing groundwater will be relevant at all time scales in the BRT vault at SFR. A gradual loss of integrity of engineered structures, i.e. the concrete backfill, vault floor and shotcrete lining is presumed, in particular as a result of freeze damage during permafrost. These structures are however not envisaged as having a flow limiting function.

Handling in the safety assessment SR-PSU

Advection is cautiously assumed to be the predominant transport process for solutes in the BRT barriers and is included in modelling of radionuclide release. In the SR-PSU safety assessment, the water in the BRT vault is further assumed to be completely mixed, which implies infinite dispersion. With this assumption, the dispersion of solutes is regarded as instant, resulting in homogeneous concentrations throughout the entire aqueous phase. Advective transport is therefore important for calculating solute transport into and out from the vault only.

Gas-driven advection processes are considered in scenario calculations (cf. SKB 2008b).

Handling of uncertainties in SR-PSU

Uncertainties in mechanistic understanding: Advection and dispersion processes can be considered mature science and the conceptual uncertainties are small.

Model simplification uncertainties: The model simplifications are mainly related to the assignment of boundary conditions to reflect the changes in groundwater flow and chemical composition during different periods in time.

Input data and data uncertainties: Uncertainties in input data and data uncertainties are handled by assigning pessimistic values in modelling. The sensitivity to input data is checked by parameter variations and scenario analysis.

Adequacy of references supporting the handling in SR-PSU

The references are judged to be adequate and sufficient to support the handling in SR-PSU. All supporting references are either peer-reviewed articles or documents which have undergone factual review.

9.4.2 Diffusion

Overview/general description

The general process of diffusion is described in detail in Section 5.4.2. Although the barrier system in BRT is different from that in BMA, the mechanistic principles for the process of diffusion are the same. Therefore, repetition is avoided throughout this section by referencing the process description for BMA (Section 5.4.2) when appropriate.

The purpose of the concrete floor and shotcrete lining of the BRT vault is to provide mechanical support; the purpose of the concrete grout backfill is to maintain a chemically cementitious environment which thereby provides a chemical barrier. None of these concrete structures are considered to have any diffusion limiting properties and therefore no safety function for limited diffusive transport applies for the BRT barriers (see Section 3.2.2).

Handling in the safety assessment SR-PSU

Although the grouted volume of the BRT vaults offers a barrier to diffusion, in the SR-PSU the water in the BRT vault is assumed to be completely mixed. This assumption results in homogeneous concentrations throughout the entire aqueous phase. This pessimistic approach removes the need to address diffusion within the grout and concrete structures.

9.4.3 Sorption

Overview/general description

The sorption processes in cementitious and macadam components are the same as in the corresponding cementitious and crushed rock components of BMA, see Sections 5.4.3 and 5.4.4. This holds for the general descriptions of processes and relevant solids as well as for all individual radionuclides discussed there.

Dependencies between processes and barrier variables

Table 9-6 and Table 9-7 summarise how the process sorption influences and is influenced by all BRT variables and how these effects are handled. In addition, the handling of each influence in SR-PSU is indicated in the tables. Because of the significant differences in material properties, a separate process/variable table is given for the cementitious and macadam components of the barrier.

Table 9-6. Direct dependencies between the process ‘sorption’ and cementitious system component variables and a short note on the handling in SR-PSU.

Variable	Variable influence on process		Process influence on variable	
	Influence present? Yes/No	Description	Influence present? Yes/No	Description
Geometry	No.	Sorption is a molecular-level chemical process which is not directly influenced by macroscopic geometry.	No.	See material composition.
Temperature	Yes.	Temperature will have an effect on solids composition and on sorption processes.	No.	–
Hydrological variables	No.	No direct influence on sorption.	No but indirectly via material composition and geometry (Incorporation of major ions in HCP may cause mineral expansion and alter flowpaths).	See material composition.
Mechanical stresses	No.	–	No, but indirectly, see hydrological variables.	–
Material composition	Yes.	The composition of the material influences its sorption properties.	Yes.	Incorporation of major ions in HCP may cause mineral alteration.
Water composition	Yes.	Water composition can directly affect sorption and influence mineralogy.	Yes.	Incorporation of major ions and radionuclides in HCP influences dissolved concentration.
Gas variables	No direct influence.	CO ₂ can influence sorption indirectly through effects on water composition and mineralogy. H ₂ and CH ₄ can influence sorption indirectly through creating reducing conditions (water composition).	No direct influence.	Indirectly through influencing dissolved concentrations (especially Ca). No significant effects expected.

Table 9-7. Direct dependencies between the process ‘sorption’ and variables of the macadam component.

Variable	Variable influence on process		Process influence on variable	
	Influence present? Yes/No Description	Handling of influence How/If not – Why	Influence present? Yes/No Description	Handling of influence How/If not – Why
Geometry	No. Sorption is a molecular-level chemical process which is not directly influenced by macroscopic geometry.	–	No. The geometry of the crystalline minerals in macadam does not depend on sorbed ions.	–
Temperature	Yes. Temperature will have an effect on sorption processes.	No. Influence of temperature on sorption must be expected, but trend and magnitude are not clear. Where sorption data for relevant temperatures are available, they are taken into account in the selection of radionuclide K_d values.	No.	–
Hydrological variables	No. No direct influence on sorption.	–	No, see geometry.	–
Mechanical stresses	No.	–	No, see geometry.	–
Material composition	Yes. The composition of the material influences its sorption properties.	Included in selected K_d where relevant.	No. The bulk composition of the minerals in macadam does not depend on sorbed ions.	–
Water composition	Yes. Water composition can affect sorption.	Included in K_d where relevant.	Yes. Sorption could influence dissolved concentration.	Dissolved radionuclide concentration calculated via K_d . Process not considered for main constituents: effect regarded as negligible in comparison to mineral solubility.
Gas variables	No direct influence. CO_2 can influence sorption indirectly through aqueous speciation. H_2 and CH_4 can influence sorption indirectly through creating reducing conditions (water composition).	Included in K_d where relevant.	No direct influence. Indirectly through influencing dissolved concentrations. No significant effects expected.	–

Boundary conditions

Relevant boundary conditions are those that control the transport of solutes to and from the cementitious and macadam components; i.e. the boundary conditions of the processes advection and diffusion.

Model studies/experimental studies

The model and experimental studies for concrete/cement and crushed rock material discussed in Section 5.4.3 and Section 5.4.4 apply here as well.

Natural analogues/observations in nature

See Section 5.4.3 and Section 5.4.4.

Time perspective

See Section 5.4.3 and Section 5.4.4.

Handling in the safety assessment SR-PSU

Before saturation, the process is neglected. After saturation: radionuclide sorption is included in the modelling of radionuclide transport. Sorption is quantified using K_d values that are specific for each element (and oxidation state, where relevant) as well as for the respective conditions (material and water composition). Process uncertainties can generally be expressed through the use of bounding K_d values for both materials.

For the cement-based barrier materials, the exchange behaviour of major elements is included in the chemical degradation process (see Section 9.4.5). For the macadam component, the exchange behaviour of major elements is not addressed explicitly.

Handling of uncertainties in SR-PSU

Uncertainties are the same as in case of BMA, see Section 5.4.3 and Section 5.4.4.

9.4.4 Colloid stability, transport and filtering

Overview/general description

A general overview and description of colloid transport and filtering is provided in the corresponding section for the BMA barriers, i.e. Section 5.4.5, along with a discussion of colloid stability under repository conditions. Although the barrier systems in BRT are different from those in BMA, the mechanistic principles for the processes of colloid transport and filtering are the same.

Colloid stability is dependent on both pH and ionic strength, due to their influence on the surface charge and thickness of the electric double layer (see further Section 5.4.5). The pH and water composition in BRT will vary over time and are expected to be different from in the BMA, due to design differences. However, the large amounts of grout in and around the reactor pressure vessels in BRT will lead to highly alkaline, high ionic strength conditions for a significant period.

Colloid stability will be affected by the gradual reduction in pH and ionic strength as the cementitious material degrades. The effect may be complex as a lower pH generally reduces colloid stability, while a lower ionic strength increases colloid stability. However, in the cementitious system the initial drop in pH will be accompanied by an increased concentration of dissolved calcium, which is expected to decrease colloid stability. The ionic strength of the groundwater under temperate conditions, prior to the period of ingress of glacial melt water, is sufficiently high in order to maintain a low concentration of stable colloids.

Although the BRT rock vault is grouted to reduce the rate of reactor tank corrosion, the grout does not have a hydraulic performance requirement regarding the release of radionuclides. Therefore, the formation and stability of colloids have no influence on the barrier performance and are thus neglected in the safety assessment.

9.4.5 Concrete degradation

Section 5.4.6 introduces the key concepts behind concrete degradation including dissolution/precipitation/ recrystallisation processes. The concrete floor, concrete moulds, and grout in the BRT vault will be constructed using the same cement as in the BMA, thus the concrete will follow a similar chemical, mineralogical and mechanical evolution to that in the BMA (see Section 5.4.6). In the BRT vault, the reactor pressure vessels will be grouted with concrete on the inside and cast with concrete grout on the outside. This will contribute to highly alkaline, high ionic strength conditions. The porosity of the concrete grout backfill is higher than in structural concrete. The void between the cast concrete/concrete moulds and the shotcrete-lined rock walls is backfilled with macadam. There will also be a macadam backfill layer on top of the concrete embedded reactor pressure vessels.

The pH, ionic strength and reducing conditions of the waste leachate reaching the barrier are expected to be similar to those found in the BMA waste leachate. Since the BRT waste only consists of the steel reactor pressure vessels, the impact of various dissolved components in the BMA waste leachate do not apply here. Therefore the salt content is expected to be negligible in the BRT waste leachate.

Dependencies between process and system component variables

The BMA and BRT are similar in terms of dissolution/precipitation/recrystallisation processes, and the major controls over these. The main relevant differences are the different geometries and porosities of the cementitious materials used. Therefore, the influences described for BMA in Table 5-12 and the associated justifications are applicable also to the BRT barriers.

Boundary conditions

The boundaries of this analysis are the barriers themselves with exchange of mass from the reactor pressure vessels, plugs in access tunnels and the surrounding geosphere considered.

Model studies/experimental studies

See Section 5.4.6.

Natural analogues/observations in nature

See Section 5.4.6.

Time perspective

See Section 5.4.6.

Handling in the safety assessment SR-PSU

Concrete degradation involving mechanical processes and dissolution/precipitation/recrystallisation processes are central considerations in the evaluation of the physical and chemical integrity of the barriers and are included in the assessment for the BRT.

Handling of uncertainties in SR-PSU

Uncertainties in mechanistic understanding: Uncertainties in mechanistic understanding of dissolution/precipitation/recrystallisation processes are generic and not specific to the BRT. They are therefore handled in the same way as for the BMA (Section 5.4.6).

Model simplification uncertainties: Dissolution/precipitation/recrystallisation processes are assessed based on the same simplifications as for the BMA (Section 5.4.6).

Input data and data uncertainties: The input data are affected by the same type of limitations as discussed for the BMA (Section 5.4.6).

9.4.6 Aqueous speciation and reactions

Overview/general description

Section 5.4.7 introduces the key concepts behind aqueous speciation and reactions, and summarises temporal changes to the groundwater in the vicinity of SFR. The purpose of the concrete floor and shotcrete lining of the BRT vault is to provide mechanical support; the purpose of the concrete grout backfill is mainly to maintain a chemically cementitious environment which thereby provides a chemical barrier. The vault design is therefore different from the BMA and the safety function is the limited quantity of waste and the controlled release of radionuclides through a low corrosion rate. Large amounts of grout will be used both inside and around the reactor pressure vessels to limit their corrosion (**Initial state report**). This will provide a buffering capacity to maintain a high pH over an extended period of time.

The inputs and mixing of groundwater, waste leachate and concrete leachate over time will define the aqueous speciation and the reactions that occur in the vault. The waste in BRT is composed of steel and the corrosion of this will consume oxygen and create highly reducing conditions and iron corrosion products, as described in the **Waste process report** and Section 5.4.9. Concrete moulds used for casting concrete around the reactor pressure vessels contain reinforcement bars that will contribute to oxygen consumption and depletion, and subsequent formation of hydrogen during corrosion.

As described in Section 5.4.7, the groundwater composition will change over time, affecting the aqueous speciation and reactions in the vault. If shoreline displacement occurs as described in SKB (2008b), the groundwater will consist of freshwater sometime after 1,000 years after closure. The lower ionic strength and greater bicarbonate concentration may cause dissolution or precipitation reactions. Also, humic acids may be present at higher concentrations in the new groundwater, and the lower salinity will enhance the solubility of humic-like molecules that form through organic degradation processes in the waste. Following glaciation, the water chemistry will change again to glacial melt water and this may affect aqueous speciation and reactions further.

Dependencies between process and system component variables

Table 9-8 shows how the processes aqueous speciation and reactions influence, and is influenced by, all defined BRT system variables. In addition, the handling of each influence in SR-PSU is indicated in the table and discussed more thoroughly in the text below. The system variables and their definition within this report are presented in Section 4.3.5.

Influence by geometry

No direct influence identified.

The geometry of the barriers is defined by the space between the reactor pressure vessels and the rock vault. Both the exposed surface area and the porosity of the concrete components will affect exchange between the concrete porewater and the groundwater via dissolution/precipitation reactions and water composition. The concrete geometry will therefore indirectly affect the evolution of the pH and ionic strength of the barrier porewater over time.

Aqueous speciation will also be affected indirectly by the surface area of the solid material in the barrier (e.g. the concrete floor, shotcrete lined walls, concrete moulds and cast concrete, plugs, any precipitated phases) through sorption (Section 9.4.3).

Influence on geometry

No direct influence identified.

Aqueous speciation determines sorption, precipitation and dissolution reactions and these reactions affect the pore volume of the vault. This indirect effect is of negligible importance in the BRT barriers.

Influence by temperature

Yes, there is a direct influence.

Temperature is a fundamental factor in chemical reaction rates and the position of chemical equilibria and is addressed in the geochemical modelling.

Influence on temperature

Yes, there is a direct influence but it is not significant.

Aqueous exothermic or endothermic reactions are judged to be of minor importance to the temperature in the repository.

Table 9-8. Dependencies between the processes aqueous speciation and reactions and the BRT system component variables.

Variable	Variable influence on process		Process influence on variable	
	Influence present? Yes/No Description	Handling of influence How/If not – Why	Influence present? Yes/No Description	Handling of influence How/If not – Why
Geometry	No, although the surface area of the void boundaries and precipitated phases will influence aqueous speciation indirectly via water composition.	Not relevant.	No, although aqueous speciation has an indirect influence via water composition and reactions such as sorption (Section 9.4.3), precipitation and dissolution, which in turn affect geometry.	Not relevant.
Temperature	Yes, temperature affects reaction rates and thermodynamic equilibria.	Repository temperature is an input to the geochemical modelling. Variations in temperature are assumed to be negligible, except during climate scenarios.	Yes, if endo- or exothermic reactions take place.	No, no major endo- or exothermic reactions anticipated.
Hydrological variables	Yes, pressure affects aqueous speciation. Indirect effects result from the aggregation state, the magnitude, direction and distribution of water flow, and the amount of water, via water composition.	Included in the geochemical modelling.	No, although, aqueous speciation can affect the aggregation state indirectly via water composition.	Not relevant.
Mechanical stresses	No, although pressure can affect the aqueous speciation indirectly via the equilibrium position of reactions that involve a phase change.	Not relevant.	No, although aqueous speciation may influence reactions that involve volume expansion, and so may influence mechanical pressure indirectly.	Not relevant.
Material composition	No, although concrete components will affect the aqueous speciation and reactions indirectly, via dissolution and water composition.	Not relevant.	No, although aqueous speciation may affect material composition indirectly via water composition and dissolution, precipitation and sorption (Section 9.4.3) processes.	Not relevant.
Water composition	Yes, water composition controls aqueous speciation and reactions. The indirect impact of gases (carbon dioxide, hydrogen, methane) is considered.	Included in the geochemical modelling.	Yes, aqueous speciation and reactions controls water composition including particulate phases.	Included in the geochemical modelling.
Gas variables	No, although gas solute-exchange could impact aqueous speciation indirectly, via water composition.	Not relevant.	No, although aqueous speciation and reactions could generate or use gases (also relates to microbial processes, see Section 9.4.7), i.e. have an indirect effect via water composition.	Not relevant.

Influence by hydrological variables

Yes, there is a direct influence.

Pressure has a direct, although small, effect on aqueous speciation. This is neglected in the geochemical modelling for SR-PSU.

Aqueous speciation is also affected indirectly by a number of hydrological variables in the BRT via water composition. The aggregation state is important due to the freezing out of dissolved substances as ice crystals form (e.g. Belzile et al. 2002). Also, the magnitude, direction and distribution of water flow are important for controlling both the composition of the water entering the vault and the rate and extent of water renewal, which affects the temporal development of the aqueous conditions.

Influence on hydrological variables

No direct influence identified.

There is an indirect effect via water composition since dissolved components such as salt affect the aggregation state through changes to the freezing point of water.

Indirect effects on hydrological variables can also occur via dissolution, precipitation and recrystallisation reactions, which can affect the volume of water, the degree of saturation and thus the water pressure. However, these are considered to be of low importance in the BRT vault.

Influence by mechanical stresses

No direct influence identified.

Pressure change resulting from mechanical stress has an influence on the equilibrium position of reactions involving changes in the volume of the solid phases in the system, and therefore affects aqueous speciation. This, however, is an indirect effect with negligible influence on the function of the BRT barriers. Mechanical stress may also cause fracturing of the concrete components, and enhance dissolution. This is considered to have a negligible impact on the aqueous speciation and reactions.

Influence on mechanical stresses

No direct influence identified.

Precipitation and recrystallisation reactions can occur, causing volume expansion of the solid phases in the BRT barriers, which may increase the mechanical pressure. This, however, is an indirect influence with negligible effect on the function of the BRT barriers.

Influence by material composition

No direct influence identified.

The concrete components of the BRT vault will influence aqueous speciation and reactions indirectly via changes in water composition, particularly through pH and ionic strength alteration.

Influence on material composition

No direct influence identified.

The aqueous speciation will define the precipitation reactions that occur indirectly, via water composition, and will therefore influence the amount, composition and surface characteristics of the solid phases within the vault. However, this is judged negligible for the BRT barriers.

Influence by water composition

Yes, there is a direct influence.

The water composition defines the aqueous speciation. More specifically the redox conditions, pH, ionic strength, concentration of dissolved species, type and amount of colloids and/or particles and the amount and composition of dissolved gas define the aqueous phase. It also defines the speciation of each element in the water under the prevailing temperature and pressure conditions.

Influence on water composition

Yes, there is a direct influence.

The aqueous speciation controls the water composition and the solubility of the species within the system. The chemical species define the redox potential, pH, ionic strength, concentration of dissolved species, amount of colloids and particles and the amount and composition of dissolved gas. The aqueous speciation therefore affects the salinity, density and viscosity of the water.

Influence by gas variables

No direct influence identified.

The amount, composition, volume, and pressure degree of saturation of gases will influence the aqueous speciation indirectly via water composition, as these affect the degree of dissolution in the aqueous phase.

Influence on gas variables

No direct influence identified.

Aqueous speciation will affect the amount, composition, volume and pressure degree of saturation of gases, via water composition, as the saturation limit of dissolved gas is affected by pH and aqueous speciation. An example of this is the solubility of CO₂ in water, which is reduced at lower pH because H⁺ ions push the carbonate equilibria towards H₂CO₃, thus limiting further dissolution of CO₂.

Boundary conditions

The boundaries of this analysis are the barriers themselves with exchange of mass and heat from the reactor pressure vessels and the surrounding geosphere considered.

Model studies/experimental studies

See Section 5.4.7.

Natural analogues/observations in nature

See Section 5.4.7.

Time perspective

The aqueous speciation and reactions within the BRT barriers are dependent on the external groundwater conditions and the input from the degrading concrete grout and reactor pressure vessels over time.

Handling in the safety assessment SR-PSU

Aqueous speciation and reactions are central considerations in the geochemical model used for BRT.

Handling of uncertainties in SR-PSU

Uncertainties in mechanistic understanding: Uncertainties in mechanistic understanding of aqueous speciation and reactions are generic and not specific to the BRT vault. They are therefore handled in the same way as for the BMA (Section 5.4.7).

Model simplification uncertainties: The major simplifications in the aqueous chemistry and reactions of BRT are that the vault is treated as a fully mixed system. The model simplification uncertainties described for the BMA (Section 5.4.7) are also relevant, i.e. the selection and simplification of parameters to define the system and the assumption of thermodynamic equilibrium.

Input data and data uncertainties: The waste form is relatively simple in BRT, compared with the other vaults. The greatest uncertainty in the data is associated with the rate of grout degradation and therefore the rate of steel degradation. The groundwater chemistry is dependent on whether shoreline displacement occurs, thus this requires careful assessment.

Adequacy of references supporting the handling in SR-PSU

The references are judged to be adequate and sufficient to support the handling in SR-PSU. All supporting references are either peer-reviewed articles or documents which have undergone factual review.

9.4.7 Microbial processes

Overview/general description

Biological processes involve many reactions that are either very slow or do not occur in sterile lifeless chemical systems, e.g. the reduction of sulphate to sulphide (Goldstein and Aizenshtat 1994, Cross et al. 2004). This is because life has the ability to over-run activation energy barriers and other energetic constraints that prevent spontaneous chemical reactions. Life is possible from -20°C up to above 113°C , where in general all life processes stop. Life is also possible within a large pH range, from pH 1 up to above pH 12 (Yumoto 2007, Pedersen 2004b). In BRT, pH is likely to be maintained at hyperalkaline conditions throughout the lifetime of the repository. Although some microbes are able to survive at pH above 12, most alkaliphilic bacteria have their optimal growth pH in the range 8–10, meaning that their activity subsides outside this range (Yumoto 2007).

For more details see Section 5.4.8.

Fermentation

Fermenting microorganisms thrive in anaerobic systems containing large amounts of organic material and is not expected in BRT.

Respiration

A general microbial process is respiration, which must proceed in all active microorganisms, except for those using a fermentative metabolism where the electron donor and acceptor is the same molecule. Respiration mainly influences the barrier variables material composition, water composition, gas composition.

Oxygen is a very potent electron acceptor and, as a result, will be rapidly consumed during microbial activity. When oxygen has been consumed nitrate will be the preferred electron acceptor, then Mn(IV), Fe(III), sulphate, sulphur and finally carbon dioxide are reduced.

(For more details see the Waste process report).

Methylation and alkylation

See the **Waste process report**.

Biofilm formation

Microbes that are attached to a surface create a micro environment in order to protect the cells from drying and other extreme conditions such as high pH. In addition they often excrete acidifying compounds and chelators that could mobilise some components from the surface that they are attached to. Some fungus like microbes produce hyphae that affect the surfaces mechanically. Many microorganisms attach and grow on surfaces of all types in aquatic systems. Attachment to a surface, such as a barrier wall, is commonly looked upon as a more favourable state compared to being unattached at least in a system with flowing water. Microbes in a biofilm are as a rule more active than unattached cells, which in turn could result in faster degradation of the barrier.

Typically, microbial biofilms form where gradients of nutrients and sources of energy are present. The solid itself may constitute the nutrient and energy source due to added organic components and possibly waste components diffusing out from the wastes. Biological iron oxides (BIOS) that produce dense mats of rusty material with iron- manganese and sulphur-oxidising bacteria (Anderson et al. 2006) on positions in SFR where groundwater is percolating over walls and tunnel floors will form during the aerobic operational phase. These are not expected to form on the concrete barrier walls due to the hyperalkaline pH in the porewater.

Upon closure, conditions will become anaerobic within a short time and the production of these mats will stop and degradation of them will start. Once the repository is filled with water the pH conditions is expected to become hyperalkaline. Pedersen (2004b) have shown that microbes are able to attach to surfaces at hyperalkaline conditions. However, comparing Fennoscandian microbial groundwater flora with the natural hyperalkaline analogue in Maqarin the number of attached cells was two orders of magnitude lower under hyperalkaline conditions. This could be interpreted as the attaching microbes were inactive and only attached because of surface interaction forces (Pedersen 2004b).

Anabolic processes

See the **Waste process report**.

Dependencies between microbial processes and BRT concrete variables

For more details see Section 5.4.8.

Dependencies between microbial processes and BRT vault and backfill variables

For more details see Section 5.4.8.

Boundary conditions

If there is access to water, electron donors (for energy), electron acceptors (for respiration) and nutrients, microbial growth is possible. The pH gradients will control microbial growth and diversity at the surface of the concrete barriers. In the backfill, too, microbial growth is possible, and may be significant in the presence of an advective flow. The effect will, however, be low under stagnant hydraulic conditions. If there is not a flow that will supply the cells with nutrients and keep the fermentation products at a healthy level, the microbes will not only be poisoned by fermentation products such as ethanol, they will eventually starve as they will run out of food. This is exactly what happens in a batch culture in the laboratory. Acidic exudates excreted from bacteria will deteriorate cement and concrete.

Microbial growth is possible on concrete structures and may be significant in the presence of an advective flow. Because of the hyperalkaline pH and the fact that the waste in BRT does not contain any organics, the microbial activity is expected to be extremely low, if occurring at all. The corrosion of waste will also be low because of the hyperalkaline conditions set by the concrete barriers. As a result there will be limited or no access to H₂ which is a favoured energy source for e.g. SRB and, in absence of sulphate, for methanogens. Fermentation will neither take place in the waste nor in the barriers due to the lack of organic substances.

The magnitude, direction and distribution of groundwater flow over BMA barriers will influence the transport of microbes and, much more importantly, the transport of e-acceptors to, and degradation products from, microbes dwelling in BMA barrier systems (Pedersen 2001). Oxygen is a very potent e-acceptor and in situations where oxygen gradients develop over the barriers, sulphuric and nitric acid production from sulphide and ammonium, respectively, is possible.

Model studies/experimental studies

For more details see Section 5.4.8.

Natural analogues/observations in nature

For more details see Section 5.4.8.

Time perspective

Microbial processes will be on-going throughout the lifetime of the repository. The dominating process at different time interval may differ. During the open phase, and other time windows when oxygen is present, inorganic acid production can be significant. The production of biofilms and BIOS in the vault and backfill can be large, but is expected to cease after closure and water saturation. The process of carbon dioxide production and carbonation of concrete can proceed most of the repository life time, as long as there is organic material available for microbial processes.

Handling in the safety assessment SR-PSU

The process can be neglected during the period with high pH.

Handling of uncertainties in SR-PSU

Uncertainties in mechanistic understanding: The basic scientific mechanisms governing the described microbial processes are well understood and their relevance for BRT barriers and extent in BRT barriers are assumed to be negligible.

Model simplification uncertainties

The modelling performed by Cronstrand (2007) does not take microbial processes into account, which introduces uncertainties to the models as Gorbunova and Barinov (2011) showed that microbes are able to grow in the pores in concrete. After 100,000 years, pH is lower than 12.5 in the whole concrete barrier even if microbial processes are excluded.

Input data and data uncertainty

Microbial processes are not taken into account as there are no data to model.

9.4.8 Metal corrosion

Metal is present in the reinforced concrete floor and structures (fundaments and moulds) for reactor pressure vessels, and in the rock bolts in the shotcrete-lined rock walls. The metal used for both reinforcement and rock bolts is carbon steel. The concrete grout inside and surrounding the reactor pressure vessels, and the macadam backfill in the BRT do not contain any metal.

The major source of metals in the BRT vault is the reactor pressure vessels made of iron and steel. Corrosion of metallic waste and metals in waste packaging is described in the **Waste process report** (Section 2.5.10 Metal corrosion).

In BRT, metal corrosion of reinforcement bars is of importance for predictions of degradation of concrete structures as well as for estimates of oxygen depletion and for rates of subsequent gas formation.

Overview/general description.

A general description of steel corrosion related to reinforced concrete in the BMA vault is given in Section 5.4.9, and is not repeated here.

Dependencies between process and system component variables

Metal corrosion occurs in a similar way in the BRT and BMA barriers, although the geometry and configuration of the barrier system components differ. The influence of the specified set of physical variables on metal corrosion and how this process influences the variables are therefore judged to be the same as for BMA. These dependencies are described in detail in Section 5.4.9, and are not described further here.

Boundary conditions

See Section 5.4.9.

Model studies/experimental studies

See Section 5.4.9.

Natural analogues/observations in nature

See Section 5.4.9.

Time perspective

See Section 5.4.9.

Handling in the safety assessment SR-PSU

The corrosion of metal reinforcement bars in concrete structures, rock reinforcements and rock bolts in BRT is considered in the safety assessment in terms of:

- Fracturing in concrete.
- Evolution of redox conditions.
- Contribution to gas formation in the vault.

9.4.9 Gas formation

Gas formation is important within the BRT barriers (i.e. the concrete floor, concrete structures and grout) as it will increase the pressure of the system once the saturation limit of the water phase is reached, i.e. when no further gas can be dissolved. Elevated pressure could lead to transport of gas (Section 9.2.3).

The reactor pressure vessels are judged to be the main source for gas formation in BRT. The different chemical processes causing gas formation in the reactor pressure vessels are described in the **Waste process report** (Section 2.5.11 Gas formation). Hydrogen evolving corrosion of the reinforcement bars in the concrete moulds will contribute to the total amount of gas formed in the BRT. Less prominent potential sources of gas formation in the vault are: microbial degradation of organic material in the macadam, or organic matter that migrates into the vault from the geosphere; and radiolysis of water.

Overview/general description

General descriptions of hydrogen evolving metal corrosion and gas formation are given in Sections 5.4.9 and 5.4.10, respectively, while the handling of metal corrosion in the BRT barriers is described in Section 9.4.8. Section 5.4.8 describes microbial processes in the BMA barriers, including gas formation.

Dependencies between process and system component variables

Gas formation occurs through similar mechanisms in the BRT and BMA barriers, although the geometry and configuration of the barrier system components differ. The influence of the specified set of physical variables on gas formation and how this process influences the variables are therefore judged to be the same as for BMA. These dependencies are described in detail in Section 5.4.10, and are not described further here.

Boundary conditions

See Section 5.4.10.

Model studies/experimental studies

See Section 5.4.10.

Natural analogues/observations in nature

See Section 5.4.10.

Time perspective

See Section 5.4.10.

Handling in the safety assessment SR-PSU

Hydrogen evolving corrosion of reinforcement bars in concrete structures, rock reinforcement and rock bolts in the BRT will be included in analyses of fracturing in concrete, build-up of gas phase leading to pressure build-up, and determination of redox conditions. Hydrogen evolving corrosion is assumed to start instantaneously.

9.5 Radionuclide transport

9.5.1 Speciation of radionuclides

Radionuclide speciation is a fundamental process whose general features are independent of the specific environment. A general process description is given in the corresponding chapter for BMA, see Section 5.5.1. Moreover, the chemical environments in the cementitious and macadam components can be expected to be the same as in the corresponding (cementitious and crushed rock) components of BMA, and therefore the same dependencies between processes and barrier variables are anticipated.

Table 9-9. Dependencies between the process ‘speciation of radionuclides’ and system component variables and a short note on the handling in SR-PSU.

Variable	Variable influence on process		Process influence on variable	
	Influence present? Yes/No Description	Handling of influence How/If not – Why	Influence present? Yes/No Description	Handling of influence How/If not – Why
Geometry	No. Speciation is a molecular-level chemical process which is not influenced by geometry.	–	No.	–
Temperature	Yes. Temperature will effect speciation.	Effect of temperature on equilibria is considered in speciation models using thermodynamic data or approximations.	No.	–
Hydrological variables	No (no direct influence on speciation).	–	No.	–
Mechanical stresses	No.	–	No.	–
Material composition	Indirectly through porewater composition.	See water composition.	No. Radionuclides are only trace constituents.	–
Water composition	Yes. Water composition directly affects speciation.	Water composition considered in speciation modelling.	Yes. Speciation effects the chemical form of the dissolved radionuclides and in that sense water composition. Radionuclide concentrations are at trace levels and do not influence bulk water composition.	Included in speciation modelling.
Gas variables	Indirectly by influencing water composition.	See water composition.	No. Radionuclides are only trace constituents and do not effect the bulk gas composition, their speciation does not influence bulk gas composition.	Not considered.

Handling in the safety assessment SR-PSU

Radionuclide speciation is only relevant after saturation and in case of a release of radionuclides. The speciation of radionuclides is calculated based on thermodynamic data (i.e. assuming equilibrium) and may be used to define solubility limits where relevant. For the SR-PSU safety assessment, no solubility limits are considered, however.

Radionuclide speciation is also used to assess their sorption behaviour. In case of cement-based materials there is a high degree of similarity between expected conditions and those in relevant laboratory experiments. For sorption on crushed rock, an approach similar to bentonite can be followed, where relevant.

9.5.2 Transport of radionuclides in the water phase

The radionuclide transport modelling for BRT follows the same mathematical description as the modelling of BMA (See corresponding process description for BMA (Section 5.5.2).

Advection is explicitly included in the radionuclide transport modelling. However, the calculation of water fluxes are performed in a calculation step separated from the radionuclide transport calculations.

No significant transport resistance in the concrete barriers are taken into account, but for the BRT repository the steel in the reactor pressure vessels acts as a barrier for induced radionuclides and this effect is taken into account in the modelling. See the **Waste process report** for details.

Dependencies between process and system component variables

Table 9-10 shows how transport of radionuclides in the water phase in the BRT system is influenced by the specified set of physical variables and how the process influences the variables.

Boundary conditions

The inner boundary for the radionuclide transport processes is the concentration of nuclides in the interior of the BRT repositories. The outer boundary is the concentration in the rock outside the repository.

Table 9-10. Direct dependencies between “Transport of radionuclides in the water phase” and system component variables and a short note on the handling in SR-PSU.

Variable	Variable influence on process		Process influence on variable	
	Influence present? Yes/No	Description Handling of influence How/If not – Why	Influence present? Yes/No	Description Handling of influence How/If not – Why
Geometry	Yes.	Gives the volumes and areas available for transport.	Yes.	Geometry variables are included in RN-transport model.
Temperature	No.	Effects are negligible.	No.	–
Hydrological variables	Yes.	Water fluxes are highly significant for advective transport of RN.	Yes.	Detailed flow parameters are included in the RN model.
Mechanical stresses	No.	–	No.	–
Material composition	Yes.	Sorption properties are highly dependent on material composition.	Yes.	Material specific K_d values are included in the RN model.
Water composition	Yes.	Sorption properties are dependent on water composition.	Yes.	Included in K_d data.
Gas variables	No.	–	No.	–

Model studies/experimental studies

Not applicable.

Natural analogues/observations in nature

Not applicable.

Time perspective

Transport of radionuclides in the water phase will be relevant at all time scales in SFR.

Handling in the safety assessment SR-PSU

See the corresponding section for BMA.

Handling of uncertainties in SR-PSU

See the corresponding section for BMA.

Adequacy of references supporting the handling in SR-PSU

See the corresponding section for BMA.

9.5.3 Transport of radionuclides in the gas phase

See corresponding process description for BMA (Section 5.5.3).

10 Plugs and other closure components

10.1 Thermal processes

10.1.1 Heat transport

The heat transport process is described in the corresponding section for the BMA repository (Section 5.1.1). This description also applies here.

Dependencies between process and system component variables

Table 10-1 shows how the process influences, and is influenced by, all system variables.

Boundary conditions

See Section 5.1.1.

Model studies/experimental studies

See Section 5.1.1.

Table 10-1. Direct dependencies between the process “Heat transport” and the defined system variables and a short note on the handling in SR-PSU.

Variable	Variable influence on process		Process influence on variable	
	Influence present? Yes/No	Description Handling of influence How/If not – Why	Influence present? Yes/No	Description Handling of influence How/If not – Why
Geometry	Yes, the constitution of the system determine how heat flows.	The process is not explicitly handled. See Section 5.1.1.	No.	
Temperature	Yes. Temperature differences is an requirement for the process.	The process is not explicitly handled. See Section 5.1.1.	Yes. Heat transport tends to even out temperature differences.	The process is not explicitly handled. See Section 5.1.1.
Hydrological variables	Yes. Water flow may transport heat. Heat capacities may change with saturation state and aggregation state.	The process is not explicitly handled. See Section 5.1.1.	Yes, through e.g. convection. The influence is however negligible because temperature differences are small.	The process is not explicitly handled. See Section 5.1.1.
Mechanical stresses	Yes, in principle as e.g. heat capacities may depend on stress state. The effect is however negligible.	The process is not explicitly handled. See Section 5.1.1.	Yes. Due to thermal expansion/contraction.	The process is not explicitly handled. See Section 5.1.1.
Material composition	Yes. Different materials have different thermal conductivities, specific heats etc.	The process is not explicitly handled. See Section 5.1.1.	No.	
Water composition	Yes in principle as e.g. heat capacities may depend on composition. The effect is however negligible.	The process is not explicitly handled. See Section 5.1.1.	No.	
Gas variables	Yes. Gas flow may transport heat.	The process is not explicitly handled. See Section 5.1.1.	Yes, but relevant only during the operational phase when the repository is not water saturated.	The process is not explicitly handled. See Section 5.1.1.

Natural analogues/observations in nature

See Section 5.1.1.

Time perspective

See Section 5.1.1.

Handling in the safety assessment SR-PSU

See Section 5.1.1.

Handling of uncertainties in SR-PSU

See Section 5.1.1.

References

See Section 5.1.1.

10.1.2 Phase changes/freezing

Overview/general description

The description made for the BMA repository vault (Section 5.1.2) applies also here. For a general description of bentonite mechanisms, see Section 7.1.2.

Dependencies between process and system component variables

Table 10-2 shows how the process influences, and is influenced by, all system variables.

Boundary conditions

See Sections 5.1.2 and 7.1.2.

Model studies/experimental studies

See Sections 5.1.2 and 7.1.2.

Natural analogues/observations in nature

See Sections 5.1.2 and 7.1.2.

Time perspective

See Sections 5.1.2 and 7.1.2.

Handling in the safety assessment SR-PSU

See Sections 5.1.2 and 7.1.2.

Handling of uncertainties in SR-PSU

See Sections 5.1.2 and 7.1.2.

Table 10-2. Direct dependencies between the process “Freezing” and the defined system variables and a short note on the handling in SR-PSU.

Variable	Variable influence on process		Process influence on variable	
	Influence present? Yes/No Description	Handling of influence How/If not – Why	Influence present? Yes/No Description	Handling of influence How/If not – Why
Geometry	Yes. Freezing point is influenced by confinement geometry if it is small (sub microns). Frost susceptibility depends on pore geometry.	Freezing points (or temperature intervals) are estimated for each component material.	Yes. Pore geometries may be different after freezing. Fractures may have been created or widened. Cycles of freezing/thawing may cause particle sorting.	Altered hydraulic conductivity after permafrost period. Ice lens formation in bentonite will be quantified.
Temperature	Yes. The freezing point is a certain temperature.	Freezing points (or temperature intervals) are estimated.	Yes. Freezing releases energy. Thawing consumes energy.	Neglected.
Hydrological variables	Yes. Water pressure have a minor influence on freezing point.	Insignificant, unless very high pressures.	Yes. Freezing may cause pressure increase and affect water flow. Freezing may also reduce conductivity (a completely frozen system does not flow).	The barrier function of concrete is considered lost after a freezing/thawing cycle. Possible changes in hydraulic conductivity of the bentonite is estimated.
Mechanical stresses	Yes. Pressure influences freezing point.	Insignificant, unless very high pressures involved.	Yes. Freezing and frost heave may induce stresses and strains.	Altered hydraulic conductivity after permafrost period. Effect on host rock is estimated. Ice lens formation in bentonite will be quantified.
Material composition	Yes. Freezing point is influenced by surface properties.	Freezing points (or temperature intervals) are estimated.	No.	
Water composition	Yes. Freezing point is influenced by type and concentration of solutes.	Estimated from water chemistry.	Yes. Freezing may change composition of remaining unfrozen water.	Neglected, because possible freezing is slow in comparison to diffusive and advective mass transfer.
Gas variables	No. Indirectly through dissolved gases.	Insignificant unless gas pressures are high. Handled via water composition.	No.	

10.2 Hydraulic processes

10.2.1 Water uptake and transport during unsaturated conditions

According to the closure plan of SFR (SKBdoc 1358612) there are several different plug types and other closure components planned for SFR. There are four different closure types, which in turn are made up of different components:

1. Closure of rock caverns.
2. Closure of the silo.
3. Closure of ramps and tunnels.
4. Closure of shafts.

Those closure types will not be treated separately and in detail. Instead the included material components will be analysed. The following parts are included:

- Hydraulically tight sections of bentonite blocks and pellets.
- Concrete plugs.
- Transition material of 30/70 bentonite crushed rock.
- Backfill of crushed rock.

Overview/general description

The water saturation process of the different parts is very different. The crushed rock is filled with water in the same rate as the water inflow and the backfill will be water saturated from the bottom. The saturation rate is controlled by the inflow rate. The transition material has a low hydraulic conductivity that delays the water saturation, which is estimated to take 1–10 years. The concrete plugs are mainly wetted from the contact surface with the backfill. The hydraulically tight sections of bentonite with high density have a very low hydraulic conductivity that delays the saturation. Depending on the length of the section and the available water supply from the rock or neighboring filling material, the time to full saturation is expected to take from ten years up to several hundred years.

The process “water uptake and transport during unsaturated conditions” is in detail described in Section 5.2.1 and in Section 7.2.1 and also in the buffer, backfill and closure process report for SR-Site (SKB 2010a).

Dependencies between process and system component variables

Table 10-3 summarises how the process influences and is influenced by all plug and closure variables. In addition, the handling of each influence in SR-PSU is indicated in the table.

Boundary conditions

The plugs and other closure components have the rock, an adjacent closure component and in some case the backfill around the waste as boundary.

Table 10-3. Direct dependencies between the process “Water uptake and transport under unsaturated conditions” in the plugs and closures and the defined variables and a short note on the handling in SR-PSU.

Variable	Variable influence on process		Process influence on variable	
	Influence present? Yes/No	Handling of influence How/If not – Why	Influence present? Yes/No	Handling of influence How/If not – Why
Geometry	Yes.	Included in the model.	No.	–
Temperature	No, but indirectly through water viscosity.	Negligible.	No.	–
Hydrological variables	Yes, basic variables.	Included in the model.	Yes.	Included in the model.
Mechanical stresses	Yes.	Included in the model.	Yes.	Yes, included in the model.
Material composition	Yes.	Influences the parameters in the model.	No.	–
Water composition	Yes.	Influences some parameter values in the model.	No.	–
Gas variables	Yes, via gas pressure and degree of saturation.	Included in the model.	Yes, amount of gas and degree of saturation.	Included in the model.

Model studies/experimental studies

The wetting of bentonite in the tight sections with blocks and pellets is very similar to the wetting of the deposition tunnels described in SR-Site. A large number of tests and modelling exercises have been performed for that material (see e.g. Åkesson et al. 2010). The transition material (30/70 mixture) has also been studied in earlier projects for SR-Can since that was the reference backfill material (see e.g. Börgesson and Hernelind 1998 and Börgesson et al. 2006).

There are also numerous examples of wetting of concrete structures in engineering practice.

Natural analogues/observations in nature

See Section 5.2.1.

Time perspective

The timescale on which the process occurs is very much dependant on the material and the supply of water from neighboring parts. The backfill of crushed rock will at first be water saturated (years or less) and the tight sections with high density bentonite will be the last to be saturated (up to several hundred years).

Handling in the safety assessment SR-PSU

The water saturation of some parts of the plugs and closure components may be delayed and take several hundreds of years. This may not affect the safety assessment but it is anyway important to have a good description and understanding of the evolution.

The saturation evolution will be modelled for some wetting scenarios.

Timescales: The time scale will be illustrated by the modelling results. The uncertainties of many parameters and the complicated geometry make the modelling difficult but the time to full saturation will be framed.

Boundary conditions: The rock will be included in the model and some major mapped fractures included, but the complicated geometry may require simplifications such as having the rock as a boundary condition. If there is a highly permeable disturbed zone in the rock surface this will simplify the model. Different boundary conditions will be used to reflect the influence.

Handling of variables influencing this process: All the influencing variables in the table, except temperature, will be included in the model.

Handling of variables influenced by this process: All the influenced variables will be included in the model. The degree of saturation as a function of time and space will be modelled.

Handling of uncertainties in SR-PSU

The uncertainties are mainly related to the rock properties and the existence of cracks in the concrete.

Uncertainties in mechanistic understanding: The general understanding of unsaturated flow in clay fillings and concrete are rather good. The main uncertainties are the properties of the cracks in the concrete.

Model simplification uncertainties: The water flow in the concrete will probably be simplified to assume that there are several cracks that let water flow freely through them.

Input data and data uncertainties: The properties of the concrete are the most uncertain.

10.2.2 Water transport under saturated conditions

The plugs are designed to have such a low hydraulic conductivity that the water flow is directed through the central tunnels instead of through the rock caverns. Proper function of the plugs is vital for the safety. The hydraulic seal function is required during the entire life time of the repository. An overview of the different plugs is given in the beginning of Section 10.2.1.

Overview/general description

After full water saturation of all parts of the plugs and the other closure components and establishment of the natural hydrostatic conditions, very little water will flow past the plugs due to the low gradient and the low hydraulic conductivity of the bentonite sections. Just as for unsaturated conditions the detailed water flow processes in the plugs are complicated due to the complicated geometry and differences in hydraulic properties of the components. There will mainly be matrix flow in the bentonite barriers while the flow in concrete plugs is expected to be concentrated to the macro cracks.

After long time the cement is expected to be degraded and the hydraulic function of the cement and concrete changed. The water tightness of the plugs will thus entirely rely on the tightness of the bentonite sections.

The degradation of cement and subsequent degradation of the concrete will destroy the mechanical support of the concrete plugs. This will lead to a compression of the remaining ballast material in the plug and eventually a displacement of the plug, which in turn will cause a swelling of the bentonite section. This will reduce the swelling pressure and increase the hydraulic conductivity, but the result is not expected to change the sealing function considerably. See also Section 10.3.1 Mechanical processes.

Water flow in saturated porous material is a special case of unsaturated flow. The descriptions of the basic flow processes given in Sections 5.2.2 and 7.2.2 are also valid for the plugs.

The hydraulic conductivity of the mixture of 30% bentonite and 70% sand in the transition zone may vary between 10^{-9} and 10^{-11} m/s depending on the dry density, the grain size distribution of the sand and the chemical composition of the ground water (Johannesson et al. 1999).

The hydraulic conductivity of the tight sections with bentonite blocks at its expected average dry density $1,400 \text{ kg/m}^3$ will be 10^{-12} – 10^{-13} m/s but may increase slightly due to the swelling.

Piping and erosion of the bentonite sections may lead to increased hydraulic conductivity if the pipes are not healed sufficiently (see Section 10.2.4).

The concrete plugs in contact with the tight sections of bentonite will affect the properties of the bentonite. See Section 7.4.10 (10.4.8) Montmorillonite transformation.

The hydraulic conductivity of concrete depends very much on the quality of the concrete. If the concrete is free from fractures the hydraulic conductivity may be very low. However, the existence of joints and probable cracks will dominate the hydraulic behaviour and after cement degradation the sealing effect will be lost. The hydraulic conductivity of degraded cement and concrete is expected to be in the same order of magnitude as sand.

Freezing may accelerate the degradation, see Section 10.1.2.

Dependencies between process and system component variables

Table 10-4 summarises how the process influences and is influenced by all Plug and closure processes variables and how these effects are handled. In addition, the handling of each influence in SR-PSU is indicated in the table.

Boundary conditions

The plugs and other closure components have the rock, an adjacent closure component and in some case the backfill around the waste as boundaries.

Table 10-4. Direct dependencies between the process “Water transport under saturated conditions” in the Plug and closure and the defined variables and a short note on the handling

Variable	Variable influence on process		Process influence on variable	
	Influence present? Yes/No Description	Handling of influence How/If not – Why	Influence present? Yes/No Description	Handling of influence How/If not – Why
Geometry	Yes.	Geometry included in the model.	No.	–
Temperature	No, but indirectly through water viscosity.	Negligible.	No.	–
Hydrological variables	Yes, basic variables.	Variables in the model.	Yes.	Variable in the model.
Mechanical stresses	Yes. The swelling pressure of the tight bentonite sections will compress the concrete plugs after cement degradation, which results in changed geometry and density.	Yes, will be included in mechanical calculations (see Section 10.3.1).	Only during the compression.	Negligible.
Material composition	Yes, through hydraulic conductivity.	Influences the parameters in the model.	No, but indirectly through transport of degraded cement.	See Section 10.4.1 Advection and dispersion.
Water composition	Yes, may affect the hydraulic conductivity.	Influences the hydraulic conductivity.	No, but indirectly through transport of degraded cement since e.g. Ca may be dissolved in the flowing water.	See Section 10.4.1 Advection and dispersion.
Gas variables	No, since the process assumes water saturation.	–	No.	–

Model studies/experimental studies

Water flow in all materials proposed for the plugs and other closure components have been studied. For the clay based components, see e.g. Johannesson et al. (1999), Börgesson et al. (1995) and Karnland et al. (2006). There are also numerous examples of water flow in concrete structures in engineering practice.

Natural analogues/observations in nature

See Section 5.2.2.

Time perspective

The process starts when the plugs and other closure components have reached full water saturation and continues during the rest of the lifetime of the repository. The properties of the concrete will vary during this time due to the degradation.

Handling in the safety assessment SR-PSU

The process water transport under saturated condition will be decisive for the safety assessment. When the plugs and the other closure components are water saturated the entire repository is expected to have reached close to a steady state water pressure situation with only small regional pressure differences and water flow. The slow concrete degradation will successively change the hydraulic conductivity of the concrete plugs and the geometry of the neighbouring parts. This changes the flow situation locally but is not expected to influence significantly on the flow situation. This will however be checked (see Section 10.3.1).

A global model of the water flow in the repository should be made in order to see the effect of the plugs and other closure components.

Timescales: The time after saturation throughout the assessment period.

Boundary conditions: The expected hydraulic gradient in the surrounding rock will be used as boundary conditions. Different boundary conditions will be used to reflect the influence.

Handling of variables influencing this process: The model will be a hydraulic model and only include the geometry and the hydrological variables.

Handling of uncertainties in SR-PSU

Given the adopted handling in the safety assessment SR-PSU as described above, the handling of different types of uncertainties associated with the process will be summarised.

Uncertainties in mechanistic understanding: The general understanding of saturated flow in clay filling and concrete are rather good. The uncertainties are mainly related to the rock properties and the existence of cracks in the concrete, the degradation rate of the concrete and the properties of the degraded concrete. Piping and erosion may influence the hydraulic situation if the erosion is strong and the self healing insufficient (see Section 7.2.4).

Model simplification uncertainties: The water flow in the concrete will probably be simplified to water flow in a porous media with properties that vary with time according to the expected degradation rate.

Input data and data uncertainties: The properties of the cracks in the concrete, the degradation rate and the properties of the degraded concrete have large uncertainties but are not expected to influence the overall water flow situation significantly but will be included in the model.

10.2.3 Gas transport/dissolution

Overview/general description

In the tunnel system of SFR, bentonite is used as a hydraulic seal, while concrete and earth dam (bentonite/crushed rock) plugs are used as mechanical support to confine the bentonite. The tunnels will also be backfilled with crushed rock in order to mechanically support the plugs. The backfill is intended to maintain a hydraulic conductivity of 10^{-5} m/s or higher so that it does not influence the flow resistance in rock fractures, and therefore flow to the barriers.

The generic processes governing the gas transport and gas dissolution are described in Section 5.2.3 based on Moreno et al. (2001) and are not repeated here. The specific aspects of gas transport in bentonite and concrete plugs are essentially equivalent to the descriptions given for these components in the Silo, see Section 7.2.3. Release of gases formed in the waste, waste packaging, barriers and different construction elements such as rock bolts and steel reinforcement used in the plugs and other closure components, may accumulate in the backfill and affect the water flow, thereby having an impact on the intended backfill performance.

Specific issues related to the gas transport in the backfill material include the accumulation of gas collected from adjacent parts of the SFR repository, possible pressure build-up accompanied by displacement of pore water and the release of gas into the host rock. The foreseen backfill materials, which include crushed rock and earth materials used to mechanically support the plugs, are porous and have high gas permeability. The amount of gas accumulated is given by the necessary pressure build-up to overcome the entry pressure of the fractures in the host rock, which is generally expected to be low. However, in Section 3.2.6 it is stated that “...*If there is a hydraulically disturbed zone surrounding the tunnels the plugs shall be designed to seal this. The plugs shall be placed so that they are not short-circuited by water bearing fractures.*” This means that the plugs may in some locations also block the gas from reaching the most gas-permeable zones along the tunnels. Further, in Section 3.2.6 it is stated that “...*The backfill in tunnels and caverns shall not contain material that has a significant influence on the barriers by influencing the flow resistance in fractures in the rock.*” This means that the backfill material should not contain fine sized particles that may be eroded and transported to fracture openings where they could cause clogging, see Section 10.4.5. Other processes that may result in clogging of fracture entrances or clogging of the backfill material is also described in Section 10.4.5.

Dependencies between process and system component variables

Table 10-5 shows how the process influences, and is influenced by, all system variables.

Influence by geometry

Yes, a direct influence has been identified.

The pore geometry of the plugs and the crushed rock backfill and the interface to fracture zones in rock will affect the pressure build-up necessary to overcome the capillary pressure of the gas to be released into the host rock.

Influence on geometry

No direct influence has been identified.

Influence by temperature

Yes, a direct influence has been identified.

Temperature directly influences the volume of gas via the general gas law. The temperature also affects the density and viscosity of water and gas and thereby the flow resistance of water and gas. The temperature may also indirectly influence the solubility of gas in the water via the water composition.

Table 10-5. Direct dependencies between the process “Gas transport/dissolution” and the defined system variables and a short note on the handling in SR-PSU.

Variable	Variable influence on process		Process influence on variable	
	Influence present? Yes/No Description	Handling of influence How/If not – Why	Influence present? Yes/No Description	Handling of influence How/If not – Why
Geometry	Yes, the pore/fracture geometry will affect the pressure build-up due to gas accumulation.	Included in the modelling.	No direct influence identified.	Not relevant.
Temperature	Yes, temperature affects the density and viscosity of gases. Indirectly, the temperature affects the solubility via water composition.	No, judged negligible, only a small temperature range is expected in SFR. Different temperatures considered in climate scenarios.	Yes, but effects are judged negligible.	Neglected due to insignificant impact.
Hydrological variables	Yes, the aggregation state affects the possibility to dissolve and transport gas. Indirectly, the water flow influences the dissipation of gas via water composition.	Considered in climate scenarios.	Yes, gases can block the flow or change the flow pattern of water.	Considered negligible.
Mechanical stresses	No direct influence identified.	See Section 10.3.1.	Yes, gas accumulation in the backfill could lead to a build-up of pressure.	Considered in scenarios.
Material composition	Yes, the material composition influences the hydraulic and capillary properties.	Considered in the selection of input data.	No direct influence identified.	Not relevant.
Water composition	Yes, the water composition is of fundamental importance in controlling the dissolution of gases.	Yes, included in the modelling.	Yes, dissolution of gases affects the water composition.	Yes, included in the modelling.
Gas variables	Yes, the composition of gas affects the density and viscosity of the gas.	Considered in the selection of input data.	Yes, a fundamental impact on the gas variables.	Considered in the selection of data for gas transport modelling.

Influence on temperature

Yes, a direct influence has been identified.

Gas transport can involve heat transfer. However, SFR will be at the ambient temperature, thus transport of heat by escaping gases is thought to be negligible, and will have no impact on the temperature of SFR. Heat exchange due to compression of gas in the repository and subsequent expansion during escape through the concrete barriers and plugs is also judged to have a negligible impact.

Influence by hydrological variables

Yes, a direct influence has been identified.

During permafrost and/or glaciations, the pore water may freeze and block the pores, hence prevent the transport of gas through the barriers, the plugs and the backfill. However, under these conditions it is also likely that the gas formation processes would halt (see Section 5.4.10).

There is an indirect effect via water composition since different minerals in the plugs and the backfill will maintain chemical equilibrium with the water passing through; hence the mineral alteration rate will be proportional to the rate of water exchange.

Influence on hydrological variables

Yes, a direct influence has been identified.

Gas that accumulates may block the flow of water, or may change the flow pattern.

Influence by mechanical stresses

No direct influence has been identified.

In general, mechanical stresses may affect chemical equilibria where the volume of solid phase changes. Rock fallout may cause such stress locally. However, the indirect impact of mechanical stresses on the material properties and the resulting flow of gas and water are judged negligible.

Influence on mechanical stresses

Yes, a direct influence has been identified.

Yes, accumulation of gas in the backfill could lead to a pressure build-up.

Influence by material composition

Yes, a direct influence has been identified.

Yes, the material composition influences the hydraulic and capillary properties.

Influence on material composition

No direct influence has been identified.

Influence by water composition

Yes, a direct influence has been identified.

Yes, the water composition is of fundamental importance in controlling the dissolution of gases.

Influence on water composition

Yes, a direct influence has been identified.

Dissolution of gases affects the water composition.

Influence by gas variables

Yes, a direct influence has been identified.

The composition of gas affects the density and viscosity of the gas.

Influence on gas variables

Yes, a direct influence has been identified.

This process has a fundamental and essentially defining influence on the gas variables.

Boundary conditions

The boundaries of this analysis are the backfill material with exchange of gas with the adjacent parts of the SFR repository including the waste/waste package and the surrounding geosphere considered.

Model studies/experimental studies

Model studies/experimental studies of relevance for gas transport/dissolution in the other parts of the SFR repository are equally relevant for the plugs, backfilling and other closure components; see descriptions given in Section 5.2.3.

Natural analogues/observations in nature

Not applicable.

Time perspective

Gas transport/dissolution processes are expected in the plugs, backfill and other closure components from the point of closure of SFR. See more detailed description in Section 5.2.3.

Handling in the safety assessment SR-PSU

See Section 5.2.3.

Handling of uncertainties in SR-PSU

See Section 5.2.3.

Adequacy of references supporting the handling in SR-PSU

See Section 5.2.3..

10.2.4 Piping/erosion**Overview/general description**

Water inflow into the bentonite based sections of the plugs and the other closure components will take place mainly through fractures in the rock and from the crushed rock sections via cracks in partition walls and will contribute to the wetting of the bentonite based sections. However, if the inflow is localised to fractures that carry more water than the bentonite based materials can absorb, there will be a water pressure in the fracture acting on the bentonite. Since the bentonite based materials in contact with the rock surfaces is either pellets with low density or 30/70 mixtures of bentonite and crushed rock it may be unable to stop the water inflow. The results may be piping in the bentonite, formation of a channel and a continuing water flow and erosion of soft bentonite gel.

The process is described in Section 7.2.4.

The risk of piping and erosion in the bentonite/sand mixture is smaller due to the high density and low water pressure but it cannot be excluded. The other filling materials cannot be subjected to piping and erosion.

Dependencies between process and system component variables

Table 10-6 summarises how the piping process influences and are influenced by all plugs and other closure components variables. In addition, the handling of each influence in SR-PSU is indicated in the table and more thoroughly discussed in the text below. *Since piping and erosion can only take place in the bentonite based materials, the table only refers to these parts.*

Boundary conditions

The bentonite based materials have the rock and the partition walls as boundaries. Piping may start at the rock fractures if water inflow is not stopped.

Model studies/experimental studies

See Section 7.2.4.

Natural analogues/observations in nature

Piping and erosion may occur in natural deposits but has so far not been studied.

Time perspective

The piping and erosion (excluding colloid erosion) takes place only before complete saturation, homogenisation and pore water pressure equilisation. The swelling of the bentonite is expected to seal the piping channels in the sections with blocks and pellets. After re-establishment of the natural ground water situation the hydraulic gradients will be so low that erosion will not occur.

Table 10-6. Direct dependencies between the processes piping and erosion in the bentonite filling in the plugs and other closure components and the defined variables and a short note on the handling.

Variable	Variable influence on process		Process influence on variable	
	Influence present? Yes/No Description	Handling of influence How/If not – Why	Influence present? Yes/No Description	Handling of influence How/If not – Why
Geometry	Yes, the path length has an influence.	No, the path length is not included in the simple model.	Yes, through lost bentonite.	Amount of lost bentonite is calculated.
Temperature	No.	–	No.	–
Hydrological variables	Yes, basic variables.	The hydraulic gradient, the water flow rate and the duration are included.	No, but indirectly by changing the viscosity of the eroding water and indirectly through changes in material composition, density and stresses.	See below.
Mechanical stresses	Yes, determines if piping occurs.	Included in the analyses.	No, but indirectly through changes in material composition, density and stresses.	Yes, may change the density and the stresses and will be included in the assessment.
Material composition	Yes, affects important variables.	Included in the analyses.	Yes, through lost material and may change the composition.	Yes, estimations based on laboratory tests will be made.
Water composition	Yes, the salinity of the ground water affects the erosion rate.	Included in the analyses.	Yes, there will be particles in the eroding water, which will change the viscosity.	No, small effect.
Gas variables	Yes, the degree of saturation has an influence.	Will to some extent be included in the analyses.	No.	

Handling in the safety assessment SR-PSU

The consequences of piping and erosion may be a loss of large quantities of bentonite if the time until water saturation and establishment of hydrostatic condition after emplacement of the bentonite is long and if the water flow is strong.

The same type of estimation of material loss as was done for SR-Site will be done. If the time is long the material loss may be strong.

Example:

According to Equation 7-2 (Section 7.2.4) the loss of material can be calculated:

$$m_s = \beta \times (m_w)^\alpha \quad (7-2)$$

where

m_s = accumulated mass of eroded bentonite (g)

m_w = accumulated mass of eroding water (g)

β = 0.02–2

α = 0.65

Since the water flow is horizontal the highest value of β must be used. For an inflow of 1 L/min into a hydraulic tight section the total erosion can be calculated as a function of the time. If it takes 20 years for re-establishment of hydrostatic conditions, the total time is 10^7 minutes, which yields a total inflow of 10^4 m³, which yields $m_w = 10^{10}$ g. The accumulated mass of eroded bentonite will then be $m_s = 6.3 \cdot 10^6$ g or 6.3 tons of bentonite.

Timescales: The time after emplacement of bentonite until full saturation and establishment of hydrostatic conditions.

Handling of variables influencing this process: The water flow and the water pressure are the key variables for the piping. Erosion is also affected by the geometry of the bentonite filling. The effect of the salinity of the groundwater is also included in the description. All of these variables are included in the model that will be used.

Handling of variables influenced by the process: The consequence of extensive piping together with erosion would be a loss of bentonite density, which will be calculated for different cases.

Handling of uncertainties in SR-PSU

Given the adopted handling in the safety assessment SR-PSU as described above, the handling of different types of uncertainties associated with the process will be summarised.

Uncertainties in mechanistic understanding: Piping, erosion and subsequent sealing is a complicated process with many components, much depending on the hydraulic behaviour of the rock. The uncertainties are considerable regarding both the water flow in the rock and the ability of the buffer to resist these processes.

Knowledge of when piping and erosion might occur and the consequences are not fully understood at present. Further tests are ongoing and planned.

Model simplification uncertainties: The erosion model model is so far based entirely on empirical data.

Input data and data uncertainties: The data used in the model is uncertain since there is quite a scatter in measured results but by using the value $\beta=2$ a pessimistic estimation will be done.

10.3 Mechanical processes

10.3.1 Mechanical processes

Overview/general description

A number of mechanical processes may occur in the plugs and other closure components. Most of them are of insignificant importance for the safety, but there are some that needs to be attended to.

The following is a list of important mechanical processes in the **tight sections made of bentonite blocks and pellet filling**:

- Swelling by wetting.
- Swelling pressure after wetting.
- Self-sealing of erosion damages.
- Deformation caused by stress changes.
- Swelling after concrete degradation.
- Indirect mechanical consequences of bentonite/cement interaction.

Water is absorbed by both unsaturated and saturated bentonite (that is able to physically expand) and causes swelling. If the bentonite is unable to expand freely, a swelling pressure develops, which reaches its peak at full water saturation.

In the tight sections, the bentonite is initially inhomogeneous due to the pellet filled gaps between the bentonite blocks and the rock. When water from the rock fills the pellet-filled slot and enters the bentonite blocks there will be swelling of the blocks and compression of the pellet filling. At first the swelling will be large because of the overall low bulk density of the pellet-filled slot. The resistance to compression is thus small relative to that of the blocks. This means that the outer part of the blocks will swell to a lower density than the average density expected after complete homogenisation. Ultimately, the water will be drawn so deeply into the blocks that the swelling pressure compresses both the pellet-filled gap and the swollen outer part of the blocks. With time, saturation is achieved and the compression of the outer part and the expansion of the inner part will come to some kind of equilibrium. This will not be a completely homogenous material due to inner friction in the bentonite and hysteresis effects. A small density gradient is expected to persist with higher density in the centre of the block filling and lower close to the rock. The average dry density of the bentonite is expected to about 1,400 kg/m³, which yields a swelling pressure of 2–4 MPa (see e.g. Børgesson et al. 1995 and Karnland et al. 2006).

Swelling may also lead to compression of the transition materials placed between the tight sections and the crushed rock. Depending on the conditions in the near-field rock, the clay in the fractures could be carried away by groundwater with gradual erosion of the bentonite (see Section 10.2.4).

After degradation of the cement in the concrete plugs and partition walls the ballast material will be compressed by the swelling of the bentonite.

The process of bentonite swelling and generation of swelling pressure is described in Section 7.3.1.

The mechanical processes in the **transition sections made of bentonite/sand filling** are similar in nature but less important due to that they have no sealing function. The swelling pressure of 30/70 bentonite sand mixture is small and depends on density and porewater composition. At the expected dry density after in situ compaction 1,600–1,800 kg/m³ the swelling pressure is about 100–500 kPa.

The **concrete** may also be affected by a number of mechanical processes, most of them being of minor importance. The following processes may influence the hydro-mechanical evolution of the plugs:

- Stresses and deformation caused by the swelling pressure of the bentonite.
- Effects of concrete degradation caused by chemical processes.
- Stresses caused by corrosion of the reinforcement.
- Cracking.
- Effects of freezing.

In the long time perspective the concrete is expected to crack and be degraded by chemical processes. This may ultimately lead to a stack of residual products of mainly the ballast material with properties similar to sand.

The **backfill of crushed rock in the tunnels and shafts** are affected by the following mechanical processes:

- Stresses caused by the own weight.
- Settlement by wetting.
- Deformation caused by stress changes from neighboring sections.
- Creep deformations.
- Effects of displacements and fall out in the roof and walls of the rock vault.

The mechanical processes in the backfill are identical to the ones in BMA described in Section 5.3.1.

Dependencies between process and system component variables

Table 10-7 summarises how the mechanical processes influences and are influenced by all plug and other closure components variables.

The geometry is important for the stresses and subsequent deformations. Friction effects against the rock and other boundaries reduce deformations. The geometry may change when the swelling pressure is higher than the adjacent material can withstand. After degradation of the cement the concrete may not resist the swelling pressure from the bentonite.

The temperature has a small influence on the mechanical processes unless the temperature is below zero, when it may cause freezing and thus affect the different materials. See Section 10.1.2.

The hydrological variables such as water pressure and water compressibility and the **mechanical stresses** are included in the hydro-mechanical models. There is coupled interaction between water pressure and mechanical stresses.

The swelling pressure of the bentonite is an important mechanical variable that is affected by the density and water composition.

The material composition has of course a large influence on the mechanical properties, not only due to the strong difference between the different types of materials but also within each type of materials.

The water composition also influences the swelling pressure but this effect is only significant for 30/70 mixtures.

Table 10-7. Direct dependencies between the mechanical processes in the plug and other closure components and the defined variables and a short note on the handling.

Variable	Variable influence on process		Process influence on variable	
	Influence present? Yes/No	Description Handling of influence How/If not – Why	Influence present? Yes/No	Description Handling of influence How/If not – Why
Geometry	Yes.	Included in the models.	Yes.	Included in the model.
Temperature	Yes.	Negligible.	No.	
Hydrological variables	Yes.	Included in HM models.	Yes.	Included in HM-models.
Mechanical stresses	Yes.	Included in HM models.	Yes.	Included in HM models.
Material composition	Yes, determines the mechanical properties.	Sets the parameters in the model.	No.	
Water composition	Yes for 30/70 mixture.	Sets the parameters in the model.	No.	
Gas variables	Yes, gas pressure may be generated.	Analysis of the importance of gas pressure on the mechanical integrity of the plugs.	No.	

Boundary conditions

The plugs and other closure components have the rock, an adjacent closure component and in some case the backfill around the waste packages as boundary. Some boundaries are of special importance due to the mechanical interaction between the materials at the boundary.

Interaction concrete plug/bentonite filling

The concrete plug is in contact with the high density bentonite filling either directly or via a partition wall of concrete. There will thus be a swelling pressure from the bentonite onto the concrete. In the first part of the life time of the repository when the concrete is intact the concrete plug will resist the swelling pressure and there will be high pressure on the plug but very small displacements. The concrete plugs must thus be built to resist the swelling pressure and the tight section of bentonite must be made to yield a limited swelling pressure.

With time the cement will degrade and the concrete lose its strength. This will make the bentonite swell and compress the rest products (ballast material). Eventually the ballast material will be displaced and compress the filling on the other side.

Interaction bentonite filling/transition material

The high density bentonite filling is in contact with the transition material of 30/70 mixture via partition walls. Since the swelling pressure of the transition material is much lower than that of the bentonite filling there will be a swelling of the bentonite filling and compression of the transition material and eventually also displacement of the transition material.

Interaction between the filling materials and the rock

The bentonite based filling materials will exert a swelling pressure on the rock. This will keep possible loose rock parts in place. The unevenness of the rock surface will create friction between the filling materials and the rock so that possible axial movements parallel to the rock surface will be hindered. Instead of sliding against the rock surface the shear strength of the material must be overcome before any axial movements can occur. The swelling or compression of filling materials is thus counteracted by this friction.

Interaction between the transition material and the backfilling with crushed rock

Although the swelling pressure of the transition material is not strong it will act on the crushed rock that fills a large part of the transport tunnels.

Interaction between closure materials and the backfill around the waste in the different parts of the repository.

Not critical but will be checked.

Model studies/experimental studies

A large number of laboratory tests, field tests and modelling exercises have been performed on the bentonite based materials that will be used in the tight sections of bentonite blocks and the transition sections of 30/70 mixtures. These studies were made for KBS-3. Bentonite blocks with surrounding pellet filling will be used both as buffer material in the deposition holes and as backfilling in the deposition tunnels. There is thus a large amount of knowledge available and the swelling and sealing capacity of high density bentonite are investigated in ongoing projects. See e.g. Börgesson et al. (1995) and Åkesson et al. (2010).

30/70 mixtures are not planned to be used in the present design of KBS-3, but there are several old investigations concerning this material. See e.g. Johannesson et al. (1999).

Natural analogues/observations in nature

See Section 5.3.1.

Time perspective

The entire life time of the repository will be handled. See handling in the safety assessment.

Handling in the safety assessment SR-PSU

Since the plugs and the other closure components are vital for the sealing ability of the repository and thus for the safety it is important to assure that there are no mechanical effects that may jeopardise their sealing function. Especially the interactions between different parts will be handled.

The sealing of the access and transport tunnels are mainly taken care of by the tight sections of bentonite filling with blocks and pellets. The hydromechanical function of these sections and their interaction with the neighboring materials will be investigated. The studies need to consider all types of plugs and filling materials.

The following issues will be handled in the safety assessment:

- Swelling and homogenisation of the bentonite blocks and pellets filling in the tight sections and their final pressure on the intact concrete plugs. This information is of interest for estimating the sealing ability and the pressure distribution on the intact concrete plugs.
- The interaction between the tight bentonite sections and the degraded concrete plug. The loss of density of the bentonite caused by compression and possible displacement of the plug will be studied for all plug geometries planned.
- The interaction between the tight bentonite sections, the transition sections and the backfilling in the waste areas.
- Some waste areas are planned to be left open. This may cause problems when the concrete plugs degrade, since the bentonite may then swell into the open parts. This scenario needs to be investigated.
- The effect of possible material lost by erosion and how such a loss may be healed. The largest possible amount of lost bentonite according to calculations proposed in Section 10.2.4 will be studied.

Timescales: The entire life time of the silo will be included. The processes can be divided into two different time periods; before and after degradation of the cement. The time before degradation is rather stable and includes only the water saturation and the self-sealing and homogenisation of the bentonite filling as a critical process. Both periods will be included in the analyses.

Boundary conditions: The rock surface will be a mechanical non-deformable boundary. The boundaries in the tunnel directions will be located so far away that there are no displacements.

Handling of variables influencing this process: All the influencing variables in the table, except temperature and gas, will be included in the analyses. Gas pressure is handled as a boundary condition.

Handling of variables influenced by this process: The geometry, the hydrological variables and the mechanical variables will be influenced and included in the analyses.

Handling of uncertainties in SR-PSU

Given the adopted handling in the safety assessment SR-PSU as described above, the handling of different types of uncertainties associated with the process will be summarised.

Uncertainties in mechanistic understanding: The knowledge and understanding of the hydro-mechanical properties and behavior of the bentonite based materials that will be used are quite good and can be used for the analyses. There are ongoing investigations especially considering the swelling and self healing properties of bentonite.

The mechanical properties of the un-degraded concrete are well known and the mechanical processes well understood. The properties during and after degradation are more uncertain. A way to overcome these uncertainties may be to treat the concrete as completely degraded and turned into a sand heap after a certain time.

Model simplification uncertainties: The lack of knowledge of the properties of the degraded concrete may make it necessary to treat the concrete as completely degraded and turned into a sand heap after a certain time.

Input data and data uncertainties: See model simplifications. Otherwise the current knowledge is sufficient for performing the analyses.

10.4 Chemical processes

10.4.1 Advection and dispersion

Overview/general description

In SFR, bentonite filled tunnel sections are used as hydraulic seals between the conductive access tunnels and the waste containing vaults and Silo repositories. Concrete or earth dam plugs are used as mechanical support to confine the low-conductive bentonite, and crushed rock is used as backfill in the system of access tunnels (see further Section 2.9). Earth dam plugs typically consist of clay/sand/gravel of different sieve fractions that provides a transition in hydraulic properties between the materials on opposite sides of the plug, e.g. low-conductivity bentonite on one side and highly conductive crushed rock on the opposite side.

Advective transport of dissolved species within these different plug materials is to a large extent related to the water flow in the plugs, which is described separately for the cases of unsaturated and saturated conditions in Sections 10.2.1 and 10.2.2.

Concrete is used in many engineered structures in SFR, and the processes of advective transport and dispersion is described in detail for the concrete barriers of BMA (Section 5.4.1). The influences between advection/dispersion and the defined system variables identified for the concrete barriers in BMA, as well as the corresponding handling of these influences are also applicable to the concrete plugs in the present section.

Bentonite is used as a hydraulic seal in the barrier system of the Silo repository. The influences between advection/dispersion and the defined system variables for the Silo repository (Section 7.4.1) as well as the corresponding handling are also applicable to the bentonite plugs in the present section.

The crushed rock used for backfilling the system of access tunnels has a relatively large hydraulic conductivity to minimise the influence on the flow resistance in natural rock fractures. Thus, this backfill material is not intended to prevent water flow and has no attributed safety function for limited advective transport (see Section 3.2). Instead, the main function of the backfill is to contribute to the long term performance of the plugs by providing mechanical support.

Dependencies between process and system component variables

The dependence between the process variables and concrete structures and bentonite backfill is described in Sections 5.4.1 and 7.4.1 for the BMA and Silo barriers respectively, and is therefore not re-evaluated here.

Boundary conditions

The boundary conditions for the processes of advection and dispersion are the groundwater flow rates, the degree of water saturation and the groundwater chemical composition at the physical boundaries of the plugs and other closure components.

Model studies/experimental studies

For descriptions of model and experimental studies relevant for concrete and bentonite in the plugs, see Sections 5.4.1 and 7.4.1 for the BMA and Silo barriers respectively.

Natural analogues/observations in nature

For descriptions of natural analogues and observations in nature relevant for concrete and bentonite in the plugs, see Sections 5.4.1 and 7.4.1 for the BMA and Silo barriers respectively.

Time perspective

Advective transport by flowing groundwater will occur within the backfilled access tunnels and at least some plug and closure components, over the repository lifetime. A gradual loss of barrier function in concrete is presumed, in particular as a result of freeze damaging during periglacial permafrost.

Advection in bentonite is mainly relevant during the saturation process, and can typically be neglected after saturation, when diffusion will dominate.

Handling in the safety assessment SR-PSU

Evaluated from the modelling of the repository's hydraulic function. A coarsely discretised compartment approach is applied in modelling, which implicitly implies an estimate of dispersion in the plug and other closure components.

Handling of uncertainties in SR-PSU

Uncertainties in mechanistic understanding: Advection and dispersion processes can be considered mature science and the conceptual uncertainties are small.

Model simplification uncertainties: The model simplifications relate to the representation of the complex geometries of the different concrete, bentonite, and earth dam transition material constructions and the inherent heterogeneities introduced by variations in material composition, joints between construction elements, occurrence of fractures and the uncertainties related to the prediction of change of advective transport barrier properties in response to ongoing degradation processes over time. The assignment of boundary conditions to reflect the changes of groundwater chemical composition over time may introduce additional uncertainties.

The numerical dispersion introduced by the relatively coarse discretisation of the plugs and other closure components is considered to be conservative in that it likely is greater than the physical dispersion; however this remains a simplification uncertainty.

Input data and data uncertainties: Uncertainties with respect to flow properties in concrete are considered when assigning input data values in modelling. The sensitivity to this data uncertainty is checked by parameter variations and scenario analyses.

Adequacy of references supporting the handling in SR-PSU

See Sections 5.4.1 and 7.4.1.

10.4.2 Diffusion

Overview/general description

Diffusive mass transfer describes the transport of solutes through random motion along their concentration gradient (from regions of higher concentration to regions of lower concentration) in non-flowing water (in the absence of a hydraulic gradient). It affects major constituents of the aqueous phase as well as radionuclides. A general description of the process in a porous medium is given in Section 7.4.2, and the effects that need to be considered in case of a charged medium such as bentonite are also discussed there. These effects can be expected to be of minor importance in the earth dam material.

Dependencies between processes and system component variables

Due to the similarity in composition, dependencies between the process and system component variables are the same as in case of bentonite and bentonite/sand mixtures, see Table 7-9.

Boundary conditions

See Section 7.4.2.

Model studies/experimental studies

See Section 7.4.2.

Natural analogues/observations in nature

See Section 7.4.2.

Time perspective

See Section 7.4.2.

Handling in the safety assessment SR-PSU

Before saturation, the repository evolution is not considered explicitly. After saturation, the process is neglected, as the diffusive resistance can be expected to be higher in the plugs than in their environment (based on their function as hydraulic seal).

Handling of uncertainties in SR-PSU

Not applicable.

10.4.3 Sorption (including ion-exchange of major ions)

Overview/general description

Sorption in bentonite and sand is described essentially by two types of surface chemical reactions, surface complexation and ion exchange, which are responsible for the liquid–solid distribution of major ions and radionuclides. This is important with regard to radionuclide migration, bentonite evolution and porewater composition.

A general description of the process is given in Section 7.4.3, as well as a description of aspects specific for bentonite, which is the main component of the plugs. Quartz (sand) is also addressed. The earthdam plugs also contain crushed rock, which is assumed to mainly contain quartz, feldspar and micas. The surfaces on mica minerals are similar to those on clays, and sorption processes are comparable. For a few cations that easily give up their hydration shell (mainly Cs^+ , K^+ , NH_4^+), the (weathered) edges of micas offer high-affinity sites with a high selectivity for these cations (Sposito 1981, Zachara et al. 2002). Similar to the frayed edge sites of illite, these are not accessible to other ions due to steric reasons and therefore highly selective for Cs^+ , K^+ , NH_4^+ . Based on their mineral structure, the role of feldspars for sorption is assumed to be negligible.

Sorption in concrete is generally described in Section 5.4.3. In contrast to bentonite, sand and rock surfaces where sorption refers to a surface process, sorption in cementitious material includes additional uptake processes, such as the formation of solid solutions and incorporation reactions.

Dependencies between processes and system component variables

Due to the similarity in composition, dependencies between the process and system component variables are the same as in case of the respective bentonite (and bentonite/sand mixtures) and concrete components in the Silo and BMA, see Table 7-10 and Table 5-9.

Boundary conditions

See Sections 7.4.3 and 5.4.3.

Model studies/experimental studies

See Sections 7.4.3 and 5.4.3.

Natural analogues/observations in nature

See Sections 7.4.3 and 5.4.3.

Time perspective

See Sections 7.4.3 and 5.4.3.

Handling in the safety assessment SR-PSU

The process is neglected, since it is expected that solutes are not transported to the plugs by either advection or diffusion.

Handling of uncertainties in SR-PSU

Not applicable.

Adequacy of references supporting the handling in SR-PSU

Not applicable.

10.4.4 Alteration of impurities in bentonite**Overview/general description**

Bentonite consists mostly of smectite, but contains also accessory minerals as well as impurities. This process describes changes in the composition of these solids, but also of the suite of exchangeable cations on the smectite surface, during and following the saturation with water. A general description of the process is given in Section 7.4.4.

In case of the earth dam plugs, the crushed rock may also contain additional secondary minerals, depending on the degree of weathering. If present, these will behave similarly to the accessory minerals in bentonite.

Dependencies between processes and system component variables.

Due to the similarity in composition, dependencies between the process and system component variables are the same as in case of bentonite and bentonite/sand mixtures, see Table 7-11.

Boundary conditions

See Section 7.4.4.

Model studies/experimental studies

See Section 7.4.4.

Natural analogues/observations in nature

See Section 7.4.4.

Time perspective

See Section 7.4.4.

Handling in the safety assessment SR-PSU

Before saturation, the repository evolution is not considered explicitly. After saturation, the process is neglected, as the diffusive resistance can be expected to be higher in the plugs than in their environment (based on their function as hydraulic seal).

Handling of uncertainties in SR-PSU

Not applicable.

10.4.5 Dissolution, precipitation, recrystallisation and clogging in backfill

Overview/general description

The tunnel system of SFR will be backfilled with crushed rock in order to mechanically support the plugs. The backfill is intended to maintain a hydraulic conductivity of 10^{-5} m/s or higher so that it does not influence the flow resistance in rock fractures, and therefore flow to the barriers. Dissolution, precipitation and recrystallisation reactions in the backfill could affect the porosity and lead to clogging, thereby affecting the intended backfill performance.

The backfill will be exposed to an evolving water composition due to temporal changes in the composition of the groundwater and, in some locations, the leachate from the concrete and concrete/bentonite plugs. The water movement and diffusive pathways through the backfilled system will control the spatial extent to which the plugs influence the pore water chemistry of the backfill. The changing groundwater chemistry is described in Section 5.4.7, the evolution of concrete porewater chemistry in Section 5.4.6, while the alteration of impurities and montmorillonite for the plugs and other closure components are discussed in Sections 10.4.4 and 10.4.8, respectively.

The backfill material will undergo reactions with the inflowing groundwater in order to reach equilibrium. The exposure of new surfaces due to the crushing process will enhance the reactivity of the rock when it comes into contact with the groundwater. It is possible that surface storage of the crushed material may also lead to alterations of the reactive surface. Finally, the ongoing temporal changes in the groundwater composition will disrupt equilibria and cause further reactions to occur.

In the vicinity of concrete components, the crushed rock backfill will be exposed to highly alkaline conditions, which can lead to the alkaline dissolution of silicate minerals in the crushed rock and subsequent precipitation of new phases. The major ions released during concrete degradation are also important, with Na and K dominating the release in the early period, followed by Ca during the portlandite degradation phase. Aluminium, Si, Mg and Na are liberated during the alkaline leaching of bentonite (Section 7.4.10), although they may react within the concrete plugs before reaching the backfill.

Modelling of the Silo barrier system, which has bentonite and concrete barriers, has demonstrated the complex evolution of the mineralogy at the host rock interface (Gaucher et al. 2005). Minerals that were calculated to precipitate over time included:

- Ettringite ($\text{Ca}_6\text{Al}_2(\text{SO}_4)_3(\text{OH})_{12}\cdot 26\text{H}_2\text{O}$).
- CSH phases like: ($\text{Ca}_{1.8}\text{SiO}_9\text{H}_{10.4}$).
- Saponite-Ca ($\text{Ca}_{0.165}\text{Mg}_3\text{Al}_{0.33}\text{Si}_{3.67}\text{O}_{10}(\text{OH})_2$).
- Gismondine ($\text{Ca}_2\text{Al}_4\text{Si}_4\text{O}_{16}\cdot 9\text{H}_2\text{O}$).
- Gyrolite ($\text{Ca}_2\text{Si}_3\text{O}_7(\text{OH})_2\cdot 1.5\text{H}_2\text{O}$).
- Calcite (CaCO_3).

The zone where the cement-influenced porewater mixes with the groundwater is expected to experience significant dissolution, precipitation and recrystallisation reactions. For example, groundwater inputs of carbonate, sulphate, Ca^{2+} and Mg^{2+} may result in the precipitation of calcite (CaCO_3), magnesite (MgCO_3), brucite ($\text{Mg}(\text{OH})_2$) and possibly gypsum (CaSO_4) precipitation, which could clog either fractures in the host rock or pore space in the backfill.

Dependencies between process and system component variables

Table 10-8 shows how the process influences, and is influenced by, all system variables.

Influence by geometry

Yes, a direct influence has been identified.

The pore geometry within and between the crushed rock backfill will affect the extent to which clogging occurs following precipitation and recrystallisation reactions.

Influence on geometry

Yes, a direct influence has been identified.

Dissolution, precipitation and recrystallisation of solid phases can modify the porosity of the backfill.

Table 10-8. Direct dependencies between the process “Dissolution, precipitation, recrystallisation and clogging” and the defined system variables and a short note on the handling in SR-PSU.

Variable	Variable influence on process		Process influence on variable	
	Influence present? Yes/No	Description Handling of influence How/If not – Why	Influence present? Yes/No	Description Handling of influence How/If not – Why
Geometry	Yes, the pore geometry will affect the extent to which clogging occurs.	Neglected, since the process will have very limited or no impact on the repository performance.	Yes, dissolution – precipitation and recrystallisation of solid phases can modify the porosity of the backfill.	Neglected, since the process will have very limited or no impact on the repository performance.
Temperature	Yes, temperature affects dissolution, precipitation and recrystallisation reactions.	No, only a small temperature range is expected in SFR. Different temperature considered in climate scenarios.	Yes, dissolution, precipitation and recrystallisation reactions can involve a temperature change.	Considered negligible, the reactions in the backfill are not expected to be significantly heat generating.
Hydrological variables	No, only an indirect influence via water composition.	See water composition.	No, only indirectly, via material composition and geometry, and the associated changes in hydraulic conductivity.	Not relevant.
Mechanical stresses	Yes. In general, mechanical stresses may affect chemical equilibria where volume changes of solid phases are involved. Rock fallout may locally cause such stresses.	The impact is judged insignificant for the safety analysis of SFR.	Yes, clogging in the backfill could lead to a build up of pressure.	Neglected, since the process will have very limited or no impact on the repository performance.
Material composition	Yes, the material composition influences the reactions that occur.	Neglected, since the process will have very limited or no impact on the repository performance.	Yes, dissolution, precipitation and recrystallisation reactions affect the material composition.	Neglected, since the process will have very limited or no impact on the repository performance.
Water composition	Yes, the water composition is of fundamental importance in controlling the dissolution, precipitation and recrystallisation reactions that occur.	Neglected, since the process will have very limited or no impact on the repository performance.	Yes, dissolution, precipitation and recrystallisation reactions affect the water composition.	Neglected, since the process will have very limited or no impact on the repository performance.
Gas variables	No, only indirectly via water composition.	Not relevant.	No, only indirectly via water composition.	Not relevant.

Influence by temperature

Yes, a direct influence has been identified.

Temperature affects equilibria and rates of reactions; however temperature variations are expected to be negligible in SFR.

Influence on temperature

Yes, a direct influence has been identified.

The reactions in the backfill are not expected to be significantly heat generating, the actual impact on temperature is therefore judged negligible.

Influence by hydrological variables

No direct influence has been identified.

There is an indirect effect via water composition since different minerals in the backfill will maintain chemical equilibrium with the water passing through; hence the mineral alteration rate will be proportional to the rate of water exchange.

Influence on hydrological variables

No direct influence has been identified.

The dissolution–precipitation and recrystallisation of mineral phases in the backfill will influence hydrological variables indirectly via changes of the porosity and the pore structure of the backfill, which will affect the hydraulic properties. Dissolution of minerals may lead to increased porosity, increased hydraulic conductivity and increased hydraulic conductivity of the backfill. However, precipitation of secondary minerals may lead to decreased porosity and clogging of pores, therefore a decreased hydraulic conductivity.

Influence by mechanical stresses

Yes, a direct influence has been identified.

In general, mechanical stresses may affect chemical equilibria where the volume of solid phase changes. Rock fallout may cause such stress locally.

Influence on mechanical stresses

Yes, a direct influence has been identified.

Clogging could introduce mechanical stress in localised areas.

Influence by material composition

Yes, a direct influence has been identified.

Yes, the material composition influences the reactions that occur. Crushing rock to produce the backfill exposes new surfaces, which may undergo dissolution or recrystallisation reactions when they come in contact with groundwater.

Influence on material composition

Yes, a direct influence has been identified.

Dissolution, precipitation and recrystallisation reactions affect the material composition through leaching, deposition of new surface minerals and alteration of the existing minerals. The relatively high surface area of the crushed rock enhances the extent to which the material composition is affected by these processes.

Influence by water composition

Yes, a direct influence has been identified.

The water composition is of fundamental importance in controlling the dissolution, precipitation and recrystallisation reactions that occur. Different reactions will take place in the zones influenced by cement and bentonite leachate, and those that are dominated by the ambient groundwater composition. The changes in the groundwater composition over time will also affect the reaction equilibria and therefore the thermodynamically favoured mineral forms.

Influence on water composition

Yes, a direct influence has been identified.

Dissolution, precipitation and recrystallisation reactions affect the water composition.

Influence by gas variables

No direct influence has been identified.

There is, however, an indirect effect via water composition if the dissolved gases can take part in or affect reaction equilibria.

Influence on gas variables

No direct influence has been identified.

There is, however, an indirect effect via water composition if dissolution, precipitation and recrystallisation reactions remove dissolved gases from solution, resulting in further dissolution of gas, to maintain the equilibrium position.

Boundary conditions

The boundaries of this analysis are the backfill material with exchange of mass with the plugs, waste/waste package and the surrounding geosphere considered.

Model studies/experimental studies

Vuorinen et al. (2006) carried out experiments to assess the influence of fresh and saline alkaline leachates on crushed crystalline rock from the Olkiluoto disposal site in Finland. They identified the dissolution of microcline (KAlSi_3O_8) and the formation of sericite/illite ($\text{Al}_2\text{Si}_2\text{O}_7 \cdot 2\text{H}_2\text{O}(\text{K}, \text{H}_3\text{O})(\text{Al}, \text{Mg}, \text{Fe})_2(\text{Si}, \text{Al})_4\text{O}_{10}[(\text{OH})_2, (\text{H}_2\text{O})]$), and saw some evidence of other reactions. Minute amounts of CSH phases formed that were structurally analogous to 14\AA tobermorite ($\text{Ca}_5\text{Si}_6\text{H}_{10}\text{O}_{22}$).

Gaucher et al. (2005) modelled mineral alterations in the Silo, and included the changes in the host rock to a depth of 20 cm. Using a pore diffusion coefficient of 10^{-10} m²/s, they calculated that ettringite ($\text{Ca}_6\text{Al}_2(\text{SO}_4)_3(\text{OH})_{12} \cdot 26\text{H}_2\text{O}$) and a CSH phase ($\text{Ca}_{1.8}\text{Si}_9\text{H}_{10.4}$) would precipitate at the crystalline rock/shotcrete interface in the first 500 years, and by 10,000 years saponite-Ca ($\text{Ca}_{0.165}\text{Mg}_3\text{Al}_{0.33}\text{Si}_{3.67}\text{O}_{10}(\text{OH})_2$), gismondine ($\text{Ca}_2\text{Al}_4\text{Si}_4\text{O}_{16} \cdot 9\text{H}_2\text{O}$) and gyrolite ($\text{Ca}_2\text{Si}_3\text{O}_7(\text{OH})_2 \cdot 1.5\text{H}_2\text{O}$) would precipitate, the ettringite would have weathered and the CSH phase disappeared. These two stages were common to calculations that considered either a fresh or saline groundwater. However by 100,000 years differences had arisen between the two types of groundwater: in saline groundwater, quartz, ettringite, gismondine and gyrolite were calculated to have weathered, and saponite-Ca precipitation was on-going, whereas in fresh groundwater saponite-Ca, gyrolite and calcite (CaCO_3) would have precipitated and quartz would be weathered.

Increasing the pore diffusion coefficient to 10^{-9} m²/s resulted in a different mineral evolution.

For example, with saline groundwater, ettringite, tobermorite ($\text{Ca}_5\text{Si}_6\text{H}_{10}\text{O}_{22}$) and either chabazite ($\text{CaAl}_2\text{Si}_4\text{O}_{12} \cdot 6\text{H}_2\text{O}$) had precipitated by 500 years, and by 10,000 years, saponite-Ca and calcite had precipitated, while chabazite had weathered.

Although these studies demonstrate relevant alkaline alteration of host rock mineralogy, a recent report (Sidborn et al. 2014) discusses the need for site specific experimental data to “provide preliminary information on fracture sealing, rates of change in the fracture hydrology, mineral dissolution rates, surface areas of primary and secondary mineral phases and many other parameters that are currently open to speculation in the modelling effort”. Therefore, although significant clogging is less likely in the larger pore dimensions of the backfill compared to rock fractures, more site specific data may become available in the future to improve the predictive modelling.

Natural analogues/observations in nature

Granite contains fracture filling materials such as clays, oxides, carbonates, feldspars and zeolites arising from the interaction of local groundwaters with the rock (Savage 2011). High pH mineral alterations have been observed in sites such as Maqarin (e.g. Smellie 1998), although the bedrock is very different from the Forsmark area.

Time perspective

Dissolution, precipitation and recrystallisation reactions are expected in the backfill from the point of resaturation of SFR. The mineralogy is expected to change over time with the changes in the ambient groundwater, and with the changing cement leachate in affected zones.

Handling in the safety assessment SR-PSU

Mineral precipitation/dissolution will occur in the backfilled tunnel. The reactions will however have a very limited effect on the overall flow pattern in the SFR repository and are therefore neglected in the assessment.

Handling of uncertainties in SR-PSU

The process is neglected.

Adequacy of references supporting the handling in SR-PSU

The references are judged to be adequate and sufficient to support the handling in SR-PSU. All supporting references are either peer-reviewed articles or documents which have undergone factual review.

10.4.6 Aqueous speciation and reactions

Overview/general description

This process describes all aqueous chemical equilibria of major and trace constituents, including radionuclides. A general description is given in Section 7.4.8. The process is closely related to sorption (10.4.3), alteration (10.4.4) and dissolution/precipitation (10.4.5) processes.

Dependencies between processes and system component variables

Due to the similarity in composition, dependencies between the process and system component variables are the same as in case of bentonite and bentonite/sand mixtures, see Table 7-14.

Boundary conditions

See Section 7.4.8.

Model studies/experimental studies

See Section 7.4.8.

Natural analogues/observations in nature

See Section 7.4.8.

Time perspective

See Section 7.4.8.

Handling in the safety assessment SR-PSU

As for sorption (10.4.3), alteration (10.4.4) and dissolution/precipitation (10.4.5), the process is neglected in case of the plugs, as the resistance regarding transport of reactants can be expected to be higher in the plugs than in their environment (based on their function as hydraulic seal).

Handling of uncertainties in SR-PSU

Not applicable.

Adequacy of references supporting the handling in SR-PSU

Not applicable.

10.4.7 Osmosis

Overview/general description

Osmosis refers to a process taking place in a system of solutions divided by a semi-permeable membrane, where some, but not all, ions or molecules can pass between the two sides of the system parts. Karnland et al. (2005) described this process for the case of a bentonite barrier. Based on their concept, a general description is given in Section 7.4.9.

Dependencies between processes and system component variables

Based on the low bentonite content in comparison to the crushed rock material, it is assumed that this process is not relevant in case of the earth dam plugs.

Due to the similarity in bentonite composition, dependencies between the process and system component variables are the same as in case of the bentonite barrier, see Table 7-15.

Boundary conditions

See Section 7.4.9.

Model studies/experimental studies

See Section 7.4.9.

Natural analogues/observations in nature

See Section 7.4.9.

Time perspective

See Section 7.4.9.

Handling in the safety assessment SR-PSU

Based on the projected hydraulic resistance of the plugs, the process is neglected.

Handling of uncertainties in SR-PSU

Not applicable.

Adequacy of references supporting the handling in SR-PSU

Not applicable.

10.4.8 Montmorillonite transformation

Overview/general description

This process addresses the changes that montmorillonite may undergo as a result of interactions with dissolved ions. In the SFR repository, interaction with alkaline solutions from concrete components is of particular relevance. A corresponding overview is given in Section 7.4.10.

Dependencies between processes and system component variables

Due to the similarity in terms of composition as well as in terms of the placement next to concrete components, dependencies between the process and system component variables are the same as in case of the bentonite barrier in the Silo, see Table 7-16.

Boundary conditions

See Section 7.4.10.

Model studies/experimental studies

See Section 7.4.10.

Natural analogues/observations in nature

See Section 7.4.10.

Time perspective

See Section 7.4.10.

Handling in the safety assessment SR-PSU

The process is neglected, based on the high resistance regarding transport of reactants into the plugs.

Handling of uncertainties in SR-PSU

Not applicable.

Adequacy of references supporting the handling in SR-PSU

Not applicable.

10.4.9 Montmorillonite colloid release

Overview/general description

This process describes the dispersion of compacted bentonite following a local loss of swelling restriction. Under confined conditions, this process is not applicable. A general description of the process is given in Section 7.4.13. It is also discussed there under which Na/Ca concentrations the process can principally take place.

Dependencies between processes and system component variables

In principle, the dependencies between the process and system component variables are the same as in case of the bentonite barrier in the Silo, see Table 7-18. Due to the confinement by concrete or earth dam plugs, the process is not relevant, however.

Boundary conditions

See Section 7.4.12.

Model studies/experimental studies

See Section 7.4.12.

Natural analogues/observations in nature

See Section 7.4.12.

Time perspective

See Section 7.4.12.

Handling in the safety assessment SR-PSU

The process is neglected, based on the confinement of the bentonite by concrete or earth dam plugs, meaning that the Ca concentration from cement is sufficient to suppress this process.

Handling of uncertainties in SR-PSU

Not applicable.

Adequacy of references supporting the handling in SR-PSU

Not applicable.

10.4.10 Microbial processes

A general overview of microbial processes is given in the BMA section (5.4.8).

A large microbial activity can be expected in the backfilled tunnels, this will however have very limited effect on the properties of the backfill itself. In the bentonite plugs, microbial alteration could potentially be an issue, but this is still neglected with the same reasoning as for the bentonite in the silo (Section 7.4.13).

10.4.11 Degradation of rock bolts, reinforcement and concrete

Overview/general description

Metal is present in the rock bolts in the tunnel walls and the reinforcement in the concrete structures of the tunnel plugs. The corrosion of the metal will be controlled by the same processes as described for the BMA barriers in Section 5.4.9. As for the BMA barriers (Section 5.4.9), metal corrosion will be the major gas-formation process in the plugs. The concrete degradation processes described for the BMA barriers in Section 5.4.6 are also relevant for the concrete components of the plugs.

Dependencies between processes and system component variables

In principle, the dependencies between the process and system component variables are the same as for metal corrosion (Table 5-17) and concrete degradation (Table 5-12) in the BMA barriers. However, as there is relatively little metal present in the plugs, metal corrosion here generates a negligible proportion of the total gas in SFR. The reinforced concrete is present primarily to support

the bentonite filled sections of the tunnels, as long as the concrete plugs remain essentially intact, the status of the bentonite sections will remain intact. Although concrete degradation also affects bentonite via water chemistry (Section 7.4.10), the concrete in the plugs comprises a negligible amount of the total concrete in SFR and therefore has a limited effect on the water chemistry. However, following the eventual degradation of the concrete, the bentonite sections will be affected by the lack of mechanical support, see further discussion and handling in the safety assessment in Section 10.3.1.

Therefore the influences of the degradation of rock bolts and reinforcement in the plugs are neglected in the safety assessment, and the influence of concrete degradation is handled indirectly, via mechanical effects (Section 10.3.1).

Boundary conditions

See Sections 5.4.6 and 5.4.9.

Model studies/experimental studies

See Sections 5.4.6 and 5.4.9.

Natural analogues/observations in nature

See Sections 5.4.6 and 5.4.9.

Time perspective

See Sections 5.4.6 and 5.4.9.

Handling in the safety assessment SR-PSU

This process affects the stability of the bentonite sections in the plugs, and is therefore handled indirectly in the safety assessment SR-PSU, via mechanical effects (Section 10.3.1).

Handling of uncertainties in SR-PSU

See Section 10.3.1.

Adequacy of references supporting the handling in SR-PSU

See Section 10.3.1.

10.5 Radionuclide transport

10.5.1 Speciation of radionuclides

Overview/general description

This process describes the establishment of all chemical equilibria and reactions determining the thermodynamically and kinetically stable forms of radionuclides in pore solutions. It is a fundamental process whose general features are independent of the specific environment. A description is given in Sections 5.5.1 and 7.5.1.

Dependencies between processes and system component variables

In principle, the dependencies between the process and system component variables are the same as in case of the bentonite barrier in the Silo, see Table 7-21. In view of the transport resistance of the plugs, the process is not deemed relevant, however.

Boundary conditions

See Sections 5.5.1 and 7.5.1.

Model studies/experimental studies

See Sections 5.5.1 and 7.5.1.

Natural analogues/observations in nature

See Sections 5.5.1 and 7.5.1.

Time perspective

See Sections 5.5.1 and 7.5.1.

Handling in the safety assessment SR-PSU

The process is neglected, based on the transport resistance of the plugs.

Handling of uncertainties in SR-PSU

Not applicable.

Adequacy of references supporting the handling in SR-PSU

Not applicable.

10.5.2 Transport of radionuclides in the water phase

The plugs are not included in the radionuclide transport modelling. Their effects on radionuclide transport are only indirect via the reduction of the water flux they are causing.

10.5.3 Transport of radionuclides in the gas phase

The plugs are not included in the radionuclide transport modelling. Their effects on radionuclide transport are only indirect via the reduction of water flux they are causing.

References

SKB's (Svensk Kärnbränslehantering AB) publications can be found at www.skb.se/publications. References to SKB's unpublished documents are listed separately at the end of the reference list. Unpublished documents will be submitted upon request to document@skb.se.

References with abbreviated names

Main report, 2014. Safety analysis for SFR. Long-term safety. Main report for the safety assessment SR-PSU. SKB TR-14-01, Svensk Kärnbränslehantering AB.

Climate report, 2014. Climate and climate related issues for the safety assessment SR-PSU. SKB TR-13-05, Svensk Kärnbränslehantering AB.

Data report, 2014. Data report for the safety assessment SR-PSU. SKB TR-14-10, Svensk Kärnbränslehantering AB.

FEP report, 2014. FEP report for the safety assessment SR-PSU. SKB TR-14-07, Svensk Kärnbränslehantering AB.

Geosphere process report, 2014. Geosphere process report for the safety assessment SR-PSU. SKB TR-14-05, Svensk Kärnbränslehantering AB.

Initial state report, 2014. Initial state report for the safety assessment SR-PSU. TR-14-02, Svensk Kärnbränslehantering AB.

Model summary report, 2014. Model summary report for the safety assessment SR-PSU. SKB TR-14-11, Svensk Kärnbränslehantering AB.

Radionuclide transport report, 2014. Radionuclide transport and dose calculations for the safety assessment SR-PSU. SKB TR-14-09, Svensk Kärnbränslehantering AB.

Waste process report, 2014. Waste form and packaging process report for the safety assessment SR-PSU. SKB TR-14-03, Svensk Kärnbränslehantering AB.

Other references

Abarca E, Idiart A, de Vries L M, Silva O, Molinero J, von Schenk H, 2013. Flow modelling on the repository scale for the safety assessment SR-PSU. SKB TR-13-08, Svensk Kärnbränslehantering AB.

Abend S, Lagaly G, 2000. Sol-gel transitions of sodium montmorillonite dispersions. *Applied Clay Science* 16, 201–227.

Alexander W R, Smellie J A T, 2002. The Maqarin natural analogue project (1989–1998). In *Proceedings of the Eighth EC Natural Analogue Working Group Meeting, international workshop, Strasbourg, 23–25 March 1999*. Luxembourg: European Commission. (EC 19118 EN), 87–102.

Allard B, Dario M, Borén H, Torstenfelt B, Puigdomenech I, Johansson C, 2002. Karboxylatjonbytarmassans egenskaper. SKB R-02-40, Svensk Kärnbränslehantering AB. (In Swedish.)

Allen A J, Thomas J J, Jennings H M, 2007. Composition and density of nanoscale calcium-silicate-hydrate in cement. *Nature Materials* 6, 311–316.

Almkvist L, Gordon A, 2007. Low and intermediate level waste in SFR 1. Reference waste inventory 2007. SKB R-07-17, Svensk Kärnbränslehantering AB.

Álvarez J I, Navarro I, Martín A, García Casado P J, 2000. A study of the ancient mortars in the north tower of Pamplona's San Cernin church. *Cement and Concrete Research* 30, 1413–1419.

Andersland O B, Ladanyi B, 2004. *Frozen ground engineering*. 2nd ed. New York: Wiley.

Anderson C R, Pedersen K, 2003. In situ growth of *Gallionella* biofilms and partitioning of lanthanides and actinides between biological material and ferric oxyhydroxides. *Geobiology* 1, 169–178.

- Anderson C R, James R E, Fru E C, Kennedy C B, Pedersen K, 2006.** In situ ecological development of a bacteriogenic iron oxide-producing microbial community from a subsurface granitic rock environment. *Geobiology* 4, 29–42.
- Andreasson L, 1973.** Kompressionsegenskaper hos friktionsjord. Laboratiestudium. PhD thesis. Chalmers University of Technology, Sweden. (Byggnadsforskningen R36: 1973) (In Swedish.)
- Appelo C A J, Wersin P, 2007.** Multicomponent diffusion modelling in clay systems with application to the diffusion of tritium, iodide and sodium in Opalinus clay. *Environmental Science & Technology* 41, 5002–5007.
- Arcos D, Bruno J, Benbow S, Takase H, 2000.** Behaviour of bentonite accessory minerals during the thermal stage. SKB TR-00-06, Svensk Kärnbränslehantering AB.
- Arnold T, Zorn T, Zänker H, Bernhard G, Nitsche H, 2001.** Sorption behavior of U(VI) on phyllite: experiments and modelling. *Journal of Contaminant Hydrology* 47, 219–231.
- Atkins P W, De Paula J, 2006.** Atkins' physical chemistry. 8th ed. Oxford: Oxford University Press.
- Aviam O, Bar-Nes G, Zeiri Y, Sivan A, 2004.** Accelerated biodegradation of cement by sulphur-oxidising bacteria as a bioassay for evaluating immobilization of low-level radioactive waste. *Applied and Environmental Microbiology* 70, 6031–6036.
- Barbarulo R, Marchand J, Snyder K A, Prené S, 2000.** Dimensional analysis of ionic transport problems in hydrated cement systems Part 1. Theoretical considerations. *Cement and Concrete Research* 30, 1955–1960.
- Barbarulo R, Peycelon H, Leclercq S, 2007.** Chemical equilibria between C-S-H and ettringite, at 20 and 85°C. *Cement and Concrete Research* 37, 1176–1181.
- Baur I, Keller P, Mavrocordatos D, Wehrli B, Johnson A, 2004.** Dissolution–precipitation behaviour of ettringite, monosulfate, and calcium silicate hydrate. *Cement and Concrete Research* 34, 341–348.
- Bellmann F, 2004.** On the formation of thaumasite $\text{CaSiO}_3 \cdot \text{CaSO}_4 \cdot \text{CaCO}_3 \cdot 15\text{H}_2\text{O}$: Part I. *Advances in Cement Research* 16, 55–60.
- Belzile C, Gibson J A E, Vincent W F, 2002.** Colored dissolved organic matter and dissolved organic carbon exclusion from lake ice: Implications for irradiance transmission and carbon cycling. *Limnology & Oceanography* 47, 1283–1293.
- Benbow S, Walker C, Savage D, 2007.** Intercomparison of cement solid-solution models. Issues affecting the geochemical evolution of repositories for radioactive waste. SKI Report 2007:29, Statens kärnkraftinspektion (Swedish Nuclear Power Inspectorate).
- Bentz D P, 1999.** Modelling cement microstructure: pixels, particles, and property prediction. *Materials and Structures* 32, 187–195.
- Bentz D P, Garboczi E J, 1992.** Modelling the leaching of calcium hydroxide from cement paste: effects on pore space percolation and diffusivity. *Materials and Structures* 25, 523–533.
- Berger D, Braester C, 2000.** Gas-water displacement through fracture networks. *Water Resources Research* 36, 3205–3210.
- Berner U, 1990.** A thermodynamic description of the evolution of pore water chemistry and uranium speciation during the degradation of cement. Nagra Technical Report NTB 90-12, Nagra, Switzerland.
- Birgersson M, Karnland O, 2009.** Ion equilibrium between montmorillonite interlayer space and an external solution – Consequences for diffusional transport. *Geochimica et Cosmochimica Acta* 73, 1908–1923.
- Birgersson M, Karnland O, Nilsson U, 2008.** Freezing in saturated bentonite: a thermodynamic approach. *Physics and Chemistry of the Earth* 33, S527–S530.
- Birgersson M, Börjesson L, Hedström M, Karnland O, Nilsson U, 2009.** Bentonite erosion, Final report. SKB TR-09-34, Svensk Kärnbränslehantering AB.
- Birgersson M, Karnland O, Nilsson U, 2010.** Freezing of bentonite. Experimental studies and theoretical considerations. SKB TR-10-40, Svensk Kärnbränslehantering AB.

- Birgersson M, Hedström M, Karnland O, 2011.** Sol formation ability of Ca/Na-montmorillonite at low ionic strength. *Physics and Chemistry of the Earth, Parts A/B/C* 36, 1572–1579.
- Birnin-Yauri U A, Glasser F P, 1998.** Friedel's salt, $\text{Ca}_2\text{Al}(\text{OH})_6(\text{Cl},\text{OH})\cdot 2\text{H}_2\text{O}$: its solid solutions and their role in chloride binding, *Cement and Concrete Research* 28, 1713–1723.
- Björkenstam E, 1997.** Utveckling av SFR-bruket. Vattenfall Rapport UC 97:4Ö, Vattenfall Utveckling AB, Betongteknik, Älvkarleby. (In Swedish.)
- Bourg I C, Sposito G, Bourg A C M, 2006.** Tracer diffusion in compacted, water-saturated bentonite. *Clays and Clay Minerals* 54, 363–374.
- Bourg I C, Sposito G, Bourg A C M, 2007.** Modelling cation diffusion in compacted water-saturated sodium bentonite at low ionic strength. *Environmental Science & Technology* 41, 8118–8122.
- Bradbury M H, Baeyens B, 1999.** Modelling the sorption of Zn and Ni on Ca-montmorillonite. *Geochimica et Cosmochimica Acta* 63, 325–336.
- Bradbury M H, Baeyens B, 2003.** A comparison of apparent diffusion coefficients measured in compacted Kunigel V1 bentonite with those calculated from batch sorption measurements and De (HTO) Data: a case study for Cs(I), Ni(II), Sm(III), Am(III), Zr(IV) and Np(V). PSI Bericht Nr. 03-02, Paul Scherrer Institute, Switzerland.
- Braester C, Thunvik R, 1988.** Gas migration from low level radioactive repositories in hard rocks. *Nuclear Technology* 82, 60–70.
- Brandefelt J, Näslund J-O, Zhang Q, Hartikainen J, 2013.** The potential for cold climate conditions and permafrost in Forsmark in the next 60,000 years. SKB TR-13-04, Svensk Kärnbränslehantering AB
- Bruno J, Arcos D, Duro L, 1999.** Processes and features affecting the near field hydrochemistry. Groundwater–bentonite interaction. SKB TR-99-29, Svensk Kärnbränslehantering AB.
- Bruno J, Duro L, Grivé M, 2002.** The applicability and limitations of thermodynamic geochemical models to simulate trace element behaviour in natural waters. Lessons learned from natural analogue studies. *Chemical Geology* 190, 371–393.
- Börgesson L, Hernelind J, 1998.** Äspö Hard Rock Laboratory. Preparatory modelling for the backfill and plug test. Scoping calculations of H-M processes. SKB IPR-99-11, Svensk Kärnbränslehantering AB.
- Börgesson L, Johannesson L-E, Sandén T, Hernelind J, 1995.** Modelling of the physical behaviour of water saturated clay barriers. Laboratory tests, material models and finite element application. SKB TR 95-20, Svensk Kärnbränslehantering AB.
- Börgesson L, Sandén T, Fälth B, Åkesson M, Lindgren E, 2005.** Studies of buffers behaviour in KBS-3H concept. Work during 2002–2004. SKB R-05-50, Svensk Kärnbränslehantering AB.
- Börgesson L, Fälth B, Hernelind J, 2006.** Water saturation phase of the buffer and backfill in the KBS-3V concept. Special emphasis given to the influence of the backfill on the wetting of the buffer. SKB TR-06-14, Svensk Kärnbränslehantering AB.
- Börjesson K S, Emrén A T, Ekberg C, 1997.** A thermodynamic model for the calcium silicate hydrate gel, modelled as a non-ideal binary solid solution. *Cement and Concrete Research* 27, 1649–1657.
- Carde C, François R, Torrenti J-M, 1996.** Leaching of both calcium hydroxide and C-S-H from cement paste: modelling the mechanical behaviour. *Cement and Concrete Research* 26, 1257–1268.
- Catinaud S, Beaudoin J J, Marchand J, 2000.** Influence of limestone addition on calcium leaching mechanisms in cement-based materials. *Cement and Concrete Research* 30, 1961–1968.
- Chamberlain E J, Gow A J, 1979.** Effect of freezing and thawing on the permeability and structure of soils. *Engineering Geology* 13, 73–92.
- Chatterji S, 2004.** Ionic diffusion through thick matrices of charged particles. *Journal of Colloid and Interface Science* 269, 186–191.
- Chen J J, Thomas J J, Taylor H F W, Jennings H M, 2004.** Solubility and structure of calcium silicate hydrate. *Cement and Concrete Research* 34, 1499–1519.

- Cho W J, Lee J O, Chun K S, 1999.** The temperature effects on hydraulic conductivity of compacted bentonite. *Applied Clay Science* 14, 47–58.
- Crawford J, 2010.** Bedrock K_d data and uncertainty assessment for application in SR-Site geosphere transport calculations. SKB R-10-48, Svensk Kärnbränslehantering AB.
- Crawford J, Neretnieks I, Malmström M, 2006.** Data and uncertainty assessment for radionuclide K_d partitioning coefficients in granitic rock for use in SR-Can calculations. SKB R-06-75, Svensk Kärnbränslehantering AB.
- Cronstrand P, 2007.** Modelling the long-time stability of the engineered barriers of SFR with respect to climate changes. SKB R-07-51, Svensk Kärnbränslehantering AB.
- Cronstrand P, 2014.** Evolution of pH in SFR 1. SKB R-14-01, Svensk Kärnbränslehantering AB.
- Cross M M, Manning D A C, Bottrell S H, Worden R H, 2004.** Thermochemical sulphate reduction (TSR): experimental determination of reaction kinetics and implications of the observed reaction rates for petroleum reservoirs. *Organic Geochemistry* 35, 393–404.
- Cui D, Eriksen T E, 1995.** Reversibility of strontium sorption on fracture fillings. In Murakami T, Ewing R C (eds). *Scientific basis for nuclear waste management XVIII: symposium held in Kyoto, Japan, 23–27 October 1994*. Pittsburgh, PA: Materials Research Society. (Materials Research Society Symposium Proceedings 353), 1045–1052.
- Curti E, 1997.** Coprecipitation of radionuclides: basic concepts, literature review and first applications, PSI Bericht Nr. 97-10, Paul Scherrer Institute, Switzerland.
- Cuss R J, Harrington F J, Noy D J, 2010.** Large scale gas injection test (Lasgit) performed at the Äspö Hard Rock Laboratory. Summary report 2008. SKB TR-10-38, Svensk Kärnbränslehantering AB.
- Damidot D, Glasser F P, 1993.** Thermodynamic investigation of the $\text{CaO-Al}_2\text{O}_3\text{-CaSO}_4\text{-H}_2\text{O}$ system at 25°C and the influence of Na_2O . *Cement and Concrete Research* 23, 221–238.
- Damidot D, Glasser F P, 1995.** Thermodynamic investigation of the $\text{CaO-Al}_2\text{O}_3\text{-CaSO}_4\text{-CaCO}_3\text{-H}_2\text{O}$ closed system at 25°C and the influence of Na_2O . *Advances in Cement Research* 7, 129–134.
- Damidot D, Atkins M, Kindness A, Glasser F P, 1992.** Sulphate attack on concrete: limits of the AF_i stability domain. *Cement and Concrete Research* 22, 229–234.
- Damidot D, Birnin-Yauri U A, Glasser F P 1994a.** Thermodynamic investigation of the $\text{CaO-Al}_2\text{O}_3\text{-CaCl}_2\text{-H}_2\text{O}$ system at 25°C and the influence of Na_2O . *Cemento* 91, 243.
- Damidot D, Stronach S, Kindness A, Atkins M, Glasser F P, 1994b.** Thermodynamic investigation of the $\text{CaO-Al}_2\text{O}_3\text{-CaCO}_3\text{-H}_2\text{O}$ closed system at 25°C and the influence of Na_2O . *Cement and Concrete Research* 24, 563–572.
- Damidot D, Barnett S, Glasser F, Macphee D, 2004.** Investigation of the $\text{CaO-Al}_2\text{O}_3\text{-SiO}_2\text{-CaSO}_4\text{-CaCO}_3\text{-H}_2\text{O}$ system at 25°C by thermodynamic calculation. *Advances in Cement Research* 16, 69–76.
- Dash J G, Rempel A W, Wettlaufer J S 2006.** The physics of premelted ice and its geophysical consequences. *Reviews of Modern Physics* 78, 695–741.
- Davies P B, Brush L H, Mendenhall F T, 1992.** Assessing the impact of waste generated gas from the degradation of transuranic waste at the waste isolation pilot plant (WIPP): an overview of strongly coupled chemical, hydrologic, and structural processes. In *Gas Generation and Release from Radioactive Waste Repositories, Proceedings of the NEA Workshop, Aix-en-Provence, France, 23–26 September 1991*. Paris: OECD/NEA, 55–74.
- Davis J A, Kent D B, 1990.** Surface complexation modelling in aqueous geochemistry. In Hochella M F, White A F (eds). *Mineral-water interface geochemistry*. Washington, DC: Mineralogical Society of America. (Reviews in Mineralogy), 177–260.
- Davis J A, Payne T E, Waite T D, 2002.** Simulating the pH and $p\text{CO}_2$ dependence of uranium(VI) adsorption by a weathered schist with surface complexation models. In Zhang P C, Brady P V (eds). *Geochemistry of soil radionuclides*. Madison, WI: Soil Science Society of America. (SSSA Special Publication 59), 61–86.

- Davis J A, Curtis G P, Randall J D, 2003.** Application of surface complexation modelling to describe uranium (VI) adsorption and retardation at the uranium mill tailings site at Naturita, Colorado. NUREG/CR-6820, U.S. Geological Survey, U.S. Nuclear Regulatory Commission, Office of Nuclear Regulatory Research, Washington, DC.
- Degueldre C, Pfeiffer H-R, Alexander W, Wernli B, Bruetsch R, 1996.** Colloid properties in granitic groundwater systems. In Sampling and characterisation. Applied Geochemistry 11, 677–695.
- de Silva P S, Glasser F P, 1993.** Phase relations in the system CaO–Al₂O₃–SiO₂–H₂O relevant to metakaolin – Calcium hydroxide hydration. Cement and Concrete Research 23, 627–639.
- De Windt L, Marsal F, Tinseau E, Pellegrini D, 2008.** Reactive transport modelling of geochemical interactions at a concrete/argillite interface, Tournemire site (France). Physics and Chemistry of the Earth, Parts A/B/C 33, 295–305.
- Diercks M, Sand W, Bock E, 1991.** Microbial corrosion of concrete. Experientia 47, 514–516.
- Dixon D A, Graham J, Gray M N, 1999.** Hydraulic conductivity of clays in confined tests under low hydraulic gradients. Canadian Geotechnical Journal 36, 815–825.
- Donnan F G Z, 1911.** Theorie der Membrangleichgewichte und Membranpotentiale bei Vorhandensein von nicht dialysierenden Elektrolyten. Ein Beitrag zur physikalisch-chemischen Physiologie. Zeitschrift für Elektrochemie 17, 572–581. (In German.)
- Dullien F A L, 1998.** Capillary effects and multiphase flow in porous media. Journal of Porous Media 1, 1–29.
- Duro L, Grivé M, Domènech C, Roman-Ross G, Bruno J, 2012.** Assessment of the evolution of the redox conditions in SFR 1. SKB TR-12-12, Svensk Kärnbränslehantering AB.
- Dvinskikh S V, Szutkowski K, Furó I, 2009.** MRI profiles over very wide concentration ranges: application to swelling of a bentonite clay. Journal of Magnetic Resonance 198, 146–150.
- Dzombak D A, Morel F M M, 1990.** Surface complexation modelling: hydrous ferric oxides. New York: Wiley.
- EC, 2005.** ECOCLAY II. Effects of cement on clay barrier performance – Phase II. Final report. EUR 21921, European Commission.
- Emborg M, Jonasson J-E, Knutsson S, 2007.** Långtidsstabilitet till följd av frysning och tining av betong och bentonit vid förvaring av låg- och medelaktivt kärnavfall i SFR 1. SKB R-07-60, Svensk Kärnbränslehantering AB. (In Swedish.)
- Eng A, Nilsson U, Svensson D, 2007.** Äspö Hard Rock Laboratory. Alternative buffer material. Installation report. SKB IPR-07-15, Svensk Kärnbränslehantering AB.
- Engkvist I, Albinsson Y, Johansson Engkvist W, 1996.** The long-term stability of cement. Leaching tests. SKB TR 96-09, Svensk Kärnbränslehantering AB.
- Eriksen T E, Jansson M, 1996.** Diffusion of I⁻, Cs⁺ and Sr²⁺ in compacted bentonite. Anion exclusion and surface diffusion. SKB TR 96-16, Svensk Kärnbränslehantering AB.
- Eriksson S, 2008.** Äspö Hard Rock Laboratory. Prototype repository. Analysis of microorganisms, gases, and chemistry in buffer and backfill, 2004-2007. SKB IPR-08-01, Svensk Kärnbränslehantering AB.
- Fagerström H, Wiesel C-E, 1972.** Permeabilitet och kapillaritet: förslag till geotekniska laboratorieanvisningar, del 8. Stockholm: Statens institut för byggnadsforskning. (Byggnadsforskningens informationsblad B7:1972) (In Swedish.)
- Faucon P, Adenot F, Jacquinet J F, Petit J C, Cabrillac R, Jorda M, 1998.** Long-term behaviour of cement pastes used for nuclear waste disposal: review of physico-chemical mechanisms of water degradation. Cement and Concrete Research, 847–857.
- Favre F, Tessier D, Abdelmoula M, Génin J M, Gates W P, Boivin P, 2002.** Iron reduction and changes in cation exchange capacity in intermittently waterlogged soil. European Journal of Soil Science 53, 175–183.

- Fernández R, Cuevas J, Mäder U K, 2009a.** Modelling concrete interaction with a bentonite barrier. *European Journal of Mineralogy* 21, 177–191.
- Fernández R, Mäder U K, Rodríguez M, Vigil De La Villa R, Cuevas J, 2009b.** Alteration of compacted bentonite by diffusion of highly alkaline solutions. *European Journal of Mineralogy* 21, 725–735.
- Ferris F G, Konhauser K O, Lyuvén B, Pedersen K, 1999.** Accumulation of metals by bacteriogenic iron oxides in a subterranean environment. *Geomicrobiology Journal* 16, 181–192.
- Fredlund D G, Rahardjo H, 1993.** Soil mechanics for unsaturated soils. New York: Wiley.
- Fujita T, Sugiyama D, Swanton S W, Myatt B J, 2003.** Observation and characterization of colloids derived from leached cement hydrates. *Journal of Contaminant Hydrology* 61, 3–16.
- Gaboreau S, Prêt D, Tinseau E, Claret F, Pellegrini D, Stammose D, 2011.** 15 years of *in situ* cement–argillite interaction from Tournemire URL: characterisation of the multi-scale spatial heterogeneities of pore space evolution. *Applied Geochemistry* 26, 2159–2171.
- Galíndez J M, Molinero J, 2010.** On the relevance of electrochemical diffusion for the modelling of degradation of cementitious materials. *Cement and Concrete Composites* 32, 351–359.
- García-García S, Wold S, Jonsson M, 2009.** Effects of temperature on the stability of colloidal montmorillonite particles at different pH and ionic strength. *Applied Clay Science* 43, 21–26.
- Gaucher E, Tournassat C, Nowak C, 2005.** Modelling the geochemical evolution of the multi-barrier system of the Silo of the SFR repository. Final report. SKB R-05-80, Svensk Kärnbränslehantering AB.
- Gimmi T, Kosakowski G, 2011.** How mobile are sorbed cations in clays and clay rocks? *Environmental Science & Technology* 45, 1443–1449.
- Glasser F P, 1993.** Chemistry of cement-solidified waste forms. In Spence R D (ed). *Chemistry and microstructure of solidified waste forms*. Boca Raton, FL: Lewis, 1–40.
- Glasser F P, Matschei T, 2007.** Interactions between Portland cement and carbon dioxide. In *Proceedings of the 12th International Congress on the Chemistry of Cement*, Montreal, Canada, 8–13 July 2007.
- Glasser F P, Angus M J, McCulloch C E, Macphee D, Rahman A A, 1985.** The chemical environments in cements. In Jantzen C M (ed). *Scientific basis for nuclear waste management VIII: symposium held in Boston, Massachusetts, USA, 26–29 November 1984*. Pittsburgh, PA: Materials Research Society. (Materials Research Society Symposium Proceedings 44), 849–858.
- Glasser F P, Kindness A, Stronach S A, 1999.** Stability and solubility in AF_m phases: Part I. Chloride, sulfate and hydroxide. *Cement and Concrete Research* 29, 861–866.
- Goldstein T P, Aizenshtat Z, 1994.** Thermochemical sulfate reduction: a review. *Journal of Thermal Analysis* 42, 241–290.
- Gorbunova O A, Barinov A S, 2011.** Microbiological evaluation of the condition of cement compounds with radioactive wastes after long-term storage in near-surface repositories. *Radiochemistry* 54, 198–204.
- Goudarzi R, Johannesson L-E, Börgesson L, 2005.** Äspö Hard Rock Laboratory. Backfill and plug test. Sensors data report (Period 990601–050101). Report No:10. SKB IPR-05-12, Svensk Kärnbränslehantering AB.
- Grandia F, Galíndez J-M, Arcos D, Molinero J, 2010.** Quantitative modelling of the degradation processes of cement grout. Project CEMMOD. SKB TR-10-25, Svensk Kärnbränslehantering AB.
- Grütter A, von Gunten H R, Kohler M, Rössler, 1990.** Sorption, desorption and exchange of cesium on glaciofluvial deposits. *Radiochimica Acta* 50, 177–184.
- Gu J-D, Ford T E, Mitchell R, 2011.** Microbiological corrosion of concrete. In Revie, R W, Uhlig H H (eds). *Uhlig's corrosion handbook*. 3rd ed. Hoboken, NJ: Wiley, 451–460.

- Guillaumont R, Fanghänel J, Neck V, Fuger J, Palmer D A, Grenthe I, Rand M H, 2003.** Chemical thermodynamics. Vol 5. Update on the chemical thermodynamics of uranium, neptunium, plutonium, americium and technetium. Amsterdam: Elsevier.
- Guldbrand L, Jönsson B, Wennerström H, Linse P, 1984.** Electrical double-layer forces. A Monte Carlo study. *Journal of Chemical Physics* 80, 2221–2228.
- Gunnarsson D, Börgesson L, Hökmark H, Johannesson L-E, Sandén T, 2001.** Äspö Hard Rock Laboratory. Report on the installation of the Backfill and Plug Test. SKB IPR-01-17, Svensk Kärnbränslehantering AB.
- Haga K, Shibata M, Hironaga M, Tanaka S, Nagasaki S, 2002.** Silicate anion structural change in calcium silicate hydrate gel on dissolution of hydrated cement. *Journal of Nuclear Science and Technology* 39, 540–547.
- Hakanen M, Ervanne H, 2006.** The influence of organic cement additives on radionuclide mobility: a literature survey. Posiva Working Report 2006-06, Posiva Oy, Finland.
- Hallbeck L, Pedersen K, 2008.** Explorative analysis of microbes, colloids and gases. SDM-Site Forsmark. SKB R-08-85, Svensk Kärnbränslehantering AB.
- Hammarklint T, 2011.** Svenska havsvattenståndsserier – En klimatindikator. Norrköping: Sveriges Meteorologiska och Hydrologiska Institut (SMHI). (In Swedish.)
- Hansbo S, 1960.** Consolidation of clay, with special reference to influence of vertical drains: a study made in connection with full-scale investigations at Skå-Edeby. PhD thesis. Chalmers University of Technology, Sweden.
- Hansbo S, 1975.** Jordmateriallära. Stockholm: AWE/Geber.
- Hetzel F, Doner H E, 1993.** Some colloidal properties of beidellite: comparison with low and high charge montmorillonite. *Clays and Clay Minerals* 41, 453–460.
- Hidalgo A, Petit S, Domingo C, Alonso C, Andrade C, 2007.** Microstructural characterization of leaching effects in cement pastes due to neutralisation of their alkaline nature: Part I: Portland cement pastes. *Cement and Concrete Research* 37, 63–70.
- Holmboe M, Wold S, Jonsson M, 2010.** Colloid diffusion in compacted bentonite: microstructural constraints. *Clays and Clay Minerals* 58, 532–541.
- Holmén J G, Stigsson M, 2001.** Modelling of future hydrogeological conditions at SFR. SKB R-01-02, Svensk Kärnbränslehantering AB.
- Höglund L O, 1992.** Some notes on ettringite formation in cementitious materials; Influence of hydration and thermodynamic constraints for durability. *Cement and Concrete Research* 22, 217–228.
- Höglund L O, 2001.** Project SAFE. Modelling of long-term concrete degradation processes in the Swedish SFR repository. SKB R-01-08, Svensk Kärnbränslehantering AB.
- Höglund L O, 2014.** The impact of concrete degradation on the BMA barrier functions. SKB R-13-40, Svensk Kärnbränslehantering AB.
- Höglund L O, Wiborgh M, Ahrens G, 1997.** Probabilistic modelling of gas transport in a plugged repository in salt rock. In McKinley I G, McCombie C (eds). *Scientific basis for nuclear waste management XXI: symposium held in Davos, Switzerland, 23 September – 3 October 1997*. Warrendale, PA: Materials Research Society. (Materials Research Society Symposium Proceedings 506).
- IUPAC, 2011.** Compendium of chemical terminology, Version 2.3. (The “Gold Book”.) International Union of Pure and Applied Chemistry.
- Johannesson L-E, Börgesson L, Sandén T, 1999.** Äspö Hard Rock Laboratory. Backfill materials based on crushed rock (part 2). Geotechnical properties determined in the laboratory. SKB IPR-99-23, Svensk Kärnbränslehantering AB.
- Justnes H, 2003.** Thaumasite formed by sulfate attack on mortar with limestone filler. *Cement & Concrete Composites* 25, 955–959.

- Karnland O, 1997.** Bentonite swelling pressure in strong NaCl solutions. Correlation between model calculation and experimentally determined data. SKB TR 97-31, Svensk Kärnbränslehantering AB.
- Karnland O, Sandén T, Johannesson L-E, Eriksen T E, Jansson M, Wold S, Pedersen K, Motamedi M, Rosborg B, 2000.** Long term test of buffer material. Final report on the pilot parcels. SKB TR-00-22, Svensk Kärnbränslehantering AB.
- Karnland O, Muurinen A, Karlsson F, 2005.** Bentonite swelling pressure in NaCl solutions – experimentally determined data and model calculations. In Alonso E, Ledesma A (eds). Advances in understanding engineered clay barriers: proceedings of the International Symposium on Large Scale Field Tests in Granite, Sitges, Barcelona, 12–14 November 2003. London: Taylor & Francis Group, 241–256.
- Karnland O, Olsson S, Nilsson U, 2006.** Mineralogy and sealing properties of various bentonites and smectite-rich clay material. SKB TR-06-30, Svensk Kärnbränslehantering AB.
- Karnland O, Olsson S, Dueck A, Birgersson M, Nilsson U, Hernan-Håkansson T, Pedersen K, Nilsson S, Eriksen T E, Rosborg B, 2009.** Long term test of buffer material at the Äspö Hard Rock Laboratory, LOT project. Final report on the A2 test parcel. SKB TR-09-29, Svensk Kärnbränslehantering AB.
- Kato H, Muroi M, Yamada N, Ishida H, Sato H, 1995.** Estimation of effective diffusivity in compacted bentonite. In Murakami T, Ewing R C (eds). Scientific basis for nuclear waste management XVIII: symposium held in Kyoto, Japan, 23–27 October 1994. Pittsburgh, PA: Materials Research Society. (Materials Research Society Symposium Proceedings 353), 277–284.
- Keepax R E, Jones D M, Pepper S E, Bryan N D, 2002.** The effects of humic substances on radioactivity in the environment. In Keith-Roach M J, Livens F R (eds). Interactions of microorganisms with radionuclides. Oxford: Elsevier.
- Keith-Roach M J, 2008.** The speciation, stability, solubility and biodegradation of organic co-contaminant radionuclide complexes: a review. *Science of the Total Environment* 396, 1–11.
- Kessler M A, Werner B T, 2003.** Self-organization of sorted patterned ground. *Science* 299, 380–383.
- Kienzler B, Vejmelka P, Römer J, Schild D, 2009.** Actinide migration in fractures of granite host rock: laboratory and in situ investigations. *Nuclear Technol.* 165, 223-240. Koskinen A, Hakanen M, Lindberg A, 1988. Sorption experiments at oxic and anoxic conditions. Report YJT-88-05, Nuclear waste commission of Finnish power companies, Helsinki, Finland.
- Kim J, Dong H, Seabaugh J, Newell S W, Eberl D D, 2004.** Role of microbes in the smectite-to-illite reaction, *Science* 303, 830–832.
- Kjellander R, Marčelja S, 1984.** Correlation and image charge effects in electric double layers. *Chemical Physical Letters* 112, 49–53.
- Kjellander R, Marčelja S, Quirk J P, 1988.** Attractive double-layer interactions between calcium clay particles. *Journal of Colloid and Interface Science* 126, 194–211.
- Kostka J E, Dalton D D, Skelton H, Dollhopf S, Stucki J W, 2002.** Growth of iron(III)-reducing bacteria on clay minerals as the sole electron acceptor and comparison of growth yields on a variety of oxidised iron forms, *Applied and Environmental Microbiology* 68, 6256–6262.
- Krane K S, 1987.** Introductory nuclear physics. New York: Wiley.
- Kulik D A, Kersten M, 2002.** Aqueous solubility diagrams for cementitious waste stabilization systems. 4. A carbonation model for Zn-doped calcium silicate hydrate by Gibbs energy minimization. *Environmental Science & Technology* 36, 2926–2931.
- Kurosawa S, Yui M, Yoshikawa H, 1997.** Experimental study of colloid filtration by compacted bentonite. In Gray W J, Triay I R (eds). Scientific basis for nuclear waste management XX: symposium held in Boston, Massachusetts, 2–6 December 1996. Pittsburgh, PA: Materials Research Society. (Materials Research Society Symposium Proceedings 465), 963–970.

- Laaksoharju M (ed), 2003.** Äspö Hard Rock Laboratory. Status report of the colloid investigation conducted at the Äspö HRL during the years 2000–2003. SKB IPR-03-38, Svensk Kärnbränslehantering AB.
- Laaksoharju M, Wold S, 2005.** The colloid investigations conducted at the Äspö Hard Rock Laboratory during 2000–2004. SKB TR-05-20, Svensk Kärnbränslehantering AB.
- Laaksoharju M, Degeldre C, Skårman C, 1995.** Studies of colloids and their importance for repository performance assessment. SKB TR 95-24, Svensk Kärnbränslehantering AB.
- Lagaly G, Ziesmer S, 2003.** Colloid chemistry of clay minerals: the coagulation of montmorillonite dispersions. *Advances in Colloid and Interface Science* 100–102, 105–128.
- Lagerblad B, 2001.** Leaching performance of concrete based on studies of samples from old concrete constructions. SKB TR-01-27, Svensk Kärnbränslehantering AB.
- Lagerblad B, Trägårdh J, 1994.** Conceptual model for concrete long time degradation in a deep nuclear waste repository. SKB TR 95-21, Svensk Kärnbränslehantering AB.
- Le Bell J C, 1978.** Colloid chemical aspects of the “confined bentonite concept”. KBS TR 97, Svensk Kärnbränsleförsörjning AB.
- Lee J-S, Lee K C, Chang Y-H, Hong S G, Oh H W, Pyun Y-R, Bae K S, 2002.** *Paenibacillus daejeonensis* sp. nov., a novel alkaliphilic bacterium from soil. *International Journal of Systematic and Evolutionary Microbiology* 52, 2107–2111.
- Lerman A, 1988.** Geochemical processes: water and sediment environments. New York: Robert E. Krieger Publishing Company.
- Lindgren M, Pettersson M, Karlsson S, Moreno L, 2001.** Project SAFE. Radionuclide release and dose from the SFR repository. SKB R-01-18, Svensk Kärnbränslehantering AB.
- Little B J, Jason S L, 2007.** Microbially influenced corrosion. Hoboken, NJ: Wiley.
- Liu L, Moreno L, Neretnieks I, 2009.** A dynamic force balance model for colloidal expansion and its DLVO-based application. *Langmuir* 25, 679–687.
- Lu N, Reimus P W, Parker G R, Conca J L, Triay I R, 2003.** Sorption kinetics and impact of temperature, ionic strength and colloid concentration on the adsorption of plutonium-239 by inorganic colloids. *Radiochimica Acta* 91, 713–720.
- Lydmark S, 2010.** Äspö Hard Rock Laboratory. Prototype Repository. Analyses of micro-organisms, gases, and water chemistry in buffer and backfill, 2009. SKB IPR-10-04, Svensk Kärnbränslehantering AB.
- Malhotra V M, 2011.** Durability of concrete. In Revie, R W, Uhlig H H (eds). *Uhlig’s corrosion handbook*. 3rd ed. Hoboken, NJ: Wiley, 439–449.
- Maltais Y, Samson E, Marchand J, 2004.** Predicting the durability of Portland cement systems in aggressive environments – laboratory validation. *Cement and Concrete Research* 34, 1579–1589.
- Marchand J, Bentz D P, Samson E, Maltais Y, 2001.** Influence of calcium hydroxide dissolution on the transport properties of hydrated cement systems. In *Materials Science of Concrete; proceedings of the Workshop on the Role of Calcium Hydroxide in Concrete*, Holmes Beach, Anna Maria Island, Florida, 2001. Westerville, OH: American Ceramic Society, 113–129.
- Marchand J, Samson E, Maltais Y, Beaudoin J J, 2002.** Theoretical analysis of the effect of weak sodium sulfate solutions on the durability of concrete. *Cement and Concrete Composites* 24, 317–329.
- Marty N C M, Tournassat C, Burnol A, Giffaut E, Gaucher E C, 2009.** Influence of reaction kinetics and mesh refinement on the numerical modelling of concrete/clay interactions. *Journal of Hydrology* 364, 58–72.
- Masurat P, Eriksson S, Pedersen K, 2010a.** Evidence of indigenous sulphate-reducing bacteria in commercial Wyoming bentonite MX-80. *Applied Clay Science* 47, 51–57.
- Masurat P, Eriksson S, Pedersen K, 2010b.** Microbial sulphide production in compacted Wyoming bentonite MX-80 under in situ conditions relevant to a repository for high-level radioactive waste. *Applied Clay Science* 47, 58–64.

- Miller W, Alexander R, Chapman N, McKinley I, Smellie J, 2000.** Geological disposal of radioactive wastes and natural analogues: lessons from nature and archaeology. Oxford: Pergamon.
- Moranville M, Kamali S, Guillon E, 2004.** Physicochemical equilibria of cement-based materials in aggressive environments – experiment and modelling. *Cement and Concrete Research* 34, 1569–1578.
- Moreno L, Skagius K, Södergren S, Wiborgh M, 2001.** Project SAFE. Gas related processes in SFR. SKB R-01-11, Svensk Kärnbränslehantering AB.
- Muurinen A, 1994.** Diffusion of anions and cations in compacted sodium bentonite. Espoo: Technical Research Centre of Finland. (VTT Publications 168)
- Muurinen A, Carlsson T, 2007.** Eh and pH in compacted MX-80 bentonite. NF-PRO RTD2, Deliverable 2.2.14, European Commission.
- Möller G, Petersons N, Samuelson P, 1981.** “Betonghandboken”, Material. Svensk Byggtjänst, Stockholm. (In Swedish.)
- Möschner G, 2007.** A thermodynamic approach to cement hydration: the role of retarding admixtures and Fe-minerals during the hydration of cements. PhD thesis. ETH Zürich.
- National Research Council (US), 2007.** Assessment of the performance of engineered waste containment barriers. Washington, DC: National Academics Press.
- NEA, 2005.** NEA Sorption Project Phase II. Interpretation and prediction of radionuclide sorption onto substrates relevant for radioactive waste disposal using thermodynamic sorption models. Paris: OECD/NEA.
- NEA, 2012.** NEA Sorption Project Phase III. Thermodynamic sorption modelling in support of radioactive waste disposal safety cases. Paris: OECD/NEA.
- Neretnieks I, Liu L, Moreno L, 2009.** Mechanisms and models for bentonite erosion. SKB TR-09-35, Svensk Kärnbränslehantering AB.
- Neuzil C E, 2000.** Osmotic generation of “anomalous” fluid pressures in geological environments. *Nature* 403, 182–184.
- Nilsson A-C, 2007.** Grundvattenkemi i SFR: Resultat av provtagning och analyser under år 2006. Geosigma AB, 2007-03-15.
- Nirex, 2003.** Generic repository studies: Generic post-closure Performance Assessment. Nirex Report N/080, Nirex, UK.
- Norris S, 2008.** PAMINA Performance Assessment Methodologies in Application to Guide the Development of the Safety Case (Contract Number: FP6-036404). Deliverable D2.2.B.2. Uncertainties Associated with Modelling the Consequences of Gas 26/03/2008.
- Norris S, 2009.** Summary of gas generation and migration current state-of-the-art. FORGE D1.2-R – DRAFT, July 2009, Fate of repository gases, Euratom 7th Framework project.
- Ochs M, Lothenbach B, Wanner H, Sato H, Yui M, 2001.** An integrated sorption–diffusion model for the calculation of consistent distribution and diffusion coefficients in compacted bentonite. *Journal of Contaminant Hydrology* 47, 283–296.
- Ochs M, Lothenbach B, Shibata M, Sato H, Yui M, 2003.** Sensitivity analysis of radionuclide migration in compacted bentonite: a mechanistic model approach. *Journal of Contaminant Hydrology* 61, 313–328.
- Ochs M, Talerico C, 2004.** SR-Can. Data and uncertainty assessment. Migration parameters for the bentonite buffer in the KBS-3 concept. SKB TR-04-18, Svensk Kärnbränslehantering AB.
- O’Day P A, Brown G E, Parks G A, 1994.** X-ray absorption spectroscopy of cobalt(II) multinuclear surface complexes and surface precipitates on kaolinite. *Journal of Colloid and Interface Science* 165, 269–289.
- Parkhurst D L, Appelo C A J, 1999.** User’s guide to PHREEQC (version 2): a computer program for speciation, batch-reaction, one-dimensional transport, and inverse geochemical calculations. Water-Resources Investigations Report 99-4259, U.S. Geological Survey, Denver, Colorado.

- Parsons I, 2010.** Nice day out for a material scientist. *Elements* 6, 271.
- Pedersen K, 2001.** Project SAFE. Microbial features, events and processes in the Swedish final repository for low- and intermediate-level radioactive waste. SKB R-01-05, Svensk Kärnbränslehantering AB.
- Pedersen K, Motamedi M, Karnland O, Sandén T, 2000a.** Cultivability of microorganisms introduced into a compacted bentonite clay buffer under high-level radioactive waste repository conditions. *Engineering Geology* 58, 149–161.
- Pedersen K, Motamedi M, Karnland O, Sandén T, 2000b.** Mixing and sulphate-reducing activity of bacteria in swelling compacted bentonite clay under high-level radioactive waste repository conditions. *Journal of Applied Microbiology* 89, 1038–1047.
- Pedersen K, Kennedy C, Nederfeldt K-G, Bergelin A, 2004a.** Äspö Hard Rock Laboratory. Prototype repository. Chemical measurements in buffer and backfill; sampling and analysis of gases. SKB IPR-04-26, Svensk Kärnbränslehantering AB.
- Pedersen K, Nilsson E, Arlinger J, Hallbeck L, O'Neill A, 2004b.** Distribution, diversity and activity of microorganisms in the hyper-alkaline spring waters of Maqarin in Jordan. *Extremophiles* 8, 151–164.
- Pedersen K, Arlinger J, Eriksson S, Hallbeck M, Johansson J, Jägevall S, Karlsson L, 2008.** Microbiology of Olkiluoto groundwater. Results and interpretations 2007. Posiva Working Report 2008-34, Posiva Oy, Finland.
- Pérez del Villar L, Delgado A, Reyes E, Pelayo M, Fernández-Soler J M, Cózar J S, Tsige M, Quejido A J, 2005.** Thermochemically induced transformations in Al-smectites: a Spanish natural analogue of the bentonite barrier behaviour in a radwaste disposal. *Applied Geochemistry* 20, 2252–2282.
- Perkins R B, Palmer C D, 1999.** Solubility of ettringite ($\text{Ca}_6(\text{Al}(\text{OH})_6)_2(\text{SO}_4)_3 \cdot 26\text{H}_2\text{O}$) at 5–75°C. *Geochimica et Cosmochimica Acta* 63, 1969–1980.
- Petsev D N, Starov V M, Ivanov I B, 1993.** Concentrated dispersions of charged colloidal particles: sedimentation, ultrafiltration. and diffusion. *Colloids and Surfaces A: Physicochemical and Engineering Aspects* 81, 65–81.
- Pfingsten W, 2001.** Indications for self-sealing of a cementitious L&ILW repository. PSI Bericht 01-09, Paul Scherrer Institute, Switzerland, Nagra Technical Report NTB 01-05, Nagra, Switzerland.
- Pfingsten W, 2002.** Experimental and modelling indications for self-sealing of a cementitious low- and intermediate-level waste repository by calcite precipitation. *Nuclear Technology* 140, 63–82.
- Philip J R, de Vries D A, 1957.** Moisture movement in porous materials under temperature gradients. *Transactions, American Geophysical Union* 38, 222–232.
- Pointeau I, Reiller P, Macé N, Landesman C, Coreau N, 2006.** Measurement and modelling of the surface potential evolution of hydrated cement pastes as a function of degradation. *Journal of Colloid and Interface Science* 300, 33–44.
- Popp T, 2009.** FORGE D3.1-R (WP 3.3), State of the art report on gas transport through interfaces. Fate of repository gases, Euratom 7th Framework project: FORGE 2009.
- Pruess K, 1987.** TOUGH User's guide, Report NUREG/CR-4645, Nuclear Regulatory Commission (also Report LBL-20700, Lawrence Berkeley National Laboratory, Berkeley, California).
- Pruess K, 1991.** TOUGH2 – A general purpose numerical simulator for multiphase fluid and heat flow. Report LBL-29400, Lawrence Berkeley National Laboratory, Berkeley, California.
- Pusch R, 1977.** Influence of cementation on the deformation properties of bentonite/quartz buffer substance. KBS TR 14, Svensk Kärnbränsleförsörjning AB.
- Pusch R, 2003.** Design, construction and performance of the clay-based isolation of the SFR silo. SKB R-03-30, Svensk Kärnbränslehantering AB.
- Pusch R, Hökmark H, 1987.** Megaparameterstudie av gastransport genom SFR-buffertar. SKB SFR 87-06, Svensk Kärnbränslehantering AB.

- Pusch R, Karnland O, 1988.** Geological evidence of smectite longevity. The Sardinian and Gotland cases. SKB TR 88-26, Svensk Kärnbränslehantering AB.
- Pusch R, Karnland O, Lajudie A, Decarreau A, 1993.** MX 80 clay exposed to high temperatures and gamma radiation. SKB TR 93-03, Svensk Kärnbränslehantering AB.
- Pusch R, Takase H, Benbow S, 1998.** Chemical processes causing cementation in heat-affected smectite – the Kinnekulle bentonite. SKB TR-98-25, Svensk Kärnbränslehantering AB.
- Reguera G, McCarthy K D, Mehta T, Nicoll J S, Tuominen M T, Lovley D R, 2005.** Extracellular electron transfer via microbial nanowires. *Nature* 435, 1098–1101.
- Resele G, Illi H, 1992.** Modelling of gas release from a nuclear waste repository. In *Gas Generation and Release from Radioactive Waste Repositories, Proceedings of the NEA Workshop, Aix-en-Provence, France, 23–26 September 1991*. Paris: OECD/NEA, 378–389.
- Richardson I G, 2004.** Tobermorite/jennite- and tobermorite/calcium hydroxide-based models for the structure of C-S-H: applicability to hardened pastes of tricalcium silicate, β -dicalcium silicate, Portland cement, and blends of Portland cement with blast-furnace slag, metakaolin, or silica fume. *Cement and Concrete Research* 34, 1733–1777.
- Rodwell W R, Nash P J, 1992.** Modelling of far-field gas migration from a deep radioactive waste repository. In *Gas Generation and Release from Radioactive Waste Repositories, Proceedings of the NEA Workshop, Aix-en-Provence, France, 23–26 September 1991*. Paris: OECD/NEA, 391–403.
- Rodwell W R, Harris A W, Horseman S T, Lalieux P, Müller W, Ortiz Amaya L, Pruess K, 1999.** Gas migration and two-phase flow through engineered and geological barriers for a deep repository for radioactive waste: a joint EC/NEA status report. EUR 19122 EN, European Commission.
- Rogers R D, Knight J J, Cheeseman C R, Wolfram J H, Idachaba M, Nyavor K, Eigebor N O, 2003.** Development of test methods for assessing microbial influenced degradation of cement-solidified radioactive and industrial waste. *Cement and Concrete Research* 33, 2069–2076.
- Rowell D L, Dillon P J, 1972.** Migration and aggregation of Na and Ca clays by the freezing of dispersed and flocculated suspension. *Journal of Soil Science* 23, 442–447.
- Saito H, Deguchi A, 2000.** Leaching tests on different mortars using accelerated electrochemical method. *Cement and Concrete Research* 30, 1815–1825.
- Sandén T, Börgesson L, 2008.** Deep repository-engineered barrier system. Piping and erosion in tunnel backfill. Laboratory tests to understand the processes during early water uptake. SKB R-06-72, Svensk Kärnbränslehantering AB.
- Sandén T, Börgesson L, 2010.** Early effects of water inflow into a deposition hole. Laboratory test results. SKB R-10-70, Svensk Kärnbränslehantering AB.
- Sandén T, Börgesson L, Dueck A, Goudarzi R, Lönnqvist M, 2008.** Deep repository-engineered barrier system. Erosion and sealing processes in tunnel backfill materials investigated in laboratory. SKB R-08-135, Svensk Kärnbränslehantering AB.
- Sandén T, Börgesson L, Dueck A, Goudarzi R, Lönnqvist M, Nilsson U, Åkesson M, 2010.** KBS-3H. Description of buffer tests in 2005–2007. Results of laboratory tests. SKB R-08-40, Svensk Kärnbränslehantering AB.
- Sato H, Yui M, Hideki Y, 1995.** Diffusion behaviour for Se and Zr in sodium-bentonite. In Murakami T, Ewing R C (eds). *Scientific basis for nuclear waste management XVIII: symposium held in Kyoto, Japan, 23–27 October 1994*. Pittsburgh, PA: Materials Research Society. (Materials Research Society Symposium Proceedings 353), 269–276.
- Savage D, 2011.** A review of analogues of alkaline alteration with regard to long-term barrier performance. *Mineralogical Magazine* 75, 2401–2418.
- Savage D, Soler J M, Yamaguchi K, Walker C, Honda A, Inagaki M, Watson C, Wilson J, Benbow S, Gaus I, Rueedi J, 2011.** A comparative study of the modelling of cement hydration and cement-rock laboratory experiments. *Applied Geochemistry* 26, 1138–1152.

Scheidegger A M, Sparks D L, 1996. Kinetics of the formation and the dissolution of nickel surface precipitates on pyrophyllite. *Chemical Geology* 132, 157–164.

Schindler P W, Stumm W, 1987. The surface chemistry of oxides, hydroxides and oxide minerals. In Stumm W (ed). *Aquatic surface chemistry: chemical processes at the particle-water interface*. New York: Wiley, 83–110.

Shimura T, Fujiwara A, Vomvoris S, Marschall P, Lanyon G W, Ando K, Yamamoto S, 2006. Large-scale gas migration test at Grimsel Test Site. In *Proceedings of the 11th International high-level radioactive waste management conference, Las Vegas, 30 April – 4 May 2006*. New York: American Nuclear Society, 784–791.

Sidborn M, Marsic N, Crawford J, Joyce S, Hartley L, Idiart A, de Vries L M, Maia F, Molinero J, Svensson U, Vidstrand P, Alexander R, 2014. Potential alkaline conditions for deposition holes of a repository in Forsmark as a consequence of OPC grouting. SKB R-12-17, Svensk Kärnbränslehantering AB.

SKB, 1999a. Deep repository for spent nuclear fuel. SR 97 – Post-closure safety. Main report – Vol. I, Vol. II and Summary. SKB TR-99-06, Svensk Kärnbränslehantering AB.

SKB, 1999b. Deep repository for long-lived low- and intermediate level waste. Preliminary safety assessment. SKB TR-99-28, Svensk Kärnbränslehantering AB.

SKB, 2001. Project SAFE. Scenario and system analysis. SKB R-01-13, Svensk Kärnbränslehantering AB.

SKB, 2006. Buffer and backfill process report for the safety assessment SR-Can. SKB TR-06-18, Svensk Kärnbränslehantering AB.

SKB, 2008a. Site description of Forsmark at completion of the site investigation phase. SDM-Site Forsmark. SKB TR-08-05, Svensk Kärnbränslehantering AB.

SKB, 2008b. Safety analysis SFR 1. Long-term safety. SKB R-08-130, Svensk Kärnbränslehantering AB.

SKB 2008c. Project SFR 1 SAR-08. Update of priority of FEPs from Project SAFE. SKB R-08-12, Svensk Kärnbränslehantering AB.

SKB, 2010a. Buffer, backfill and closure process report for the safety assessment SR-Site. SKB TR-10-47, Svensk Kärnbränslehantering AB.

SKB, 2010b. RD&D Programme 2010. Programme for research, development and demonstration of methods for the management and disposal of nuclear waste. SKB TR-10-63, Svensk Kärnbränslehantering AB.

SKB, 2010c. Fuel and canister process report for the safety assessment SR-Site. SKB TR-10-46, Svensk Kärnbränslehantering AB.

SKB, 2011. Long-term safety for the final repository for spent nuclear fuel at Forsmark. Main report of the SR-Site project. SKB TR-11-01, Svensk Kärnbränslehantering AB.

Sliwiska-Bartkowiak M, Gras J, Sikorski R, Radhakrishnan R, Gelb L, Gubbins K E, 1999. Phase transitions in pores: experimental and simulation studies of melting and freezing. *Langmuir* 15, 6060–6069.

Small J, Nykyri M, Helin M, Hovi U, Sarlin T, Itävaara M, 2008. Experimental and modelling investigations of the biogeochemistry of gas production from low and intermediate level radioactive waste. *Applied Geochemistry* 23, 1383–1418.

Smart N R, Blackwood D J, Werme L, 2001. The anaerobic corrosion of carbon steel and cast iron in artificial groundwaters. SKB TR-01-22, Svensk Kärnbränslehantering AB.

Smellie J (ed), 1998. Maqarin natural analogue study: Phase III. SKB TR-98-04, Svensk Kärnbränslehantering AB.

Smellie J, Karlsson F, 1996. A reappraisal of some Cigar Lake issues of importance to performance assessment. SKB TR 96-08, Svensk Kärnbränslehantering AB.

- Smith P A, Degueudre C, 1993.** Colloid-facilitated transport of radionuclides through fractured media. *Journal of Contaminant Hydrology* 13, 143–166.
- Soler J M, 2007.** Thermodynamic description of the solubility of C-S-H gels in hydrated Portland cement – literature review. Posiva Working Report 2007-88, Posiva Oy, Finland.
- Sposito G, 1981.** The thermodynamics of soil solutions. Oxford: Clarendon.
- Sposito G, 1984.** The surface chemistry of soils. New York: Oxford University Press.
- Stroes-Gascoyne S, Pedersen K, Haveman S A, Dekeyser K, Arlinger J, Daumas S, Ekendahl S, Hallbeck L, Hamon C J, Jahromi N, Delaney T-L, 1997.** Occurrence and identification of micro-organisms in compacted clay-based buffer material designed for use in a nuclear fuel waste disposal vault. *Canadian Journal of Microbiology* 43, 1133–1146.
- Stronach S A, Glasser F P, 1997.** Modelling the impact of abundant geochemical components on phase stability and solubility of the CaO–SiO₂–H₂O system at 25°C: Na⁺, K⁺, SO₄²⁻, Cl⁻ and CO₃²⁻. *Advances in Cement Research* 9, 167–181.
- Stumm W, 1992.** Chemistry of the solid-water interface: processes at the mineral-water and particle-water interface in natural systems. New York: Wiley.
- Stumm W, Morgan J J, 1996.** Aquatic chemistry: chemical equilibria and rates in natural waters. 3rd ed. New York: Wiley.
- Sugiyama D, Fujita T, 2005.** A thermodynamic model of dissolution and precipitation of calcium silicate hydrates. *Cement and Concrete Research* 36, 227–237.
- Svensson D, Dueck A, Olsson S, Sandén T, Lydmark S, Jägevall S, Pedersen K, Hansen S, 2011.** Alternative buffer material. Status of the ongoing laboratory investigation of reference materials and test package 1. SKB TR-11-06, Svensk Kärnbränslehantering AB.
- Tachi Y, Yotsuji K, Seida Y, Yui M, 2009.** Diffusion of cesium and iodine in compacted sodium montmorillonite under different saline conditions. In Burakov B E, Aloy A S (eds). Scientific basis for nuclear waste management XXXIII. Warrendale, PA: Materials Research Society. (Materials Research Society Symposium Proceedings 1193), 545–551.
- Tachi Y, Nakazawa N, Ochs M, Yotsuji K, Suyama T, Seida Y, Yamada K, Yui M, 2010.** Diffusion and sorption of neptunium(V) in compacted montmorillonite: effect of carbonate and salinity. *Radiochimica Acta* 98, 711–718.
- Takai K, Moser D P, Onstott T C, Spoelstra N, Piffner S M, Dohnalkova A, Fredrickson J K, 2001.** *Alkaliphilus transvaalensis* gen. nov., sp. nov., an extremely alkaliphilic bacterium isolated from a deep South African gold mine. *International Journal of Systematic and Evolutionary Microbiology* 51, 1245–1256.
- Taylor H F W, 1990.** Cement chemistry. London: Academic Press.
- Techer I, Bartier D, Boulvais P, Tinsseau E, Suchorski K, Cabrera J, Dauzères A, 2012.** Tracing interactions between natural argillites and hyper-alkaline fluids from engineered cement paste and concrete: chemical and isotopic monitoring of a 15-years old deep-disposal analogue. *Applied Geochemistry* 27, 1384–1402.
- Thomson G, Herben M, Lloyd P, Rose D, Smith C, Barraclough I, 2008a.** Implementation of Project Safe in Amber. Verification study for SFR 1 SAR-08. SKB R-08-13, Svensk Kärnbränslehantering AB.
- Thomson G, Miller A, Smith G, Jackson D, 2008b.** Radionuclide release calculations for SAR-08. SKB R-08-14, Svensk Kärnbränslehantering AB.
- Tits J, Iijima K, Wieland E, Kamei G, 2006.** The uptake of radium by calcium silicate hydrates and hardened cement paste. *Radiochimica Acta* 94, 637–643.
- Tombács E, Szekeres M, 2004.** Colloidal behaviour of aqueous montmorillonite suspensions: the specific role of pH in the presence of indifferent electrolytes. *Applied Clay Science* 27, 75–94.
- Trotignon L, Peycelon H, Bourbon X, 2006.** Comparison of performance of concrete barriers in a clayey geological medium. *Physics and Chemistry of the Earth, Parts A/B/C* 31, 610–617.

- Tullborg E-L, Smellie J, Nilsson A-C, Gimeno M J, Auqué L F, Brüchert V, Molinero J, 2010.** SR-Site – sulphide content in the groundwater at Forsmark. SKB TR-10-39, Svensk Kärnbränslehantering AB.
- van Loon G W, Duffy S J, 2000.** Environmental chemistry: a global perspective. Oxford: Oxford University Press.
- van Olphen H, 1963.** An introduction to clay colloid chemistry. New York: Wiley Interscience.
- van Olphen H, 1991.** An introduction to clay colloid chemistry: for clay technologists, geologists and soil scientists. 2nd ed. New York: Wiley.
- Verburg K, Baveye P, 1994.** Hysteresis in the binary exchange of cations on 2:1 clay minerals: a critical review. *Clays and Clay Minerals* 42, 207–220.
- Vuorinen U, Lehtikoinen J, Luukkonen A, Ervanne H, 2006.** Effects of salinity and high pH on crushed rock and bentonite– Experimental work and modelling. Posiva 2006-01, Posiva Oy, Finland.
- Walker C S, 2003.** Characterisation and solubility behaviour of synthetic calcium silicate hydrates. PhD thesis. Earth Sciences, University of Bristol, UK.
- Walker C S, Savage D, Tyrer M, Ragnarsdottir K V, 2007.** Non-ideal solid solution aqueous solution modelling of synthetic calcium silicate hydrate. *Cement and Concrete Research* 37, 502–511.
- Wanner H, Wersin P, Sierro N, 1992.** Thermodynamic modelling of bentonite–groundwater interaction and implications for near field chemistry in a repository for spent fuel. SKB TR 92-37, Svensk Kärnbränslehantering AB.
- Wanner H, Albinsson Y, Wieland E, 1996.** A thermodynamic surface model for caesium sorption on bentonite. *Fresenius' Journal of Analytical Chemistry* 354, 763–769.
- Wersin P, Curti E, Appelo C A J, 2004.** Modelling bentonite–water interactions at high solid/liquid ratios: swelling and diffuse double layer effects. *Applied Clay Science* 26, 249–257.
- Wersin P, Birgersson M, Olsson S, Karnland O, Snellman M, 2008.** Impact of corrosion-derived iron on the bentonite buffer within the KBS-3H disposal concept. The Olkiluoto site as case study. SKB R-08-34, Svensk Kärnbränslehantering AB.
- Wetton P D, Pearce J M, Alexander W R, Milodowski A E, Reeder S, Wragg J, Salameh E, 1998.** The production of colloids at the cement/host rock interface. In Smellie J A T (ed) *Maqarin natural analogue study: Phase III, Volume I*. SKB TR-98-04, Svensk Kärnbränslehantering AB, 333–365.
- Wiborgh M, Höglund L O, Pers K, 1986.** Gas formation in a L/ILW repository and gas transport in the host rock. Nagra Technical Report NTB 85-17, Nagra, Switzerland.
- Wiborgh M, Bengtsson A, Pers K, Lindgren M, 1987.** Radionuclide release from the near field in SFR. SKB SFR 87-10, Svensk Kärnbränslehantering AB.
- Widestrand H, Byegård J, Selnert E, Skålberg M, Höglund S, Gustafsson E, 2010.** Long term sorption diffusion experiment (LTDE-SD). Supporting laboratory program – sorption diffusion experiments and rock material characterisation. With supplement of adsorption studies on intact rock samples from the Forsmark and Laxemar site investigations. SKB R-10-66, Svensk Kärnbränslehantering AB.
- Wieland E, 2001.** Experimental studies on the inventory of cement-derived colloids in the pore water of a cementitious backfill material. A contribution to the understanding of the role in the retardation of radionuclides in the near-field of a repository. Nagra Technical Report NTB 01-02, Nagra, Switzerland.
- Wieland E, Spieler P, 2001.** Colloids in the mortar backfill of a cementitious repository for radioactive waste. *Waste Management* 21, 511–523.
- Wieland E, Tits J, Bradbury M H, 2004.** The potential effect of cementitious colloids on radionuclide mobilization in a repository for radioactive waste. *Applied Geochemistry* 19, 119–135.
- Wold S, 2003.** On diffusion of organic colloids in compacted bentonite. PhD thesis. Royal Institute of Technology, Stockholm, Sweden.

Wold S, 2010. Sorption of prioritized elements on montmorillonite colloids and their potential to transport radionuclides. SKB TR-10-20, Svensk Kärnbränslehantering AB.

Yokozeki K, Watanabe K, Sakata N, Otsuki N, 2004. Modelling of leaching from cementitious materials used in underground environment. *Applied Clay Science* 26, 293–308.

Yu J-W, Neretnieks I, 1997. Diffusion and sorption properties of radionuclides in compacted bentonite. SKB TR 97-12, Svensk Kärnbränslehantering AB.

Yumoto I, 2007. Alkaliphiles. In Gerday C, Glansdorff N (eds). *Physiology and biochemistry of extremophiles*. Washington DC: ASM Press.

Zachara J M, Smith S C, Liu C, Mckinley J P, Serne R J, Gassman P L, 2002. Sorption of Cs⁺ to micaceous subsurface sediments from the Hanford site, USA. *Geochimica et Cosmochimica Acta* 66, 193–211.

Zhang J Z, Buenfield N R, 1997. Presence and possible implications of a membrane potential in concrete exposed to chloride solution. *Cement and Concrete Research* 27, 853–859.

Åkesson M, Kristensson O, Börgeson L, Dueck A, Hernelind J, 2010. THM modelling of buffer, backfill and other system components. Critical processes and scenarios. SKB TR-10-11, Svensk Kärnbränslehantering AB.

Unpublished documents

SKBdoc id, version	Title	Issuer, year
1032170 ver 4.0	Salterns påverkan på betong i SFR. (In Swedish.)	SwedPower, 2004
1358612 ver 1.0	SFR förslutningsplan. (In Swedish.)	SKB, 2014
1417785 ver 1.0	Översiktlig bedömning av konsekvenser för omgivande barriärer i BMA (SFR) till följd av ny behandling och förpackning av indunstarkoncentrat i Forsmark. (In Swedish.)	Kemakta, 2000