

**SKB**

---

**TECHNICAL  
REPORT**

---

**90-33**

**Plan 90  
Cost for management of the  
radioactive waste from nuclear  
power production**

Swedish Nuclear Fuel and Waste Management Co (SKB)

June 1990

---

**SVENSK KÄRNBRÄNSLEHANTERING AB**

*SWEDISH NUCLEAR FUEL AND WASTE MANAGEMENT CO*

BOX 5864 S-102 48 STOCKHOLM

TEL 08-665 28 00 TELEX 13108 SKB S

TELEFAX 08-661 57 19

PLAN 90  
COSTS FOR MANAGEMENT OF THE RADIOACTIVE WASTE FROM  
NUCLEAR POWER PRODUCTION

Swedish Nuclear Fuel and Waste Management Co (SKB)

June 1990

# **PLAN 90**

## **Costs for management of the radioactive waste from nuclear power production**

June 1990

## CONTENTS

	Page
SUMMARY	
ABBREVIATIONS	
1. PREMISES	1
1.1 General	1
1.2 Energy Production and Waste Quantities	2
1.3 Principles of the Waste Management System	4
2. FACILITIES AND SYSTEMS	5
2.1 General	5
2.2 Research, Development, and Demonstration	6
2.3 Transportation System	8
2.4 Central Interim Storage Facility for Spent Nuclear Fuel, CLAB	9
2.5 Encapsulation station for spent fuel, BS	11
2.6 Final Repository for Long-Lived Waste, SFL	13
2.7 Final Repository for Reactor Waste, SFR	15
2.8 Decommissioning of Nuclear Power Plants	18
3. COSTS	19
3.1 General	19
3.2 Calculation Method	20
3.3 Reporting of Future Costs	20
3.4 Previously Incurred Costs	24
3.5 Marginal Costs	25
3.6 Waste Management Fee	26
REFERENCES	27
APPENDICES:	
1. Spent fuel and radioactive waste in Sweden assuming operation of all plants through 2010	
2. Transportation system	
3. Central interim storage facility for spent nuclear fuel, CLAB	
4. Final repository for long-lived waste, SFL, and encapsulation station for spent fuel, BS	
5. Final repository for reactor waste, SFR	
6. Decommissioning of the nuclear power plants	

## SUMMARY

The Swedish nuclear power utilities are responsible for adopting such measures as are necessary in order to ensure the safe management and disposal of spent nuclear fuel and radioactive waste from the Swedish nuclear power reactors. In order to fulfil this responsibility, the nuclear power utilities have commissioned SKB, the Swedish Nuclear Fuel and Waste Management Co, to plan, build, and operate the necessary facilities and systems.

This report presents a calculation of the costs for implementing all of these measures. The cost calculations are based on a scenario for management and disposal of the radioactive waste products, which has been prepared by SKB and is described in this report.

Since disposal of the high-level (long-lived) waste will not commence until some time into the 21st century, continued RD&D activities may reveal new methods, that can affect both system design and costs. This is expected to lead to overall simplifications in the design.

The facilities and systems that exist are:

- Transportation system for radioactive waste products.
- Central interim storage facility for spent nuclear fuel, CLAB.
- Final repository for radioactive reactor waste, SFR 1.

Future facilities under planning are:

- Encapsulation station for spent nuclear fuel.
- Final repository for long-lived waste.
- Final repository for decommissioning waste.

The cost calculations also include costs for research and development and for decommissioning and dismantling the reactor plants etc.

The total future costs of the Swedish waste management system, starting in 1991, have been calculated to be SEK 45.5 billion in January 1990 prices. These costs will be incurred over a period of about 60 years. SEK 8.0 billion has been spent up to the end of 1990.

This cost calculation is presented annually to SKN, the National Board for Spent Nuclear Fuel, which uses it as a basis to propose a fee on the nuclear electricity production in order to cover all future expenses. The fee for 1990 is on average 1.9 öre/kWh (0.019 SEK/kWh).

## ABBREVIATIONS

BS	Encapsulation station for spent nuclear fuel and core components
BWR	Boiling water reactor (ABB-ATOM)
CLAB	Central interim storage facility for spent nuclear fuel
RD&D	Research, development and demonstration
GA	Common facilities
GD	Common parts of a facility
NPP	Nuclear power station
PWR	Pressurized water reactor (Westinghouse)
SFL	Final repository for long-lived waste
SFL 2	- for spent nuclear fuel
SFL 3	- for long-lived waste from Studsvik and certain operating waste from CLAB (as from 2012) and the treatment station
SFL 4	- for decommissioning waste from interim storage facility and treatment station
SFL 5	- for core components etc
SFR 1	Final repository for low- and intermediate-level waste from reactor operation
SFR 3	Final repository for decommissioning waste from the nuclear power plants
SKI	Swedish Nuclear Power Inspectorate
SKB	Swedish Nuclear Fuel and Waste Management Co
SKN	National Board for Spent Nuclear Fuel
SSI	National Institute of Radiation Protection

## 1. PREMISES

### 1.1 GENERAL

SKB prepares every year, on behalf of the nuclear power utilities, a calculation of the costs for all the measures that are required in order to manage the spent nuclear fuel from the reactors and the radioactive waste deriving from it and to decommission and dismantle the reactor plants. The calculations are based on a scenario for energy production, waste quantities and required measures that is presented in this report. The cost calculation is submitted to the National Board for Spent Nuclear Fuel and is used as a basis for calculating the fee for management of the radioactive waste products of nuclear power that is levied on nuclear-generated electricity.

The premises for the cost calculations have been chosen in such a manner that the future costs are not underestimated. Thus, the waste management system presented here is based on the KBS-3 method (ref. 1), which has been reviewed in connection with the fuelling applications for Forsmark 3 and Oskarshamn 3 and has been found to meet high standards of safety and radiation protection.

Through continued research and development within the waste management field, it is probable that it will be possible to introduce simplifications in the disposal system. Other technological progress will also contribute to such simplifications. These factors are not taken into account in the cost calculations.

Facilities for which sites have not yet been decided have, for the purpose of cost calculation, been assumed to be located inland. The transportation of the waste is assumed to be made by ship to the nearest harbour and thereafter by rail.

In order to obtain a basis for the design of storage and the transport system, certain assumptions have to be made regarding the conditions of operation for the nuclear power plants. The amount of spent fuel and radioactive waste to be handled is dependent on operation time and power output as well as on the factor of energy utilization for each reactor. An early shutdown of reactors will reduce the amount of waste and the overall electrical power output. The Swedish

parliament has proposed a bill regarding an early shutdown of two reactors in the years 1995/96. In order to cover the largest scope of the system, within the present resolution of parliament, this report is based on the amount of spent fuel and radioactive waste given by the operation of all reactors up to and including the year 2010.

The Financing Act only deals with costs that are attributable to management and disposal of spent nuclear fuel and waste deriving from it and to decommissioning and dismantling of the reactor plants. SKB's plan for management of the radioactive waste has also taken into account operating waste from nuclear power plants and waste from non-electricity-generating facilities, mainly in Studsvik, which is estimated to constitute only a few percent of the total waste volume.

## 1.2 ENERGY PRODUCTION AND WASTE QUANTITIES

Electricity generation and fuel consumption are summarized in Table 1.1, in which consideration is taken to the recent permission to raise the effective power output of Ringhals 2 in 1989, as well as to such permissions given earlier for most of the other reactors.

Table 1.1 Electricity production and fuel consumption for the Swedish nuclear power plants.

Reactor and date of com. operation	Thermal capacity MW	Net electrical capacity MW	Energy production TWh			Uranium consumption, tU		
			through 1989	per year from 1990	Total	Discharged through 1989	Total	
B1	75-07-01	1800	600	55.486	4.10	142	230	604
B2	77-07-01	1800	600	51.382	4.10	138	198	574
R1	76-01-01	2500	790	60.270	5.40	174	200	707
R2	75-05-01	2570	850	60.653	5.44	175	203	636
R3	81-09-09	2780	920	43.194	5.89	167	124	587
R4	83-11-21	2780	920	38.198	5.89	162	118	576
O1	72-02-06	1375	440	48.401	3.01	112	203	509
O2	74-12-15	1800	600	58.865	4.10	145	223	603
O3	85-08-15	3300	1160	34.384	7.93	201	81	753
F1	80-12-10	2930	970	58.548	6.63	198	193	786
F2	81-07-07	2930	970	53.188	6.63	192	163	761
F3	85-08-22	3300	1150	34.080	7.86	199	82	747
BWR		21735	7280	454.604	49.78	1500	1572	6044
PWR		8130	2690	142.045	17.21	504	445	1799
All		29865	9970	596.649	66.99	2004	2018	7843

Energy utilization factor for BWR = 0.78

Energy utilization factor for PWR = 0.73

Burnup for BWR: 1990 33 MWd/kgU After 1990 38 MWd/kgU

Burnup for PWR: 1990 38 MWd/kgU After 1990 41 MWd/kgU



Energy production in the Swedish nuclear power plants totalled 63 TWh in 1989, which corresponds to an average energy utilization factor of 73%. The abundance of hydro electric power this year resulted in a decrease in the utilization of the nuclear power plants during 1989. The average energy utilization factor in 1988 was 78% and in 1987 76%. In the calculation of estimated future electric power generation, the energy utilization factors of 78% and 73% are used for BWR and PWR respectively. The real factors of energy utilization are expected to be higher. The factors above are assumed to give ample room for possible disturbing events in the future. The same factors are also used in the planning of future expansion of power production (ref. 2).

The electricity production in the nuclear power plants has been estimated to reach a total of 2 000 TWh by 2010. The corresponding fuel consumption is approximately 7 840 tonnes uranium, of which 6 040 from BWR and 1 800 from PWR.

Most of the spent fuel will be stored in CLAB for about 40 years and then encapsulated and emplaced in a final repository. Only 140 tonnes of uranium are planned to be reprocessed at BNFL, from which no waste will be returned. No reprocessing of Swedish fuel is planned to take place at Cogema. During the late 80s, SKB has transferred the Cogema reprocessing contract to one Japanese and eight West-German firms. For the purpose of covering some transition costs, a sum of MSEK 500 has been included in the cost summary.

Table 1.2 Main types of radioactive waste products to be disposed of.

Product	Principle origin	Unit	No. of units	Volume in final repository m <sup>3</sup>
Spent fuel		canisters	5 700	12 800
Alfa-contaminated waste	Low- and intermediate-level from Studsvik	drums	4 500	1 500
Core components	Reactor internals	moulds	2 400	19 700
Low- and intermediate level waste	Operating waste from nuclear power plants and treatment plants	drums and moulds	57 000	95 000
Decommissioning waste	From decommissioning of nuclear power plants and treatment plants	10-20m <sup>3</sup> containers	5 600	114 000
Total quantity			75 000	243 000

In addition to the amount of fuel accounted for in Table 1.1, there will be 24 tonnes of West-German Mox-fuel and approximately 20 tonnes of fuel from the Ågesta and R1 reactors to be handled. The West-German fuel has been exchanged for 57 tonnes of Swedish spent fuel, shipped to Cogema at an earlier stage.

In addition to spent fuel, the Swedish nuclear power program gives rise to low- and intermediate-level operating waste from the nuclear power reactors, CLAB and the encapsulation station, as well as decommissioning waste when the plants are dismantled. Estimated waste quantities are summarized in Table 1.2. They are described in detail in Appendix 1. The activity content of the different waste types varies widely. The handling and disposal requirement will therefore be dependent on waste type.

### 1.3 PRINCIPLES OF THE WASTE MANAGEMENT SYSTEM

As a basis for the timetable for the Swedish waste management system and for the design of the facilities, it has been assumed in this report that:

- Short-lived waste will be disposed of immediately after it is obtained.
- Spent fuel will be stored for about 40 years before it is placed in a final repository. Heat generation in the final repository is thereby limited.
- Other long-lived waste will be disposed of in connection with the final disposal of spent fuel.

These premises also constitute the planning basis for the research and development activities. The premises may be modified in the future, both in view of the results of the continued RD&D work and as a consequence of future political decisions. Studies have shown that the system contains considerable flexibility (ref. 3).

In their review of SKB's RD&D-programme of 1989 (ref. 7), the National Board for Spent Nuclear Fuel, SKN, made the suggestion that SKB should make a study regarding a step-by-step implementation of the final disposal programme. This could be achieved by commencing with a demonstration facility for 5-10% of the total amount of spent fuel. The fullscale facility could in that way be postponed. The cost consequences of such a strategy have not yet been studied.

## 2. FACILITIES AND SYSTEMS

### 2.1 GENERAL

In order to handle and dispose of the radioactive waste products in Sweden, a number of facilities have to be planned, built and operated. A scenario has been established as a basis for the cost calculations. This chapter presents in outline form the facilities, systems and other activities included in this scenario. Their function and design are briefly described. A more detailed description is provided in the appendix portion of this report.

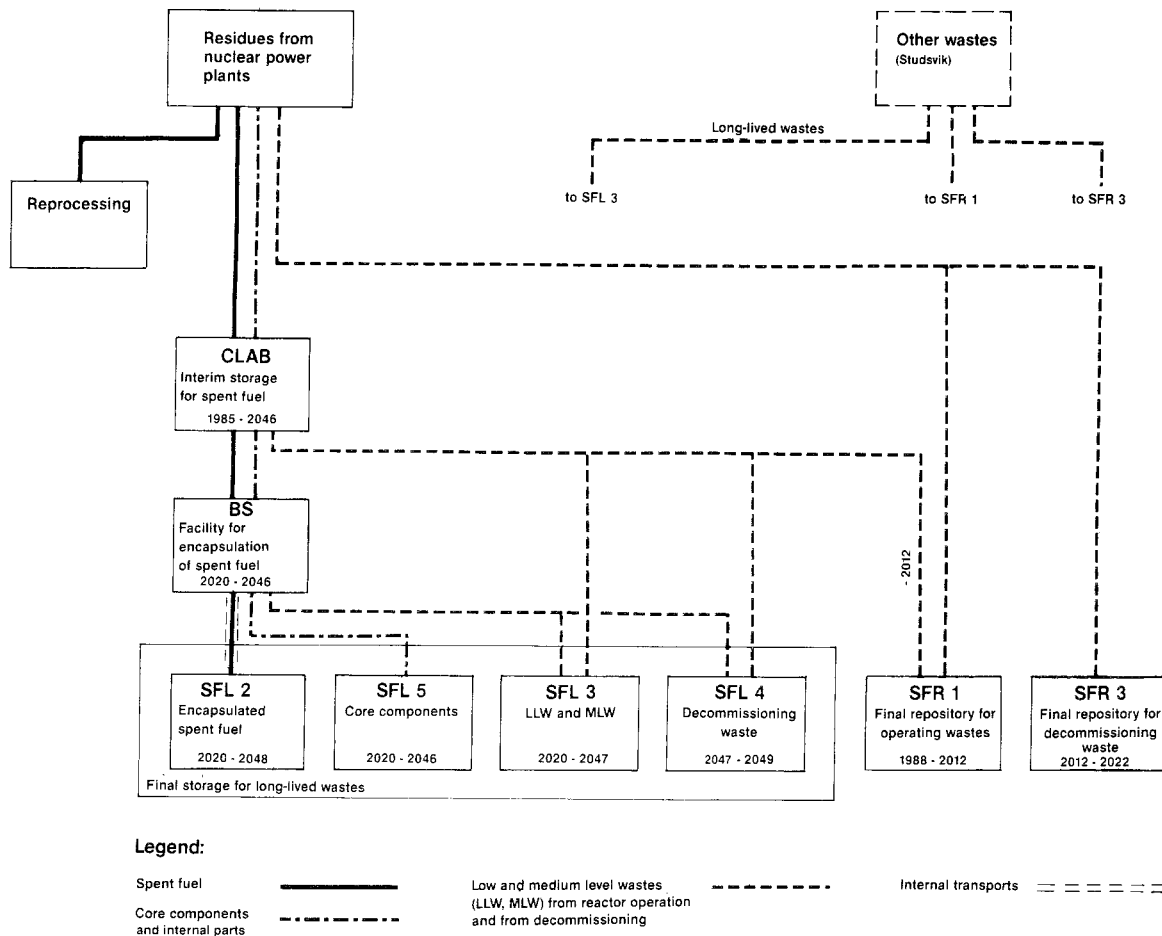

**Figure 2.1** Schematic handling chain for the radioactive waste products of nuclear power.

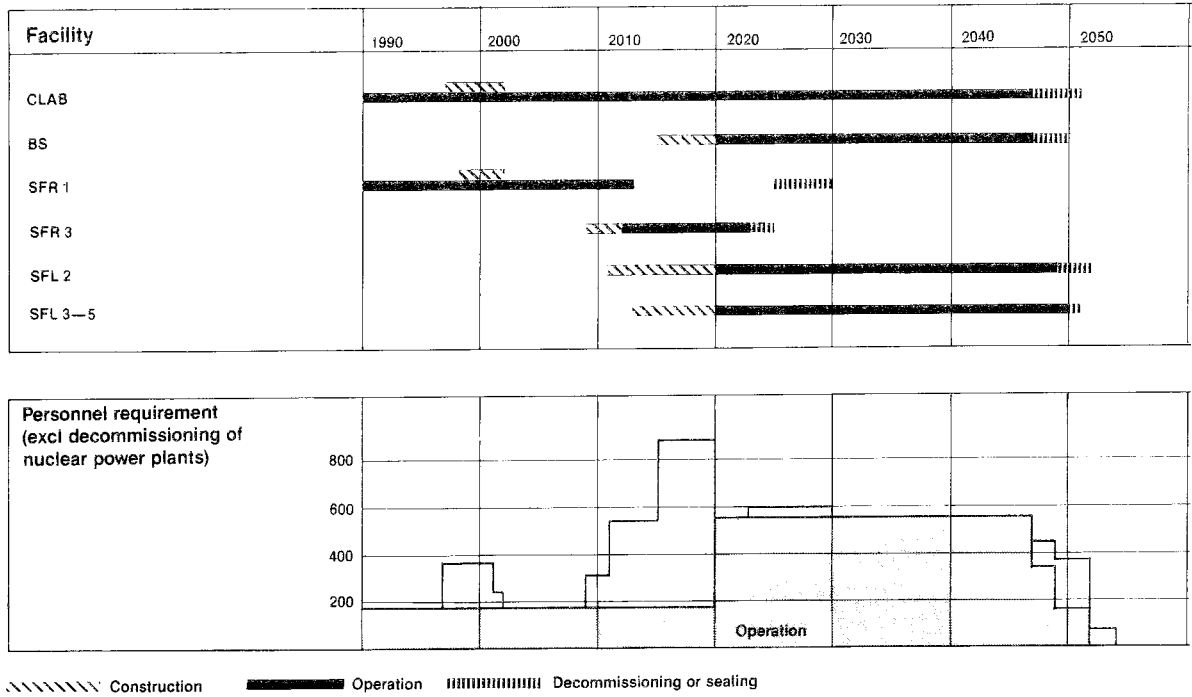

**Figure 2.2** Facilities for management of the waste products of nuclear power. Timetable and personnel requirements.

Since the high-level (long-lived) waste will not be finally disposed of until some decades into the next century, new methods may lead to changes in design as well as in costs for construction and operation.

Figure 2.1 shows what facilities are included and how the waste is planned to be managed. Some of the facilities are in operation, which provides a good basis for the cost calculations. In the case of other facilities, the final design has not yet been chosen. However, as a basis for the cost calculations, a possible waste handling scheme has been described in detail and layout drawings have been prepared. Two facilities, SFL 1 and SFR 2, which were previously included in the system, have been excluded. The timetable for the construction and operation of the facilities is presented in Figure 2.2.

## 2.2 RESEARCH, DEVELOPMENT, AND DEMONSTRATION

The purpose of SKB's research, development, and demonstration activities (RD&D) is to gather the necessary information and data to realize a safe final disposal of spent fuel and other long-lived radioactive waste. An updated research and development programme is presented by SKB every third year. The latest programme was presented in 1989 (ref. 6) and a review report by SKN was presented in March 1990 (ref. 7). At present, SKB is analysing the points of views given by SKN in their report. PLAN 90 is therefore based on data and assumptions presented in SKB's RD&D-programme 89.

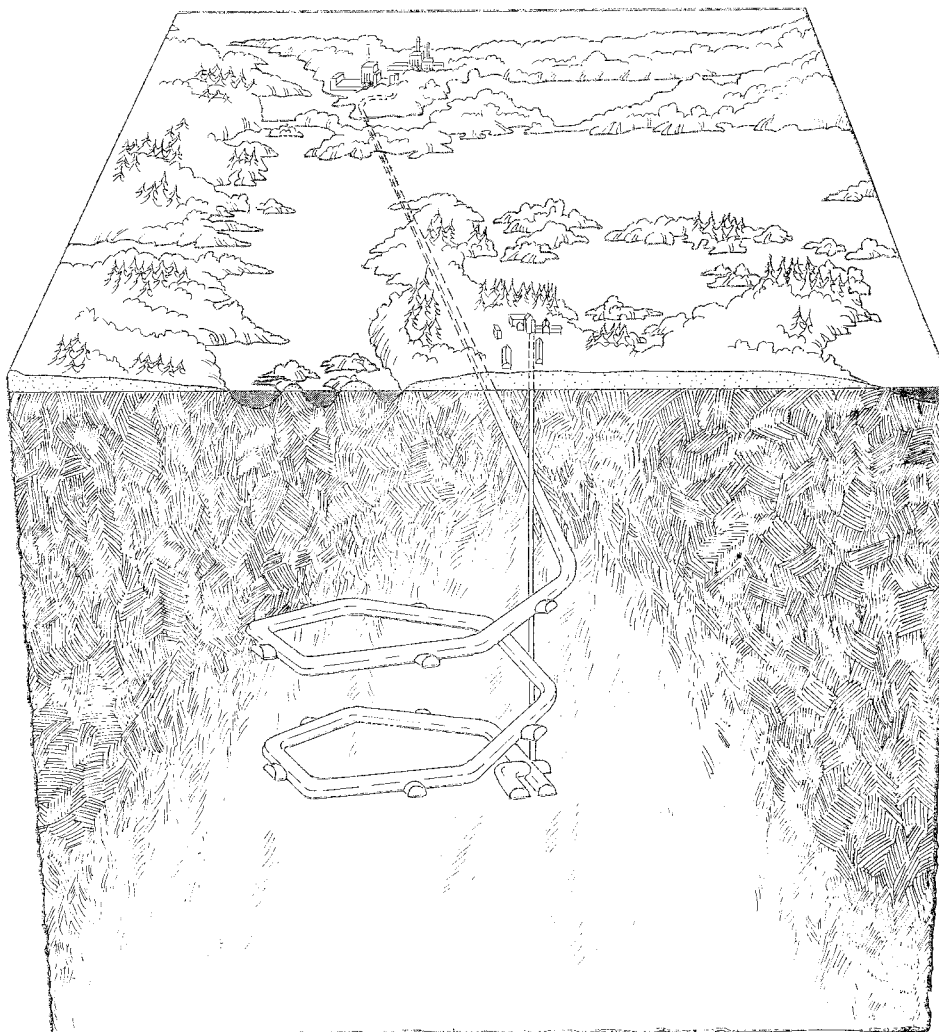

Figure 2.3 Explanatory sketch of the planned Äspö Laboratory.

The aim of the RD&D work during the 1990s will be to establish an adequate basis for a specific Siting Application to be submitted not later than 2003. By that time the system should be optimized and it should be possible to describe it in relation to a specific site. To the Siting Application there should be attached, among others, a detailed analysis concerning the long-time safety of the repository. The analysis has to be based on thorough investigations of the proposed site.

During the 1990s, the RD&D work will be shifted from research and development towards development and demonstration. The selection of a principal system design is planned to take place in the mid 1990s. Candidates for the location of the final repository will be selected and detailed investigations of two of the candidates will start

in good time so that a completion of the Siting Application can be possible in 2003.

One important step in the RD&D work is the establishment of an underground hard rock laboratory - the Äspö Laboratory - in the Community of Oskarshamn. In April 1990, the Government gave permission for the laboratory to be built, under the Act of Management of Natural Resources. The construction work is planned to start at the end of 1990 and the level 500 m below the surface will be reached at the beginning of 1994. The Äspö Laboratory is essential for the testing, verification and demonstration of investigation methods to be used for the detailed investigations of the candidate sites for the final repository. An explanatory sketch of the laboratory is shown in Figure 2.3.

This report covers all calculated RD&D costs up to the year 2010. Costs after 2010, at which time the construction work for the final repository starts, are not separately accounted for. The RD&D costs from that time on are included in the purchaser's planning and design costs, which is part of the investment costs per facility.

### 2.3 TRANSPORTATION SYSTEM

The transportation system is based mainly on sea transport and its principal components are a ship, M/S Sigyn, transport containers and transport equipment at the nuclear power plants and other facilities. The system is designed for accommodating all types of radioactive waste. Reference is made to Appendix 2.

M/S Sigyn has a payload capacity of 1 400 tonnes and is designed as a roll-on/roll-off ship. Loading/unloading by crane is possible as well.

Since 1985, 1 100 tonnes of fuel have been shipped from the nuclear power plants to CLAB and during the same time 4 000 m<sup>3</sup> low and intermediate level waste to SFR.

Containers designed to meet high demands as regards radiation shielding and to withstand large external stresses are used for the transport.

Spent nuclear fuel, core components, and core internals are transported in cylindrical casks. One cask can take between 3 and 6 tonnes of fuel.

For the transport of intermediate level waste to SFR, radiation shielding steel containers, called ATB, are used. A common type holds about 20 m<sup>3</sup> of waste and the weight full is 120 tonnes. For low level waste standard shipping containers will be used.

In January 1990, SKB's system included 10 fuel casks, 2 casks for core components and 27 ATB.

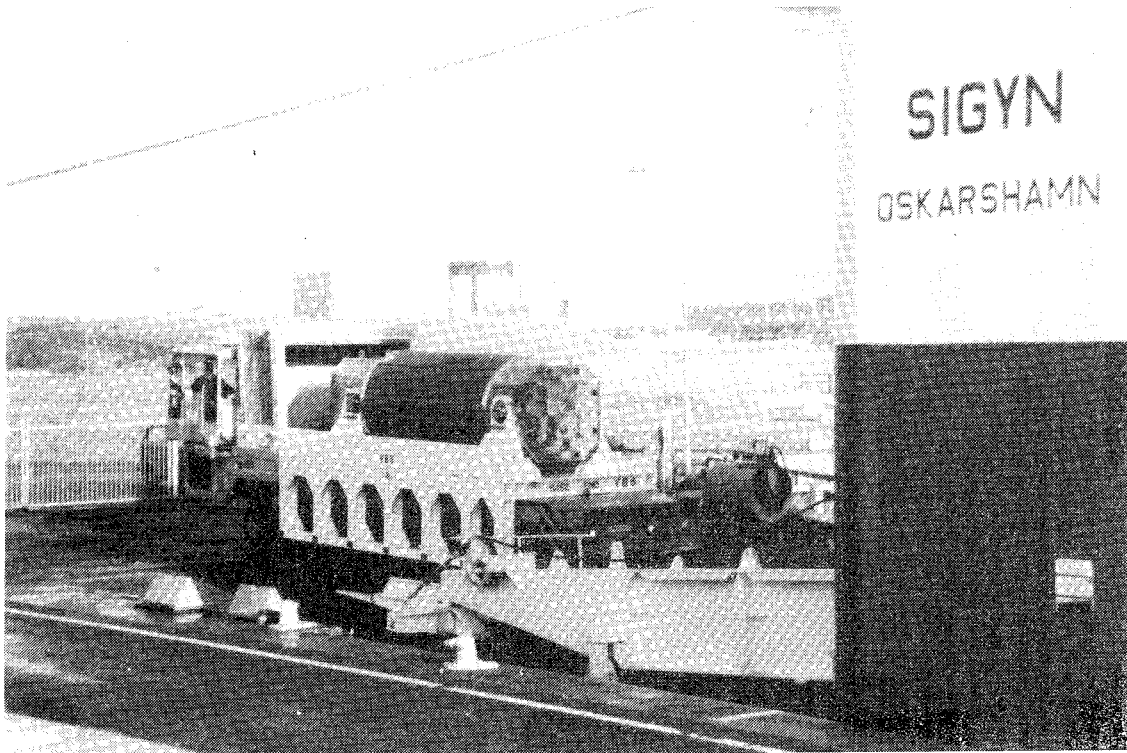

Figure 2.4 Loading of a fuel transport container onto the M/S Sigyn.

During loading and unloading, the containers are transported short distances between the vessel and the storage facilities by special terminal vehicles, see Figure 2.4. At present five vehicles are used.

Since the site of the final repository for long-lived waste, SFL, has not yet been determined, it has conservatively been assumed in the cost calculations that about 750 km of sea transportation will be needed from CLAB to a harbour, and a further 200 km of railway transportation to SFL.

## 2.4

### CENTRAL INTERIM STORAGE FACILITY FOR SPENT NUCLEAR FUEL, CLAB

The central interim storage facility for spent nuclear fuel, CLAB, is situated adjacent to the Oskarshamn power station. The storage facility was taken into operation during 1985 and was originally designed to store about 3,000 tonnes of fuel (uranium weight) in four pools. By the introduction of new storing cassettes the capacity of these pools will gradually increase to about 5,000 tonnes.



The management of transport casks in the receiving section

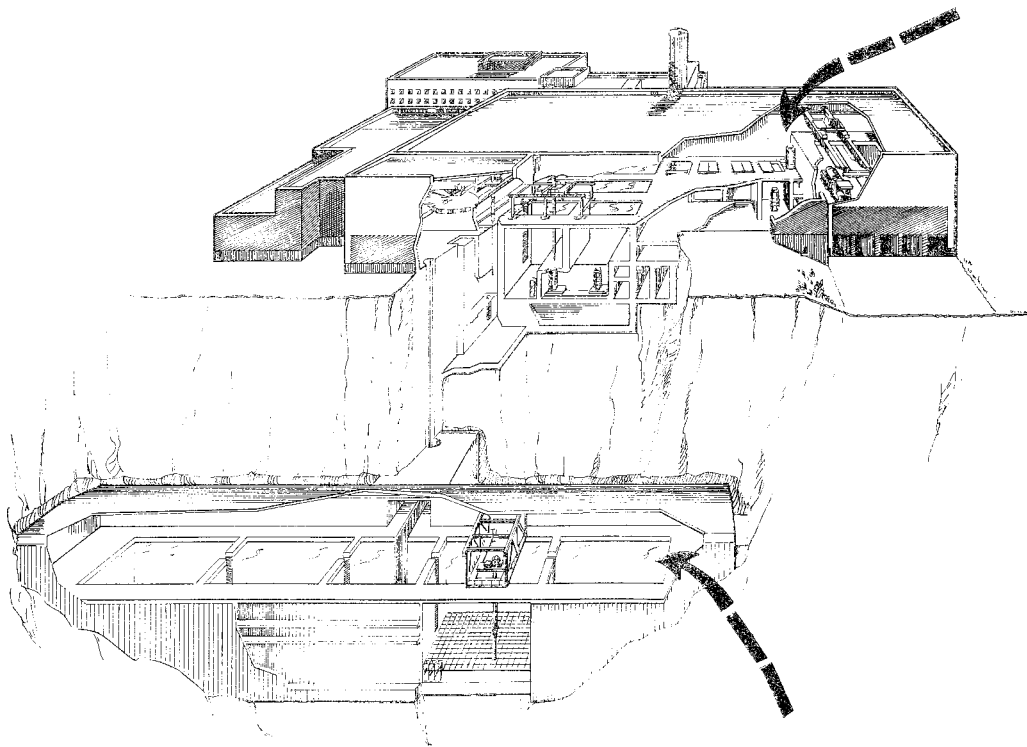

The management of storage canisters in the storage section

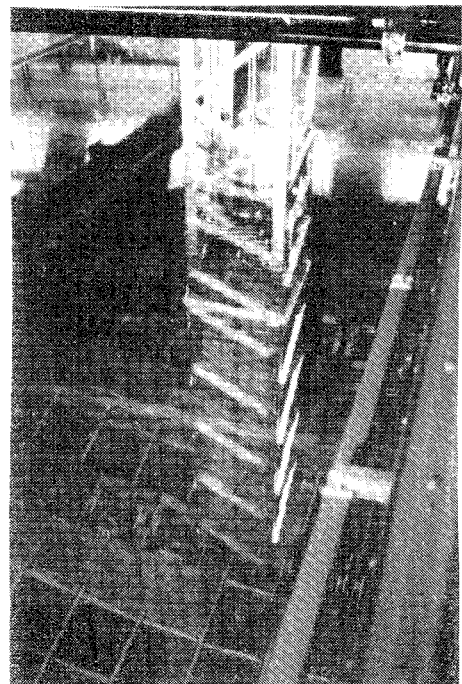

Figure 2.5 CLAB stage 1.



At the beginning of 1990, fuel corresponding to 1,100 tonnes of uranium was stored in the facility.

In the late 1990s, the capacity of the facility will be expanded so that all fuel from the Swedish nuclear power program can be stored in CLAB. Core components and reactor internals will also be stored in the facility prior to final disposal in the SFL.

CLAB consists of an above-ground complex for receiving the fuel and an underground section with the storage pools. The above-ground complex also contains equipment for ventilation, cooling and purification of water, waste handling, electrical systems etc as well as premises for administration and operating staff. Reception of fuel and all handling is made under water.

The storage pools are located in a rock cavern with roof about 30 m below the surface. The rock cavern in the first store is 120 m long, 21 m wide and 27 m high. The storage pools are made of concrete with stainless steel lining. The fuel is today stored in canisters with either 16 BWR-elements or 5 PWR-elements. The new canisters which will be used from 1991 can take 25 BWR-elements or 9 PWR-elements. One pool contains 300 cassettes.

The storage capacity is planned to be expanded by the construction of a new rock cavern parallel to the existing one. The new rock cavern will hold 4 pools for spent fuel and one for core components and reactor internals. These are stored in similar canisters to those for the spent fuel.

When a fuel transport arrives at CLAB, the transport vehicle with the cask is driven into the air lock underneath the reception hall floor. The cask is inspected, and after removal of the shock absorbers it is coupled to one of the main overhead cranes by means of a lifting frame. The cask is raised upright and lifted through the hatch in the roof of the air lock for transfer to one of the cooling cells.

The cask is provided with a protective skirt in order to protect the cooling fins against mechanical damage and contamination during the subsequent reception work. The annular space between the cask and the skirt is filled with water, which is circulated via hoses connected to a separate skirt cooling circuit in the cooling system.

## 2.5 ENCAPSULATION STATION FOR SPENT FUEL

The spent fuel is encapsulated prior to disposal in copper canisters in accordance with the method described in KBS-3 (ref. 1). The empty spaces in the canisters are filled with lead in order to enable the canister to resist the high water pressures prevailing at the repository level.

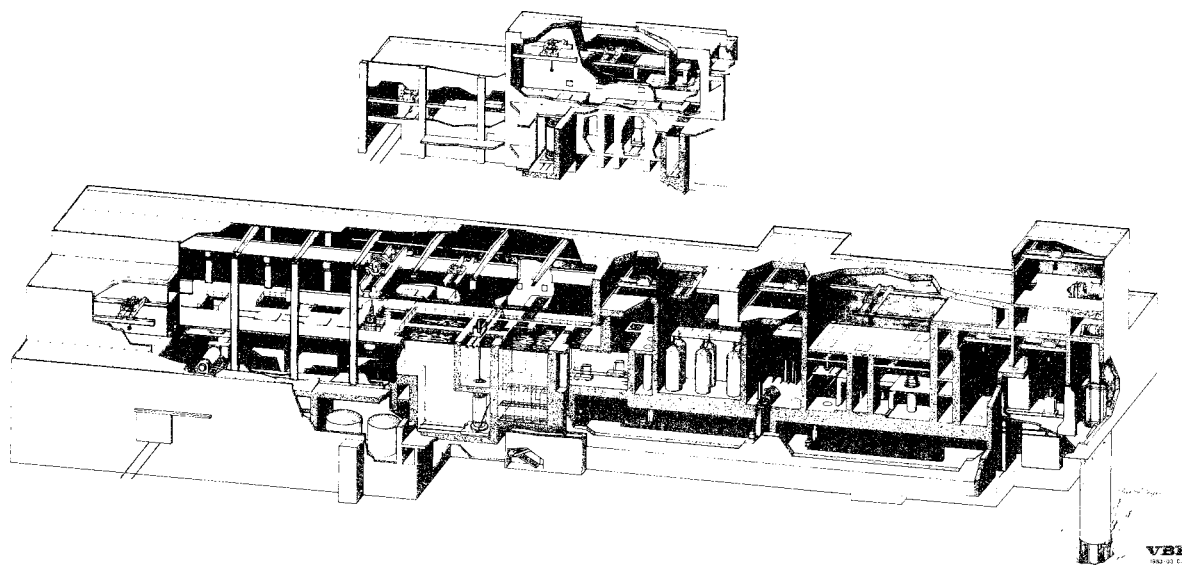

Figure 2.6 Encapsulation station for spent fuel.

In the scenario chosen, the encapsulation station has been located directly above the final repository for the spent fuel. It is situated above ground.

The facility consists of the following main sections:

- Arrival and receiving section.
- Encapsulation and dispatch section for fuel, with elevator down to the repository area.
- Encapsulation section for core components etc.
- Service section containing stores, lead melting equipment etc.
- Auxiliary systems with cooling and purification systems as well as electricity and control equipment.
- A side building that houses personnel and office quarters.

Transport casks containing fuel or core components etc. arrive at the encapsulation station by rail. The fuel is unloaded under water in the same manner as in CLAB. The further handling of the fuel is made dry in a hot cell. Before the fuel is placed in a copper canister the fuel boxes are separated from the fuel.

The lead-filling of the canisters is made in a special oven. The canisters are then moved to positions for cooling, lid welding and checking and further to a buffer storage before transport down in the repository.

The encapsulation line is duplicated to permit continuous operation even in the case of disturbances in the operation.

The facility is designed for an average annual capacity of 210 fuel canisters (one canister per day for 10 months). The facility is mainly operated in the daytime. In total, approximately 5 700 canisters will be processed in the encapsulation station during the period 2020 - 2046. The facility will thereafter be dismantled.

## 2.6 FINAL REPOSITORY FOR LONG-LIVED WASTE

### **Common facilities**

The final repository for long-lived waste, SFL, and the encapsulation station for spent fuel, BS, are assumed in this report to be situated in the inland. The transports are assumed to be made by ship to an existing harbour and from there by rail to the final repository.

Service facilities such as housing, workshops, water supply and sewerage, electricity supply, concrete station, canteens, guard room etc. will be built at the SFL. A plant for compacting the bentonite and a plant for crushing rock material will also be provided on the site.

The common facilities also include the central administration building for the site organization.

There are four different final repository areas at the SFL:

- SFL 2 for spent fuel
- SFL 3 for low- and intermediate-level operating waste from CLAB (after 2012) and long-lived waste from Studsvik
- SFL 4 for decommissioning waste from the interim storage facility and encapsulation station
- SFL 5 for core components and reactor internals

A previously planned unit, SFL 1, for vitrified waste from reprocessing has been omitted.

### **SFL 2**

SFL 2, the final repository for spent fuel, is situated directly below the encapsulation plant at a depth of about 500 m. It consists of a series of parallel deposition tunnels with a total length of appr. 40 km. The deposition tunnels are connected by transport tunnels. The deposition tunnels have cross sections of 14 m<sup>2</sup> and lie 40 m apart.

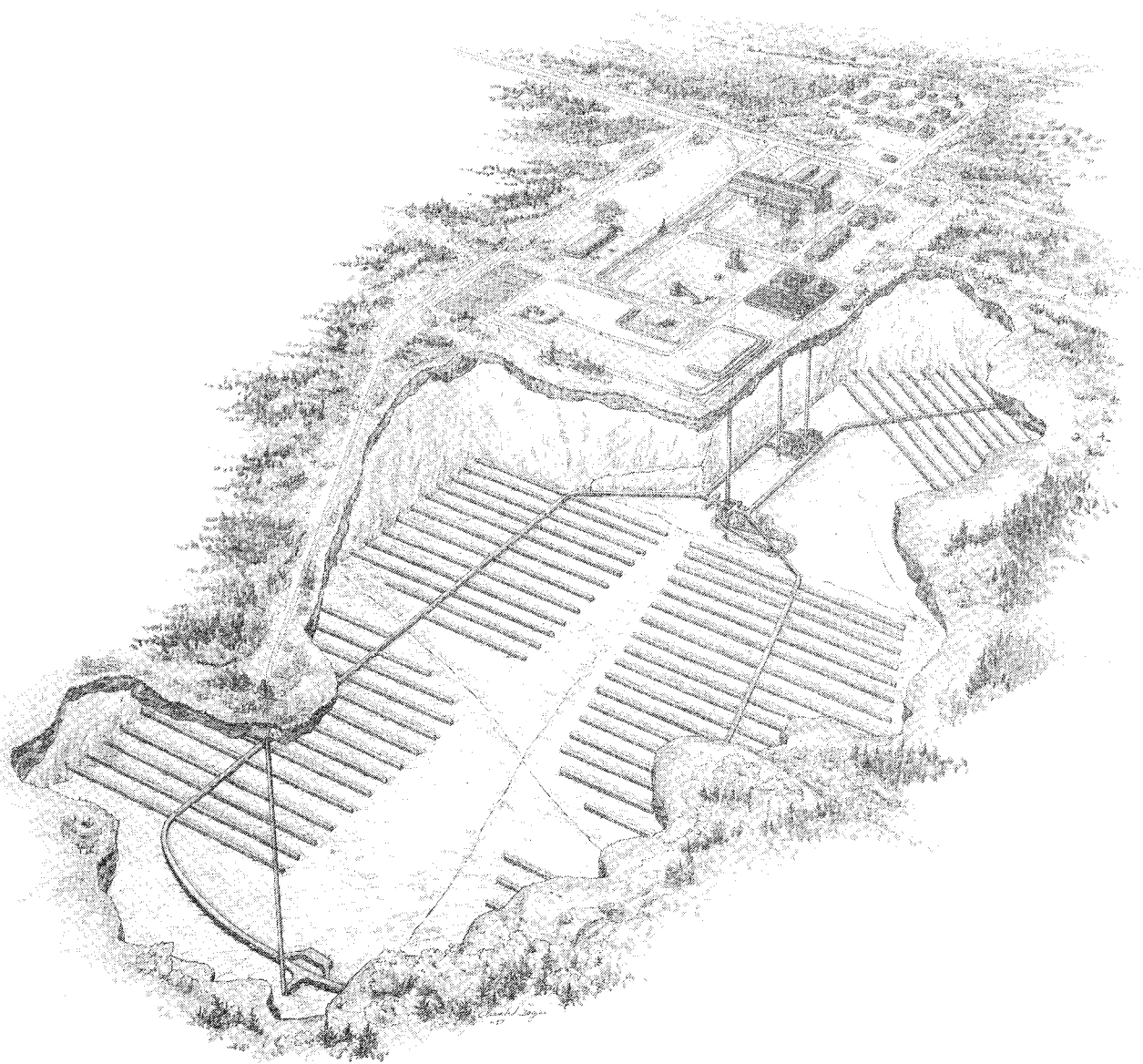

Figure 2.7 SFL 2

The copper canisters are placed in vertical holes, drilled in the bottom of the deposition tunnels, and surrounded by a layer of compacted bentonite. The distance between the holes and tunnels have been chosen to keep the temperature in the bentonite below 80° C. The total number of deposition holes is 5 700. Costs for an extra 10% tunnelling are included considering that deposition is not suitable in certain areas.

The copper canister is transported down in a radiation-shielding elevator cage from the encapsulation station to the deposition level, where it is picked up by the deposition vehicle and driven out to the deposition location. At the deposition location the canister is put vertically into the deposition hole. Afterwards blocks of highly compacted bentonite are placed around the canister.

The deposition tunnels are backfilled with a mixture consisting of 15% bentonite and 85% quartz sand.

The emplacement of copper canisters will proceed during the period 2020-2048. The repository will thereafter be sealed and all service tunnels, vaults, and shafts will be backfilled.

### **SFL 3-5**

All low- and intermediate-level operating waste that is to be disposed of after 2012, when SFR 1 has been closed, is placed in SFL 3, 4 or 5, depending on the type of waste in question. No consideration has to be taken to the effects of the temperature since the heat emission is negligible. The storage chambers, which are located at a depth of about 500 m, are reached through a common shaft. The shaft is situated a few kilometres from SFL 2.

SFL 3 consists of a long rock cavern. The long-lived waste from Studsvik and the operating waste from CLAB (after 2010) and the encapsulation station are deposited in SFL 3. The waste is stacked in concrete cells, 2.5 m square, after which the remaining empty space in the cells is filled with concrete. All handling is remote-controlled. The space between the concrete cells and the rock is filled up with a sand-bentonite mixture.

SFL 4 consists of the tunnel system that has to be built for SFL 3 and SFL 5. Low-level decommissioning waste from CLAB and the BS, transport casks etc, that are to be finally deposited at a late stage, will be placed in SFL 4 shortly before the facility is sealed.

SFL 5 consists of two tunnels in which the concrete moulds for core components etc. are placed and grouted in with concrete.

## **2.7**

### **FINAL REPOSITORY FOR REACTOR WASTE, SFR**

A final repository for operating waste from the nuclear power stations is in operation since 1988 at Forsmark nuclear power station. The facility is situated underneath the Baltic Sea with a rock cover of about 60 m. From the harbour at Forsmark, two 1 km long tunnels lead out to the repository area. A final repository for decommissioning waste from the nuclear power plants, SFR 3, is planned in connection with SFR 1. SFR 2, which is intended for core com-

ponents etc., is assumed in this report not to be built, being instead replaced by SFL 5.

Radioactive waste from CLAB and similar radioactive waste from non-electricity-producing activities, including Studsvik, will also be disposed of in SFR.

### **SFR 1**

SFR 1 will, when completed, consist of five to six 160 m long rock vaults and two 70 m high cylindrical rock caverns containing concrete silos, see Figure 2.8. The waste containing most of the radioactive substances will be placed in the silos. The first construction stage, which was completed in 1987, comprises four rock vaults and one silo. The second construction stage will be carried out at the end of the 1990s. In all, SFR 1 will hold 90,000 m<sup>3</sup> of waste, of which about 37,000 m<sup>3</sup> in silos.

The concrete silo stands on a bed of sand and bentonite. The silo is divided into vertical shafts, where the waste is deposited and surrounded with concrete grout. The space between the silo and the rock is filled with bentonite.

The handling of the intermediate level waste is remotely controlled, while the low active waste is handled by a fork-lift truck.

A crew of about 20 persons operates the facility. To this number should be added some services that are obtained from the nearby power plant.

Up to April 1990, 4 000 m<sup>3</sup> waste have been deposited in SFR. The facility is expected to be sealed in the early 2010s.

### **SFR 3**

The decommissioning waste from the nuclear power stations and Studsvik will be deposited in SFR 3. SFR 3 is planned to consist of five rock vaults of a type similar to those in SFR 1. Most of the decommissioning waste can be transported in standard containers which are emplaced in the rock vaults without being emptied. A total of 104,000 m<sup>3</sup> of decommissioning waste will be disposed of in SFR 3.

SFR 3 will be in operation during the period when the nuclear power plants are dismantled.

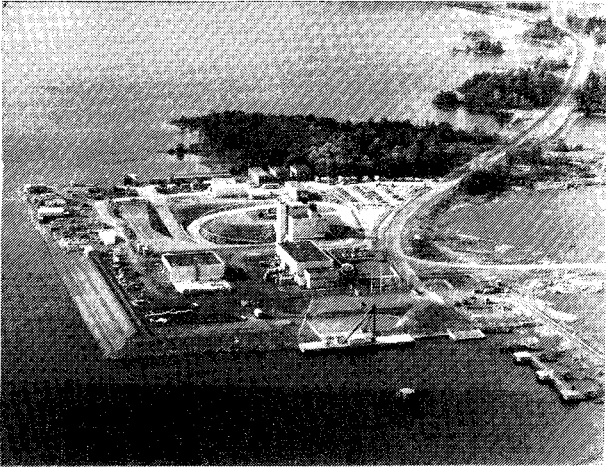

View of the above ground section

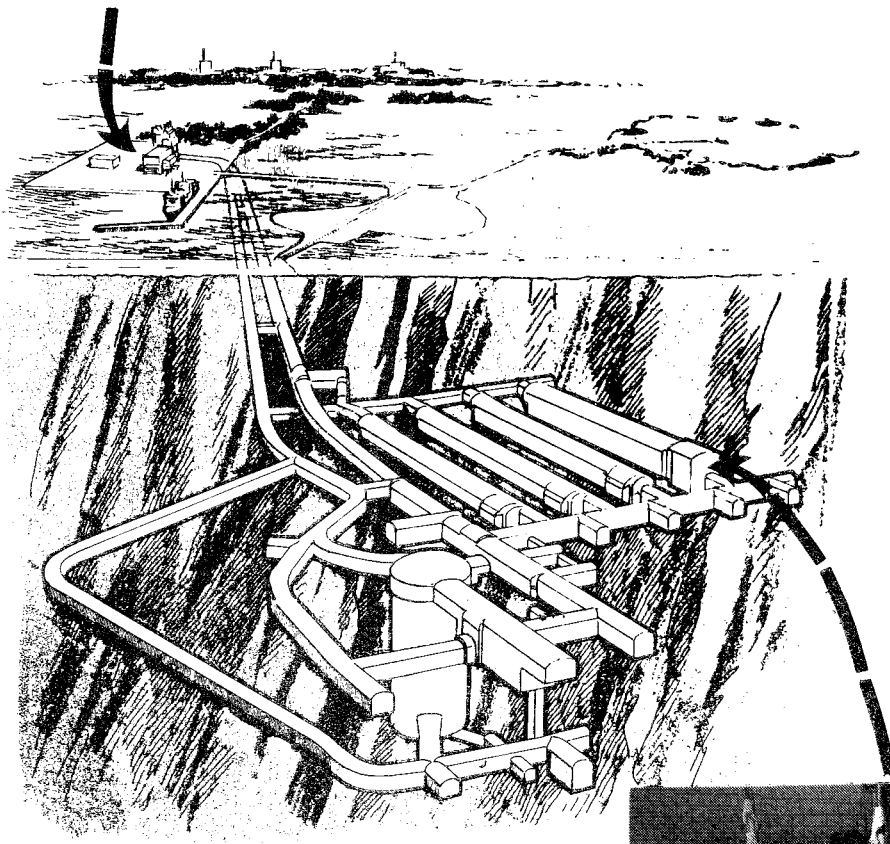

Emptying of a transport container

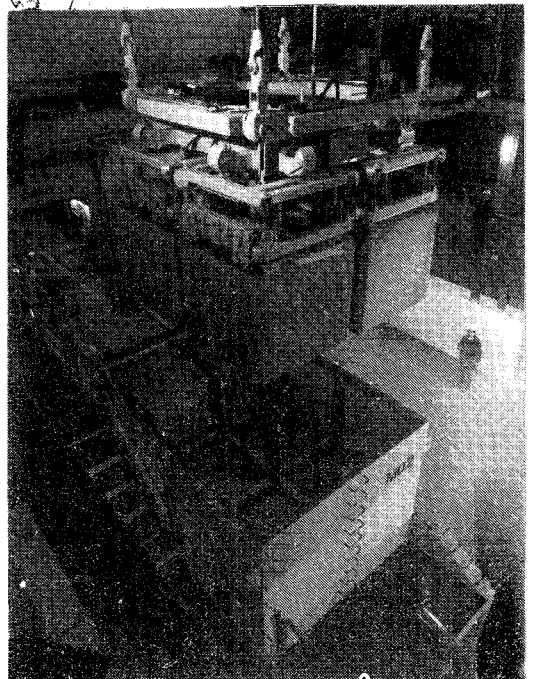

Figure 2.8 SFR 1, stage 1

## 2.8 DECOMMISSIONING OF NUCLEAR POWER PLANTS

The measures required for management of the radioactive waste products of nuclear power also include decommissioning the facilities after they have been taken out of operation (ref. 5).

The timetable for decommissioning of the nuclear power plants is influenced by a number of different factors. Dismantling can be carried out in a safe manner a short time after shutdown, but there are advantages with deferred dismantling. Here it is assumed that the plants are dismantled early.

With regard to resource utilization and the reception capacity in CLAB and in SFR, it is suitable to stagger the start of dismantling of different units. Here the time between the start of dismantling of units at the same station is assumed to be two years.

During the period from when the unit is taken out of operation until dismantling is begun, removal of fuel, decontamination and preparations for dismantling (shutdown operation) take place. During this period, the personnel force can be gradually reduced. The actual work of dismantling is expected to take five years per unit and to employ an average of a couple of hundred persons.

The radioactive waste from decommissioning is all low- and intermediate-level. However, the activity level varies considerably between different parts. The waste with the highest activity, the reactor internals, is assumed to be stored in CLAB for a period of about 30-40 years before being disposed of in SFL 5. Other radioactive decommissioning waste will be transported directly to SFR 3 and deposited there. A large quantity of the decommissioning waste can be declassified, some of it after decontamination.



### 3. COSTS

#### 3.1 GENERAL

All costs for the management and disposal of the radioactive waste products described in section 1.2 are reported in this chapter. The cost calculations have been based on the scenario and the facilities, systems etc that are described in chapter 2.

In the accounting system, costs incurred up to and including 1990 are distinguished from future costs. The future costs are estimated at January 1990 prices. Previously incurred costs are quoted in current prices.

Cost calculations have been carried out for all facilities and systems. Experience from the construction and operation of CLAB, SFR and the transportation system has thereby been incorporated.

The costs are reported in detail in a computerized cost scheduling system called BECOST, which permits present value calculations and variation analyses as well as distribution of the costs among different nuclear power plants etc.

The costs for different facilities are reported here broken down into the following items: investment, reinvestment, operation, and decommissioning and sealing. Normally, only those costs that arise before a facility or part of a facility is taken into operation are attributed to investment costs. In SFL 2, where the deposition tunnels will be excavated continuously during the deposition phase, the costs for this work have, however, been assigned to the investment costs.

Some costs that do not fall under the Financing Act are also reported (operating waste from the nuclear power plants, spent fuel from Ägesta and waste from Studsvik).

### 3.2 CALCULATION METHOD

The cost calculations are based on functional descriptions for each facility, which result in layout drawings, equipment lists, personnel forecasts etc. For facilities and systems that are in operation, this background material is very detailed, while the degree of detail is lower for future facilities.

The costs of the future facilities are calculated in several steps. For each cost item, a base cost is calculated, after which a contingency allowance for unforeseen costs is added. the base costs include:

- quantity-calculated costs
- non-quantity-calculated costs
- secondary costs

Quantity-calculated costs are costs that can be calculated directly with the aid of the design specifications and with knowledge of unit prices, e.g. for concrete casting, rock blasting and operating personnel. In estimating both quantities and unit price, experience gained in construction of the nuclear power plants, CLAB and the SFR has been drawn on.

All details are not included on the drawings. These non-quantity stipulated costs can be estimated with good accuracy on the basis of experience from other similar work.

The final item included in the base costs is secondary costs. These include costs for administration, engineering, purchasing and inspection as well as costs for temporary buildings, machines, housing, offices and the like. The amounts allowed for these costs are also relatively well known, and have been calculated on the basis of the assumed service requirements during the construction phase.

A contingency allowance is added to the calculated base costs for unforeseen items. The size of the contingency allowance is determined object-by-object on the basis of the risks of additional work and the engineering level of the facility. On an average it is about 28%.

### 3.3 REPORTING OF FUTURE COSTS

The costs reported in this section are given in the price level January 1990. The costs are distributed in time, which permits discounting with different values for the real interest rate.

Table 3.1 shows the future costs for waste management. The costs are distributed by object and category of cost. The total future costs from 1991 amount to MSEK 45,500.

The table also separates costs under the Financing Act, i.e. the total cost less costs for low- and intermediate-level operating waste and waste from Studsvik and Ågesta. The future costs under the Financing Act from 1991 amount to MSEK 44,100.

Table 3.2 shows the future costs broken down by object and distributed over time. Figure 3.1 shows the annual future costs.

**Table 3.1** Future costs (MSEK) from 1991, including contingency allowance for unforeseen items (January 1990 prices).

Object	Cost category	Total future costs	Total future costs per object	Future costs under Financing Act <sup>1)</sup>
SKB, Adm, RD&D	-	3 707	3 707	3 707
Transports	Reinvestment	534		
	Operation	867	1 401 *	1 224
Decommissioning NPP	Shutdown operation	1 204		
	Dismantling	9 186	10 390	10 390
CLAB	Investment	792		
	Reinvestment	786		
	Operation	4 143		
	Decommissioning	306	6 027 *	5 996
SFL-BS GA	Investment	2 959		
	Reinvestment	182		
	Operation	1 461		
	Decommissioning	201	4 803 *	4 736
BS	Investment	2 830		
	Reinvestment	127		
	Operation	5 318		
	Decommissioning	254	8 529 *	8 486
SFL 2	Investment	3 343		
	Reinvestment	42		
	Operation	562		
	Sealing	2 913		
	Decommissioning	44	6 904 *	6 870
SFL 3-5 GD	Investment	571		
	Reinvestment	20		
	Operation	286		
	Decom. + sealing	99	976 *	904
SFL 3	Investment	205		
	Operation	21		
	Decom. + sealing	49	275 *	218
SFL 4	Investment	23		
	Operation	15		
	Decom. + sealing	1	39 *	39
SFL 5	Investment	100		
	Operation	30		
	Decom. + sealing	59	189 *	184
SFR GD	Investment	34		
	Decom. + sealing	3	37 *	1
SFR 1	Investment	263		
	Operation	454		
	Decom. + sealing	78	795 *	24
SFR 3	Investment	362		
	Operation	134		
	Decom. + sealing	46	542 *	522
Reprocessing <sup>2)</sup>	-	840	840	840
Total			45 454	44 141

\* Also includes costs outside the Financing Act. Total over all concerned objects:  
Waste from Studsvik, Ågesta etc MSEK 369  
Other low- and intermediate- level waste MSEK 944

1) Future costs less costs for Studsvik waste etc and other low- and intermediate-level waste

2) Costs of reprocessing including costs at BNFL and for transition of contracts with COGEMA

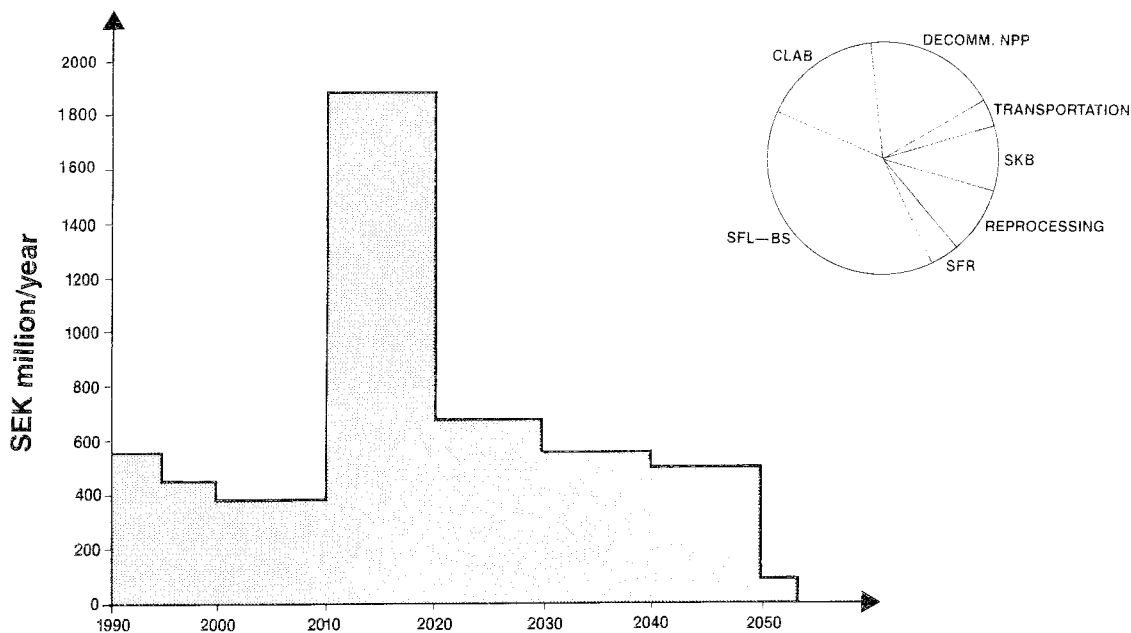

Figure 3.1 Annual future costs and distribution of the total cost among different facilities. (January 1990 prices)

Table 3.2 Future costs (MSEK) per object under the Financing Act distributed over time. (January 1990 prices)

Year	SKB Adm,RD&D	Transp.	Decom. NPP	CLAB	SFL- -BS	SFR 1 + 3	Reproc.	Total costs	Accumulated costs
1991-94	820	45	0	374	0	3	500	1 742	1 742
1995-99	762	58	0	1 040	0	12	170	2 042	3 784
2000-2009	2 125	252	0	1 004	132	27	170	3 710	7 494
2010-2019	0	200	9 471	802	7 678	424	0	18 575	26 069
2020-2029	0	396	919	1 045	4 253	81	0	6 694	32 763
2030-2039	0	143	0	830	4 505	0	0	5 478	38 241
2040-2049	0	130	0	779	4 156	0	0	5 065	43 306
2050-2059	0	0	0	122	713	0	0	835	44 141
Total from 1991	3 707	1 224	10 390	5 996	21 437	547	840	44 141	

3.4 PREVIOUSLY INCURRED COSTS

Table 3.3 reports costs incurred through 1989, in current prices excluding interest, and 1990 budgeted costs.

Table 3.3 Incurred and estimated costs through 1990.  
(MSEK current prices)

Object	Cost category	Costs incurred through 1989	Estimated costs 1990
SKB (RD&D, Info, Adm)	-	792	179
Transports	Investment	254	-
	Operation	206	15
CLAB	Investment	1 750	16
	Operation	477	74
SFR 1	Investment	747	2
	Operation	46	22
Reprocessing	-	3 065	325
Total		7 337	633

### 3.5 MARGINAL COSTS

The costs of the facilities per unit are presented in Table 3.4, both as average cost and as marginal cost. The marginal costs have been calculated on the basis of an estimate of the variable cost portion for each facility section. The capacity of the encapsulation station has been kept constant, so that a change in fuel quantity leads to a change in operating time.

The marginal costs given in the table are relatively roughly estimated and only apply within a limited interval (approx. 20%) of the quantities given in column 3.

Table 3.4 Marginal costs for certain parts of the system.  
(January 1990 prices)

OBJECT	COST MSEK	QUAN- TITY	UNIT (PARAMETER)	kSEK/ UNIT	MARG. COST kSEK/UNIT	REMARKS
<u>TOTAL FACILITIES ETC FOR MANAGEMENT OF FUEL</u>						
Facilities for management of fuel incl. core compo- nents and RD&D	36 500	7 691	ton fuel	4 750	2 230	
<u>DIFFERENT PARTS OF THE SYSTEM</u>						
<u>TRANSPORTS</u>						
						Includes costs for all transports of the waste
Total	2 062	12 600	trpt unit	164		Ship-transported fuel and waste. The trpt. unit is a cask or container
Spent fuel	1 516	7 691	ton fuel	197	54	Cost incl. core components and LI waste from CLAB. 1 725 tonnes of fuel internally transported OKG-CLAB
Operating waste from NPP	186	59 300	m <sup>3</sup> LM waste	3,1	0,3	By ship transport from NPP to SFR 1 of total 72 800m <sup>3</sup>
Decommissioning waste from NPP	317	68 000	m <sup>3</sup> decommission- ing waste	4,7	0,6	By ship transport from NPP to SFR 3 of total 100 000 m <sup>3</sup> . Incl. internals to SFL 5
Studsvik waste	43	15 500	m <sup>3</sup> waste	2,8	0,3	Various wastes
<u>INTERIM STORAGE FACILITY</u>						
CLAB	9 532	7 691	ton fuel	1 239	530	Incl. core components and reactor internals (max. 10% of storage volume)
<u>FINAL DISPOSAL</u>						
SFL-BS total	21 715	7 691	ton fuel	2 823	1 660	
		alt. 5 659	copper canister	3 837	2 260	
BS	10 951	7 691	ton fuel	1 424	770	Incl. part of SFL GA and core comp.
		alt. 5 659	copper canister	1 935	1 045	
SFL 2	8 866	7 691	ton fuel	1 153	805	Incl. part of SFL GA
		alt. 5 659	copper canister	1 567	1 090	Incl. part of SFL GA
SFL 3	1 038	6 500	m <sup>3</sup> LM waste	160	44	Incl. part of SFL GA and SFL 3-5 GD
SFL 5	713	2 380	mould	300	95	Incl. part of SFL GA and SFL 3-5 GD
		alt. 7 691	ton fuel	93	31	Incl. part of SFL GA and SFL 3-5 GD
SFR 1	1 877	90 000	m <sup>3</sup> LM waste	21	11	Incl. SFR GD
SFR 3	542	104 000	m <sup>3</sup> decom. waste	5,2	3,1	

### 3.6 WASTE MANAGEMENT FEE

According to Swedish law, the costs for the back-end of the nuclear fuel cycle and for the decommissioning of the reactors shall be borne by the owners of the reactors. To make sure that funds shall be available a fee is levied on the production of electricity in nuclear power plants. The level of the fee is determined annually by the Government. The decision of the Government is based on a proposal by SKN, which has been calculated using the results of the annual cost calculations presented by SKB in this report and its predecessors.

In making the proposal, SKN has to consider all relevant factors, such as total costs, expected operation time of the reactors and interest on the money collected in funds. Separate fees are proposed for each reactor owner. For 1990 the fee has been 1.9 öre/kWh (SEK 0.019/kWh) on average.

The fees are paid into funds at the National Bank of Sweden. The funds are controlled and administered by SKN.



## REFERENCES

1. Final Storage of Spent Nuclear Fuel - KBS-3  
Parts I-IV  
Svensk Kärnbränsleförsörjning AB  
May 1983
2. Värmekraftens tillgänglighet.  
("Availability of thermal power")  
SDT-rapport  
April 1989.
3. Kärnkraftens slutsteg  
Alternativa tidplaner för hantering av använt kärnbränsle  
- konsekvenser för planering, säkerhet och kostnader  
(Alternative timetables for handling of spent nuclear fuel -  
consequences for planning, safety and costs")  
Svensk Kärnbränslehantering AB  
December 1985
4. SKB Annual Report 1989  
Technical Report 89-40  
Svensk Kärnbränslehantering AB  
May 1990
5. Technology and costs for decommissioning a Swedish nuclear power  
plant, Technical Report 86-16  
Svensk Kärnbränslehantering AB  
May 1986
6. SKB R&D-Programme 89  
Management and final disposal of waste from nuclear power  
production.  
Programme for research, development and other activities  
September 1989.
7. SKN R&D-Programme 89  
Review by the National Board for Spent Nuclear Fuel  
Dnr 93/89, March 1990

## APPENDICES

- 1 Spent fuel and radioactive waste in Sweden assuming operation of all plants through 2010.
- 2 Transportation system.
- 3 Central interim storage facility for spent nuclear fuel, CLAB.
- 4 Final repository for long-lived waste, SFL and encapsulation station for spent fuel, BS.
- 5 Final repository for reactor waste, SFR.
- 6 Decommissioning of the nuclear power plants.

## APPENDIX 1

SPENT FUEL AND RADIOACTIVE WASTE IN SWEDEN ASSUMING  
OPERATION OF ALL PLANTS THROUGH 2010

Waste category	Dimensions of waste units in m $\phi$ = diameter (Dimensions before encapsulation for final disposal)	No. of packages	No. of transport units casks/ con- tainers	Volume in final repository m <sup>3</sup>	Final destination
Spent BWR fuel	0.14 x 0.14 x 4.383	32 972	1 940		
Spent PWR fuel	0.21 x 0.21 x 4.103	3 865	552	12 800	BS/SFL 2
Other spent fuel (MOX, Ågesta, Studsvik)	Various	641	21		
Core components in storage canisters	0.8 x 0.8 x 4.6	450	450	19 700 *	BS/SFL 5
Reactor internals in storage canisters	0.8 x 0.8 x 4.6	555	555		
Operating waste from CLAB to silo	1.2 x 1.2 x 1.2	1 150 2 370	80 170	2 000 4 100	SFR 1 SFL 3
Operating waste from CLAB to rock vault	1.2 x 1.2 x 1.2	290 400	20 30	500 700	SFR 1 SFL 4
Waste from Studsvik to silo**) (MOX, Ågesta, Studsvik)	$\phi$ 0.6, L=0.9 1.2 x 1.2 x 1.2 $\phi$ 0.6, L=0.9	3 750 690 4 500	50 50 70	1 200 1 200 1 500	SFR 1 SFR 1 SFL 3
Waste from Studsvik to rock vault**) (MOX, Ågesta, Studsvik)	$\phi$ 0.6, L=0.9 1.2 x 1.2 x 1.2 ISO-cont.	8 750 690 200	150 50 200	2 800 1 200 7 600	SFR 1 SFR 1 SFR 1
Operating waste from encapsulation station to silo	1.2 x 1.2 x 1.2	520	43	900	SFL 3
Operating waste from nuclear power plants to silo	$\phi$ 0.6, L=0.9 1.2 x 1.2 x 1.2	3 375 8 650	45 620	2 500 15 000	SFR 1 SFR 1
Operating waste from nuclear power plants to rock vault	$\phi$ 0.6, L=0.9 1.2 x 1.2 x 1.2 ISO-cont. 3.3 x 1.3 x 2.15	18 200 5 770 750 1 100	350 410 750 365	5 800 10 000 28 500 11 000	SFR 1 SFR 1 SFR 1 SFR 1
Decommissioning waste from nuclear power plants to rock cavern	ISO-cont. etc.	4 800	4 800	100 000	SFR 3
Decommissioning waste from Studsvik to rock cavern	ISO-cont.	100	100	4000	SFR 3
Decommissioning waste from CLAB and BS to rock cavern	2.4 x 2.4 x 2.4	640	640	8 900	SFL 4
Transport containers		50	50	600	SFL 4
Total approximately		105 000	12 600	243 000	

\*) Incl. the grouted-in BWR<sub>3</sub> fuel boxes that are transported with the fuel.

\*\*) Incl. total about 3 500 m<sup>3</sup> of waste within NPP sphere of responsibility.

## APPENDIX 2

### TRANSPORTATION SYSTEM

Handling of the radioactive waste involves a considerable transport undertaking for moving the waste from the sites of production to final repositories. The spent fuel and the core components also have to be transported to and from the interim storage facility. All existing nuclear facilities are located on the coast, permitting sea transports. The site of the final repository for the long-lived waste, SFL, has not yet been decided. In the event of an inland siting of this facility, which is the assumption made in this report, the transportation system will be augmented with a rail link between the SFL and a suitably situated harbour. Existing rail lines will hereby be used to as great an extent as possible.

The transportation system includes transport containers and casks, ship and terminal equipment.

Transport containers holding a number of waste units are used to protect the transport workers and the public against radiation and the load against damage during transport.

The transport cask for spent fuel consists of a cylinder made of thick steel and provided with a neutron-shielding layer and cooling fins on the surface. The ends are protected by shock-absorbers. See Figure A2.1. The cask is designed to resist extreme stresses in accordance with the IAEA's regulations for type B packages. The casks currently being used, TN17/MK2, hold 17 BWR assemblies or 7 PWR assemblies and have a total weight of about 80 tonnes, of which the uranium weight constitutes about 3 tonnes. Larger casks will be used for transports from CLAB to the final repository. During transport, the cask is carried on a transport frame, functionally adapted to the terminal vehicle and the ship's cargo hold.

Intermediate-level waste is transported in radiation-shielding containers, called ATB containers. A common type holds about 20 m<sup>3</sup>, equivalent to 12 waste concrete moulds with a surface dose rate of up to 60 mSv/h. There are also larger containers with thinner walls for waste packages with a lower surface dose rate. The container's transport frame has a design similar to that of the frame for the spent fuel cask, permitting uniform handling, see Figure A2.2.

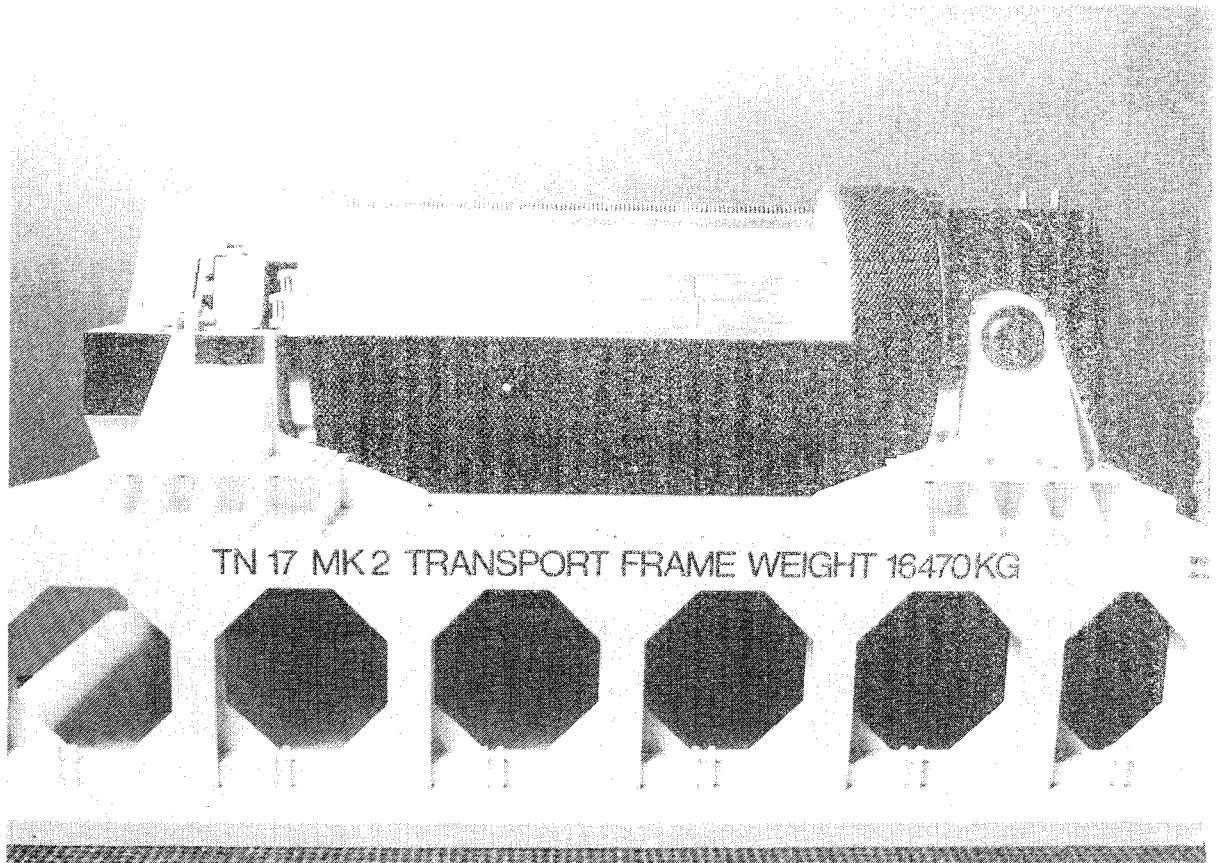

Figure A2.1 Model of TN17/Mk 2 transport cask for spent nuclear fuel.

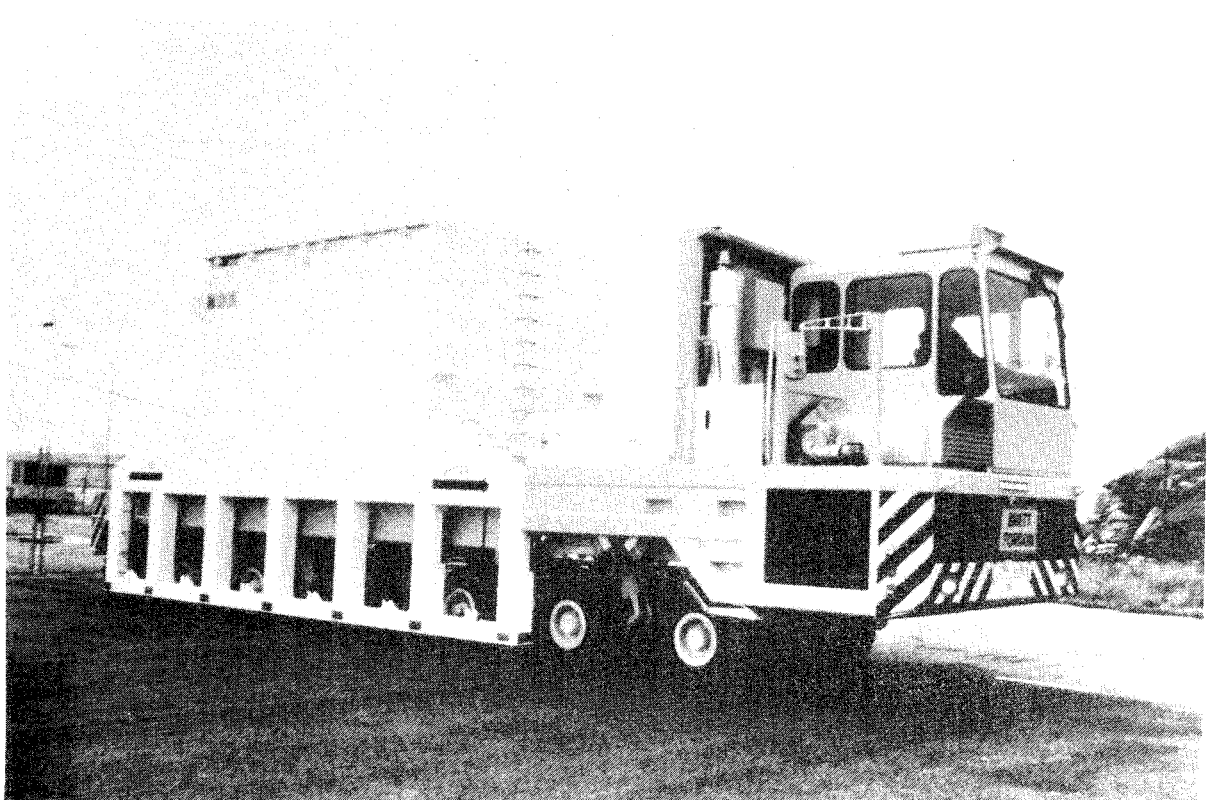

Figure A2.2 Terminal vehicle with ATB-12 K type transport container for intermediate-level waste.

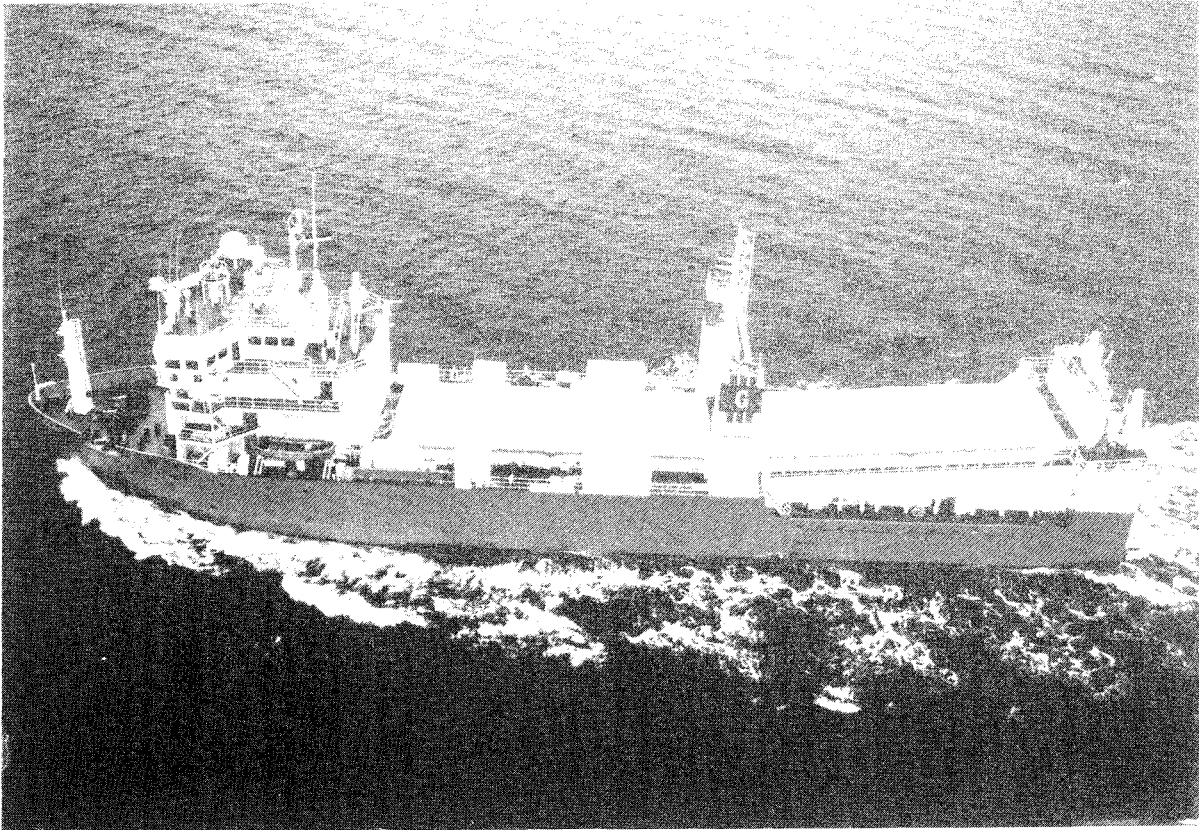

Figure A2.3 M/S Sigyn.

The total weight is max 120 tonnes, of which the waste accounts for about 50 tonnes. Low-level waste from reactor operation and decommissioning is transported in standard ISO containers, which are deposited in the final repository.

Figure A2.2 also illustrates the terminal vehicles that are used. The vehicle consists of a 6-axle unit with separate drive on each wheel pair. The bed can be raised and lowered hydraulically, which is utilized to pick up and off-load the cargo. The vehicle's ground speed is low, less than 5 km/h, and it is therefore only used for short hauls.

The sea transports are carried out primarily by a specially-built ship, M/S Sigyn, see Figure A2.3. The ship is a combined roll-on/roll-off and lift-on/lift-off vessel, which means that the cargo can either be driven in over the ramp or lifted down through the cargo hatches into the cargo hold. The ship has a deadweight tonnage of 2 000 tonnes and an overall length of about 90 m. Payload capacity is 1 400 tonnes. The transport casks are placed in fixed positions in the hold and the transport frames are lashed to the vessel. Corner and side fittings welded to the deck prevent shifting of the cargo.

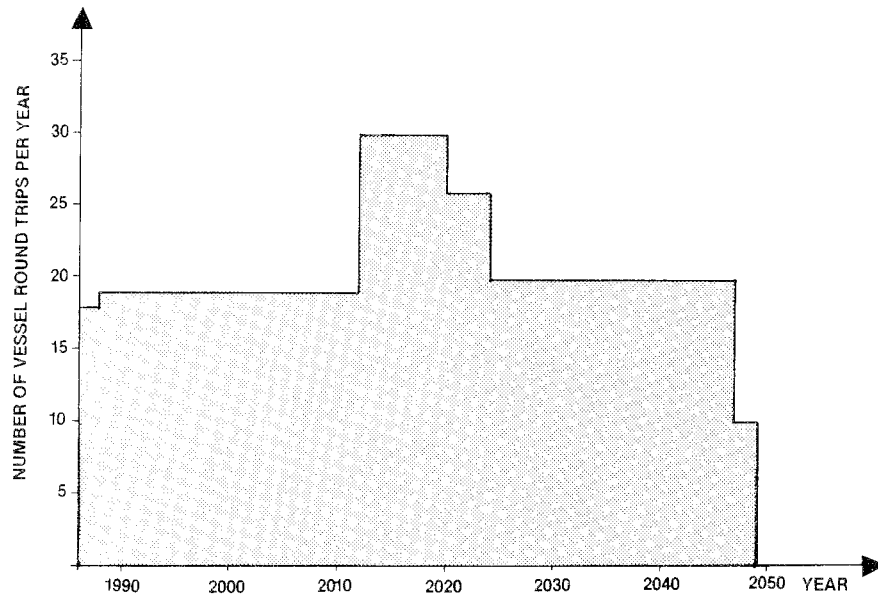

Figure A2.4 Transports of radioactive waste. Number of ship trips per year.

The ship is equipped with extensive safety systems for radiation and fire protection and, in the event of an accident, systems to facilitate search and salvage.

The transportation system, which has been in service since 1983, has transported 57 tonnes of fuel to France and 1100 tonnes to CLAB up to December 1989. Approximately 4 000 m<sup>3</sup> low and intermediate level waste from reactor operation has been transported to SFR. The system will be in operation until the last of the decommissioning waste from CLAB has been transported to the SFL. This is assumed to occur in 2048. The number of ship trips per year during the operating period is shown in Figure A2.4. Owing to the length of the operating period, about 60 years, it is assumed that the ship will have to be replaced twice.

## APPENDIX 3

### CENTRAL INTERIM STORAGE FACILITY FOR SPENT NUCLEAR FUEL, CLAB

#### DESIGN

CLAB, situated at the Oskarshamn nuclear power station is an interim storage facility for spent nuclear fuel. The purpose of the facility is to provide an efficient means of storing all spent fuel discharged from the Swedish nuclear power plants pending encapsulation and final disposal. The storage capacity at the CLAB facility will therefore be sufficient, when fully expanded, to accommodate a fuel quantity equivalent to about 8 000 tonnes of uranium.

In addition to the spent fuel, certain replacement items (core components) and decommissioning products that have been activated during reactor operation will be stored in CLAB pending future final disposal.

CLAB consists of an above-ground complex and an underground complex housing the storage pools, see Figure A3.1.

The facility is being built in two phases. Phase 1 was taken into operation in 1985 and encompasses the above-ground complex plus a rock cavern with storage pools originally designed for approximately 3 000 tonnes of uranium. By the introduction of a new type of storage canister, the capacity will gradually increase to approximately 5 000 tonnes. In phase 2, the storage section will be expanded to full capacity. This will take place in the late 1990s. In this report, it is assumed that phase 2 will be implemented by construction of a rock cavern parallel to the existing one. See Drawing 3.1.

The above-ground complex consists of several interconnected buildings, see Figure A3.2. In terms of function, the buildings can be divided into a reception building, an auxiliary systems building and an electrical building. The reception building mainly houses the equipment required to unload and load the transport casks in connection with reception and dispatch of fuel and core components.



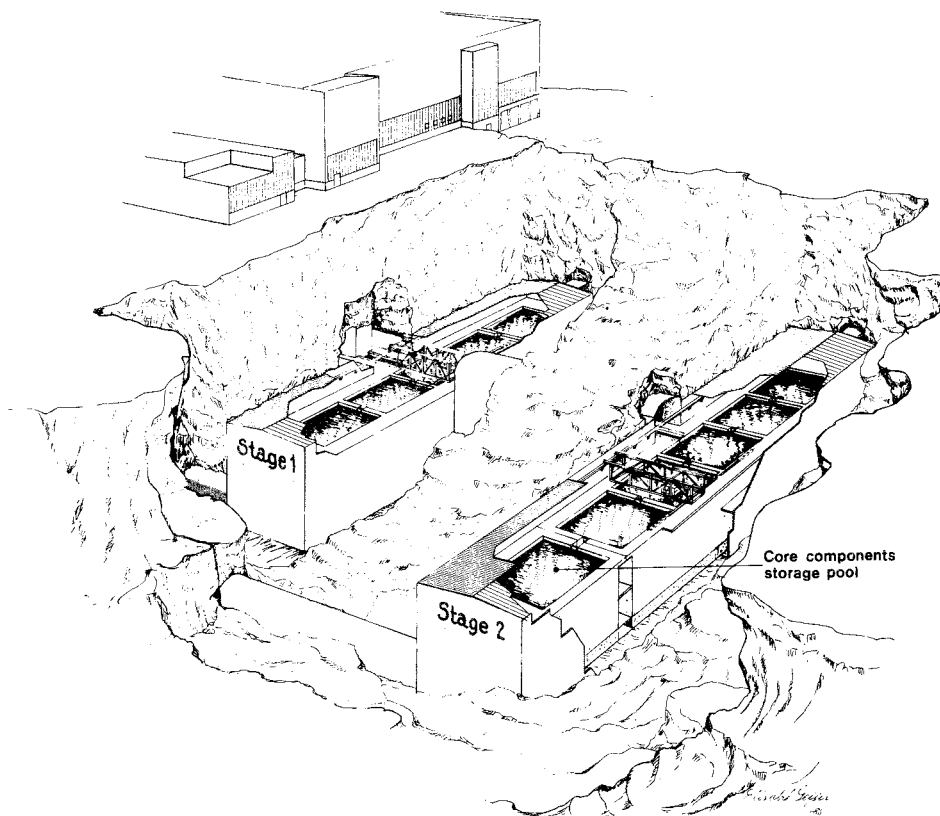

Figure A3.1 CLAB storage section, phases 1 and 2.

All handling of fuel in the reception building, as in the rest of the facility, is made in water-filled pools, which provide good cooling and effective radiation protection for the personnel. The pool block in the reception building contains seven pools, four of which are used for the two unloading lines and the others for temporary storage and for certain other requirements, for example in connection with the receipt of non-standard transport casks and in connection with service.

Connected directly to the reception building is a building that houses auxiliary systems for cooling and water purification, waste handling, ventilation etc. The electrical building houses the operations centre as well as all equipment for power supply, control and monitoring of the facility. Separate passages lead to these buildings from a free-standing office and personnel building.

The storage section consists of rock caverns whose roofs are located about 30 m below the surface. They are reinforced with rock bolts and lined partly with concrete. The rock cavern in the first phase is 120 m long, 21 m wide and 27 m high. It contains four storage pools, each with 300 storage positions for the transportable storage modules (canisters) plus a smaller central pool connected to an elevator shaft

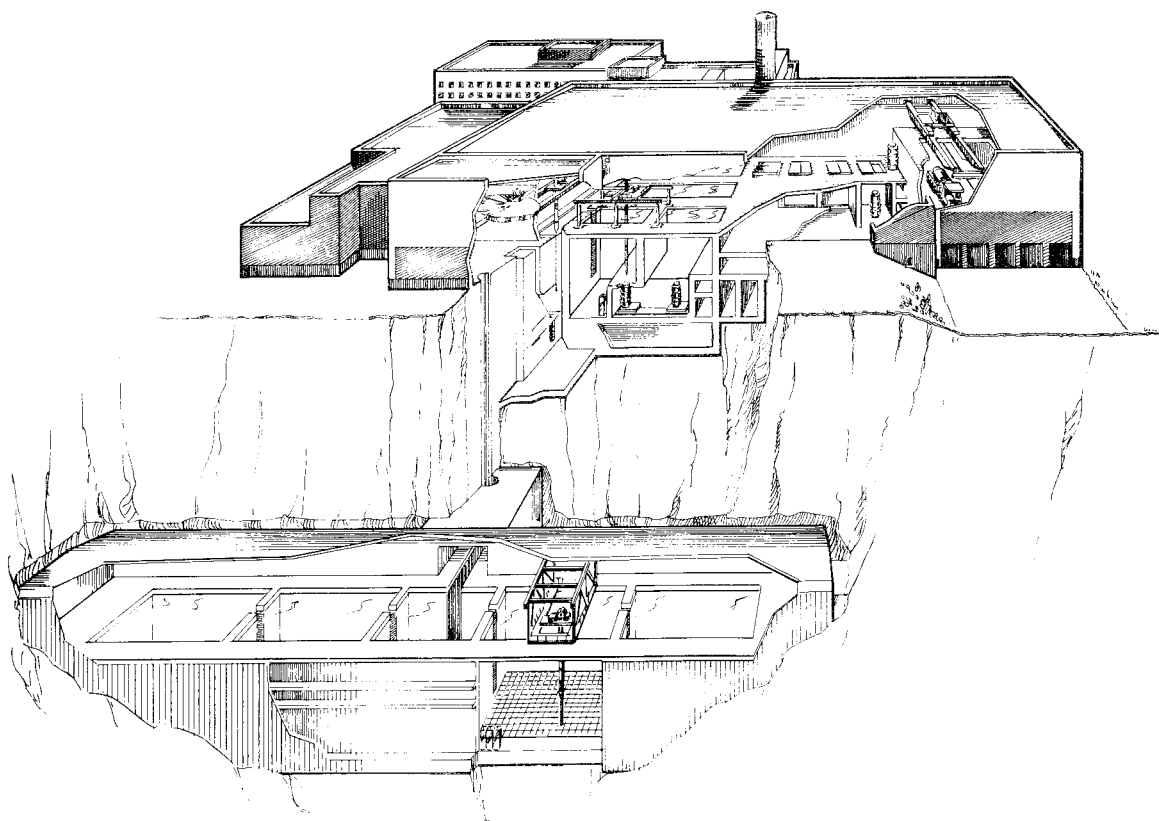

Figure A3.2 CLAB phase 1.

via a transport channel. The pools are made of reinforced concrete and lined with stainless steel. Each pool holds 3 000 m<sup>3</sup> of water and can accommodate about 1 200 tonnes of uranium.

The second building phase will comprise a rock chamber parallel to the existing one. The basic design will be the same. One pool will be reserved for core components.

### OPERATION

When a fuel transport arrives at CLAB, the transport vehicle with the cask is driven into the air lock underneath the reception hall floor. The cask is inspected, and after removal of the shock absorbers it is coupled to one of the main overhead cranes by means of a lifting frame. The cask is raised upright and lifted through the hatch in the roof of the air lock for transfer to one of the cooling cells.

The cask is provided with a protective skirt in order to protect the cooling fins against mechanical damage and contamination during

the subsequent reception work. The annular space between the cask and the skirt is filled with water, which is circulated via hoses connected to a separate skirt cooling circuit in the cooling system.

The top and bottom orifices in the cask are fitted with special tools by means of which the sealing plugs can be unscrewed. The tools are fitted with hoses which are also connected to the cooling system. Through the circulation circuit that is established, the cask can be filled with water and cooled to a low temperature. The circulating water also flushes out the cask, thereby reducing the quantity of loose active particles in the cask. The particles are collected on a filter in the cooling system, which is back-flushed as needed to a replaceable filter cartridge.

The outer cover on the cask and the circular flange that locks the cask cover are removed. Adapters for adapting the cask to the unloading pool are fitted to the top of the cask and to the cask cover.

The cask is now ready for transport to the cask pool, where, in two stages, it is lowered and placed on a transport wagon that runs on rails in the bottom of the pool. The wagon takes the cask into a channel that leads in under the unloading pool. In the roof of the channel is a connection device that is lowered down onto the cask. The purpose of the connection device is to keep the uncontaminated water in the cask pool separated from the water in the unloading pool.

The cask is opened by a pole crane, which lifts up the cask cover and the sealing plug in the connection device as a single unit. The pole crane travels on an overhead track that rests on columns along the pool.

The pole crane is provided with a grab for the fuel assemblies, which are then lifted up out of the cask, one by one, and transferred to the fuel canister.

From here on, the canister constitutes a transport unit for the continued handling.

Several types of canisters are used in the facility to cover the various storage needs. A canister for BWR fuel holds 16 fuel assemblies, while a PWR canister holds five.

From the end of 1991 new canisters will be introduced that will be able to take 25 BWR fuel assemblies or 9 PWR fuel assemblies.

Another pole crane whose working range covers all pools in the reception section is used to transport canisters from the unloading pool to the fuel elevator. The canisters are taken in the elevator down to the storage section.

In the storage section, the canister is transferred from the elevator to its storage position by an overhead handling crane. The empty casks are transported back to the same cooling cell where they were previously cooled. The water in the cask is drained, and after the removed cask components are fitted, a final inspection is carried out of the integrity of the casks before they are removed from the facility.

Filling of transport casks for removal of fuel from CLAB follows the same procedure as unloading.

The permanent personnel force during operation is about 50 persons. In addition, service personnel are currently being utilized mainly from OKG's regular operating organization. On average, they are equivalent to about 60 full-time employees. During periods when no loading-in or loading-out is taking place, the work force can be reduced by about 15 men.

After all fuel and other waste has been removed from CLAB to final disposal, the above-ground complex will be dismantled, along with those parts of the storage pools that have become active. Radioactive waste is sent to the SFL.

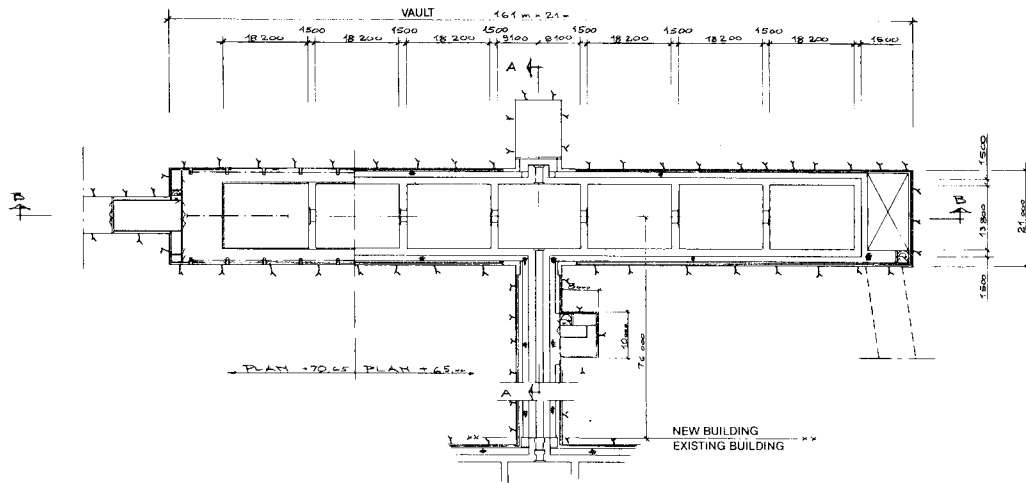

PLAN

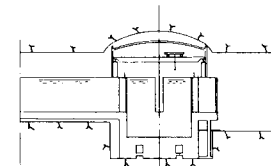

SECTION A-A

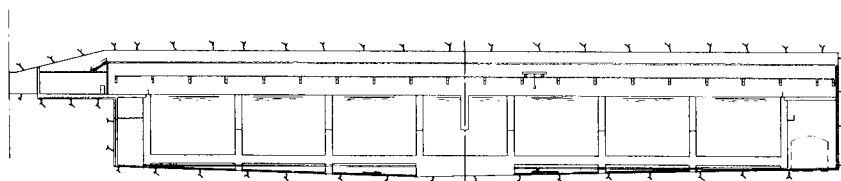

SECTION | B-B

DRAWING 3.1

CLAB II  
STORAGE BUILDING  
7 POOLS  
DRAFT

Scale	1:500
Date	09/56
132-12-001	

Drawing 3.1 is the property of the Ministry of Water Resources and is not to be reproduced without the written permission of the Ministry.

Rev.	Issued For	By	Date

--	--

## APPENDIX 4

### FINAL REPOSITORY FOR LONG-LIVED WASTE, SFL AND ENCAPSULATION STATION FOR SPENT FUEL, BS

#### GENERAL

The spent nuclear fuel and other long-lived radioactive waste will be finally disposed of in geologic repositories located in the bedrock approximately 500 m below the ground surface. Four types of repositories are planned, intended for different types of waste.

- SFL 2, intended for encapsulated spent fuel. The repository consists of tunnels where the waste is deposited in holes drilled in the tunnel floor.
- SFL 3, intended for transuranic waste and intermediate-level operating waste. The repository consists of concrete troughs placed in a rock vault.
- SFL 4, intended for decommissioning waste, mainly from CLAB and BS. The repository consists of the tunnels and other rock chambers that are left over after filling of SFL 3 and 5 are concluded.
- SFL 5, intended for core components and reactor internals embedded in concrete moulds. The repository consists of tunnels in which the moulds are stacked and grouted with concrete.

Prior to deposition in the repository, the spent fuel will be encapsulated in copper canisters. This takes place in the encapsulation station, BS. At present, it is assumed that BS will be cosited with SFL. Cositing means that the fuel can be taken directly after encapsulation via an elevator shaft down to SFL 2. The arrangement is illustrated in Figure A4.1.

At present, it is assumed that SFL 3-5 cannot be located immediately adjacent to SFL 2, but will be situated approximately 3 km away. The repositories are reached via shafts and a separate reception building is provided on ground level. SFL 3-5 are thus located outside the area shown in Figure A4.1, but are included in the same organizational unit.

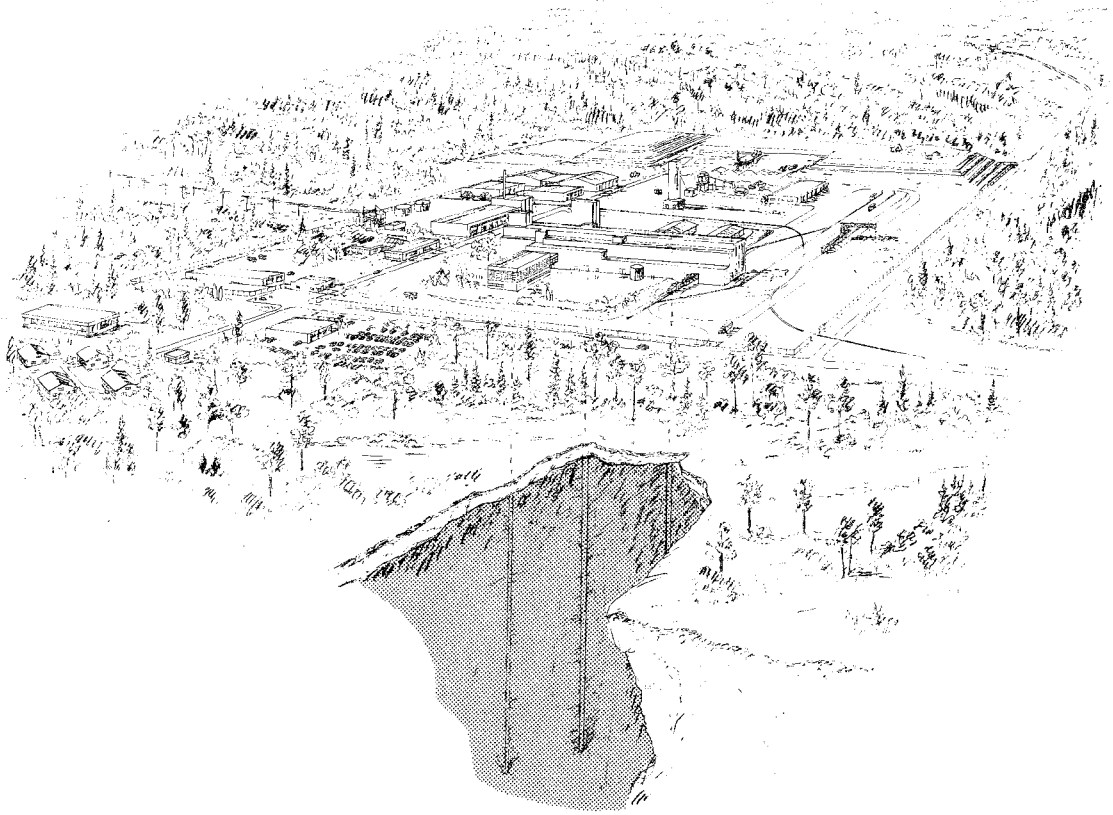

Figure A4.1 SFL 2 - overview.

A total of about 350-400 men will be employed at the SFL and the BS during the operating period. Approximately 800 men will be required during the construction period.

#### COMMON FACILITIES

Through cositing of BS and the different SFL repositories, a number of supply and service systems can be made common. This applies above all to the transportation system and the station site.

The waste coming from CLAB and Studsvik is transported by ship to the nearest available harbour that can be considered suitable for this type of transport after certain improvements of the navigation channel and the quay area. In the cost calculation, the harbour has been supplemented with a separate ro/ro quay, a widened and deepened approach channel, harbour apron, guard house etc. The waste is then transported in its containers by rail to SFL. It is hereby assumed that 50 km of railway will have to be built. In addition, rolling stock will have to be acquired, ie locomotives and specially-built cars.

The layout of the station site is illustrated by Drawing 4.1. Aside from BS, which is the dominant building, there will be personnel facilities including housing, goods reception station, workshops, vehicle service, concrete station with crusher, storage and handling of bentonite etc. Water supply and sewerage will also be required.

Facilities for handling of the sealing materials include the following functions. Bentonite granulate will be stored indoors (in a silo), along with the bentonite/sand mixture that will be used to seal tunnels and rock caverns. Storage capacity is equivalent to approximately one year's operation (during the deposition phase). It is assumed that the material will be transported to the site by rail. Some of the bentonite is compacted in a high-pressure press and moulded into blocks for filling out the deposition hole around the copper canister or for other purposes, eg plugging of tunnels and shafts. The remaining bentonite is used in the sand/bentonite mixture (15/85) which is utilized as backfill. Mixing is carried out above ground and the material is then packed in containers that are taken down to repository level by elevator via the central shaft.

The operating staff for the common facilities is estimated to amount to about 150 men, including all administrative personnel for the SFL-BS.

After completed deposition, all facilities will be dismantled and the site will be restored as close to the original state as possible. Radioactive decommissioning waste, primarily from BS, will be placed in SFL 4. All activities are estimated to be concluded by the year 2051.



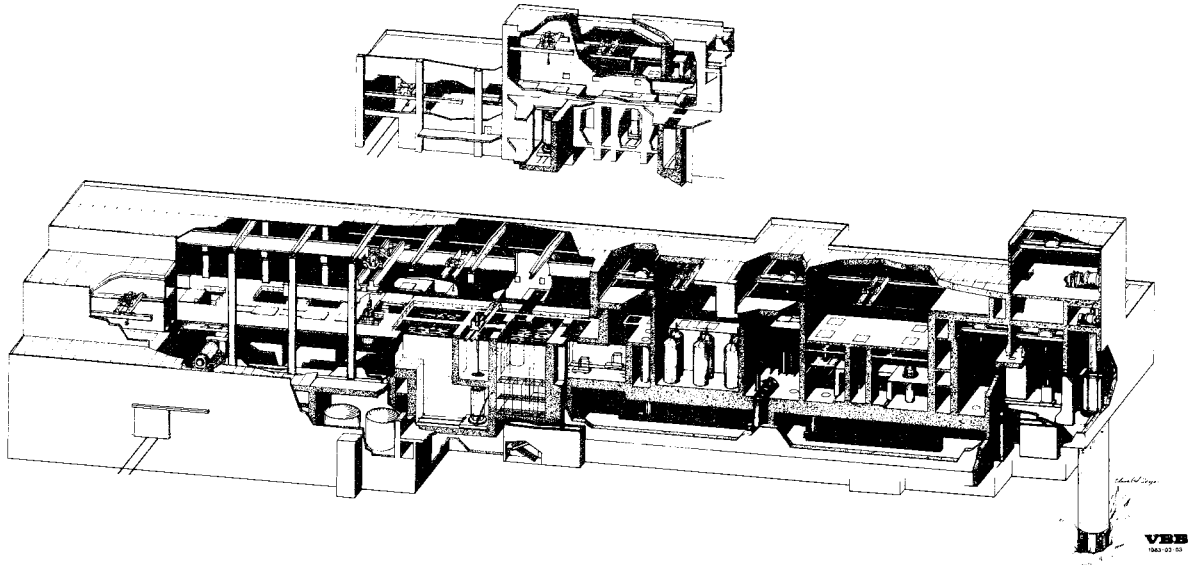

Figure A4.2 Encapsulation station.

## ENCAPSULATION STATION FOR SPENT FUEL, BS

### Layout

The spent fuel will be received and encased in copper canisters in the encapsulation station, BS, Figure A4.2. The design of a copper canister is illustrated in Figure A4.3. BS is designed for an encapsulation rate of one canister/day, equivalent to 210/year. The total number of copper canisters will be about 5 700.

BS will also be a receiving station for core components and reactor internals, which are embedded in concrete moulds in a special part of the facility. A large portion of the core components consists of fuel boxes that are transported together with the fuel. The design of the mould is illustrated in Figure A4.4.

The layout of BS is illustrated by Drawing 4.2-4.5. The total building volume is 250 000 m<sup>3</sup> and the length of the building is about 170 m. In order to meet demands on radiation shielding and ventilation tightness, the building is made primarily of concrete.

The facility can be divided functionally into the following main parts:

- Arrival and receiving section, where unloading and fuel handling take place. Also included is an active workshop for repairs of transport casks.
- Encapsulation and dispatch section for fuel, with elevator down to the final repository.

- Encapsulation section for core components (concrete casting).
- Service section, located alongside the encapsulation section and containing stores, lead melting equipment etc.
- Auxiliary systems section, primarily for cooling and purification systems as well as for internal handling of active operating waste.
- Electrical and control section.

A side building houses personnel and office quarters as well as a superstructure and service systems for the central elevator shaft down to the final repository. See Drawing 4.6.

### **Operation**

The handling procedure for encapsulation of spent fuel and core components is illustrated by the flow diagram in Drawing 4.2. The handling lines are duplicated in order to permit continuous operation in the event of operational disturbances. Active material is handled by remote control with monitoring via TV or radiation-shielded windows.

Handling of spent fuel proceeds as follows, in brief. The railway car with the transport cask is driven into the encapsulation station's arrival hall, where it is washed down, after which the cask's mounts and shock absorbers are removed. The cask is then lifted up and placed in a washing and cooling cell, where hoses are connected and the cask is flushed out. The outer lid is removed.

The cask with undone lid screws is placed vertically in the water-filled cask pool on a railbound wagon. The wagon is driven sideways so that the cask opening can be connected to an opening into the unloading pool. The cover in this opening is lifted away, accompanied by the cask lid. The connection between the transport cask and the pool opening is normally tight. If there is any leak, however, the slight pressure difference that exists between the water in the two pools will force the leakage water from the cask pool into the unloading pool. In this way, contamination of the outside of the cask can be avoided to as great extent as possible.

The cask's contents of fuel assemblies are transferred to a fuel rack in the buffer pool. The BWR assemblies are thereby lifted in their boxes. The positions in the rack are spaced with due regard to the risk of criticality.

After unloading is completed, the lids are put back and the cask is transported out and moved to the flushing pit for flushing, water drainage and attachment of the lid. If the cask is without defect, it is then lifted back onto the railway car. Otherwise, it can be lifted

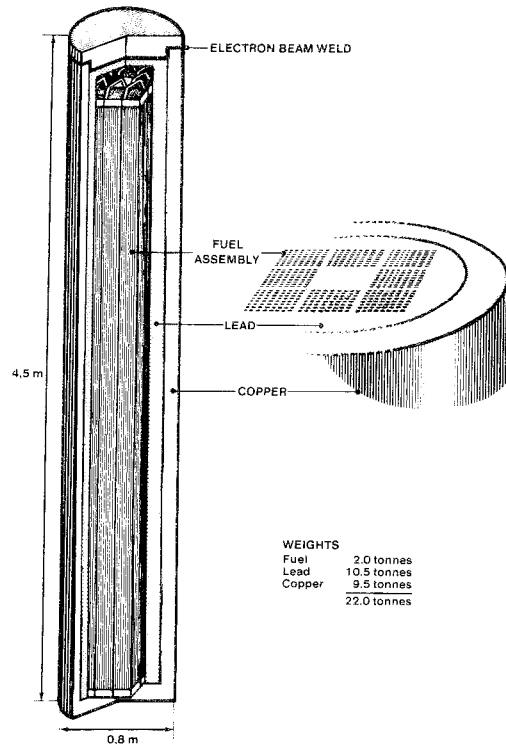

Figure A4.3 Welded copper canister.

via an opening in the floor of the receiving hall down to the active workshop for repair of the defects.

Further handling of the fuel assemblies takes place in the buffer pool. The fuel bundles are moved without boxes from the fuel rack and placed in a rack specially designed for the copper canister. The rack with fuel assemblies is transferred via the air lock pool into the encapsulation section's receiving cell.

The boxes remain in the racks. They are taken via another air lock pool into the section for grouting of core components.

In the receiving cell, the copper rack with fuel assemblies is lifted up out of the air lock pool and allowed to drip dry for a short time. The lifting mount consists of the centre tube in the copper rack. The same tube is later used to distribute the lead during lead casting.

An empty copper canister is transferred via the cooling cell into the encapsulation section and placed in one of the transport wagons. At this point, the canister has an external lip that serves as a lifting mount. Later when the lid has been welded on, this lip is machined off.

The transport wagon with canister is positioned underneath the receiving cell and the fuel is lowered into the canister. The wagon is then moved to a furnace position, and the canister is taken up into the furnace, which is sealed. During the heating-up phase and vacuum pumping, the fuel is dried completely. The canister is filled with molten lead, which is allowed to solidify slowly. The canister is then transferred to the cooling cell, where it is allowed to cool for about 4 days.

After cooling, the canister is transferred to the machining cell, where the top surface of the lead and the canister is machined to the necessary smoothness. Chips and the like are collected for subsequent encapsulation. After machining, the lid is placed on the canister and inspected, after which the canister is transferred to the welding cell.

The canister lid is welded on by means of electron beam welding in a fully automatic process. After welding, the canister returns to the machining cell, where ultrasonic inspection is carried out. If the weld is approved, the lifting lip is machined off and the canister is taken to dispatch inspection. All lifts are subsequently performed with the aid of a lifting recess in the top surface of the lid. If the weld is not approved, the canister is cut open and a new lid is welded on. The old lid is discarded after thorough decontamination.

From the machining cell, the finished canister is transferred to the dispatch section, which begins with an inspection and washing position. The canister is then placed in an elevator car and taken down to the final repository.

The core components and reactor internals are assumed to come from storage in CLAB either, like the boxes, together with the fuel or separately in a special transport cask similar to the fuel cask.

The boxes are handled as follows. When a fuel cask is emptied, the fuel assemblies, with boxes, are lifted out of the cask and placed in a fuel rack in the buffer pool. When the fuel assemblies continue in the handling chain to encapsulation, the boxes remain in the rack. The rack holds 49 boxes, ie the same number as the maximum that can be embedded in a mould. In all, the buffer pool contains positions for 12 fuel racks.

From the buffer pool, a smaller air lock pool leads into the casting section. A transport wagon with room for one fuel rack runs along the bottom of this pool into the mould filling cell. There, the rack is lifted up out of the pool and placed in a pit where it is allowed to stand and run off. The boxes can then be picked up one by one to be placed in the concrete mould. Handling in the mould filling cell takes place by remote control.

The empty concrete mould with a well-fitting lid is taken into the casting section lying on a transport wagon. The same wagon is used

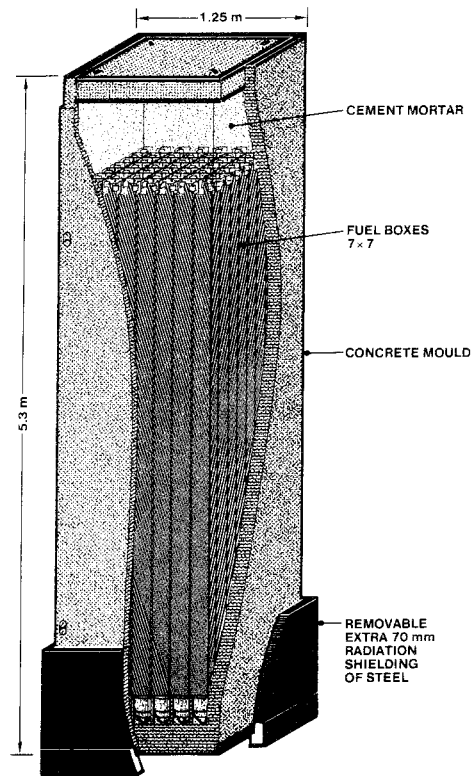

Figure A4.4 Concrete mould with fuel boxes.

later to transport out the finished mould. The mould is raised upright and placed on a railbound transport wagon equipped with hydraulic lift. The wagon is driven up to a filling position situated underneath a floor opening into the mould filling cell. The mould is lifted up for tight connection against the floor and the hatch in the floor is opened.

A steel grid with a thickness and openings suited to the end pieces on the boxes lies in the bottom of the mould. The grid stops about 50 mm above the bottom of the mould, providing the necessary space for distribution of the cement mortar. The boxes are picked up and placed in the mould so that the end pieces stick down into the holes in the grid. This prevents the boxes from falling over and thereby impeding the filling process.

After the mould is full, the floor hatch is closed and the wagon is moved to a casting position, where the mould is connected to a hole in the floor leading into the casting cell. The mould is filled with cement mortar up to about 5 cm below the lid lip. When the mortar has solidified, the mould is moved to the lid application position.

After application of the lid, the empty space in the mould is filled up with injection grout.

The mould is then turned to the horizontal position, placed on a transport wagon and driven out to a waiting railway car or truck for further transport to the final repository in SFL 5.

Other metal components to be embedded in moulds consist of different replacement parts, mainly control rods and detector probes, but also of decommissioning products from the internal parts of the reactor vessels.

These are transported in a transport cask of simpler design. Unloading takes place directly in the mould filling cell, where the cask is connected via an air lock. Casting and further handling then proceed in the same manner as for boxes. After unloading, the cask returns for decontamination, inspection and dispatch.

In some cases, owing to a higher radiation intensity, the mould must be arranged so that the concrete cover is considerably thicker than the mould wall. This is achieved by placing a peripheral row of boxes around the sides of the mould before the more active material is placed in the mould.

The operating staff at the BS will consist at the most of about 80 persons.

## FINAL REPOSITORY FOR SPENT FUEL, SFL 2

### **Layout**

The final repository for spent fuel is situated approximately 500 m below the surface and can be reached via an elevator shaft from BS. The repository consists basically of a system of parallel deposition tunnels, with a total length of about 40 km, with appurtenant transport tunnels, service areas and shafts to the ground surface, occupying a total surface area of about 1 km<sup>2</sup>. The total area is determined above all by the heat generation in the deposited fuel. Its layout is illustrated in Drawing 4.7-4.9. The waste canisters are deposited in vertical holes drilled in the bottom of the deposition tunnels, a total of about 5 700 holes.

The repository is divided into two or more parts, at level -500, to permit a simple physical separation of the deposition work from other activities, such as excavation and sealing work. The deposition tunnels will be excavated as deposition proceeds. It should be pointed out that the division of the repository as it is shown on the drawings is only schematic. In practice, the configuration of the repository will be adopted to the fracture geometry of the rock. In order to determine this fracture geometry, extensive exploratory drilling will be carried out during the excavation phase.

The repository consists of a central section, containing service areas, located directly beneath the encapsulation station, and a deposition section. The central section provides connection with the ground surface via three shafts:

- The central shaft, comprising the main entrance to the repository for both personnel and materials. The repository is supplied with air, water, electricity etc via this shaft, which contains two elevators.
- The skip shaft, provided with rock hoisting equipment. The skip shaft is the first shaft to be excavated and is accordingly driven in the form of a sunk shaft.
- The waste shaft, with elevator for lowering of the canisters.

There is another shaft at the opposite end of the repository. It normally serves as an exhaust air shaft, but in an emergency it can also be used for personnel evacuation.

The total excavated rock volume is about 800 000 m<sup>3</sup> of which the deposition tunnels account for about 500 000 m<sup>3</sup>. The deposition tunnels have a cross-sectional area of about 14 m<sup>2</sup>, which is a minimum area to permit passage of the deposition vehicle. It is assumed that the deposition tunnels are excavated by means of conventional tunnelling technique with a blasting rate that minimizes cracking of the tunnel walls. Blasting and excavation take place with a certain lead time as deposition proceeds, and in stages of about 4 km tunnel length.

### Operation

Figure A4.5 shows a cutaway illustration of a deposition tunnel with canister after deposition and sealing. The canister is placed in a hole drilled in the bottom of the deposition tunnel. The holes have a diameter of 1.5 m and a depth of 7.5 m and are spaced at a distance of 6.2 m. The drilling procedure is begun by drilling a small pilot hole ( $\phi$ 150 mm) with a core drill in the centre of the assumed deposition position. Based on this hole and its core, a judgment is made as to whether the site is suitable as a deposition site in view of the structure and permeability of the rock. If the judgment is positive, full-face driving is begun, whereby the pilot hole serves as a guide hole.

The copper canister is lowered into the hole by a deposition vehicle, which also picks up the canister at the elevator and transports it to the deposition tunnel. During its handling, the canister lies protected in a radiation-shielded tube mounted on the vehicle. See Figure A4.6.

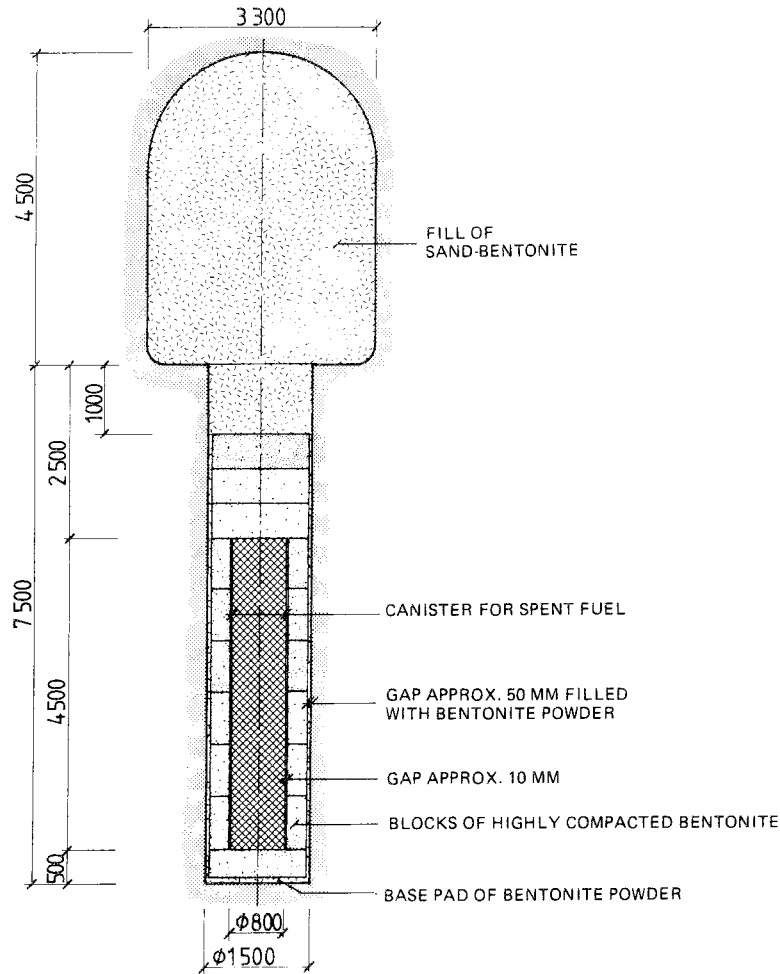

Figure A4.5 Deposition hole with canister and buffer material.

The deposition procedure begins with the placement of all ring-shaped bentonite blocks in the hole, which are then aligned with the aid of a steel dummy. The uppermost bentonite block is provided with a temporary collar of steel. The purpose of this is to protect the bentonite edge against damages while the canister is being lowered. The collar also contains a number of sensors used for automatic centering during lowering of the radiation shielding tube.

The canister is transported down in the elevator from the encapsulation station and is picked up by the deposition vehicle and driven out to the deposition place. After a rough positioning of the vehicle at the deposition hole, hydraulic outriggers are lowered and a fine adjustment of the position is carried out. The radiation-shielding tube is raised to the upright position at the same time it is lowered a couple of metres into the deposition hole, ie down to the uppermost bentonite block. The canister is then lowered and released.



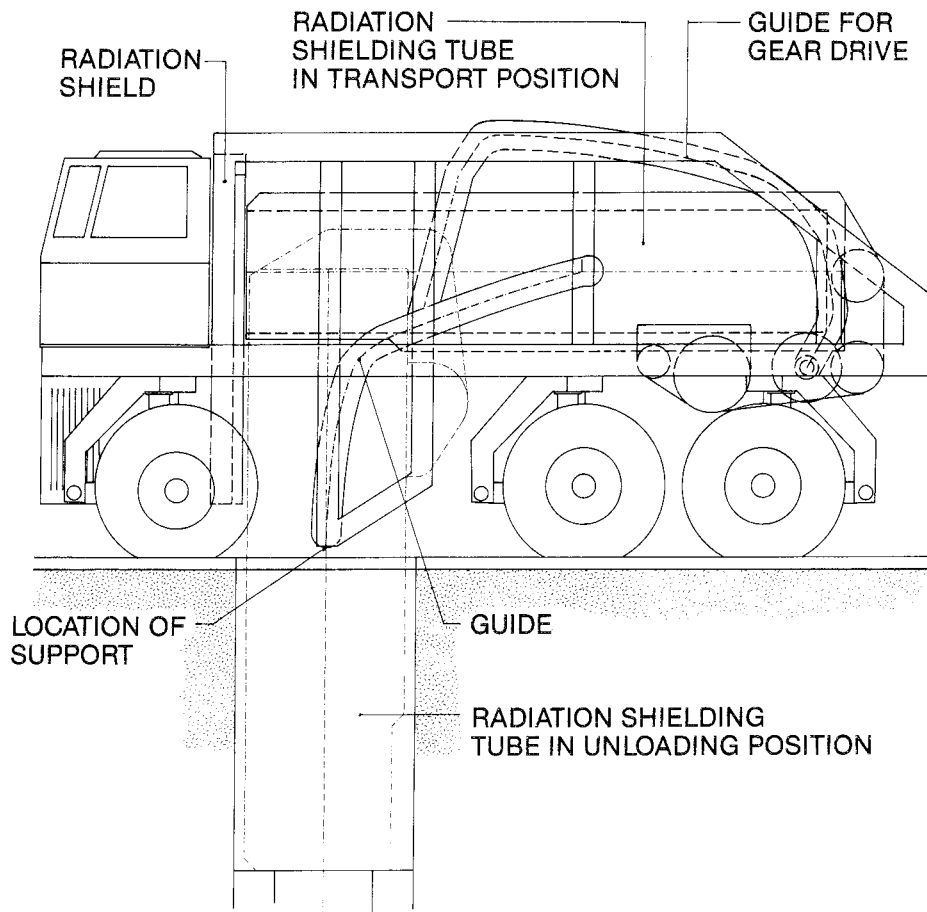

Figure A4.6 Deposition vehicle.

After the canister has been lowered and the deposition vehicle has been driven out of the tunnel, several additional bentonite blocks are placed on top of the canister, rendering the tunnel accessible. The hole is then capped with a watertight seal. The seal is allowed to remain in place until all holes in the tunnel have been finished and backfilling is about to be commenced.

When a number of deposition tunnels are completed, the work of sealing them begins. The temporary seal is hereby removed and the tunnels are filled with sand/bentonite. The tunnel mouths are sealed off with a temporary steel wall, which is removed in connection with backfilling of the central tunnel. See Figure A4.7.

After concluded deposition of all canisters, the entire facility is sealed with sand/bentonite. The shafts are hereby provided with plugs of compacted bentonite in certain sections.

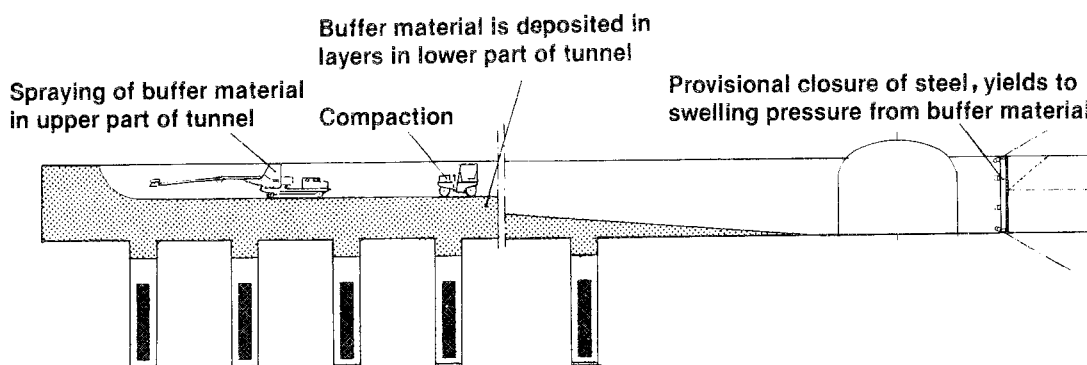

Figure A4.7 Backfilling of deposition tunnel.

At most, the operating staff amounts to about 120 persons, including rock workers for excavation of the deposition tunnels.

#### FINAL REPOSITORIES FOR LOW- AND INTERMEDIATE-LEVEL WASTE, SFL 3-5

SFL 3, 4 and 5 are combined in a common facility and are thus equipped with a number of common areas and functions. The repositories are located at a depth of about 500 m in the bedrock and are reached via three shafts, one of which is intended solely for ventilation. The rock cavern layout is shown by Drawing 4.10. The total rock volume amounts to 120 000 m<sup>3</sup>.

Waste is transported down to the repository level by elevator via one of the shafts, originating from a receiving station on ground level. The elevator is designed to be able to take both small waste packages and other loads, such as the large moulds with core components. The latter weigh about 20 tonnes and comprise the design load for the elevator's capacity. Down in the receiving area at repository level, the waste is transferred to a radiation-shielding transport wagon, which takes it out to the appropriate storage area. The low-level waste can be handled in a simpler manner with a radiation-shielded forklift truck.

#### SFL 3

SFL 3 consists of a number of concrete troughs located in a 80 m long rock vault with a width of 18 m and a height of 21 m. Operating waste from CLAB and BS will be deposited in SFL 3 after SFR 1 has been closed. However, the extensive safety arrangements

around the repository are dimensioned by the disposal of the long-lived Studsvik waste, which has some transuranic content.

The positioning and design of the concrete troughs exhibit many similarities with the silo concept in SFR 1. Thus, the troughs is surrounded by sand/bentonite or by pure bentonite. It is also divided into square cells into which the waste is lowered and grouted. Handling is done by remote control with the aid of a deposition machine of an overhead crane type, which runs on the long walls of the trough. After concluded deposition, the troughs are covered with a concrete lid and all nearby service areas are filled with concrete. Adjoining tunnels are plugged and the cavities against the rock are filled with sand/bentonite.

#### **SFL 4**

SFL 4 is intended to receive the active decommissioning waste from, above all, CLAB and BS as well as transport casks and accordingly enters into function only when all other waste has been deposited. The repository consists of the tunnel system remaining after deposition in SFL 3 and SFL 5 has been concluded and these repositories have been sealed. The waste, which arrives in small steel containers, is placed in the tunnels and backfilled, possibly with crushed rock material. Finally, the shaft is backfilled, whereby a number of plugs of compacted bentonite are installed.

#### **SFL 5**

SFL 5 consists of two tunnels, each about 350 m long and with a cross section of 55 m<sup>2</sup>, in which the concrete moulds with core components are stacked in a lying position five abreast and four high. See Figure A4.8. The handling is made with a remote-controlled straddle carrier. As deposition proceeds, the space between moulds and rock is filled with concrete. The concrete is applied by means of pumping and spraying.

The moulds have dimensions 5.3 x 1.25 x 1.25 m and are designed so that, when they lie stacked in the tunnel, they provide fully adequate radiation shielding through their own concrete thickness and thereby permit access to the tunnel. The total number of moulds is about 2 400.

#### **Receiving station**

The receiving station for SFL 3-5 consists of a reloading station for the waste that is to be deposited and a service station and shaft superstructure for the rock caverns. The layout is shown in Drawing 4.11. The total building volume is about 25 000 m<sup>3</sup>.

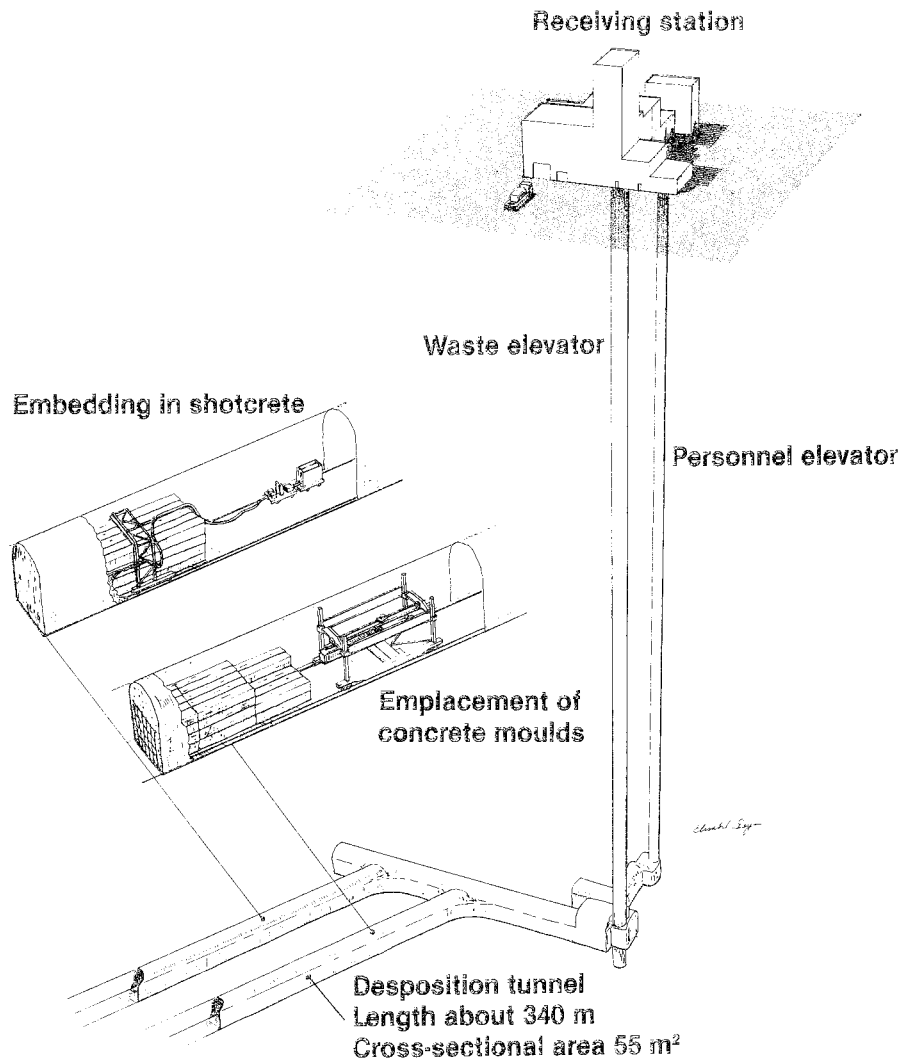

Figure A4.8 Deposition in SFL 5.

The facility can be divided into the following main parts:

- Receiving section including emptying position for waste container from both truck and rail transport.
- Unloading hall with equipment for emptying of transport casks and buffer storage of waste packages.
- Dispatch section, constituting an extension of the unloading hall and served by the same overhead crane. The waste elevator connects to this section.
- Waste elevator.

- Service section for rock caverns, with ventilation equipment etc.
- Control and personnel section including electrical and control room as well as personnel quarters such as office, changing room, radiation protection unit etc. The elevator shaft for passenger transport opens out into the personnel section.

The total personnel requirement for operation of SFL 3-5 is about 60 persons.

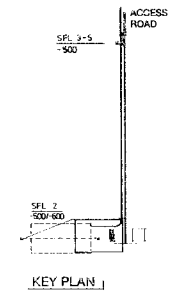
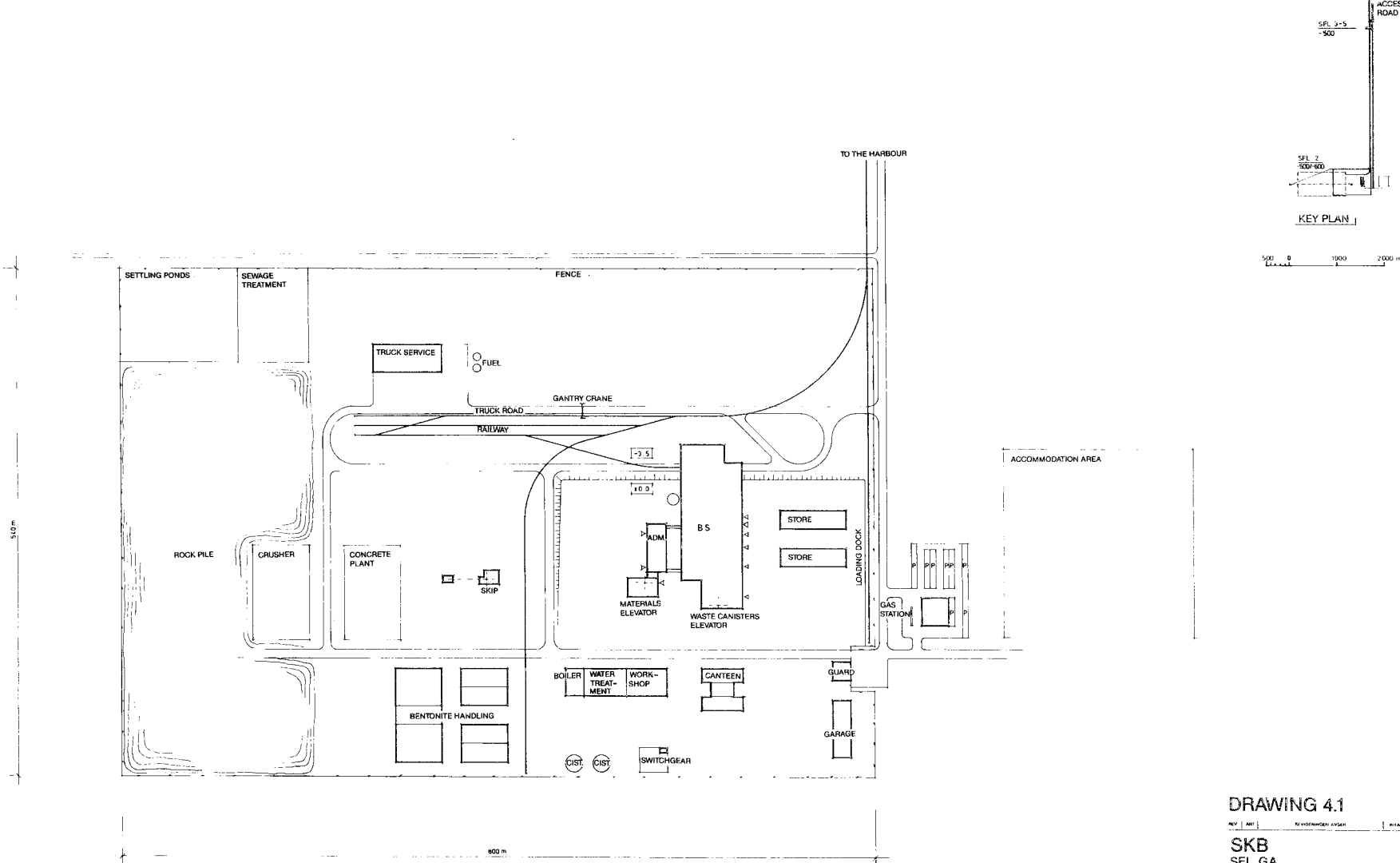

**DRAWING 4.1**

SKB  
SFL GA  
SITE LAYOUT  
GROUND FACILITIES

REVISIONS	NO.	DATE	BY	REASON
AGE	PHU	AGE	AGE	L7970
DRAWING NUMBER			70-86-01	

STOCKHOLM DEN  
86 05 30

**VBB**

BOX: 6038  
102 41 STOCKHOLM S TEL: 08 762 7000

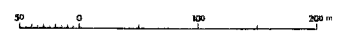

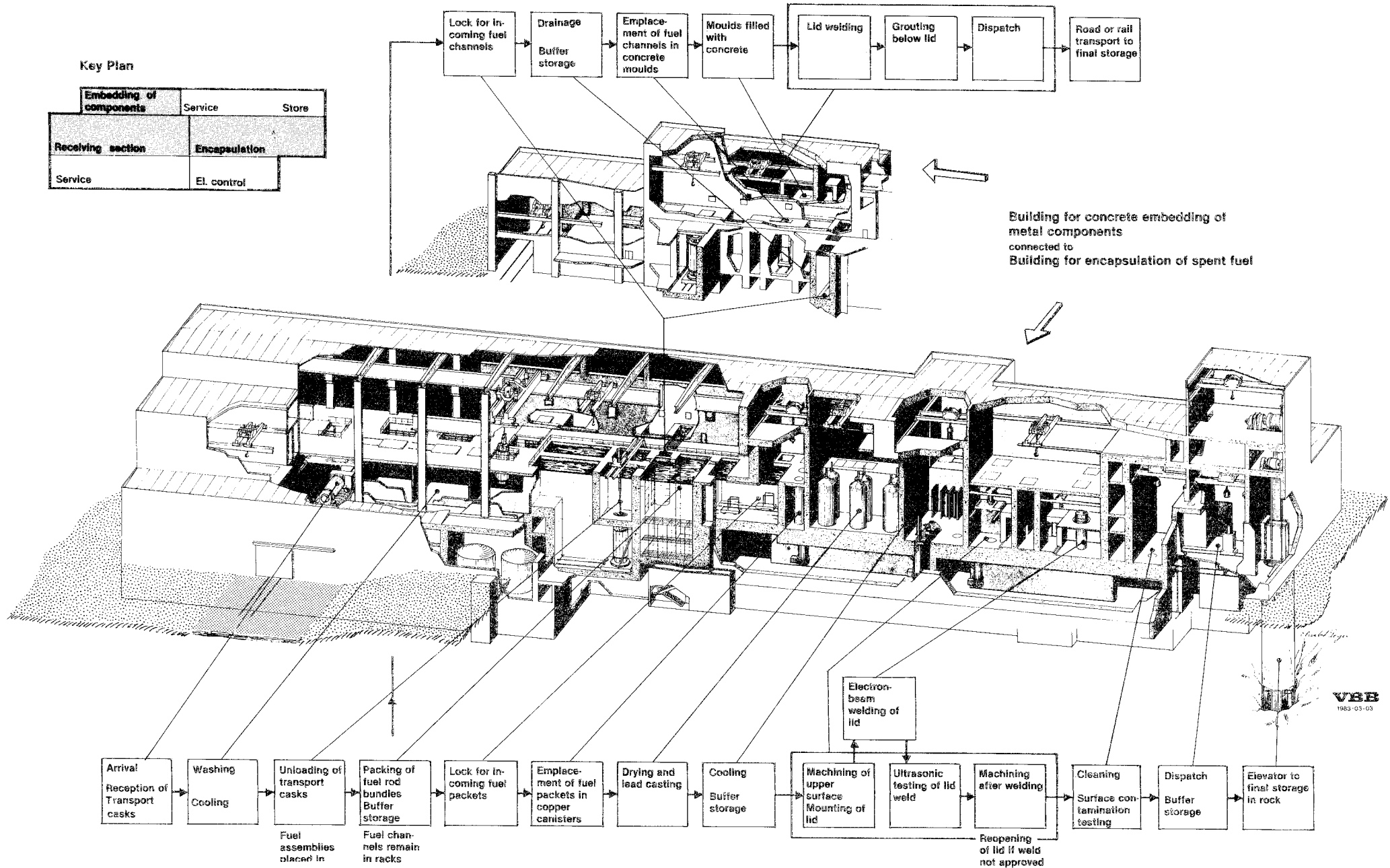

DRAWING 4.2

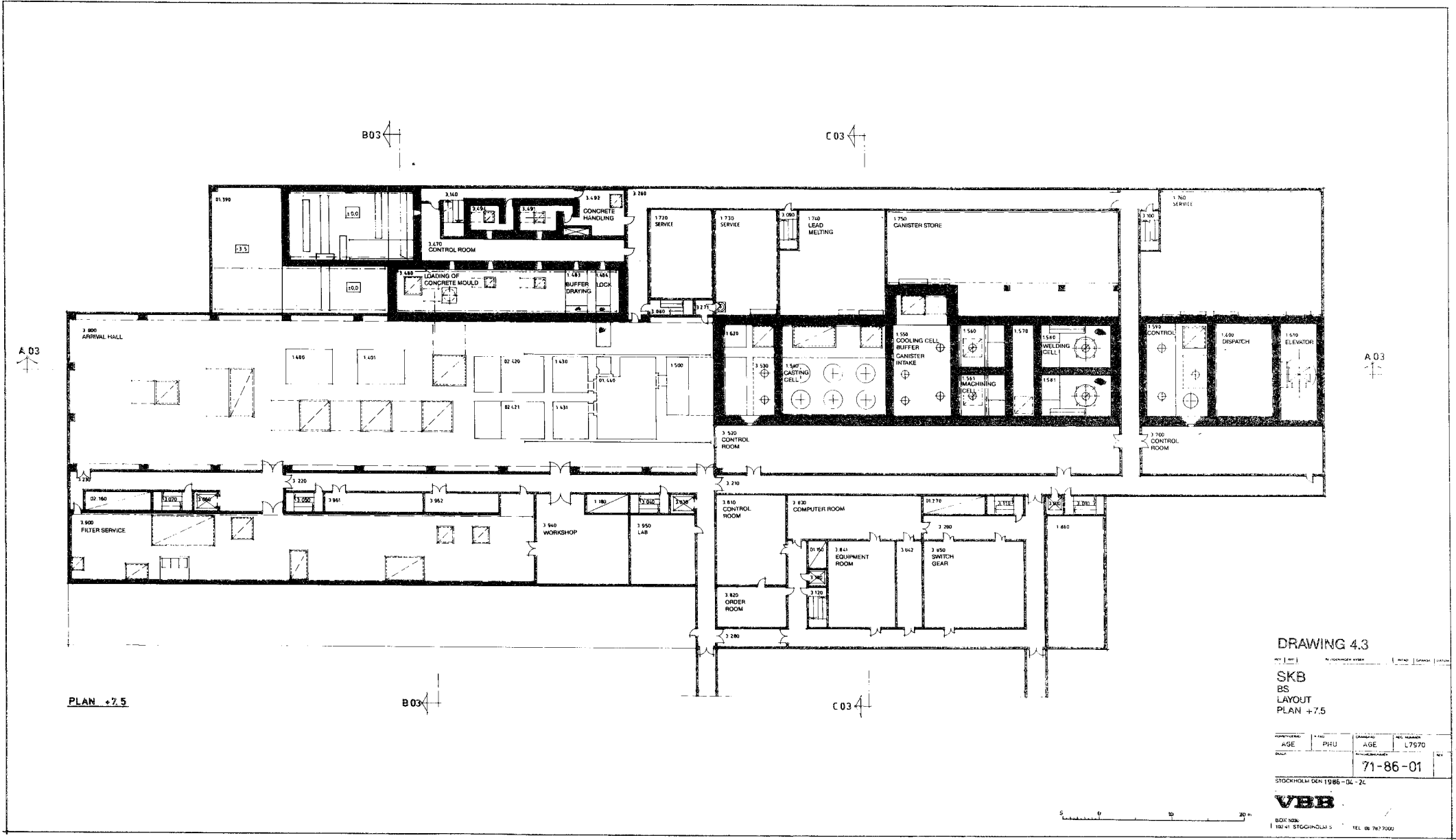

PLAN +7.5

**DRAWING 4.3**

SKB  
BS  
LAYOUT  
PLAN +7.5

AGE	PRU	AGE	L7570
			71-86-01

STOCKHOLM DEN 1986-04-24

**VBB**

BOX 108  
102 41 STOCKHOLM S TEL. 08 767 7000





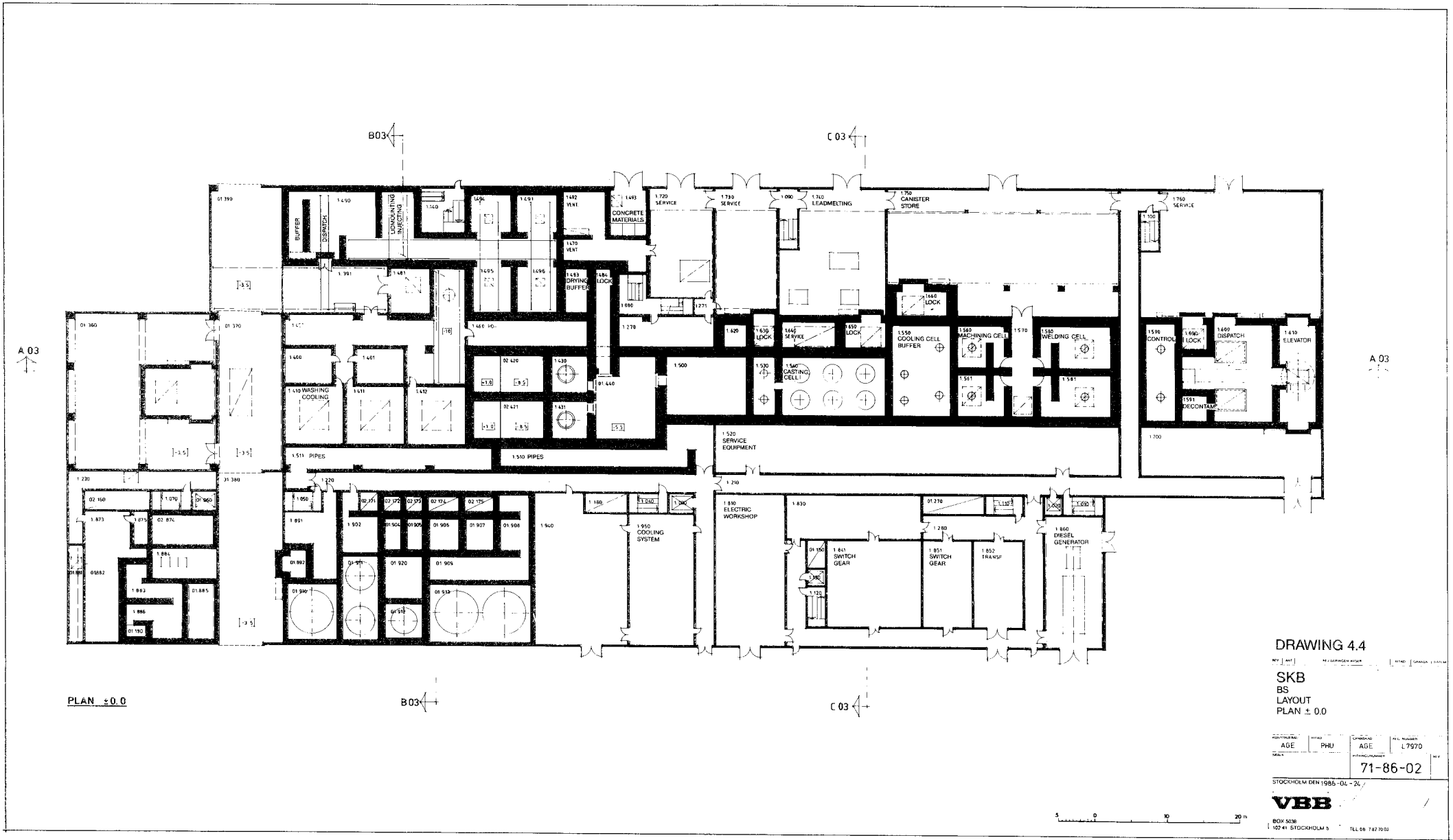

PLAN ± 0.0

**DRAWING 4.4**

SKB  
BS  
LAYOUT  
PLAN ± 0.0

DESIGNED BY	PHU	CHECKED BY	AGE	SCALE	NO.
DATE		DATE	L 7970		

71-86-02

STOCKHOLM DEN 1985-02-26

**VBB**

BOX 5036  
122 41 STOCKHOLM S  
TEL 08 742 7050



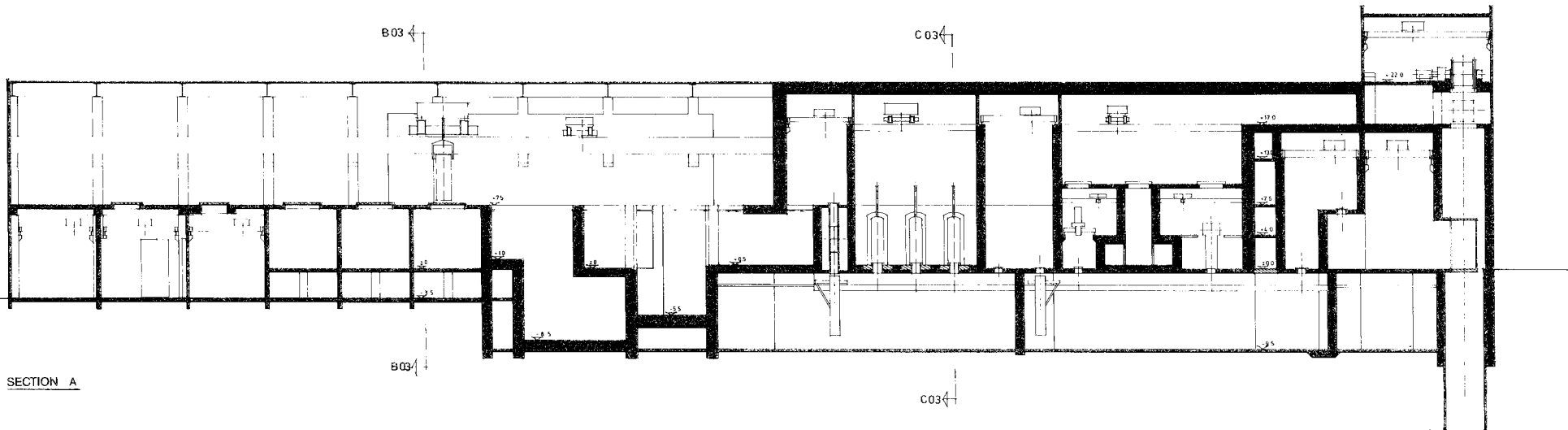

SECTION A

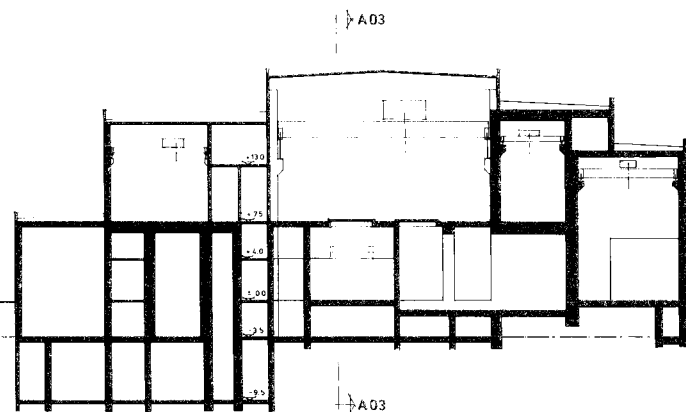

SECTION B

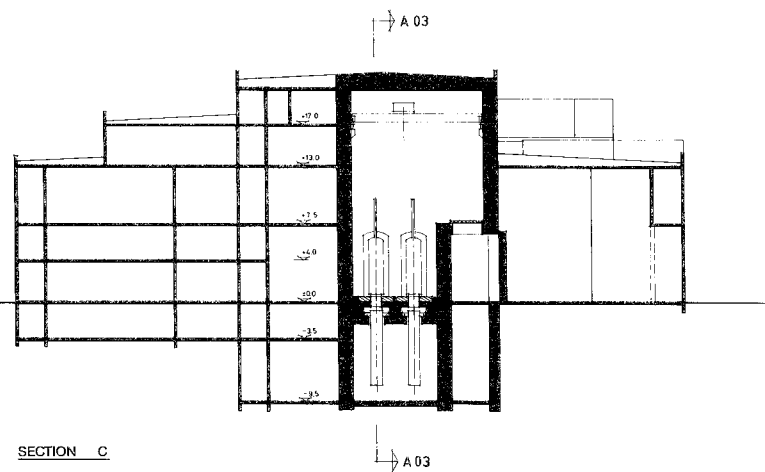

SECTION C

DRAWING 4.5

SKB  
BS  
LAYOUT  
SECTIONS

AGE	PHU	AGE	1.79/70
-----	-----	-----	---------

71-86-03

STOCKHOLM DEN 1986-01-24

**VBB**

BOX 5008  
101 45 STOCKHOLM S  
TEL 08 781 10 00



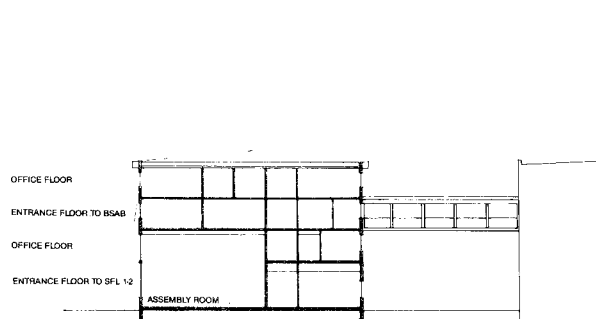

A SECTION

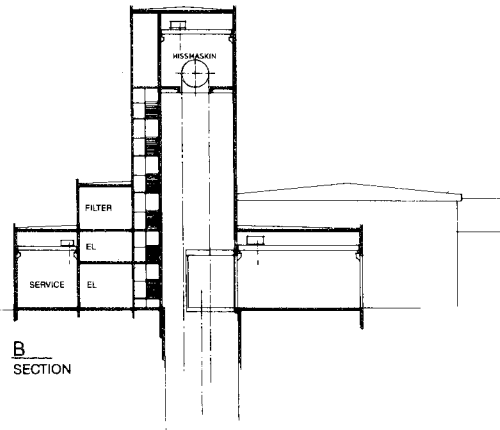

B SECTION

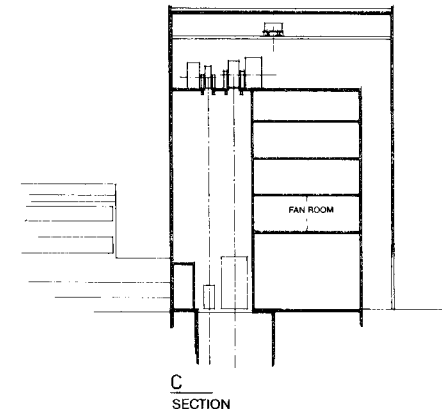

C SECTION

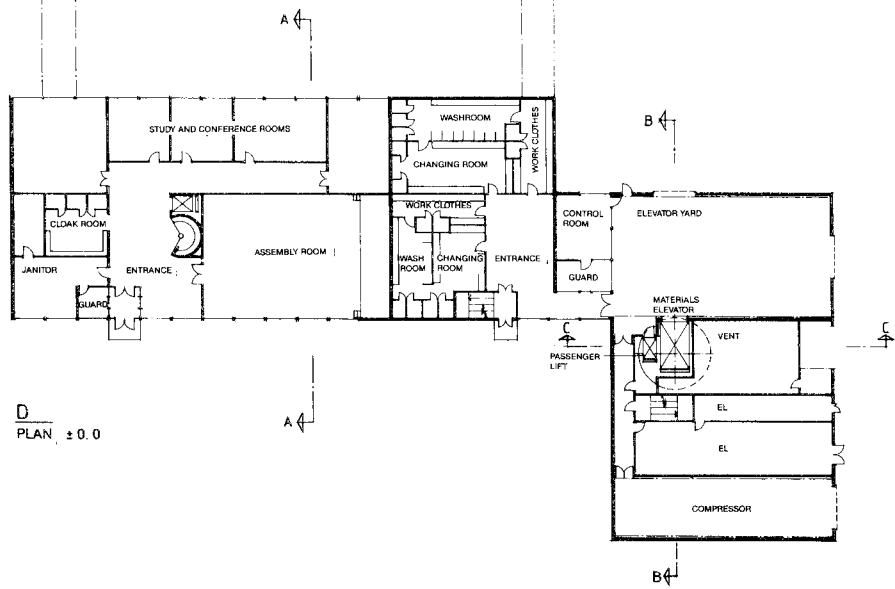

D PLAN ± 0.0

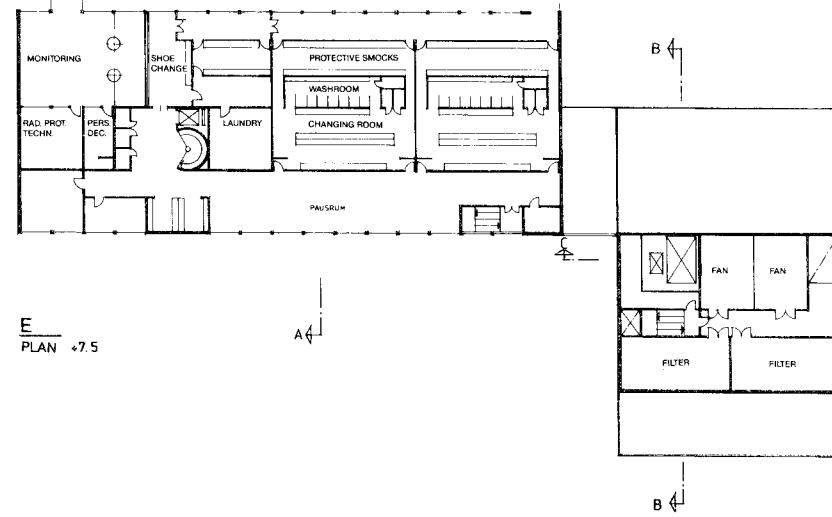

E PLAN -7.5

DRAWING 4.6

SKB  
BS  
ADMINISTRATION BUILDING  
PLANS AND SECTIONS

CONSTR. NO.	DATE	CAUSED	REV. NUMBER
AGE	HDS		L7970
			71-86-04

STOCKHOLM DEN  
**VBB**  
BOX 9008  
107 41 STOCKHOLM S  
TEL. 08-22 84 80

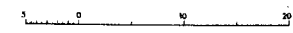

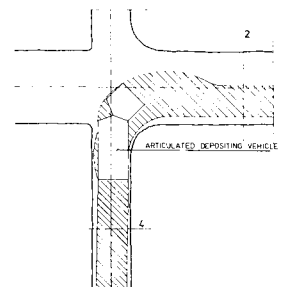
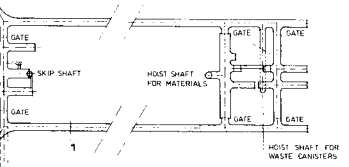
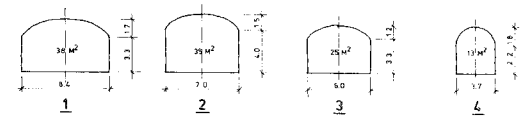
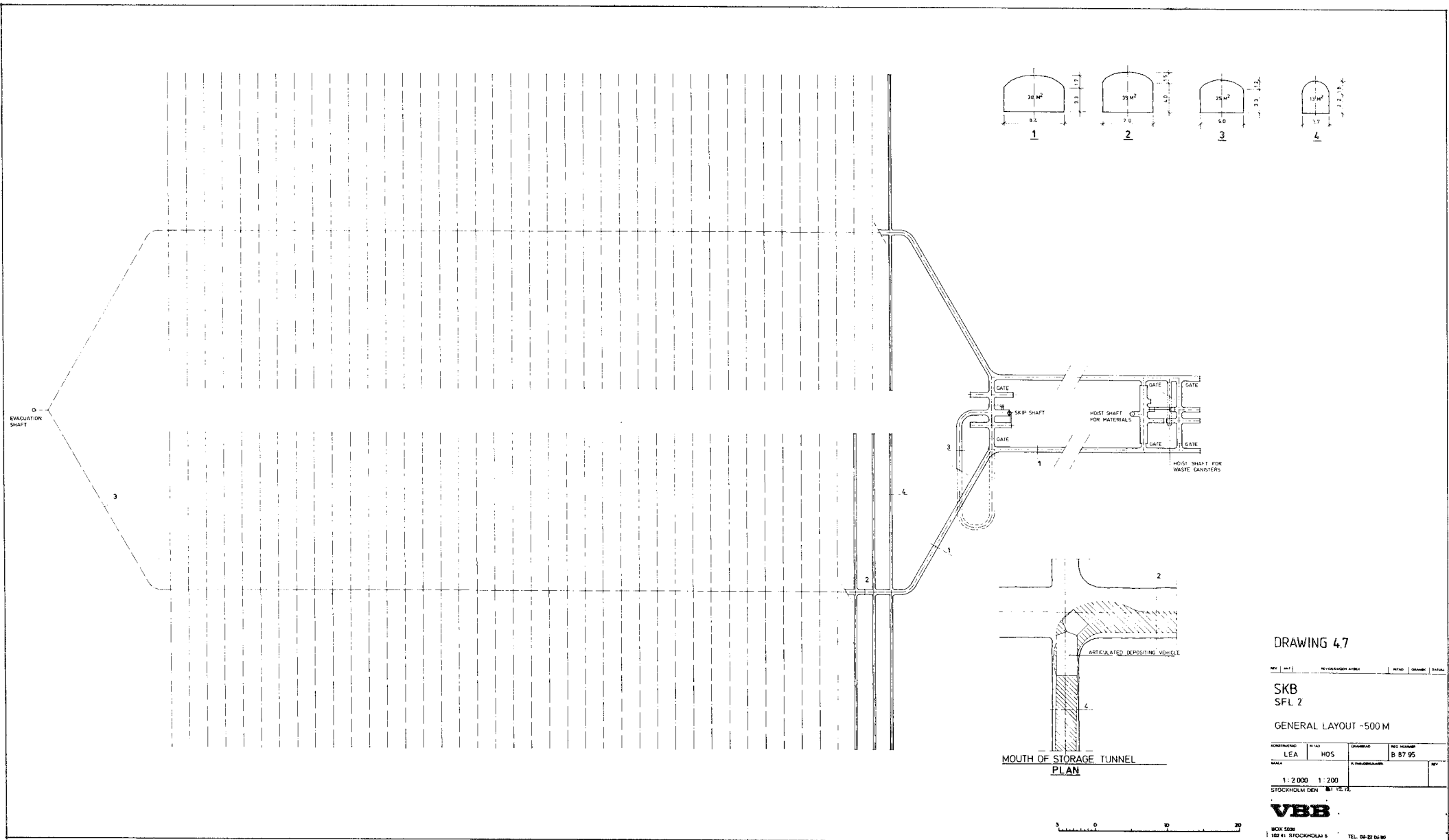

MOUTH OF STORAGE TUNNEL  
PLAN

DRAWING 4.7

REV. | DATE | REVISIONS | WHO | CHECKED | DATE

SKB  
SFL 2

GENERAL LAYOUT -500 M

APPROVED	BY	DATE	DESIGNED	REV. NUMBER
LEA	HOS			B 87 95
SCALE		1:2 000		1:200
STOCKHOLM DEN 11 15 74				

**VBB**  
BOX 5238  
102 41 STOCKHOLM S  
TEL. 08-22 04 80

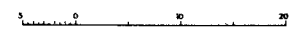

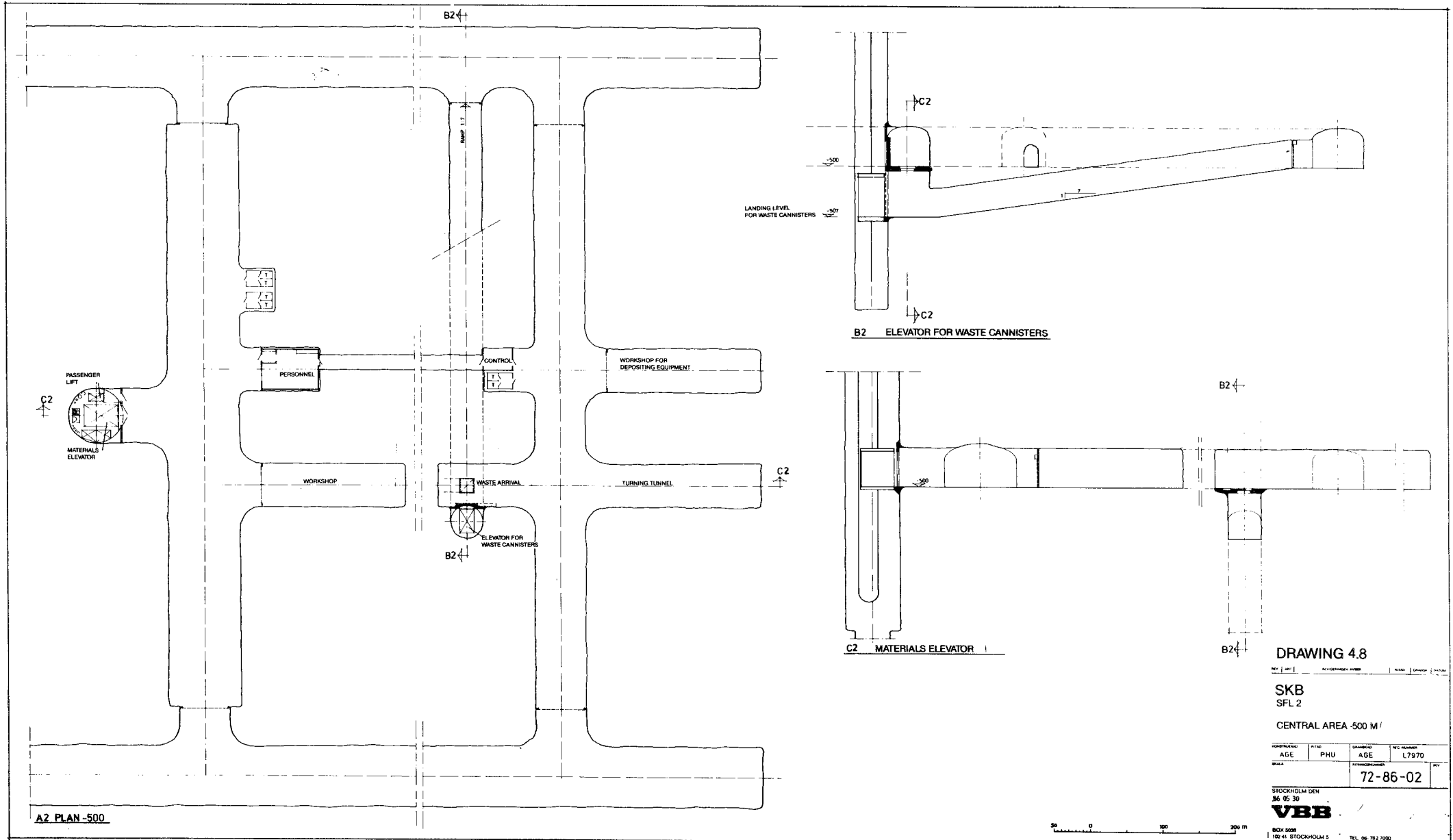

**DRAWING 4.8**

REV	DATE	BY	CHECKED	DATE	BY

SKB  
SFL 2

CENTRAL AREA -500 M/

CONTRACTOR	AGE	PHU	DESIGNER	AGE	REV. NUMBER
					L7970
SCALE					72-86-02
STOCKHOLM DEN 86 05 30					
<b>VBB</b>					
BOX 508 102 41 STOCKHOLM S TEL. 08 782 7000					

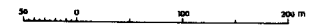

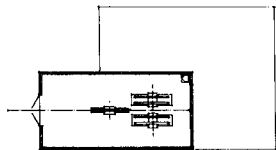

A3 PULLEY LEVEL

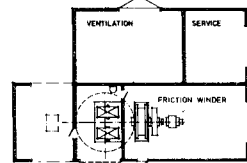

B3 GROUND LEVEL

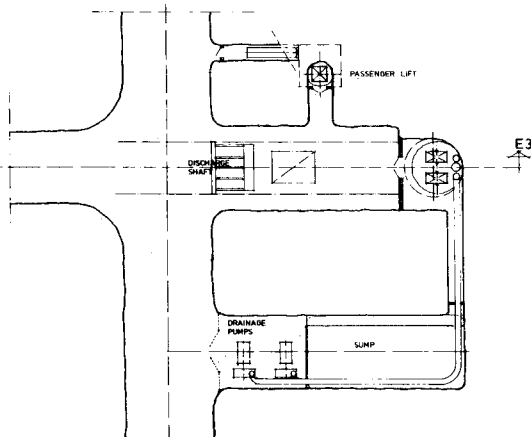

C3 ROCK DISCHARGE LEVEL -500.0

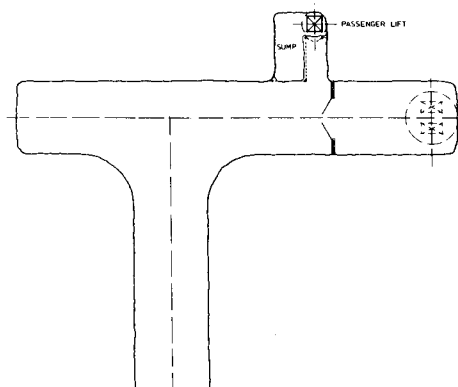

D3 SKIP SHAFT BOTTOM LEVEL -555.0

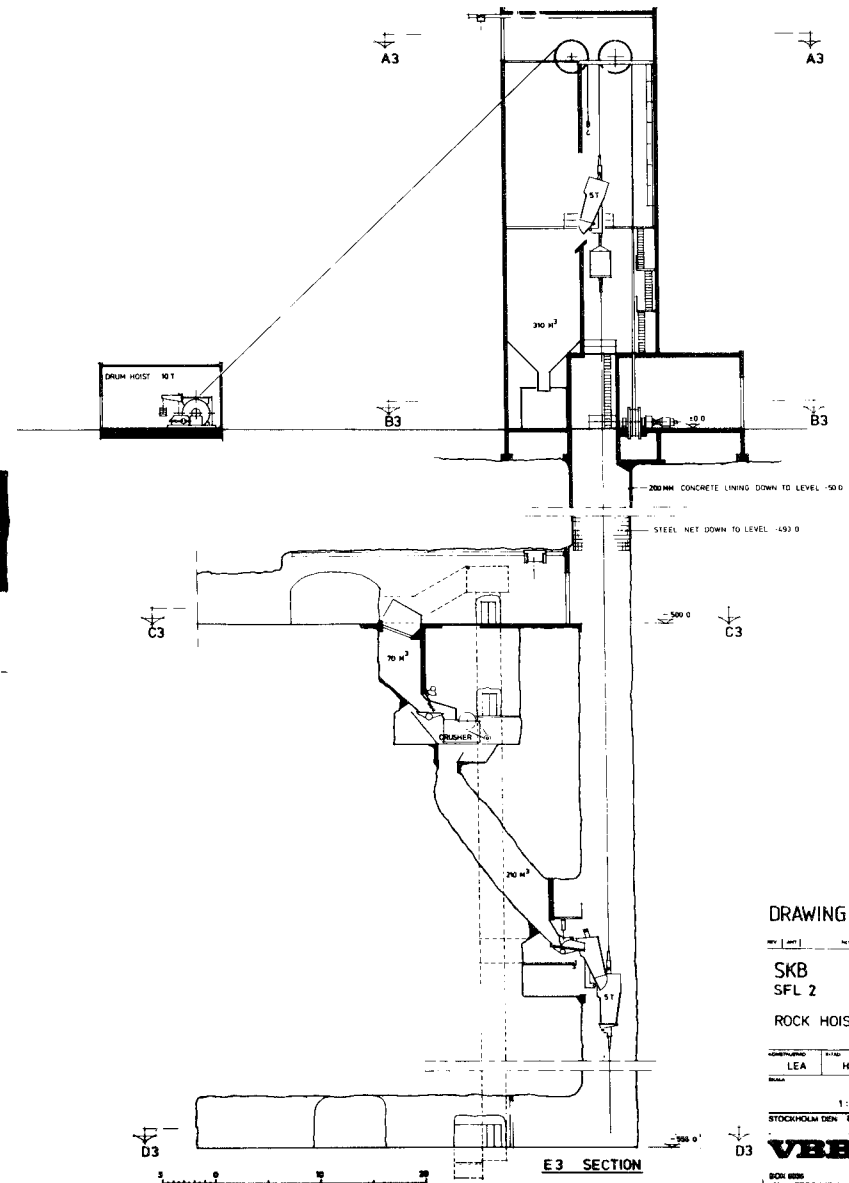

DRAWING 4.9

REV | AMT | NO. | VERIFICATION | DATE | DRAWN | CHECKED

SKB  
SFL 2

ROCK HOISTING

CONTRACT NO.	LEA	PROJ. NO.	HOS	DATE	REV. NO.
					B. 87.95

1:200  
STOCKHOLM DEN 8/12/92

**VBB**

BOX 8888  
162 41 STOCKHOLM S TEL. 08-22 88 89

SFL4 — DISPOSAL OF DECOMMISSIONING WASTE IN TUNNELS AFTER COMPLETION OF DISPOSAL IN SFL3 AND SFL5

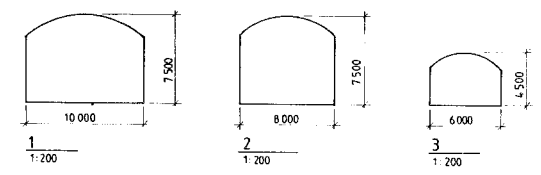
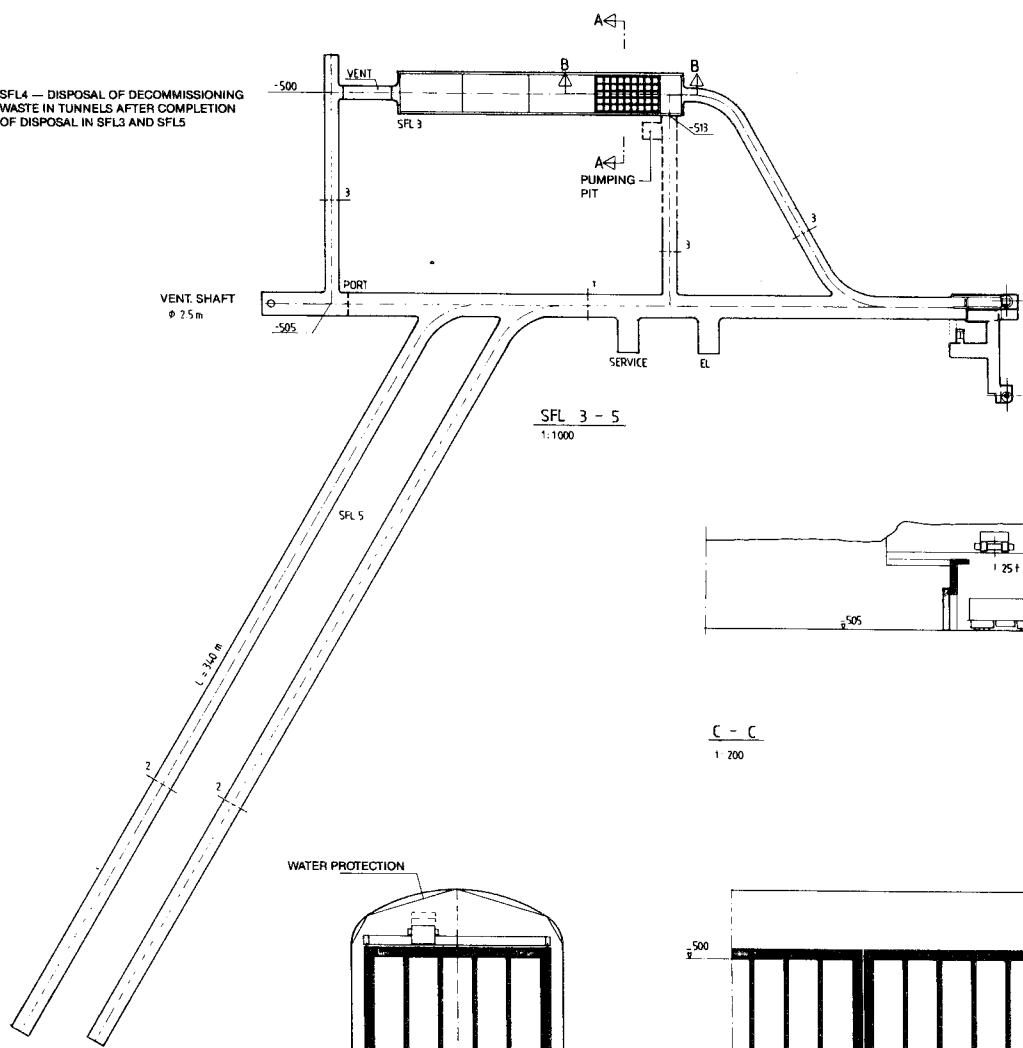

SFL 3 - 5  
1:1000

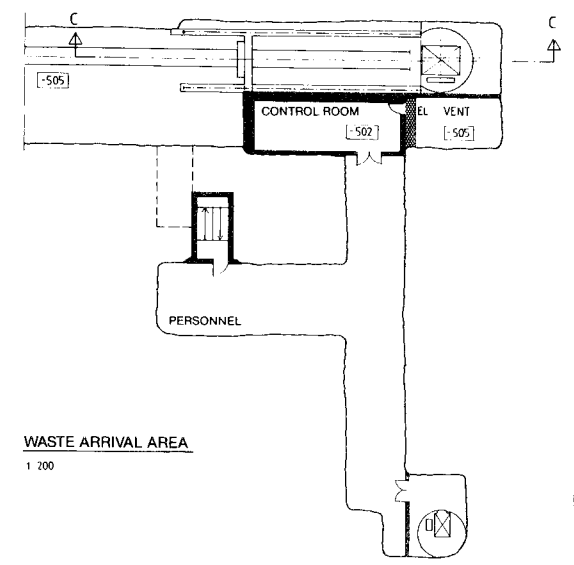
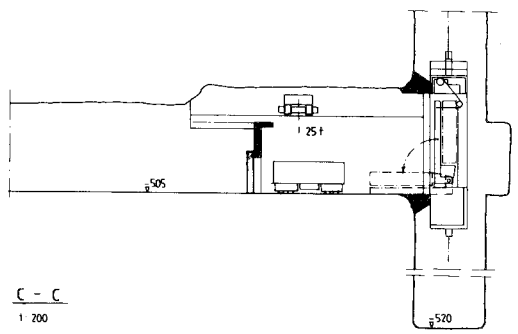

WASTE ARRIVAL AREA  
1:200

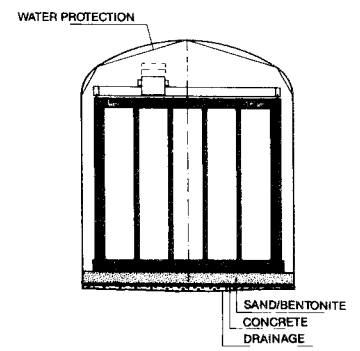

A - A  
1:200

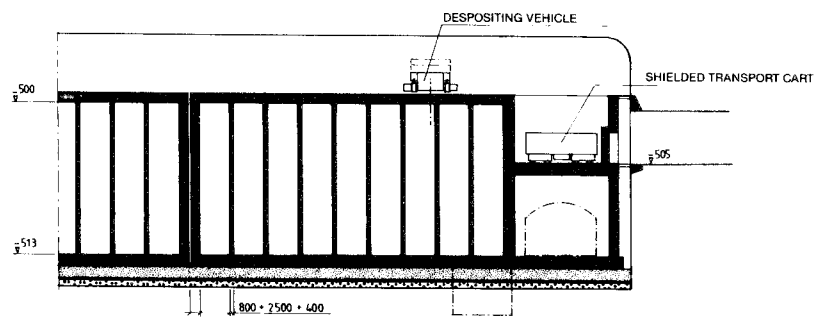

B - B  
1:200

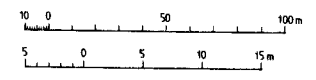

**DRAWING 4.10**

SKB  
SFL 3-5  
DISPOSAL VAULT -500

DESIGNED BY	AGE	SCALE	DATE
EGR	EGR	L 7970	

75-86-01

STOCKHOLM 1986-04-07

**VBB** *Ja: 9/1*

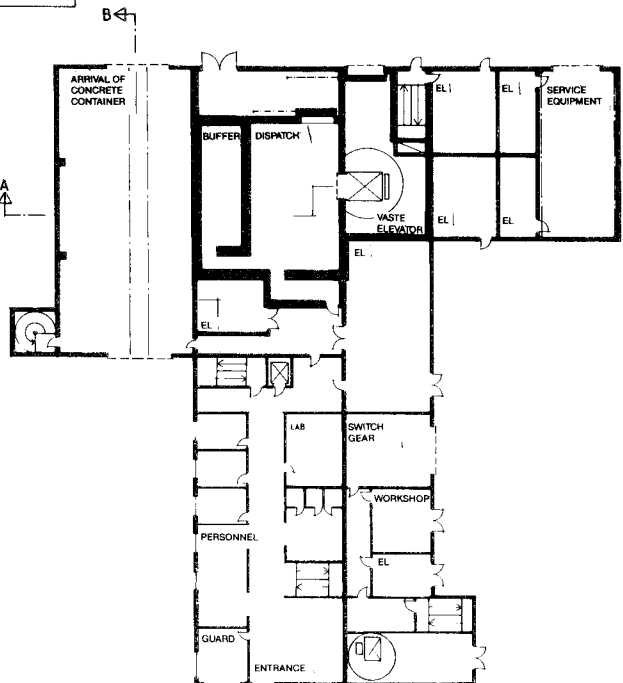

PLAN ±0.0

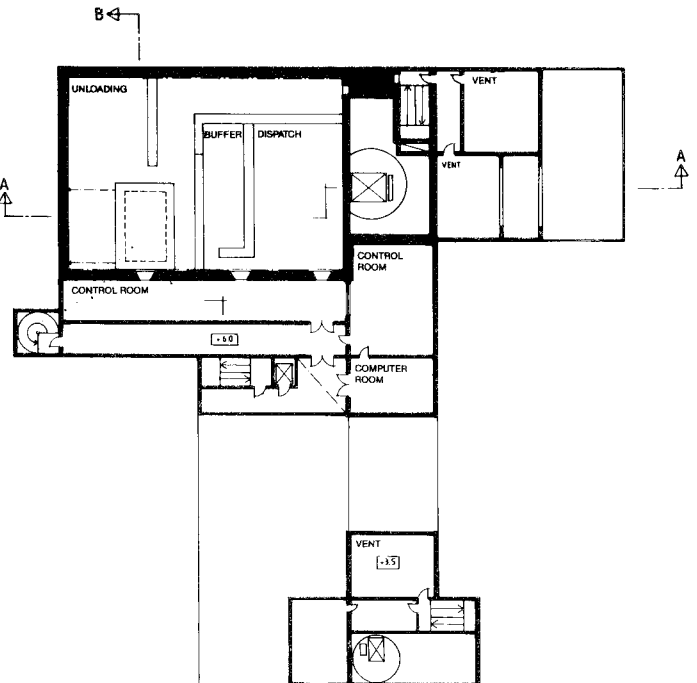

PLAN +6.0 AND +3.5

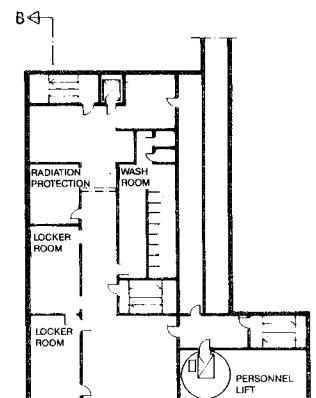

PLAN -3.5

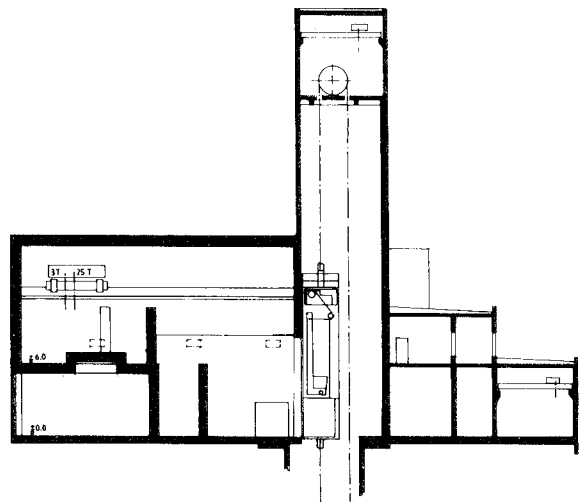

SECTION B

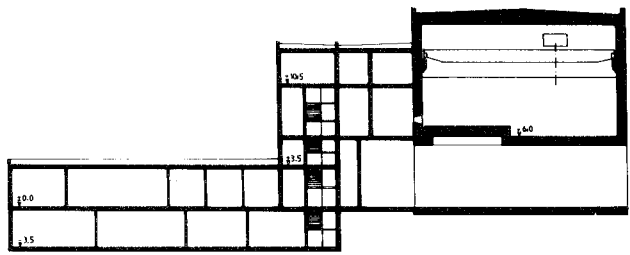

SECTION A

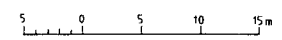

**DRAWING 4.11**

SKB

SFL 3-5  
RECEIVING BUILDING

KONTROLLERAD AGE	UTSÄD EGR	GRANSKAD PÅSKEDNINGEN	REVISERAD L 7970
75-86-02			BYG

STOCKHOLM 1986-04-08

**VBB**

*Sares f. my*



## APPENDIX 5

### FINAL REPOSITORY FOR REACTOR WASTE, SFR

#### FINAL REPOSITORY FOR REACTOR OPERATION WASTE, SFR 1

A final repository for short-lived low- and intermediate-level waste located at the Forsmark nuclear power station has been in operation since 1988. The waste derives primarily from reactor operation, but also from non-electricity-producing activities. In the latter case, the waste comes mainly from Studsvik. In all, SFR 1 will hold about 90 000 m<sup>3</sup> of waste, of which about 37 000 m<sup>3</sup> in silos.

The site plan of the repository is shown in Drawing 5.1. Two tunnels lead from the power station harbour out under the Baltic Sea to the rock cavern repository, which is built with a rock cover of at least 60 m. The water depth on the site is 5-6 m. The appearance of the repository when fully expanded is illustrated schematically in Figure A5.1.

SFR 1 is being built in two phases. The first phase, currently in operation, consists of one cylindrical rock cavern containing a concrete silo plus four 160-m-long rock vaults. The concrete silo contains intermediate-level waste. Three of the rock vaults contain low-level waste, handled by a radiation-shielded truck. The fourth rock vault contains intermediate-level waste and handling is remote-controlled. The second building phase comprises one additional silo and one to two rock vaults. The total volume of rock excavated for the two building phases will amount to about 600 000 m<sup>3</sup>.

The rock chamber for the silo is 70 m high and has a diameter of 30 m. A free-standing concrete silo is being built inside the rock cavern. The silo stands on a 1.5 m thick bed of compacted sand/bentonite. The space between the silo wall and the rock wall, about 1 m, is filled with bentonite granulate.

Internally, the concrete silo is divided into cells of square cross section, 2.6 x 2.6 m. This cellular division provides a stiffening of the silo wall and facilitates emplacement and grouting of the waste

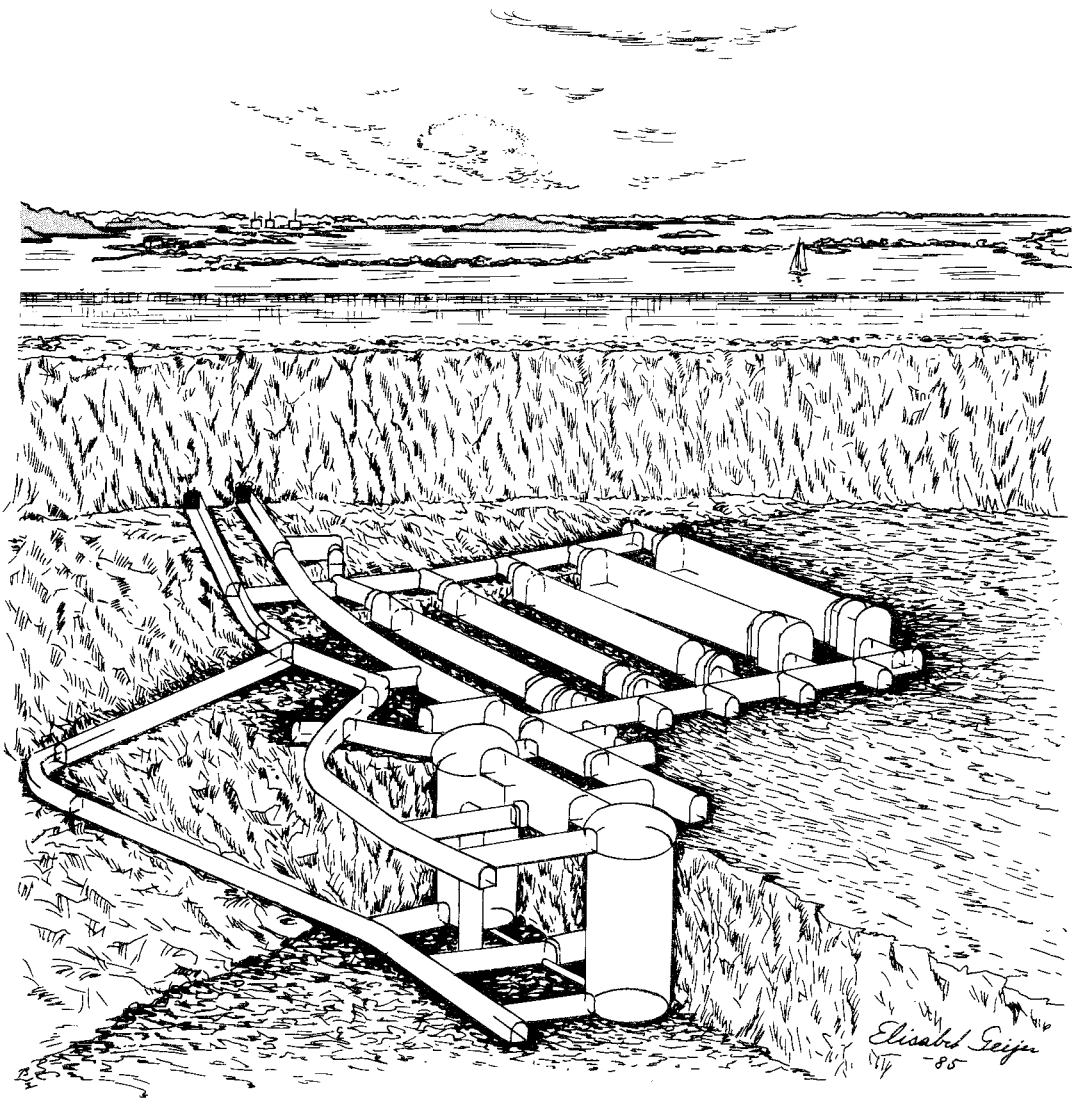

Figure A5.1 SFR 1.

packages. The procedure for depositing waste in the silo is schematically illustrated in Figure A5.2. The transport container with the waste packages is brought down into the repository by an electric-powered terminal vehicle and placed in a receiving room. Above the room runs a tunnel that is connected to the upper part of the silo and contains a railbound remote-controlled pole crane. The deposition vehicle picks up the waste packages, one at a time, out of the transport container, drives out onto the carousel crane over the silos, goes to the right position and lowers the package into one of the cells. When two layers of waste have been emplaced in the cell, they are grouted with a low-viscosity cement mortar. After comple

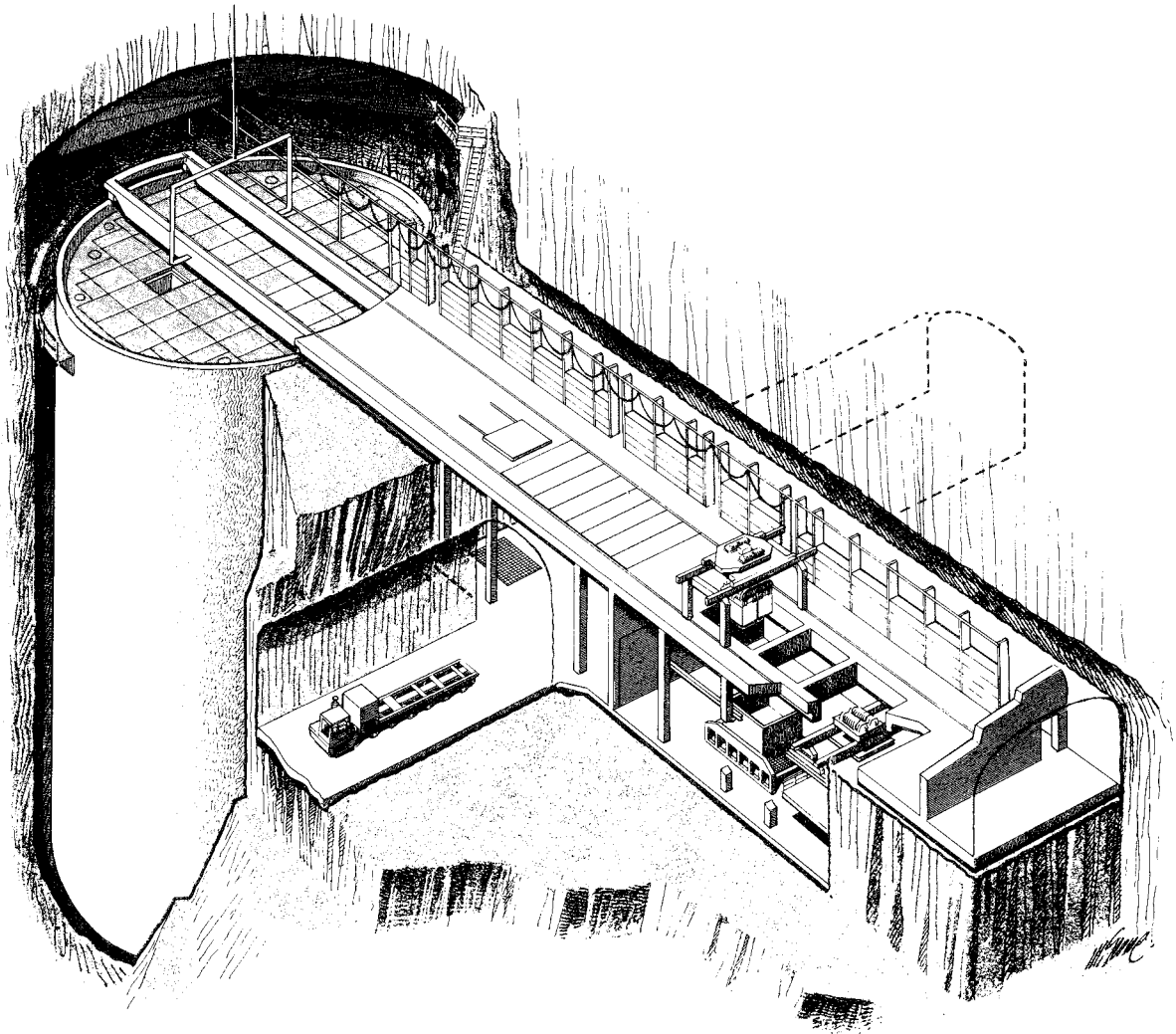

Figure A5.2 Deposition in silo, SFR 1.  
Schematic illustration.

tion of deposition, a concrete lid is poured over the silo and all remaining cavities are filled with sand/bentonite and backfill materials.

The intermediate-level waste emplaced in the rock vault is also grouted. While the low-level waste is not grouted.

The repository also includes surface facilities situated in the area around the tunnel mouths. See Drawing 5.2. The total building

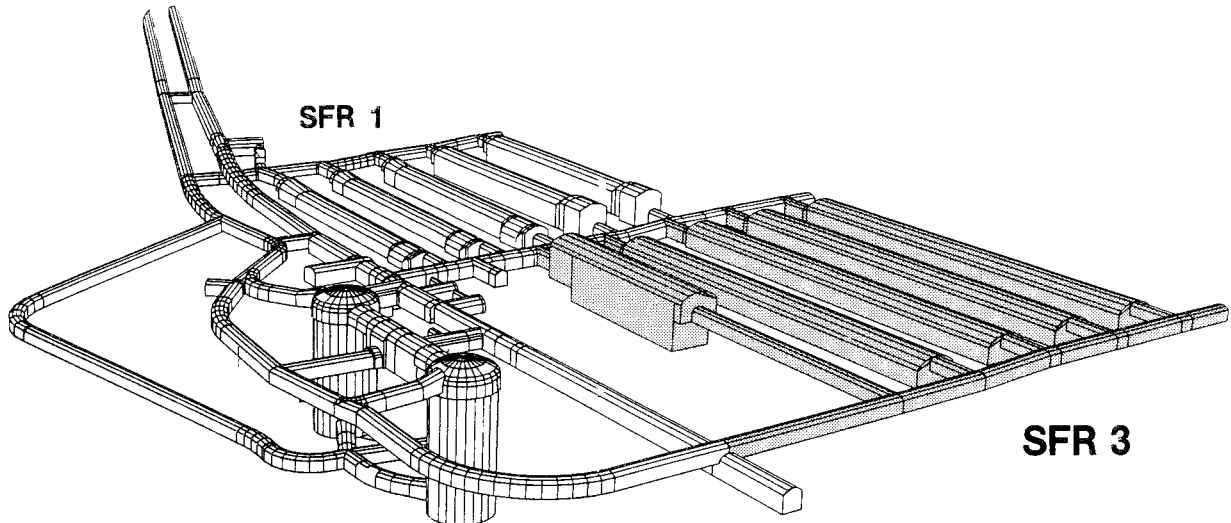

Figure A5.3 SFR 3.

volume is about 30 000 m<sup>3</sup>. The buildings include a ventilation building (for the rock chambers), office and workshop building and terminal building where the transport units are temporarily stored prior to transport down to the repository.

SFR 1 is scheduled to be sealed in the mid-2010s. The operating organization will amount to 20-25 men.

#### FINAL REPOSITORY FOR DECOMMISSIONING WASTE, SFR 3

SFR 3 is intended for decommissioning waste from the nuclear power plants and Studsvik. The total waste quantity may amount to about 100 000 m<sup>3</sup>. The site of SFR 3 has not yet been determined, but it is assumed at present that SFR 3 will constitute an expansion of SFR 1. SFR 3 will be in operation at the same time as the nuclear power plants are being decommissioned. Activities at SFR 1 will then have ceased and SFR 3 can be run by the same personnel force as SFR 1, and the operating and service buildings constructed for SFR 1 can also be utilized.

SFR 3 will consist of four rock vaults of a similar type as in SFR 1. See Figure A5.3. The decommissioning waste will primarily be transported to the repository packed in standard ISO containers that are deposited with their contents. ATB containers are used for waste that requires radiation shielding during transport and are emptied by means of a remote-controlled overhead crane.

LAYOUT C

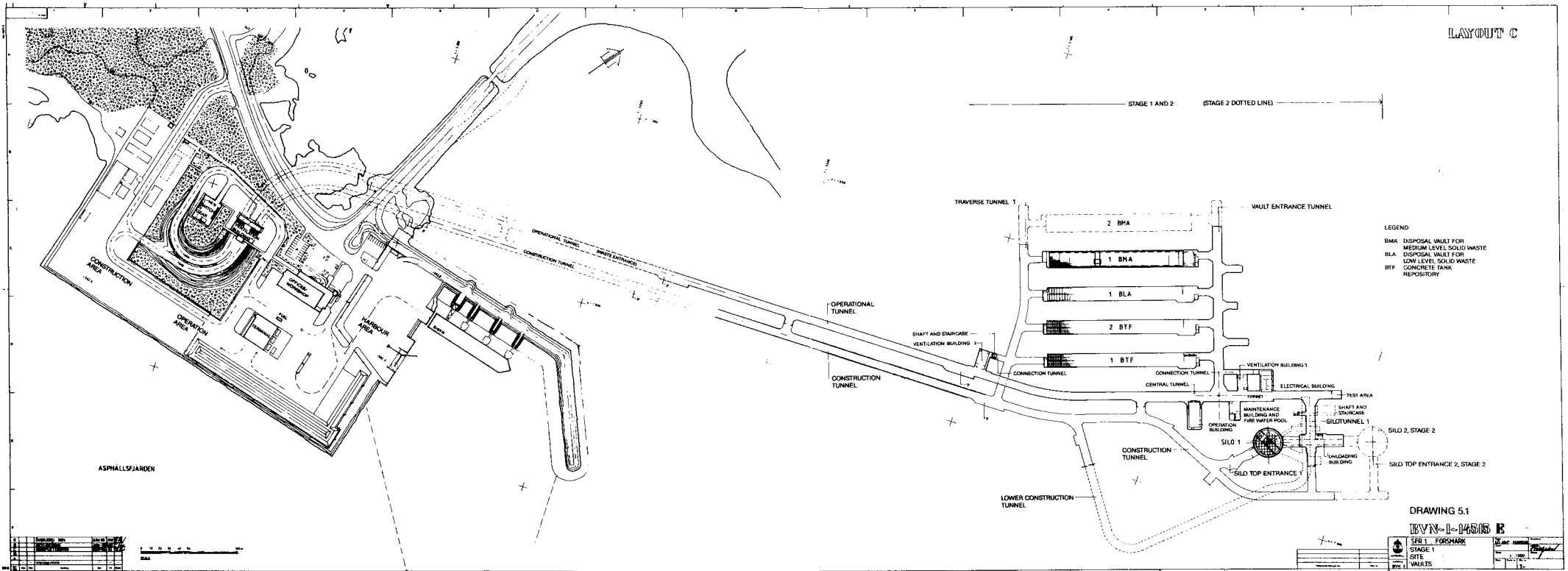

LAYOUT C

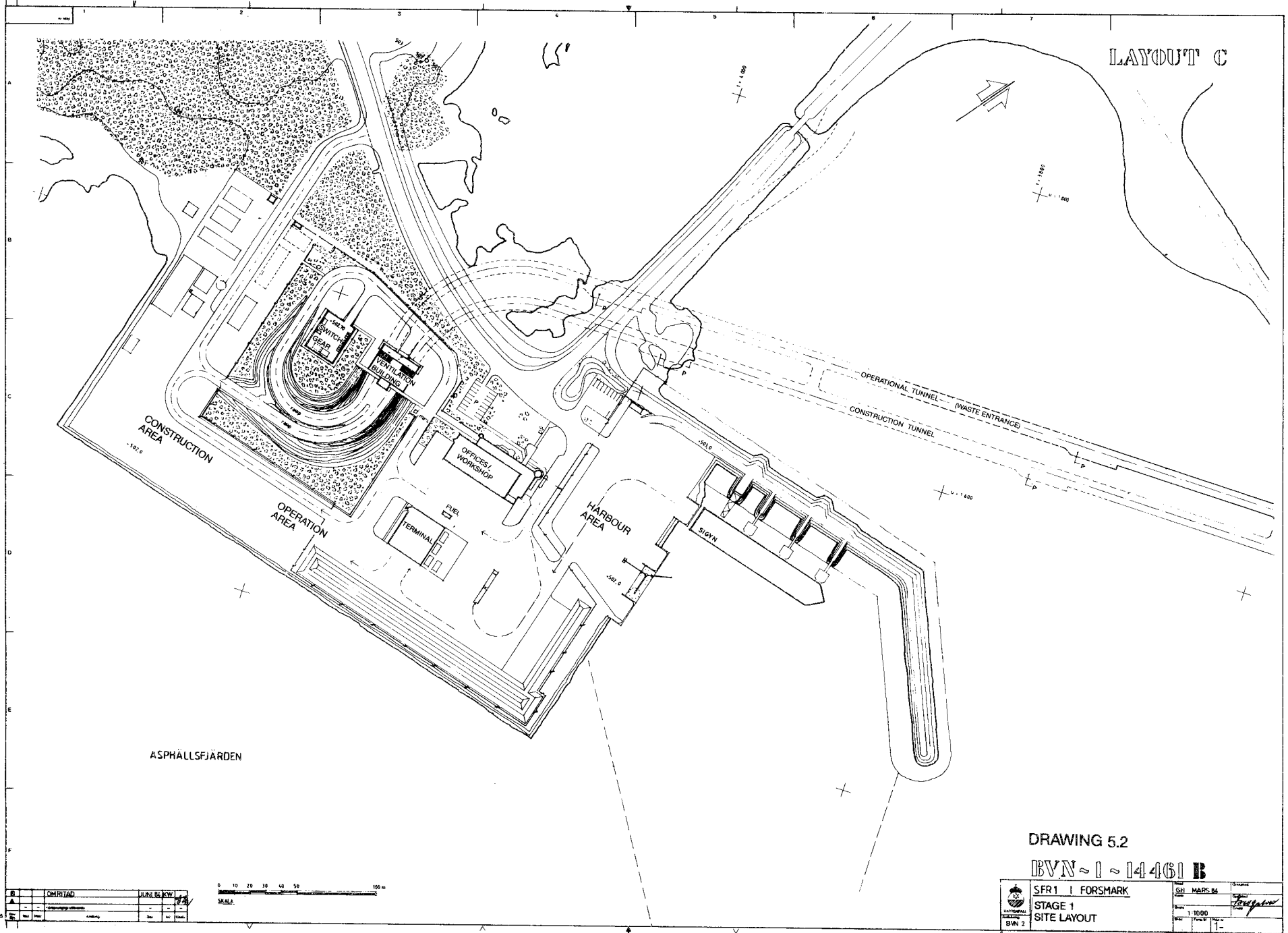

DRAWING 5.2

BNV ~ 1 ~ 14461 B

	SFR1   FORSMARK	GR: MARS 06	REVISION:
	STAGE 1		<i>Forssman</i>
	SITE LAYOUT	Scale: 1:3000	Sheet: 1-
BNV 2			

NO	OMPRITAD	JUNI 06	BNV
1			
2			
3			

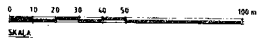

# LAYOUT C

STAGE 1 AND 2 (STAGE 2 DOTTED LINE)

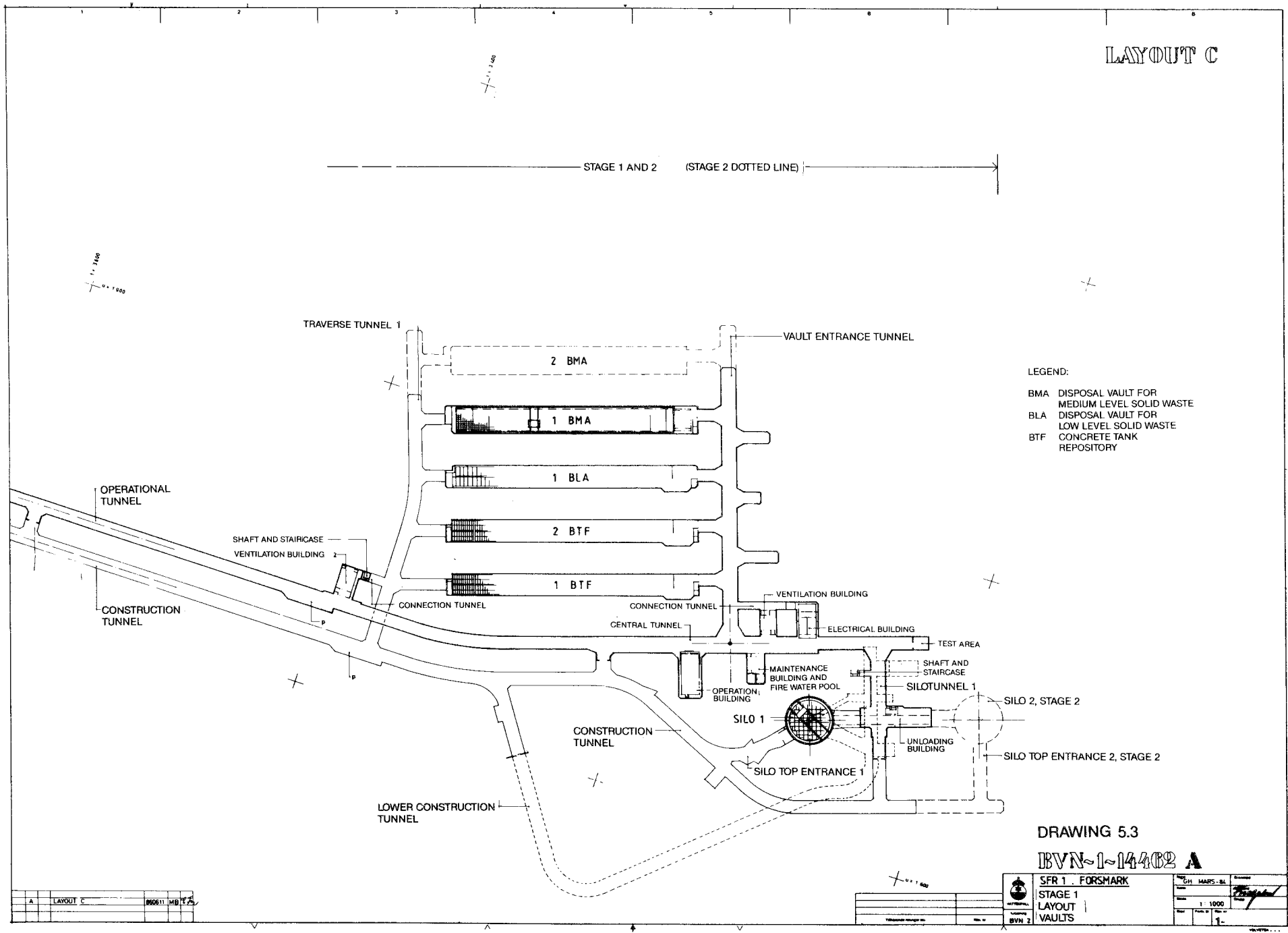

LEGEND:  
 BMA DISPOSAL VAULT FOR MEDIUM LEVEL SOLID WASTE  
 BLA DISPOSAL VAULT FOR LOW LEVEL SOLID WASTE  
 BTF CONCRETE TANK REPOSITORY

DRAWING 5.3

BNV-1-14402 A

A	LAYOUT C	00011 MB 1/1
---	----------	--------------

	SFR 1 FORSMARK	CH MARS-BL	Revision
	STAGE 1 LAYOUT 1 VAULTS	Scale 1:1000	
	Date: _____ Drawn by: _____ Checked by: _____ Approved by: _____	Date: _____ Drawn by: _____ Checked by: _____ Approved by: _____	Date: _____ Drawn by: _____ Checked by: _____ Approved by: _____

LEGEND:

- BMA DISPOSAL VAULT FOR MEDIUM LEVEL SOLID WASTE
- BLA DISPOSAL VAULT FOR LOW LEVEL SOLID WASTE

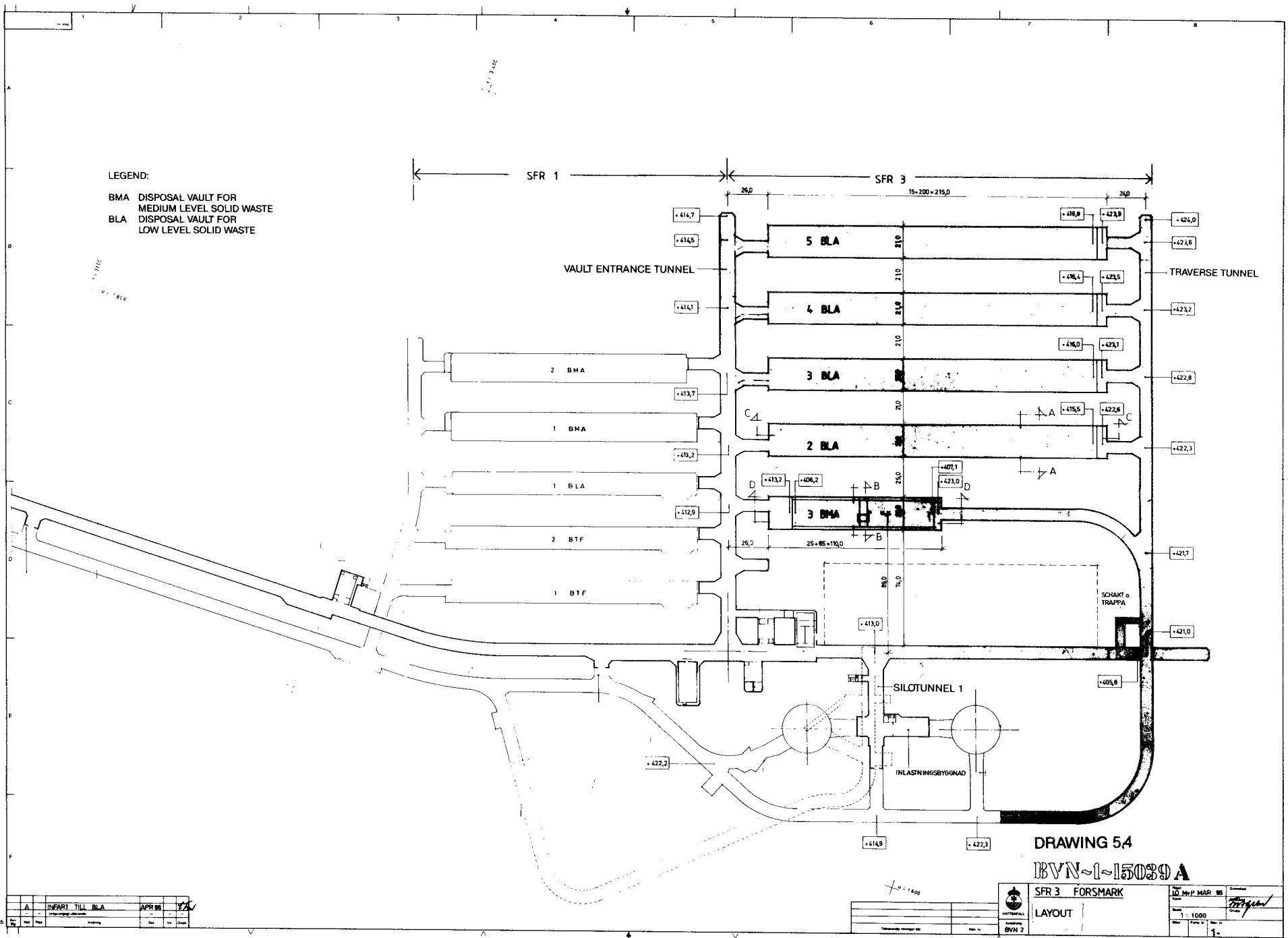

**DRAWING 54**  
**BYN-1-15039A**

A	INFART TILL BLA	APR 88	YJA
	Uppgrävsplan eller snitt		
	Ändring		

	SFR 3 FORSMARK	10 MAR 88
	LAYOUT	1:1000
BYN 2		



## APPENDIX 6

### DECOMMISSIONING OF THE NUCLEAR POWER PLANTS (Summary from Ref. 5)

When a nuclear power plant is retired from service, parts of it are radioactive and must be dismantled and disposed of in a safe manner. The procedures and costs involved in decommissioning nuclear power plants are described in the study.

The study shows that, from the viewpoint of radiological safety, a nuclear power plant can be dismantled immediately after it has been shut down and the fuel has been removed, which is estimated to take about one year. Most of the equipment that will be used in decommissioning is already available and is used routinely in maintenance and rebuilding work at the nuclear power plants. Special equipment need only be developed for dismantlement of the reactor vessel and for demolishing of heavy concrete structures. Examples of existing equipment that can be used for this after minor modifications are given in the study.

The dismantling of a nuclear power plant can be accomplished in about five years, with an average labour force of about 200 men. The maximum labour force required for Ringhals 1 has been estimated at about 500 men during the first years, when active systems are being dismantled on a number of fronts in the plant. During the last years when the buildings are being demolished, approximately 50 men are required.

In order to limit the labour requirement and the dose burden to the personnel, the material is taken out in as large pieces as possible. This means, for example, that pipes are cut into lengths of 2-5 m and packed directly in refuse containers, and that certain items of equipment are taken out and transported intact.

The study has focused on immediate dismantling. By waiting ten years or so, certain advantages can be gained due to the fact that the radioactivity in the plant declines. In the case of immediate dismantling, the same effect can be achieved by system decontamination. A number of other factors also influence the choice of time of dismantling, for example availability of personnel, need for the site and the availability of a final repository. Non-technical factors will

also be of importance. The choice of time of dismantling can therefore vary for different plants.

Cost figures below are taken from Technical Report 86-16 (ref. 5) and adjusted to the 1990 price level by using the price index.

The cost of decommissioning a boiling water reactor (BWR) of the size of Ringhals 1 has been estimated to be about MSEK 740 in January 1990 prices, and for a pressurized water reactor (PWR, Ringhals 2) about MSEK 630. The costs for the other Swedish nuclear power plants lie in the range of MSEK 560-1040. These are the direct costs for the decommissioning work, to which must be added the costs of transportation and disposal of the decommissioning waste, about 100 000 m<sup>3</sup>. These costs have been estimated to be about MSEK 800 for the 12 Swedish reactors.

Additional costs are incurred for the shutdown period from the time the nuclear power plant is finally taken out of operation until the dismantling work is begun. During this period, the fuel is transported away and some decontamination is carried out. The costs for the shutdown period are heavily dependent on the pace at which the plants are shut down and how long the shutdown period will last.

There are considerable quantities of spare parts, materials and equipment on the reactor sites that can be sold when the plants are closed down. The total value of these materials for all nuclear power plants is estimated to be MSEK 1200. To this must be added the value of the land and the infrastructure.

The table below presents the costs of immediate dismantling of the Swedish nuclear power plants.

Table S-1: Costs (MSEK) for decommissioning etc of the Swedish nuclear power plants.  
January 1990 price level

	Barsebäck 1-2	Ringhals 1-4	Oskarshamn 1-3	Forsmark 1-3
Shutdown operation <sup>1)</sup>	170	460	290	290
Decommissioning	1310	2640	2240	3000
Transport and final disposal of waste	120	250	200	230
Total	1600	3350	2730	3520
Residual value	-200	-400	-300	-300

<sup>1)</sup> An extra contingency of 10% has been added to these costs in the systems cost calculations.

# List of SKB reports

## Annual Reports

1977-78

TR 121

**KBS Technical Reports 1 – 120.**  
Summaries. Stockholm, May 1979.

1979

TR 79-28

**The KBS Annual Report 1979.**  
KBS Technical Reports 79-01 – 79-27.  
Summaries. Stockholm, March 1980.

1980

TR 80-26

**The KBS Annual Report 1980.**  
KBS Technical Reports 80-01 – 80-25.  
Summaries. Stockholm, March 1981.

1981

TR 81-17

**The KBS Annual Report 1981.**  
KBS Technical Reports 81-01 – 81-16.  
Summaries. Stockholm, April 1982.

1982

TR 82-28

**The KBS Annual Report 1982.**  
KBS Technical Reports 82-01 – 82-27.  
Summaries. Stockholm, July 1983.

1983

TR 83-77

**The KBS Annual Report 1983.**  
KBS Technical Reports 83-01 – 83-76  
Summaries. Stockholm, June 1984.

1984

TR 85-01

**Annual Research and Development Report 1984**

Including Summaries of Technical Reports Issued during 1984. (Technical Reports 84-01-84-19)  
Stockholm June 1985.

1985

TR 85-20

**Annual Research and Development Report 1985**

Including Summaries of Technical Reports Issued during 1985. (Technical Reports 85-01-85-19)  
Stockholm May 1986.

1986

TR 86-31

**SKB Annual Report 1986**

Including Summaries of Technical Reports Issued during 1986  
Stockholm, May 1987

1987

TR 87-33

**SKB Annual Report 1987**

Including Summaries of Technical Reports Issued during 1987  
Stockholm, May 1988

1988

TR 88-32

**SKB Annual Report 1988**

Including Summaries of Technical Reports Issued during 1988  
Stockholm, May 1989

## Technical Reports

### List of SKB Technical Reports 1990

TR 90-01

**FARF31 –**

**A far field radionuclide migration code for use with the PROPER package**

Sven Norman<sup>1</sup>, Nils Kjellbert<sup>2</sup>

<sup>1</sup> Starprog AB

<sup>2</sup> SKB AB

January 1990

TR 90-02

**Source terms, isolation and radiological consequences of carbon-14 waste in the Swedish SFR repository**

Rolf Hesböl, Ignasi Puigdomenech, Sverker Evans  
Studsvik Nuclear  
January 1990

TR 90-03

**Uncertainties in repository performance from spatial variability of hydraulic conductivities –**

**Statistical estimation and stochastic simulation using PROPER**

Lars Lovius<sup>1</sup>, Sven Norman<sup>1</sup>, Nils Kjellbert<sup>2</sup>

<sup>1</sup> Starprog AB

<sup>2</sup> SKB AB

February 1990

TR 90-04

**Examination of the surface deposit on an irradiated PWR fuel specimen subjected to corrosion in deionized water**

R. S. Forsyth, U-B. Eklund, O. Mattsson, D. Schrire  
Studsvik Nuclear  
March 1990

TR 90-05

**Potential effects of bacteria on radionuclide transport from a Swedish high level nuclear waste repository**

Karsten Pedersen  
University of Gothenburg, Department of General and Marine Microbiology, Gothenburg  
January 1990

TR 90-06

**Transport of actinides and Tc through a bentonite backfill containing small quantities of iron, copper or minerals in inert atmosphere**

Yngve Albinsson, Birgit Sätmark, Ingemar Engkvist, W. Johansson  
Department of Nuclear Chemistry, Chalmers University of Technology, Gothenburg  
April 1990

TR 90-07

**Examination of reaction products on the surface of UO<sub>2</sub> fuel exposed to reactor coolant water during power operation**

R S Forsyth, T J Jonsson, O Mattsson  
Studsvik Nuclear  
March 1990

TR 90-08

**Radiolytically induced oxidative dissolution of spent nuclear fuel**

Lars Werme<sup>1</sup>, Patrik Sellin<sup>1</sup>, Roy Forsyth<sup>2</sup>  
<sup>1</sup> Swedish Nuclear Fuel and waste Management Co (SKB)  
<sup>2</sup> Studsvik Nuclear  
May 1990

TR 90-09

**Individual radiation doses from unit releases of long lived radionuclides**

Ulla Bergström, Sture Nordlinder  
Studsvik Nuclear  
April 1990

TR 90-10

**Outline of regional geology, mineralogy and geochemistry, Poços de Caldas, Minas Gerais, Brazil**

H D Schorscher<sup>1</sup>, M E Shea<sup>2</sup>  
<sup>1</sup> University of Sao Paulo  
<sup>2</sup> Battelle, Chicago  
December 1990

TR 90-11

**Mineralogy, petrology and geochemistry of the Poços de Caldas analogue study sites, Minas Gerais, Brazil.**

**I: Osamu Utsumi uranium mine**  
N Waber<sup>1</sup>, H D Schorscher<sup>2</sup>, A B MacKenzie<sup>3</sup>, T Peters<sup>1</sup>  
<sup>1</sup> University of Bern  
<sup>2</sup> University of Sao Paulo  
<sup>3</sup> Scottish Universities Research & Reactor Centre (SURRC), Glasgow  
December 1990

TR 90-12

**Mineralogy, petrology and geochemistry of the Poços de Caldas analogue study sites, Minas Gerais, Brazil.**

**II: Morro do Ferro**  
N Waber  
University of Bern  
December 1990

TR 90-13

**Isotopic geochemical characterisation of selected nepheline syenites and phonolites from the Poços de Caldas alkaline complex, Minas Gerais, Brazil**

M E Shea  
Battelle, Chicago  
December 1990

TR 90-14

**Geomorphological and hydrogeological features of the Poços de Caldas caldera, and the Osamu Utsumi mine and Morro do Ferro analogue study sites, Brazil**

D C Holmes<sup>1</sup>, A E Pitty<sup>2</sup>, R Noy<sup>1</sup>  
<sup>1</sup> British Geological Survey, Keyworth  
<sup>2</sup> INTERRA/ECL, Leicestershire, UK  
December 1990

TR 90-15

**Chemical and isotopic composition of groundwaters and their seasonal variability at the Osamu Utsumi and Morro do Ferro analogue study sites, Poços de Caldas, Brazil**

D K Nordstrom<sup>1</sup>, J A T Smellie<sup>2</sup>, M Wolf<sup>3</sup>  
<sup>1</sup> US Geological Survey, Menlo Park  
<sup>2</sup> Conterra AB, Uppsala  
<sup>3</sup> Gesellschaft für Strahlen- und Umweltforschung (GSF), Munich  
December 1990

TR 90-16

**Natural radionuclide and stable element studies of rock samples from the Osamu Utsumi mine and Morro do Ferro analogue study sites, Poços de Caldas, Brazil**

A B MacKenzie<sup>1</sup>, P Linsalata<sup>2</sup>, N Miekeley<sup>3</sup>,  
J K Osmond<sup>4</sup>, D B Curtis<sup>5</sup>

<sup>1</sup> Scottish Universities Research & Reactor Centre (SURRC), Glasgow

<sup>2</sup> New York Medical Centre

<sup>3</sup> Catholic University of Rio de Janeiro (PUC)

<sup>4</sup> Florida State University

<sup>5</sup> Los Alamos National Laboratory

December 1990

TR 90-17

**Natural series nuclide and rare earth element geochemistry of waters from the Osamu Utsumi mine and Morro do Ferro analogue study sites, Poços de Caldas, Brazil**

N Miekeley<sup>1</sup>, O Coutinho de Jesus<sup>1</sup>,  
C-L Porto da Silveira<sup>1</sup>, P Linsalata<sup>2</sup>, J N Andrews<sup>3</sup>,  
J K Osmond<sup>4</sup>

<sup>1</sup> Catholic University of Rio de Janeiro (PUC)

<sup>2</sup> New York Medical Centre

<sup>3</sup> University of Bath

<sup>4</sup> Florida State University

December 1990

TR 90-18

**Chemical and physical characterisation of suspended particles and colloids in waters from the Osamu Utsumi mine and Morro do Ferro analogue study sites, Poços de Caldas, Brazil**

N Miekeley<sup>1</sup>, O Coutinho de Jesus<sup>1</sup>,  
C-L Porto da Silveira<sup>1</sup>, C Degueldre<sup>2</sup>

<sup>1</sup> Catholic University of Rio de Janeiro (PUC)

<sup>2</sup> PSI, Villingen, Switzerland

December 1990

TR 90-19

**Microbiological analysis at the Osamu Utsumi mine and Morro do Ferro analogue study sites, Poços de Caldas, Brazil**

J West<sup>1</sup>, A Viaita<sup>2</sup>, I G McKinley<sup>3</sup>

<sup>1</sup> British Geological Survey, Keyworth

<sup>2</sup> Uranio do Brasil, Poços de Caldas

<sup>3</sup> NAGRA, Baden, Switzerland

December 1990

TR 90-20

**Testing of geochemical models in the Poços de Caldas analogue study**

J Bruno<sup>1</sup>, J E Cross<sup>2</sup>, J Eikenberg<sup>3</sup>, I G McKinley<sup>4</sup>,  
D Read<sup>5</sup>, A Sandino<sup>1</sup>, P Sellin<sup>6</sup>

<sup>1</sup> Royal Institute of Technology (KTH), Stockholm

<sup>2</sup> AERE, Harwell, UK

<sup>3</sup> PSI, Villingen, Switzerland

<sup>4</sup> NAGRA, Baden, Switzerland

<sup>5</sup> Atkins ES, Epsom, UK

<sup>6</sup> Swedish Nuclear and Waste Management Co (SKB), Stockholm

December 1990

TR 90-21

**Testing models of redox front migration and geochemistry at the Osamu Utsumi mine and Morro do Ferro analogue sites, Poços de Caldas, Brazil**

J Cross<sup>1</sup>, A Haworth<sup>1</sup>, P C Lichtner<sup>2</sup>,  
A B MacKenzi<sup>3</sup>, L Moreno<sup>4</sup>, I Neretnieks<sup>4</sup>,  
D K Nordstrom<sup>5</sup>, D Read<sup>6</sup>, L Romero<sup>4</sup>,  
S M Sharland<sup>1</sup>, C J Tweed<sup>1</sup>

<sup>1</sup> AERE, Harwell, UK

<sup>2</sup> University of Bern

<sup>3</sup> Scottish Universities Research & Reactor Centre (SURRC), Glasgow

<sup>4</sup> Royal Institute of Technology (KTH), Stockholm

<sup>5</sup> US Geological Survey, Menlo Park

<sup>6</sup> Atkins ES, Epsom, UK

December 1990

TR 90-22

**Near-field high temperature transport: Evidence from the genesis of the Osamu Utsumi uranium mine analogue site, Poços de Caldas, Brazil**

L M Cathles<sup>1</sup>, M E Shea<sup>2</sup>

<sup>1</sup> University of Cornell, New York

<sup>2</sup> Battelle, Chicago

December 1990

TR 90-23

**Geochemical modelling of water-rock interactions at the Osamu Utsumi mine and Morro do Ferro analogue sites, Poços de Caldas, Brazil**

D K Nordstrom<sup>1</sup>, I Puigdomenech<sup>2</sup>, R H McNutt<sup>3</sup>

<sup>1</sup> US Geological Survey, Menlo Park

<sup>2</sup> Studsvik Nuclear, Sweden

<sup>3</sup> McMaster University, Ontario, Canada

December 1990

TR 90-24

**The Poços de Caldas Project: Summary and implications for radioactive waste management**

N A Chapman<sup>1</sup>, I G McKinley<sup>2</sup>, M E Shea<sup>3</sup>,  
J A T Smellie<sup>4</sup>

<sup>1</sup> INTERRA/ECL, Leicestershire, UK

<sup>2</sup> NAGRA, Baden, Switzerland

<sup>3</sup> Battelle, Chicago

<sup>4</sup> Conterra AB, Uppsala

TR 90-25

**Kinetics of UO<sub>2</sub>(s) dissolution reducing conditions: numerical modelling**

I Puigdomenech<sup>1</sup>, I Cass<sup>2</sup>, J Bruno<sup>3</sup>

<sup>1</sup> Studsvik AB, Nyköping, Sweden

<sup>2</sup> Department of Chemical Engineering, E.T. S. E. I. B. (U. P. C.), Barcelona, Spain

<sup>3</sup> Department of Inorganic Chemistry, The Royal Institute of Technology, Stockholm, Sweden

May 1990

TR 90-26

**The effect from the number of cells, pH and lanthanide concentration on the sorption of promethium on gramnegative bacterium (Shewanella Putrefaciens)**

Karsten Pedersen<sup>1</sup>, Yngve Albinsson<sup>2</sup>

<sup>1</sup> University of Göteborg, Department of General and Marine Microbiology, Gothenburg, Sweden

<sup>2</sup> Chalmers University of Technology, Department of Nuclear Chemistry, Gothenburg, Sweden

June 1990

TR 90-27

**Isolation and characterization of humics from natural waters**

B Allard<sup>1</sup>, I Arsenie<sup>1</sup>, H Borén<sup>1</sup>, J Ephraim<sup>1</sup>,  
G Gårdhammar<sup>2</sup>, C Pettersson<sup>1</sup>

<sup>1</sup> Department of Water and Environmental Studies, Linköping University, Linköping, Sweden

<sup>2</sup> Department of Chemistry, Linköping University, Linköping, Sweden

May 1990

TR 90-28

**Complex forming properties of natural organic acids. Part 2. Complexes with iron and calcium**

James H Ephraim<sup>1</sup>, Andrew S Mathuthu<sup>2</sup>,  
Jacob A Marinsky<sup>3</sup>

<sup>1</sup> Department of Water in Environment and Society, Linköping University, Linköping, Sweden

<sup>2</sup> Chemistry department, University of Zimbabwe, Harare, Zimbabwe

<sup>3</sup> Chemistry Department, State University of New York at Buffalo, Buffalo, NY, USA

July 1990

TR 90-29

**Characterization of humic substances from deep groundwaters in granitic bedrock in Sweden**

C Pettersson, J Ephraim, B Allard, H Borén  
Department of Water and Environmental Studies,  
Linköping University, Linköping, Sweden

June 1990

TR 90-30

**The earthquakes of the Baltic shield**

Ragnar Slunga  
Swedish National Defence Research Institute  
June 1990

TR 90-31

**Near-field performance of the advanced cold process canister**

Lars Werme  
Swedish Nuclear Fuel and Waste Management Co (SKB)  
September 1990

TR 90-32

**Radioclide transport paths in the nearfield – a KBS-3 concept study**

Roland Pusch  
Clay Technology AB and Lund University of Technology  
July 1990