

SKB

**TECHNICAL
REPORT**

88-32

SKB ANNUAL REPORT 1988

**Including Summaries of Technical Reports
Issued during 1988**

Stockholm, December 1989

SVENSK KÄRNBRÄNSLEHANTERING AB

SWEDISH NUCLEAR FUEL AND WASTE MANAGEMENT CO

BOX 5864 S-102 48 STOCKHOLM

TEL 08-665 28 00 TELEX 13108-SKB

SKB ANNUAL REPORT 1988

**Including Summaries of Technical Reports
Issued during 1988**

Stockholm, December 1989

FOREWORD

The Annual Report on SKB's activities during 1988 covers planning, building and operational activities as well as research and development work.

During 1987 the construction work of the central repository for final disposal of low and medium level waste – SFR – was completed and SFR started its operations in the spring of 1988.

With SFR and the central interim storage facility for spent fuel – CLAB – in operation SKB has an operating and well integrated system for handling of all radioactive residues within the country for a long time ahead.

For the remaining facilities – the final repository for spent nuclear fuel – comprehensive research is well under way, aiming at investigating alternative disposal concepts as well as optimizing proposed systems. The scientific and political acceptance of the KBS-3 concept with regard to safety and radiation protection, the existing operating systems and the governmental approval of the longterm SKB R&D programme constitute a firm basis for the future activities of SKB.

International co-operation and exchange of information in all fields of the back-end of the nuclear fuel cycle is important and of great value for SKB's work. We hope this Annual Report will be of interest and that it will enhance the international information exchange.

Stockholm in December 1989

**SWEDISH NUCLEAR FUEL AND WASTE
MANAGEMENT CO – SKB**



Sten Bjurström
President

ABSTRACT

This is the annual report on the activities of the Swedish Nuclear Fuel and Waste Management Co, SKB. It contains in part I an overview of SKB activities in different fields. Part II gives a description of the research and development work on nuclear waste disposal performed during 1988.

Lectures and publications during 1988 as well as reports issued in the SKB technical report series are listed in part III.

Part IV contains the summaries of all technical reports issued during 1988.

SKB is the owner of CLAB, the Central Facility for Interim Storage of Spent Nuclear Fuel, located at Oskarshamn. CLAB was taken into operation in July 1985 and to the end of 1988 in total 860 tonnes of spent fuel (measured as uranium) has been received. Transportation from the nuclear sites to CLAB is made by a special ship, M/S SIGYN.

At Forsmark the construction of the final repository for Radioactive Waste – SFR – is completed and the facility was taken in operation in April 1988. The repository is situated in crystalline rock under the Baltic Sea. The first construction phase includes rock caverns for 60 000 m³ of waste. A second phase for additional 30 000 m³ is planned to be built and commissioned around the year 2000.

SKB is in charge of a comprehensive research and development program on geological disposal of nuclear waste. The total cost for R&D during 1988 was 123.4 MSEK of which 19.3 MSEK came from participants outside Sweden.

Some of the main areas for SKB research are:

- Groundwater movements.
- Bedrock stability.
- Groundwater chemistry and nuclide migration.
- Methods and instruments for in situ characterization of crystalline bedrock.
- Characterization and leaching of spent nuclear fuel.
- Properties of bentonite for buffer, backfilling and sealing.
- Natural ageing of recipients in the biosphere.
- Model development and safety assessment.
- Preparations for a new underground research laboratory.

Geological site-investigations are a substantial part of the program. SKB is also the managing participant of the international Stripa-project under OECD/NEA.

Cost calculations for the total nuclear waste management system, including decommissioning of all reactors, are updated annually. The total cost is estimated to SEK 47 billion which is less than 10% of the value of the electricity being produced.

SKB also handles matters pertaining to prospecting and enrichment as well as stockpiling of uranium as strategic reserves for the Swedish nuclear power industry.

Consulting services from SKB and associated expert groups are available on a commercial basis. They are coordinated and marketed through SwedPower, which has the same main owners as SKB.

CONTENTS

	Page
PART I OVERVIEW OF SKB ACTIVITIES	9
1 General Background	
2 Nuclear Fuel Supply	
3 Interim Storage of Spent Fuel, CLAB	
4 Transportation System	
5 Final Repository for Radioactive Waste, SFR	
6 Research and Development 1988	
7 System Planning and Cost Calculations	
8 Consulting Services	
9 Public Affairs and Media Relations	
References Part I	
PART II RESEARCH AND DEVELOPMENT DURING 1987	39
10 Repository Design	
11 Waste Forms	
12 Canister Materials	
13 Buffer and Backfill	
14 Geoscience	
15 Biosphere	
16 Chemistry	
17 Safety Assessment	
18 Stripa Project	
19 Natural Analogue Studies	
20 Documentation	
References Part II	
PART III APPENDICES	107
Appendix 1 Organization Charts for SKB and its Divisions	
2 Lectures and Publications 1988	
3 List of SKB Annual Reports 1977-1987	
4 List of SKB Technical Reports 1988	
5 Authors of SKB Technical Reports 1988 in Alphabetical Order	
PART IV SUMMARIES OF TECHNICAL REPORTS ISSUED DURING 1988	125

SKB ANNUAL REPORT 1988

Part I

Overview of SKB Activities

CONTENTS OF PART I

	Page	
1	GENERAL BACKGROUND	13
1.1	The Swedish Nuclear Power Program	13
1.2	Legal and Organizational Framework	13
1.3	The Swedish Nuclear Waste Management System	14
2	NUCLEAR FUEL SUPPLY	17
2.1	Natural Uranium	17
2.2	Conversion	17
2.3	Enrichment	17
2.4	Fabrication of Fuel Assemblies	18
2.5	Nuclear Fuel Stockpile	18
2.6	Costs	18
3	INTERIM STORAGE OF SPENT FUEL, CLAB	19
3.1	General	19
3.2	Operating Experiences	19
4	TRANSPORTATION SYSTEM	21
4.1	General	21
4.2	Operating Experiences	21
5	FINAL REPOSITORY FOR RADIOACTIVE WASTE, SFR	23
5.1	General	23
5.2	Design and Construction	23
5.3	Operation Permit	24
5.4	Waste Acceptance	25
5.5	Operation	26
6	RESEARCH AND DEVELOPMENT 1988	27
6.1	General	27
6.2	Summary of R&D-activities during 1988	27
6.2.1	Engineered Barriers and Repository Design	27
6.2.2	Geoscience	28
6.2.3	Biosphere	29
6.2.4	Chemistry	29
6.2.5	Safety Assessment	29
6.3	International Cooperation	29
6.3.1	Stripa Project	29
6.3.2	Poços de Caldas Project	30
6.3.3	JSS-project	30
6.3.4	Other International Activities	30

	Page	
7	SYSTEM PLANNING AND COST CALCULATIONS	31
7.1	System Planning Activities	31
7.2	Reprocessing	31
7.3	Cost Calculations and Back-End Fee	31
7.4	Decommissioning of Nuclear Power Plants	32
8	CONSULTING SERVICES	33
9	PUBLIC AFFAIRS AND MEDIA RELATIONS	35
9.1	General	35
9.2	SKB Information Activities	35
9.3	Printed Material	35
9.4	Video Cassettes and Films	35
	REFERENCES PART I	37

1 GENERAL BACKGROUND

1.1 THE SWEDISH NUCLEAR POWER PROGRAM

Sweden's nuclear power program consists of 12 nuclear reactors located at four different sites and with a combined capacity of 9 900 MW net electric power. Main data and location of the 12 units are shown in Figure 1-1. The nuclear power plants generated 45% of the total Swedish electric power produced in 1988.

Swedish reactors

Reactor		Power MW _e	Commercial operation	Energy availability in 1988 %
Oskarshamn 1	BWR	440	1972	75
Oskarshamn 2	BWR	600	1974	88
Oskarshamn 3	BWR	1160	1985	84
Barsebäck 1	BWR	600	1975	95
Barsebäck 2	BWR	600	1977	89
Ringhals 1	BWR	790	1976	77
Ringhals 2	PWR	800	1975	66
Ringhals 3	PWR	920	1981	82
Ringhals 4	PWR	920	1983	90
Forsmark 1	BWR	970	1980	87
Forsmark 2	BWR	970	1981	90
Forsmark 3	BWR	1140	1985	88

1.2 LEGAL AND ORGANIZATIONAL FRAMEWORK

The nuclear power plants are owned by the following four companies:

- Statens Vattenfallsverk (Swedish State Power Board; Vattenfall) is the largest electricity producer in Sweden and owns the Ringhals plant.
- Sydsvenska Värmekraft AB (subsidiary of Sydkraft AB) is the owner of the Barsebäck plant.
- OKG AB is the owner of the Oskarshamn plant. Sydkraft is the major shareholder of OKG.
- Forsmark Kraftgrupp AB (FKA) is the owner of the Forsmark plant. Vattenfall has 74.5% of the shares in FKA.

The Swedish Nuclear Fuel and Waste Management Company, SKB (SKB = Svensk Kärnbränslehantering AB) has been formed by these four power utilities. SKB shall develop, plan, construct and operate facilities and systems for the management and disposal of spent nuclear fuel and radioactive wastes from the Swedish nuclear power plants. On the behalf of its owners SKB is responsible for all handling, transport and storage of the nuclear wastes outside of the nuclear power production facilities.

SKB is also in charge of the comprehensive research program in the waste field which the utilities are responsible for according to the law. Finally SKB handles matters pertaining to enrichment and reprocessing services as well as stockpiling of uranium for the Swedish nuclear power industry and provides assistance at the request of its owners in uranium procurement.

The total central staff of SKB is about 50 persons. The organization is presented in Appendix 1. For the bulk of the work a large number of organizations and individuals outside SKB are contracted. As a whole about 500 persons are involved in SKB waste handling work.

SKB is the organization that has the lead operative role in the Swedish waste management program both with respect to planning, construction and operation of facilities and systems and with respect to research and development. The role has its roots in the legislation briefly described below. Figure 1-2 gives an overview of the most important laws and the corresponding authorities involved.

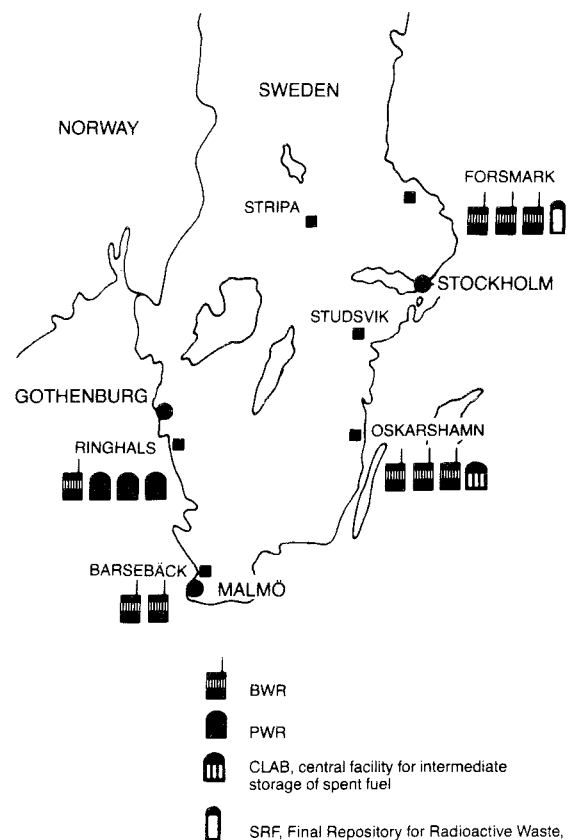

Figure 1-1. The Swedish nuclear power programme.

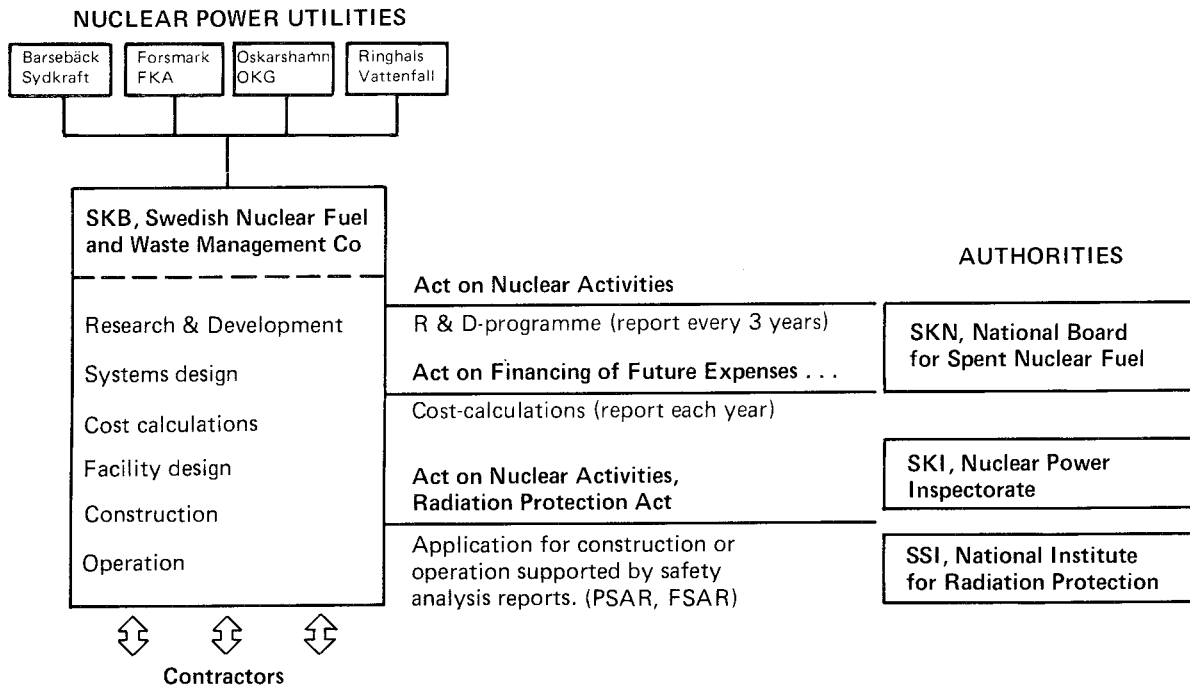

Figure 1-2. Legal framework for activities of SKB.

There are three important laws which regulate the nuclear activities:

- The Act on Nuclear Activities.
- The Act on the Financing of Future Expenses for Spent Nuclear Fuel etc.
- The Radiation Protection Act.

The Act on Nuclear Activities /1-1/ puts the primary responsibility for the safety on the owner of a nuclear installation. The owner is thus responsible for safety during design, construction and operation of nuclear facilities, for the handling and final disposal of nuclear wastes and for the dismantling and decommissioning of the facility. The responsibility also includes the necessary research and development in the waste management field. According to the act a research programme must be submitted to the authorities every three years and the first programme was submitted in September 1986.

The authorities for supervision of the safety provisions in the Act on Nuclear Activities are the Swedish Nuclear Power Inspectorate (SKI), and the National Board for Spent Nuclear Fuel (SKN). The National Institute for Radiation Protection (SSI) is supervising provisions of the Radiation Protection Act. The research program is supervised by the National Board for Spent Nuclear Fuel (SKN).

The latter authority is also supervising the adherence to the Act on Financing of Future Expenses for Spent Fuel. According to this law the waste management activities including future decommissioning of all reactors are financed from a fund built up from fees on the nuclear power production.

The fees are revised annually by SKN, which proposes the fees for the next year to the government. The average fee on nuclear electricity since 1984 has been 0.019 SEK per kWh.

The radiation protection act contains basic rules for protection against ionizing radiation for

- those who work at nuclear installations and other facilities with potential radiation hazards,
- the general public who lives or stays outside such installations or facilities.

The competent authority in these matters is the Swedish National Institute for Radiation Protection (SSI).

The three competent authorities have separate funds for the research needed to fulfil their obligations. SKN is also supporting additional waste management research to the SKB-program. In order to enable a coordination of the research programs carried out by the authorities a special “Consultative Committee for Nuclear Waste Management” (KASAM) was founded in 1985. The committee shall report to the government bi-annually on the state of the knowledge in the nuclear waste field /1-2/.

1.3 THE SWEDISH NUCLEAR WASTE MANAGEMENT SYSTEM

A complete system has been planned for the management of all radioactive residues from the 12 nuclear

Table 1-1. Waste categories.

WASTE CATEGORY	ORIGIN	WASTE FORM	PROPERTIES	QUANTITY
1 Spent fuel	Operation of nuclear reactors	Fuel rods encapsulated in canisters	High heat flux and radiation at first. Contains long-lived nuclides	5 600 canisters (7 800 tu)
2 Transuranic-bearing waste	Waste from the Studsvik research facility	Solidified in concrete	Low- to medium-level. Contains long-lived nuclides	6 000 m ³
3 Core components and internals	Scrap metal from inside reactor vessels	Untreated or cast in concrete	Low- to medium-level. Contains certain long-lived nuclides	19 700 m ³
4 Reactor waste	Operating waste from nuclear power plants etc.	Solidified in concrete or bitumen. Compacted waste	Low- to medium-level. Shortlived	95 000 m ³
5 Decommissioning waste	From dismantling of nuclear facilities	Untreated for the most part	Low- to medium-level. Shortlived	114 000 m ³

reactors and from research facilities. The system is based on the projected generation of waste up to the year 2010.

Residues generated by the operation of the reactors are spent nuclear fuel and different kinds of low- and medium level wastes. Furthermore, in the future decommissioning waste will be generated when the reactors are dismantled.

The types and total quantities of various nuclear waste categories currently estimated to be generated are given in Table 1-1. The basic strategy for the management of the waste categories is that short-lived wastes should be deposited as soon as feasible, whereas for spent fuel and other long-lived wastes an interim storage period of 30–40 years are foreseen prior to disposal.

The main features of the planned system for nuclear waste management in Sweden are shown in Figure 1-3.

The first construction phase for the Swedish Final Repository for Radioactive Waste, SFR, is now completed and the plant was taken in operation in 1988. SFR may later on be extended to accommodate also waste from the decommissioning of the nuclear reactors. For spent fuel a central interim storage facility, CLAB, was taken into operation in July 1985. This facility has a capacity of 3 000 tonnes of spent fuel, with a possibility to extend it to cover the total Swedish needs.

After approx. 40 years of interim storage in CLAB, the fuel will be encapsulated and deposited in the Swedish bedrock. The encapsulation and disposal facility will only start operation around 2020, and the site has thus not yet been chosen. A minor amount of spent fuel is contracted for reprocessing.

For the transport of spent fuel and other kinds of radioactive wastes a sea transport system is in operation since 1982.

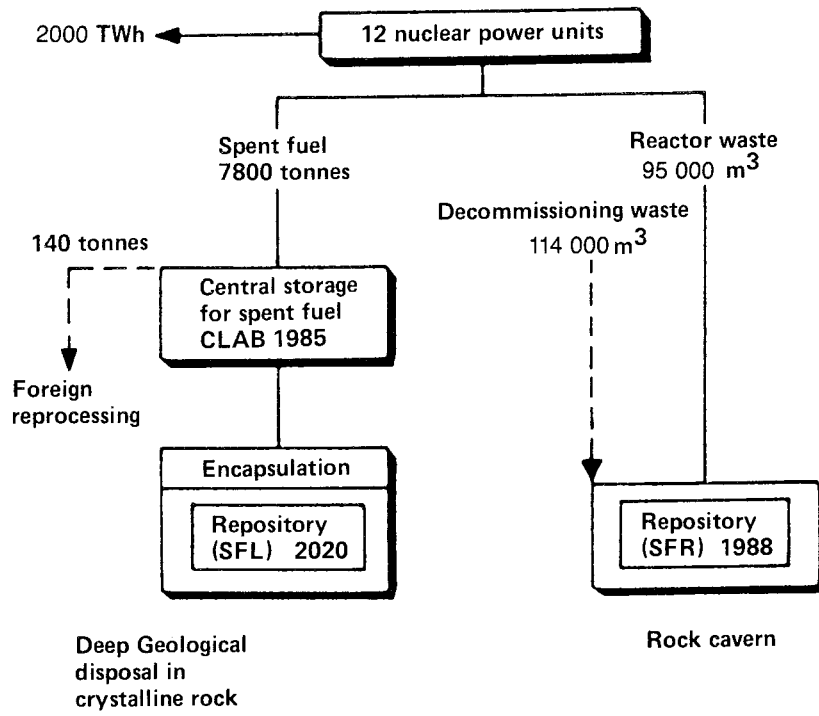

Figure 1-3. Main system for management of radioactive waste in Sweden.

2 NUCLEAR FUEL SUPPLY

In the front end of the nuclear fuel cycle SKB handles matters pertaining to prospecting and enrichment as well as stockpiling of uranium as strategic reserves for the Swedish nuclear power industry. SKB also provides assistance at the request of its owner utilities in uranium procurement.

2.1 NATURAL URANIUM

The Swedish nuclear power programme has an annual natural uranium demand of about 1500 metric tonnes. This demand could be higher or lower depending on a number of factors, which means that the planning of supply must be flexible.

The demand for the period 1988 up to 1997 is 15 000 tonnes. At the end of 1988, the Swedish utilities had contracts for supply of 11 700 tonnes during the same period. Most of the supply is based on long-term contracts. As the prices on the spot market were low in 1988, some spot quantities were purchased.

Natural uranium is delivered to Sweden mainly from Canada and Australia, but also from Niger, Gabon, Peoples Republic of China (PRC) and USA. Canada is responsible for more than 50% of future deliveries under present contracts.

Exploration

Uranium occurs in relatively high concentrations in certain parts of the Swedish precambrian rock. SKB has therefore earlier been conducting exploration at a number of places in northern Sweden. Mineralizations containing at least 6 000 metric tonnes of uranium have been found with concentrations higher than 1 000 g uranium per ton ore. These ores constitute important reserves for the future.

As uranium supply is abundant and the market price is low, SKB stopped exploration at the end of 1985.

Ranstad

Sweden has considerable uranium resources. Most of the proven reserves consist of relatively low-grade shale deposits near Ranstad with about 300 g uranium per ton of shale. These deposits are not exploitable at the present low price of imported uranium.

Market-prices

Figure 2-1 shows the price situation for uranium during the last years. Spot prices were low in 1988.

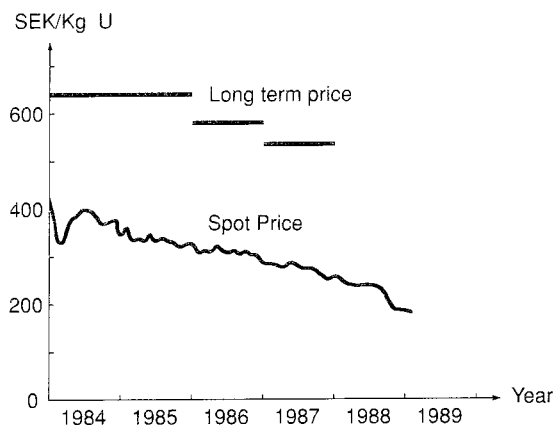

Fig 2 - 1

Figure 2-1. Long term and spot prices for uranium.

Long term price = Average price for long term deliveries to the European Community.

Spot price = Average spot price each month published by the German company NUKEM for non US origin uranium.

The average price for long term deliveries in 1984–1987 to the European Community was considerably higher than spot prices for the same delivery years.

2.2 CONVERSION

Conversion is a chemical process for production of uranium hexafluoride from uranium concentrates.

The world conversion capacity is around 55 000 tonnes of uranium per year while the demand is about 42 000 per year.

The Swedish utilities utilize conversion services from Canada, USA, United Kingdom and France.

2.3 ENRICHMENT

Up to 1983, enrichment deliveries to the Swedish utilities were dominated by DoE in the USA and Techsnabexport in the USSR.

The European enrichment industry became price competitive in the beginning of the 1980-ies. During the period 1983–1985 Swedish utilities signed contracts for deliveries from Western Europe, which started already 1984.

For the period 1988–1990, most of the deliveries to Sweden will come from EURODIF with an enrichment plant in France and from URENCO with enrichment plants in the Netherlands, the United Kingdom and in Germany. Deliveries from the USSR will continue as earlier, while deliveries from the US (DoE) will continue on a reduced scale. PRC has delivered smaller quantities of enriched uranium on a spot basis. This situation gives a reliable supply with deliveries from five different suppliers of enrichment.

2.4 FABRICATION OF FUEL ASSEMBLIES

The Swedish utilities are purchasing fuel fabrication services with the objective of lowest fuel cycle cost. This procedure has led to many orders for ABB Atom, but also orders to the US, German and French companies.

Fabrication of fuel assemblies both for BWRs and for PWRs as well as BWR channels, BWR control rods and other components are made in Sweden at the ABB Atom plant in Västerås.

Fuel fabrication at ABB Atom was around 250 tonnes of UO₂ for BWR and PWR fuel during 1988. Of this volume about 70 (or 30%) tonnes were exported to Finland, Federal Republic of Germany, Switzerland and USA.

In addition, significant quantities of UO₂ powder has been produced for export to the Federal Republic of Germany.

The fuel assembly design, SVEA, where the fuel rods are divided in four minibundles with 4x4 rods separated by a water cross, is now the dominating BWR fuel in Sweden. All of the ABB Atom BWR fuel deliveries in 1988 were of this design.

In 1988 the new type of SVEA fuel, the SVEA-96 or SVEA-100, was further developed and 28 fuel assemblies of this type were loaded in two Swedish BWRs. The SVEA-96 and SVEA-100 fuel, where the fuel rods are thinner and divided in four groups with 5 x 5 fuel rods in each group, allow for more effective In-Core Fuel-Management and more flexible reactor power control characteristics.

2.5 NUCLEAR FUEL STOCK-PILE

The Swedish Nuclear Fuel and Waste Management Co is on behalf of the utilities responsible for stockpiling

enriched uranium and zircaloy corresponding to an electricity production of 35 TWh. This amount has been decided by the Swedish parliament.

Uranium in the above mentioned stockpile, in fuel under fabrication and at the nuclear power stations is sufficient for about two years of operation of all 12 units.

2.6 COSTS

The costs for the front end supply and services of the nuclear fuel cycle in 1988 in Sweden were as shown in Table 2-1 (the production of nuclear electricity was 66.3 TWh in 1988):

Table 2-1. Costs for the front end of the nuclear fuel cycle.

	SEK/kWh	Million SEK in 1988
Natural uranium	0.008	530
Conversion	0.001	70
Isotope enrichment	0.011	730
Fuel fabrication	0.007	460
Strategic stockpile	0.001	70
Total front end	0.028	1860

The costs for nuclear fuel have decreased during the recent years which is shown in Table 2-2.

Table 2-2. Costs for nuclear fuel 1983–1988.

Year	SEK/kWh
1983	0.038
1984	0.038
1985	0.035
1986	0.031
1987	0.028
1988	0.028

3 INTERIM STORAGE OF SPENT FUEL, CLAB

3.1 GENERAL

The Swedish interim spent fuel storage facility CLAB, located on the Simpevarp peninsula adjacent to the Oskarshamn nuclear power station, was taken into active operation on July 11th 1985.

The facility consists of five underground storage pools for in total 3 000 tonnes of uranium. The reception, auxiliary and office buildings are located on ground level. The facility is designed to receive at least 300 tonnes uranium per year which corresponds to the handling of about 100 transport flasks, see Figure 3-1, and some 10-20 flasks containing reactor core components. For the operation SKB has contracted OKG AB, who is one of the SKB shareholders.

3.2 OPERATING EXPERIENCES

After a successful active test period during the second part of 1985 the Swedish Nuclear Power Inspectorate and the National Institute of Radiation Protection granted SKB a permanent operating license valid as from 1985-12-20.

During the years 1986, 1987, and 1988 spent fuel and core components have been received in CLAB on a routine basis from the four nuclear power stations in Sweden. Between July 1985 and the end of 1988 860 tonnes of uranium have been received.

In 1988 95 flasks containing spent nuclear fuel have been received, 76 of which contained fuel from Swedish BWR and PWR reactors and 11 flasks PHWR fuel from

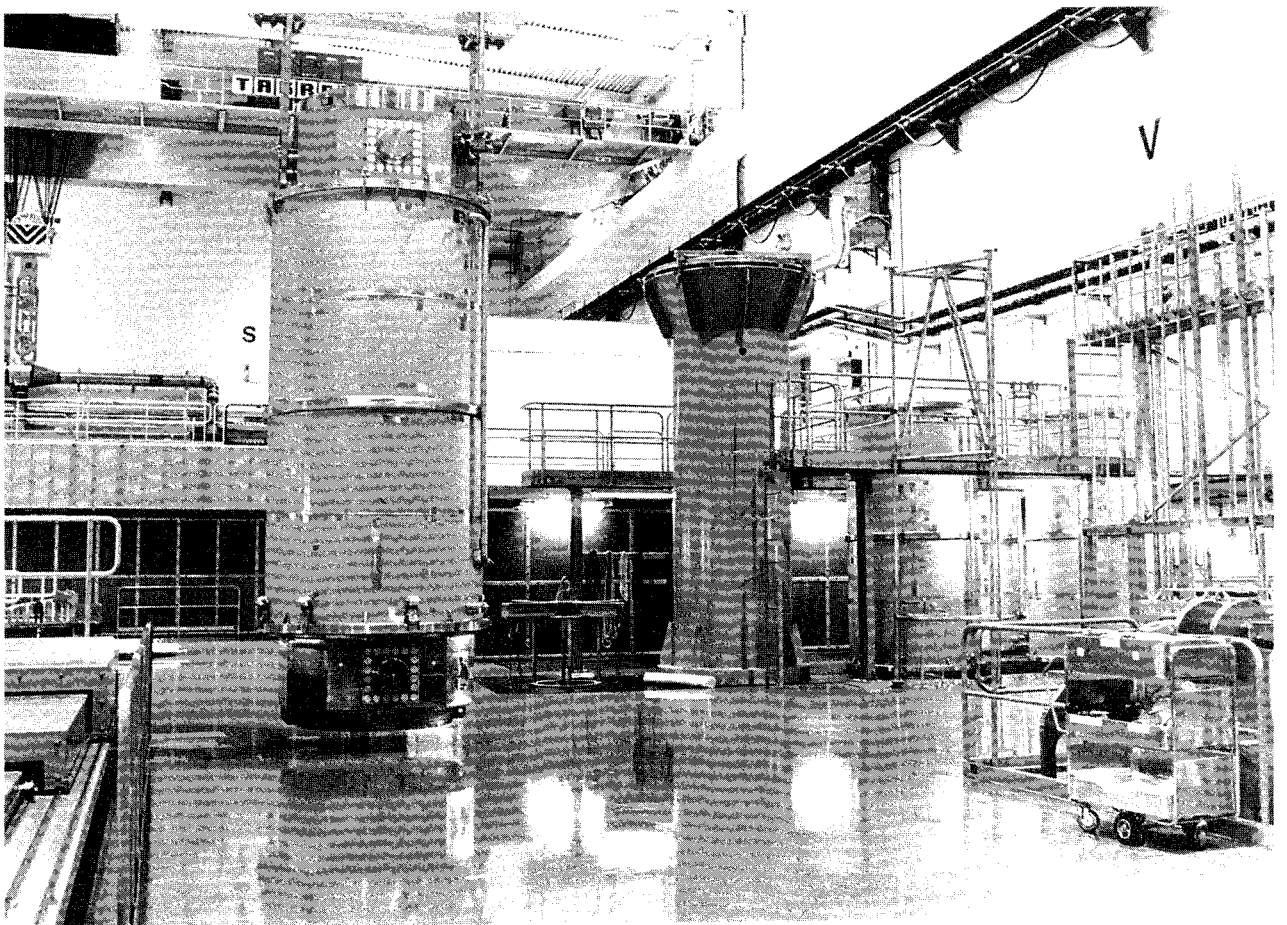

Figure 3-1. Spent fuel transport cask with protective skirt filled.

the old dismantled Ågesta reactor, which fuel has been stored at Studsvik for some 15 years. In connection with a swap of a minor quantity of spent fuel between Sweden and West-Germany, 8 flasks containing MOX-fuel were received. The total fuel quantity shipped to CLAB during the year amounted to 230 tU.

In addition 9 flasks with core components have been received.

The receiving of the West-German MOX fuel and the Ågesta fuel involved handling of five different flask types. All planned shipments from West Germany have been successfully finished.

The performance of the plant has been excellent and the received amount of fuel has been according to the plans. Due to improved operating efficiency, it was possible to switch from two to one shift of fuel handling per day, five days a week. The low total occupational dose in 1987 has been followed with equally good results in 1988, when the dose (66,1 mmanSv corresponding to an individual dose of about 1.1 mSv/person) was 25% of what was expected according to the final safety report.

4 TRANSPORTATION SYSTEM

4.1 GENERAL

The sea transportation system consists of the specially purpose built ship M/S Sigyn, 10 transport flasks for spent fuel, 2 flasks for core components, 27 IP-2 containers (ATB) for transport of low- and intermediate level waste (ILW) and 4 terminal vehicles. One of the terminal vehicles is specially designed for operation in the SFR repository and is therefore equipped with both an electric and a diesel engine, see Figure 4-1. During 1988 a fifth vehicle has been ordered for delivery in May 1989.

4.2 OPERATING EXPERIENCES

During 1988 60 spent fuel casks have been transported by M/S Sigyn from the Swedish reactors to the CLAB facility. From West-Germany 3 transports, including 8 casks with MOX fuel have been transported to CLAB. The last transport of MOX fuel took place in December and finalized the spent fuel swap with West-Germany. 16 on-site spent fuel transports between OKG and CLAB have been performed. 9 casks with spent core components have been transported to CLAB from OKG and Barsebäck respectively. In April 1988 SFR

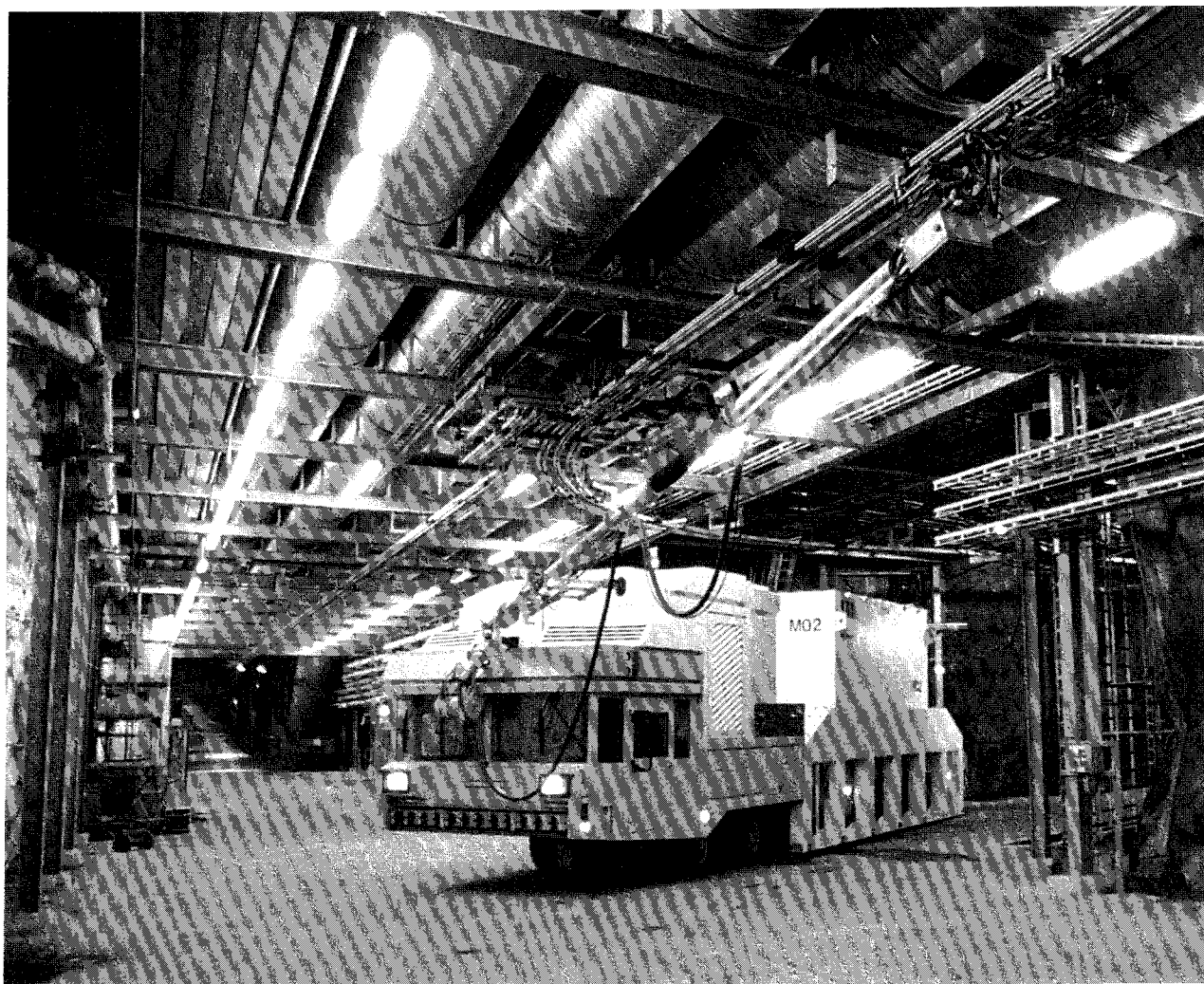

Figure 4-1. The SFR terminal vehicle.

started to receive LLW- and ILW-waste from the Swedish reactors. At the end of the year 61 ATB had been transported to SFR, 16 of which being on-site transports from Forsmark.

M/S Sigyn has been at sea 112 days during the year and sailed 30100 n.m.

The transport and handling of spent fuel casks has up to now proved to be very safe and reliable. The same can be said about the ILW transports. The previously experienced very low dose to the ship crew has only slightly increased even with transport of higher burned up fuel.

5 FINAL REPOSITORY FOR RADIOACTIVE WASTE, SFR

5.1 GENERAL

The Swedish Final repository for Radioactive Waste, SFR, was put into active operation on April, 27, 1988. It is a repository built in the bedrock under the Baltic Sea close to Forsmark nuclear power plant. 60 metres of rock covers the repository caverns under the sea bed, see Figure 5-1. The first construction phase of SFR, which has now been completed includes buildings on ground level, tunnels, operating buildings and disposal caverns for 60 000 m³ of waste. A second phase for additional 40 000 m³ is planned to be built and commissioned around the year 2000.

The waste which will be disposed of in SFR originates from the operation of Sweden's 12 nuclear power reactors and CLAB. This waste contains short-lived radionuclides and can be classified as low- and intermediate level waste. A small amount of similar waste from research and medical activities will also be disposed of in SFR. The total amount of waste from the Swedish program up to year 2010 has been calculated to about 100 000 m³.

All wastes are conditioned at the power plants or at the nuclear research centre, Studsvik. Ion exchange resins are incorporated in either cement or bitumen. Scrap from maintenance work can also be treated in the

same way, if required. These categories are classified as intermediate level waste and need shielding during handling and transport. Low level waste is treated in different ways and finally enclosed in standard freight containers.

In 1988 a total of 1600 m³ of waste have been deposited. All four nuclear power stations have delivered waste. The experiences from the operation have been very good and the doses to the personnel have been extremely low.

The official inauguration of SFR was held on August, 23, by the County Governor, see Figure 5-2. The inauguration was attended by about 200 persons from 17 countries. In connection with the inauguration a seminar was held on Radioactive waste disposal technology and public perception in different countries.

5.2 DESIGN AND CONSTRUCTION

The SFR has been sited under the sea in order to minimize the groundwater flow in the repository area. The hydraulic gradients are at the site very small since the sea acts like an equalizer on the hydraulic conditions in the rock below. The host rock is a crystalline rock, which has proven to be very competent for the excavation of tunnels and various caverns. Engineered barriers are used in order to further reduce the groundwater flow inside the caverns and through the waste.

There are different caverns for ILW and LLW in SFR. The ILW-packages containing most of the activity will be disposed of in a silo structure. The cavern is 70 m high and 30 m in diameter. Inside is a 50 m high concrete silo surrounded with a buffer material. Bentonite is used to give a low permeability. A compacted mixture of sand and bentonite (90/10) is used at top and bottom and granulated pure bentonite is used for the fill around the silo. The space between the waste packages and the concrete construction in the silo will subsequently be filled with concrete.

Wastes containing a smaller portion of the activity content will be disposed of in 160 m long caverns with various cross sections. Three types of caverns are used. The cavern with the largest cross section is equipped with machines for remotely controlled handling, similar to those used in the silo, see Figure 5-3. The waste is deposited in a concrete structure, and finally a concrete lid is put over the waste.

LLW is handled with an ordinary forklift truck in one of the caverns. The waste is deposited in standard

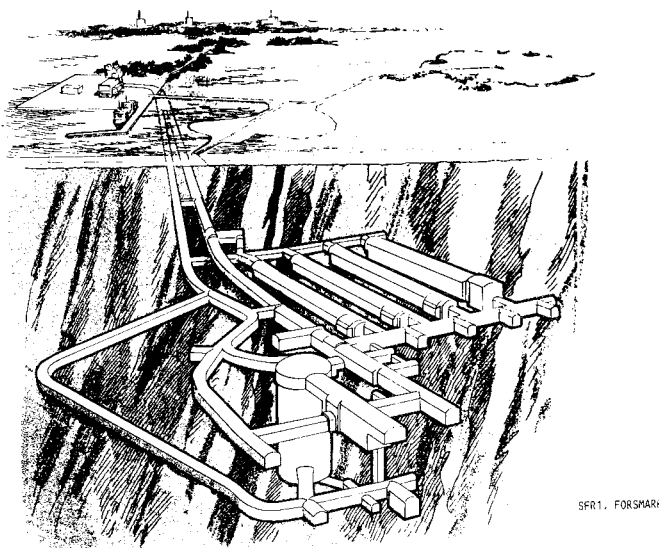

Figure 5-1. Overview of tunnels and storage chambers in the first construction phase.



Figure 5-2. A view from the inauguration ceremony for SFR.

freight containers, which also are used for transport to SFR. This cavern will be sealed without any backfill inside. The third type of cavern is mainly intended for special concrete tanks with dewatered ion exchange resins. Backfilling with concrete and sand will be carried out when the cavern is sealed.

SKB has contracted Vattenfall (The Swedish State Power Board) for the design and construction of SFR. The tunnelling work started in October 1983 and the tunnels reached the repository area in the beginning of 1985. All tunnels and caverns were excavated in March 1986. The construction of concrete structures then started subsequently in the various caverns. The installation of handling machines was carried out during 1987 and the specially designed vehicle for container transport was delivered, see Figure 4-1. After inactive commissioning the rock caverns were ready to receive waste in April. In parallel with the disposal operations in these caverns the commissioning of the silo continued and the silo was ready to receive waste in December.

The construction and the commissioning of SFR have been carried out on schedule. The total cost for the first construction phase has been 740 MSEK (at current prices).

5.3 OPERATION PERMIT

The operational permits for SFR were received at the end of March 1988 from the two safety authorities, SKI and SSI. The permits contain certain conditions of which the most important are:

- Radioactive waste may not be transported to SFR before the waste category has been approved by SKI and SSI for emplacement in SFR.
- Before large quantities of waste can be emplaced in the silo repository, SKB must provide additional information on the sulfate attack on concrete and on the properties of the concrete backfill. No grouting is allowed before this information has been provided.
- Waste to be emplaced in SFR must be registered in a computerized waste record.
- The sealing of different repository parts must be accepted by the authorities. A separate permit for the sealing of the entire repository must be granted by the Government.
- A control and supervision program for the repository shall be performed.
- Recurrent safety and environmental assessments shall be performed.

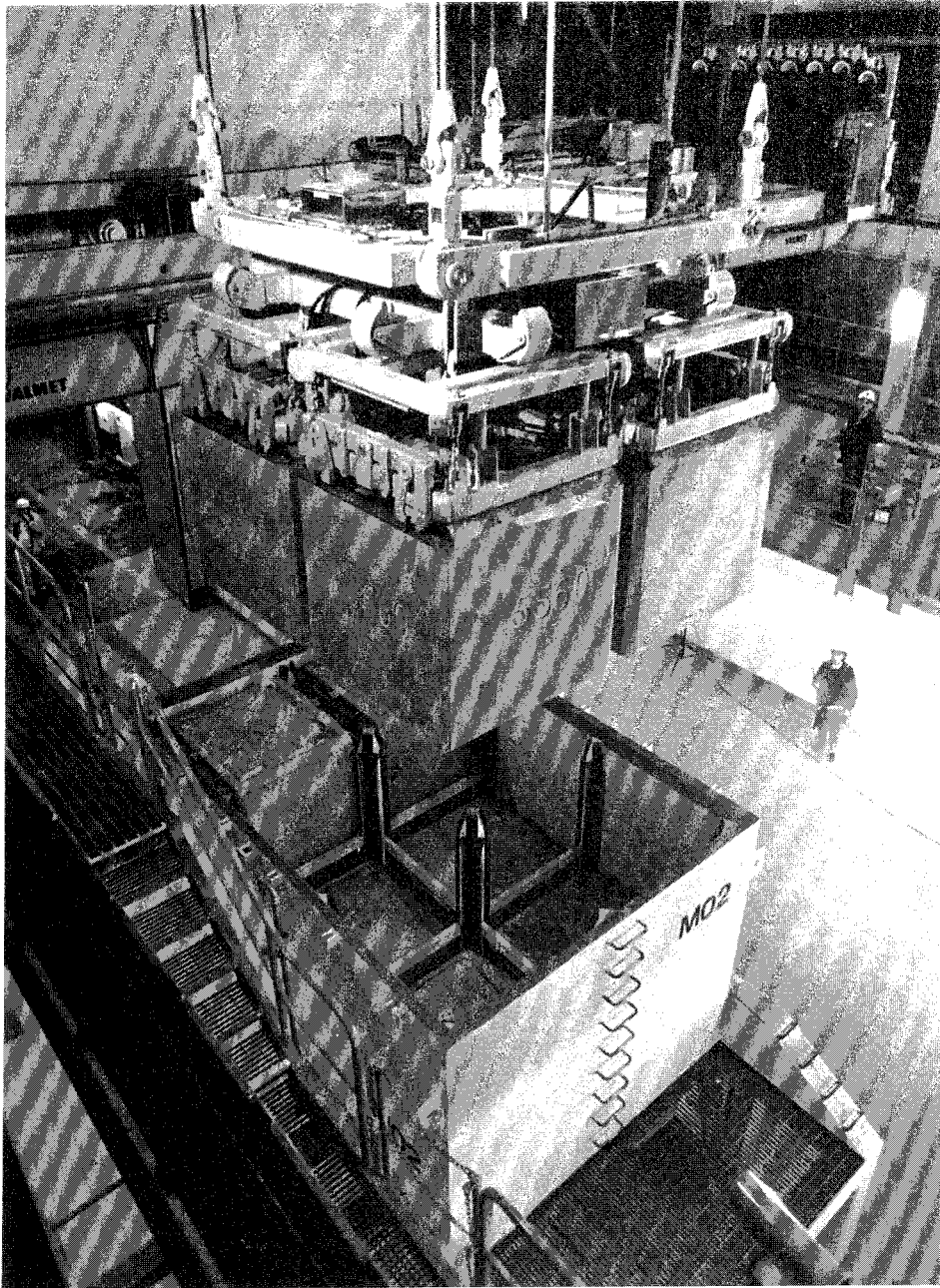

Figure 5-3. Transfer of waste packages from the transport container to disposal in the rock chamber for ILW.

5.4 WASTE ACCEPTANCE

As stipulated in the operational permits all waste that is deposited in SFR should belong to a waste type that has received an approval by the safety authorities. A procedure for the description and approval of waste types has been developed.

As a basis for the approval a special document is prepared, called Waste Type Description (WTD). In

the WTD the functional requirements on the waste package during the sequence from production until disposal are identified and translated into requirements on the waste characteristics. These could be different for different waste types, depending on the handling sequence foreseen.

In the WTD also the QA/QC system for the waste type is described. Control actions are mainly performed by the waste producers. All relevant information about

each waste package is documented and collected in a computerized waste register. Well before the waste is transported to SFR, the contents of the waste register is transferred to a SFR-data base.

The procedure for waste acceptance has been very time consuming and during 1988 only five waste types (of a total of about 30) were accepted for disposal. At first disposal was carried out in the rock chambers but at the end of the year a permit to start disposal in the silo was received. Further information to the authorities is, however, requested before full scope disposal and grouting will be permitted in the silo.

5.5 OPERATION

The operation of SFR has been subcontracted to the Swedish State Power Board, the operator of the nuclear reactors at Forsmark, and is closely integrated in the local organization. The staff for operation and maintenance of SFR consists of about 20 people.

When the facility is in full operation about 6000 m³ is planned to be deposited annually. During the first year of operation SFR has successively been put into active operation area by area, starting with the rock chambers. Up till end of 1988 a total of 1600 m³ of waste has been deposited.

All activities down in SFR are directed and supervised from the operations centre that is located in a building underground centrally in the repository area. The operations centre contains equipment for remote control of all handling machines, including the terminal vehicle, and of the auxiliary systems.

The experiences after one year of operation have been very good. The disposal operations work as planned and the time needed seems to be somewhat shorter than predicted. The doses to the personnel has been very low. The total dose was less than 2 mmanSv in 1988. As all waste that is deposited in SFR is packaged no surface or air contamination has been detected as expected.

6 RESEARCH AND DEVELOPMENT 1988

6.1 GENERAL

According to the Act on Nuclear Activities (SFS 1984:3) the owners of Swedish nuclear power plants must together establish a comprehensive programme for the research and development and other measures that are needed in order to take care of all radioactive wastes from nuclear plants in a safe way.

The Swedish nuclear utilities have commissioned the Swedish Nuclear Fuel and Waste Management Co. – SKB – to establish the programme required by the law. The programme must be submitted to the National Board of Spent Nuclear Fuel every three years starting 1986. The first programme was submitted by SKB to SKN in September 1986 /6-1/ and approved by the government in November 1987 after extensive review by SKN and others.

The work done during 1988 has in general followed the 1986 programme. This chapter gives only a few highlights of the results obtained in 1988. For a more comprehensive account the reader is referred to chapters 10 – 20.

The programme is executed under the leadership of SKB's division for research and development. The staff of the division was increased to 16 persons in 1988. Some 250 scientists, engineers, specialists and technicians were engaged under contracts with universities, technical institutes, research laboratories, engineering firms and industry. The results were reported in 31 technical reports in the SKB-TR-serie, in numerous progress reports and working reports and in communications to several international meetings and to scientific magazines. A list of the more important publications is given in Appendix 2.

The expenditures on research and development within the SKB budget for 1988 were 104.1 MSEK as compared to 92.3 MSEK in 1987. The increase was due to the increasing work at the underground research laboratory.

SKB is also the managing participant in the international Stripa Project and in the Poços de Caldas Project. The expenditures for these projects were 29.1 MSEK of which 9.8 MSEK were SKB contributions and 19.3 MSEK came from participants outside Sweden. The total turnover of the R&D-division was thus 123.4 MSEK.

6.2 SUMMARY OF R&D- ACTIVITIES DURING 1988

6.2.1 Engineered Barriers and Repository Design

In 1986 SKB started a special project for a comprehensive evaluation of the performance, safety and cost characteristics of the so called WP-Cave concept. This concept was originally developed by a group within Boliden WP-Contech AB. Studies of the concept were supported by SKN during 1982–1985.

All analysis work on WP-Cave was completed in 1988 and only reporting remains to be made. Most of the efforts were devoted to safety assessments for the reference design selected in 1987. This design has a capacity of 1100 tonne U in spent fuel, the limit set by the maximum allowed temperature 150°C on the canister surface after repository closure.

The conclusion from the results of the analysis are that it is possible to develop WP-Cave to a repository concept meeting the very high safety requirements on such a facility. It is however doubtful whether the reference design assumed for the study conducted will provide sufficiently powerful barriers to maintain the necessary isolation of the waste. Several options for improvements are however available and the general conclusion was that the concept is technically feasible. The realization of WP-Cave would however be substantially more expensive than for KBS-3. Further more the specific uncertainties in the long term performance are considered to be more pronounced for WP-Cave than for KBS-3. Based on the study SKB has decided not to develop WP-Cave any further as an integrated concept.

In principle the comparison between KBS-3 and WP-Cave highlighted the differences between a concentrated disposal option using a rather small rock volume and a distributed disposal option using larger volumes of rock. The distributed options offer greater flexibility to adapt the design to the local bedrock conditions. The future R&D-work will be directed towards the distributed concept along the lines of KBS-3 as the prioritized reference option.

The studies of the Very Deep Hole (VDH) repository concept have continued with a second stage. Experiences from the deep hole at Grävberg and other deep

holes in crystalline rock have been considered. The reference design has been changed to shallower depth (4000 m) and larger diameter (0.8 m) holes. Problems being investigated are the influence of fracture zones with increased conductivity crossing the hole and also of increased salt content in the groundwater with depth. The study continues through 1990.

The activities on studies of waste form are concentrated on spent nuclear fuel. The work includes fuel characterization, fuel corrosion and modelling. The application of electron probe micro-analysis technique for characterization of high burnup LWR fuel has been successfully tested for the fission products xenon, cesium and neodymium. It was possible to detect compositional changes over distances of 1–2 microns. The results from continued corrosion experiments on samples of a high burnup PWR-rod are in good agreement with earlier results from BWR-specimens. The modelling efforts are still in an early development. A model for the dissolution kinetics for solid uraniumdioxide under reducing conditions has been developed.

The studies of canister materials have also during 1988 been concentrated on copper and steel. For copper the work includes investigations of pitting corrosion and of creep. The work on steel has been directed towards pitting corrosion in particular to develop an improved statistical method for analysing pit growth data. Since 1986 SKB participates in an EUREKA project aiming at development of an out of vacuum equipment for electron beam welding. The project is managed by the Welding Institute in UK. Phase 1 of the project was reported during 1988.

The studies of microstructural changes of and possible silica release from smectite rich clays at elevated temperatures have continued. The results show that silica release might occur in the range 150-200°C. A model explaining the results has been developed. The model is in good agreement with observations from natural deposits of bentonites on Gotland (Sweden) and Sardinia which have been exposed to elevated temperatures for considerable times. The deposit on Gotland is at present at 500 m depth and was earlier at 3000 m depth. It has been exposed to 110 á 120°C for at least 10 million years. The conclusion is that the temperature of the bentonite buffer might be increased to slightly above 100°C without risks for destroying the good sealing properties of the clay.

The finite element code ABAQUS has successfully been applied to model the interaction between canister, clay and rock.

6.2.2 Geoscience

The geoscience programme covers research and developments in geology, geophysics and geohydrology. It also includes the development of new methods, models and instruments for measurements and evaluations.

The geoscience research is to a great extent organized in projects that give opportunity for interaction between the specialized disciplines. Such interdisciplinary approach is used in projects as:

- the planned Swedish Hard Rock Laboratory,
- the fracture zone studies at Finnsjön,
- the study of postglacial movements at Lansjärv.

The activities for the Hard Rock Laboratory – HRL – have continued according to the plan set out in 1986. The regional geology, geohydrology and ground water chemistry have been documented and evaluated. The siting stage of the preinvestigation programme has been completed. The southern part of the small island Äspö 2 km north of the Oskarshamn nuclear power plant has been selected as the site. The site characterization phase started in 1988 and will continue through 1989 before the prediction phase is carried out. The predictions will be completed before the start of excavations which is planned for mid-1990.

In parallel to the preinvestigations extensive planning work has been going on for the construction and operation phase of the HRL-project. A rather detailed programme will be published in 1989 as a background report for the R&D-programme 89.

The fracture zone study at the Finnsjön site continued with the first experiments in phase 3 – the tracer tests. These were started with hydraulic interference tests in order to further establish the transmissive characteristics of the subhorizontal zone 2, which is the main subject of the study. A radially converging tracer experiment has been carried out. Injections of non-sorbing tracers were made in three boreholes at a distance of about 150 m from a central pumping hole. Three sections in each borehole were packed off and used for a total of 11 different injected tracers. The results from the experiment have been offered as a test case to the international INTRAVAL project. The study will continue with a "dipole" tracer test using radioactive tracers in 1989.

Fracture zones have also been investigated at tunnel construction projects in Stockholm and Hylte giving valuable experiences in the use of radar measurements and for the tunneling work to be made at.

A new technique for studying water flow distribution in a fracture zone has been tested at Stripa. Saline water is injected in the zone and the flow paths are mapped by making radar measurements before and after injection. Both single hole reflection measurements and cross-hole tomography measurements were made. The evaluation will be completed in 1989 but preliminary results shows that this could be a very useful technique to map the flow paths.

The investigations of a post-glacial fault in the Lansjärv area in northern Sweden have continued. A 500 m deep cored hole was drilled and logged by geophysical and geohydrological methods. The fault zone was penetrated at 100-150 m depth. The fault scarps were also studied by digging trenches across the zone. The

results so far indicate that all post-glacial movements in the zone have occurred in old fractures. No new post-glacial fracturing of the bedrock was identified. The geohydrologic and geochemical properties of the bedrock do not deviate in any significant way from those found on study sites elsewhere in Sweden. Seismic events have been monitored in the Lansjärv area for a couple of years. Up to February 1989 more than 90 events were detected by the permanent network at three or more locations. The magnitudes were in the range M_L 0.1 – 3.6.

Two-dimensional mathematical modelling is used to study the potential influence of glaciers on the rock mass at depth. The computer model – MUDEC – was checked against measurements at Colorado School of Mines with fair agreement. The work continues.

6.2.3 Biosphere

As during the last years the biosphere studies have been concentrated on the transfer of radionuclides from deep groundwater to man. The investigations have focused on the variability due to normal changes in the primary recipient of groundwater inflow and on the characteristics of sediments in inflow areas in lakes.

Based on field observations and evaluations of transfer factors for systems of lakes in various stages of development due to the ongoing landrise it has been concluded that the variability in dose due to recipient change with time is one order of magnitude at maximum. A typical biosphere as used in the KBS-3 report and in the SFR safety report gives a reasonable upper estimate of doses to a hypothetical critical group. Future comparisons between various concepts could thus use such a standardized biosphere in order to simplify the comparison and not confuse the evaluation with irrelevant uncertainties.

The measurements on Tjernobyf fallout at Gideå and Finnsjön continues. The data will be used to validate nuclide migration models in the shallow groundwater and in the upper soil layer.

6.2.4 Chemistry

The research in this area spans over a wide range of chemistry related subjects like groundwater chemistry, geochemistry, radionuclide chemistry, nuclide transport modelling and validation of models by using data from studies of natural analogues.

A state of the art report on chemical aspects of a nuclear waste repository was prepared based on a special seminar in August 1988.

Groundwater sampling at Äspö and Laxemar within the HRL-project have shown that the water is rather saline. This indicates that the water is stagnant or moving very slowly.

Dissolved organic material has been gathered from deep groundwaters at Fjällveden, Finnsjön and Gideå.

Humic and fulvic acid have been isolated, characterized and used in experiments on radionuclide retention. ^{14}C -analyses on the fulvic acids give ^{14}C -ages in the range 1300-5200 years which is consistently lower than the corresponding ages for ^{14}C in carbonates – 4200–8100 years.

6.2.5 Safety Assessment

The safety assessment activities have been related to four main areas:

- Evaluation of the WP-Cave repository concept and comparison with KBS-3.
- Identification of scenarios. A general study in cooperation with SKI and NEA.
- Study of ^{14}C in reactor systems and in repository environment.
- Further development of the PROPER code system.

The planning of the next major comprehensive safety assessment for a spent fuel repository has started. The main objective of this project called SKB 91 is to evaluate the role of the geologic barrier and to assess the impact of observed variability in geologic parameters on the long term safety of the repository. The exercise will also provide an opportunity to integrate the present knowledge on final disposal and a less conservative reference case than KBS-3 as base for future variation studies and analyses.

6.3 INTERNATIONAL COOPERATION

6.3.1 Stripa Project

The largest of the international activities in which SKB is involved is the International Stripa Project under the auspices of OECD/NEA. The project is managed by SKB and is conducting experiments in the Stripa mine 250 km west of Stockholm. The project is now in its third phase where seven countries – Canada, Finland, Japan, Sweden, Switzerland, United Kingdom and United States of America – are participating. The phase 3 programme includes two major objectives – Site Characterization and Validation (SCV) and Rock Sealing.

Stage 1 and 2 of the SCV-programme were completed in 1988. These stages included preliminary characterization and predictions for the granite body selected for the study. The body is approximately 125•125•50 meters in size. The plans for detailed characterization and validation were worked out in detail.

Closely related to the SCV-study are the developments of

- high resolution and directional radar antennas,
- improved techniques for high resolution borehole seismic measurements,

- fracture network modelling,
- channelling experiments.

The modelling work is conducted by three groups working in parallel. A group from Harwell, UK is supported by the Stripa project and two groups from USA are supported by USDOE. The work of the groups is coordinated and reviewed by a Fracture Flow Modelling Task Force which include specialists from all participants in the Stripa project.

The general objective of the rock sealing tests is to identify suitable grouts and grouting techniques for sealing of fine rock fractures. In 1988 three major parts were conducted of this programme. A large-scale pilot field test was made in the time-scale drift at Stripa. Sodium bentonite clay gels and a cement slurry were used for grouting fractures. The test was very successful and grout penetration was recorded in fractures with only a few tens of microns opening. After grouting the rock permeability was less than 10^{-10} m/s regardless of the original value. Another important part of the rock sealing tests is the ongoing studies of the longevity of the selected candidate grout materials. Preliminary conclusions were reached in this area. Finally the programme for the detailed field tests was formulated and these tests were initiated at Stripa. Four main tests are included in this programme. They include sealing of fractures intersecting a deposition hole, sealing of the disturbed zone around a tunnel due to blasting and due to stress relocation and sealing of a water conductive fracture zone intersecting a tunnel.

6.3.2 Poços de Caldas Project

The three year Poços de Caldas project in Brazil is directed towards studies of natural analogues at the thorium deposit Morro do Ferro and the uranium mine Osamu Utsumi. The project is sponsored by SKB, NAGRA in Switzerland, DOE in UK and DOE in USA. The work in 1988 included mainly field data collection, laboratory tests on field samples and analyses of data obtained. Modelling efforts were initiated. A project workshop on site in Poços de Caldas was held in February 1988. Work progressed according to plans.

6.3.3 JSS-project

All experimental studies of high level waste glass durability, which was performed within the JSS-Project (a joint project between NAGRA, Switzerland, CRIEPI, Japan and SKB, Sweden) ended by December 1987.

This project has been subdivided into five phases, where the bulk of the experimental data were collected

in phases I to III and phases IV and V dealt more specifically with modelling of the interactions in the system glass/bentonite/water/steel corrosion products. In phase V, a glass, MW, developed for the vitrification of Magnox wastes by BNFL at Sellafield was also included in the programme.

The final results of the project were reported at an international seminar held in Stockholm in May 1988. This seminar was followed by the final Steering Committee meeting of project. The major findings of the JSS-Project were summarized in last year's annual report.

6.3.4 Other International Activities

Cooperation and exchange of information on an international or bilateral basis is an integrated part of the R&D-activities at SKB.

International developments in the field have been followed through participation in a number of conferences where papers by SKB staff or its consultants have been presented, see Appendix 2. Staff members of SKB or experts engaged by SKB have also participated in activities within IAEA and OECD/NEA.

SKB has since several years bilateral information exchange agreements with DOE in USA, AECL in Canada, NAGRA in Switzerland, CEA in France, TVO and IVO in Finland and with Euratom, CEC. In 1988 an agreement on information exchange was signed with SCUAE in USSR. This agreement foresees seminars in Sweden 1989 and in Sovjetunion 1990. Information exchange without formal agreements has been made with organizations in the Federal Republic of Germany, Belgium, United Kingdom, Japan and Spain.

During 1988 Swedish specialists and consultants to SKB have worked for longer or shorter periods of time at research organizations in France (CEA, Fontenay aux Roses), USA (Yucca Mountain Project, Las Vegas), Canada (AECL, Pinawa) and Italy (Ispra). Several foreign experts have also worked in Sweden within the framework of the SKB programme.

The cooperation with AECL on the URL project in Canada has continued as planned.

Discussions have also been initiated with AECL concerning joint studies of a natural analogue at Cigar Lake in Saskatchewan in Canada. A three year programme has been proposed.

The participation by SKB continues in the international project HYDROCOIN and INTRAVAL coordinated by the Swedish Nuclear Power Inspectorate as well as in the CEC-sponsored studies CHEMVAL and COCO.

7 SYSTEM PLANNING AND COST CALCULATIONS

7.1 SYSTEM PLANNING ACTIVITIES

The Swedish waste management system is described in Chapter 1. Activities performed by SKB concern implementation, operation and improvement of the different parts of this system. Technological developments are likely to be made during the long time period of the back-end operations, and changes in the system are therefore expected in the long run.

The next major project in the operating parts of the system is the expansion of the storage capacity in the CLAB facility. With present storing technology the available positions in CLAB will be full during year 1996. In 1988 the study on different alternatives was summarized. The decision was taken to implement the technology of closer storing of assemblies in the canisters. Thereby the start of construction of new pools may be postponed for about 6 years. The new pools can also be made somewhat smaller than earlier planned.

In 1988 more detailed preparations were made for the Hard Rock Laboratory, as presented in Chapter 14. The laboratory represents one major part of the program for development of the detailed design of the final repository for spent fuel.

The R&D program has included analysis on alternative concepts for the final repository for spent fuel, such as WP-Cave and Very Deep Boreholes, see Chapter 10. The reference concept is the KBS-3 design.

7.2 REPROCESSING

The Swedish policy of disposal is the once-through strategy without reprocessing of the spent fuel. SKB is therefore actively marketing the existing contracts with COGEMA to other customers.

In the early 1980's spent fuel corresponding to a total of 57 tonnes of U was sent to La Hague for reprocessing. The reprocessing waste was to be returned to Sweden. This special waste would require separate storage facilities and a separate encapsulation process prior to final disposal.

In 1985 an agreement was made with four utilities in West Germany concerning an exchange of the fuel sent to La Hague with Mixed Oxide fuel (MOX) corresponding to about 24 tonnes of heavy metal. When considering the amount of plutonium the two lots contain about the same quantities. In 1988 this exchange was completed.

The MOX fuel is interim stored in CLAB and will eventually be finally disposed of in the final repository for spent fuel.

7.3 COST CALCULATIONS AND BACK-END FEE

According to Swedish law all back-end activities including the decommissioning of the nuclear power plants are the responsibility of the nuclear power plant owners. The costs are covered by funds, one for each nuclear power plant, which collect the money via a certain fee on electricity from nuclear power. The fee is set annually by the government.

Each year SKB calculates the future electricity production and the future costs for the back-end operations related to this electricity production. The results of the 1988 year calculations were presented in PLAN 88 /7-1/. The total future electricity production (from 1988) was estimated to be about 1490 TWh, if all twelve reactors are operated to year 2010. Up to the end of 1987 about 470 TWh have been produced making a total of about 1960 TWh in the Swedish program. For this production a fuel volume of about 7 800 tonnes of U is required.

The total future back-end costs were estimated to be about GSEK 40.7 (price level of January 1988). The figure includes the costs to be paid to COGEMA in accordance with the remaining contracts. The spent fuel is assumed to be disposed of in a KBS-3 repository. Up to and including 1988 already SEK 6.7 billion have been spent. The total cost for the back-end of the number fuel cycle is thus about SEK 47 billion. Excluding the reprocessing costs the breakdown of the costs are roughly:

Transportation of waste	8 %
Interim storage of spent fuel	21 %
Encapsulation and final disposal of spent fuel and long-lived waste	39 %
Final disposal of operational and nuclear power plant decommissioning waste	4 %
Decommissioning and dismantling of nuclear power plants	19 %
Miscellaneous incl R&D, pilot facilities and reprocessing contracts	9 %

Based on SKB's cost calculations and the assumption that each of the twelve nuclear power reactors will be in operation for 25 years only, the government has decided that the fee for 1989 shall be SEK 0.019 per kWh on an average. This is the same fee as for the last six years.

The fee is periodically paid into funds at the Bank of Sweden. These funds are administrated by the state authority, the National Board for Spent Nuclear Fuel, SKN. The total sum in the four funds was at the end of 1988 about GSEK 5.1.

7.4 DECOMMISSIONING OF NUCLEAR POWER PLANTS

During 1988 SKB's engagement continued in the international cooperative program, which is sponsored

by OECD/NEA. SKB is responsible for the program coordinator function.

In 1988 a planning frame was adopted by the Swedish parliament regarding the closure of two reactors. The proposal is that one reactor is taken out of production in 1995 and one in 1996, one reactor on the Barsebäck site and one on the Ringhals site. With respect to this SKB initiated a study regarding the major factors affecting the decision on start of dismantling of the prematurely closed reactors. The conclusion was that safety considerations strongly object the dismantling of a reactor close to one in operation. It was further recommended that no dismantling starts until all reactors at the site have been taken out of production.

8 CONSULTING SERVICES

The achievements in the Swedish Nuclear Waste Management program have been recognized internationally and several foreign organizations have shown interest in utilizing SKB's specialized know-how and experience in their programs. In 1984, therefore, a small group within SKB was set up for marketing and management of consulting services conducted in cooperation with groups and individuals associated to the Swedish program.

From the start in 1984 and up to the end of 1988 about 40 assignments have been accomplished in a variety of areas such as field measurements in boreholes (hy-

drological, geophysical, rock stresses), canister and buffer material studies, feasibility studies and reviews of investigation programs and facilities.

The consulting services performed during 1988 have included a radar borehole measurement in Canada, Finland, Japan and Switzerland, delivery of radar borehole instruments to Canada, geophysical logging in Finland, rock stress measurements in Canada, final reporting of a comprehensive study regarding site investigations in USA, transfer of a geoscientific database to USA and a study on methodology for calculation of back-end costs in Taiwan.

9 PUBLIC AFFAIRS AND MEDIA RELATIONS

9.1 GENERAL

The implementation of the SKB radioactive waste management system needs support by the general public. This is the reason why all kinds of information activities play a very important role in the Swedish waste management program, both locally and on the national level.

The aim, based on the awareness that the Swedish public is entitled to open and comprehensible information on all aspects of the handling and disposal of radioactive waste, has been to give a clear and unbiased description of the main issues today and principal plans for tomorrow.

After Chernobyl the debate on nuclear energy and waste has been reactivated in Sweden, and the government has presented plans for decommissioning two out of the twelve reactors prior to the deadline of 2010 decided upon earlier by the Parliament.

9.2 SKB INFORMATION ACTIVITIES

During 1988 activities within the fields of public information and media relations have continued following established guidelines. Updated exhibitions and printed material have found wide use during increased efforts to receive visitors at the different facilities owned by SKB.

A series of one-day trips was arranged for M.P.-s during the Spring to have them visit the Swedish Final Repository (SFR) close to the Forsmark NPP. This facility for short-lived waste got operational in April and it was formally inaugurated during the Autumn. Press and TV coverage was received in a number of countries.

Domestic media reported during 1988 extensively on the transport of MOX fuel by the SKB ship m/s Sigyn from Germany to Sweden. The two countries had on government level exchanged German fuel for waste resulting from French reprocessing of Swedish fuel. The deal was the result of a 1986 exchange agreement between the two countries to simplify waste management systems in both countries. On a number of other occasions during the year SKB representatives have appeared on Swedish radio and TV programmes. The research work being done on different sites around Sweden has been the subject of local media coverage.

Swedish politicians, other decision makers, foreign specialists and politicians as well as members of the

general public have been frequent visitors to all the different SKB facilities. More than 50 groups came from abroad.

On invitation by local community councils around the country, the SKB management has participated in a number of public meetings at or near the research sites, e.g. the planned underground hard rock laboratory.

The in-house magazine SKB-nytt (SKB News) was published with seven issues during 1988. The distribution covers a wide selection of scientists, researchers and consultants working for SKB.

9.3 PRINTED MATERIAL

Currently available printed brochures in the English language:

- Nuclear Waste (pocket-size folder, code C12 E 922 010)
- Nuclear Waste Management (co-produced with OECD-NEA, code X99 E 842020)
- SFR, Swedish final repository for radioactive waste, (code C003E 818 025)
- CLAB, Central interim storage facility for spent nuclear fuel
- Transporting radioactive waste
- M/S Sigyn
- Stripa, a deep underground facility
- Hard Rock Laboratory, (code C33E 834 010)

These titles can be ordered from SKB, Public Affairs & Media Relations.

9.4 VIDEO CASSETTES AND FILMS

Currently available SKB video/films in the English language:

- CLAB in Action (code C 1002 602)
- SFR - A final repository for radioactive waste (code C 1001 835)
- The Stripa project (code C 1005 936)
- Spent nuclear fuel on the way (code 1003 615)
- Nuclear Fuel and Waste (code C 1004 704)

These titles can be rented from SKB, Public Affairs & Media Relations.

REFERENCES PART I

CHAPTER 1

1-1 NEW SWEDISH NUCLEAR LEGISLATION

Swedish ministry of industry, DSI 1984:18

1-2 KUNSKAPSLÄGET PÅ KÄRNAVFALLS- OMRÅDET 1987

(Present knowledge about nuclear waste 1987)

KASAM, November 1987 (in Swedish)

CHAPTER 6

6-1 Handling and Final Disposal of Nuclear Waste

SKB R&D-Programme 86

Stockholm, September 1986

CHAPTER 7

7-1 Plan 88

Kostnader för kärnkraftens radioaktiva rest-
produkter

(In Swedish)

June 1988

SKB ANNUAL REPORT 1988

Part II

**Research and Development during
1988**

CONTENTS OF PART II

	Page	
10	REPOSITORY DESIGN	45
10.1	General	45
10.2	WP-Cave	45
10.2.1	General on Project Work	45
10.2.2	Thermally Induced Flow	46
10.2.3	Hydraulic Cage	46
10.2.4	Safety Potential of WP-Cave	47
10.2.5	Comparison between WP-Cave and KBS-3	48
10.3	VDH Repository	48
11	WASTE FORMS	49
11.1	Spent Fuel	49
11.1.1	Fuel Characterization Studies	49
11.1.2	Spent Fuel Corrosion Studies	50
11.2	Modelling	50
12	CANISTER MATERIALS	51
12.1	Copper	51
12.2	Carbon Steel	51
13	BUFFER AND BACKFILL	53
13.1	Clay Characterization	53
13.2	Clay Rheology	54
13.3	Modelling Buffer Performance	54
13.4	International Cooperation	54
14	GEOSCIENCE	57
14.1	Overview	57
14.2	Swedish Hard Rock Laboratory – HRL	57
14.2.1	Overview	57
14.2.2	Pre-investigation Phase	59
14.2.3	Construction Phase	60
14.2.4	Operation Phase	60
14.2.5	Miscellaneous	60
14.3	Groundwater Movements in the Rock	60
14.3.1	Overview	60
14.3.2	Fracture Zone Studies at Finnsjön	61
14.3.3	Geostatistical Studies	61
14.3.4	Studies in Connection to Construction Works	61
14.3.5	Flow Distribution in a Fracture Zone	62
14.3.6	Developments in Modelling	62
14.4	Bedrock Stability	62
14.4.1	The Lansjärv Study	63
14.4.2	Computer Modelling of the Rock Mass	65
14.4.3	Studies in Southern Sweden	66
14.4.4	Miscellaneous	66
14.5	Developments of Instruments and Methods	67
14.5.1	Hydraulic Testing Equipments	67
14.5.2	Multilevel Piezometric Monitoring	68
14.5.3	Hydrofracturing Equipment	68
14.5.4	Borehole Radar	68

	Page	
15	BIOSPHERE	69
15.1	General	69
15.2	Natural Ageing of Lake Ecosystems	69
15.3	Characteristics of Sediments in Inflow Areas	69
15.4	Chernobyl Fallout	69
16	CHEMISTRY	71
16.1	Geochemistry	71
16.1.1	Groundwater Analyses	71
16.1.2	Fracture Mineral Studies	72
16.2	Radionuclide Chemistry	72
16.2.1	Solubility and Speciation	72
16.2.2	Organic Complexes, Colloides and Microbes	73
16.2.3	Sorption and Diffusion	74
16.2.4	Radiolysis	74
16.2.5	Concrete	75
16.3	Chemical Transport	75
16.4	Validation of Transport Models	75
16.4.1	Laboratory Experiments	75
16.4.2	In-situ Tests	75
17	SAFETY ASSESSMENT	79
17.1	General	79
17.2	WP-Cave Evaluation	79
17.3	Scenarios	80
17.4	Carbon-14	80
17.5	PROPER Code Package	80
18	STRIPA PROJECT	81
18.1	Site Characterization and Validation	81
18.1.1	Introduction	81
18.1.2	Conceptual Model of the SCV-site	81
18.1.3	Current Status of Investigation Programme	84
18.2	Development of High Resolution and Directional Radar	86
18.3	Improvement of Techniques for High Resolution Borehole Seismics	86
18.3.1	The Coherent Source	86
18.3.2	Processing and Interpretation Routines	88
18.4	Fracture Network Modelling	88
18.4.1	General	88
18.4.2	Development of Computer Codes	88
18.4.3	Data Interpretation and Experimental Support	89
18.4.4	Predictive Modelling	90
18.5	Channelling Experiment	93
18.5.1	General	93
18.5.2	Activities during 1988	93
18.5.3	Results and Discussion	93
18.6	Rock Sealing Test	93
18.6.1	General	93
18.6.2	Major Activities in 1988	94
18.6.3	Pilot Field Test	94
18.6.4	Main Field Tests	94

		Page
19	NATURAL ANALOGUE STUDIES	97
19.1	The Poços de Caldas Project	97
20	DOCUMENTATION	101
20.1	Technical Reports	101
20.2	Contributions to Publications, Seminars etc	101
20.3	SKB Data Base System	101
	REFERENCES PART II	103

10 REPOSITORY DESIGN

10.1 GENERAL

According to the R&D programme 1986, an evaluation of available alternatives will be made before a site and repository system is selected for the Swedish spent fuel. The order in which the R&D-work will be focused is:

- limitation of the number of most promising sites to 3 for characterization around 1992.
- selection of a suitable system of engineered barriers for these sites around 1995.
- selection of the most favorable site.
- optimization of the repository system to the selected site(s).

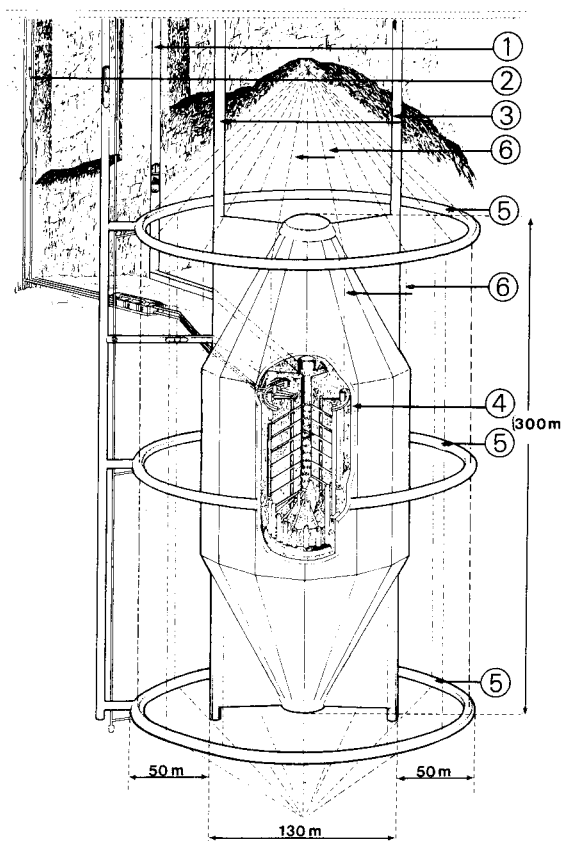

1. Transportation shaft
2. Ventilation shaft
3. Main shaft for excavation and refilling of slot
4. Bentonite-quartz barrier with thickness of 5 m
5. Drift for hydraulic cage
6. Drillhole for hydraulic cage

Figure 10-1. Overview of WP-Cave design.

This means that most of the comparison of alternative designs for the layout of the repository and the engineered barrier system in the repository will be made during the period 1993–1996. Some design alternatives involve, however, specific features that have special demands on the sites or on how the investigations must be done. An example of such a concept is disposal in very deep drilled holes (VDH). Another is the WP-Cave, see Figure 10-1, where the units of waste that are independently protected by unaltered host rock are very large, 1000 tons of U. In order to make it possible to decide whether special geologic or investigational aspects should be taken into account in the site screening stage, it is necessary to evaluate such repository concepts at an early stage.

During 1988 both the WP-Cave and the VDH have been under investigation with regard to how such a repository concept could be applied in Swedish bedrock, what safety potentials it may have, and what the confidence in the results of a safety assessment might be – based on the validity of models and the quality of data available. The studies of WP-Cave have been almost finished whereas the VDH-studies continue.

10.2 WP-CAVE

10.2.1 General on Project Work

In 1988 all planned calculations on nuclide migration were completed. The calculation of fission and activation products with the use of the computer code TRUMP was supplemented with calculations of actinide migration by the use of the computer code TRUCHN.

The analysis was carried out for the Base Scenario, which in 1988 was renamed to the Low Flow Through Case, and also for a new scenario, the High Flow Through Case. The flow in the cases refers to the ground water flow through the bentonite-sand barrier and the interior rock mass. In the Low Flow Through Case this flow contributes to the nuclide release rate outside the bentonite-sand barrier with a release rate, that is in the same order of magnitude as the release rate by diffusion. In the High Flow Through Case the release rate by flow dominates over the release rate by diffusion. The major difference in flow between the two cases is seen during the thermal pulse lasting for about 10 000 years.

Furthermore, during 1988 the performance of the hydraulic cage was discussed in more detail.

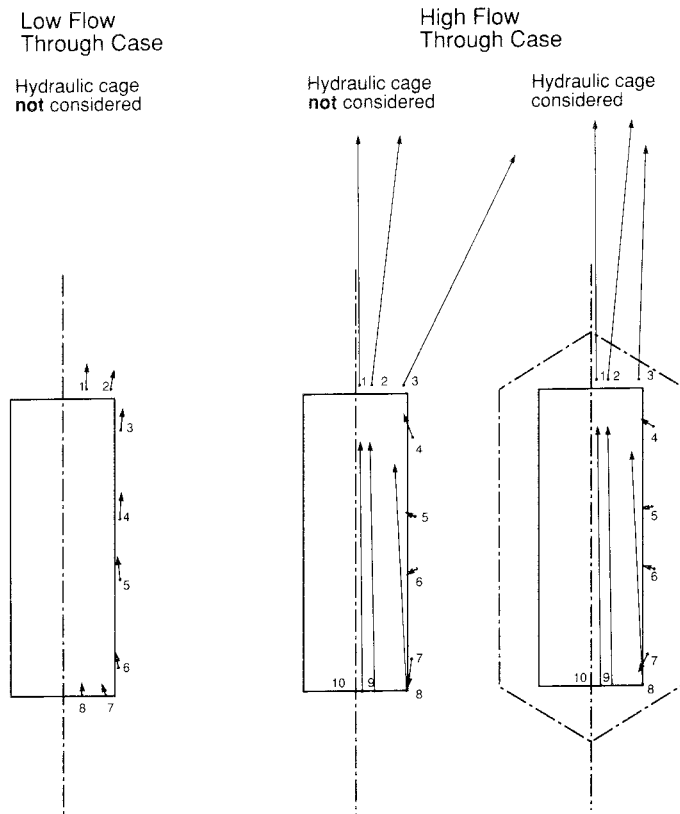

Figure 10-2. Thermally induced flow in two calculated cases. Peak values of Darcy's velocity.

10.2.2 Thermally Induced Flow

The heat generated by the spent fuel will affect the ground water movements outside the bentonite-sand barrier as well as through it. A flow pattern is developed with water moving upwards and with a flow rate that is almost proportional to the prevailing temperature.

The flow rate has in the calculations been presented as Darcy's velocity. Figure 10-2 shows this velocity at different parts of the bentonite-sand barrier for the two cases. The maximum temperature in the interior part is reached within 100 years after repository closure. Table 10-1 lists the major differences in used parameters between the cases.

The flow through the bentonite-sand barrier in the High Flow Through Case is about 20 times higher than in the Low Flow Through Case. At the peak flow rate the amount of water out through the top of the barrier is calculated to be 70 m³ per year and 4 m³ per year respectively in the two cases. The thermal load initially assumed in the Low Flow Through Case has later been decreased. This has resulted in a lower peak temperature in the interior parts of the repository. An adjustment to 160°C is expected to decrease the flow out through the top of the WP-Cave from 4 m³ to about 2 m³ per year.

The volumes of expelled water should be compared to an equivalent volume of 1 m³ per year, which corresponds to the release rate of nuclides from the bentonite-sand barrier by diffusion.

The flow release of nuclides is occurring only in the case of canister collapse during the time the thermal pulse lasts. This is the situation in the WP-Cave study as one assumption is that very short-lived mild steel canisters are used (collapsing after 200 years). If instead long-lived canisters (for instance copper canisters) are assumed, the thermal flow has no major influence on the nuclide release rates.

10.2.3 Hydraulic Cage

In the long run, after the thermal pulse, the hydraulic cage decreases the natural hydraulic gradient through the interior to such an extent, that the flow through the bentonite-sand barrier is maintained on a low level. Then the nuclide release rate from the bentonite-sand barrier is dominated by diffusion.

The effect of the presence of a cage differs dependent on the characteristics of existing water transporting fissures in the rock mass. The two extremes are water flow in fissures with extension in metre-scale perpen-

Table 10-1. Major difference in parameters between the two cases.

	Low Flow Through Case	High Flow Through Case
Thermal load in WP-Cave	1.13 MW	0.6 MW
Resulting peak temperature	280°C	160°C
Hydraulic conductivity in bentonite-sand barrier		
– Upper cone	10 ⁻¹¹ m/s	10 ⁻¹⁰ m/s
– Vertical part and bottom cone	10 ⁻¹⁰ m/s	10 ⁻¹⁰ m/s
Hydraulic conductivity in interior parts		
– All mass	10 ⁻⁹ m/s *	
– Back-filled shafts		10 ⁻⁵ m/s
– Rock mass		10 ⁻⁷ m/s

* The same value as of the rock mass outside the bentonite-sand barrier.

dicular to the flow direction and water flow in “channels” only.

In the first case the drains of the cage could be expected to effectively cross all major water transport paths, while in the second case some channels may be difficult to locate and cross-circuit. The over all efficiency of the cage may thereby differ in the two different cases.

Secondly the diffusion rate of nuclides through the bentonite-sand barrier will differ. The rate is among other things proportional to the square root of the water velocity past the outer surface of the barrier. In case of large-extension fissures the cage decreases the water velocity inside the cage evenly. For a 99% efficiency of the cage the water velocity thus decreases 100 times and the diffusion release rate 10 times. In the other case with “channels” a 99% efficiency would mean that 1% of the water passes through the cage, but the velocity is unchanged in those fissures. Thus only 1% of the initial release rate is obtained and the reduction in release rate corresponds to 100 times.

Thirdly the sorption of nuclides inside the cage is affected. If the water velocity decreases 100 times, and thus the travel time increases 100 times, the retardation of high-sorbing nuclides becomes significant. In the other case, the travel time is unchanged in the “channels” passing through the cage, and no extra retardation is obtained by increased sorbing rates.

The analysis was not intended to compare the most favourable rock characteristics. The intention has merely been to identify the key questions of performance for different rock properties.

10.2.4 Safety Potential of WP-Cave

The analysis of safety potential has included the calculation of nuclide migration to surface and dispersion in the biosphere. All calculations have further assumed the use of mild steel canisters.

The result, presented in Sv/a, shows about a 20 times higher peak release rate of fission and activation products in the High Flow Through Case than in the Low Flow Through Case. For actinides the difference in peak release rates is about a factor of 5.

Another parameter of importance is the volume of water the released nuclides are diluted in. One Large Dilution assumption is in 500 000 m³/a of water in a well for drinking water. A Small Dilution assumption is in 2 000 m³/a of water only. The difference in peak release rates is a factor of about 10 for fission and activation products and of about 200 for actinides.

The calculated total release rates of nuclides, with two peaks in different times for fission-activation products and for actinides, are both considered to be too high in the High Flow Through Case and the Small Dilution. But the rates are on a low level in the Low Flow Through Case with the Large Dilution. In all calculations the release rates of fission and activation products are higher than those of actinides.

The conclusion of the results is that the WP-Cave is judged to be possible to develop to a repository concept that fulfills high demands on safety. But it is doubtful whether the design assumptions assumed for the conducted study will provide barriers powerful enough. Several options for improvements of the barrier functions, especially those of the bentonite-sand barrier are

available. A dramatic change would further be obtained if the short-lived steel canisters are exchanged with long-lived copper canisters.

The report on the safety analysis is scheduled for spring 1989.

10.2.5 Comparison between WP-Cave and KBS-3

The result of a technical comparison between the WP-Cave concept and the KBS-3 concept is summarized in Section 17.2.

10.3 VDH REPOSITORY

A second stage in a feasibility study and assessment of the economic potential of storage of nuclear waste in

very deep boreholes started late 1987 and was concentrated towards the quality of the properties of the rock at large depths which are important for the isolation of spent fuel and the methods and technique for the investigations and drilling.

Experience from the running Grävberg drillhole at 6 km depth was used and a survey of geoscientific results from known deep boreholes in crystalline rock was made. The second stage "Outline design and quality assurance review" ended with the recommendation to proceed to the third stage. Larger diameter (0.8 m) of boreholes but shallower depth (4 km) should be considered. The effects from one or more fracture zones with higher hydraulic conductivity crossing the boreholes should be considered as well as from saltwater groundwater at depth.

11 WASTE FORMS

11.1 SPENT FUEL

The activities on waste form studies have been concentrated on spent fuel. All SKB work on vitrified high level waste, which was performed within the JSS project, waste were terminated by December 1987, see section 6.3.3. After that date, all activities have been concentrated on spent fuel.

The close contacts with other groups in the world performing similar studies have been continued. This year the annual workshop on spent fuel, the eighth one in the ongoing series, was held in the Federal Republic in Germany and arranged by Transuranium Institute, Karlsruhe.

11.1.1 Fuel Characterization Studies

The application of the electron micro-probe analysis technique to the examination of a spent fuel specimen at the individual grain level has shown that the technique has the capacity to distinguish and measure fairly

small compositional changes over short (1-2 microns) distances with satisfactory sensitivity and accuracy for the fission products xenon, cesium and neodymium /11-1/. With some changes in the measurement technique, further improvements in accuracy can be attained, and it is possible that even strontium could be measured with sufficient accuracy to enable significant concentration changes to be detected.

In the fuel specimen examined, which had experienced a power ramp up to 43 kW/m such that appreciable fuel restructuring and fission product migration and release had occurred, steep local concentration gradients probably associated with grain boundary sweeping were detected and measured. An enhanced cesium/uranium ratio in fuel grains at a crack position was tentatively detected.

Application of the technique to the examination of high burnup commercial LWR spent fuel specimens is planned for the near future. Later, specimens which have been exposed to leaching will also be examined.

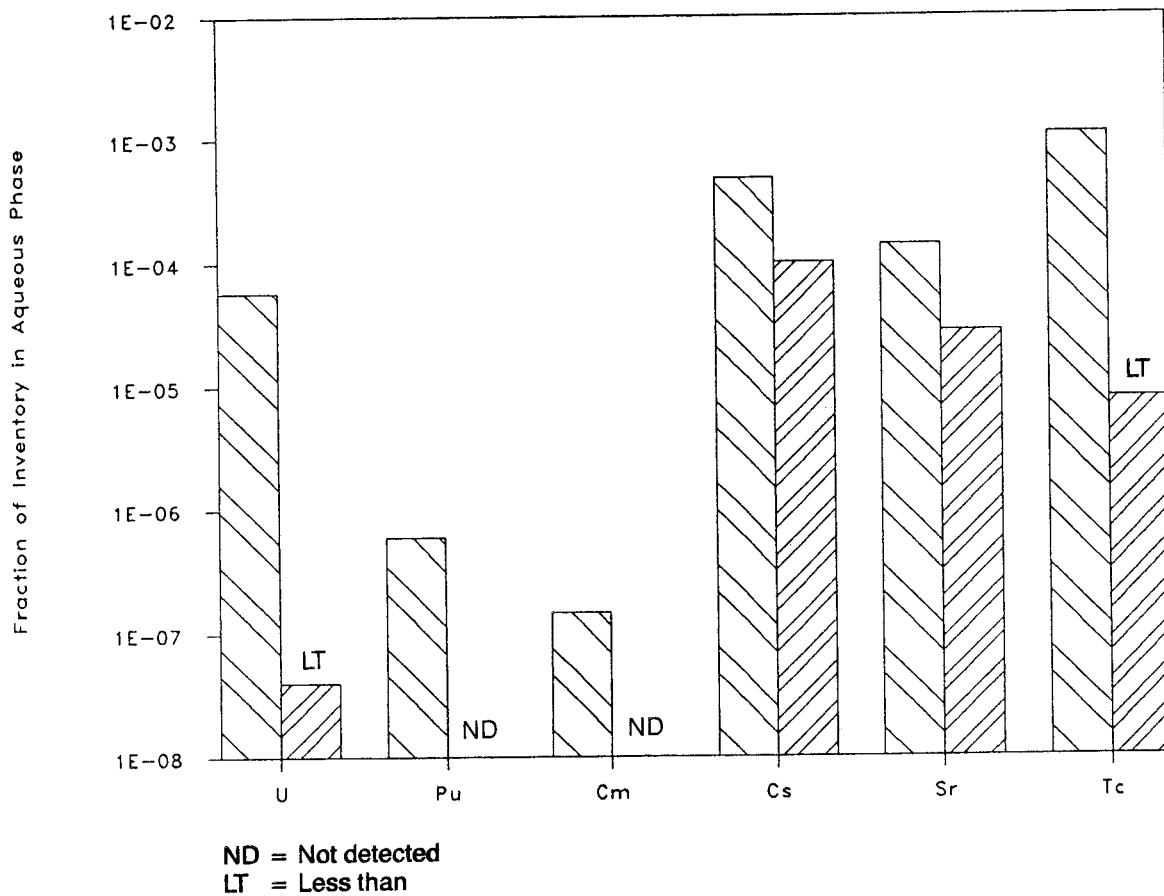

Figure 11-1. Comparison between release fractions of actinides and fission products.

11.1.2 Spent Fuel Corrosion Studies

During 1988, PWR experiments with contact times in synthetic groundwater of 436 and 686 days were evaluated. This corresponds to a cumulative contact time of about 1000 days. The results are in accordance with what has been found for BWR fuel after similar contact times.

Experiments carried out under reducing conditions, imposed by means of hydrogen gas in the presence of a palladium catalyst, also confirm the previous findings from BWR fuel, i.e. the uranium concentrations in solution drop to near the detection limit. However, the effect on the Sr release is far less pronounced, corresponding to a decrease in release fraction of about a factor of five. A comparison between the release fractions of actinides and fission products is shown in Figure 11-1.

For the experiments using rock-core reduced groundwater, the results were in between those obtained for oxidizing conditions and those obtained for H₂/Pd reduced water. However, these results are not yet fully evaluated and no definite conclusions can be drawn at this stage.

The remaining PWR and BWR specimens have, with a few exceptions, been reserved for long term exposures. At the end of these contacts, the specimens will be examined and the results correlated with the data from the leach solution analyses.

11.2 MODELLING

The work on developing a model for spent UO₂ fuel dissolution has continued. The dissolution kinetics of UO₂(s) reducing conditions have been studied experimentally under both static /11-2/ and flow /11-3/ conditions, and numerical modelling of the results have also been performed /11-4/. The rate of dissolution has been determined as a function of the acidity of the solution in the pH range 3 to 9. The rate order with respect to [H⁺] suggests an hydroxo promoted dissolution reaction via the formation of a >UO₂ - H⁺ surface complex.

The effect of other important groundwater ligands in granitic groundwater, like HCO₃⁻/CO₃²⁻, on the kinetics of dissolution of UO₂(s) has also been studied. The results indicate that the rate of dissolution is only dependent on the pH and is not affected by HCO₃⁻.

After finalizing this part of the programme, the research activities has been concentrated on oxidative dissolution. The reason for this is that although reducing conditions can be expected in deep granitic groundwater, local oxidizing conditions are believed to be at hand at the fuel surface, mainly due to α-radiolysis.

As a first step in this part of the programme, available literature data on spent fuel and UO₂ dissolution has been compiled and evaluated. The results of this study will be published during 1989 /11-5/.

12 CANISTER MATERIALS

During 1988, the studies of canister materials have been concentrated on two candidate materials, copper and carbon steel.

12.1 COPPER

The investigations on copper during 1988 include continued evaluation of pitting corrosion under reducing conditions and studies of creep in copper at low temperature. For pitting studies, the preliminary results were found to be indecisive and will be continued during 1989.

The major part of phase one of the experimental studies of creep in copper were finished in 1987. This phase has included studies of uniaxial creep in oxygen free copper as well as in welded material. The all weld metal specimens were produced by multiple-pass electron beam weld in order to produce a wider fusion zone. The heat affected zone (HAZ) structure was simulated using heat treatment. In addition to separate testing of weld metal, HAZ and parent material, tests have also been performed on cross weld specimens from a single pass electron beam welding. In addition to these uni-axial tests, welded thin-walled tubes under over-pressure have also been investigated. The data have been reported in /12-1 and 12-2/.

This investigation revealed considerable differences in creep deformation and rupture strength between different zones in an electron beam welded joint in OFHC copper, the weld metal being weakest and the heat affected zone being strongest. These differences resulted in a concentration of the deformation in cross-weld specimens to the weld metal. In internal pressure tested tubes, stress redistribution resulted in an equal or even greater deformation in the parent metal.

Since the creep testing was performed at, or slightly above, the expected service temperature, the stress levels had to be rather high in order to get reasonable rupture times. Unfortunately, the stress ranges used were on the boundary between power law creep and power law breakdown. Therefore, extrapolations to the expected service stress levels are somewhat uncertain. To enable extrapolation to low stress level where power law or even dislocation creep is dominant, creep tests

series have to be performed at higher temperatures. This will also shed some light on the possible presence of ductility minima. Such tests are in progress and will continue during 1989.

In 1986 SKB joined a EUREKA project aiming at developing out-of-vacuum equipment for electron beam welding. The project is managed by the Welding Institute, UK. The Phase I of this project has been finalized and reported during 1988.

12.2 CARBON STEEL

The major part of the study of pitting corrosion on carbon steel, which started at Harwell Laboratories, UK, in 1986 has been finished. Only a few tests aiming at long time exposure are still in progress.

Much of the effort during this period has been devoted to the development of an improved statistical method for analysing pit growth data. The progress of the work during 1988 is reported in /12-3/. The Extreme Value Statistical analysis of results has shown that in some cases these correlate most closely with a limited distribution function, but in other cases an unlimited exponential distribution yields the best fit. This equivocal position was unexpected because it was anticipated that mass or charge transport limitations would set an upper limit on the pit depth and hence cause the data to fit limited distributions. Despite the uncertain position mentioned above, it still remains untenable to accept that there is no physical limitation to the depth to which pits grow in a fixed time. There are also indications from the statistical analysis that the results may be tending towards a limited distribution at longer times. This is reason why long term experiments are in progress.

A preliminary assessment of the corrosion behaviour of a single pass electron beam weld in thick (150 mm) forged carbon steel has been made. This was done by means of scanning electrode measurements of the weld zone in aerated and deaerated 0.1M NaCl solution and a synthetic groundwater. These short term assessments showed that the weld and its associated heat affected zone had corrosion properties at least equal to the parent material. This implies that such welds should not be subject to enhanced attack /12-4/

13 BUFFER AND BACKFILL

13.1 CLAY CHARACTERIZATION

Smectite clay used as canister envelope or as sealant in plugs and the fracture system in rock will be exposed to a temperature cycle due to the decreasing heat power of the spent fuel with time. This may affect the sealing ability in two ways 1) the clay mineral may be altered resulting in reduced swelling and gel forming capacity and 2) the microstructure may become temporarily or permanently altered by which the hydraulic conductivity can be significantly changed.

Hydrothermal tests on Wyoming bentonite up to 250°C and one year produced samples that were analyzed during 1988 by XRD, electron microscope and rheological tests. Silica release was documented to take place in the temperature range of 150°C – 200°C /13-1/.

The test results form the basis for an outline of a model of microstructural changes and silica release, see Figure 13-1.

Parallel to systematic experimental and theoretical attempts that are being made for identification of the criteria which determine the chemical stability of smectite minerals, natural smectite minerals that have been exposed to conditions that are similar to those in repositories are of particular interest. Two cases were

studied, one on Sardinia and the other from southern Gotland (Hamra), Sweden. The more than 10 m thick Sardinian bentonite bed, which is located below 2 m rhyolite rock and presently exploited for the production of commercial bentonite, was very significantly heated to more than 200°C while at more than 4 m depth the temperature did not exceed 80°C. The mineralogical and rheological tests show very small changes in the composition and properties of the clay series except for the clay/rock contact.

The bentonite bed at Hamra is assumed to be of Ordovician age and is 0.3 m thick located at 515 m depth at present and earlier at about 3 km depth with 110°C à 120°C temperature for at least 10 million years.

XRD analysis, electron microscopy and rheological properties evaluated by geotechnical testing form the basis for the conclusion that the geological evidences are in agreement with the model, see Figure 13-1, because the formation of illite/smectite mixed-layer products is negligible or non-existent in the case of Hamra /13-2/.

In cooperation with CEA, France a high temperature test is running with dense smectite clay in a simulated deposition hole in Stripa. The hole is planned to be excavated by overcoring in 1990. A radiation test with SKB

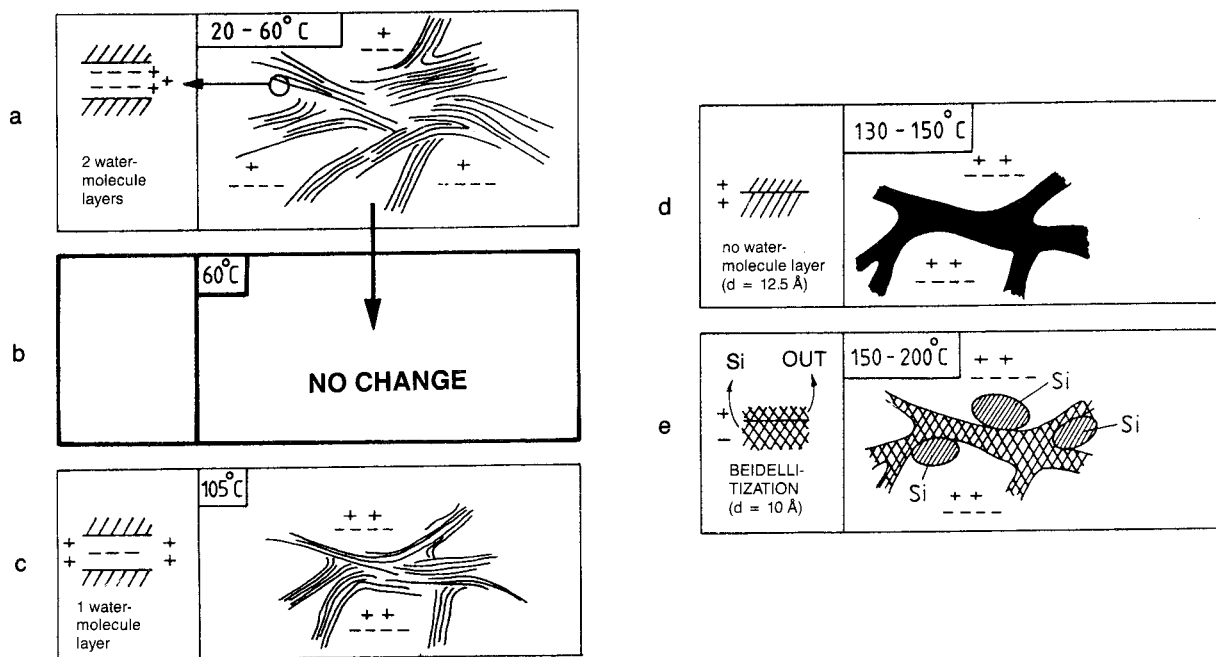

Figure 13-1. Schematic tentative model of microstructural changes and silica release at high bulk density.

reference clay, Mx-80 and the French clay started in April in Saclay and run through with Co-60 irradiation more than 3000 Gyh⁻¹.

13.2 CLAY RHEOLOGY

During 1988 the rheological properties of sodium smectite clay (Mx-80) were studied by laboratory tests. The investigations include determination of the hydraulic conductivity, the undrained stress strain-strength properties, the compression and swelling properties in drained and undrained conditions and the undrained thermomechanical properties /13-3/.

The data form the basis for material models which can be used in calculations of the mechanical behaviour of the bentonite as buffer material in deposition hole.

13.3 MODELLING BUFFER PERFORMANCE

The finite element code ABAQUS was used during 1988 in order to calculate the interaction between canister and dense bentonite buffer clay. Data were used from earlier three tests /13-4/ when simulated rock shear with water saturated Mx-80 and copper canister in 1:10 scale were tested with varied shear rate.

A rate dependent stress-strain relation were used based on triaxial testing. The calculated deformed model canister, see Figure 13-2, the calculated total forces, stresses and strains, see Figure 13-3, agreed well with the test measurements.

The density of the buffer material was varied in the material model. A low density protects the canister from the plastic deformation, see Figure 13-4. /13-3/

13.4 INTERNATIONAL COOPERATION

In the Stripa Project phase 3, activities on sealing in fractured rock are included, see Chapter 18.

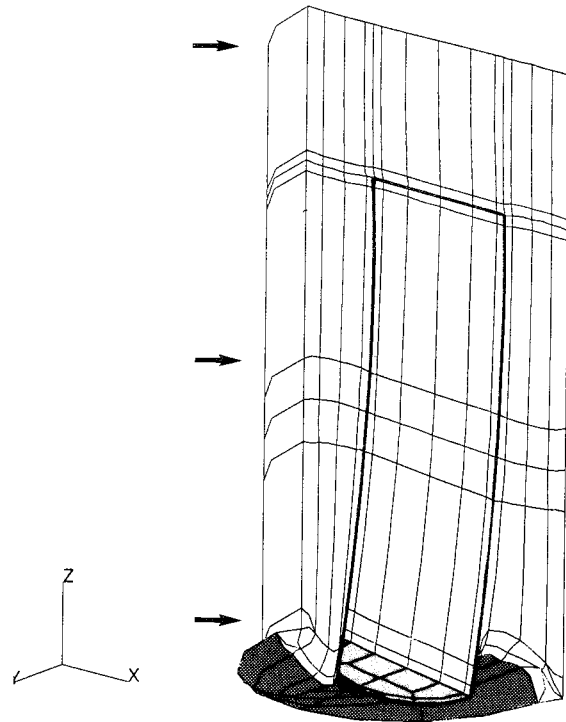

Figure 13-2. The calculated deformed structure. The canister is marked with thick lines. The deformations are enlarged 3 times.

CEA, France and SKB cooperate in the field of clay research, see Section 13.1.

A workshop on Artificial Clay Barriers was held at Lund Oct 5-7. The workshop was organized by SKB in cooperation with OECD/NEA and CEC with three sessions dealing with longevity, transport phenomena and rheology /13-5/.

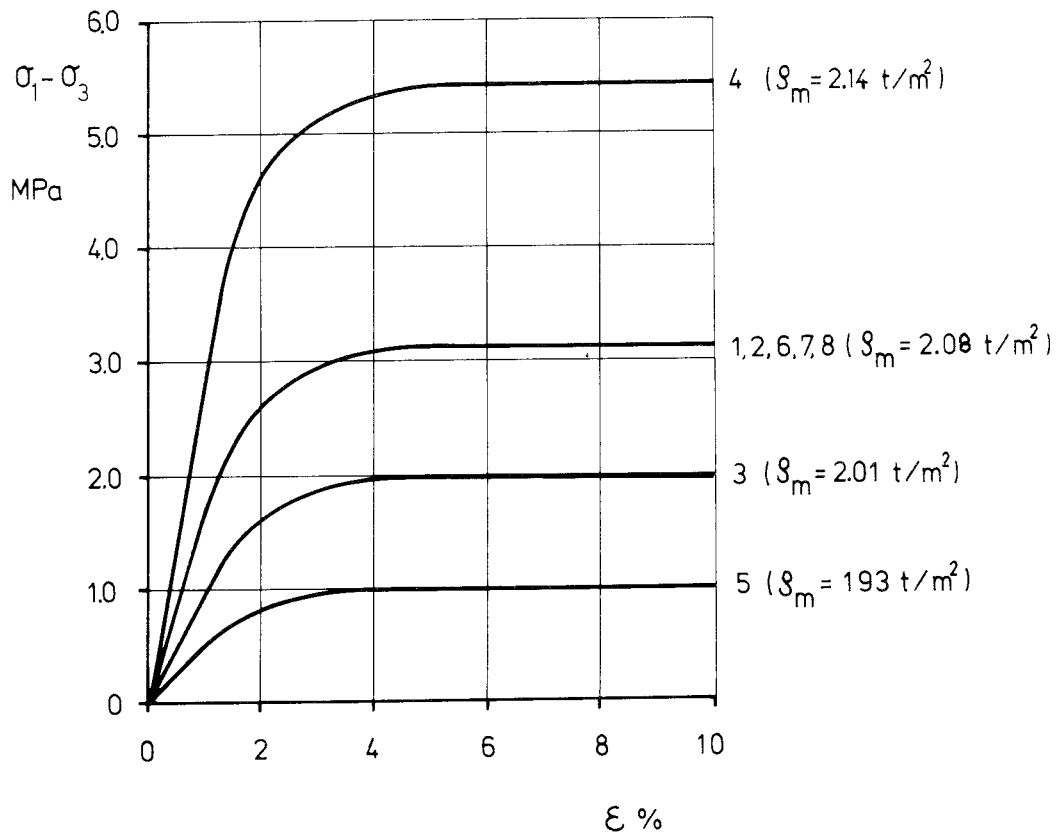

Figure 13-3. Clay material models at the different calculations.

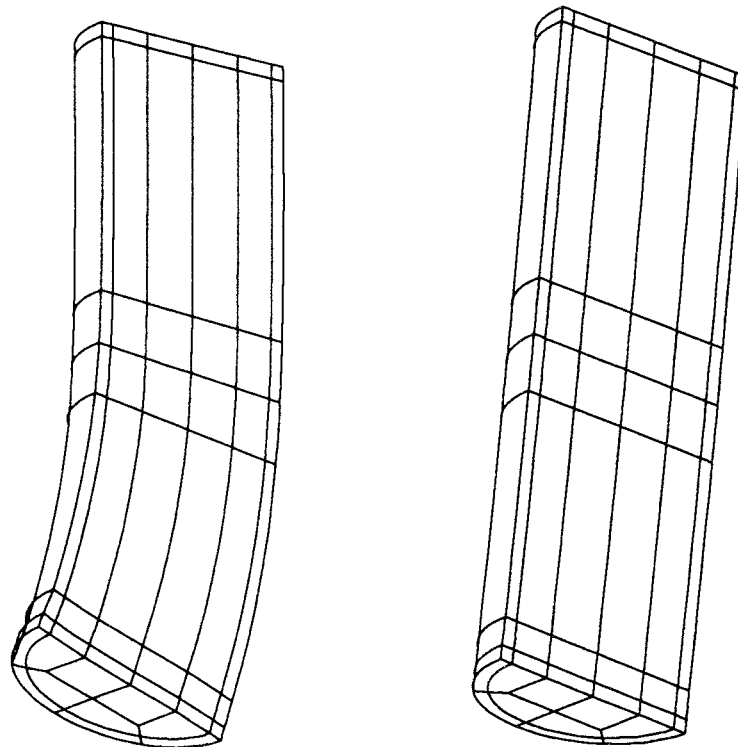

Figure 13-4. The deformed canisters after 9 mm displacement at the clay densities $\rho_m = 2.14 \text{ t/m}^3$ (left) and $\rho_m = 1.93 \text{ t/m}^3$.

(The displacements are enlarged by a magnification factor $F_m = 2.5$.)

14 GEOSCIENCE

14.1 OVERVIEW

The geoscience programme covers research and developments, in geology, geophysics and geohydrology and also includes development of new methods, models and instruments for measurements and evaluations.

The overall objectives and main activities of the geoscience programme 1987 – 1992 are expressed quite in detail in the SKB R&D-Programme 86, /14-1/.

The geoscience research is to a great extent organized in projects that give opportunity for interaction between the specialized disciplines. Interdisciplinary approaches are used in projects as:

- the planned Swedish Hard Rock Laboratory,
- the fracture zone studies at Finnsjön,
- the study on postglacial movements at Lansjärv.

The activities for the Hard Rock Laboratory – HRL – have been executed in accordance with the planning. The regional geology, geohydrology and groundwater chemistry has been documented and evaluated. Work on a thorough characterization of the target area Äspö is in progress. Three deep cored holes have been drilled on the Äspö island and one deep hole on the reference site Laxemar.

Phase 3 of the fracture zone study at the Finnsjön site is in progress. The projects tracer tests are also test cases for the international INTRAVAL-project, see Chapter 16.

The study of post-glacial movements in the Lansjärv area has continued as planned. Drilling through the zone with expected postglacial movements started fall 1987. During 1988 testing has been performed in the hole. A study of fracture minerals has been carried through. A final evaluation of the Lansjärv study is planned to be reported 1989.

14.2 SWEDISH HARD ROCK LABORATORY – HRL

14.2.1 Overview

Whereas the research activities at the Stripa underground laboratory will be completed in the early 1990's, it has been deemed to be of high priority to build an underground research laboratory where continued research can be pursued at a high scientific level to broaden the available body of knowledge. The main objectives of the laboratory have been developed during the year. They are to:

- test and verify methods of site characterization,
- refine and test methodology for adaptive design and construction of a repository,
- collect data of significance for the safety of a repository and the analysis of that safety.

The objectives of the Hard Rock Laboratory have been set to tie in with the overall objectives of the SKB programme. It is thus important to:

- verify that pre-investigation methods used for characterizing the rock provide data on factors pertinent to safety,
- develop and verify the efficacy of the methods in detailed characterization before 1995, when they will be applied to the proposed sites,
- refine and, in a large rock mass at the actual repository level, test the methods and models for groundwater flow that are essential for optimization of the repository system and for the safety analyses required for a site licence application around the turn of the century,
- provide access to rock to refine and develop high standards of design, construction and operation of a repository before start of construction around 2010,
- test, investigate and demonstrate components in the repository system of significance for the long-term behaviour of a final repository at the actual repository depth to full scale and under representative conditions. Tests shall be performed to an adequate extent with respect to time and geometric scale to provide basic data for the necessary permits to be issued to start construction around the year 2010.

The work on the project started towards the end of 1986. The activities can be grouped in three separate phases, pre-investigations, construction and operation. It is planned that construction will start in 1990 and that operation of the laboratory will be able to commence in 1994. Investigations and research will be performed in all phases.

Pre-investigations

The aim of the current phase – pre-investigations – is to site the laboratory, set up conceptual models to different scales that describes the natural conditions in the bedrock and to predict the changes that will occur during construction of the laboratory.

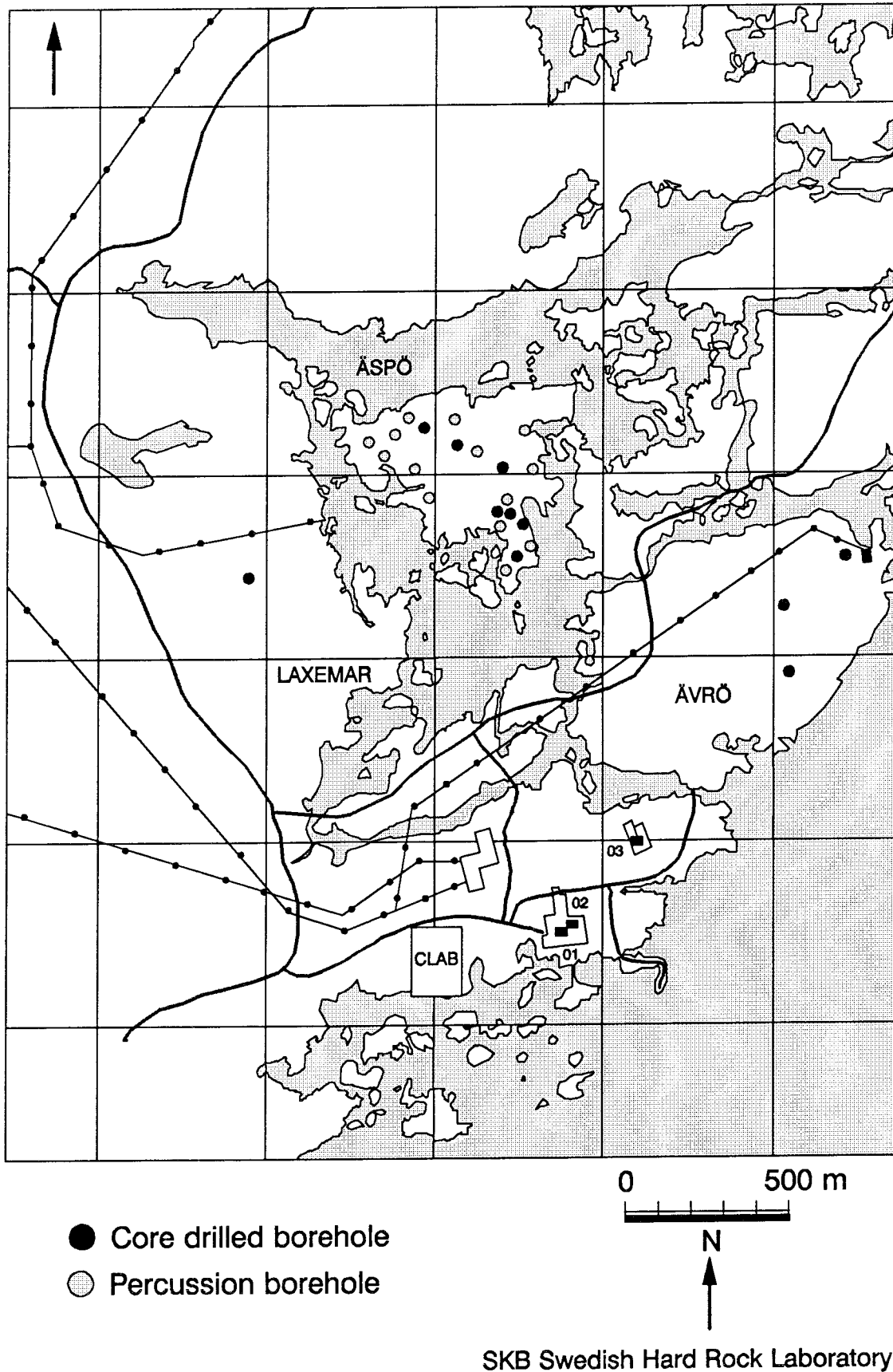

Figure 14-1. Äspö with environs.

In view of existing services and other infrastructure it has been proposed that a location at CLAB (Oskarshamn) or in its vicinity be investigated. Evaluations of the regional setting and target area characterizations have been presented. The south part of the island Äspö has been selected as the site for the HRL, Figure 14-1.

Construction

Phase 2 – Construction – is planned to start in the summer of 1990. A tunnel will be blasted to about 500 m below ground level. The predictions from the earlier phase will be checked and discrepancies explained. The construction work is divided into two steps. The first will include tunnelling to a depth of 350 m. The second step will proceed after a delay of up to six months to permit updating of the characterization of the lower levels. The second step will include tunnelling to 500 m and excavation of parts of the experimental area. It is expected that approvals from pertinent authorities for construction of the laboratory will be obtained until mid 1990. During construction it will be possible to check the predictions set up during pre-investigations.

Operation

The third phase of the project – Operation – is planned to commence in 1994 and may last up to several decades. The experimental programme for the Operation Phase is still in the planning stage.

14.2.2 Pre-investigation Phase

The phase has been divided into three separate stages. The first stage is the Siting Stage. The second is the Site Characterization Stage and the last the Prediction Stage.

The Siting Stage started 1986. The stage includes all data gathered up to start of diamond drilling. An evaluation of the results is reported in /14-2./ Results from air-borne geophysics, measurements of gravity, study of lineaments and field mapping was used to conceptualize the regional geological setting. The tectonic map shows that zones in north-south direction are most frequent. Vertical faulting is common. Zones in east-west direction are older than the north-south zones. One characteristic feature in the area is the diapiric granite intrusions. From the VLF-analyses it is expected that the N-S zones are the most probable water-bearing fractures. The data was also used to a first conceptualization of the target sites Laxemar and Äspö. These evaluations was the basis for siting deep boreholes on either of the sites. Before the percussion drilling programme commenced a regional and local compilation of hydrogeological and ground water chemistry data was compiled. There exist a bedrock-specific capacity. The most pervious units belong to the younger diapires. The least pervious are the greenstones of the area. The

Småland granite, the rock type at the south part of Äspö where the HRL will be sited, has intermediate conductivity. Geohydrological data from construction works in the area has been compiled and typical data of hydraulic conductivity, specific capacity, groundwater table and water chemistry is presented. The preliminary data was used for a first numerical calculation of expected draw-down and inflow to the HRL. The groundwater chemistry has also been interpreted from the survey of regional wells. Conductivity, pH-values, calcium, magnesium, potassium, sodium, iron, manganese, alkalinity, sulfate and nitrate and others was compiled from about 300 wells in the region. Emphasis was placed on analysis of chlorides. The primary objectives of the percussion drilling programme that was carried through on the target sites were to check the hydraulic connectivity in the lineaments, to provide a framework for enhanced prediction at depth and to provide data for the detailed planning of the core drilling programme. Compared to all wells in the region and to the wells in the Simpevarp area the wells show a hydraulic conductivity in the same range as for the gabbro for the whole region. However, the variation is much higher.

The second phase of the site investigation programme has been concentrated to more detailed studies on the island of Äspö. The solid rock has been mapped to the scale of 1:2000. A very detailed study of the bedrock has been performed along cleaned trenches across the island. Fractures have been mapped together with ductile structures to get a four-dimensional description of the rock (three dimensions in space with time). Two reflecting seismic profiles have been recorded in order to identify potential subhorizontal zones. Detailed electric and magnetic mapping of the island was carried through in order to investigate and delineate the local geological setting. The diamond drilling programme commenced late 1987. Three cored holes was drilled at Äspö and one at Laxemar. KAS 02 was drilled to a depth of 924 m in the central part of SE block of Äspö. KAS 03 was drilled in the NW block of Äspö to a depth of 1002 m. KAS 04 was drilled as an inclined borehole, plunge 60°, length 481 m, across the tectonic zone – the “mylonite zone” separating the north and south block of Äspö. KLX 01 was drilled to a depth of 702 m in the central part of a major block in the Laxemar reference area. The borehole diameter varies from about 155 mm at the uppermost 100 metres on the core boreholes, to approximately 76 mm (KLX 01) or 56 mm (KAS 02–04) below 100 metres. This borehole design was found very beneficial for the subsequent hydraulic testing and sampling of ground water chemistry. After drilling was finished geophysical logging was performed. Logging comprised borehole deviation, caliper, sonic, natural gamma ray, single point resistance, self-potential, magnetic susceptibility, normal resistivity, lateral resistivity, temperature, borehole fluid resistivity and radar measurements. The drill cores were mapped carefully, especially with respect to fractures and fracture minerals. The cores have been reconstructed and to obtain

relative orientation. The absolute orientation of the cores was later obtained by TV-logging. The geohydrological investigations in the second phase was directed to hydraulic test in the core holes. Packer tests were performed with section lengths of 3 m and 30 m together with a spinner survey. Transient interference pump tests were as well performed in the boreholes KAS 02 and KAS 03. A study of geohydrological geophysical and geological data was performed in order to assess the hydraulic properties and test relevance of investigation methods. A model of the regional groundwater flow has been set up, based on the regional conceptual model. The model has been used to assess the area of influence from the laboratory. A generic study of the behaviour of saline water in fractured rock simulated by a stochastic continuum was also performed. The drill holes have been used to sample the groundwater. The water has been sampled in three different campaigns: during drilling operation, in connection to the hydraulic tests, and independently from other activities with the equipment used for complete characterization of the deep groundwaters. The chemical composition of groundwater has been compared to the saturation concentration of different minerals. Multivariate analysis have been utilized in order to divide the groundwater samples into different classes.

All data from the pre-investigations will be used to present models of the Äspö site in different scales with respect to geological, geohydrological and chemical conditions. These models will be compared to earlier predictions /14-2/

14.2.3 Construction Phase

Planning for the construction phase is in progress. An evaluation of the alternative access possibilities to 500 m with respect to data acquisition, modelling, cost and operation of the laboratory showed that the tunnel alternative was preferential to the shaft sinking alternative. The tunnel is planned to be a hexagonal geometry as top view perspective. Detailed plans for the surface facilities have been drawn in consultation with the local building authority. Plans needed for application to Water Court have been made.

14.2.4 Operation Phase

A preliminary compilation of potential experiments has been scrutinized. The current planning is directed to towards the following activities:

- site scale tracer tests,
- block scale tracer tests,
- radionuclide migration,
- block scale redox tests,
- methodology for repository development,
- pilot tests, repository system.

The **Site scale tracer tests** will be focussed on transport in the far field and executed to later support the licence application for the final repository site.

The **Block scale tracer tests** will focus on characterization of the near field. The configuration with canisters in rock of low conductivity rock and with a certain distance to closest major flow conduit, will be simulated. The tests will support the licence application for the final repository site.

Radionuclide migration will involve a series of tests performed to determine dissolution and migration of nuclides in situ. Data and models on chemical properties of radionuclides are to a large extent based on experiments in laboratories. It is, however, difficult to obtain natural reducing conditions, natural contents of colloids and undisturbed rock with fissures under relevant stresses in a laboratory. These disadvantages can be avoided by in situ-testing. The experiments will support the license application.

Redox tests to block scale will be performed to demonstrate that the redox capacity is available in the flow paths. Reducing conditions are a prerequisite for a long service life of a copper canister. The test will be used to increase the knowledge on kinetics between groundwater and the fracture minerals.

The detailed planning of **Methods for repository development** and **Pilot tests, repository system** will start when the Swedish concept for the final repository has been selected around 1995.

Methods of repository development will demonstrate how characterization of the near field will be performed during construction of a repository. The interaction between natural and engineered barriers will be a pilot test on the selected repository system.

It is expected that the detailed outline of the activities during Operation will be presented in the R&D-programme that SKB present to the authorities and the government during 1989.

14.2.5 Miscellaneous

Information about the project is frequently presented to the public, the community and to mass media.

14.3 GROUNDWATER MOVEMENTS IN THE ROCK

14.3.1 Overview

A thorough understanding of groundwater movements is essential for a correct safety analysis of a repository. The groundwater flow affect the degradation of engineered barriers, the dissolution of the waste and the transport of solubles in the water.

The relative importance of the parameters that describe flow in the bedrock can be assessed in performance assessments and safety analyses. One of factors that have great importance for assessment of radionu-

slide transport of nonsorbing and sorbing species is the flowrate of water. The flowrate of water in the bedrock is dependent on conductivity, connectivity and the driving forces. The importance of small density contrast for the overall ground water flow distribution has been recognized. The experiences from SFR, from actual groundwater flow measurements in boreholes and analysed in generic models show that even small variations in the salinity of water have a considerable effect on the flow. It has been demonstrated that there often exist an interface between fresh and saline water at depth and that the flow is almost stagnant below the interface.

The conceptualization of the groundwater flow distribution is important for the overall assessment of radionuclide transport, both non-sorbing and sorbing. The hypothesis that groundwater flow occur in essentially independent channels or pathways need thorough studies. Studies of flow distribution in tunnels have supplemented borehole data during the year. A project using radar measurements in conjunction with injection of saline water has started in order to study the potential of using the technique for characterization of the flow distribution.

14.3.2 Fracture Zone Studies at Finnsjön

The rationale for the ongoing fracture zone studies, is to get data and methodology to assess the retention of radionuclides

in fracture zones of the bedrock. The first phase of the fracture study at Finnsjön has been reported earlier /14-3/. The second phase – detailed characterization of the fracture zone – was completed late 1987. A total evaluation the geological, geohydrological and chemical work included in the second phase has been evaluated and will appear in a Technical Report during 1989. The third phase comprise essentially of a series of tracer experiments. All tests are proceeded by predictive modelling.

The first activity in the third phase was the performance and interpretation of a series of hydraulic interference tests and a tracer test. The interference tests were performed by pumping from isolated sections of one borehole and recording the resulting pressure changes in multiple-sections in the borehole. The hydraulic interference test as well as the tracer test documented a very high transmissivity of the subhorizontal Zone 2, particularly in its upper part. A numerical model was used in a series of prediction on more and more detailed data. The final simulation of the interference test show good agreement was achieved between simulated and observed responses from the most distant boreholes. The agreement decreased in the near-region boreholes, a fact attributed to local heterogeneities.

14.3.3 Geostatistical Studies

A pilot study has been performed on the possibilities to predict the hydraulic conductivity and conductive fracture frequency in boreholes using multivariate analysis. Data from core mapping, fracture fillings, tubewave measurements and hydraulic tests from five deep boreholes at the Klipperås study-site was used. About 80–90% of the variation of hydraulic conductivity of an input data set could be explained by utilizing 35–40% of the total information contained in the data set. The highest hydraulic conductivities generally occur in borehole intervals with altered and deformed rock with increased fracture density. The frequency of sub-horizontal fractures in granite generally correlates best to the hydraulic conductivity.

Multivariate analysis has also been used in order to compare radar data with geological, geophysical and hydraulic data. Data from measurements at the study-sites Klipperås, Finnsjön, from the Saltsjö tunnel, Ävrö and Stripa was used as well. The analysis shows a high degree of correlation between highly fractured rock and high radar intensity at all sites. At Klipperås the high fracturing is associated with lithological contacts. The analysis also shows a high degree of correlation for radar intensity and hydraulic conductivity at Stripa and Finnsjön that did not show up from analysis of the other sites. Radar can be seen as an indicator of potentially permeable zones, but is not the ultimate tool, as there exist high hydraulic conductivities not identified by the radar.

A joint project between OWTD,US/DOE and SKB on well test statistic is still in progress. A probabilistic model that describes the distribution of a series of transmissivity measurements has been derived. When the parameters of this model were estimated using maximum likelihood estimators, the resulting estimated distribution generally fit the cumulative histogram of the transmissivity measurements very well. Further, estimates of the mean transmissivity of conductive fractures were reasonable.

14.3.4 Studies in Connection to Construction Works

A test for the predictive capacity of radar measurements has been performed in conjunction with the construction of a full-face drilled tunnel situated in central Stockholm. An interpretation of the radar measurements has been arrived at along a section of the tunnel without access to any other geological, geophysical or hydrological data, except a topographic map of the site. The radar model of the site contained one major feature that was identified as a fracture zone. The intersection of the fracture zone with the tunnel was extrapolated from the radar data and found to be in agreement

with observations in the tunnel. The radar also identified minor features which were of practically no significance with respect to tunnel construction. There is general agreement between the radar model of the site and the geological-tectonic model of the site.

In conjunction with the construction of a tunnel for a hydroelectric power plant in Hyltebruk, southwestern part of Sweden, investigations of a fracture zone have been performed. The aim of the project was to:

- identify and characterize a fracture zone crossing the planned tunnel line,
- test and evaluate methods for underground investigations during tunnel excavation,
- test methods for tracer migration tests, specially tracer detection techniques in tunnels.

A suitable fracture zone was identified using surface geology and geophysics. Eight shallow boreholes were drilled and pumping tests performed, in order to verify the geometry of the zone and describe the geohydrological situation. In some of the boreholes dilution tests also were conducted, giving an estimate of the natural groundwater flow through the zone.

During the tunnel excavation through the zone area, the tunnel front was after every drilling/blasting cycle mapped in detail regarding lithology, rock structure and points of water leakage. Every 20 m, a pilot hole was drilled beside the tunnel front and hydraulic pressure build-up tests were performed. These underground investigations gave practical experience in co-operation between research activities and rock construction works, of great value for the planning of underground documentation in the Hard Rock Laboratory.

For 1989 a tracer migration experiment is planned. Tracers will be injected in the surface boreholes and methods for tracer detection in the tunnel will be tested.

14.3.5 Flow Distribution in a Fracture Zone

As described in the Annual report for 1987 /14-17/ the intention with the experiment is to investigate ground water flow paths in a fracture zone using a combination of borehole radar and saline water injection. The idea is that the saline water which will penetrate parts of the zone will increase the attenuation of the radar signal. The three experimental phases; reference radar measurements, saline water injection and repeated radar measurements during saline water injection, have been performed.

The saline water injection was carried out as a tracer migration test, giving break through data for the surrounding boreholes. For each radar measuring stage both single hole reflexion measurements and crosshole tomography measurements (~7700 rays) were conducted in the seven boreholes penetrating the zone at the Crosshole site in the Stripa Mine. For the comparison of radar results from the two measuring stages

the analysis technique has to be improved regarding the resolution of the radar signal. The evaluation of the experimental results will be carried out during 1989, including the development of a three-dimensional picture of the flow distribution in the fracture zone.

14.3.6 Developments in Modelling

The SKB activities within the HYDROCOIN project has been reported with respect to Level 3 – sensitivity and uncertainty analyses, /14-4/. The calculations have been carried through using the GWHRT code /14-5/. Nine conceptual models for the Fjällveden study-site are compared with respect to head distribution, flow field, flow rates, particle trajectories and recharge. The calculated head distribution and flow pattern for the models differ very little, while the flow rates and residence times vary more significantly, up to a factor 3. Anisotropy of the fracture zones have almost no effect on flow rate, but on the flow pattern skewing the isopotential curves to be more parallel with the main direction of anisotropy. Groundwater recharge as a performance measure of the model at repository depth is of limited use as it primarily reflects the surficial hydrogeological conditions.

Implementation of adjoint sensitivity technique is in progress.

The stochastic continuum concept /14-6/ has been used to study the interface between saline and fresh water. /14-7/ The results from the model include basic test problems, sensitivity studies and a new method to generate random hydraulic conductivities with a given statistical distribution. The model has enhanced understanding flow in crystalline rock, Figure 14-2.

A study has been carried through to determine if and how the borehole data from site investigations can be interpreted with a fracture network model /14-8/. Based on data from Klipperås, it is not possible to directly estimate input data from measurements. However, it was possible to calibrate the network model to measured injection data. The calibration was relatively insensitive to the mean fracture radius and the fracture density, which are important geometric parameters to the model.

14.4 BEDROCK STABILITY

An in-depth analysis of the possible effects of geological processes on a final repository is under way. Essential questions are whether recent movements can lead to new fracturing and whether load changes or rock block movements can decisively alter the geohydrological situation around a final repository.

The objectives are to:

- quantify or set limits on the consequences of earthquakes, glaciation and land uplifts of importance in analyzing the safety of a final repository for spent nuclear fuel,

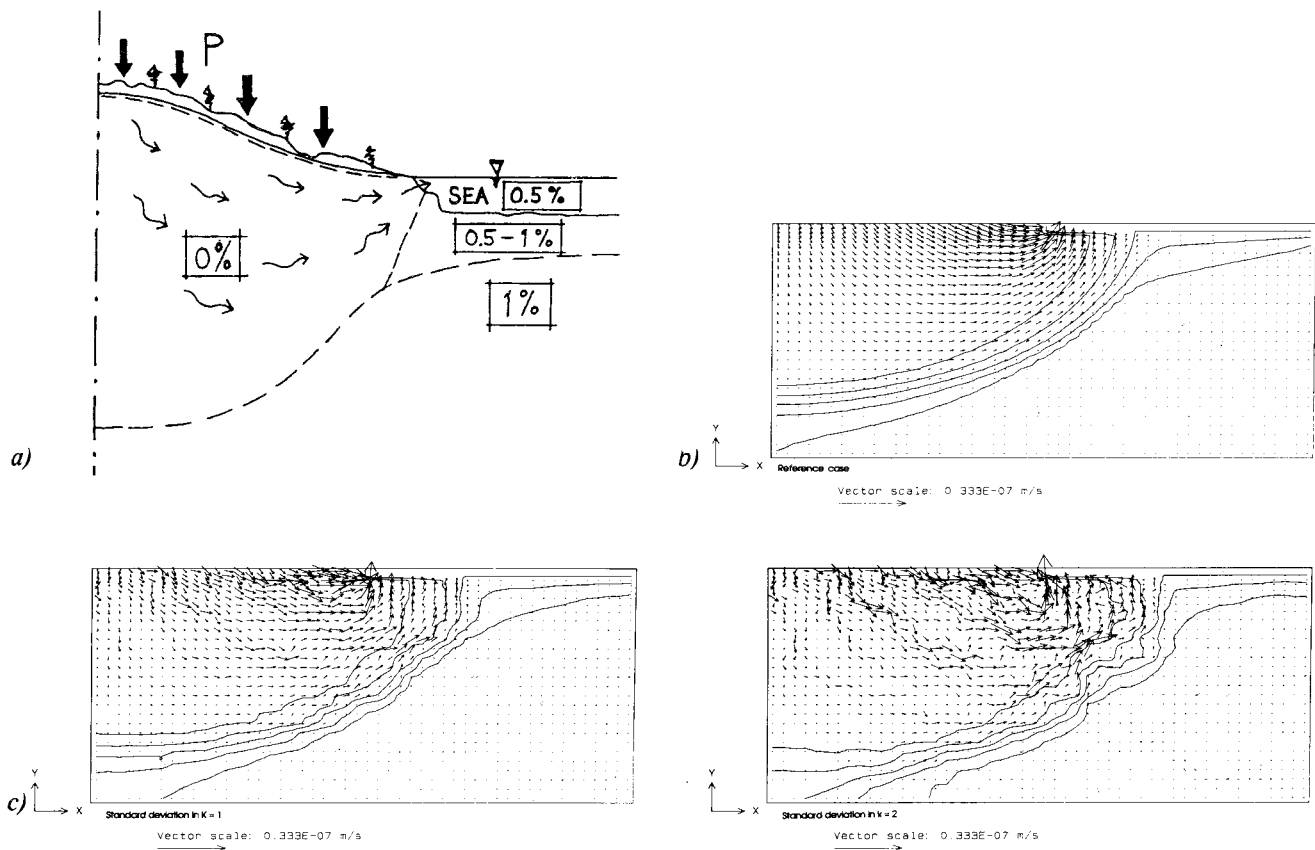

Figure 14-2. Study on interface between fresh and saline water.

- a) Field situation. Salinity in %.
- b) Homogeneous medium
- c) Stochastic continuum. Standard deviation, $\ln K = 1$. K is hydraulic conductivity.
- d) as c) but $\ln K = 2$

– process, evaluate and increase knowledge concerning the geodynamic processes in the Baltic Shield.

Major efforts in the project has been directed to the Lansjärv study and to computer modelling of large scale rock masses to study effects of e.g. glaciation, ice sheet advance, deglaciation, ice sheet retreat and melt-down.

14.4.1 The Lansjärv Study

The Lansjärv fault scarp is supposed to be postglacial e.g. younger than 10 000 years.

A study is outlined to:

- obtain a geological-geophysical basis for an optimal location of detailed studies with deformation measurements, drill holes and excavations. Of special importance is to indicate where new fracturing has occurred in the bedrock,

– obtain an understanding within a broader regional context for where movements and earthquakes occur today.

The major conclusions regarding the tectonics has been reported /14-9/.

- three regional fault systems were identified, two steep NW and N trending and a third NNE trending with gentle ESE dips,
- the steep fault systems have strike-slip generated deformation patterns both in the Precambrian structures and in the surface morphology,
- the post-glacial Lansjärv fault are part of this fault pattern and represent movements mainly on a reactivated, gently dipping zone.

The tectonic interpretation map have utilized digital image-processing techniques for the combined interpretation of magnetic, elevation relief and gravity. So

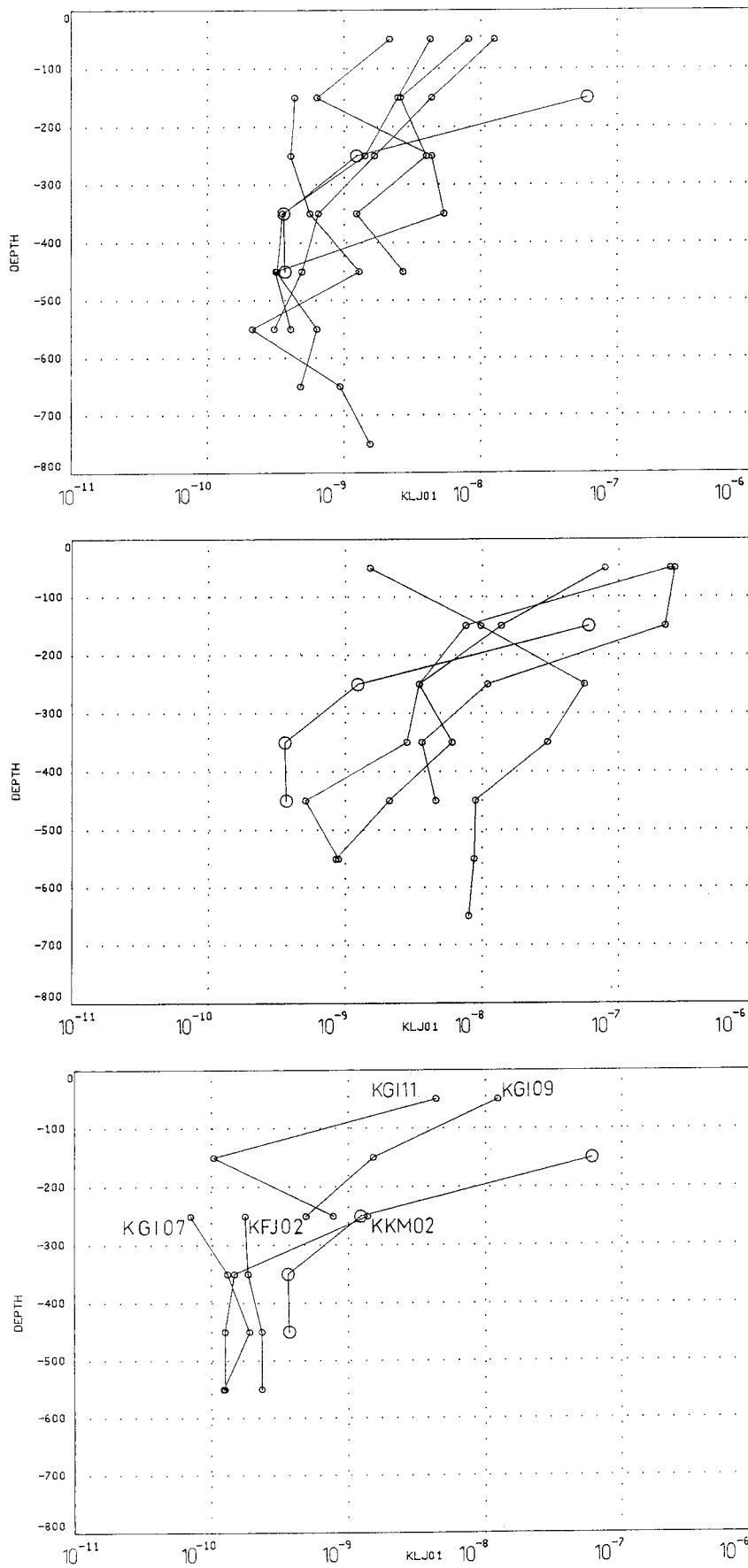

Figure 14-3. Geometric mean of hydraulic conductivity from Lansjärv, Karlshamn (top), Finnsjön (middle) and KBS-3 sites (bottom). Data are calculated in 100 m vertical depth interval. Lansjärv (KLJ01) have larger circles.

far, no new post-glacial fracturing of the bedrock was identified.

By trenching across the fault scarps it has been possible to date fault movements relative to the Quaternary stratigraphy /14-10/. It is concluded that the post-glacial faults in the Lansjärv area developed as single-event movements shortly after the deglaciation about 9000 years ago. The scarps are developed in strongly fractured and chemically weathered zones of presumed pre-Quaternary age. The results from the trenches suggest, at least at the surface that the faults are reverse and dipping between $40 - 50^\circ$ and the vertical.

The mobile network for detecting seismic activity has registered a few events during the 1987 period /14-11/. For the 1988 campaign some of the stations were relocated. 28 events were detected. Plausible focal styles have been derived for four events, showing a variety of faulting styles. Many events are located at depths of 8–10 km.

Up to Feb 1989 more than 90 events were detected by the permanent network with signals at 3 or more stations. The magnitudes were in the range M_L 0.1 – 3.6. The released stresses have the horizontal principal compression in the NW-SE quadrant. The dominating type of fault movements is strike-slip at subvertical planes.

Based on the results and analysis of geophysical measurements and tectonic interpretation a site for core drilling was suggested. Three percussion boreholes and a 500 m cored hole were drilled. As the cored hole collapsed at a depth of 148 m, a casing was set down to this depth. The hole was logged with several geophysical methods. Core mapping shows predominantly red-gray granite as the basic rock type. Pegmatites and aplites occur as dykes and veins. Tectonic breccia occurs in some sections of the borehole. The upper part of the hole 32 – 300 m is very fractured, while the lower section is less fractured. Samples of groundwater chemistry at depths of 150 m and 237 m show that the Lansjärv water belongs to the group of intermediate non-saline granitic groundwaters. Eh (redoxpotential) monitoring as well as presence of detectable amounts of ferrous iron indicate the reducing character of the water. A mineralogical and geochemical study has been performed of fracture-infillings in the drillcore in order to identify evidences that may support recent reactivation and to determine whether low temperature rock/water reactions have contributed to changes in the fracture mineralogy and chemistry. Of particular interest to this study is the variation of U, Th, REE (Rare Earth Elements) from the fracture edges into the wall rock as well as their variation with depth. The study show that the rock has been exposed to extensive hydrothermal activity especially pronounced in the upper 300 m of the drillcore. Subsequent to hydrothermal period(s) low temperature groundwaters have caused redistribution of elements as well as minerals e.g the dissolution of calcite and the leaching of U and light REE in the flow paths in the upper part of the borehole. Measurements

of rock stresses by means of hydraulic fracturing has been carried through. The minimum horizontal stress especially near the bottom of the hole is exceptionally low, close to 6 MPa, among the bulk of data obtained elsewhere in Sweden. Maximum horizontal stress values are more scattered, but is in general in the same order as the vertical stress. The direction of the maximum horizontal stress is depth dependent. At 300 m the direction is NW-SE. However, it rotates rapidly and steadily with depth and at the bottom of the hole it has turned to ENE-WSW. This re-direction of stresses with depth is unusual. Hydrogeological testings was carried through in the hole, including measurements of hydraulic conductivity and observations of groundwater pressures. The hydraulic conductivity decreases slightly with depth. The highest values ($> 1 \cdot 10^{-6}$ m/s) are obtained in the depth interval where the fracture frequency is highest and where the hole is interpreted to intersect the post-glacial fault. There is no obvious correlation between hydraulic conductivity, fracture frequency, rock type, rock stress or infillings. Compared to other study-sites, see Figure 14-3, the conductivity show no clear anomaly, even though the rock may have experienced a $M_L = 7$ earthquake. Measurements of groundwater levels, however, show some peculiarities.

The groundwater level is approximately 70 m below surface in the percussion hole KLJ 01 and there is a relatively large vertical gradient through the length of the borehole. Numerical modelling was done in order to study some aspects of the effects of fracture zone geometry on groundwater flow conditions. The modelling show that the existence of a continuous fracture zone with an inclination of 15° does not explain observed hydraulic data. A steeper inclination of the fracture zone give a better fit with data. Another possibility is several subhorizontal parallel fracture zones.

It is anticipated that the Lansjärv study will be concluded during 1989 and that the study later can be used for a comparative analysis of the tectonics in the South East of Sweden where no post-glacial scarps have been identified and where seismic activity is very uncommon.

14.4.2 Computer Modelling of the Rock Mass

Two-dimensional modelling have been used to study the potential influence of glaciers on the rock mass at depth.

The first part of the modelling project has been aimed at attempts to validate the numerical codes used. The Colorado School of Mines block tests have been used for checking the performance of the codes /14-12,13/. Using the finite difference code MUDEC, the rock is essentially treated as a discontinuum. The modelled stresses indicate similar features compared to those measured in the CSM block i.e rotations from blocks to block when crossing a joint. The ranges of values for deformations are in agreement with the measured. Joint apertures was modelled to the range 35 to 50 μm compared to the measured values of 27 to 55 μm . Using the

finite element code HNFEMP the rock is essentially treated as a continuum. There is a fair agreement in the orientations and magnitudes of displacement vectors and direction of principal horizontal stress, see Figure 14-4.

The effect of glaciation and deglaciation has been studied as well. Six loading cases were modelled for a 44 km rock mass with three different fault set geometries. The results from one calculation using MUDEC and Barton-Bandis non-linear joint model show inter-block displacements in the order of 5 to 10 cm for the assumed material properties. The work is still in progress.

14.4.3 Studies in Southern Sweden

The permanent seismic network that is in operation in the South East of Sweden show still a low seismicity. 22 events have been detected during April 1 1987 to Nov 30 1988. One earthquake $M_L = 1$ occurred within the central part of the network.

14.4.4 Miscellaneous

URL - CHARACTERIZATION OF THE 240 LEVEL

AECL and SKB signed in April 1987 an agreement on cooperation for characterization of the 245 Level in the Underground Research Laboratory situated in a granitic batholite in Manitoba, Canada. The agreement expires 1990. SKB regularly attach staff or designated representatives to follow and participate in the work. The work on rock stress measurements have been evaluated. /14-14 /. Present assignment has been directed to a cooperative effort for a re-evaluation of the so called Room 209 Excavation Response Experiment. The work performed has addressed discrepancies between calculated and in-situ measured hydraulic response as a part of a post-excavation analyses of the test. Already existing hydraulic conceptual models were revised and any available information was included in the new model. By altering the permeability in the floor and along the walls and roof of the periphery of the tunnel, a better correspondence between calculated and

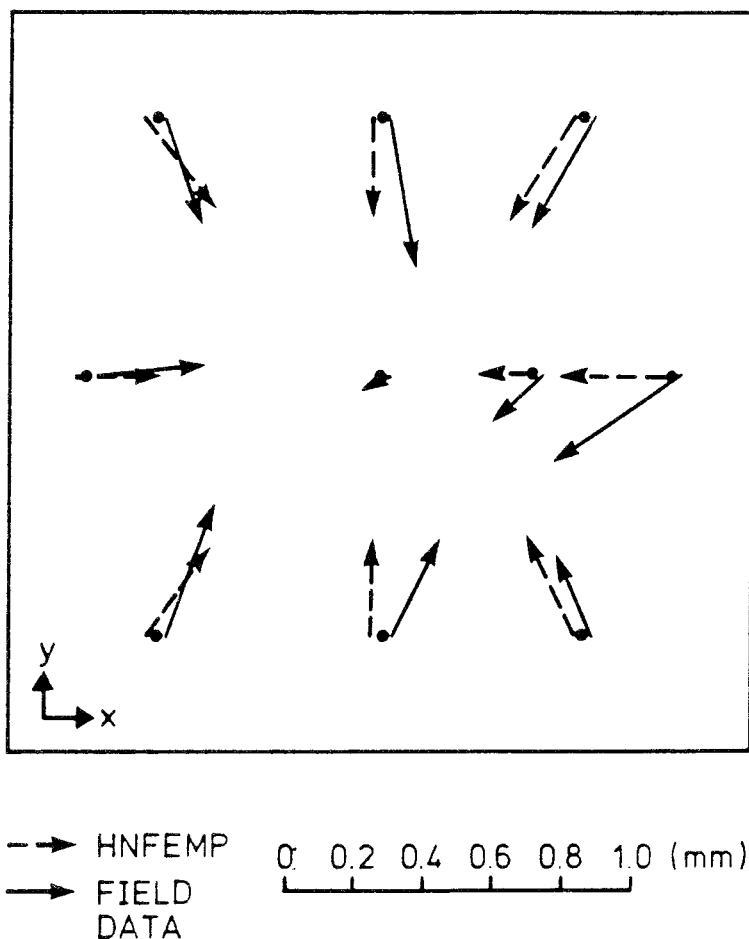

Figure 14-4. Some results from verification of the HNFEMP-code. Displacement vectors at peak load from field tests and modelling /14-13/.

A) E-W loading B) Uni-axial N-S loading C) Bi-axial loading.

measured drawdown was obtained. The same also applied for measured inflow in quantity, though not for the actual distribution of inflow. As causes for the skin around the tunnel, partial unsaturation, propulsion of debris into fractures and effects of blasting was deemed to be of importance.

KLIPPERÅS

The regional modelling exercise has been focused on the effect of heterogeneity and depth dependence for the hydraulic conductivity on the boundary conditions /14-15/. The average flux values at a depth of 500 m is in the order of 0.3 l/m^2 , year. The sub-regional 500 km^3 3D model was quite insensitive to the lateral boundary conditions applied.

TECTONIC UNITS

Morphology, bedrock geology and the tectonics of Sweden have been compiled /14-16/. Sweden is subdivided into three terrain types, South-East Sweden Terrain, Norrland Terrain and Caledonian Terrain.

The tectonic structures have been evaluated from geological and lineament maps. The new lineament map based on relief shows acceptable correlation with lineaments based on Landsat images, when large tectonic elements, $> 50 \text{ km}$, are compared in southern Sweden. The correlation is worse for northern Sweden.

A new interpretation is presented of lineaments regarding location, direction and lengths of large lineaments. Based on the compilations, Sweden is divided into tectonic units.

14.5 DEVELOPMENTS OF INSTRUMENTS AND METHODS

During 1988 an extensive site characterization program has been performed during the preinvestigation stage of the Hard Rock Laboratory. Beside methods normally used for the characterization of a rock formation a number of new borehole testing methods have been practiced for the first time. These new methods have been possible since the telescope drilling technique – 165 mm diameter in the uppermost 100 m of a deep 56 mm borehole – were introduced last year /14-17/. Other improvements in field investigation techniques have been conducted separately or in other projects, such as the international Stripa Project.

14.5.1 Hydraulic Testing Equipments

The telescope borehole design has made it possible for ordinary electrically submersible pumps to be used for test pumping. A short time after drilling a combined test pumping and cleaning-up pumping has been conducted, in order to pump up the remaining drilling fluid

and drilling debris, but also to calculate the total transmissivity of the borehole-penetrated formation.

In combination with this test pumping, flow-meter logging were carried out along the borehole below the pump level. The cumulative flow up to the pump along the hole were recorded, thus indicating all waterbearing fractures or fracture zones, see Figure 14-5.

Water injection tests have been conducted as normal standard. Besides that, pumping tests from packed-off borehole sections have been performed using a modified Pipe String Equipment. By building a steel housing around a submersible pump, and connect the pumping device to a straddle packer tool via a pipe-string, strictly controlled pump tests could be performed, see Figure 14-6. By means of a new flow meter and regulation unit, constant flow rate were automatically adjusted. In order to hurry up the mobilization time for the Pipe String Equipment all components, including the hoisting rig and data acquisition system, were installed in a mobile container.

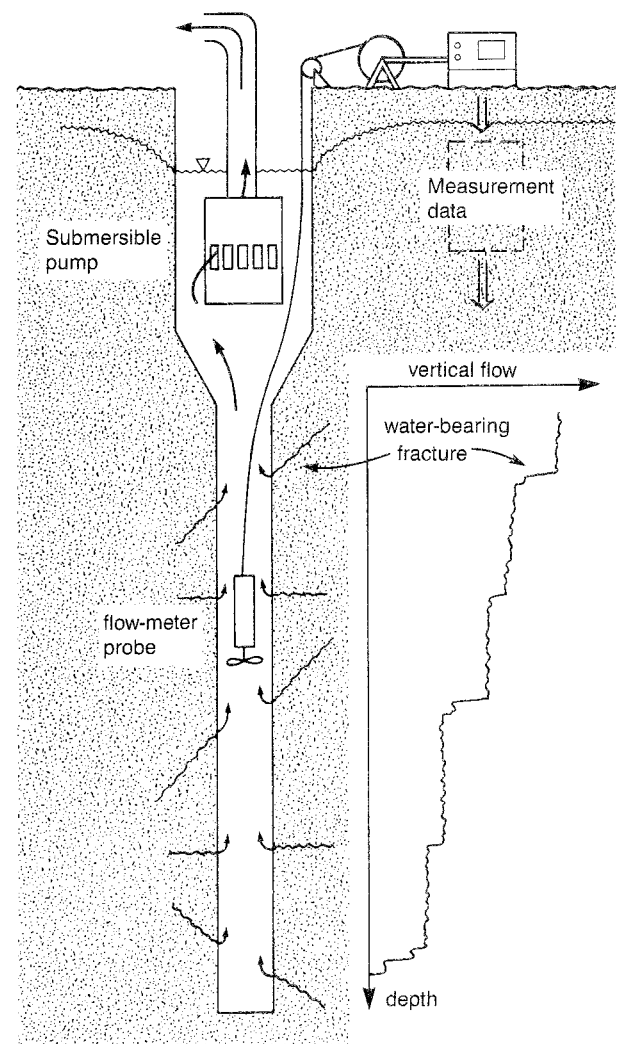

Figure 14-5. Flow-meter logging during pumping, indicating waterbearing fractures or fracture zones.

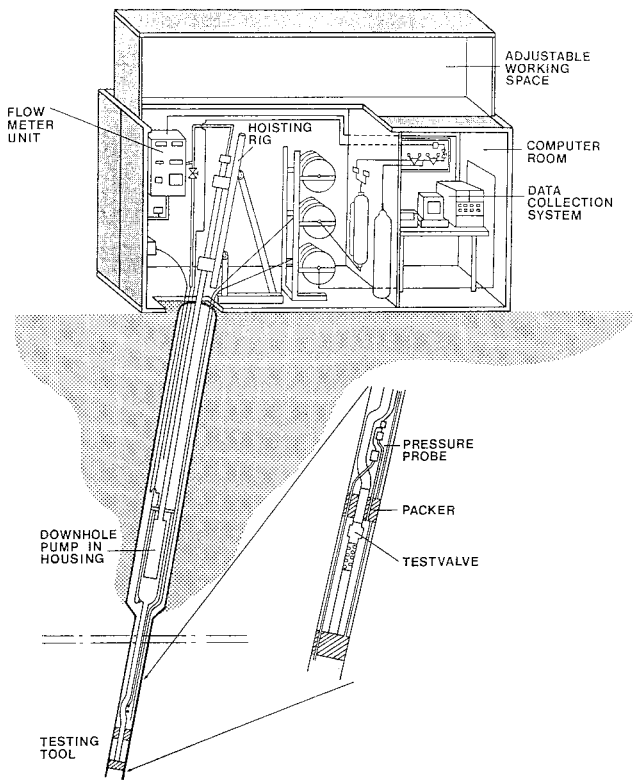

Figure 14-6. Pipe String Equipment – test arrangement for pumping from packed-off borehole sections.

14.5.2 Multilevel Piezometric Monitoring

In 1987 a new slimhole packer construction with several pressure tubings was developed. Methods for multi-packer borehole installations in normal 56 mm boreholes and in telescope boreholes were described in SKB Annual Report 1987 /14-17/. The installation method for telescope boreholes has been extensively used in the Hard Rock Laboratory project. The boreholes, 450–1000 m deep, have normally been divided in six packed-off sections. For continuous monitoring of the piezometric head in the sections each waterlevel standpipe are separately equipped with a transducer, connected to a datalogger. The datalogger, Borre MDL, which has been specially designed for this purpose is composed by

two main parts; surface unit including multiplexer and battery, and borehole unit including all sensitive electronics such as A/D converter and memory (constant temperature in the borehole). The fluid conductivity in two of the isolated borehole sections are recorded by specially designed sensors, in order to registrate changes in the salt water interface level. A flexible measuring program is developed, easily installed and changed by means of a laptop computer, also used for the transfer of data to a graphic computer.

14.5.3 Hydrofracturing Equipment

The development of a new equipment for rock stress measurement with the method of hydraulic fracturing is completed. Mounted on a truck the system is self-supporting and easy to mobilize. The down-hole tool with high-pressure straddle packers and pressure transducers are easily lowered in the hole on an umbilical hose and a hoisting drum. The umbilical hose includes high-pressure hoses and signal cables. The orientation of the induced fractures are detected by an orientation tool with impression packer, single-shot camera and borehole compass. Measurements at depths of 1000 m in 56 mm boreholes or larger can be performed.

14.5.4 Borehole Radar

As an extension of the existing borehole radar system a directional antenna has been constructed. The development work is a part of the international Stripa Project. The directional antenna has two current loops placed at right angles to each others. The antenna rotation is digitally synthesized from several measurements. The time for measurement has increased since at each point four signals are registered rather than one. This increase is compensated by the fact that an electric dipole measurement is obtained simultaneously with the directional components. Beside the novel directional antenna a directional indicator to measure the orientation of the antenna probe in the borehole and a fourth optical fibre communicating have been constructed. The incorporation of new amplifiers and a new sampler to the radar system have also improved the measuring accuracy of the system. Using the directional antenna, the orientation of a fracture zone or other detectable structure can be defined with an accuracy of $\pm 5^\circ$.

15 BIOSPHERE

15.1 GENERAL

As during the last years the biosphere studies in 1988 have been concentrated on the transfer of radionuclides from the deep groundwater to man. The investigations have focused on the variability of the transfer of radionuclides from ground water to man due to normal change in the primary recipient of the ground water inflow and on the characteristics of sediments in inflow areas of lakes as compared to other sediments.

15.2 NATURAL AGEING OF LAKE ECOSYSTEMS

The natural changes occurring when the landrise is causing a brackish water estuaries is separated from the sea and slowly turn over to lakes and finally to agricultural land has been studied in two lake/estuary systems in Sweden. The earlier results has been reported in four Technical Reports /15-1 – 15-4. The final part of that study was to evaluate the effect of that variability when modelling the transport of released radionuclides through the biosphere to man. This has been reported in SKB TR 88-31, Long-term dynamics of a lake ecosystem and the implications for radiation exposure.

As expected the transfer from ground water to man is strongly influenced by the primary recipient. Depending on the radionuclide the transfer factor will change when a lake is formed, as the lake will get smaller by eutrophication, as the sediments are converted into agricultural land etc. Some nuclides like cesium show a maximum transfer factor when the lake can support a sustained fish population, others like technetium and iodine when producing cereals or letting cattle graze at the shore sediments. The variability with recipient change seems at maximum to be around one order of magnitude.

At large, a typical biosphere as used in the KBS reports and in the SFR licencing, containing a small farmhouse using a well for water consumption, a lake for fishing and irrigation and having both livestock and

cereal production, seems to give a reasonable upper estimate of the doses to a hypothetical critical group.

In future comparisons between various repository concepts SKB intends to use such a standardized biosphere in order to simplify the comparison and not to confuse the evaluation with irrelevant uncertainties.

15.3 CHARACTERISTICS OF SEDIMENTS IN INFLOW AREAS

All the release pathways of radionuclides from a repository to man assume that the deep groundwater will reach the biosphere either in a well or in a groundwater outflow area. The outflow is often to a lake or a stream. Should a substantial groundwater outflow take place in a lake, it will probably influence the sedimentation rate, the chemical composition of the sediments and the biologic activity in the local area. These are all factors that can be of importance to the transfer of radionuclides to man.

Two lakes have been selected for the experimental studies. The major constituents, some heavy metals (As, Cr, Co, Zn) and the uranium content of both sediments and the sedimental pore water are measured. Samples are taken at different depths in areas affected by the inflow and "normal" sediments. In the solid phase rare earth elements and thorium are also measured and grain size and organic fraction is determined.

The study is expected to be reported in 1990.

15.4 CHERNOBYL FALLOUT

In order to utilize the Chernobyl fallout for validation of nuclide migration models in the shallow groundwaters and the upper soil layer, samples have been collected and measurements have been made in two Swedish areas since 1986. SKB intends to continue this work and initiate an evaluation effort at a suitable time.

16 CHEMISTRY

The chemistry programme has been divided into four major parts:

- geochemistry,
- radionuclide chemistry,
- chemical transport,
- validation of transport models.

The chemistry programme was generally discussed during a seminar in August 1988. The notes from the meeting resulted in a state of the art report on chemical aspects of a nuclear waste repository.

16.1 GEOCHEMISTRY

16.1.1 Groundwater Analyses

Groundwater samples were collected from newly drilled shallow percussion boreholes on Laxemar, Ävrö and Äspö in the pre-investigation stage for the siting of the Hard Rock Laboratory. Water samples were also collected from the surfaces: ditches, streams, lakes etc.

The evaluation of the results /16-1/ indicated that the surface waters were a pure mixing between the precipitation and the sea water, whereas the shallow groundwater had a composition which is affected by the interaction with minerals in the rock, see Figure 16-1.

The rapid sampling of the newly drilled holes was possible due to the construction of a portable air lift pumping system, /16-1/. The sampling could thus be completed within one day after finishing the drilling. As expected this turned out to give representative water samples, free from contamination. High salinity of the water indicated that the water in the bedrock was stagnant.

During 1988 the groundwater sampling was concentrated to three deep core drilled holes, two on Äspö and one at Laxemar. The sampling and analyses were made by the mobile field equipment which is normally used for the chemical characterization of the groundwater. The results are in good agreement with the predictions which were made on the basis of the results from the percussion boreholes /16-2/.

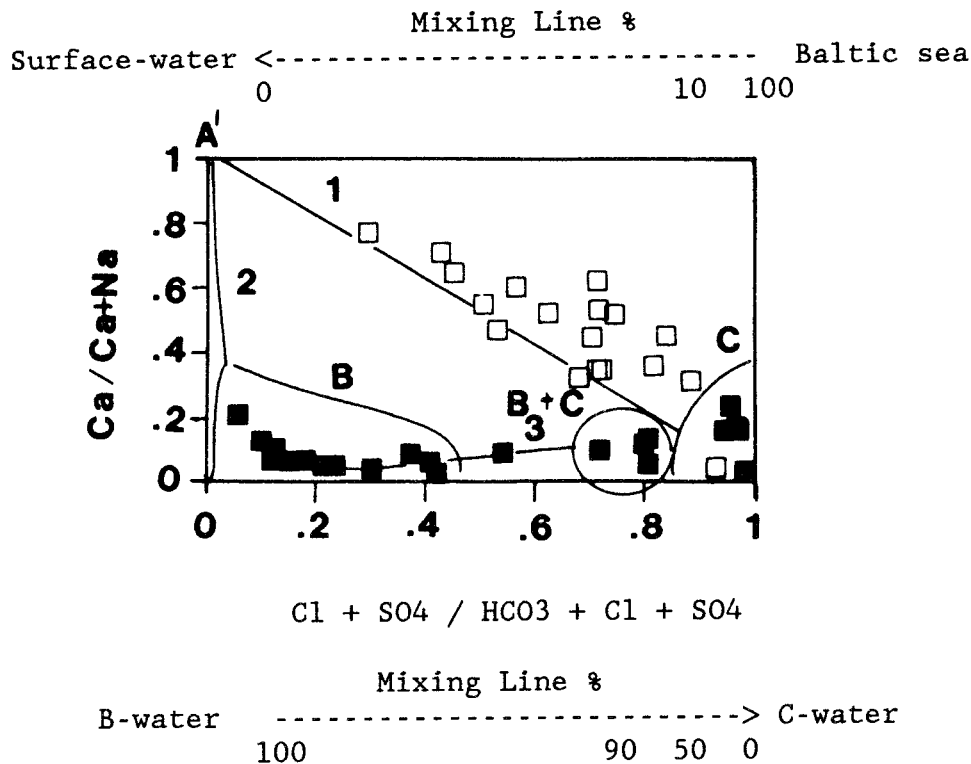

Figure 16-1. Filled squares represent shallow waters from Laxemar, Äspö and Ävrö, plotted in molalities on a modified piper diagram. Open squares are surface waters from the area. Number 1 represents the mixing between surface water and Baltic sea water spray. Number 2 and 3 represent three different evolution lines for the water of B, C and B + C-types. The calculated mixing lines in % for the different water types are presented.

Table 16-1. Concentrations of elements present in borehole KLX 01, at 272 meter. Total and hollow-fiber fractionated samples. (Results obtained at the field laboratory)

Element	Total	M _w < 10 ⁴ Dalton sample 1/sample 2	M _w < 10 ³ Dalton sample 1/sample 2
Fe(tot) mg/l	0.109	0.095/0.095	0.102/0.097
Fe ²⁺ mg/l	0.109	0.090/0.089	0.096/0.097
Mn ²⁺ mg/l	0.20	0.22/0.22	0.25/0.25
Ca ²⁺ mg/l	244	248/248	248/248
Mg ²⁺ mg/l	26	26/26	27/26
Na ⁺ mg/l	1040	1020/1020	963/954
K ⁺ mg/l	5.9	5.6/5.9	5.7/5.6
HCO ₃ ⁻ mg/l	85	81/82	80/80
SO ₄ ²⁻ mg/l	49	65/65*	42/42
Br ⁻ mg/l	7.8	9.1/10.0*	7.5/7.6
SiO ₂ -Si mg/l	5.7	5.4/5.3	5.4/5.5

* The sample volumes were small and the samples were stored overnight prior to analysis.

Hollow fibre fractionated samples have been collected in conjunction with the sampling in the KLX 01 borehole. In Table 16-1 the results obtained at the sampling of the 272 m section are presented.

16.1.2 Fracture Mineral Studies

A drillcore sample, representing an alteration profile extending from a single, open conducting fracture, out into a host granite, has been examined. In addition to detailed mineralogical studies, the uranium decay series (whole-rock samples), together with $\delta^{18}\text{O}$, δD and Fe(II)/Fe(III) ratios (biotite/chlorite separates), have been analysed. Some measurements of rock porosity and diffusivity have also been carried out on intact samples.

The results show that most of the observed mineralogical, chemical and isotopic trends extending from the fracture face into the host bedrock reflect at least one oxidising hydrothermal event in the geological history of the region, i.e. postmagmatic activity of the Lina granite intrusions during the Svecokarelian epoch some 1800 Ma. The hydrothermal alteration has affected a zone of 2–3 cm from the fracture face resulting in higher Fe(II)/Fe(III) ratios and increased $\delta^{18}\text{O}$ values. The hydrothermal activity is also responsible for increased uranium and thorium contents close to the fracture. The uranium decay series data, and to some extent the δD data, also indicate a more recent chemical change within a narrow zone 1 cm from the fracture face, at least over the last 1 Ma as determined by the half-lives of ²³⁸U and ²³⁴U. These changes are considered to be due to low-temperature rock/water interactions and have been superimposed on the earlier hydrothermal trends. The uranium decay series data suggest that such leaching processes, although more accentuated at the fracture edge, extend throughout the studied core length, whereupon ²³⁴U has been removed from the rock matrix. No obvious changes in rock porosity and dif-

fusivity occur between the relatively fresh core and the altered zone adjacent to the fracture face. /16-3/

16.2 RADIONUCLIDE CHEMISTRY

16.2.1 Solubility and Speciation

Laboratory experiments have been performed in order to determine the chemical thermodynamic constants which control the solubility and speciation (inorganic) of uranium and thorium in groundwater. Investigation of phosphate complexes have been initiated.

Liquid extraction technique is being tested as a method to determine the hydrolysis complexes of uranium and plutonium.

International cooperation is an important ingredient in the effort to determine thermodynamic constants. For neptunium and plutonium the cooperation with the French CEA have been very fruitful /16-4/. Hydrolysis complexes of uranium(IV) have been investigated with laser spectroscopy (TLS) in cooperation with the Ispra-laboratory in Varese, Italy /16-5/.

A chemical thermodynamic database on uranium, SKBU1, have been collected for use by the geochemical codes EQ3/6. The database have been validated by application on independent experimental results /16-6/. The EQ3/6 geochemical codes are in operation on the SKB VAX-computer.

SKB is supporting the participation of Swedish experts in the development of a chemical database, TDB, for safety relevant radionuclides. This is managed by OECD-NEA. The work on the uranium database is most advanced. SKB is also participating in the CHEMVAL project to validate geochemical codes used for evaluation of radionuclide release and transport. CHEMVAL is organized by CEC.

16.2.2 Organic Complexes, Colloids and Microbes

Dissolved organic material have been gathered from deep groundwater. The material have been purified and humic- and fulvic acids isolated. Most of the organic material consists of fulvic acids which are characterized

and used in experiments on radionuclide retention. Carbon-14 analyses have been made of the fulvic acids. This is a method to determine carbon-14 ages of groundwater and an alternative to the conventional analyses of carbon-14 in dissolved carbonates, see Table 16-2.

Table 16-2. Analyses of fulvic acids isolated from surface water in Bersbo and deep groundwaters from the study sites.

Site		Bersbo	Fjällveden	Finnsjön	Gideå
Depth	(m)	Surface Water	409	232	107
INORGANIC GROUNDWATER CHEMISTRY					
pH		5.3	7.5	7.7	8.8
Eh (mV)		–	-110	-270	-10
HCO ₃ ⁻	(mg/l)	5.5	170	260	161
SO ₄ ²⁻	(mg/l)	36	0.2	140	0.8
F ⁻	(mg/l)	<0.1	0.7	2.3	2.6
Cl ⁻	(mg/l)	7.2	7	1500	4.4
Na ⁺	(mg/l)	5.8	32	650	49
Ca ²⁺	(mg/l)	8.3	21	320	10
K ⁺	(mg/l)	1.8	2.5	8.7	2.2
Mg ²⁺	(mg/l)	8.6	0.4	40	2.6
Age ¹⁴ C-carbonate	(years)	–	4235	8090	6450
CHEMISTRY OF FULVIC ACIDS					
Molecular-Weight M _w		2650	1700	2650	1600
C	(%)	52.5	50.8	53.0	53.7
H	(%)	3.6	3.9	3.8	4.4
N	(%)	1.1	1.7	0.9	0.5
O	(%)	38.8	39.7	36.2	37.5
S	(%)	1.0	0.8	1.1	0.5
Ashes	(%)	3.0	3.1	5.0	3.4
Aqueous acid capacity	(meq/g)	4.65	5.14	4.98	5.42
Non-aqueous acid capacity	(meq/g)				
COOH		4.78	5.56	4.16	5.33
OH		1.35	2.53	0.83	1.05
total		6.13	8.09	4.99	6.38
Extra acidity due to chelation	(%)				
Cu ²⁺		65–70	40–45	45–50	45–50
La ³⁺		23–30		38–40	
Age ¹⁴ C-organic	(years)	–	1270	4610	5250

A model for calculating the bonding of ions to humic- and fulvic acids has been developed at the New York University in Buffalo /16-7/. Humic- and fulvic acids are according to that model treated as polyelectrolytes.

Inorganic particles in the groundwater are being regularly analysed. Investigations of their ability to carry radionuclides have been initiated.

Analysis of natural groundwater colloids and their ability to transport radionuclides is also a part of the natural analogue studies, see Chapter 19.

Microbes in deep groundwater have been analysed. Samples have been taken in-situ with a sond. Deep groundwaters have been found to contain microbes in quantities of between 10^5 and 10^6 bacteria per ml /16-8/. The nature of these bacteria is being analysed.

Microbes in groundwater and on minerals are also being investigated within the frame of the Poços de Caldas natural analogue study, see Chapter 19.

16.2.3 Sorption and Diffusion

Diffusion into the connected micropore system (matrix diffusion) of granitic rock have been measured with radionuclides of cesium, strontium, technetium, iodine, americium, plutonium and neptunium. The rock samples were taken from drillcores into granitic rock in Finnsjön, Stripa and Studsvik. The measured diffusivity,

D_a , varied between about 10^{-13} to 10^{-15} m^2/s depending on nuclide. The interaction of the different radionuclides with different bulk rock minerals and fracture filling minerals were studied as well.

Diffusion experiments have been performed on sand-bentonite mixtures. This material have been suggested as a backfill for tunnels and shafts of a repository.

Diffusion experiments are also being performed on bentonite with "getters" i.e. additives with an expected favourable effect on radionuclide retention.

Surface complexation theory is being used in an attempt to model sorption and diffusion of radionuclides on mineral surfaces. The method have been successfully applied to sorption on pure oxides. Experiments are being made to see if it is possible to include other mineral surfaces.

16.2.4 Radiolysis

Experiments and theoretical calculations have been made of the radiolytical production of hydrogen peroxide by alfa radiolysis of simulated groundwater /16-9/. Fair agreement between experimental and calculated values was obtained.

Experiments have also been performed on the migration of a redoxfront in compacted bentonite as a result of alpha radiolysis /16-10/, see Figure 16-2. A relatively

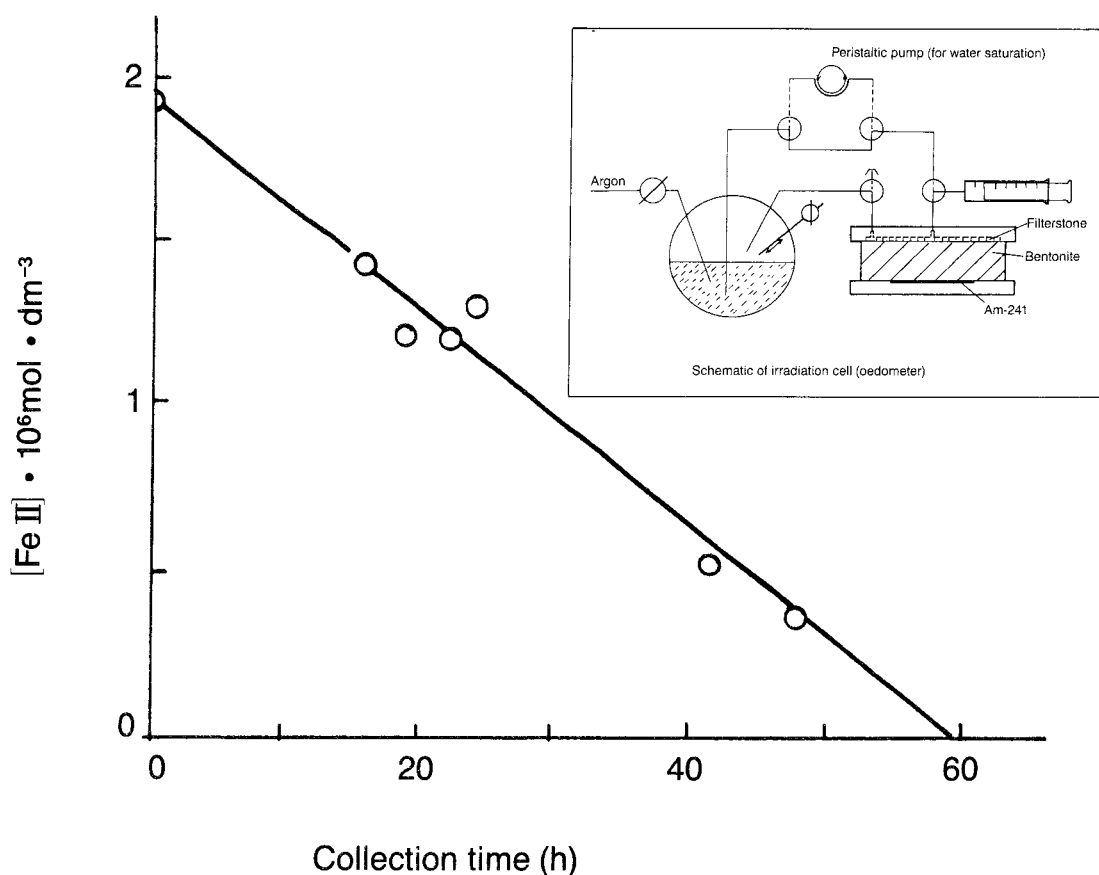

Figure 16-2. Consumption of ferrous iron by oxidants generated by alpha radiolysis of wet compacted bentonite.

good agreement was obtained with calculated values. It was found that only part of the divalent iron in bentonite was accessible for reaction with the radiolytically produced oxidants.

16.2.5 Concrete

Laboratory experiments are being performed with diffusion in concrete and diffusion from concrete to bentonite. This is a general approach to evaluate the benefit and consequences of using concrete as a construction or backfill material in a repository.

A theoretical study have been made on the potential chemical interaction between concrete and granitic rock at high temperature /16-11/. This study was aimed at the evaluation of the consequences of using concrete in the WP Cave concept for disposal of spent fuel.

16.3 CHEMICAL TRANSPORT

The distribution of water flow between different water conducting fractures and the distribution of flow in the fractures have a strong impact on the dispersal of radionuclides in the groundwater. The existence of preferred flow paths, "channels" may cause a reduction in retention due to a reduction in accessible contact surface on the rock. A two-dimensional statistical model have been used to simulate a water conducting fracture with uneven flow /16-12/. Water flow and transport of dissolved species in the fracture have been calculated for different realizations of the model, see Figure 16-3.

Coupled models geochemistry/transport have been tested and applied. The computer code CHEMTRN have been applied on the chemical interaction bentonite/concrete and the code THCC have been tested on the movement of a redox front in a uranium mine /16-13, 16-14/. Both CHEMTRN (Chemical Transport) and THCC (Thermal Hydrological Chemical Coupling) have been developed at Lawrence Berkeley Laboratory, USA. THCC is an offspring of CHEMTRN and has been developed to incorporate variable temperatures and redox reactions.

Coupled models transport/geochemistry are being applied to the observed redox fronts in the uranium mine in Poços de Caldas. The investigation of the uranium mine is part of the Poços de Caldas Project, see Chapter 19.

16.4 VALIDATION OF TRANSPORT MODELS

16.4.1 Laboratory Experiments

Laboratory migration experiments are performed with overcored water conducting fractures in granitic rock. The cores are usually taken from the Stripa mine. The results of the tests are used to validate models of water

flow in fractures and transport of dissolved radionuclides. Data from earlier experiments have been compiled as a test case for the international INTRAVAL study managed by SKI.

A system, isolated from the oxygen in the atmosphere, have been developed around the equipment for the laboratory migration experiments. The aim is to simulate the transport of redox sensitive radionuclides in a deep groundwater/rock environment i.e. reducing conditions. Experiments have been performed with technetium in this set up /16-15/, see Figure 16-4.

16.4.2 In-situ Tests

Tracer tests with conservative tracers are being carried out in granitic rock in the Stripa mine within the frame of the international OECD-NEA project, see Chapter 18. The migration experiments have been carried out over distances between about 1–50 m. Longer distances of transport have been observed.

One important aim for later investigations in Stripa have been to trace the distribution of water flow over the fracture surfaces. Radar have been successfully used for that purpose, see Section 14.2.4.

A series of experiment have also been performed in Stripa in order to validate the existence and diffusive properties of a connected pore system in low conductive rock /16-16/. To ensure an undisturbed intact portion of the rock, drillholes were made well away from the tunnel (20 m). Tracer injections were made in thin boreholes, again with the aim not to disturb the rock (see Figure 16-4). A mixture of three non-sorbing tracers were injected: Uranine, chromium-EDTA and iodide. The injections were made under slight overpressure and went on for 3 months, 6 months and 3.5 years. Sampling has been made by overcoring the injection holes. Drillcores were also taken further out from the injection holes. The rock samples were analyzed for their content of tracers. The results show that all three tracers have migrated through a disturbed zone near an injection hole, through fracture filling minerals and further into the undisturbed rock, see Figure 16-5.

Tracer tests are also being carried out in a sub-horizontal fracture zone in Finnsjön. The zone is about 100 m thick and situated at a depth varying between 100 and 300 m. A radially converging tracer experiment have been carried out /16-17/. Injections were made in three boreholes at a distance of 150 m from a central pumping hole. Three packed off sections in each borehole were used for separate injections. A total of 11 different non-sorbing tracers were injected. The results of the experiment and all background information are offered as a test case to the INTRAVAL project.

Methods for performing tracer tests from a fracture zone to an intersecting tunnel are being developed in connection with the field tests in Hylte, see Section 14.3.4.

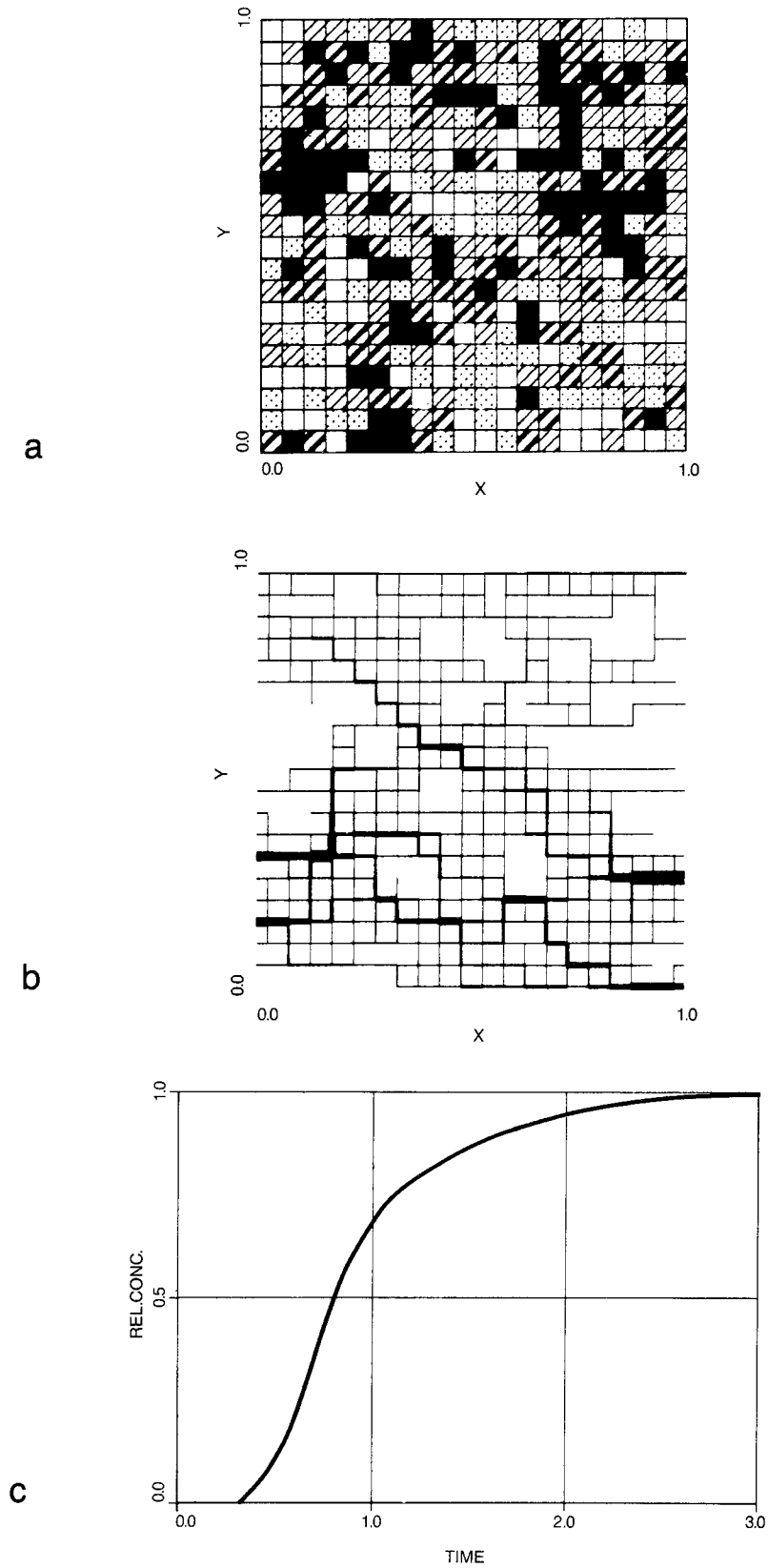

Figure 16-3.

- a) Computer simulation of a rock fracture. The black nodes represent the smallest apertures and the white nodes the greatest apertures.
- b) Calculated flow pattern in the simulated fracture.
- c) Calculated breakthrough curve for a non-sorbing tracer injected in the calculated flow.

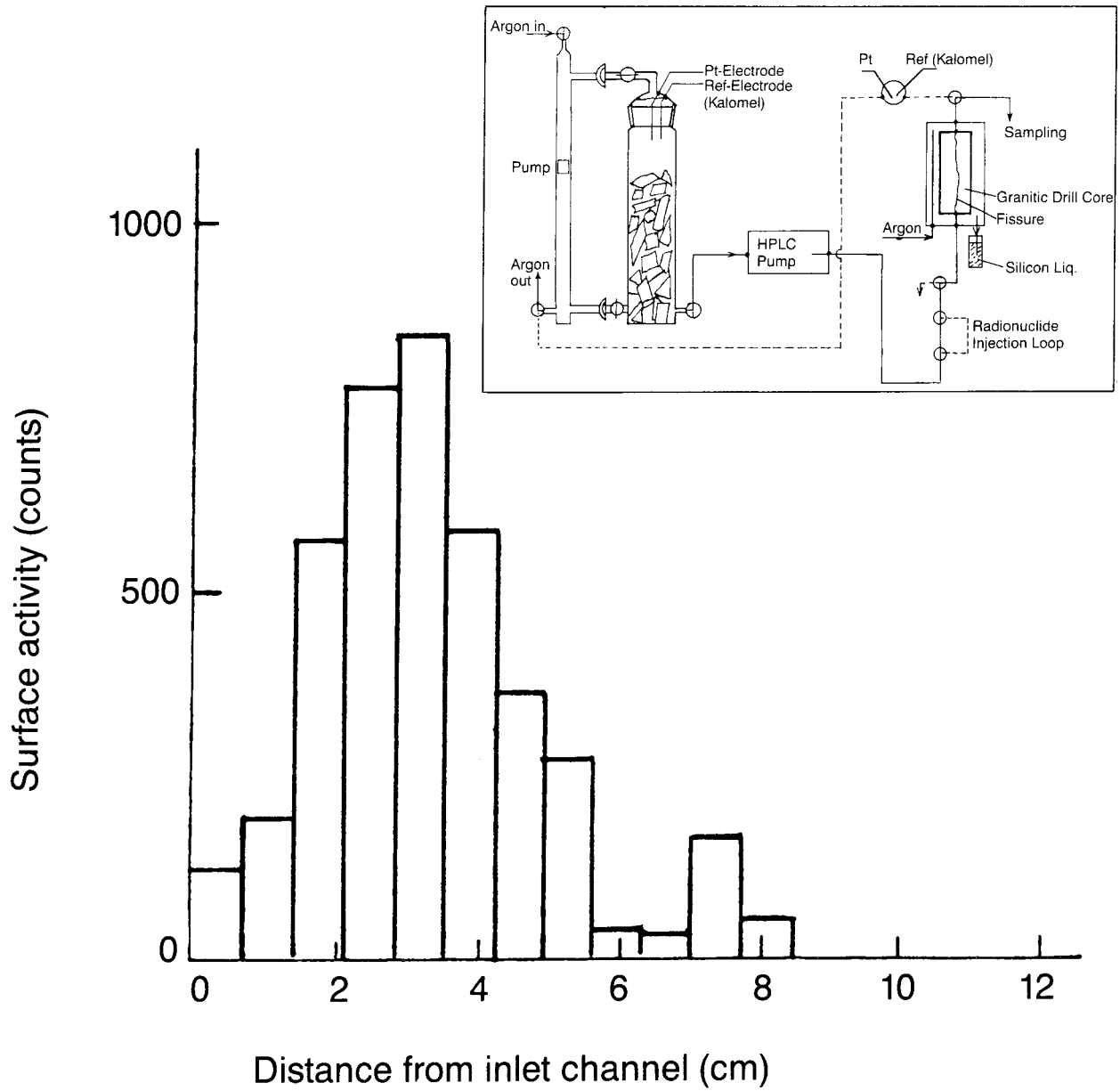

Figure 16-4. Measured activity on the fracture surface after injection of ^{99m}Tc in an overcored fracture from granitic rock (Stripa). The fracture have been opened and analyzed after use in a flow through experiment in an equipment for migration studies in a simulated reducing environment.

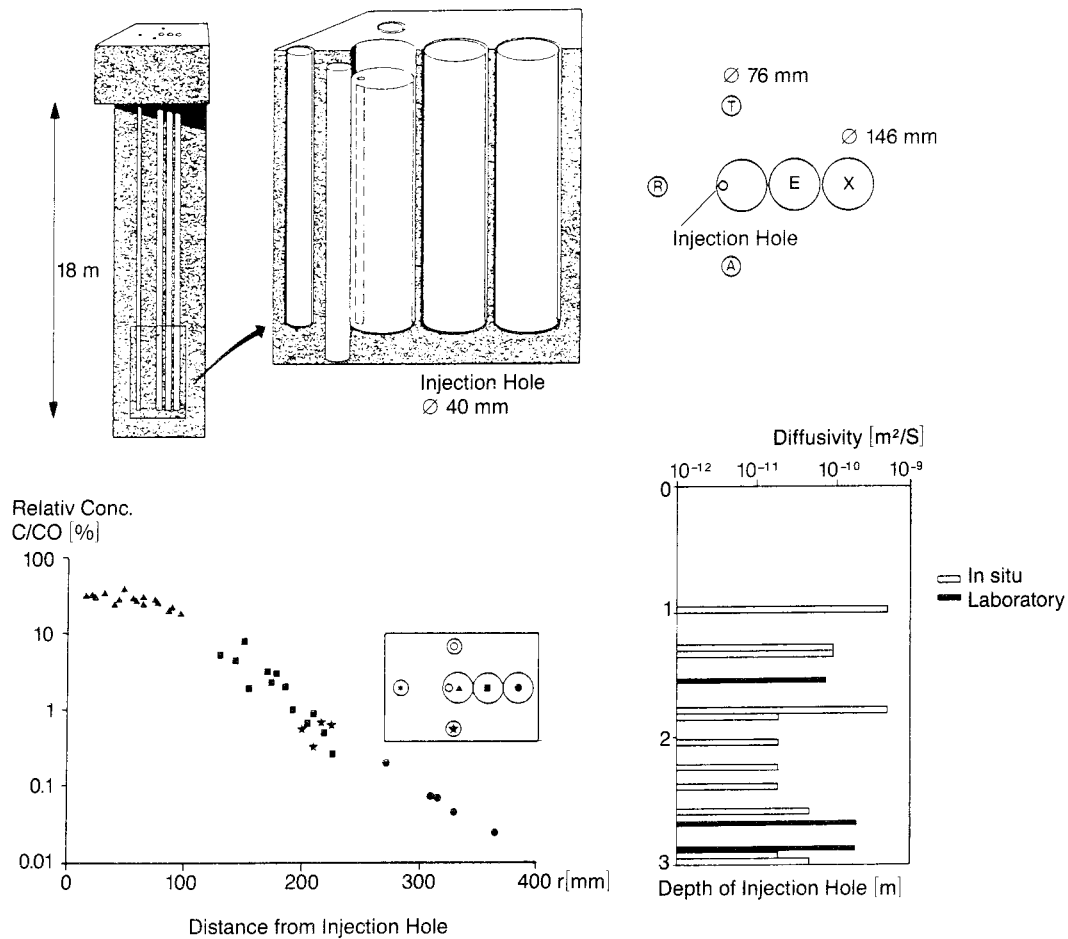

Figure 16-5. In-situ measurements of the diffusive properties of undisturbed granitic rock. Non-sorbing tracers have been injected over 3.5 years in the 3 m long, 40 mm diameter injection hole. The injection hole have been overcored for sampling and samples have also been taken from additional core-drilled holes. Laboratory measurements of rock diffusivities have been made for comparison.

17 SAFETY ASSESSMENT

17.1 GENERAL

The safety assessment activities within SKB have been related to four main areas.

- An evaluation of the feasibility, safety and development potential of the WP-Cave repository concept in comparison with the reference concept KBS-3.
- A cooperative scenario identification exercise together with SKI and NEA.
- A study of carbon-14 in the reactor system and the repository environment.
- Further development of the PROPER code package.

These areas will be discussed below.

The flow model for coupled groundwater and heat flow calculations, GWHRT version 1.0, is now documented /17-1/, and implemented and tested on the SUN computer of SKB. Another computer model for geohydrology modelling, the NAMMU package, has been purchased from Harwell Laboratory.

Within the international INTRAVAL project attempts are made to validate geosphere transport models. Two SKB groups have participated with predictive modelling for the radially converging tracer experiment in Finnsjön.

A planning for the next major Safety Assessment Report on the final disposal of the spent nuclear fuel has started. It is called SKB 91 and is planned to be published at the end of 1991. The main objectives for SKB 91 is to provide an opportunity to integrate the present knowledge on final disposal, to evaluate the role of the geologic barrier and to provide a less conservative evaluation than the KBS-3 as a reference for future variation studies.

17.2 WP-CAVE EVALUATION

SKB is required to perform the research needed to evaluate various disposal methods and to select a site and repository system for the final storage of spent nuclear fuel in Sweden. An effective approach requires a successive focusing of the R&D efforts. Thus an effort must be made to evaluate the performance of feasible alternative repository concepts, to compare them and to assign priorities to them.

For this purpose a special group, SFG (the integrated performance group), was formed within SKB in 1987. During 1988 SFG has evaluated the WP-Cave concept in comparison with the reference concept KBS-3. The evaluation consisted of a comparison of

- technical feasibility with regard to present technology,
- cost effectiveness,
- radiological safety and potential for development and
- uncertainties and confidence.

In principle the comparison highlighted the differences between a concentrated disposal option in a small highly engineered rock volume and a distributed disposal option adapted to local bedrock characteristics (cf Chapter 10). The main parts of the job was finished in December, 1988.

The comparison between the WP-Cave and KBS-3 concept has resulted in the following conclusions:

- Both concepts are judged to be able to provide adequate safety.
- A utilization of the potential of the WP-Cave requires, however, extensive development in areas where the current state of knowledge and available data are incomplete.
- The higher temperatures in the WP-Cave lead to greater uncertainty as to longterm performance. Reducing this uncertainty would require many years of research and substantial resources.
- Both repositories, including the barriers they incorporate, could be built with a normal adaptation of available technology.
- It is not possible to say today whether it would be simpler to find suitable sites for one design or the other.
- The WP-Cave is considerably more expensive.

A future research direction based on a concentrated emplacement of spent fuel along the lines of the WP-Cave is therefore judged to entail greater uncertainty as regards the possibilities of achieving acceptable safety and to require greater resources for research and development, at the same time as the costs of building the repository would be higher.

The studies of the WP-Cave as an integral system should therefore be discontinued. The research should be focused on distributed systems with lower temperatures, in accordance with the basic KBS-3 concept.

Certain barrier designs in the WP-Cave could also be utilized in repository designs with lower temperatures, for example the reduction potential of the steel canisters and the hydraulic cage's diversion of groundwater. Studies within these areas are being conducted within SKB and should continue.

The report will be published during 1989.

17.3 SCENARIOS

In September 1988 SKB started a joint scenario analysis project together with SKI (The Swedish Nuclear Power Inspectorate). The motivation for this project is that there is a need for a common understanding on principles and procedures for scenario selection well in advance of the licensing process. The project will be reported in a final report early 1990. After this first phase scenario development, as well as consequence analysis of the derived scenarios, will be performed within each organization separately.

17.4 CARBON-14

A compilation and critical evaluation of the present data base regarding carbon-14 in the reactor environment, in the repository and in the biosphere has been made. A draft has been circulated for comments and the report will be published during 1989.

17.5 PROPER CODE PACKAGE

The PROPER code package is designed to assist the analyst in performing uncertainty and sensitivity analysis in model calculations. The PROPER Monitor is a computer program to be used by other programs: it links together a number of submodels selected from a

library at run time and carries out an analysis on the desired outputs. Postprocessing codes belonging to the system can be used to treat the results statistically or graphically.

The work on the Version 1.0 of the Monitor was completed in 1988. New submodel were also added to the existing libraries.

The new nearfield submodel computes radionuclide migration rates from the nearfield of a KBS-3 design spent fuel canister. Diffusive transport of chemical species, canister corrosion, solubility limitations under oxidizing and reducing conditions, washout of the fuel-to-clad gap inventory and chain decay are all taken into account.

The new farfield model calculates migration rates of radionuclides in the farfield given the release rates from the nearfield. Advection, dispersion and matrix diffusion/sorption are taken into account as well as chain decay.

Hydrological modeling for PROPER has also been carried out during 1988. The work continues.

The SKB is a member of the OECD/NEA Probabilistic Systems Assessments Code Users' Group (known as PSAC) and participated in the Level E code intercomparison exercise where results obtained by Monte Carlo were compared to results from another numerical method of propagating input distributions to distributions for the outputs.

18 STRIPA PROJECT

18.1 SITE CHARACTERIZATION AND VALIDATION

18.1.1 Introduction

The Site Characterization and Validation (SCV) Project focusses on the techniques and approaches used in site characterization. The central aim of the programme is to predict groundwater flow in a specific volume of rock and to compare these predictions with data from field measurements. The distribution of water flow into a drift (tunnel) will be predicted, the drift will be excavated, the inflows will be measured and compared with prediction. Above and beyond the central aim there are a number of subsidiary aims such as assessment of channelling, the small scale hydrogeological effects of drift excavation and tracer tests in the fractured rock mass.

The Site Characterization and Validation programme is based around the idea of cycles of data-gathering, prediction, and validation. Hence the programme has stages of work which can be described in these terms. In fact, the programme contains two cycles of this type where predictions are checked against observation. It is therefore divided into five stages as follows:

Stage	Title of stage	Period	Type of work	Cycle
I	Preliminary site characterization	86-88	data gathering	first
II	Preliminary prediction	87-88	prediction	
III	Detailed characterization & preliminary validation	88-89	validation/ data gathering	second
IV	Detailed predictions	89-90	prediction	
V	Detailed evaluation	90-91	validation	

The programme of work contains a number of different techniques falling within the disciplines of structural geology, geology, geophysics, chemistry hydrogeology, and modelling. These have been combined so that predictions can be made and subsequently validated. The "cycles" of the programme envisage two modelling periods in which predictions would be made. These two periods are very different. In the first (Stage II), a conceptual model is made which is essentially geometrical with preliminary values of the important properties. Modelling at this stage will make primarily

geometrical predictions. In the second (Stage IV), modelling will include the detailed properties and will include predictions of inflows to the test drift.

As can be seen Stage III fulfills two functions, that is the data gathered at this point in the programme will be compared against the preliminary predictions resulting from the Stage II work. They will also provide a basis for the detailed prediction in Stage IV. Stages I and II were completed during 1988 and Stage III is currently in progress.

18.1.2 Conceptual Model of the SCV-site

The major effort during 1988 has been the compilation and integrated interpretation of the data collected during Stage I. The resulting interpretation has been presented in a report titled "Site Characterization and Validation Stage 2 – Preliminary Predictions" which is summarized below.

The rock type at the SCV-site is granite with small lithological variations. The granite is traversed by regionally visible fracture zones with spacings around a kilometre. This compares with the 125 m sides of the volume being investigated. The mine opening affects the regional hydrogeology and the regional stress field. It intercepts regional groundwater flow paths, some of which are up to 10 km in length, and over the period of mine operations it has reversed some flow away from the nearby Lake Råsvälen.

The SCV site lies within a local groundwater flow system where the mine acts as a sink. In this system "young" low salinity groundwater flows downward towards the mine and mixes with "older" more saline water flowing upwards from depth. Near the surface, waters are almost exclusively "young", whilst at depth (i.e. > 400 m) waters are "old". The site therefore lies within a zone of mixing between about 200 and 400 m below ground. This is reflected in the hydrochemistry of the site. The SCV site also lies within a region of stress realignment with more or less unmodified regional stress in the northern half of the site and about 30° realignment in the south.

The predictions concerning water inflows will be based on a numerical model of the mine. In reality, this is a set of 4 models at increasing detail; a regional model, a sub-region model, a "mine" model, and a "site" model. The first two parts were completed during the previous phase of the Stripa Project. The large region model assumes boundary conditions such as the topography of the water table and surrounding impermeable borders. The head and flow distribution is then calculated within the modelled region. The boundary heads and flows for

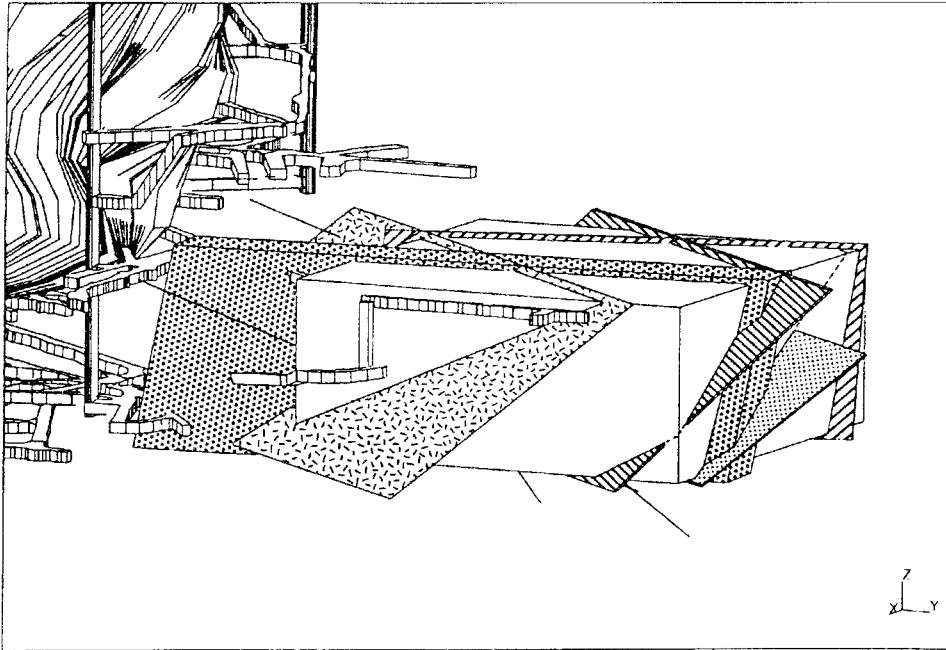

Figure 18-1. Perspective view of main features in relation to C boreholes and the access and validation drifts.

the three more detailed models are all based on the results obtained from the model “next up” in the series. All of these models are finite element equivalent porous medium models. However, at the most detailed level, the “site” model, a region will be modelled using a fracture network approach. This is the region of the proposed validation drift. At all stages in the modelling some fracture zones will be included explicitly as regions of distinctly different properties. Hence, the site needs to be characterized in terms of highly transmissive “fracture zones” and “background rock”.

The major structural features within the SCV site have been identified, within this phase of work, primarily on the basis of geophysical remote sensing (i.e. single borehole radar and crosshole radar and seismics). Major features have been selected mainly on how extensive they are as observed in tomograms. It has also been found that there is a general correlation between radar “slowness” tomograms and transmissivity. Using this geophysical information 5 “fracture zones” have been identified, named GA, GB, GC, GH, and GI. They all extend across the entire SCV site. They are basically in two groups (GA, GB, GC and GH, GI). The first group are aligned N40°E with a dip of 35° to the south. The second group are aligned approximately N10°W dipping 60°E. Both sets are in the order of 50 m apart but there are also other minor features in between. Figure 18-1 shows a perspective view from northeast of the major features within the SCV block.

Of the two groups, the second more steeply dipping set (i.e. GH and GI) are more extensive and more continuous. There are other features with a northwesterly strike but they are less extensive and have not been in-

cluded deterministically in the conceptual model. All features are irregular and appear in the tomograms as series of connected patches rather than as well-defined planar zones.

The rest of the rock has been characterized in terms of the occurrence of fractures. Their geometric properties (spacing, orientation, and trace length) have been measured both along scan lines in the drifts as well as in the core from the boreholes. Their hydraulic properties have been measured in the boreholes.

It is clear that there are several biases in the data. Firstly, there are two subhorizontal borehole orientations which do not sample the vertical direction very well. Secondly the drifts have a limited dimension which censors the data on trace lengths. However, although there are detailed systematic variations across the site there are essentially two well measured clusters (Clusters A and B) and a third poorly measured group (Cluster C, Figure 18-2). The fractures of Cluster A have a wide range of orientations with an average strike orientation of about N45W and the fractures are steeply dipping in either the northeasterly or the southwest-erly direction. The fractures in Cluster B have either easterly or westerly dips that are practically vertical with a strike of about N10 degrees. The third group, Cluster C, are subhorizontal and not very well-measured. The trace length data are strongly affected by censoring and truncation and it was only possible to make the necessary correction for Cluster C. The spacings between the clusters vary and these differences are easily seen in the different number of fractures intercepted by the bore-holes of westerly and northerly orientation.

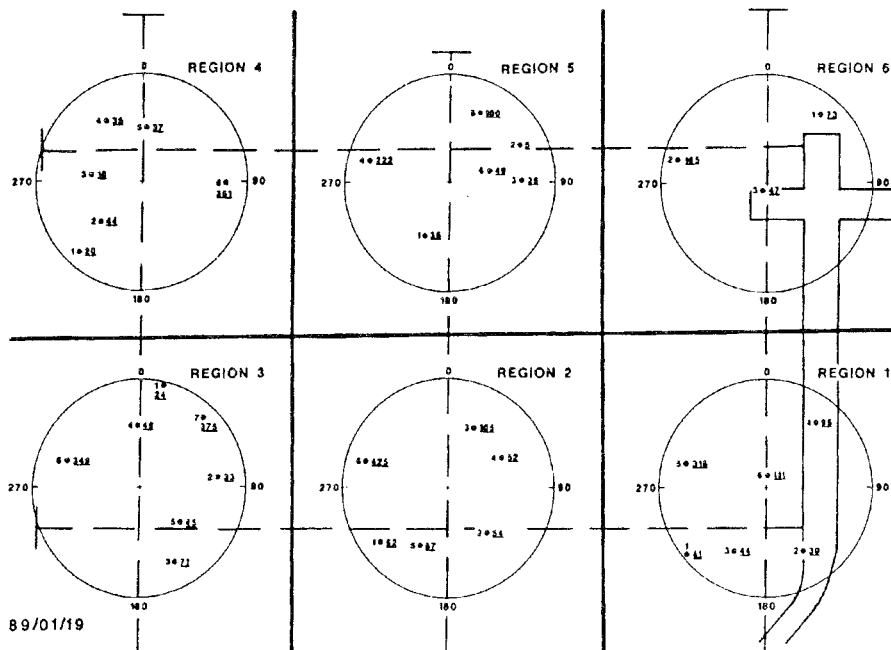
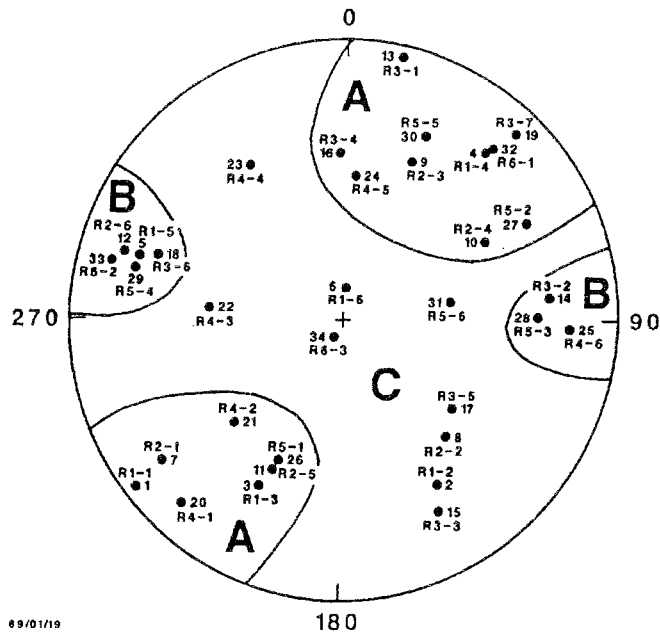

Figure 18-2. Plot of the mean pole directions for (a) all of the clusters in the SCV block and (b) the clusters in each of the sub-regions.

The hydraulics of the fractures vary depending on orientation and it seems that the mean aperture of the fractures penetrated by the W boreholes is larger than that penetrated by the N boreholes. Interpretation according to the Clusters A, B, and C is not completed.

The accurate prediction of water inflows, based on geophysical remote sensing, is dependent on the correlation between significant geophysical features and hydrogeological features. Unfortunately major geo-

physical features are defined by their extensiveness whilst hydraulic features result from single borehole tests. Single borehole hydraulic tests measure the hydraulic properties immediately surrounding the test borehole. In contrast it is known that significant extensive geophysical features are patchy. Hence it can be expected that identification of major geophysical features is a reasonable prediction of single borehole performance but a better prediction of whole drift perfor-

mance (where the effect of patchiness (or channelling) is reduced).

Examining the correlation between the identified geophysical features and single borehole hydraulic results shows some interesting features. Firstly the five major features are identified as having a thickness between 3 and 8 metres where they cross the five N and W boreholes. This accounts for 93 m of the 868 m of tested borehole. This 11 % of the boreholes contains 57 % of the total borehole transmissivity. However, the transmissivity is much more unevenly distributed with 94 % of the transmissivity measured in 32 one metre sections (i.e. 4 % of the measured length). Two of the most transmissive sections accounting for 33 % of the measured transmissivity were close to but not contained within geophysical features. If these are included within the zones to which they are adjacent then geophysical features account for 90 % of the measured transmissivity. The idea of proximity is inexact but should be justified when considering inflows to a drift.

There is at present limited evidence of crosshole responses between the boreholes of the SCV site. However, if this is combined with the head data gathered during the single borehole testing and with the long term Piezomac (head) data some factors are clear. First of all there are rapid pressure responses right across the site with speeds up to 14 metres per minute seen in one zone. Secondly there seems to be a general flow of water from the north (to the NW of the 3D Drift) towards the south and southwest. A large region of low head is found in northwest (i.e. the furthest ends of W2 and N4). The explanation for this large region of reduced heads at some distance from the mine must lie in the presence of at least one highly transmissive feature draining towards the mined cavity and probably oriented subhorizontally. This is not an orientation which is well sampled by the existing borehole layout. This also presents a prediction problem since small errors in orientation will result in large differences in intersection position.

A series of predictions are put forward in the Preliminary Prediction report. These include:

- the intersection of major features with the “C” and “D” boreholes and the access drift,
- the geological characteristics of these features where observed,
- the fracture characteristics sampled by the new boreholes and drifts,
- the hydraulic properties of the new boreholes,
- the head gradients likely to be measured in the new boreholes.

18.1.3 Current Status of Investigation Programme

The conceptual model as presented above has been the basis for locating the access drift and the C and D boreholes.

The main objective of the C-holes is to characterize a smaller volume around the validation drift in more detail. Two of the most significant zones at the SCV-site are GB and GH. These zones are likely to control the hydraulics in the central portions of the site and they have to be checked with respect to location and properties. The circular feature RQ is also an anomaly of interest and an attempt has been made to locate the boreholes so that this feature is included in the Stage III investigations. The location of the validation drift has been changed compared to original plans in order to intersect both GB and GH and to make the intersection as perpendicular as possible.

The boreholes have been located in such a way that they originate from essentially the same point (close to the beginning of W1). In this way each pair of boreholes will define a plane and tomographic surveys between the holes will be possible. The two major zones will be intersected by a large number of boreholes which will facilitate detailed crosshole hydraulic testing of the zones.

Two of the boreholes were given a steep dip in order to provide better sampling in the vertical direction compared to what has been obtained from the boreholes drilled so far.

The validation drift will intersect zones GB and GH at a relatively steep angle. The validation drift has been oriented in order to minimize the risk of it being nearly parallel to a major zone. The validation drift will be located at the 385 m level of the mine which is approximately in the middle of the investigated volume.

The D-boreholes will outline the validation drift. There will be 6 boreholes, one in the centre surrounded by five symmetrically placed boreholes. The radius of the perimeter where the boreholes will be located will be 1.2 m. The intention is that the validation drift should have a diameter of 3 m which would make it possible to contain the boreholes within the diameter of the drift.

The location of the new boreholes, access and validation drift in relation to the mine workings and the existing boreholes are shown in Figure 18-3. Figure 18-4 shows the zones with existing and new boreholes in a vertical section at the X-coordinate 440, i.e. the vertical plane of borehole W1.

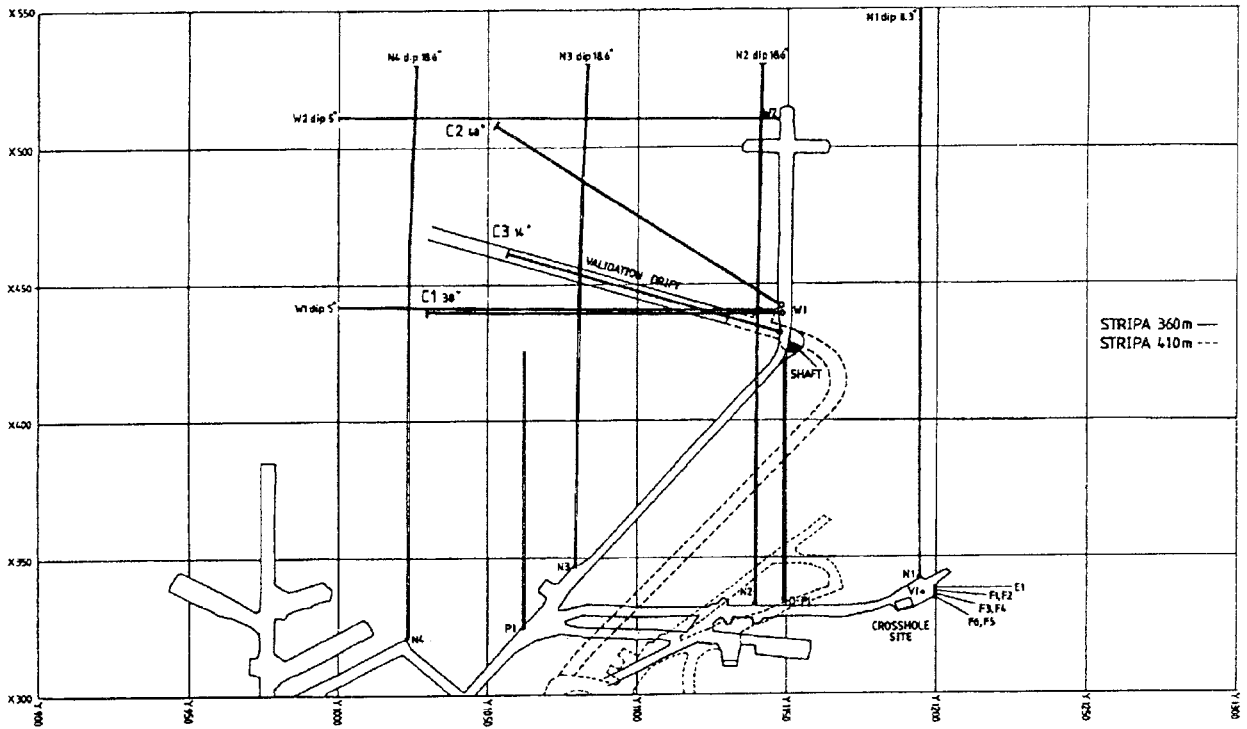

Figure 18-3. Location of C-boreholes, access drift, and validation drift. Solid; 360 m level, dashed; 410 m level.

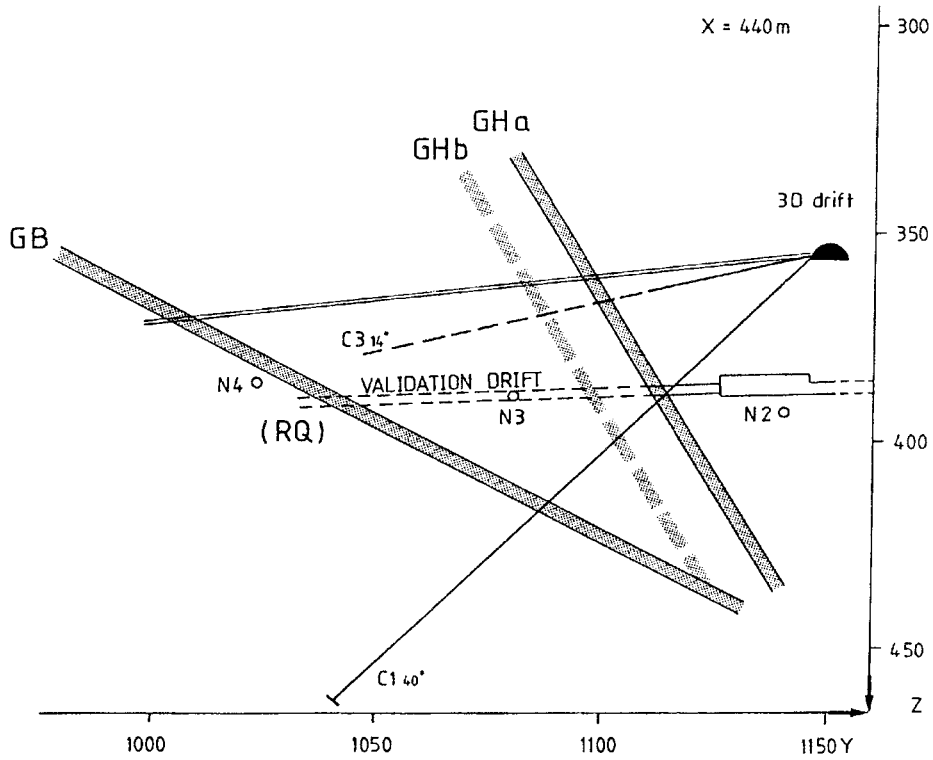

Figure 18-4. Vertical section at the coordinate $X = 440$ m in the mine system. Location of C-holes, validation and access drift are indicated in relation to the major features GB and GH.

18.2 DEVELOPMENT OF HIGH RESOLUTION AND DIRECTIONAL RADAR

The theoretical analysis has demonstrated that there are two possible concepts for a directional antenna: either a simple antenna that would be rotated mechanically in the borehole or a more complicated system, where the rotation is digitally synthesized from several measurements. The second possibility was preferred, since it will simplify measurements, although the concept contains some difficult points.

The directional antenna has been constructed as an extension of the existing radar system in order to facilitate the development and avoid extra work. The main novelties are

- 1) a direction indicator to measure the position of the antenna in the borehole;
- 2) a fourth optical fibre communicating in both directions with the direction indicator and the switches to the antennas;
- 3) a directional antenna with four antenna ports providing independent information about the incident waves.

New amplifiers and a new sampler have improved the signals, particularly at high frequencies.

18.3 IMPROVEMENT OF TECHNIQUES FOR HIGH RESOLUTION BOREHOLE SEISMICS

18.3.1 The Coherent Source

A prototype of the coherent seismic source had been constructed and tested in Stripa already during 1987. The design of this prototype was extremely simple, the main role of this unit being to verify the applicability of the concept of coherent seismic emission. The tests had proven that using high frequency coherent signals is feasible in practice and leads to the increase of resolution of the seismic measurements. This first prototype was not meant to be used for a large volume of measurements.

To cover this requirement, it was necessary during the present reporting period to put efforts into a functional and reliable design of the source itself and to construct a system of accessories which would be both safe and handy to use in a real site environment.

Figure 18-5 shows the new model of coherent source used for the tests at Stripa. The minimum borehole diameter is 56 mm. The principle of construction is presented in Figure 18-6. Two piezoelectric transducers (5) face each other along the axis of the hole. They delimitate a water filled borehole segment (6) of a



Figure 18-5. Coherent Source during Tests.

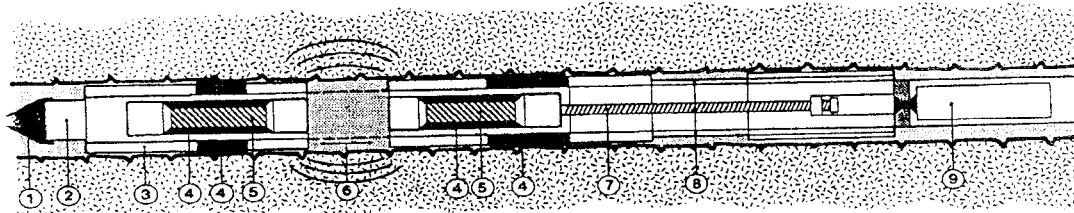

- | | | |
|--------------|-----------------------------|----------------------|
| 1. Cable | 4. Rubber | 7. Screw |
| 2. Connector | 5. Piezoelectric transducer | 8. Adjustment screws |
| 3. Sleeve | 6. Resonant cavity | 9. Electric motor |

Figure 18-6. Principle of Construction.

length adjustable by an electric motor (9) turning a screw (7) attached to one of the transducers. The frequency of the voltage which drives the transducers can be controlled from the surface. It is thus possible to achieve a resonance condition and the energy is conveyed to the rock with a high efficiency rate. If the segment of borehole in which the source is placed is not naturally water filled, one can use a packer.

A field data acquisition and processing unit had also been assembled during the previous reporting period around an industry (IBM) standard personal computer. This solution had been chosen considering the rapid development of this type of machines, the increasing number of hardware options and their wide availability.

It was thus possible during 1988 to add to the system a vector processor which increased the computational speed considerably. The increase of speed is necessary if data processing at site is to become a realistic option.

The data used previously to test and calibrate the software had mostly been borehole hammer data. The coherent source data, obtained during 1988, revealed new possibilities of using the higher frequencies and the stability of the source signal.

Figure 18-7 shows a set of seismograms recorded at Stripa by sliding the source in the borehole at a 0.5 m increment. The high frequency (6 kHz) gives a reliable travel time pick, the error being less than 0.05 % over a 200 m distance from source to receiver. This represents roughly a tenfold increase of accuracy with respect to the previously used techniques, which may lead to an important increase of resolution of velocity tomographic surveys. Figure 18-8 shows the calculated envelopes of the same signals. The energy travelling as p-wave can be accurately estimated, which opens the way towards seismic amplitude tomography.

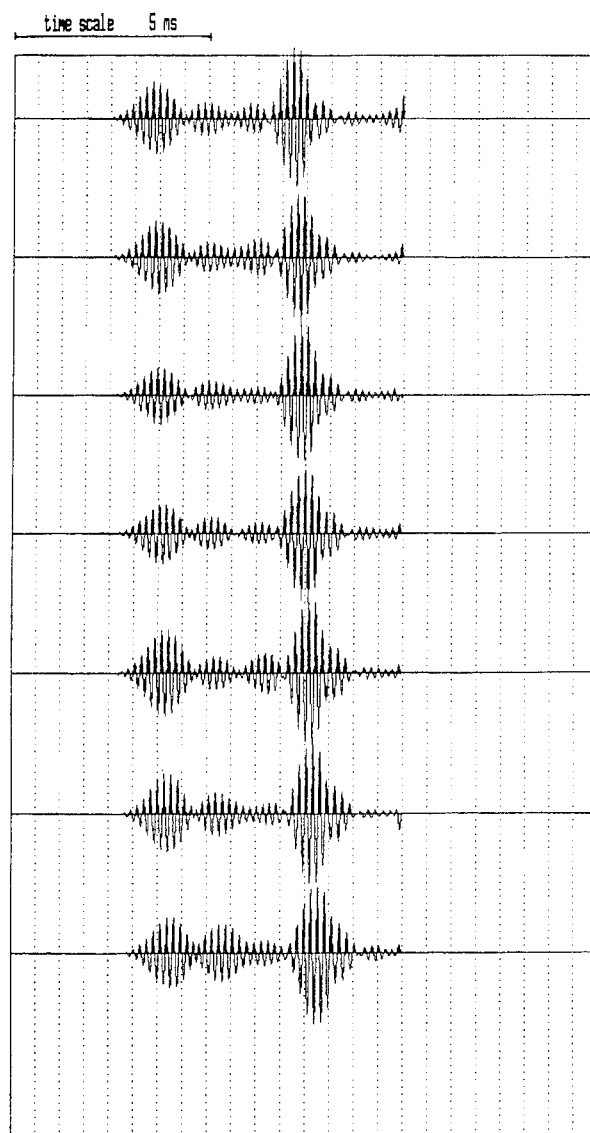

Figure 18-7. Seismogram signals.

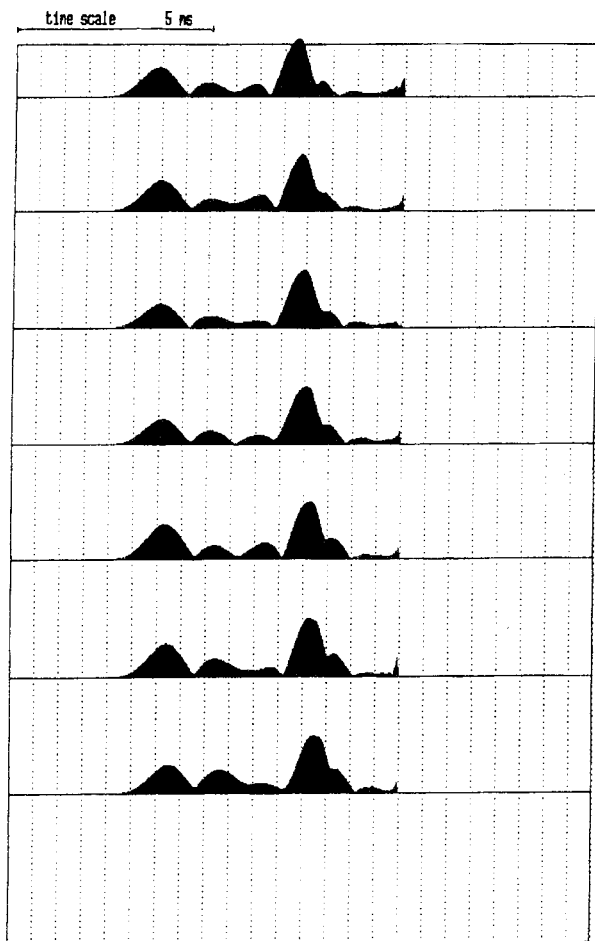

Figure 18-8. Envelopes of signals.

18.3.2 Processing and Interpretation Routines

The software developed till the beginning of the present reporting period had been centered on an inversion procedure based on the P-Tau Transform. This approach produced good results in enhancing weak reflected events from features with very diverse positions and orientations in space. This had been an important obstacle to overcome, because the seismic industry had few established procedures applicable in crystalline rockmass. The work done during 1988 was aimed at refining the algorithms and rewriting the code for use on vector processors.

18.4 FRACTURE NETWORK MODELLING

18.4.1 General

Phase 3 of the Stripa project provides an opportunity to study a previously undisturbed volume of Stripa granite in great detail. It is important to understand groundwater flow and transport through such rock, since hard,

fractured rocks provide possible locations for radioactive waste disposal sites. Field experiments involving tracer transport in fractured rocks have not been fully explained using conventional continuum approximations such as Darcy's law. In these rocks, groundwater flow and transport takes place primarily through a network of connected fractures and it is hoped that a more direct model might build understanding. One of the goals of Phase 3 of the Stripa project is to validate the fracture network approach. In this approach we calculate flow and transport through fracture networks, which are generated numerically to exhibit the same statistical properties as those measured in the rock. We must show that important properties of the flow field depend only on these statistics and are independent of details of the individual fractures which make up the network. Further, we must show that all the necessary input data for the models can be collected and that the results we calculate are accurate and in agreement with the field measurements.

The Stripa project sponsors the fracture network modelling work carried out by the Harwell Laboratory of the U.K.A.E.A; a collaborative effort is provided by the U.S. Department of Energy – at Lawrence Berkeley Laboratory and Golder Associates. At the 1988 Joint Technical Committee meeting, a Modelling Task Force was set up. This forum aims to coordinate the work of the three modelling groups, recommend criteria for the verification and validation of their numerical models, and to facilitate the wider dissemination of progress in the development of this approach amongst the countries participating in the Stripa project. The first two meetings of this group took place in California and Kyoto, and have already led to a much better understanding between the groups and a coordinated research programme. The following sections describe the progress we have made in developing our numerical models and in applying them to the Stripa site. We conclude with a description of the preliminary work that will lead to our predictions of the experimental results. This prediction will form the basis of the validation of our approach.

18.4.2 Development of Computer Codes

The Stripa project funds the development of the NAPSAC computer code at Harwell. During 1988, NAPSAC has been extended from what was primarily a research tool, into a computer code that can be used to simulate real experimental sites. This has involved a significant enhancement of the data structure of the computer code. NAPSAC can now simulate flow through quite general geometrical regions composed of a number of distorted cuboids. This particular geometry was chosen so as to facilitate the interface between regional simulations using finite-element models, and the boundaries of NAPSAC models which, because of their numerical complexity, must generally simulate relatively small regions. Within this new data structure, we have

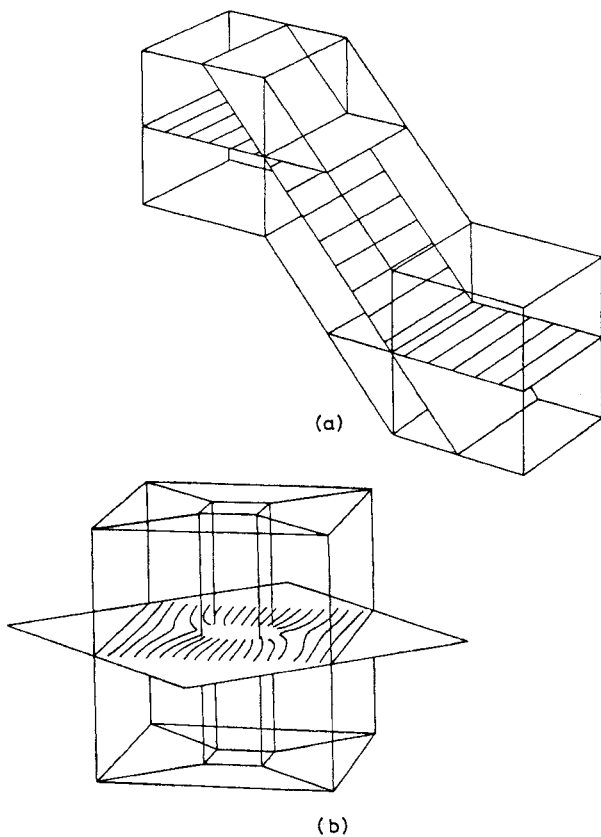

Figure 18-9. Two test cases illustrating pressure head contours on fractures within complex regions.

considerably extended the range of output options. These include options to perform trace mapping and core logging within the numerically generated networks. This will enable us to check the consistency of the fracture data interpretation techniques. We can also plot contours of the pressure head on selected planes in the network: a first step towards visualising the calculated flow fields. Two simple examples used to test the new features are shown in Figure 18-9.

We have begun the documentation of NAPSAC and have demonstrated the portability of the NAPSAC package by installing it on a Convex computer at Lawrence Berkeley Laboratories and on a Cray XMP system. These two tasks are required if we are to transfer the technology we are developing to the countries participating in the Stripa project.

Golder Associates use their PC based interactive fracture network generation code, Frac Man; and a fracture-water flow and solute transport code, MA-FIC/T. Their development work related to the Stripa project has focussed on developing more realistic fracture network generation schemes. These include schemes which model fracture termination modes, and also allow correlations in the fracture locations. This al-

lows for the stochastic generation of fracture clustering and of fracture zones.

Lawrence Berkeley Laboratory have focussed their model development on an inverse approach, as opposed to the forward modelling of the other two groups. They have developed an annealing algorithm which they have applied to their hydrological modelling codes. The scheme first generates a very general 'template' model and then automatically constrains this network using hydraulic, geophysical and geological data.

The inverse approach requires cross-hole data, spanning the modelled region. Where this is available, the algorithm developed by Lawrence Berkeley Laboratories provides a very elegant scheme for fully utilising data directly from hydraulic and geophysical experiments.

Finally, as part of our computer code development, the three groups have prepared a report defining a plan to verify their respective computer codes. The plan includes test cases to verify the accuracy of the network generation schemes and of the flow calculations, using a mixture of analytical results and cross comparison between the independent compute codes. Preliminary results, prior to the final definition of the test cases, indicate broad agreement between the programs although they have served to highlight the approximations used by the three computer codes.

18.4.3 Data Interpretation and Experimental Support

Network models have quite different data needs to more conventional models. The data to be used is mainly in the form of probability distributions of local properties of the fractures. Whilst such local properties are more amenable to measurement than bulk properties of fractured rock; the models require a great deal of data and the parameters of the probability distributions must be inferred from the measured quantities.

The hydraulic tests have been interpreted by experimental groups to give a transmissivity for each tested interval. Such intervals may contain several distinct fractures. Harwell and Lawrence Berkeley Laboratory have written a small program to calculate maximum-likelihood estimates of the parameters for the effective hydraulic transmissivity distribution. The program is based on the assumptions that the fractures intersecting a given measurement interval are independent and that all fracture transmissivities belong to a single gamma or log-normal distribution. Neither of these assumptions are strictly true; however, of more concern is the assumption of two-dimensional plate flow. If we use such a model, then we require an effective 'cross fracture' transmissivity. Golder Associates have performed numerical experiments, analogous to those performed in the mine, with different forms of aperture variation over the fracture plane. The results suggest that what has been measured is the transmissivity of the part of the fracture plane adjacent to the

borehole. This may be quite different to the effective transmissivity of the plane as a whole. Their results emphasize the importance of having a conceptual model for the fracture which accounts for transmissivity variation or channelling. Lawrence Berkeley Laboratory, too, have been investigating the interpretation of transient well tests, proposing a fractal model. The modelling teams are actively involved in supporting the design and interpretation of the channelling experiments performed by Professor Neretnieks.

Example results, calculated by Golder Associates for two alternative conceptual models of the channelling experiment, are compared to preliminary experimental results in Figure 18-10.

As well as hydraulic tests in the averagely fractured rock, there are a number of cross-hole tests proposed to study flow in the fracture zones identified by geophysics experiments. Lawrence Berkeley in particular are developing models of these zones based on geophysical and geomechanical evidence. Their inverse approach will be particularly useful when interpreting the hydraulic results, and they are supporting the experimental design.

Lawrence Berkeley Laboratory have also been considering the difficulties of deriving fracture length data from distributions of fracture trace lengths observed on tunnel walls. As they show in Figure 18-11, very different length scale distributions may produce indistinguishable trace length distributions. To obtain the fracture length distribution from fracture trace maps, we will have to make a number of assumptions about the form of distribution.

A final area of concern which we have studied is the possibility of measuring correlations between the fracture data distributions. Auto correlations of orientation and of location are observed. A correlation between fracture aperture and length might significantly affect the predicted flows. One experiment where we hoped to measure this involved measuring fluxes into intervals along the D-holes and subsequently identifying the traces of flow-conducting fractures on the validation drift walls. Numerical simulation of this experiment by a Harwell and Lawrence Berkeley Laboratory team, and also by Golder Associates, indicated that the results for this experiment may be inconclusive. To get even a qualitative result would require a reduction in the interval size of the flow tests. Such a reduction is included in the latest plans and the data will, in any case, be collected, but our expectations for evaluating correlations are low.

18.4.4 Predictive Modelling

The data required for our network models of the SCV-site was not yet available at the end of 1988 and so models were being constructed with preliminary datasets. It became clear that major revisions would be required to these datasets and so, for economic reasons, work with preliminary datasets was restricted.

Harwell's work on the preliminary dataset was restricted to considering representative volumes of rock containing networks realising the observed fracture property distributions. Not all fractures could be accommodated within our network models, and indeed it is inefficient to model the many fractures that play an insignificant role in the groundwater flow system. We therefore aimed to assess the effect of truncating the observed transmissivity or length scale distributions, so as to include only the most transmissive or the longest fractures in our models. This approach depends upon sensitivity studies demonstrating that we are including sufficiently many fractures to account for the bulk permeability of the rock. Sensitivity studies were carried out which indicated that choosing the longest, and so most highly connected, fractures led to an excessively complicated numerical problem. NAPSAC could only include some 3000 fractures: far too few. When considering the most conductive fractures, results were more promising. With some 10,000 fractures in the model we could accommodate nearly 2% of the fractures in a 50 m cube of rock based upon the preliminary dataset. This was still too few. However, in the latest dataset there is a lower fracture density, and we are optimistic that we can accommodate more than 5% of the fractures. Harwell estimates that this proportion of the fractures will carry the bulk of the flowing groundwater. A further outcome of this study was that an unphysically large permeability was predicted when fracture aperture was correlated with fracture length-scale. This does not entirely rule out such a correlation since the assumption of parallel-plate flow most likely implies an unphysically high connectivity in the network. However, this interpretation of transmissivity is consistent with the parallel-plate flow assumption and for the present we shall continue with this approach, and also assume that apertures and lengths are uncorrelated.

The boundary conditions for our network models will need to be specified around the edges of the SCV-site. There are no 'natural' boundary conditions here and so they will be provided by a continuum, porous medium, 'mine' model which extends to include the mine workings which are at fixed atmospheric pressure. This model, in turn, takes some of its boundary conditions from a more regional model which extends out to natural flow boundaries. The mine model has been constructed by Professor Gale, and, since it contains a number of elements around the validation drift, can be used as a predictive tool itself. The geophysically identified fracture zones are presently being properly incorporated in the model. Flux predictions and boundary conditions for network modelling will shortly be available.

The other two groups have also been awaiting data for their models, and in the meantime have been considering alternative approaches. Golder Associates have developed a stochastic continuum model of the region surrounding the drift, accounting for heterogeneity of the medium by a stochastic variation of finite-element

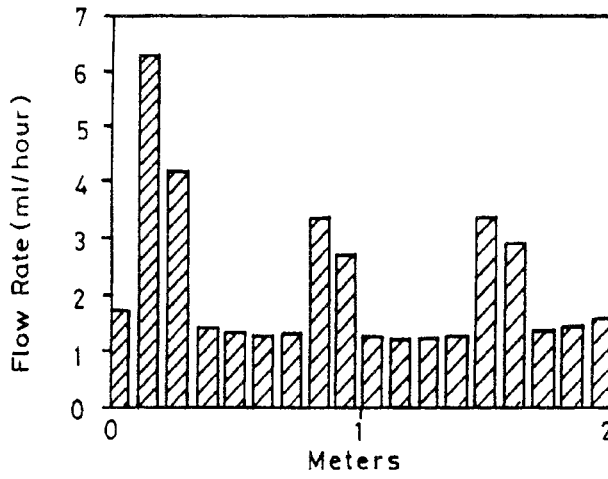

(a) Simulated Flow Distribution, Strong Linear Channels

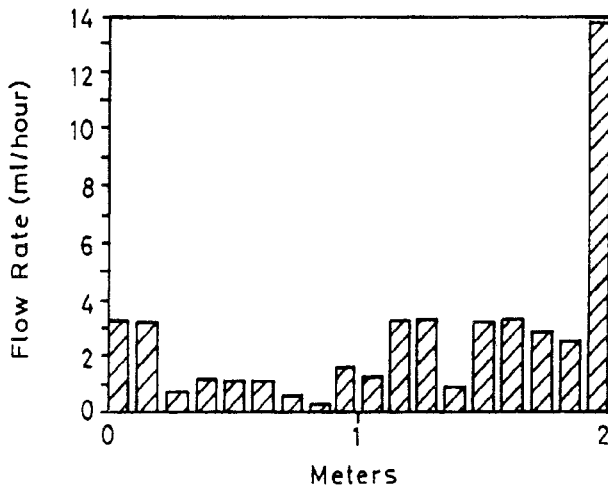

(b) Simulated Flow Distribution, Random Transmissivity Distribution

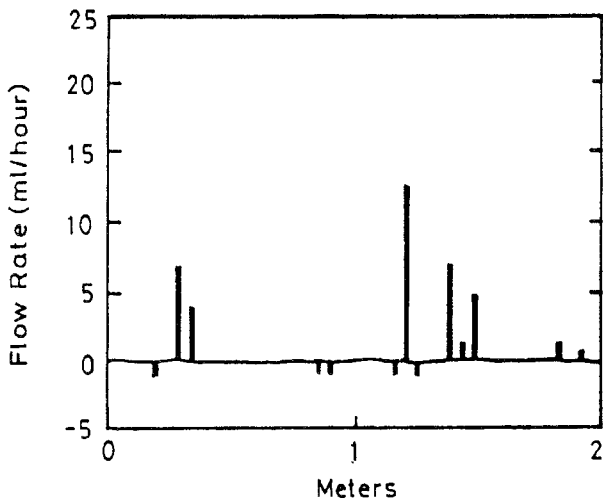

(c) Example Experimental Flow Distribution

Figure 18-10. Comparison of numerical simulation and experimental results for the channelling experiments.

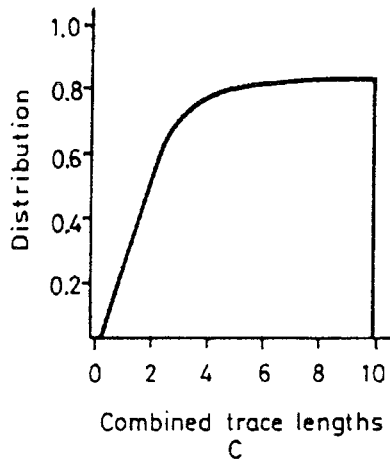
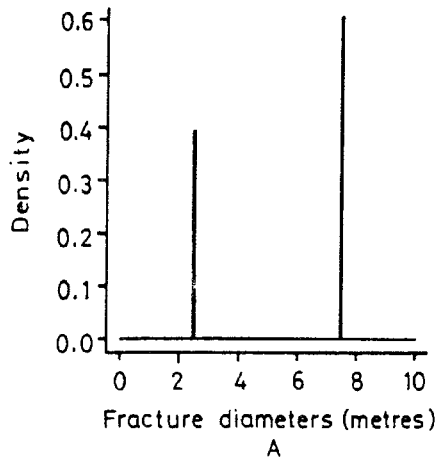

a) Trace Length Distribution, from a Fracture Set With 40% of the Diameters Equal to 2.5 Meters, and 60% of the Diameters Equal to 7.5 Meters.

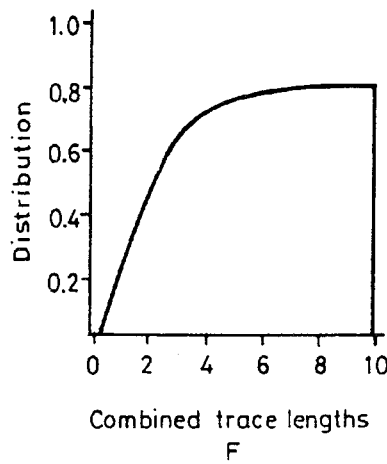
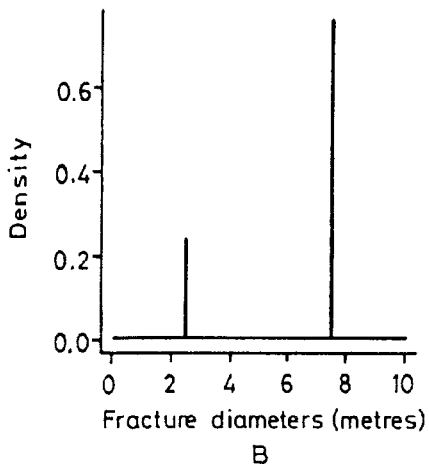

b) Trace Length Distribution, from a Fracture Set With 24% of the Diameters Equal to 2.5 Meters, and 76% of the Diameters Equal to 7.5 Meters.

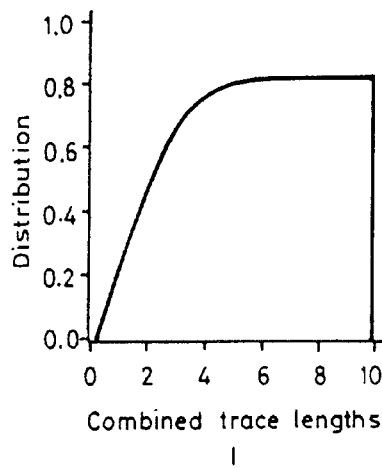
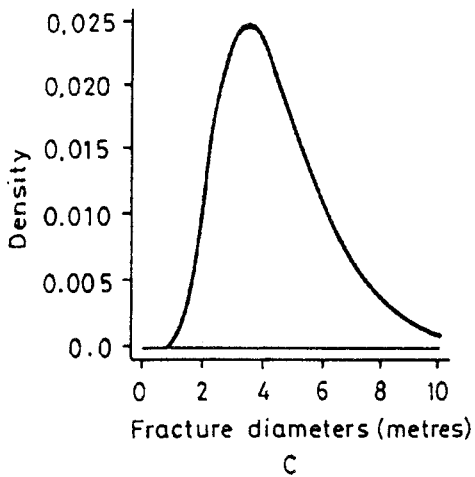

c) Trace Length Distribution, from a Lognormal Fracture Set With a Mean Diameter of 4.5 meters.

Figure 18-11. Three very different fracture length distributions and the corresponding trace length distribution.

block permeability. The stochastic properties of these blocks can be derived from smaller scale discrete fracture simulation or from conventional hydrologic approaches. This model can make predictions of flow distributions in the same way as a network model. Finally, Lawrence Berkeley Laboratory have started to develop a hydrologic model of the SCV-site, in which 80% of flow is modelled by only 7 heterogeneous, planar features representing major fracture zones. These major features are based upon, but not identical to, zones defined by current geophysical interpretations. As a result, Lawrence Berkeley Laboratory have reinterpreted the geophysical and hydraulic data to better account for hydraulic features encountered in boreholes. Well tests in these zones will be interpreted using their inverse techniques and a fractal template for transmissivity variation in the zones. This will complement their idealised fracture-network template model.

18.5 CHANNELLING EXPERIMENT

18.5.1 General

Model calculations show that channelling may have a strong detrimental effect on radionuclide transport because fast channels may carry some of the mass of the nuclides considerably faster than the average flow would and may give this portion less time to decay. Channelling further aggravates the retardation of sorbing nuclides because less surface area for sorption is available in a channel within a fracture than if the whole fracture surface area is exposed to the flowing water.

The objectives of the experiment are:

- o To study channelling Properties within single fractures (single hole experiments).
- o To study interconnection and mixing between channels within a single fracture (double hole experiment).

Frequency of and distance between channels will be studied in the single hole experiments, where up to 10 holes in several fractures will be investigated. These experiments will give information along two lines in the fracture plane.

The interconnection and mixing between channels, fracture aperture and dispersion will be studied in one selected fracture, which previously has been investigated with a single hole test. A second measuring hole will be drilled at a 1 to 2 m distance. Pressure pulse tests as well as tracer injections will be utilized in the double hole experiment.

18.5.2 Activities during 1988

Five large diameter holes (\varnothing 200 mm) have been drilled during 1988 for single hole experiments. The first hole

was used for testing equipment and injection methods. Based on these results the equipment has been modified as mentioned above. Four of the five holes have been measured with the coarse injection packer system. Two have been tested with the multi injection system.

All five holes have been photographed with the borehole camera.

The major efforts during this year have been modifications of equipment, transferring and refinements of computer codes.

18.5.3 Results and Discussion

The first fracture was tested with the multi injection system and it was not possible, with moderate injection pressures, to obtain flow rates higher than a few tenths of a milliliter per hour. This fracture can be considered as sealed and of no interest regarding water flow, however, channelling effects could be noticed.

The second hole was drilled in another fracture at the same site (single fracture migration site). This fracture showed pronounced channelling and had individual flowrates up to 15 milliliters per hour, see Figure 18-12.

These two fractures, looking similar from the drift, showed different flow behavior. This has implications on future measurements as one has to make certain that the movement of the multi injection monitoring system is worth the effort. To be able to select/reject future holes for multi injection measurements, an easily movable fast scanning device has been constructed. As soon as the hole has been drilled and photographed it will be scanned by monitoring flow rates in 20 cm intervals. These results will show if the hole has flowrates of interest.

The location of channels obtained with the scanning packer compare well with those obtained with the multi injection system.

All holes except the first one, being tight, has been tested with the scanning packer. The same effects as found in the first two holes monitored by the multi injection system have also been found in those holes only monitored by the scanning packer, i.e. one was tight and the flow in the two other holes was only in a few sections within the holes.

Out of 5 tested prominent fractures, two were so tight that no or little water can be injected and the rest showed flow over minor parts along the fracture intersection.

18.6 ROCK SEALING TEST

18.6.1 General

The general objective of the Rock Sealing Test is to identify suitable grouts and grouting techniques for sealing fine rock fractures in repositories. The grouts have to be sufficiently erosion-resistant and chemically stable to make them serve for long periods of time and

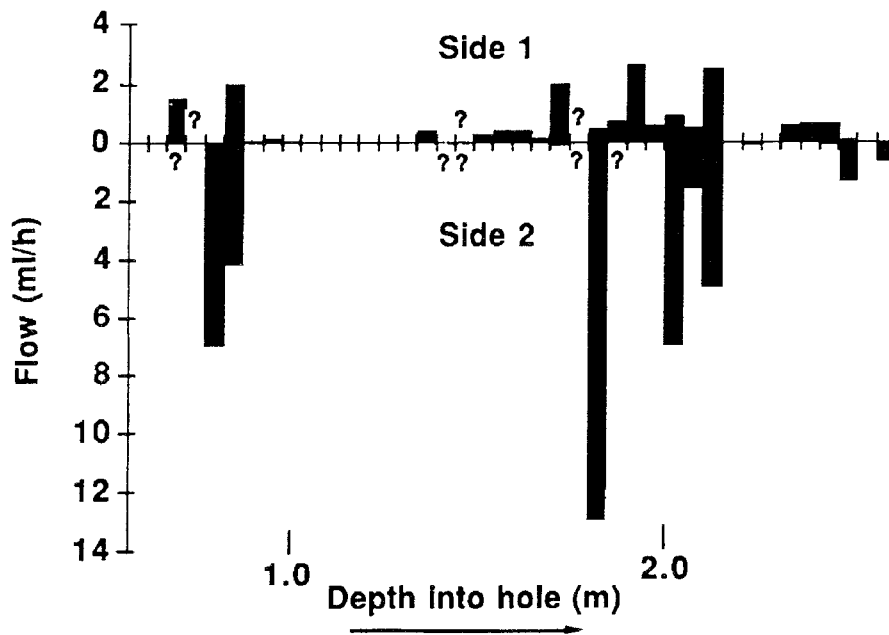

Figure 18-12. Injection flow rates in fracture 2 vs. depth.

part of the project is therefore focussed on the testing of candidate materials not only with respect to their initial sealing ability but also to their potential to survive in repository environment.

The requirement to seal fine fractures is met by use of “dynamic” injection technique, i.e. by applying vibrations of suitable amplitude and frequency to the grout in addition to the conventional static injection pressure. The project comprises development of a suitable field-adapted equipment for such grouting, and application of the technique in the mine for determination of the sealing effect and for evaluation of the validity of a grout flow theory.

18.6.2 Major Activities in 1988

The work in 1988 consisted of three major parts: 1) A large-scale pilot field test, 2) Preliminary conclusions from ongoing laboratory experiments concerning the longevity of primary candidate grouts, 3) Formulation of detailed field and lab test programs and initiation of these tests.

18.6.3 Pilot Field Test

A pilot field test was conducted in the Time Scale drift in January. Na bentonite clay gels and cement slurry were used for the grouting of four 1.5 m long and two 7 m long, as well as two 35 m long, core-drilled boreholes with 78 mm diameter. The fracture geometry and Lugeon testing gave a good hydraulic characterization of the rock and the theoretical grout flow model that had been worked out by Lennart Börgesson prior to the

experiments could therefore be used for prediction of the inflow of the grouts into the identified fractures. The agreement between theory and practice was good (cf. Table 18-1), considering the approximations that were made in the development of the flow model and the generalizations that were required in the characterization of the fracture geometry (channel configuration).

A remarkable fact is that the recorded grout penetration took place in fractures which were as narrow as a few tens of microns and that the water content of the grouts could be kept low. Thus, the cement grout, for instance, had a w/c ratio of only about 0.4, while ordinary cement grouting is successful only when the fracture aperture exceeds 300 microns and the w/c ratio exceeds unity.

After the grouting, the holes were reopened by drilling and Lugeon-tested and the evaluated hydraulic conductivity was concluded to be less than 10^{-10} m/s regardless of the original value. The last operation was to excavate the grouted tunnel floor in order to identify the flow paths of the tracer-doped grouts. About 3 m³ of rock were removed and it was found that the grout had followed channel-shaped passages in the groutable fractures to a distance of a few decimeters in the most narrow fractures to about 2 meters in the widest passages, which were formed by intersecting long-extending fractures (Figure 18-13).

18.6.4 Main Field Tests

A program for carrying out four large-scale field tests has been worked out. They will give information of how effectively rock sealing can be made in order to virtual-

Table 18-1. Comparison between predicted and measured grout penetration.

Borehole Code	Length, m	Grout	Predicted inflow cm ³	Measured inflow cm ³
i1	1.5	Bentonite	0	5 - 25
i2	1.5	Bentonite/quartz	5 - 12	5 - 25
i3	1.5	Cement	13 - 54	40 - 70
i4	1.5	Cement	42 - 62 dm ³	> 5 dm ³
i5	7.0	Cement	28 - 65 dm ³	> 7 dm ³
i6	7.0	Bentonite/quartz	141 - 254	70 - 100
S1	35	Cement	100 - 540	50 - 200
S2	35	Bentonite/quartz	10 - 54	0

ly stop water flow in the vicinity of canister deposition holes, and to shunt off water flow in major flow paths in the rock mass from deposition tunnels. The general philosophy is to develop practical tools for retarding water flow within as well as to and from a repository.

In principle, the tests can be described as follows:

1. Sealing of discrete natural fractures intersecting deposition holes. A technique for grouting large diameter holes from the inside will be tested (Figure 18-14). After grouting, the sealing power will be checked by Lugeon testing, which will be repeated after an about 8 months long heating period which brings the temperature up to around 90°C. Finally, the tunnel floor will be excavated for identification of the grout flow paths in order to validate the grout

flow theory. The design and construction of the large-sized injector and packers were made in 1988.

2. Quantification of the increase in hydraulic conductivity along blasted tunnels and shafts, and reduction of it by use of "hedgehog" and "screen" grouting. It is generally believed that blasting creates a narrow zone of fractured rock with isotropically increased hydraulic conductivity, while stress release causes anisotropic changes in conductivity. In the axial direction these effects combine to yield a high-conductivity zone close to the opening and an outer permeable zone extending a few meters outside the inner one.

The relative importance of the zones, which together are thought to cause a "superconductor" of

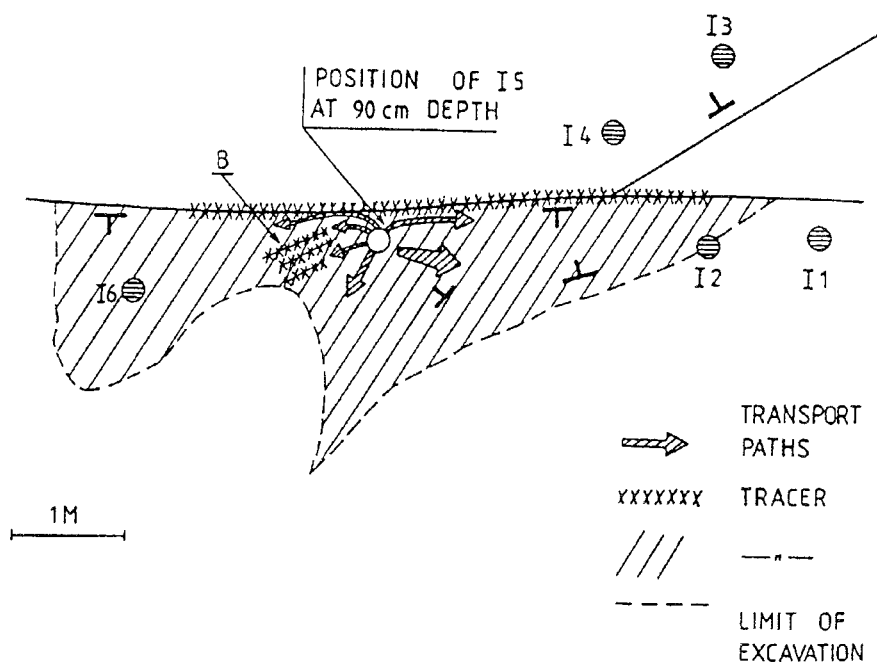

Figure 18-13. Grout migration paths at the injection of Hole I5.

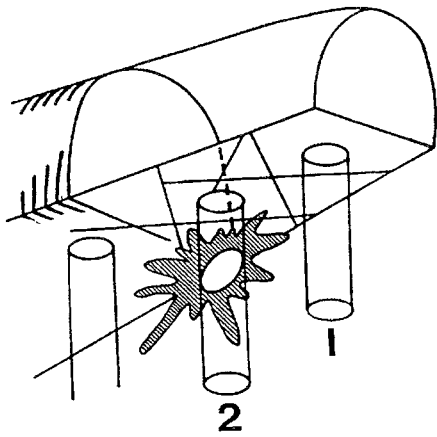

Figure 18-14. Schematic view of "in-hole" grouting of heater hole in the BMT area.

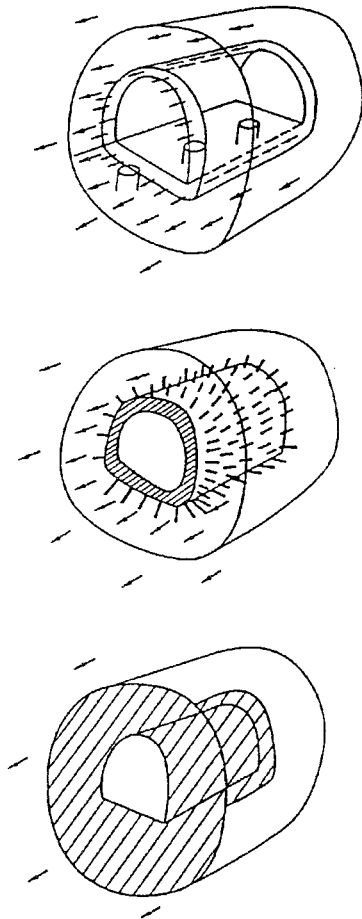

Figure 18-15. The three stages for determining the relative importance of rock disturbance. Upper: Flow is produced through the inner, blasting-affected zone and the outer zone influenced by stress release. Center: After "hedgehog"-grouting of the inner zone, water is expected to flow through the outer zone. Lower: After screen-grouting at the outer end of the drift water will flow only through the surrounding virgin rock.

vital importance for the transport of corrodants and radionuclides, will be determined by forcing water to flow along a sealed drift (BMT) before and after grouting the rock close to the drift, and, in a second stage of the test, before and after grouting the rock to a larger distance. The different stages are schematically illustrated in Figure 18-15. The study includes extensive characterization of the rock with respect to fracture distribution and conductivity, and computation of stress-related changes in water flow by applying advanced codes. The field work was initiated in late 1988.

3. Sealing of a natural, narrow fracture zone that intersects a drift (3D area). The general purpose is to find out how effectively a moderately water-bearing fracture zone of rather complex nature can be sealed, and to record how water will be redirected in the rock and how the piezometric conditions are altered around the drift as a consequence of the sealing.

The sealing effect will be determined by a low-temperature "ventilation drift" experiment combined with detailed measurement of the water given off from the sealed fractured by moisture sensor technique.

This field test, which is schematically shown in Figure 18-16, was initiated in late 1988.

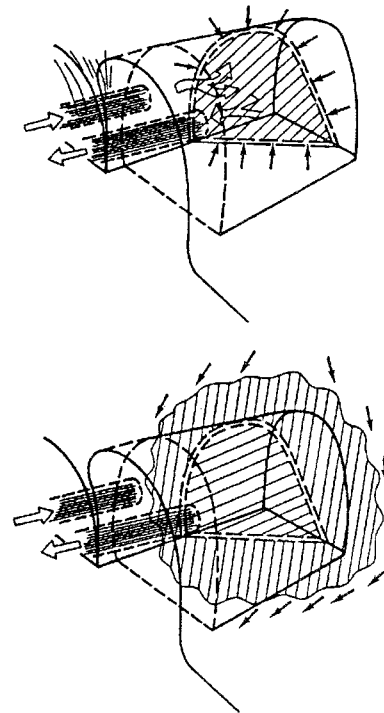

Figure 18-16. The two stages in the experiment with sealing of a natural fracture zone. Upper: Water flows into the drift from the fracture zone, the flux being determined by a "ventilation test". Lower: After sealing, water is redirected with an associated raise in pressure.

19 NATURAL ANALOGUE STUDIES

19.1 THE POÇOS DE CALDAS PROJECT

The project is studying natural analogues to the release and dispersal of radionuclides from a final repository. The investigations are performed at two sites in the Poços de Caldas region in Minas Gerais, Brazil. These two sites are the thorium and rare earth mineralization in Morro do Ferro, see Figure 19-1, and the uranium mine Osamu Utsumi, see Figure 19-2.

Participants in the project are Sweden (SKB), Great Britain (UK DoE), Switzerland (NAGRA), USA (US DOE) and Brazil (University of Rio de Janeiro, CNEN and NUCLEBRAS). The project is managed by SKB.

The introductory phase started in May 1986 and was finished and reported in 1987 /19-1/. Based on the results obtained from the feasibility study the main phase has started in June 1987 with the second project year which was reported in 1988 /19-2/. The third project year began in June 1988.

The field work comprises four core drilled holes in the uranium mine, the deepest down to about 300 m, and for core drilled holes in Morro do Ferro, the deepest down to about 80 m. Microbial sampling and geological logging of the drillcores are done in parallel with the drilling, with subsequent sampling of the cores for investigations of geochemical mineralogy. Geophysical logging and hydraulic testing have been carried out.

A comprehensive groundwater sampling program is being performed in the boreholes including monitoring of eventual changes during a year, see Figure 19-3. Sensitive parameters like e.g. pH and Eh have been measured in the field, see Table 19-1. Some analyses and sample preparations are done in a special laboratory, installed in the nearby town Poços de Caldas, see Figure 19-4.

In order to highlight the second project year and to focus the continued investigations a workshop was held in Poços de Caldas from the 22nd to 26th February 1988,



Figure 19-1. Morro do Ferro.

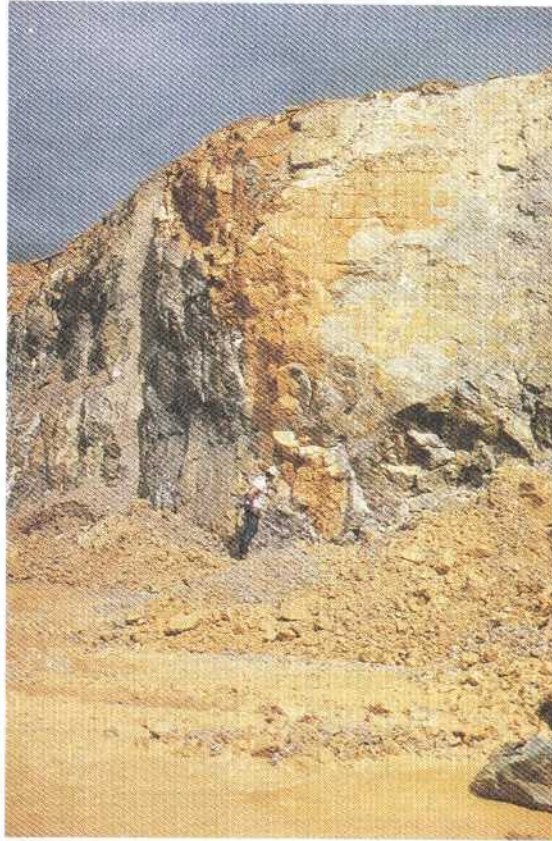

Figure 19-2. Exposed redox transition in the uranium mine Osamu Utsumi.

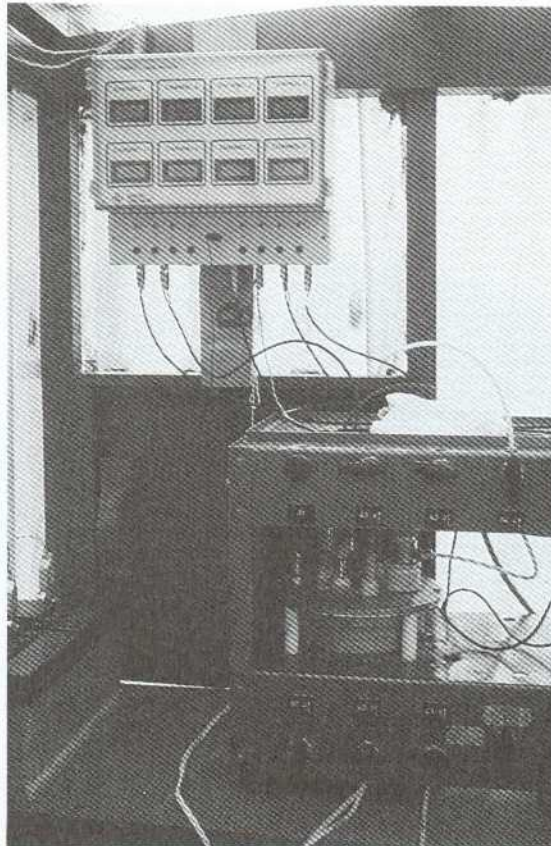

Figure 19-3. Field unit at Morro do Ferro for monitoring of groundwater pH and Eh. The groundwater is abstracted from a packed off section in the borehole.

Table 19-1. Average compositions for systematically monitored groundwaters collected from the Osamu Utsumi mine.

Sampled location	Depth range (m)	Fe (tot) (mg/l)	Fe (II) (mg/l)	U (μ g/l)	F ⁻ (mg/l)	HCO ₃ ⁻ (mg/l)	SO ₄ ²⁻ (mg/l)	pH
Auxiliary borehole 1	0-10	43-1505	7-1275	4-14400	17-168	–	560-6600	2.7
Auxiliary borehole 2	0-10	10-175	0.5-17	0.9-2.8	2-7	–	250-1010	2.6
Shaft	0-40	46	45	14-122	19	25	300	5.6
Piezometric station-22	0-(20)?	2.2	1.8	0.7	4	30	10	6.2
F2 (9-1VC24)	45-60	1.9	1.8	4	2.8	15	13	6.0
F1 (9-1WC11)	98-125	1.6	1.5	1.1	0.7	11	17	5.5

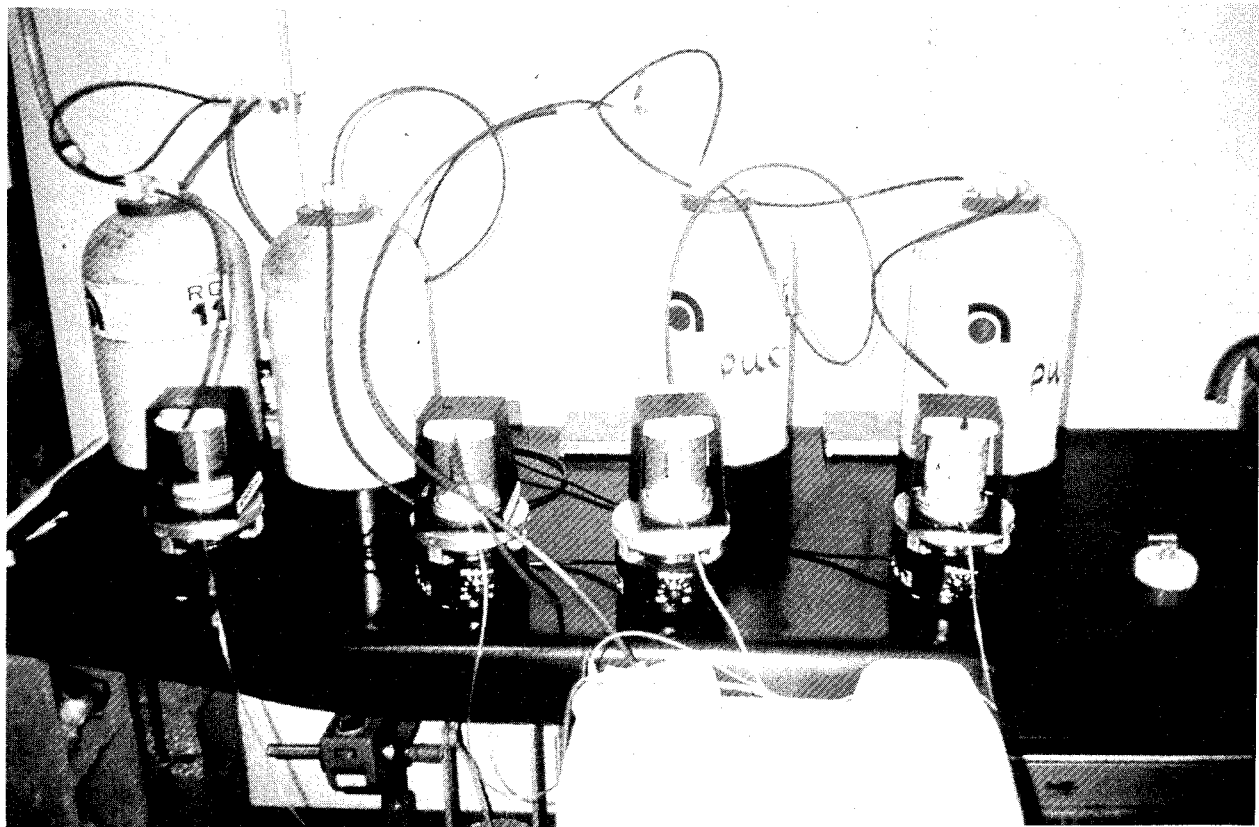

Figure 19-4. Particle filtration at the project-laboratory in Poços de Caldas.

and attended by 30 scientists from seven countries. This was an opportunity for project Principal Investigators to meet each other and the on-site personnel in Poços de Caldas, and to visit field sites and laboratory. The natural analogue objectives were defined as follows.

- 1 Assist in validation of equilibrium **thermodynamic codes and databases** used to evaluate rock/water interactions and solubility/speciation of elements.
- 2 Determine interactions of **natural groundwater colloids**, radionuclides and mineral surfaces with respect to radionuclide transport processes and colloid stability.
- 3 Produce a model of **geochemical transport across redox fronts**, aimed at understanding long-term,

large-scale movements of redox-sensitive natural series radionuclides.

- 4 **Model migration of REE/U-Th series radionuclides during hydrothermal activity** similar to that anticipated in the near field of a spent-fuel repository.

The results of the discussions on the four project objectives have been reported and used for planning purpose /19-2/.

A total of 10 quarterly reports have been issued in addition to the two annual reports. The project and isolated studies within the project have been presented at international meetings and symposia during 1988 /19-3, 4, 5, 6/.

20 DOCUMENTATION

The scientific work in the R&D programme of SKB are documented at different levels:

- in reports requested by law and submitted to the Swedish Government or its authorities such as KBS-3, R&D-programme 86 and Plan 88,
- in the series of SKB Technical Reports,
- in SKB Working Reports (Arbetsrapporter),
- in internal SKB reports,
- in contributions to scientific journals, symposia and conferences in different subject areas,
- in technical memos and notes.

Further, the bulk of basic data from geological site-characterization activities, spent fuel studies etc. are collected and stored in a data base system at SKB.

20.1 TECHNICAL REPORTS

SKB Technical Reports and many main reports, like for instance the KBS-3 report, are written in English. They are given a broad distribution to the scientific community in the nuclear waste field in order to get feedback to the program by the comments, discussions and contacts between specialists that they may give rise to. They are also used as means for the information exchange agreed upon in bilateral information exchange agreements. SKB Technical reports are filed as micro-fish at IAEA in Vienna and available through them.

20.2 CONTRIBUTIONS TO PUBLICATIONS, SEMINARS ETC

The contributions to conferences, symposia and scientific journals have been extensive during 1988, see Appendix 2.

Both SKB own staff as well as the contractors of SKB have been involved in this work.

20.3 SKB DATA BASE SYSTEM

The data from the geological site investigations are now gathered in a common database (name: GEOTAB). This database is a so called relational database, giving the investigator the possibility to freely select and retrieve complete information of high quality. The database now contains data from 40 areas with surface data plus data from about 320 boreholes in these areas. Data are structured in 6 subject areas, about 75 methods and about 300 tables. Any one of these 300 tables can be combined with any other one. Total data volume is about 400 Mbyte. New data is continuously fed into the system with a time lag since the measurement varying between one day and some weeks, depending on which quality-assurance routines that must be applied.

The programs in GEOTAB are written in C, using the database manager MIMER and is currently running heavily on a VAX-11/750 with operating system VMS. Typical response times are 10 seconds to 10 minutes for a selected retrieval from two combined tables with 10.000 records in each. It should be possible to port it to any UNIX system with minor effort.

Statistical and graphical presentation is currently provided on personal computers, to which GEOTAB offers nice file conversion capabilities.

REFERENCES PART II

CHAPTER 11

11-1 Forsyth R S, Mattsson O and Schrire D 1988

Fission product concentration profiles (Sr, Xe, Cs and Nd) at individual grain level in power-ramped LWR fuel.

SKB Technical Report 88-24

11-2 Bruno J, Casas I and Puigdoménech I 1988

The kinetics of dissolution of $UO_2(s)$ under reducing conditions. *Radiochimica Acta* 44/45 (1988) 11

11-3 Bruno J, Casas I and Puigdoménech I

The kinetics of dissolution of $UO_2(s)$ and $U_3O_7(s)$ under reducing conditions. Application of the thin-film continuous flow reactor. To be published.

11-4 Puigdoménech I, Casas I and Bruno J

The kinetics of dissolution of $UO_2(s)$ under reducing conditions: Numerical modelling. To be published

11-5 Grambow B

Spent fuel: Dissolution and oxidation. An evaluation of literature data. To be published

CHAPTER 12

12-1 Ivarsson B, Österberg J-O, Sandström R and Werme L O 1988

Creep properties of welded joints in copper canisters for nuclear waste containment. *Materials Research Society, Symposia Proceedings Vol. 127*, p. 397, Pittsburgh, PA, 1988

12-2 Ivarsson B and Österberg J-O 1988

Creep properties of welded joints in OFHC copper for nuclear waste containment.
SKB Technical Report 88-20

12-3 Marsh G P and Taylor K J 1988

The kinetics of pitting corrosion of carbon steel. Progress report to September 1988. Harwell Laboratory Report AERE-G4914

12-4 Marsh G P and Wolstenholme J 1988

Corrosion behaviour of an electron beam weld in BS 4360 carbon steel, Harwell Laboratory Report AERE-G4659

CHAPTER 13

13-1 Pusch R and Karnland O June 1988

Hydrothermal effects on montmorillonite. A preliminary study.

SKB Technical Report 88-15

13-2 Pusch R and Karnland O

Geological evidence of smectite longevity. The Sardinian and Gotland cases.

SKB Technical Report 88-26

13-3 Börgesson L, Hökmark H and Karnland O

Rheological properties of sodium Smectite Clay.

SKB Technical Report 88-30

13-4 Börgesson L

Model Shear Tests of Canister with Smectite Clay Envelopes in Deposition Holes.

SKB Technical Report 86-26

13-5 Preprints of contributions to the Workshop on Artificial Clay Barriers for High Level Radioactive Waste repositories

Lund, Sweden Oct 5-7, 1988.

Editor Roland Pusch

CHAPTER 14

14-1 SKB, 1986: Handling and final disposal of nuclear waste. Programme for research, development and other measures.

SKB, Stockholm

14-2 Gustafson G, Stanfors R and Wikberg P 1988

The Swedish Hard Rock Laboratory – First evaluation of pre-investigations 1986-1987 and target area characterization.

SKB Technical Report 88-16

14-3 Ahlbom K, Andersson P, Ekman L, Gustafsson E, Smellie J and Tullborg E-L 1986
Preliminary investigations of fracture zones in the Brändan area, Finnsjön study site.
SKB Technical Report 86-05

14-4 Larsson N Å and Markström A 1988
Groundwater numerical modelling of the Fjällveden study site – Evaluation of parameter variations. A HYDROCOIN study – Level 3, case 5A.
SKB Technical Report 88-11

14-5 Thunvik R and Braester C (1988)
GWHRT – A flow model for coupled groundwater and heat flow – version 1.0.
SKB Technical Report 88-10

14-6 Neuman S H 1988
A conceptual framework and methodology for investigating flow and transport in Swedish crystalline rocks.
SKB Arbetsrapport 88-37

14-7 Svensson U 1988
Numerical simulations of seawater intrusion in fractured porous media.
SKB Progress Report 25-88-09

14-8 Andersson J 1988
Application of discrete fracture network models at site characterization and safety analyses.
SKB Arbetsrapport 88-35

14-9 Henkel H 1988
Tectonic studies in the Lansjärv region.
SKB Technical Report 88-07

14-10 Lagerbäck R 1988
Postglacial faulting and paleoseismicity in the Lansjärv area, northern Sweden.
SKB Technical Report 88-25

14-11 Wahlström R 1988
Near-distance seismological monitoring of the Lansjärv neotectonic fault region.
SKB Technical Report 88-12

14-12 Barton N, Chryssanthakis P and Monsen K 1988
Validation of MUDEC against Colorado School of Mines block test data.
SKB Technical Report 88-14

14-13 Stephansson O and Savilahti T 1988
Validation of rock mechanics HNFEMP code against Colorado School Mines block test data.
SKB Technical Report 88-13

14-14 Christiansson R 1989
Bergspänningsmätning genom överborrning – fördelar och begränsningar. Bergmekanikdagen 1989.
Stiftelsen BeFo, Stockholm

14-15 Lindbom B, Lundblad K and Winberg A 1989
Parameter variations of the groundwater flow modelling at the Klipperås site; Regional and subregional scale.
SKB Arbetsrapport 89-05

14-16 Röshoff K 1989
Characterization of the morphology, basement rock and tectonics in Sweden.
SKB Technical Report 89-03

14-17 SKB Annual Report 1987
SKB Technical Report 87-33

CHAPTER 16

16-1 Laaksoharju M 1988
Shallow groundwater chemistry at Laxemar, Äspö and Ävrö.
SKB Progress Report 25-88-04

16-2 Laaksoharju M and Nilsson A-C 1989
Models of groundwater composition and of hydraulic conditions based on chemometrical and chemical analyses of deep groundwater at Äspö and Laxemar.
SKB Progress Report 25-89-04

- 16-3 Smellie S, Hålenius U, Tullborg E-L, MacKenzie A and Scott R**
1989
Isotopic and Mössbauer studies of a single conducting fracture in crystalline rock.
SKB Arbetsrapport 89-14
- 16-4 Riglet Ch, Vitorge P and Grenthe I**
1987
Standard potentials of the ($\text{MO}_2^{2+}/\text{MO}_2^+$)-systems for uranium and other actinides.
Inorganica Chimica Acta, 133(1987)323-329
- 16-5 Grenthe I, Bidoglio G and Omenetto N**
1988
Use of thermal lensing spectrophotometry (TLS) for the study of mononuclear hydrolysis of uranium(IV).
Inorganic Chemistry 28(1989)71-74
- 16-6 Puigdoménech I and Bruno J**
1988
Modelling uranium solubilities in aqueous solutions: validation of a thermodynamic data base for the EQ3/6 geochemical codes.
SKB Technical Report 88-21
- 16-7 Marinsky J A, Reddy M M, Ephraim J and Mathuthu A**
1988
Ion binding by humic and fulvic acids: A computational procedure based on functional site heterogeneity and the physical chemistry of polyelectrolyte solutions.
SKB Technical Report 88-04
- 16-8 Pedersen K**
1988
Preliminary investigations of deep groundwater microbiology in Swedish granitic rock.
SKB Technical Report 88-01
- 16-9 Eriksen T, Christensen H and Bjergbakke E**
1988
Radiolysis of groundwater: Influence of carbonate and chloride on the hydrogen peroxide production.
SKB Technical Report 88-22
- 16-10 Eriksen T and Ndalamba P**
1988
On the formation of a moving redox front by alpha radiolysis of compacted water saturated bentonite.
SKB Technical Report 88-27
- 16-11 Fritz B, Madé B and Tardy F**
1988
Geochemical modelling of the evolution of a granite/concrete/water-system around a repository for spent nuclear fuel.
SKB Technical Report 88-18
- 16-12 Moreno L, Tsang Y W, Tsang C F and Neretnieks I**
1988
Flow and solute transport in a single fracture. A two-dimensional statistical model.
SKB Technical Report 88-03
- 16-13 Zhu M**
January 1988
Some aspects of modelling of the migration of chemical species in groundwater systems.
Licentiate Theses, Royal Institute of Technology, Stockholm
- 16-14 Zhu M, Rasmusson A and Neretnieks I**
July 1988
Annual report on chemistry and chemical transport.
Report to SKB
- 16-15 Eriksen T**
1988
Radionuclide transport in a single fissure. A laboratory flow system for transport under reducing conditions.
SKB Technical Report 88-28
- 16-16 Birgersson L and Neretnieks I**
1988
Diffusion in the matrix of granitic rock. Field test in the Stripa mine. Final Report.
SKB Technical Report 88-08
- 16-17 Gustafsson E, Andersson P, Eriksson C-O and Nordqvist R**
1989
Radially converging tracer experiment in a low-angle fracture zone at the Finnsjön site, central Sweden.
SKB Arbetsrapport 88-39

CHAPTER 19

- 19-1 Poços de Caldas, Feasibility Study, Final Report (June 1986 – May 1987)**
SKB, Stockholm, 1987

19-2 Poços de Caldas, Second Year Final Report, Second Annual Report, (June 1987 – May 1988)
SKB, Stockholm, 1988

19-3 Miekeley N, Jesus H, da Silveira C and Kuechler I
1988

Colloid investigations in the Poços de Caldas natural analogue project. In Scientific Basis for Nuclear Waste Management 12. Material Research Society Meeting in Berlin.
(In press)

19-4 Smellie J, Chapman N, McKinley I, Penna Franca E and Shea M
1988

Testing safety assessment models using natural analogues in high natural-series groundwaters.
Ibid (in press)

19-5 West J, Vialta A and McKinley I
1988

The influence of microbial activity on the movement of uranium in the Osamu Utsumi mine.
Ibid (in press)

19-6 Smellie J
1988

Poços de Caldas, Minas Gerais, Brazil. A natural analogue study. Presented at the Third CEC Natural Analogue Working Group (NAWG) Meeting, held at Snowbird, Utah, June 15–17.

SKB ANNUAL REPORT 1988

Part III

Appendices

CONTENTS OF PART III

	Page
Appendix	
1 Organization Charts for SKB and Its Divisions	111
2 Lectures and Publications 1988	113
3 List of SKB Annual Reports 1977–1987	117
4 List of SKB Technical Reports 1988	119
5 Authors of SKB Technical Reports 1988 in Alphabetical Order	123

ORGANIZATION CHARTS FOR SKB AND ITS DIVISIONS

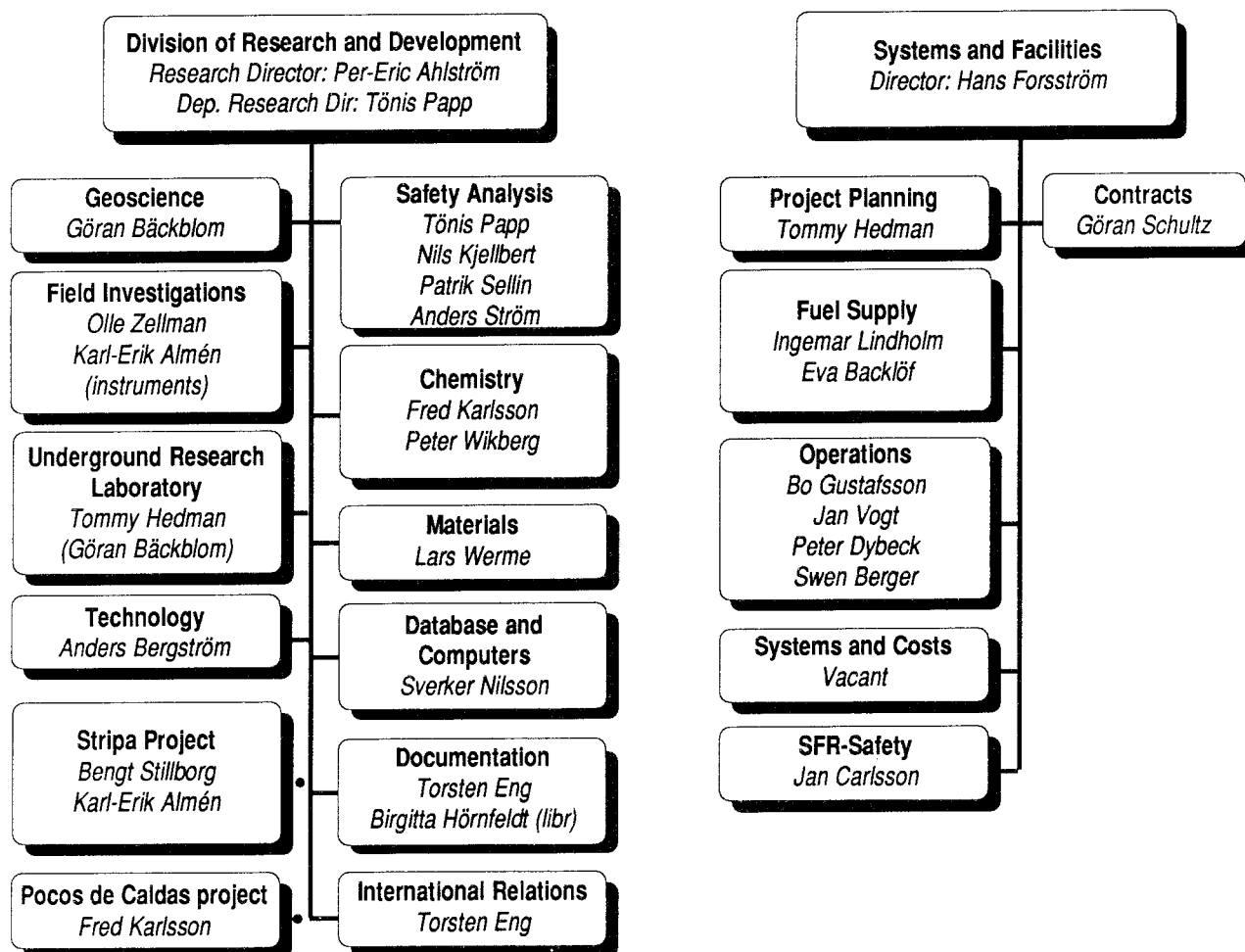
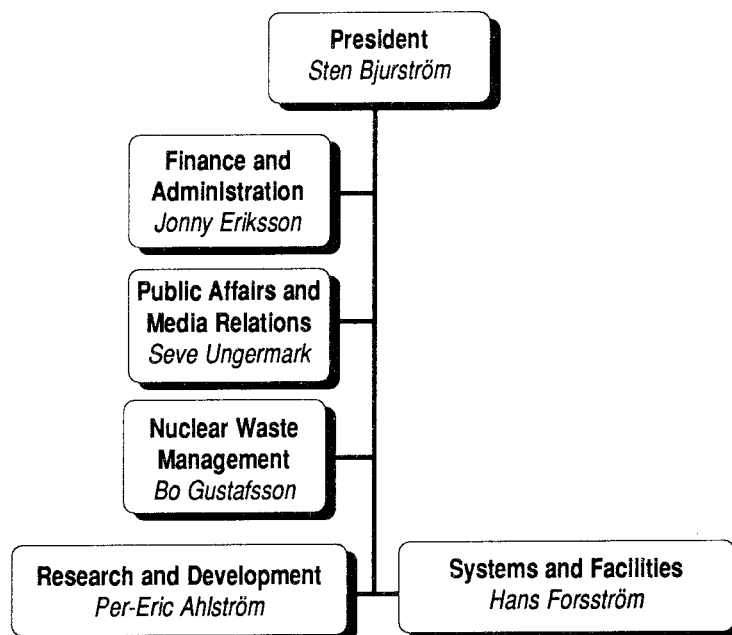

LECTURES AND PUBLICATIONS 1988

Results of some large scale in situ tracer experiments in a drift at the Stripa mine

Abelin H, Birgersson J, Gidlund L, Moreno L, Ågren T, Widén H, Neretnieks I

Paper presented at International Conference on Fluid Flow in Fractured Rocks, Atlanta, Georgia
1988-05-15-18

Sammanställning av olika bergarters vattenförande egenskaper baserade på undersökningar för lagring av kärnavfall

Ahlbom K, Carlsson L

Symposium om grundvattenförsörjning, geohydrologi i praktiken.
VIAK AB och Svenska Hydrologiska Rådet
1988-05-04

Site characterization activities at Stripa and other Swedish projects

Ahlström P-E

Radioactive Waste Management and the Nuclear Fuel Cycle, Vol. 9(5), pp. 19-32. The paper was also given at ANS Annual Meeting in San Diego
1988-06-12-16

Validation of the computer code MUDEC against the Colorado School of Mines block test data

Barton N, Chryssantakis P, Monsen K

BeFo Bergmekanikdagen, Stockholm
1988-03-16

New developments in hydrofracturing stress measurements at Luleå University of Technology

Bjarnason, B Ljunggren C, Stephansson O

Proceedings 2nd Int. Workshop on Hydraulic Fracturing Stress Measurements, Minnesota, pp. 113-140
1988-06-15-18

Mechanical Properties of dense Ca-smectite clay

Börjesson L, Broc D, Plas F

OECD/NEA Workshop on artificial clay barriers for high level radioactive waste repositories, Lund

Rheological properties of Na-smectite gels used for rock sealing

Börjesson L, Fredriksson A

OECD/NEA Workshop on artificial clay barriers for high level radioactive waste repositories, Lund

Gas migration from low-level radioactive waste repositories in hard rock

Braester Carol, Thunvik Roger

Nuclear Technology, Vol 82
July 1988

Site investigations for the Swedish undersea repository for reactor waste

Carlsson A, Christiansson R

ISRM Symposium on Rock Mechanics and Power Plants, Madrid
1988-09-12-16

The Swedish final repository for reactor waste.**Part I: Hydraulic testing and characterization of the bedrock**

Carlsson L, Winberg A, Arnefors J

International Symposium on Hydrogeology and Safety of Radioactive and Industrial Hazardous Waste Disposal
Orleans
1988-06-7-9

Fracture mapping on outcrops in crystalline bedrock: A case study within the subcambrian peneplain, southern Sweden

Ericsson L O, Ronge B S H

29th U.S. Symposium on Key Questions in Rock Mechanics,
University of Minnesota, Minneapolis
1988-06-13-15

The SGAB borehole radar – applications of a new technique (in Swedish)

Falk L

BeFo Bergmekanikdagen, Stockholm
1988-03-16

- Facilities and planning in Sweden**
Forsström H, Papp T
 Atomwirtschaft
 March 1988
- Preliminary study of spent UO₂ fuel corrosion in the presence of Bentonite**
Forsyth R S, Werne L O, Bruno J
 Journal of Nuclear Materials 160 (1988) pp 218-223
- 3-D fault zone patterns in the Lansjärv study area**
Henkel Herbert
 The Lejondahl Symposium on Neotectonics
 September 5-6, 1988
- Magnetic patterns associated with regional shear zones**
Henkel Herbert
 Paper presented at a Nordic Geophysicist meeting, XVII NOFTIG, Uppsala
 January 1989
- World uranium resources, production and demand**
Lindholm I
 Proceedings from an IAEA Technical Committee Meeting on uranium deposits in Asia and the Pacific: Geology and exploration
 IAEA-TC-543/1
 1988
- Experimental geochemical exploration programme in Sumatera**
Magnusson J, Lindholm I
 Proceedings from an IAEA Technical Committee Meeting on uranium deposits in Asia and the Pacific: Geology and exploration
 IAEA-TC-543/21
 1988
- Stress migration in the north Atlantic and intraplate seismicity in Scandinavia – a proposal**
Meyer K, Olsson R, Scherman S
 Tectonophysics, 156(1988), pp 175-178
- Channeling in fractured zones and its potential impact on the transport of radionuclides**
Moreno L, Neretnieks I
 Presented in "Scientific basis for nuclear waste management XI", Berlin
 1988-10-10-13
- Some anomalous features of flow and solute transport arising from fracture aperture variability**
Moreno L, Tsang C F, Tsang Y W, Neretnieks I
 Submitted to Water Resour. Res.
 December 1988
- Flow and tracer transport in a single fracture: A stochastic model and its relation to some field observations**
Moreno L, Tsang Y W, Tsang C F, Hale F V, Neretnieks I
 Water Resour. Res., 24, 2033-2048
 1988
- Fracture characterization in crystalline rock by borehole radar**
Olsson O, Andersson P, Carlsten S, Falk L, Niva B, Sandberg S
 Workshop on ground penetrating radar, Ottawa
 1988-05-24-26
- Borehole radar applied to site investigations prior to tunneling**
Olsson O, Carlsten S, Falk L, Niva B, Sandberg E
 Tunneling '88, London
 1988-04-18-22
- Three-dimensional interpretation of fracture zones using borehole data**
Olsson O, Falk L, Sandberg S
 EAEG, The Hague
 June 1988
- Natural analogues in SKB safety assessments**
Papp T
 CEC Natural Analogue Working Group, Third meeting, Snowbird,
 Salt Lake City, USA, CEC Report EUR 11725 EN
- Pilot field experiment with Canister-embedding clay under simulated repository conditions**
Pusch R, Atabek R, Lajudie A, Lechelle J
 OECD/NEA Workshop on artificial clay barriers for high level radioactive waste repositories, Lund
- Alteration of the conductivity of rock from excavations as indicated by the Stripa plugging and backfilling tests**
Pusch R, Bergström A
 OECD/NEA Workshop on excavation effects, Winnipeg

Electron microscope examination of hydrothermally treated Bentonite clay

Pusch R, Güven N

OECD/NEA Workshop on artificial clay barriers for high level radioactive waste repositories, Lund

Basic model of water and gas flow through smectite clay buffers

Pusch R, Hökmark H

OECD/NEA Workshop on artificial clay barriers for high level radioactive waste repositories, Lund

Heat effects on soft Na Bentonite clay gels

Pusch R, Touret O

GFF, Vol. 110, Pt. 2

Contribution to: Sealing of underground repositories for radioactive wastes

Pusch R (as a member of a review group)

IAEA, Vienna

Alteration of the hydraulic conductivity of rock by tunnel excavation

Push R

J. Rock Mech. Min. Sci. & Geomech. Abstr. Vol. 26, No 1

Poços de Caldas, Minas Gerais, Brazil; A natural analogue study

Smellie J A T

CEC Natural Analogue Working Group, Third meeting, Snowbird, Salt Lake City, USA, CEC Report EUR 11725 EN

1988-06-15-17

Some Swedish natural analogue studies: A review

Smellie J A T

CEC Natural Analogue Working Group, Third meeting, Snowbird, Salt Lake City, USA, CEC Report EUR 11725 EN

1988-06-15-17

Stress measurements and modelling of crustal rock mechanics in Fennoscandia

Stephansson O

Proceedings NATO Advanced Research Workshop on Causes and Effects of Earthquakes at Passive Margins and in Areas with Postglacial Rebound on Both Sides of the North Atlantic, Vordingborg, Denmark, pp. 213-229

1988-05-09-13

Ga old thrust and Precambrian low angle faults; their implications for Caledonian tectonics

Tirén S A

Paper presented at GFF spring meeting

1988-05-19-20

Block faulting in southeastern Sweden interpreted from digital terrain models

Tirén S A, Beckholmen M

Paper presented at GFF spring meeting

1988-05-19-20

Flow and tracer transport in fractured media – A variable-aperture channel model and its properties

Tsang Y W, Tsang C F, Neretnieks I, Moreno L

Water Resour. Res., 24, 2049-2060

1988

Earthquake dynamics and seismotronics in the Baltic Shield

Wahlström R

GFF 110(1988), pp 422-425

LIST OF SKB ANNUAL REPORTS 1977 – 1987

1977-78

TR 121

KBS Technical Reports 1–120

Summaries.

Stockholm, May 1979

1979

TR 79-28

The KBS Annual Report 1979

KBS Technical Reports 79-01–79-27.

Summaries.

Stockholm, March 1980

1980

TR 80-26

The KBS Annual Report 1980

KBS Technical Reports 80-01 – 80-25.

Summaries.

Stockholm, March 1981

1981

TR 81-17

The KBS Annual Report 1981

KBS Technical Reports 81-01–81-16.

Summaries.

Stockholm, April 1982

1982

TR 82-28

The KBS Annual Report 1982

KBS Technical Reports 82-01–82-27.

Summaries.

Stockholm, July 1983

1983

TR 83-77

The KBS Annual Report 1983

KBS Technical Reports 83-01–83-76.

Summaries.

Stockholm, June 1984

1984

TR 85-01

Annual Research and Development Report 1984

Including Summaries of Technical Reports Issued during 1984. (Technical Reports 84-01 – 84-19)

Stockholm, June 1985

1985

TR 85-20

Annual Research and Development Report 1985

Including Summaries of Technical Reports Issued during 1985. (Technical Reports 85-01 – 85-19)

Stockholm, May 1986

1986

TR 86-31

SKB Annual Report 1986

Including Summaries of Technical Reports Issued during 1986

Stockholm, May 1987

1987

TR 87-33

SKB Annual Report 1987

Including Summaries of Technical Reports Issued during 1987

Stockholm, May 1988

LIST OF SKB TECHNICAL REPORTS 1988

1988

TR 88-01

Preliminary investigations of deep ground water microbiology in Swedish granitic rocks

Karsten Pedersen

University of Göteborg

December 1987

TR 88-02

Migration of the fission products strontium, technetium, iodine, cesium and the actinides neptunium, plutonium, americium in granitic rock

Thomas Ittner¹, Börje Torstenfelt¹, Bert Allard²

1 Chalmers University of Technology

2 University of Linköping

January 1988

TR 88-03

Flow and solute transport in a single fracture. A two-dimensional statistical model

Luis Moreno¹, Yvonne Tsang², Chin Fu Tsang², Ivars Neretnieks¹

1 Royal Institute of Technology, Stockholm, Sweden

2 Lawrence Berkeley Laboratory, Berkeley, CA, USA

January 1988

TR 88-04

Ion binding by humic and fulvic acids:

A computational procedure based on functional site heterogeneity and the physical chemistry of poly-electrolyte solutions

J A Marinsky¹, M M Reddy¹, J Ephraim², A Mathhuthu³

1 US Geological Survey, Lakewood, CA, USA

2 Linköping University, Linköping

3 State University of New York at Buffalo, Buffalo, NY, USA

April 1987

TR 88-05

Description of geophysical data on the SKB database GEOTAB

Stefan Sehlstedt

SGAB, Luleå

February 1988

TR 88-06

Description of geolocial data in SKBs database GEOTAB

Tomas Stark

Swedish Geological Co, Luleå

April 1988

TR 88-07

Tectonic studies in the Lansjärv region

Herbert Henkel

Swedish Geological Survey, Uppsala

October 1987

TR 88-08

Diffusion in the matrix of granitic rock. Field test in the Stripa mine. Final report.

Lars Birgersson, Ivars Neretnieks

Royal Institute of Technology, Stockholm

April 1988

TR 88-09

The kinetics of pitting corrosion of carbon steel. Progress report to June 1987

G P Marsh, K J Taylor, Z Sooi

Materials Development Division

Harwell Laboratory

February 1988

TR 88-10

GWHRT – A flow model for coupled groundwater and heat flow. Version 1.0

Roger Thunvik¹, Carol Braester²

1 Royal Institute of Technology, Stockholm

2 Israel Institute of Technology, Haifa

April 1988

TR 88-11

Groundwater numerical modelling of the Fjällveden study site – Evaluation of parameter variations

A hydrocoin study – Level 3, case 5A

Nils Åke Larsson¹, Anders Markström²

1 Swedish Geological Company, Uppsala

2 Kemakta Consultants Co, Stockholm

October 1987

TR 88-12

Near-distance seismological monitoring of the Lansjärv neotectonic fault region

Rutger Wahlström, Sven-Olof Linder, Conny Holmqvist

Seismological Department, Uppsala University, Uppsala

May 1988

- TR 88-13
Validation of the rock mechanics HNFEMP code against Colorado school of mines block test data
Ove Stephansson, Tomas Savilahti
 University of Luleå, Luleå
 May 1988
- TR 88-14
Validation of MUDEC against Colorado school of mines block test data
Nick Barton, Panayiotis Chryssanthakis, Karstein Monsen
 Norges Geotekniske Institutt, Oslo, Norge
 April 1988
- TR 88-15
Hydrothermal effects on montmorillonite A preliminary study
Roland Pusch
 Ola Karnland
 June 1988
- TR 88-16
Swedish Hard Rock Laboratory First evaluation of preinvestigations 1986–87 and target area characterization
Gunnar Gustafson, Roy Stanfors, Peter Wikberg
 June 1988
- TR 88-17
On the corrosion of copper in pure water
T E Eriksen¹, P Ndalamba¹, I Grenthe²
 1 The Royal Institute of Technology, Stockholm
 Department of nuclear chemistry
 2 The Royal Institute of Technology, Stockholm
 Department of inorganic chemistry
 March 1988
- TR 88-18
Geochemical modelling of the evolution of a granite-concrete-water system around a repository for spent nuclear fuel
Bertrand Fritz, Benoit Madé, Yves Tardy
 Université Louis Pasteur de Strasbourg
 April 1988
- TR 88-19
A Bayesian nonparametric estimation of distributions and quantiles
Kurt Pörn
 Studsvik AB
 November 1988
- TR 88-20
Creep properties of welded joints in OFHC copper for nuclear waste containment
Bo Ivarsson, Jan-Olof Österberg
 Swedish Institute for Metals Research
 August 1988
- TR 88-21
Modelling uranium solubilities in aqueous solutions: Validation of a thermodynamic data base for the EQ3/6 geochemical codes
I Puigdomènech¹, J Bruno²
 1 Studsvik Nuclear, Nyköping
 Environmental Services
 2 Royal Institute of Technology, Stockholm
 Department of Inorganic Chemistry
 October 1988
- TR 88-22
Radiolysis of ground water: influence of carbonate and chloride on the hydrogen peroxide production
T E Eriksen¹, P Ndalamba², H Christensen², E Bjerbakke³
 1 The Royal Institute of Technology, Department of Nuclear Chemistry, S-100 44 Stockholm, Sweden
 2 Studsvik Energiteknik AB, S-611 82 NYKÖPING, Sweden
 3 Risø National Laboratory, DK-4000 Roskilde, Denmark
 December 1988
- TR 88-23
Source parameters of major earthquakes near Kiruna, northern Sweden, deduced from synthetic seismogram computation
W T Kim, E Skordas, Y P Zohu, O Kulhanek
 Seismological Department, Uppsala University,
 Box 120 19, S-750 12 UPPSALA
 June 1988
- TR 88-24
Fission product concentration profiles (Sr, Xe, Cs and Nd) at the individual grain level in power-ramped LWR fuel
R S Forsyth, O Mattsson, D Schrire
 Studsvik Nuclear, Nyköping
 December 1988
- TR 88-25
Postglacial faulting and paleoseismicity in the Lansjärv area, northern Sweden
Robert Lagerbäck
 October 1988

TR-88-26

Geological evidence of smectite longevity

The Sardinian and Gotland cases

Roland Pusch, Ola Karnland

December 1988

TR-88-27

On the formation of a moving redox-front by α -radiolysis of compacted water saturated bentonite

Trygve E Eriksen, Pierre Ndalamba

The Royal Institute of Technology

Department of Nuclear Chemistry

December 1988

TR-88-28

Radionuclide transport in a single fissure

A laboratory flow system for transport under reducing conditions

Trygve E Eriksen

The Royal Institute of Technology

Department of Nuclear Chemistry

December 1988

TR 88-29

Modelling of buffer material behaviour

Some examples of material models and performance calculations

Lennart Børgesson

Clay Technology AB, Lund, Sweden

December 1988

TR 88-30

Rheological properties of sodium smectite clay

Lennart Børgesson, Harald Hökmark, Ola Karnland

Clay Technology AB, Lund, Sweden

December 1988

TR 88-31

Long-term dynamics of a lake ecosystem and the implications for radiation exposure

Björn Sundblad, Ulla Bergström, Sverker Evans,

Ignasi Puigdomènech

Studsvik Nuclear, Nyköping, Sweden

September 1988

AUTHORS OF SKB TECHNICAL REPORTS 1988 IN ALPHABETICAL ORDER

AUTHOR	TECHNICAL REPORT NO	AUTHOR	TECHNICAL REPORT NO
<i>Allard, Bertil</i> University of Linköping, Dept. of Water in Env. and Society	02	<i>Ittner, Thomas</i> Chalmers University of Technology, Dept. of Nuclear Chemistry	02
<i>Barton, Nick</i> Norges Geotekniske Institutt, Oslo	14	<i>Ivarsson, Bo</i> Swedish Institute for Metals Research	20
<i>Bergström, Ulla</i> Studsvik Nuclear	31	<i>Karnland, Ola</i> Clay Technology, Lund	15, 26, 30
<i>Birgersson, Lars</i> Royal Institute of Technology, Dept. of Chemical Engineering	08	<i>Kim, W Y</i> University of Uppsala, Seismological Dept	23
<i>Bjergbakke, E</i> Risö National Laboratory, Roskilde	22	<i>Kulhanek, O</i> University of Uppsala, Seismological Dept	23
<i>Börgesson, Lennart</i> Clay Technology AB	29, 30	<i>Lagerbäck, Robert</i>	25
<i>Braester, Carol</i> Israel Institute of Technology, Haifa	10	<i>Larsson, Nils-Åke</i> Swedish Geological Co, Uppsala	11
<i>Bruno, J</i> Royal Institute of Technology, Dept. of Inorganic Chemistry	21	<i>Linder, Sven-Olof</i> University of Uppsala, Seismological Dept.	12
<i>Christensen, H</i> Studsvik Nuclear	22	<i>Madé, Benoit</i> Université Louis Pasteur de Strasbourg, France	18
<i>Chryssanthakis, Panayiotis</i> Norges Geotekniske Institutt, Oslo	14	<i>Marinsky, J A</i> US Geological Survey, Denver Federal Center, Lakewood	04
<i>Ephraim, J</i> University of Linköping, Dept. of Water in Env. and Society	04	<i>Markström, Anders</i> Kemakta Consultants Co, Stockholm	11
<i>Eriksen, Trygve E</i> Royal Institute of Technology, Dept of Nuclear Chemistry	17, 22, 27, 28	<i>Marsh, G P</i> Harwell Laboratory, Materials Develop- ment Division	09
<i>Evans, Sverker</i> Studsvik Nuclear	31	<i>Mathuthu, A</i> State University of New York at Buffalo, Dept. of Chemistry	04
<i>Forsyth, R S</i> Studsvik Nuclear	24	<i>Mattsson, O</i> Studsvik Nuclear	24
<i>Fritz, Bertrand</i> Université Louis Pasteur de Stras- bourg, France	18	<i>Monsen, Karstein</i> Norges Geotekniske Institutt, Oslo	14
<i>Grenthe, I</i> Royal Institute of Technology, Dept. of Inorganic Chemistry	17	<i>Moreno, Luis</i> Royal Inst. of Technology, Dept. of Chemical Engineering	03
<i>Gustafson, Gunnar</i> VIAK AB	16	<i>Ndalamba, Pierre</i> Royal Institute of Technology, Dept. of Nuclear Chemistry	17, 22, 27
<i>Henkel, Herbert</i> Swedish Geological Survey	07	<i>Neretnieks, Ivars</i> Royal Inst. of Technology, Dept. of Chemical Engineering	03, 08
<i>Hökmark, Harald</i> Clay Technology AB	30		
<i>Holmqvist, Conny</i> University of Uppsala, Seismological Dept.	12		

AUTHOR	TECHNICAL REPORT NO	AUTHOR	TECHNICAL REPORT NO
<i>Pedersen, Karsten</i> University of Gothenburg, Dept of Marine Microbiology	01	<i>Stephansson, Ove</i> University of Luleå	13
<i>Pörn, Kurt</i> Studsvik AB	19	<i>Sundblad, Björn</i> Studsvik Nuclear	31
<i>Puigdomènech, I</i> Studsvik Nuclear, Environmental Services	21, 31	<i>Tardy, Yves</i> Université Louis Pasteur de Strasbourg, France	18
<i>Pusch, Roland</i> Clay Technology, Lund	15, 26	<i>Taylor, K J</i> Harwell Laboratory, Materials Development Division	09
<i>Reddy, M M</i> US Geological Survey, Denver Federal Center, Lakewood	04	<i>Thunvik, Roger</i> Royal Institute of Technology	10
<i>Savilahti, Tomas</i> University of Luleå	13	<i>Torstenfeldt, Börje</i> Chalmers University of Technology, Dept. of Nuclear Chemistry	02
<i>Schrire, D</i> Studsvik Nuclear	24	<i>Tsang, Yvonne</i> Earth Science Div., Lawrence Berkeley Laboratory	03
<i>Sehlstedt, Stefan</i> Swedish Geological Co	05	<i>Tsang, Chin Fu</i> Earth Science Div., Lawrence Berkeley Laboratory	03
<i>Skordas, E</i> University of Uppsala, Seismological Dept.	23	<i>Wahlström, Rutger</i> University of Uppsala, Seismological Dept.	12
<i>Sooi, Z</i> Harwell Laboratory, Materials Develop- ment Division	09	<i>Wikberg, Peter</i>	16
<i>Stanfors, Roy</i> Roy Stanfors Consulting AB	16	<i>Zhou, Y P</i> University of Uppsala, Seismological Dept.	23
<i>Stark, Tomas</i> Swedish Geological Co, Luleå	06	<i>Österberg, Jan-Olof</i> Swedish Institute for Metals Research	20

SKB ANNUAL REPORT 1988

Part IV

**Summaries of Technical Reports
Issued During 1988**

**PRELIMINARY INVESTIGATIONS OF DEEP
GROUND WATER MICROBIOLOGY IN SWEDISH
GRANITIC ROCK**

Karsten Pedersen

University of Göteborg, Department of Marine Micro-
biology, Gothenburg

December 1987

ABSTRACT

The intention with this study was to collect data that can support the planning of a project over the eventual impact between microbes and a Swedish HLW repository. The total numbers of bacteria, the numbers of aerobic and anaerobic bacteria and the most probable numbers of Thiobacilli and related bacteria were determined in three different boreholes at different levels. The highest total numbers of bacteria were registered in the EVO1 borehole close to the Simpevarp nuclear power plants and were between 10^5 and 10^6 bacteria/ml. The higher of these two numbers refer to samples taken with a gas sampler. The gas sampler also gave the highest number of aerobic and anaerobic bacteria. The results presented here point out the gas sampler as being the sample site that gives the safest data describing the aquifer conditions with respect to microbiology. The first task that needs to be solved by a coming project is judged to be collection of data on numbers, species and activity of deep ground water microbial populations in Swedish granitic rocks.

**MIGRATION OF THE FISSION PRODUCTS
STRONTIUM, TECHNETIUM, IODINE, CESIUM
AND THE ACTINIDES NEPTUNIUM, PLUTO-
NIUM, AMERICIUM IN GRANITIC ROCK**

Thomas Ittner,¹⁾ Börje Torstenfelt¹⁾ and Bertil Allard²⁾

¹⁾Department of Nuclear Chemistry, Chalmers Uni-
versity of Technology, Gothenburg

²⁾Department of Water in Environment and Society,
University of Linköping, Linköping

January 1988

ABSTRACT

The migration of the fission products strontium, tech-
netium, iodine and cesium and the actinides neptunium,
plutonium and americium in granitic rock has been
studied.

Rock samples were taken from drilling cores in
granitic and granodioritic rock, and small (2x2x2 cm)
rock tablets from the drilling cores were exposed to a
groundwater solution containing one of the studied ele-
ments at trace levels. The concentration of the element
versus penetration depth in the rock tablet was mea-
sured radiometrically. The sorption on the mineral
faces and the migration into the rock was studied, by an
autoradiographic technique.

The cationic fission products strontium and cesium
had apparent diffusivities of $10^{-13} - 10^{-14}$ m²/s. They
migrate mainly in fissures or filled fractures containing
e.g., calcite, epidote or chlorite or in veins with high
capacity minerals (e.g. biotite).

The anionic fission products iodine and technetium
had apparent diffusivities of about 10^{-14} m²/s. These
species migrate along mineral boundaries and in open
fractures and to a minor extent in high capacity mineral
veins.

The migration of the actinides neptunium, plutonium
and americium is very slow (in the mm-range after 2-3
years contact time). The apparent diffusivities were
about 10^{-15} m²/s. The actinide migration into the rock
was largely confined to fissures.

FLOW AND SOLUTE TRANSPORT IN A SINGLE FRACTURE. A TWO-DIMENSIONAL STATISTICAL MODEL

Luis Moreno¹⁾; Yvonne Tsang²⁾; Chin Fu Tsang²⁾ and Ivars Neretnieks¹⁾

¹⁾Department of Chemical Engineering, Royal Institute of Technology

²⁾Earth Sciences Division, Lawrence Berkeley Laboratory, University of California, Berkeley, California

January 1988

ABSTRACT

A two-dimensional model for a single fracture with variable apertures is presented. The spatial variation of the apertures in the fracture is defined by the aperture density distribution and the spatial correlation length. Flow and solute transport in the generated fractures are simulated. The simulated flow is unevenly distributed in the fracture and the flowrates may vary by several orders of magnitude. Cubic law fracture apertures are also calculated and are smaller than the mass balance fracture apertures. The pressure field in the fracture is calculated, in which great differences exist between this pressure and the pressure field for a fracture with constant aperture. The solute transport is studied using the particle tracking technique. Breakthrough curves for nonsorbing and sorbing species are simulated. The sensitivity of the two-dimensional model is studied by generating fractures with different parameters in the density distribution function, different correlation lengths, and different number of nodes used in one correlation length.

The flow is strongly reduced when the simulated normal stress is increased. The cubic law fracture aperture may be several orders of magnitude smaller than the mass balance fracture aperture.

ION BINDING BY HUMIC AND FULVIC ACIDS: A COMPUTATIONAL PROCEDURE BASED ON FUNCTIONAL SITE HETEROGENEITY AND THE PHYSICAL CHEMISTRY OF POLYELECTROLYTE SOLUTIONS

J A Marinsky¹⁾; M M Reddy¹⁾; J Ephraim²⁾ and A Mathuthu³⁾

¹⁾U S Geological Survey, Denver Federal Center, Lakewood, USA

²⁾Linköping University, Department of Water in Environment and Society, Linköping

³⁾Department of Chemistry, State University of New York at Buffalo, Buffalo, New York

April 1988

ABSTRACT

Ion binding equilibria for humic and fulvic acids are examined from the point of view of functional site heterogeneity and the physical chemistry of polyelectrolyte solutions. A detailed explanation of the potentiometric properties of synthetic polyelectrolytes and ion-exchange gels is presented first to provide the basis for a parallel consideration of the potentiometric properties exhibited by humic and fulvic acids. The treatment is then extended to account for functional site heterogeneity. Sample results are presented for analysis of the ion-binding reactions of a standard soil fulvic acid (Armada Horizons Bh) with this approach to test its capability for anticipation of metal ion removal from solution. The ultimate refined model is shown to be adaptable, after appropriate consideration of the heterogeneity and polyelectrolyte factors, to programming already available for the consideration of ion binding by inorganics in natural waters.

DESCRIPTION OF GEOPHYSICAL DATA ON THE SKB DATABASE GEOTAB*Stefan Sehlstedt*

Swedish Geological Co

February 1988

ABSTRACT

For the storage of different types of data collected by SKB a database called GEOTAB has been created. The following data is stored in the database:

- Background data
- Geological data
- Geophysical data
- Hydrogeological data
- Hydrochemical data

This report describes the data flow for different types of geophysical measurements. The descriptions start with measurements and end with the storage of data in GEOTAB. Each process and the resulting data volume is presented separately. The geophysical measurements have been divided into the following subjects.

- Geophysical ground surface measurements, profile measurements
- Geophysical ground surface measurements, grid net measurements
- Geophysical borehole logging
- Petrophysical measurements

Each group of measurements is described in an individual chapter. In each chapter several measuring techniques are described and each method has a data table and a flyleaf table in GEOTAB.

DESCRIPTION OF GEOLOGICAL DATA IN SKBS DATABASE GEOTAB*Tomas Stark*

Swedish Geological Co, Luleå

April 1988

ABSTRACT

Since 1977 the Swedish Nuclear Fuel and Waste Management Co, SKB, has been performing a research and development programme for final disposal of spent nuclear fuel. The purpose of the programme is to acquire knowledge and data of radioactive waste. Measurements for the characterisation of geological, geophysical, hydrogeological and hydrochemical conditions are performed in specific site investigations as well as for geoscientific projects.

Large data volumes have been produced since the start of the programme, both raw data and results. During the years these data were stored in various formats by the different institutions and companies that performed the investigations. It was therefore decided that all data from the research and development programme should be gathered in a database. The database, called GEOTAB, is a relational database. It is based on a concept from Mimer Information Systems, and have been further developed by Ergodata. The hardware is a VAX 750 computer located at KRAB (Kraftverksbolagens Redovisningsavdelning AB) in Stockholm.

The database comprises four main groups of data volumes. These are:

- Geological data
- Geophysical data
- Hydrogeological data
- Hydrochemical data

In the database, background information from the investigations and results are stored on-line on the VAX 750, while raw data are either stored on-line or on magnetic tapes.

This report deals with geological data and describes the dataflow from the measurements at the sites to the result tables in the database. All of the geological investigations were carried out by the Swedish Geological Survey, before 820701, and by Swedish Geological Co, SGAB, after that date.

The geological investigations have been divided into three categories, and each category is stored separately in the database.

They are:

- Surface Fractures
- Core Mapping
- Chemical Analyses

At SGU/SGAB the geological data were stored on-line on a PRIME 750 mini computer, on microcomputer floppy disks or in filed paper protocols. During 1987 the data files were transferred from SGAB to datafiles on the VAX computer. The data from the protocols were punched to data files either on the PRIME (before the transfer) or on the VAX. The flyleaves (tables containing background data) were also punched, transferred and loaded into the database.

In the following chapters the data flow of each of the three geological information categories are described separately.

SKB Technical Report No 88-07

TECTONIC STUDIES IN THE LANSJÄRV REGION

Herbert Henkel

Swedish Geological Survey

October 1987

ABSTRACT

This report contains the results and the analysis of ground geophysical measurements and the tectonic interpretation in the 150 x 200 km Lansjärv study area. It describes the data and methods used. The significance of strike slip fault patterns in relation to the surface morphology is discussed. The obtained results are used to suggest a tentative model for the present tectonic deformation. More data on actual deformations would however be necessary to confirm and enhance the model. The report is part of the bedrock stability programme of SKB. The major conclusions regarding the tectonic structures are:

- three regional fault systems are identified, two steep NW and N trending and a third NNE trending with gentle ESE dips,
- the steep fault systems have strike slip generated deformation patterns both in the Precambrian structures and in the surface morphology,

- the post-glacial faults of the area are part of this fault pattern and represent movements mainly on reactivated, gently dipping zones,
- several suspected late or post-glacial, fault related features are found along the steep NW and N faults.

Sites for drilling and geodetic networks for deformation measurements are suggested. Detailed background data are documented in additional 4 reports. The basic geophysical and geological datasets are documented in color plotted 1:250 000 maps. A tectonic interpretation map in the same scale has been produced by combined interpretation of magnetic, elevation, elevation relief and gravity data.

SKB Technical Report No 88-08

DIFFUSION IN THE MATRIX OF GRANITIC ROCK. FIELD TEST IN THE STRIPA MINE. FINAL REPORT

Lars Birgersson and Ivars Neretnieks

Royal Institute of Technology, Department of Chemical Engineering

April 1988

ABSTRACT

Three similar migration experiments in the matrix of granitic rock have been performed and are presented. The experiments have been carried out in "undisturbed" rock, that is rock under its natural stress environment. Since the experiments were performed at the 360 m level in the Stripa Mine (Stripa, Sweden) the rock was subjected to nearly the same conditions as the rock surrounding a nuclear waste repository as proposed in the Swedish concept (SKB) where the nuclear waste is to be stored in canisters at approximately 500 m depth in crystalline rock.

A mixture of three nonsorbing (conservative) tracers, Uranine, Cr-EDTA, and I⁻, were injected into the granitic rock matrix for three different time periods: about 3 months, about 6 months, and about 3.5 years. The subsequent overcorings of injection holes showed that the tracers had in some cases migrated at least about 400 mm (measuring limit) into the rock matrix for the experiment with the longest injection time. It could also be seen that there were large differences in migra-

tion distance into the rock matrix for samples taken fairly close to each other.

The results from all three experiments showed that all three tracers had migrated through the disturbed zone close to the injection hole, through the fissure coating material, and a distance into the "undisturbed" rock matrix.

These results therefore indicate that it is possible for dissolved compounds to migrate into the rock matrix. This migration into the rock matrix will permit the uptake of dissolved species in water flowing in fractures and will increase the area available for sorption of sorbing radionuclides significantly and therefore retard the radionuclides by order(s) of magnitude.

Diffusivities and hydraulic conductivities obtained in this in-situ experiment compare well with those obtained in laboratory experiments.

SKB Technical Report No 88-09

THE KINETICS OF PITTING CORROSION OF CARBON STEEL

G P Marsh; K J Taylor and Z Sooi

Materials Development Division, Harwell Laboratory

February 1988

ABSTRACT

The report describes progress between April 1986 and May 1987 in a programme studying the kinetics of pitting corrosion in carbon steel containers for the disposal of high level nuclear waste in a granitic repository.

Much of the effort during this period has been devoted to the development of an improved statistical method for analysing pit growth data to take account of the difference in area of laboratory specimens and full sized waste containers. Statistical analysis of data from pit growth experiments lasting 1218–1314h and 3240h with large area (460 cm²) plates of BS 4360 steel have indicated that the depth distributions correlate most closely with a limited distribution function. This contrasts with previous data with small specimens (8 cm²) of carbon 20 steel which gave a better correlation with an unlimited exponential distribution function. This difference may arise because the larger specimens give a more accurate sample of the pit depth distribution, particularly the "tail-off" at high pit depths which is crucial in determining the overall shape of the distribution. This

correlation of the pit depth data with a limited distribution implies that previous statistical analyses to estimate the maximum pit depths in full size containers, which were made using unlimited distribution functions, will be pessimistic.

An evaluation of the maximum feasible pitting period based on estimating the period during which the oxygen diffusion flux is sufficient to stabilise a passive film on carbon steel containers has indicated that this is of the order of 125 years rather than the full 1000 year container life. The estimate is sensitive to the value of the leakage current assumed to flow through the passive film, and therefore work is planned to measure this accurately in relevant granitic environments.

SKB Technical Report No 88-10

GWHRT – A FLOW MODEL FOR COUPLED GROUNDWATER AND HEAT FLOW. VERSION 1.0

Roger Thunvik¹⁾ and Carol Braester²⁾

¹⁾Royal Institute of Technology

²⁾Israel Institute of Technology, Haifa, Israel

April 1988

ABSTRACT

A mathematical model describing the hydrothermal conditions around a hard rock repository for disposal of nuclear fuel waste is presented. The model was developed to study the effect of heat released from a radioactive waste repository on the flow times from the repository to the ground surface. The model consists of a set of coupled non-linear partial differential equations for heat and ground water flow. In addition there are two equations of state relating fluid density and viscosity to pressure and temperature. The system of equations is solved numerically using the finite element method in one, two or three dimensions. The model has been successively developed and used as a research tool to include unsaturated flow, gas migration, discrete elements, stochastic analysis, etc. The model version described here is the basic one. The fractured rock is treated either as two overlapping continua in which the one represents the network of fractures and the other the solid blocks or as a single equivalent medium. The first approach assumes quasi-steady state heat transfer from the rock to the fluid, allowing a linear heat trans-

fer function to be used. The second approach assumes instantaneous equilibrium between the fluid and the rock.

SKB Technical Report No 88-11

GROUNDWATER NUMERICAL MODELLING OF THE FJÄLLVEDEN STUDY SITE – EVALUATION OF PARAMETER VARIATIONS. A HYDROCOIN STUDY – LEVEL 3, CASE 5A

*Nils-Åke Larsson*¹⁾ and *Anders Markström*²⁾

¹⁾Swedish Geological Company, Uppsala

²⁾Kemakta Consultants Co, Stockholm

October 1987

ABSTRACT

Level 3 of the HYDROCOIN project concerns the sensitivity and uncertainty analysis of groundwater flow calculations. In the present study the sensitivity/uncertainty of the hydraulic conductivity distribution in crystalline rocks is considered at the Fjällveden study site – a site included in the Swedish site selection programme for final storage of spent nuclear fuel. A three-dimensional FEM-model assuming steady-state flow with constant fluid properties under saturated conditions is used.

The bedrock of the site is divided into three hydraulic units; rock mass, local and regional fracture zones. The data set of hydraulic conductivity of each unit has been treated statistically in various ways, reflecting different aspects of the physical conditions of the site. A total of nine cases have been prepared, all based on 214 data points.

The calculated head distribution and flow pattern for the model cases differ very little, while the flow rates and residence times vary more significantly (2–3 times).

The results of each parameter analysed separate the model cases as expected: a hydraulic contrast between rock mass and fracture zones enhances the hydraulic gradient and flow rate, and decreases the quality of the numerical solution. Anisotropic hydraulic conductivity in the rock mass skews the head isopotentials to be more parallel with the main direction of the anisotropy, etc. However, the combined effect illustrated by the particle trajectories and residence times is not that easy to predict. The effect of anisotropy becomes significant

at depths greater than approx. 300–500 m as the head gradient from the groundwater table is flattened out.

Groundwater recharge as a measure of quality assurance of the model calculations at repository depth is of limited use as it primarily reflects the hydraulic conditions in the surficial bedrock.

Finally, for more site specific modelling in the future computers of greater capacity has to be used to overcome simplifications in the discretisation of the conceptual model.

SKB Technical Report No 88-12

NEAR-DISTANCE SEISMOLOGICAL MONITORING OF THE LANSJÄRV NEOTECTONIC FAULT REGION

Rutger Wahlström; Sven-Olof Linder and Conny Holmqvist

Seismological Department, Uppsala University

October 1987

ABSTRACT

During five months in 1987, a mobile seismic network comprising digital and analog units was operated along the Lansjärv neotectonic fault segments in Swedish Lapland. More than 20 local earthquakes, at distances less than 40 km from the stations, were recorded. Nine of these have been accurately located from high-resolution digital data, using a simple velocity model derived from test explosions recorded at the stations. Two events have well restrained focal depths, 8 and 9 km, respectively. Several earthquakes are located east of the postglacial faults and in the vicinity of major faults. However, derived focal mechanisms are poorly restrained and based on data (Pg-polarities and Sg/Pg-amplitude ratios) from too few stations to allow a solid seismotectonic interpretation. Based on Sg-wave amplitude spectra, computed seismic moments range from $5 \cdot 10^{10}$ to $1 \cdot 10^{12}$ Nm, fault radii 40 – 100 m, average relative displacements 0.07 – 8 mm, and stress drops 0.05 – 7 MPa. A future extended network would provide more information on the detailed seismotectonic characteristics of the region.

**VALIDATION OF THE ROCK MECHANICS
HNFEMP CODE AGAINST COLORADO SCHOOL
OF MINES BLOCK TEST DATA**

Ove Stephansson and Tomas Savilahti
University of Luleå

May 1988

ABSTRACT

In the determination of crustal response and farfield stability of a vault for radioactive waste, the rock mass may be modelled either as a discontinuous or as a continuous medium. In this report, we emphasize the "continuum" approach, where discontinuities like joints and faults are smeared out in the rock mass.

The purpose of this report is to validate the non-linear finite element code HNFEMP against the Colorado School of Mines (CSM) block test data at Edgar Mine, Idaho Springs, Colorado. Results from mapping field tests and successive analysis were used to define three different material models with different normal and shear stiffnesses. Altogether, 18 models of a block consisting of three sets of joints under uni-axial and bi-axial loading conditions were considered. The results from the numerical modelling were subsequently compared with the measured displacements, strains and stresses obtained from five field tests on the CSM block.

There is fair agreement in the orientations and magnitudes of the displacement vectors between the field test conducted by Richardson (1986), and the HNFEMP-modelling. Good quantitative agreement between the experimental and numerical results were obtained in the modulus of deformation from four corner measuring stations in the block. Using the stiffness values suggested by the Terra Tek research group, the overall block deformation modulus has been calculated and the numerical results are in close agreement with the data obtained from the block test. Monitoring of the principal horizontal stress by the USBM borehole deformation gage gave the best agreement with the applied loading and the numerical results.

Field test results have shown that the CSM block is larger than the critical size needed for an equivalent continuum approach. Modelling with the smeared out method and HNFEMP is therefore valid. The fair to good agreement between the field data and the modelling results at low stresses means that the model with three intersecting joints and a linear joint stiffnesses is a good representation of the CSM block.

**VALIDATION OF MUDEC AGAINST COLORADO
SCHOOL OF MINES BLOCK TEST DATA**

*Nick Barton; Panayiotis Chryssanthakis and
Karstein Monsen*

Norges Geotekniske Institutt, Oslo

April 1988

ABSTRACT

The objective of this study was to validate the discrete element codes MUDEC-linear and MUDEC (with the Barton – Bandis joint model) against a well controlled in situ test. The measured results obtained from the CSM block test by Terra Tek Inc., by Richardson and Brown (CSM) and Leijon (LUT) were compared with the numerical results. Equal biaxial, north-south and east-west uniaxial loading were applied to each type of model. The boundary conditions were varied from the simple uniform stress boundaries of the linear joint model to the more realistic fluid pressurized boundaries, simulating the flatjacks as rectangular slots. In addition, rigid boundaries prevented movement behind the flat-jacks.

Comparison of the numerical results with the stress measurements performed by Leijon and Brown, with Terra Tek's measurements of shear displacement, shear stiffness and conducting aperture, and with Richardson's measurements of displacement vectors and shear displacements showed generally a good agreement.

Excellent agreement was obtained for joint shear displacements and joint conductive apertures.

SKB Technical Report No 88-15

HYDROTHERMAL EFFECTS ON MONTMORILLONITE. A PRELIMINARY STUDY

Roland Pusch and Ola Karnland

Clay Technology, Lund

June 1988

ABSTRACT

Hydrothermal effects on montmorillonite clay are usually taken to have the form of conversion of this clay mineral to other species, such as illite, disregarding microstructural alteration and cementation caused by precipitation of silica and other compounds. The present report is focussed on identification of the primary processes that are involved in such alteration, the release of silica and the microstructural changes associated with heating being of major interest. In the first test phase, reported here, Na montmorillonite in distilled water was investigated by XRD, rheology tests and electron microscopy after heating to 60–225°C for 0.01 to 1 year.

The preliminary conclusions are that heating produces contraction of the particle network to form dense "branches", the effect being most obvious at the highest temperature but of significance even at 60–100°C. Release of substantial amounts of silica has been documented for temperatures exceeding 150°C and precipitation of silica was observed on cooling after the hydrothermal testing under the closed conditions that prevailed throughout the tests. The precipitates, which appeared to be amorphous and probably consisted of hydrous silica gels, were concluded to have increased the mechanical strength and caused some brittleness, particularly of the dense clays.

The nature of the silica release, which is assumed to be associated with beidellitization, maybe closely related to an unstable state of a certain fraction of tetrahedral silica at heat-induced transfer between two different crystal modes of montmorillonite.

SKB Technical Report No 88-16

SWEDISH HARD ROCK LABORATORY FIRST EVALUATION OF PREINVESTIGATIONS 1986–87 AND TARGET AREA CHARACTERIZATION

Gunnar Gustafson; Roy Stanfors and Peter Wikberg

June 1988

ABSTRACT

SKB plans to site an underground research laboratory in the Simpevarp area. A regional survey started in 1986 and an extensive programme for geology, geohydrology and hydrochemistry was carried through. This report gives an evaluation of all available data gathered from the start of the project up to the drilling of core boreholes in some target areas in the autumn of 1987. A descriptive geological-tectonic model on a regional scale is presented that is intended to constitute a basis for the hydrogeological modelling work. Preliminary rock mass descriptions are also presented on a more detailed scale for some minor parts of the area.

It is recommended that the island Äspö is the principal target area for the continued work on the Swedish Hard Rock Laboratory.

SKB Technical Report No 88-17

ON THE CORROSION OF COPPER IN PURE WATER

T E Eriksen¹⁾; P Ndalamba¹⁾ and I Grenthe²⁾

¹⁾Royal Institute of Technology, Department of Nuclear Chemistry

²⁾Royal Institute of Technology, Department of Inorganic Chemistry

March 1988

ABSTRACT

Due to a remarkable publication by Hultquist questioning well known thermodynamic data the corrosion of copper in distilled water has been studied. No hydrogen evolution was observed during an exposure period of 61

days using a gaschromatographic technique. Cu_2O was the only corrosion product detected by means of ESCA and cathodic reduction. The corrosion rates obtained for two different qualities are much lower than corrosion rate measured in the study by Hultquist and is ascribed to the reaction between the copper foils and rest oxygen initially present in the water. In conclusion the present investigation confirmed well established thermodynamics, which means that oxidation of copper by pure deoxygenated water under the formation of hydrogen as proposed by Hultquist is not thermodynamically feasible.

SKB Technical Report No 88-18

GEOCHEMICAL MODELLING OF THE EVOLUTION OF A GRANITE-CONCRETE-WATER SYSTEM AROUND A REPOSITORY FOR SPENT NUCLEAR FUEL

Bertrand Fritz; Benoit Madé and Yves Tardy

Université Louis Pasteur de Strasbourg, France

April 1988-04

ABSTRACT

The interactions between a granitic rock and concrete due to the natural solutions circulating around a repository for spent nuclear fuel has been simulated considering the dissolution of $\text{Ca}(\text{OH})_2$ as the major source of alkalinity due to the concrete. This study follows a previous one (SKB-Technical Report 84-10 by Fritz, Kam and Tardy, 1984) considering the same interaction without concrete at 25, 60 and 100°C. The temperature range has been extended to 150°C for both hypothesis (with or without $\text{Ca}(\text{OH})_2$).

The results of the modelling are considered as following:

- evolution of the water chemistry due to detected possible chemical reactions. (major chemical species, activities, pH, Eh, pCO_2 ...)
- minerals produced and dissolved.

The calculations give mass transfers and volumic consequences (opening or closing tendencies).

The conclusions of this yearly report are mainly the following:

- (1) the extent of the temperature range for the storage (up to 150°C) does not change the tendencies previously detected (Fritz et al., 1984) in the same

conditions without any particular alkaline effect due to concrete dissolution, the reactions occurring tend to decrease the porosity of the rock by a sealing effect due to calcite precipitation and clays formation.

- (2) The effect of an alkaline concrete dissolution is clearly important, pH may reach very high values in closed system (very low pCO_2), and the volumic consequence is found in favour of an opening of the porosity, at the stage of saturation of the portlandite.

This is probably an important point considering the security of natural barriers around such a repository.

SKB Technical Report No 88-19

A BAYESIAN NONPARAMETRIC ESTIMATION OF DISTRIBUTIONS AND QUANTILES

Kurt Pörn

Studsvik AB

November 1988

ABSTRACT

The report describes a Bayesian, nonparametric method for the estimation of a distribution function and its quantiles. The basic theory behind the method has been presented in /Ferguson, 1973/. The method, presupposing random sampling, is nonparametric so the user has to specify a prior distribution on a space of distributions (and not on a parameter space). In the current application, where the method is used to estimate the uncertainty of a parametric calculational model, the Dirichlet prior distribution is to a large extent determined by the first batch of Monte Carlo-realizations. In this case the result of the estimation technique is very similar to the conventional empirical distribution function.

The resulting posterior distribution is also Dirichlet, and thus facilitates the determination of probability (confidence) intervals at any given point in the space of interest. Another advantage is that also the posterior distribution of a specified quantile can be derived and utilized to determine a probability interval for that quantile.

The method was devised for use in the PROPER code package for uncertainty and sensitivity analysis.

CREEP PROPERTIES OF WELDED JOINTS IN OFHC COPPER FOR NUCLEAR WASTE CONTAINMENT

Bo Ivarsson and Jan-Olof Österberg

Swedish Institute for Metals Research

August 1988

ABSTRACT

In Sweden it has been suggested that copper canisters are used for containment of spent nuclear fuel. These canisters will be subjected to temperatures up to 100°C and external pressures up to 15 MPa. Since the material is pure (OFHC) copper, creep properties must be considered when the canisters are dimensioned. The canisters are sealed by electron beam welding which will affect the creep properties.

Literature data for copper – especially welded joints at the temperatures of interest is very scarce. Therefore uniaxial creep tests of parent metal, weld metal, and simulated HAZ structures have been performed at 110°C. These tests revealed considerable differences in creep deformation and rupture strength. The weld metal showed creep rates and rupture times ten times higher and ten times shorter, respectively, than those of the parent metal. The simulated HAZ was equally stronger than the parent metal. These differences were to some extent verified by results from creep tests of cross-weld specimens which, however, showed even shorter rupture times.

Constitutive equations were derived from the uniaxial test results. To check the applicability of these equations to multiaxial conditions, a few internal pressure creep tests of butt-welded tubes were performed. Attempts were made to simulate their creep behaviour by finite differences computer calculations in which the constitutive equations were used. These calculations failed due to too great differences in creep deformation behaviour across the welded joint.

MODELLING URANIUM SOLUBILITIES IN AQUEOUS SOLUTIONS: VALIDATION OF A THERMODYNAMIC DATA BASE FOR THE EQ3/6 GEOCHEMICAL CODES

I Puigdomenech¹⁾ and J Bruno²⁾

¹⁾ Studsvik Nuclear, Environmental Services, Nyköping

²⁾ Royal Institute of Technology, Department of Inorganic Chemistry

October 1988

ABSTRACT

Experimental solubilities of U^{4+} and UO_2^{2+} that are reported in the literature have been collected. Data on oxides, hydroxides and carbonates have been selected for this work. They include results both at 25°C and at higher temperatures.

The literature data have been compared with calculated uranium solubilities obtained with the EQ3/6 geochemical modelling programs and an uranium thermodynamic data base selected for the Swedish nuclear waste management program.

This verification/validation exercise has shown that more experimental data is needed to determine the chemical composition of anionic uranyl hydroxo complexes as well as their equilibrium constants of formation. There is also a need for more solubility data on well characterised alkaline or alkaline-earth uranates.

For the uranyl carbonate system, the calculated results agree reasonably well with the experimental literature values, which span over a wide range of pH, $[CO_3^{2-}]_T$, $CO_2(g)$ -pressure, and T.

The experimental solubility of $UO_2(s)$ agrees also well with the EQ3/6 calculations for pH more than 6. However, in more acidic solutions the experimental solubilities are higher than the calculated values. This is due to the formation of polynuclear hydroxo complexes of uranium(IV), which are not well characterised, and are not included in the thermodynamic data base used in this study.

RADIOLYSIS OF GROUND WATER: INFLUENCE OF CARBONATE AND CHLORIDE ON THE HYDROGEN PEROXIDE PRODUCTION

*T E Eriksen*¹⁾; *P Ndalamba*¹⁾; *H Christensen*²⁾ and *E Bjergbakke*³⁾

¹⁾Royal Institute of Technology, Department of Nuclear Chemistry

²⁾Studsvik Energiteknik AB, Nyköping

³⁾Risö National Laboratory, Roskilde

December 1988

ABSTRACT

Small volumes of aqueous solutions have been subjected to alpha-radiation from a Am-241 source. The irradiated solution was separated from the bulk solution by a glass filter serving as a diffusion barrier.

The H₂O₂ concentration in the bulk solution was monitored by a chemiluminescence technique and the overall production of oxidizing species (H₂O₂/O₂) in irradiated ground water was studied by measuring the Fe²⁺-consumption in ground water initially containing $2 \cdot 10^{-6} \text{ mol} \cdot \text{dm}^{-3} \text{ Fe}^{2+}$.

H₂O₂ yields calculated using the computer program CHEMSIMUL are in fair agreement with experimental yields for "pure" water (pH 8) and aqueous methanol solutions (pH 5). Experimentally $G(\text{H}_2\text{O}_2) = 1.06 \pm 0.1$ was obtained in "pure" water. In solutions containing $2 \cdot 10^{-3} \text{ mol} \cdot \text{dm}^{-3} \text{ HCO}_3^-$ and in ground water $G(\text{H}_2\text{O}_2)$ decreased to 0.69 ± 0.03 . A corresponding decrease in $G(\text{H}_2\text{O}_2)$ was not found in the calculations. The agreement between measured and calculated Fe²⁺ consumption is fair when slow oxidative reactions in the bulk solutions are taken into account.

SOURCE PARAMETERS OF MAJOR EARTHQUAKES NEAR KIRUNA, NORTHERN SWEDEN, DEDUCED FROM SYNTHETIC SEISMOGRAM COMPUTATION

W Y Kim; E Skordas; Y P Zhou and O Kulhanek

Seismological department, Uppsala University

June 1988

ABSTRACT

The earthquakes that have occurred around Kiruna in northern Sweden have been studied in detail in order to determine their source characteristics and to understand the pattern of seismic activity in the region. All earthquakes with magnitude greater than 3.0 (M_L) that occurred during the period between 1967 and 1985 in the region bounded by 66.5 – 69°N and 19 – 25°E are studied.

Relocated epicenters of the events exhibit a cluster of events in a direction NE – SW at the western side of the region close to Kiruna. Though, the focal depths of the events are not very well constrained, the relocation results suggest that the events in this cluster might have occurred at focal depths between 15 and 25 km.

At the eastern side of the region, the epicenters are roughly aligned along an elongated area trending NNW – SSE. The focal depths of the events in this area tend to be shallow and are probably in the upper crust at the depths range from 5 to 16 km.

The earthquakes studied show nearly constant source radii of about 0.4 ca. 0.6 km over the seismic moment range 10^{20} to 10^{21} dyne-cm. Consequently, the events studied are characterized by a steadily increasing stress drop relative to increasing seismic moment.

The source mechanisms obtained for the two largest earthquakes suggest that the mechanisms are dominated by the normal faultings on the near-vertical fault planes trending N-S to NE – SW.

FISSION PRODUCT CONCENTRATION PROFILES (SR, XE, CS AND ND) AT THE INDIVIDUAL GRAIN LEVEL IN POWER-RAMPED LWR FUEL

R S Forsyth; O Mattsson and D Schrire

Studsvik Nuclear

December 1988

ABSTRACT

In addition to dissolution of the UO_2 matrix, the corrosion of spent nuclear fuel in groundwater appears to occur, at least in the short term, by the rapid dissolution of fission product phases formed during reactor irradiation, and by selective attack at zones or segregations in the fuel enriched in fission products.

The Electron Probe Micro-Analysis (EPMA) technique offers the possibility of identifying and analyzing such phases and segregations in spent LWR fuel, although the small amounts expected to be present, and the background radiation, present a significant analytical challenge.

This report describes preliminary work performed to examine the application of the EPMA technique to this problem. The fuel specimen examined had been power-bumped to a linear power rating somewhat higher than those generally experienced by commercial LWR fuel, so that fission product mobility had been enhanced. Steep concentration gradients for xenon and cesium within individual fuel grains, probably due to grain boundary sweeping during grain growth, were detected and measured. With changes in the analytical technique, it is possible that even strontium could be determined.

POSTGLACIAL FAULTING AND PALEOSEISMICITY IN THE LANDSJÄRV AREA, NORTHERN SWEDEN

Robert Lagerbäck

October 1988

ABSTRACT

Post-glacial fault scarps, up to about 20 m in height and forming a 50 km long fault set with a SSW-NNE orientation, occur in the Lansjärv area in northern Sweden. By trenching across the fault scarps it has been possible to date fault movement relative to the Quaternary stratigraphy. It is concluded that the fault scarps generally developed as single-event movements shortly after the deglaciation about 9000 years ago. At one location there are indications that minor fault movements may have occurred earlier during a previous glaciation but this is uncertain. The fault scarps are, at least partially, developed in strongly fractured and chemically weathered zones of presumed pre-Quaternary age. To judge from the appearance of the bedrock fault scarps, and the deformation of the Quaternary deposits, the faults are reverse and have dips between some 40–50 degrees and the vertical.

The faulting was co-seismic and earthquakes in the order of M 6.5–7.0, or higher, are inferred from fault dimensions and the distribution of seismically triggered landslides in a wider region. Distortions in different types of sediment, interpreted as caused by the influence of seismic shock, occur frequently in the area. Examples of these are briefly described.

SKB Technical Report No 88-26

GEOLOGICAL EVIDENCE OF SMECTITE LONGEVITY. THE SARDINIAN AND GOTLAND CASES

Roland Pusch and Ola Karnland

Clay Technology AB

December 1988

ABSTRACT

Parallel to the systematic experimental and theoretical attempts that are being made for identification of the criteria which determine the chemical stability of smectite minerals of clay buffer materials in repositories for high level radioactive repositories, search is going on for geological evidence of natural smectite clay materials that have been exposed to conditions that are similar to those in repositories. Cases in which heating to 90°C or more for long periods has taken place, are of particular interest, the only example that has been considered so far, although not yet in great detail, being the Ordovician Kinnekulle bentonite sequence. The present report describes two other bentonite layers, one of Miocenic age located at central Sardinia (Busachi), and the other of Ordovician age, forming a basal stratum of southern Gotland, (Hamra), Sweden. They both serve as excellent examples of the survival potential of montmorillonite-rich clays.

The more than 10 m thick Sardinian bentonite bed, which is located below 2 m of rhyolite rock and presently exploited for the production of commercial bentonite, was very significantly heated when the magma moved in and covered it. The upper meter was heated to more than 200°C for several days, while at more than 4 m depth, the temperature did not exceed 80°C. The tests show that the smectite content was not reduced to less than 80 % in any part of the layer sequence, while slight cementation was caused by precipitation of heat-released silica in the uppermost layer.

The 0.3 m thick bed on Gotland is presently located at 515 m depth. Various investigations indicate that it has been exposed to an effective pressure of 30 MPa and a temperature of 110°C for several million years due to burial under almost 3 km of Devonian sediments. The content of smectite is around 25 % of the bulk material, and 30–40 % of the clay fraction. Illite appears to have been neofomed in small voids of the smectite matrix and the identified apparent I/S material is suggested to consist of mixed-layer minerals with hydrous mica and Ca or Na locked in instead of K, which would be the

conventional interpretation. The earlier developed alteration model appears to be valid and it is extended in the present report on the basis of the findings.

SKB Technical Report No 88-27

ON THE FORMATION OF A MOVING REDOX-FRONT BY ALPHA-RADIOLYSIS OF COMPACTED WATER SATURATED BENTONITE

Trygve E Eriksen and Pierre Ndalamba

Royal Institute of Technology, Department of Nuclear Chemistry

December 1988

ABSTRACT

The formation of an expanding volume containing the radiolytically formed oxidants H₂O₂ and O₂ has been studied in alpha-irradiated compacted water saturated bentonite ($\rho = 2.12 \text{ g} \cdot \text{cm}^{-3}$). The G-values (0.67 +/- 0.05), (0.64 +/- 0.07) for H₂O₂ and O₂ respectively are in fair agreement with the corresponding G-values obtained in experiments with synthetic ground water. From the leaching of gamma-irradiated bentonite it is concluded that only a fraction of the Fe²⁺ content is easily accessible as scavenger for the radiolytically formed oxidants.

SKB Technical Report No 88-28

RADIONUCLIDE TRANSPORT IN A SINGLE FISSURE. A LABORATORY FLOW SYSTEM FOR TRANSPORT UNDER REDUCING CONDITIONS

Trygve E Eriksen

Royal Institute of Technology, Stockholm Department of Nuclear Chemistry

December 1988

ABSTRACT

A flow system for laboratory studies of radionuclide transport in natural fissures in granitic rock under reducing conditions is described. The system based on the use of synthetic ground water equilibrated with granitic rock in a well sealed system, allow experiments to be carried out at -240mV. In flow experiments with technetium the retardation was found to be dependent on the method used for reducing TcO_4^- .

SKB Technical Report No 88-29

MODELLING OF BUFFER MATERIAL BEHAVIOUR. SOME EXAMPLES OF MATERIAL MODELS AND PERFORMANCE CALCULATIONS

Lennart Børgesson

Clay Technology AB, Lund

December 1988

ABSTRACT

Some material models of smectite rich buffer material suited for nuclear waste isolation are accounted for in the report. The application of these models in finite element calculations of some scenarios and performances are also shown.

The rock shear scenario has been closely studied with comparisons between calculated and measured results. Sensitivity analyses of the effect of changing the density

of the clay and the rate of shear have been performed as well as one calculation using a hollow steel cylinder.

Material models and finite element calculations of canister settlement, thermomechanical effects and swelling are also accounted for.

The report shows the present state of the work to establish material models and calculation tools which can be used at the final design of the repository.

SKB Technical Report No 88-30

RHEOLOGICAL PROPERTIES OF SODIUM SMECTITE CLAY

Lennart Børgesson; Harald Hökmark and Ola Karlund

Clay Technology AB, Lund

December 1988

ABSTRACT

The rheological properties of Na-smectite Mx-80 have been investigated by various laboratory tests. The investigations include determination of the hydraulic conductivity, the undrained stress-strain-strength properties, the creep properties, the compression and swelling properties in drained and undrained conditions and the undrained thermomechanical properties. Measurements have been made at different densities, clay/sand mixtures and pore water compositions. The influence of temperature, rate of strain and testing technique has also been considered.

The investigation has led to a supply of basic data for the material models which will be used at performance calculations. The results have also increased the general understanding of the function of smectitic clay as buffer material.

The microstructural behaviour has been considered at the validation of the different test results and the validity of the effective stress theory has been discussed. Comparisons with the properties of Ca-smectite have also been made.

LONG-TERM DYNAMICS OF A LAKE ECOSYSTEM AND THE IMPLICATIONS FOR RADIATION EXPOSURE

Björn Sundblad; Ulla Bergström; Sverker Evans and Ignasi Puigdomènech

Studsvik Nuclear, Nyköping

September 1988

ABSTRACT

Long-term ageing and physical transformation of ecosystems may occur while a continuous leakage of radionuclides from a repository is going on. This will imply additional uncertainties as regards the consequences for exposure to man.

The turnover of nuclides during the ageing of a lake ecosystem and its successive development into agricultural land is simulated using a multicompartment system. Parameters of a major importance for the distribution and reconcentration of radionuclides supplied into the lake as surface inflow are identified. Seven radionuclides occurring in high-level waste are treated. These are I-129, Cs-135, Ra-226, Pa-231, U-234, Np-237 and Pu-239. The activity distribution is highly dependent on the sorption behaviour of the radionuclides. The major pools for radionuclide distribution are lake outflows 15–97% (Pu-239 – I-129) and deep lake sediment 2–84% (I-129 – Pu-239).

Performed dose calculations for different time periods of the lake evolution showed that the individual doses increase with a factor of hundred for Pu-239 during the life-time of the lake. For comparison doses have also been calculated for two different well scenarios in order to discuss the possibility of generic conversion factors from release to the biosphere and resulting individual doses. However, for all nuclides the obtained doses from exposure from a well situated in the discharge area to the lake were higher than for those obtained from the turnover of lake. For rough estimates the obtained doses can be used as standards when studying the impact on man from the turnover of long-lived radionuclides during the evolution of this type of ecosystem.