

Technical Report

TR-20-10

December 2020



Äspö Hard Rock Laboratory Annual Report 2019

SVENSK KÄRNBRÄNSLEHANTERING AB

SWEDISH NUCLEAR FUEL
AND WASTE MANAGEMENT CO

Box 3091, SE-169 03 Solna
Phone +46 8 459 84 00
skb.se

SVENSK KÄRNBRÄNSLEHANTERING

ISSN 1404-0344

SKB TR-20-10

ID 1907443

December 2020

Äspö Hard Rock Laboratory

Annual Report 2019

Svensk Kärnbränslehantering AB

A pdf version of this document can be downloaded from www.skb.se.

© 2020 Svensk Kärnbränslehantering AB

Abstract

The Äspö Hard Rock Laboratory (HRL) is an important part of SKB's work with the design and construction of a deep geological repository for the final disposal of spent nuclear fuel. Äspö HRL is located in the Simpevarp area in the municipality of Oskarshamn. One of the fundamental reasons behind SKB's decision to construct an underground laboratory was to create opportunities for research, development and demonstration in a realistic and undisturbed rock environment down to repository depth. The underground part of the laboratory consists of a main access tunnel from the Simpevarp peninsula to the southern part of Äspö where the tunnel continues in a spiral down to a depth of 460 m. Äspö HRL has been in operation since 1995 and considerable international interest has been shown in its research, as well as in the development and demonstration tasks. A summary of the work performed at Äspö HRL during 2019 is given below.

Äspö Site Descriptive Model

Geoscientific research is a basic activity at Äspö HRL. The aim of the current studies is to develop geoscientific models of the Äspö HRL and increase the understanding of the rock mass properties as well as knowledge of applicable methods of measurement. Studies are performed in both laboratory and field experiments, as well as by modelling work. The activities aim to provide basic geoscientific data to the experiments and to ensure high quality of experiments and measurements related to geosciences.

The objective for producing *Äspö Site Descriptive Model* is to describe the geological, hydrogeological and groundwater chemical conditions of Äspö HRL including updated geometrical and numerical models for each geoscientific discipline. Data from the underground excavations as well as from the ground surface will be compiled systematically for these three disciplines.

The hydro monitoring programme constitutes a cornerstone for the hydrogeological research and a support to the experiments undertaken in the Äspö HRL. The monitoring system relies on about 1 500 measuring points of various hydrogeological variables.

The hydrochemistry monitoring program is designed as monthly to biannual sampling campaigns depending on the type of aqueous environment. Surface waters are collected from permanent meteorological stations, and temporary stream, lake and sea stations.

Research projects and development of engineered barriers

At Äspö HRL, an important goal is to demonstrate technology for and the function of important parts of the repository system. This implies translation of current scientific knowledge and state-of-the-art technology into engineering practice applicable in an operational repository. It is important that development, testing and demonstration of methods and procedures are conducted under realistic conditions and at an appropriate scale. A number of large-scale field experiments and supporting activities are therefore carried out at Äspö HRL. The experiments focus on different aspects of engineering technology and performance testing.

In addition to studying the engineered barriers, experiments are also related to the rock, its properties and in situ environmental conditions. The aim is to provide information about the long-term function of natural and repository barriers. Experiments are performed to develop and test methods and models for the description of groundwater flow, radionuclide migration, and chemical conditions at repository depth.

A project on *Drilling of deposition holes* has been initiated, developing the techniques for producing deposition holes.

Several projects are ongoing with focus on *System design of buffer and backfill*. During 2019 tests have been performed on bentonite pellets to find optimisations in both material and pellet type, and studies have been made on the early THM processes in the buffer.

Detailed studies are necessary to characterize and document the Forsmark bedrock before the production of the Spent Fuel Repository so that it is constructed in accordance with conditions in the bedrock. The project *Investigation methods for ramp and shaft* will develop documentation for methods that will guide and quality assure the performance of investigations in the Spent Fuel Repository.

Work on concrete barriers. In order to verify that the suggested design solutions for a planned extension of the Final Repository for Short-Lived Radioactive Waste (SFR) can be utilized and to show that the long term safety of the repository is likely to be ensured over the entire post-closure period an R&D programme has been initiated. In order to demonstrate that SKB is able to construct the concrete caissons in accordance with requirements under current prerequisites a development program comprising a number of different development and verification steps has been initiated. This development program includes the steps from material development through casting of a representative section of a concrete caisson in the Äspö Laboratory and monitoring of its properties.

A large number of investigation boreholes have been drilled in both the area for the planned Spent Fuel Repository in Forsmark and for the Final Repository for Short-Lived Radioactive Waste (SFR). A new technology development project on *Sealing of boreholes* was therefore initiated in 2015 with the goal to optimize the sealing of SKBs investigation boreholes in Forsmark.

Bentonite material studies. SKB has developed methods and techniques for acquisition and quality control of bentonite for a long time. The long term safety requirements on the bentonite are quantified into a number of parameters; swelling pressure, hydraulic conductivity, shear strength, thermal conductivity and limitations in sulphide, total sulphur and carbon (harmful substances).

The Prototype Repository is a demonstration of the integrated function of the repository and provides a full-scale reference for tests of predictive models concerning individual components as well as the complete repository system. The layout involves altogether six deposition holes, four in an inner section and two in an outer. The relative humidity, pore pressure, total pressure and temperature in different parts of the test area are monitored. The outer test section was retrieved during 2011 after approximately eight years of water uptake of the buffer and backfill. The monitoring of the inner section will be continued at least until 2020.

In the project *Concrete and Clay* the aim of the project is to increase our understanding of the processes related to degradation of low and intermediate level waste in a concrete matrix, the degradation of the concrete itself through reactions with the groundwater and the interactions between the concrete/groundwater and adjacent materials such as bentonite and the surrounding host rock. During the time period 2010–2014 a total of 9 packages comprising concrete cylinders or bentonite blocks each containing different types of waste form materials were deposited at different locations in the Äspö HRL. The four concrete specimens were prepared and deposited during 2010 and 2011. During 2014 the bentonite specimens comprising 150 bentonite blocks in 5 different packages were installed in TAS06. During 2017 and 2018 one experiment parcel was retrieved and analysed and in 2019 the results were reported.

The *Alternative Buffer Materials (ABM)* project was started in 2006 with the purpose to evaluate different bentonites as possible buffer candidates. The ABM project consists of a combination of field experiments at the Äspö HRL and laboratory studies of the bentonites performed at a variety of laboratories, including both SKB and external partners.

SKB and Posiva are co-operating on a programme for the *KBS-3 Method with Horizontal Emplacement (KBS-3H)*. A continuation phase of the concept development is ongoing and the aim of this phase is to reach a level of understanding so that comparison of KBS-3H and KBS-3V (reference concept for both SKB and Posiva), and preparation of a PSAR, becomes possible. The most recent project phase was 2011-2017. It covers all areas of the KBS-3 method but the focus is on the KBS-3H specific issues.

The aim of the *Large Scale Gas Injection Test (Lasgit)* is to perform gas injection tests in a full-scale KBS-3 deposition hole. The installation phase, including the deposition of canister and buffer, was

finalised in 2005. Water is artificially supplied and the evolution of the saturation of the buffer is continuously monitored. The preliminary hydraulic and gas injection tests were completed in 2008. During 2018 the test programme of Lasgit continued a phase of prolonged “hibernation” with monitoring of the natural and artificial hydration of the bentonite buffer.

The objective of the project *In situ Corrosion Testing of Miniature Canisters* is to obtain a better understanding of the corrosion processes inside a failed canister. In Äspö HRL in situ experiments are performed with defect miniature canisters (defect copper shell with cast iron insert). The canisters are exposed to both natural groundwater and groundwater which has been conditioned by bentonite. Five canisters were installed in boreholes in the end of 2006/beginning of 2007. The first canister was retrieved and analysed in 2011. Two additional canisters were retrieved and analysed during 2015.

The Long Term Test of Buffer Material (LOT) project aims at studying possible alteration of the bentonite as a result of the hydro-thermal evolution, both with respect to mineralogy and to sealing properties. The LOT test series includes seven test parcels, which all contain a heater, central tube, clay buffer, instruments and parameter controlling equipment. Two test parcels have been dismantled during 2019, and analyses are ongoing.

Mechanical and system engineering

At Äspö HRL and the Canister Laboratory in Oskarshamn, methods and technologies for the final disposal of spent nuclear fuel are being developed. Established as well as new technology will be used in the Spent Fuel Repository in Forsmark. The approximately 200 technical systems, machines and vehicles that are needed in the final repository have been identified and listed in a database called FUMIS. Extensive work has been put into assessing the degree of development and prototyping needed, costs, schedule, deadlines etc. During 2019, a project aimed at designing the equipment needed for backfill installation has been active at Äspö.

Äspö facility

The Äspö facility comprises both the Äspö Hard Rock Laboratory and the Research Village with laboratories. The main goal for the operation of the Äspö facility is to provide a facility which is safe for everybody working in, or visiting it, and for the environment. This includes preventative and remedial maintenance in order to ensure that all systems such as drainage, electrical power, ventilation, alarm and communications are available in the underground laboratory at all times.

In *the Multipurpose test facility* different methods and techniques for installation of pellets and blocks in deposition tunnels are tested, and work on buffer and backfill is performed. Several projects have performed activities in the facility during 2019.

As a part of the needed infrastructure, a *Material science laboratory* has been constructed at Äspö, with focus on material chemistry of bentonite issues and competence development. The key focus areas are long term safety related research and development of methods for quality control of the bentonite buffer and backfill materials. The laboratory is used in a number of projects and activities including technological development in the material science projects, and for various research studies such as the analysis of long term field experiments such as LOT and Alternative Buffer Material.

The Water Chemistry Laboratory at Äspö HRL perform the sampling and analyses on water samples collected in streams, lakes and boreholes in the surrounding area and the tunnel. For the moment the Chemistry Laboratory can perform 14 different analyses for water samples.

The main goal for *the operation of the facility* of the rock laboratory is to provide a high service function and a customized availability for projects and external customers. The target was met well in 2019 despite great rock maintenance work and experiments.

The main goal for the unit *Communication Oskarshamn* is to create public acceptance for SKB, which is done in co-operation with other departments at SKB. During 2019, 1 902 people visited the Äspö HRL. The unit also arranged a number of events and lectures.

Future use of Äspö HRL

SKB is conducting work with the intent to seek alternative possibilities for adaptation of the Äspö Hard Rock Laboratory into a high level national research- and innovation infrastructure. The work is being spurred both by an active external interest in the future use of Äspö HRL and by a strategic vested interest. During 2019 work has been carried out within several development activities.

SKB International

SKB International offers technology, methodology and expert resources to international clients. SKB International has access to all expertise, experience and technologies that SKB has acquired and developed in its programme, and provides services to organisations and companies in spent nuclear fuel and nuclear waste management and disposal and hence provides the opportunity to save time and cost and minimise risk. During November 2019 SKB International and SKB organised a scientific training course covering important issues governing a national nuclear waste disposal programme.

Sammanfattning

Äspölaboratoriet i Simpevarp i Oskarshamns kommun är en viktig del i SKB:s arbete med utformning, byggande (och drift) av ett Kärnbränsleförvar. Ett av de grundläggande skälen till SKB:s beslut att anlägga ett underjordslaboratorium var att skapa förutsättningar för forskning, utveckling och demonstration i en realistisk och ostörd bergmiljö på försvarsdjup. Underjordslaboratoriet utgörs av en tunnel från Simpevarpshalvön till södra delen av Äspö där tunneln fortsätter i en spiral ner till 460 meters djup. Äspölaboratoriet har varit i drift sedan 1995 och verksamheten har väckt stort internationellt intresse. Här följer en sammanfattning av det arbete som bedrivits vid Äspölaboratoriet under 2018.

Äspö Site Descriptive Model

Forskning inom geovetenskap är en grundläggande del av arbetet vid Äspölaboratoriet. Det huvudsakliga målet med de pågående studierna är att utveckla geovetenskapliga modeller samt att öka förståelsen för bergmassans egenskaper och kunskapen om användbara mätmeter. Studier genomförs i både laboratorier och fältexperiment, samt modelleringsarbete. Aktiviteterna levererar geovetenskaplig data till experiment och säkerställer hög kvalitet på experiment och mätningar inom geovetenskap.

Syftet med att producera *Äspö Site Descriptive Model* är att beskriva Äspö HRL:s geologiska, hydrogeologiska och grundvattenkemiska förhållanden, inklusive uppdaterade geometrisk och numeriska modeller för de olika geovetenskapliga disciplinerna.

Programmet för hydromonitoring utgör en grundsten i Äspö HRL:s hydrogeologiska undersökningar, och stödjer olika experiment som genomförs. Monitoringsystemet baseras på cirka 1 500 mätpunkter för olika hydrogeologiska variabler.

Programmet för hydrokemisk monitorering utför provtagningar i intervall från månadsvis till två gånger per år, beroende på typ av vattenmiljö. Ytvatten samlas in från permanenta mätstationer, samt temporära provpunkter i strömmar, sjöar och hav.

Forskningsprojekt och barriärutveckling

Verksamheten vid Äspölaboratoriet har som mål att demonstrera KBS-3-systemets funktion. Detta innebär att vetenskapliga och teknologiska kunskaper används praktiskt i arbetet med att utveckla, testa och demonstrera de metoder och tillvägagångssätt som kan komma att användas vid uppförandet av ett Kärnbränsleförvar. Det är viktigt att möjlighet ges att testa och demonstrera hur KBS-3-systemet kommer att utvecklas under realistiska förhållanden. Ett flertal projekt i full skala, liksom stödjande aktiviteter, pågår vid Äspölaboratoriet. Experimenten fokuserar på olika aspekter av ingenjörsteknik och funktionstester.

Experimenten kopplar även till berget, dess egenskaper och in situ förhållanden. Målet med de pågående experimenten är att ge information om hur de naturliga och tekniska barriärerna fungerar i ett långtidsperspektiv. Experiment genomförs för att utveckla och testa metoder och modeller för grundvattenflöde, radionuklid-transport och kemiska förhållanden på försvarsdjup.

Ett projekt har initierats inom *Borring av deponeringshål*, vilket ska utveckla tekniker för produktionen av deponeringshål.

Flera projekt pågår med fokus på *Systemkonstruktion av buffert och återfyllnad*. Under 2019 har tester genomförts på bentonitpellets för att identifiera optimeringar i både materialval och pellettyp, och tidiga THM-processer i bufferten har studerats.

Detaljerade undersökningar krävs för att karakterisera och dokumentera berggrunden i Forsmark inför den planerade konstruktionen av Kärnbränsleförvaret så att det konstrueras i enlighet med

förutsättningarna i berggrunden. Projektet *Undersökningsmetoder för ramp och schakt* tar fram dokumentation av metoder som kommer guida och kvalitetssäkra genomförandet av undersökningar i Kärnbränsleförvaret.

Betongbarriärer. För att verifiera designen inför den planerade utbyggnaden av Slutförvaret för kortlivat radioaktivt avfall, SFR, har ett forskningsprogram initierats. Detta inkluderar steg från materialutveckling till gjutning av en testsektion av en betongkassun i Äspölaboratoriet.

Ett stort antal undersökningsborrhål har borrats både i områdena för det planerade Kärnbränsleförvaret och Slutförvaret för kortlivat radioaktivt avfall (SFR). Ett nytt teknikutvecklingsprojekt kring *Förslutning av borrhål* initierades 2015 med målet att optimera förslutningen av SKB:s undersökningsborrhål i Forsmark.

Materialstudier av bentonit. SKB har utvecklat metoder och tekniker för inköp och kvalitetskontroll av bentonit under en lång tid. Kraven på långsiktig säkerhet för bentoniten har kvantifierats till ett antal uppmätta parametrar.

I Prototypförvaret pågår en demonstration av den integrerade funktionen hos förvarets barriärer. Prototypförvaret utgör dessutom en fullskalig referens för prediktiv modellering av Kärnbränsleförvaret och barriärernas utveckling. Prototypförvaret omfattar totalt sex deponeringshåll, fyra i en inre tunnelsektion och två i en yttre. Mätningar av relativ fuktighet, portryck, totalt tryck och temperatur i olika delar av testområdet genomförs kontinuerligt. Den yttre sektionen bröts och kapslarna återtog under 2011. Moniteringen av den inre sektionen kommer fortsätta till minst år 2020.

I "*Betong- och lerprojektet*" är syftet att öka förståelsen för processer i samband med nedbrytning av låg- och medelaktivt avfall i en betongmatrix, nedbrytning av betongen självt genom reaktioner med grundvattnet och växelverkan mellan betong, mark och angränsande material som bentonit och den omgivande berggrunden. Under 2017-2018 återtog ett experimentpaket och resultaten av analyser rapporterades under 2019.

Försöket *Alternativa buffertmaterial (ABM)* startades 2006 med syftet att utvärdera olika bentonitmaterial som möjliga kandidater till bufferten. ABM-projektet består av en kombination av fältexperiment och laboratorieförsök på ett flertal laboratorier både hos SKB och externa parter.

Ett forskningsprogram för ett *KBS-3-förvar med horisontell deponering (KBS-3H)* genomförs som ett samarbetsprojekt mellan SKB och Posiva. Nu pågår en fortsättningsfas av projektet med målsättningen att utveckla KBS-3H till en sådan nivå att en jämförelse mellan 3V/3H och förberedelser inför en PSAR är möjlig. Den senaste projektfasen pågick under 2011-2017. Fasen täcker samtliga delar av KBS-3 metoden men fokuserar på KBS-3H specifika frågor.

Syftet med ett *Gasinjekteringsförsök i stor skala (Lasgit)* är att studera gastransport i ett fullstort deponeringshåll (KBS-3). Installationsfasen med deponering av kapsel och buffert avslutades under 2005. Vatten tillförs bufferten på artificiell väg och utvecklingen av vattenmättnadsgraden i bufferten mäts kontinuerligt. Under 2008 avslutades de preliminära hydrauliska testerna och gasinjekterings-testerna. Under 2018 fortsatte en förlängd fas av vila, med monitering av den naturliga och artificiella bevätningen av bentonitbufferten.

Målet med projektet *In situ testning av korrosion av miniatyrkapslar* är att få en bättre förståelse av korrosionsprocesserna inuti en trasig kapsel. Vid Äspölaboratoriet genomförs in situ experiment med defekta miniatyrkapslar (genomborrad kopparhölje med gjutjärnsinsats) som utsätts för både naturligt grundvatten och grundvatten som filterats av bentonit. Fem kapslar installerades i borrhål runt årsskiftet 2006/2007 och sedan dess har flera rapporter publicerats som beskriver själva installationen och kemiska, elektrokemiska och mikrobiologiska mätresultat som erhållits. Under 2011 återtog en av experimentkapslarna, kapsel tre. Ytterligare två kapslar återtog 2015.

Projektet *Långtidstest av buffertmaterial (LOT)* syftar till att studera möjliga förändringar i bentoniten som ett resultat av hydro-termisk evolution, både sett till mineralogi och tätningsegenskaper. LOT-försöket inkluderar sju uppvärmda testpaket. Två testpaket har återtagits under 2019, och analyser pågår.

Maskin- och systemteknik

Vid Äspölaboratoriet och Kapsellaboratoriet i Oskarshamn utvecklas teknik och metoder för Kärnbränsleförvaret. Befintlig liksom nyutvecklad teknik kommer att användas. De omkring 200 tekniska system, maskiner och fordon som behövs har identifierats och har dokumenterats i en databas, FUMIS. Ett omfattande arbete har gjorts för att bedöma grad av nyutveckling, behov av prototypframtagning, kostnad, tidplaner etc. Under 2019 har ett projekt som tar fram design för utrustning för återfyllnadsinstallation haft aktiviteter på Äspölaboratoriet.

Äspölaboratoriet

I *Äspöanläggningen* ingår både det underjordiska berglaboratoriet och Äspö forskarby. En viktig del av verksamheten vid Äspöanläggningen är administration, drift och underhåll av instrument samt utveckling av undersökningsmetoder. Huvudmålet för driften av Äspöanläggningen är att garantera säkerheten för alla som arbetar i eller besöker anläggningen samt att driva anläggningen på ett miljömässigt korrekt sätt.

I *Testhallen* provas olika metoder och tekniker för installation av pelletar och block i deponeringstunnlar och studier av erosion av buffert och återfyllningsmaterial utförs. Flera projekt har haft aktivitet i Testhallen under 2019.

Ett *Laboratorium för Materialstudier* finns på Äspö, med fokus på materialkemi för bentonitfrågor och kompetensutveckling. De största fokusområdena är metodutveckling för kvalitetskontroll av bentonit som ska användas som buffert- och återfyllningsmaterial. Laboratoriet nyttjas för ett flertal projekt och aktiviteter som teknikutveckling i Materialprojektet och för studier så som analyser av långtidsförsök som LOT och ABM.

Vattenkemilaboratoriet på Äspö HRL genomför provtagning och analys av vattenprover insamlade från vattendrag, sjöar och borrhål i omgivande områden och Äspötunneln. För nuvarande kan Kemilaboratoriet utföra 14 olika analyser på vattenprover.

Huvudmålet med *driften* av anläggningen är att hålla en hög servicenivå och anpassad tillgänglighet för projekt och externa kunder. Målet uppnåddes väl under 2019 trots mycket bergarbete och ett flertal genomförda försök.

Det huvudsakliga målet för enheten *Kommunikation Oskarshamn* är att skapa en allmän acceptans för SKB, vilket görs i samarbete med andra avdelningar inom SKB. Under 2019 besöktes Äspölaboratoriet av 1 902 personer. Enheten arrangerade ett flertal evenemang och föreläsningar under året.

Framtida bruk av Äspö HRL

SKB bedriver ett utredningsarbete med avsikt att söka alternativa möjligheter till omställning av Äspölaboratoriet till en nationell forsknings- och innovationsinfrastruktur i världsklass. Utredningsarbetet sporras dels av ett aktivt omvärldsintresse för Äspölaboratoriets framtida användning dels av ett strategiskt egenintresse. Under 2019 har arbete utförts inom flera utvecklingsaktiviteter.

SKB International

SKB International erbjuder teknologi, metodologi och expertresurser till internationella klienter. SKB International har tillgång till all den expertis, erfarenhet och teknik som SKB har införskaffat och utvecklat i sitt forskningsprogram, och tillhandahåller service till företag och organisationer inom slutförvar av använt kärnbränsle. De kan därmed bidra både till besparingar i tid och pengar, samt en möjlighet att minimera risker. Under november 2019 arrangerade SKB International och SKB en vetenskaplig kurs som omfattade viktiga frågor för ett nationellt slutförvarsprogram.

Contents

1	General	13
1.1	Background	13
1.2	Goals	15
1.3	Organization	16
1.4	Allocation of experiment sites	16
1.5	Reporting	17
1.6	Structure of this report	17
2	Äspö site descriptive modelling (SDM)	19
2.1	General	19
2.2	Geology	19
2.3	Hydrogeology	19
	2.3.1 Äspö Site descriptive modelling	19
	2.3.2 Hydro Monitoring Programme	20
2.4	Geochemistry	22
	2.4.1 Hydrochemistry monitoring program	23
3	Research projects and development of engineered barriers	25
3.1	General	25
3.2	Drilling of deposition holes	25
3.3	System design of buffer and backfill	27
	3.3.1 Buffer pellet design	27
	3.3.2 Early THM processes in the buffer	29
3.4	Investigation methods for ramp and shaft	32
3.5	Work on concrete barriers	34
3.6	Sealing of boreholes	38
3.7	Bentonite material studies	42
3.8	Projects in a monitoring phase	50
	3.8.1 Prototype Repository	50
	3.8.2 Concrete and Clay	52
	3.8.3 Alternative Buffer Materials	57
	3.8.4 KBS-3 Method with Horizontal Emplacement	59
	3.8.5 Large Scale Gas Injection Test	61
	3.8.6 In Situ Corrosion Testing of Miniature Canisters	63
	3.8.7 Long term tests of buffer material	65
4	Mechanical- and system engineering	77
4.1	General	77
4.2	Backfill installation equipment	77
5	Äspö facility	81
5.1	General	81
5.2	Multipurpose test facility	81
5.3	Material Science Laboratory	81
5.4	Water Chemistry Laboratory	84
5.5	Facility Operation	85
5.6	Communication Oskarshamn	85
5.7	Future use of Äspö HRL	86
	5.7.1 Planning prerequisites	86
	5.7.2 Continuation or cease of operations in the Äspö underground laboratory	87
	5.7.3 Status of the continuation of operations alternative	87
6	SKB International	91
6.1	Background history	91
6.2	Support and services related to Äspö	91
	6.2.1 SKB International can customise following services:	91
6.3	Activities and support during 2019	92
6.4	Contact information	93
	References	95

1 General

The Äspö Hard Rock Laboratory (HRL) is a unique research facility that extends down to a depth of 460 metres in the Swedish bedrock. For more than 30 years, this site has been central for the development of safe methods for final disposal of spent nuclear fuel.

At Äspö HRL, the Swedish Nuclear Fuel and Waste management Co (SKB) has built up a large part of the knowledge that is now being used in the detailed design and preparations for the construction of a Spent Fuel Repository in Forsmark, as well as experience that will be used during the construction phase and future operation of the repository.

It is fair to say that Äspö HRL has contributed to world-wide knowledge about final disposal of radioactive waste in crystalline rock and today the facility serves as a model to other countries planning for design and construction of deep geological repositories for radioactive waste.

The Äspö HRL is not only an underground laboratory. On the surface lies Äspö Research Village with laboratory areas for accredited hydrochemical analyses, research activities and advanced bentonite clay examinations. Furthermore, there is a large testing hall, including an overhead crane, which is used as a multipurpose facility for various technical developments.

Well worth noting, SKB is today offering Äspö as an open resource for both national and international customers within wide-ranging sciences.

This report summarises the main accomplishments and initiatives carried out during 2019.

1.1 Background

Äspö HRL is located in the south east coast of Sweden, on the island Äspö, 25 kilometers north of Oskarshamn.

It was in SKB's Research, Development and Demonstration (RD&D) Programme 1986 that SKB first presented the idea of a new underground research facility. One of the fundamental reasons behind SKB's decision to construct an underground laboratory was to create an opportunity for research, development and demonstration in a realistic and undisturbed rock environment at representative repository depth.

The underground part of the laboratory consists of a main access tunnel from the Simpevarp peninsula to the southern part of the Äspö island where the tunnel continues in a spiral down to a depth of 460 m, see Figure 1-1. The total length of the tunnel ramp is 3 600 m where the main part of the tunnel has been excavated by conventional drill and blast technique and the last 400 m have been excavated by a tunnel boring machine (TBM) with a diameter of 5 m. The underground tunnel system is connected to the ground surface through a hoist shaft and two ventilation shafts. Thanks to the 20 passenger elevator, easy access to the underground laboratory is offered from the office building at the Äspö Research Village.

The work with Äspö HRL has been divided into three phases: Pre-Investigation phase, Construction phase and Operational phase.

During the Pre-Investigation phase, 1986–1990, extensive field studies were made to provide a basis for the decision to locate the laboratory to a suitable site. The natural conditions of the bedrock were described and predictions made of geological, hydrogeological, geotechnical and rock-mechanical conditions to be observed during excavation of the laboratory. This phase also included planning for the construction and operational phases.

During the Construction phase, 1990–1995, comprehensive investigations and experiments were performed in parallel with construction of the laboratory. The excavation of the main access tunnel and the construction of the Äspö Research Village were completed. The construction gave important technological experience and invaluable knowledge about the design and construction of underground

facilities. For example both blasting and full-face drilling were used to excavate the tunnels which made it possible to study how the rock around a tunnel is affected by the different excavation methods and what impact there could be on the flow patterns of groundwater.

The Operational phase began in 1995. A preliminary outline of the programme for this phase was given in SKB's RD&D Programme 1992. Since then the programme has been revised every third year and the detailed basis for the period 2020–2025 is described in SKB's RD&D-Programme 2019 (SKB 2019a).

After the start of operation in 1995, experiments began gradually to investigate how the engineered barriers (canister, buffer, backfill and closure) of the Spent Fuel Repository could be designed and managed in order to provide optimal functionality and safety. A great number of experiments have been conducted to probe the features of the rock and not least what significance such features could have for the post closure safety of a geological repository for spent nuclear fuel. This can, for instance, concern how the rock retards the movement of radioactive substances or how microbes affect conditions at repository depth. The results and knowledge from these efforts have served as a basis for defining the rock's safety-related function in relation to the engineered barriers.

Äspö HRL has also been important for development and demonstration of methods for operating the future Spent Fuel Repository. Tests have been carried out on almost all of the KBS-3 method's subsystems in a realistic setting, a number of them in full scale. The results from several of these experiments comprised important material to support SKB's application for the KBS-3 system that was submitted to the Swedish authorities in 2011.

SKB's technical development is now focused on improved rock excavation technologies and design, manufacturing and installation of the engineered barriers, including several steps of quality controls.

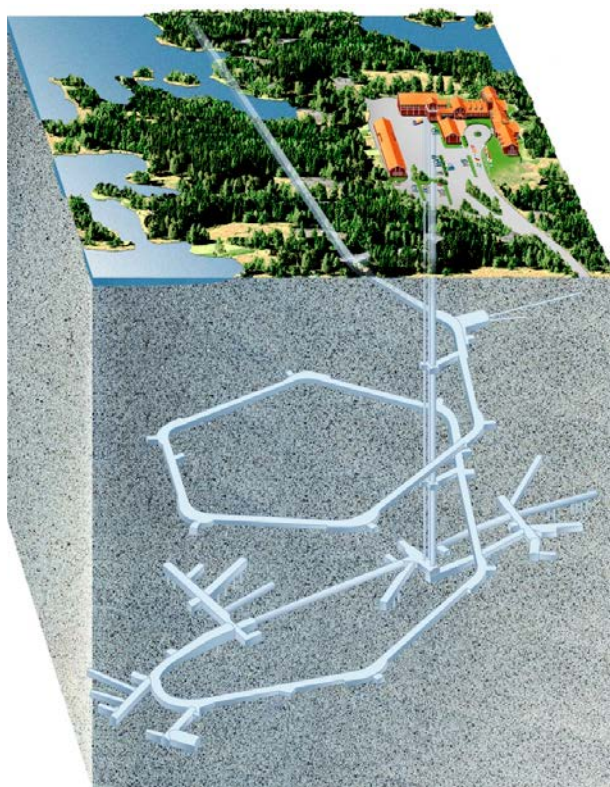

Figure 1-1. Overview of the Äspö HRL facilities.

Tests are also performed to investigate, in detail, the initial performances of the engineered barriers subsequent to installation. All practical means of constructing a repository and emplacing the canisters with spent fuel are dealt with at the laboratory. This work also includes the development and testing of methods for use in the characterisation of a suitable repository site as well as the operative investigation methods to be used during construction of the underground openings.

Furthermore, Äspö HRL will be used by SKB to prepare the extension of the Final Repository for Short-Lived Radioactive Waste, the SFR at Forsmark. Specifically, the construction and control methods of casting concrete barrier caissons will be demonstrated in large scale under realistic conditions.

In addition, research projects are carried out for future analyses of post closure safety for SFR and SFL (the Swedish repository for Long-Lived Radioactive Waste) focused on studies of interactions between different types of barrier materials relevant to these repositories and for different types of materials that are representative of low- and intermediate-level waste.

1.2 Goals

To meet the overall time schedule for SKB's RD&D work, the following stage goals were initially defined for the work at the Äspö HRL:

1. *Verify pre-investigation methods* – demonstrate that investigations on the ground surface and in boreholes provide sufficient data on essential safety-related properties of the rock at repository level.
2. *Finalise detailed investigation methodology* – refine and verify the methods and the technology needed for characterisation of the rock in the detailed site investigations.
3. *Test models for description of the barrier functions at natural conditions* – further develop and, at repository depth, test methods and models for description of groundwater flow, radionuclide migration and chemical conditions during operation of a repository as well as after closure.
4. *Demonstrate technology for and function of important parts of the repository system* – in full scale tests, investigate and demonstrate the different components of importance for the long-term safety of a Spent Fuel Repository and show that high quality can be achieved in design, construction and operation of repository components.

Goal number 1 was reached at an early stage and was preparatory to the site investigations which have been implemented successfully in Oskarshamn and Forsmark.

Goal number 2 is not yet fully reached. The lessons learned from the detailed investigations during the construction phase, and the expansion of new galleries, are now used as a basis when planning for the coming detailed investigations in the Spent Fuel Repository in Forsmark. Technology development is still ongoing for certain issues.

Goal number 3 has been reached completely.

SKB's tasks related to goal number 4 will continue at Äspö HRL at least until 2024. SKB has recently made a clear statement to open the Äspö facilities for a broader range of activities in the future and thus invite new stakeholders and projects. Accordingly, a new goal has been set for Äspö, namely that the underground laboratory can continue in a renewed constellation after SKB has completed most of its operations in 2024.

1.3 Organization

The Äspö HRL is included in the department Research and Development (R) at SKB.

The Research and Development department comprises four units; Repository Technology (RD), Encapsulation Technology (RI), Site Modelling and Monitoring (RP) together with Research and Post-closure Safety (RS).

The unit *Repository Technology* is the residence of Äspö HRL and includes employees in Äspö, Stockholm and Forsmark. The main responsibilities of the unit are to:

- Develop, demonstrate and streamline repository technology for nuclear waste, including deposition tunnels, production and installation methods for the engineered barriers, transport and logistics as well as all necessary quality control methods.
- Develop, manage and operate Äspö HRL as an attractive resource for experiments, demonstration tests and visitor activities.
- Actively work for a broadened use of Äspö HRL, with the aim that additional research and development activities can use the underground laboratory in the future.

The *Repository Technology (RD)* unit is organised in the following groups;

- *Technology Development (RDT)*, providing competence for the technology development required for production and installation of concrete- and bentonite barriers; plugs, backfill, buffer and closure including the equipment, machines and vehicles needed in the repository facility. Project managing competence is also included in the group.
- *Operations and technical support (RDD)*, responsible for the operation and maintenance of the Äspö HRL offices, workshops and underground facilities and for development, operation and maintenance of supervision systems. The group is also responsible for the preparations and practical coordination of projects undertaken at the Äspö HRL, providing services (design, site selection, installations, measurements, field equipment, monitoring systems etc) and workers safety to the experiments.
- *Chemistry (RDK)*, responsible for water sampling and accredited chemical water analysis and bentonite material analysis. The group coordinates all activities inside the research laboratory.

Each major research and development task, ordered by SKB and carried out in Äspö HRL, is organised as a project or assignment led by a Project Manager reporting to the client organisation. Each Project Manager is assisted by an on-site coordinator with responsibility for coordination and execution of project tasks at the Äspö HRL. The professional staff at the site office provides technical and administrative service to the projects.

Much of the research in Äspö HRL is undertaken in collaboration with other experts, universities and organizations. There is extensive collaboration when it comes to sharing technological expertise and experiences with SKB's peer organizations in other countries. SKB International is responsible for the Äspö International Joint Committee (IJC), which during last year consisted of five external member organisations; BMWi, RWM, NUMO, CRIEPI and JAEA. The committee is responsible for the coordination of the experimental work arising from the international participation.

1.4 Allocation of experiment sites

The rock volume and the available underground openings are allocated for the different experiments so that optimal conditions are obtained for each purpose, see Figure 1-2.

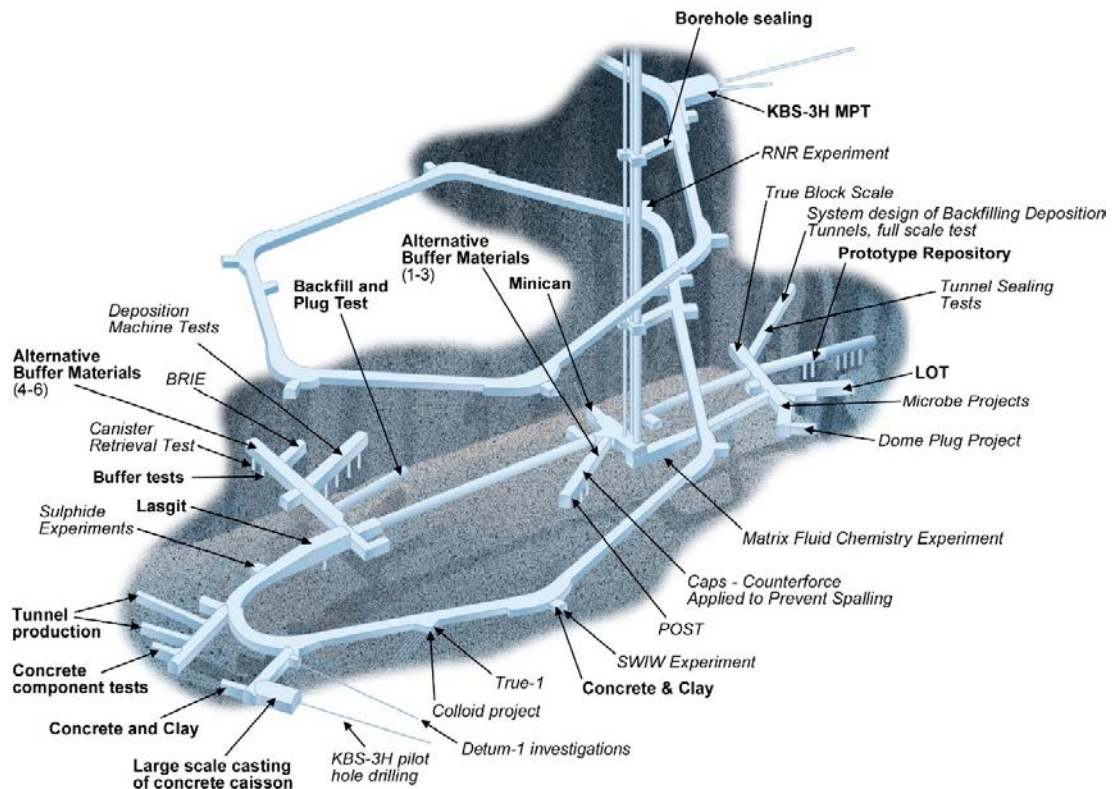

Figure 1-2. Allocation of experiment sites from –220 m to –460 m level. Ongoing experiments in bold text.

1.5 Reporting

The plans for research and technology development during 2020-2025 are described in SKB's RD&D-Programme 2019 (SKB 2019a).

Detailed account of achievements to date for the Äspö HRL can be found in the Äspö HRL Annual Reports that are published in SKB's Technical Report series. This report describes the general achievements during 2019.

Detailed project information is continuously published in SKB's report series' (TR-, R- and P-reports). SKB also endorses publications of results in international scientific journals. Data collected from experiments and measurements at Äspö HRL are mainly stored in SKB's site characterisation database, SICADA.

1.6 Structure of this report

The achievements obtained at Äspö HRL during 2019 are in this report described in five chapters:

- Äspö site descriptive modelling (SDM) – geoscience experiments, analyses and modelling to increase the knowledge of the surrounding rock.
- Research projects and development of engineered barriers – experiments, analyses and modelling to increase the knowledge of the repository barriers under natural conditions, demonstration of technology for and function of important engineered parts of the repository barrier system.
- Mechanical and system engineering – developing of technologies for the final disposal of spent nuclear fuel.
- Äspö facility – laboratories, operation and maintenance, communication activities and future plans.
- SKB International – services and support related to Äspö HRL.

2 Äspö site descriptive modelling (SDM)

2.1 General

The objective for producing Äspö site descriptive model is to describe the geological, hydrogeological and groundwater chemical conditions of Äspö HRL including updated geometrical and numerical models for each geoscientific discipline. Data from the underground excavations as well as from the ground surface will be compiled systematically for these three disciplines.

The work will result:

- in a modern and updated site descriptive model and comprehensive quality checked data, updated with all available data until the end of 2016 and summarized in public report,
- in further understanding of the geological, hydrogeological and groundwater chemical conditions and processes in the rock mass at Äspö HRL,
- in testing of the developed methodology for iterative and integrated modelling,
- in further development of the modeling methodologies.

Added value of the work is to:

- develop the geoscientific model by using the same means, methods and resolution as is intended for the facility part scale models intended to be developed during construction and operation of the planned Spent Fuel Repository in Forsmark,
- train the staff at Äspö and Forsmark to learn and further understand modelling tools, software packages and methodology concerning conceptual and deterministic modelling methodology.

2.2 Geology

Interim versions of the geological models have been produce and the modelling activities are currently limited to the preparations for integrations with the other geo-sisciplines.

2.3 Hydrogeology

The hydrogeologic activities at Äspö HRL during this year comprised maintenance and updating of the Äspö site descriptive model, operation and maintenance of the hydrogeological monitoring system as well as hydrogeological expert support to experiments and projects at the laboratory. The hydrogeological expertise at Äspö was also utilised in support of other projects within SKB. The modelling and monitoring work is described below, experiments and projects are reported under their own heading elsewhere in this annual report.

2.3.1 Äspö Site descriptive modelling

Background

An understanding of the hydrogeological framework, i.e. geometries, processes and parameters, is often a requirement from the different experiments undertaken in the Äspö HRL tunnel. This understanding has developed over time with a first descriptive model produced 1997 and a second one in 2002.

Through the different experiments and projects undertaken in the tunnel, additional data is collected and understanding is gained for the local experimental volume. As such this local knowledge constitutes a building block for integration in the larger scale site descriptive volume. With new experiments new local models are providing input to the gradual updating and refining of the site descriptive model.

The main features are the inclusion of data collected from various experiments and the adoption of the modelling procedures developed during the Site Investigations at Oskarshamn and Östhammar. The intention is to develop the site descriptive model (SDM) into a dynamic working tool suitable with short turn over times for predictions in support of the experiments in the laboratory as well as to test hydrogeological hypotheses in order to improve the conceptual understanding.

Objectives

The major aims of the site descriptive model and modelling are to:

- Maintain and develop the understanding of the hydrogeological properties of the Äspö HRL
- rock mass.
- Support of experiments and measurements in the hydrogeological field
- Maintain and develop the methodology for site descriptive modelling

Experimental concept

The concept is to recurrently compile and evaluate new hydrogeological along with the previous data as a base for revising and updating the modelling/model and the geoscientific understanding of the site. And develop the internal expertise in site descriptive modelling.

Results

The hydrogeological component of the Äspö SDM progressed with the data compilation and evaluation as well as with the hydrogeological parameter assignment to the rock and deformations zone units of the single hole interpretations. A methodology was established and executed for K-value assignment to single hole rock units and deformation zones. Work is on-going.

2.3.2 Hydro Monitoring Programme

Background

The hydro monitoring programme constitutes a cornerstone for the hydrogeological research and a support to the experiments undertaken in the Äspö HRL. Monitoring was also required by the water rights court, when granting the permission to execute the construction works for the tunnel. A staged approach of monitoring has been adopted according to Figure 2-2. Monitoring initiated as part of the pre-investigation for the site selection process. Upon completed characterisation boreholes were retained for long term monitoring in support of establishing a baseline. The monitoring system is also utilised for characterisation during construction and to develop site descriptive models.

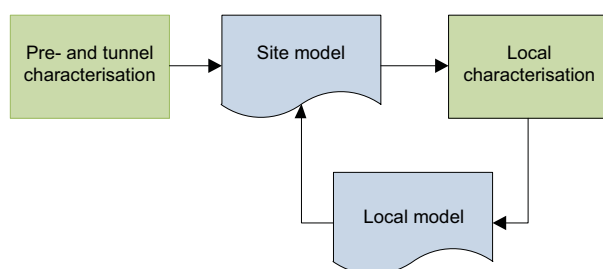

Figure 2-1. Evolution of local- and site descriptive model.

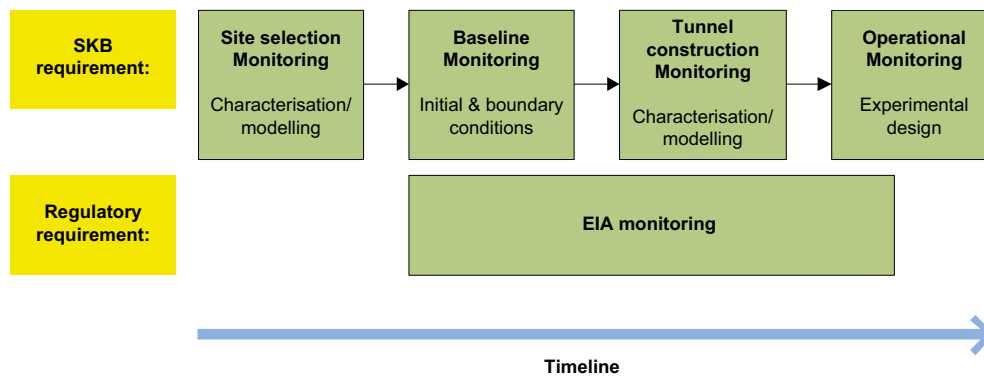

Figure 2-2. The staged approach of monitoring at Äspö.

During its operational phase the laboratory houses a number of different research experiments which are conducted simultaneously at different locations throughout the tunnelsystem. The monitoring system is critical for these several experiments for various reasons. In conjunction with the site descriptive model it provides:

- means to select an appropriate experimental site
- initial and boundary conditions for the experiment
- direct data to experiments
- means to minimize hydraulic disturbances between experiments

The monitoring of water level in surface boreholes started in 1987 and the construction of the tunnel started in October 1990. The tunnel excavation began to affect the groundwater level in many surface boreholes during the spring of 1991. A computerised Hydro Monitoring System (HMS) was introduced in 1992 and the first pressure measurements from tunnel drilled boreholes were included in the HMS in March 1992.

Objectives

The purpose with monitoring is to:

- Provide base data for tunneldrainage processes and impact on its surrounding
- Establish and follow up a baseline of the groundwater head and groundwater flow situations
- Provide information about the hydraulic boundary conditions for the experiments and modelling in the Äspö HRL
- Provide data to various groundwater flow and transport modelling exercises, including the comparison of predicted head with actual head.

Experimental concept

The monitoring system relies on a relatively large number of measuring points of various hydro-geological variables (about 1 500).

Water level and groundwater pressure constitute the bulk of the data collection where we at present record from about 400 locations mostly from the tunnel. For longterm monitoring boreholes are instrumented with up to ten pressure sections where water samples may be taken or tracers injected/circulated. The tunnel drainage is monitored through V-notch weirs at 29 locations of which water salinity is also measured at 22 stations. Hydrological monitoring of flow and salinity is performed in two streams and one meteorological station is recording wind, radiation, precipitation, pressure and humidity Surface hydrological and soil aquifers monitoring were initiated during the site investigation in Oskarshamn. Some of these monitoring stations were later incorporated into the Äspö HRL monitoring system.

Results

The monitoring system is continuously maintained and data collected. The hydrogeological monitoring system has functioned well and the monitoring points in the tunnels have been maintained. The monitoring system has provided continuous support for the experiments and projects in their planning and execution and for the tunnel activities operations.

Quality control of data is performed at different levels and scope; weekly, semiannually and annually in internal, non-public documents.

In support of the site for the coming nuclear waste repository, a transfer of knowledge and know-how from Äspö Hard Rock Laboratory to Forsmark Site administration on all aspects of hydrogeological monitoring continued. This is sustained on a structured and recurrent basis comprising technical, organisational and Q/A & Q/C issues.

Annual monitoring reports for this year were issued for groundwater and surface water respectively (SKB internal, restricted reports).

Work on improving the monitoring methodology was undertaken.

Firstly with regard to the precipitation measured at the gauge by improving the present correction model from tabulated monthly normal values based on all national precipitation stations to a model which includes more local information from each actual measurement. The method has been applied and tested for the meteorological station at Äspö and at Forsmark. Implementation is still pending.

Secondly with regard to hydraulic head where a review of its determination along with associated uncertainties was undertaken. It resulted in a detailed description of how the hydraulic head is derived, a quantification of the associated uncertainties and a number of suggestions for improvement in its determination. Implementation is still pending.

2.4 Geochemistry

Background

A general understanding of the current hydrogeochemical conditions in deep crystalline bedrock is crucial when predicting future changes in groundwater chemistry (i.e. climatic cycles).

Through different experiments and projects undertaken in the tunnel, additional data is collected and deeper understanding is gained, for example in groundwater composition, origin and evolution in the area, together with active major processes, primarily flow/mixing related, in order to explain the groundwater chemistry and its distribution.

Objectives

The major aims of the hydrogeochemical activities are to:

- Maintain and develop the understanding the groundwater composition and origin in fractures at Äspö HRL.
- Maintain and develop the knowledge of applicable measurement and analysis methods.
- Support of experiments and measurements in the hydrogeochemical field to ensure they are performed with required quality.
- Provide hydrogeochemical support to active and planned experiments at Äspö HRL.
- Provide hydrogeochemical expertise to SKB at large.

Results

Hydrogeochemical resources were largely provided to the following major projects and activities:

- Chemical characterization of organic material in deep groundwater in Äspö HRL.
- Chemical characterization of rare earth elements in deep groundwater in Äspö HRL.
- The Detailed investigation methodology project for developing hydrogeochemical methodology and instrumentation required for the construction of the Spent Fuel Repository in Forsmark.

2.4.1 Hydrochemistry monitoring program

Background

The Äspö area is equipped with numerous sampling spots specially selected for the characterisation of the local hydrogeological system, including three main aqueous environments denoted as:

- The surface environment – precipitation, stream, lake and sea water (i.e. surface water).
- The near surface environment – regolith aquifer (i.e. near surface water).
- The deep environment – water-bearing fracture network (i.e. groundwater).

The chemical and isotopic compositions of these different waters are determined on regular basis, as part of the hydrogeochemical monitoring program. Hydrogeochemical data is also collected from deep boreholes drilled along the Äspö HRL, in the framework of specific research and development projects carried out by the Swedish nuclear fuel and waste management company and its international partners.

The monitoring program is designed as monthly to annual sampling campaigns depending on the type of aqueous environment. Surface waters are collected from permanent meteorological stations, and temporary stream, lake and sea stations. Near surface waters are collected, through pumping, in shallow boreholes – also named soil tubes in the SKB literature – reaching the bottom of the regolith aquifer. Ground waters are collected in packed-off sections of percussion and core-drilled boreholes, either by pumping (subvertical surface boreholes) or by artificial drainage (subhorizontal tunnel boreholes).

Analyses take place at Äspö chemical laboratory as well as in external laboratories.

Objectives

The hydrogeochemical monitoring program aims to provide primary data for the long-term ongoing SKB research and development program and experiments in the tunnel at Äspö. This program maintains the continuity of hydrogeochemical time series started, for some of them, since the beginning of the excavation of the Äspö Hard Rock Laboratory in 1990. These time series allow a continuous improvement of the site model, which, in turn, aims to gain knowledge and ultimately predict the influence of an underground facility and its activities on the hydrogeological system. Additionally, the monitoring program provides data for external research organisations.

Results

All analytical data from 2019 are quality assured and stored in SKB database. In addition to the usual analyses, also acetate and C-13/C-14 in the organic phase were performed.

3 Research projects and development of engineered barriers

3.1 General

To develop the engineered barriers of the repositories for spent fuel and radioactive waste and to demonstrate their function, work is performed at Äspö HRL. The work comprises translation of current scientific knowledge and state-of-the-art technology into engineering practices applicable in a real repository.

Furthermore, research projects are conducted in order to develop the knowledge of the repository barriers and their function in the long-term perspective.

It is important that research, development, testing and demonstration of methods and procedures, as well as testing and demonstration of repository system performance, are conducted under realistic conditions and at appropriate scale. A number of large-scale field experiments and supporting activities are therefore conducted at Äspö HRL. There are also ongoing projects at Äspö that primarily are comprised of laboratory work in the bentonite research laboratory and the chemistry laboratory.

The experiments focus on different aspects of engineering technology and performance testing and are in line with what is addressed in SKB's RD&D programme.

During 2019 the following experiments and projects concerning the engineered barriers were ongoing, either in active or in monitoring stage:

- Drilling of deposition holes
- System design of buffer and backfill.
- Investigation methods for ramp and shafts.
- Development of concrete barriers.
- Borehole sealing.
- Bentonite material studies.
- Prototype repository.
- Concrete and clay.
- Alternative buffer materials.
- KBS-3 method with horizontal emplacement.
- Large scale gas injection test.
- In situ corrosion testing of miniature canisters.
- Long term test of buffer materials.

These projects are described in the following sections.

3.2 Drilling of deposition holes

Background

SKB has followed Posiva's development work for deposition holes, where Posiva has drilled ten vertical experimental holes in Onkalo, distributed between two demonstration tunnels (Railo et al. 2015, 2016). The deposition holes were drilled with a prototype machine of type Rhino HSP500 manufactured for the purpose. SKB has previously drilled around 15 deposition holes in the Äspö HRL with a different machine during 1998–1999 (Andersson och Johansson 2002).

There is still a need for further development and evaluation of the drilling of of deposition holes with the new prototype machine. A new project will start during 2019 and the first results are estimated during 2020–2021.

The principle layout of a deposition hole is diameter 1 750 mm and depth ca 8 000 m as seen in Figure 3-1.

Objectives

SKB will borrow Posivas prototype machine for drilling deposition holes, evaluate and if possible further develop the equipment. After that SKB will drill a new set of experimental holes at Äspö HRL, Figure 3-2.

In addition to evaluating development of the machine, the drilling of deposition holes will also be a good opportunity to update and expand SKB's experience in drilling of deposition holes as this has not been done in some time. The drilling activities will also give improved basis for calculations on cost for wear on drilling equipment.

The project is planning for transportation of the machine down in to Äspö underground laboratory. An inventory list of the machine has been made and the status of each component has been investigated. The project is preparing to install media as electric and water distribution at the work site.

An updated nominal buffer and deposition hole geometry has to be incorporated in the project.

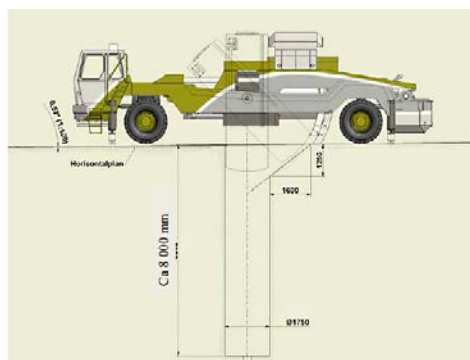

Figure 3-1. Cross section of a reference design KBS-3 deposition hole, shown here together with a deposition machine.



Figure 3-2. Prototype machine of type Rhino HSP500.

3.3 System design of buffer and backfill

Background

For detailed design of the deposition area, the designs of buffer and backfill should be updated to allow for efficient and robust installation. Decisions on new excavation method and new cross sections for deposition tunnels mean that the design of backfill must be adapted to new conditions. A well-balanced and site-adapted design of buffer and backfill is vital both in order to achieve a robust installation and to meet the requirements for ensuring post-closure safety. The project will evaluate if the buffer design can be based on buffer blocks installed as block segments. As part of this evaluation, the project comprises a full-scale, insitu test of the early THM-processes of a buffer installed with segmented buffer blocks. This test was installed during September and October 2019 and evaluation is ongoing.

The design work also includes a revision of the buffer pellet design. As basis for this design, experimental testing was carried out in Äspö's Multi Purpose Facility during 2018 and 2019.

3.3.1 Buffer pellet design

Objectives

SKB has since the installation of the Prototype repository been using a roller compacted pellet type for the buffer. In previous work, the need to optimise the pellets in order to have as robust installation as possible has been identified. The optimisation task includes identifying the desired functions for the pellet filling and testing how different pellet types can fulfill these functions. The objective of the work is to make a recommendation for the choice of a pellet design.

Experimental concept

A number of tests were carried out to be able to determine which bentonite material and which pellet type is best suited to absorb and distribute water in the pellet gap between the buffer and the deposition hole wall and, if possible, see to what extent different water inflows can be limiting for a full-scale installation.

The tests were performed in a laboratory environment where possible water inflows into the buffer's pellet-filled gap were mimicked. The test equipment consisted of a test box fitted with a transparent plexiglass (1 m × 1 m), see Figure 3-3.



Figure 3-3. Test box.

The box was filled with a 5 cm thick layer of pressed buffer blocks and a 5 cm thick layer of pellets. The pellets had access to a constant water flow through an inflow point placed in the middle of one plexiglass plate. The reference set-up for the experiments was as follows: a point inflow of 0.01 l/min and compacted Wyoming bentonite (Barakade). The test matrix (see Table 3-1) was then based on variation of water inflow, point and fracture inflow as well as materials and pellet type. In addition to Wyoming bentonite, Bulgarian bentonite (CaBen) was tested for buffer pellets. The blocks in the tests were made from Wyoming bentonite (Barakade). The plexiglass side with pellet filling was photographed continuously to see how the water progressed through the pellet filling. The water ratio and density of the bentonite materials were determined before installation and after dismantling of the tests.

Table 3-1. Test matrix.

Test #	Material	Pellet type	Water flow (l/min)	Inflow shape
1*	Barakade	Roller-compacted	0.01	Point
2*	Barakade	Roller-compacted	0.01	Point
3	Barakade	Extruded	0.01	Point
4**	CaBen	Roller-compacted	0.01	Point
5**	CaBen	Roller-compacted	0.01	Point
6***	CaBen	Extruded	0.01	Point
7	Barakade	Roller-compacted	0.001	Point
8	Barakade	Roller-compacted	0.1	Point
9	Barakade	Roller-compacted	0.01	Fracture, vertical
10	Barakade	Roller-compacted	0.01	Fracture, horizontal

* Reference set-up. The test was repeated.

** A variation of the reference set-up with a different material. The test was repeated.

*** For test #6A, the photo documentation was interrupted. The test was repeated under the name 6B.

Results

The evaluation of the tests was based on the following:

- How water was distributed in the pellet filling. The water ratio for samples from the pellet filling and the centre block are compared for the different tests.
- A visual analysis of the photo documentation at defined times.
- Measurements of water pressure for the inflowing water.

An example of a photo series is presented in Figure 3-4.

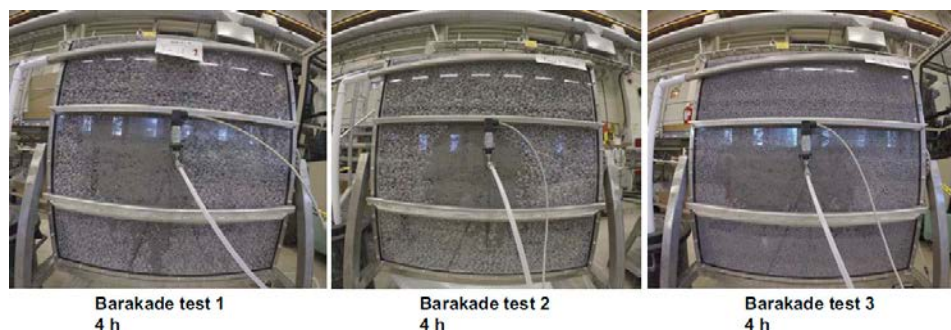

Figure 3-4. Examples of the photo documentation for three different tests with Barakade material after 4 h test time.

The complete evaluation is published in Lundgren and Johannesson (2020) and can be summarized as follows:

- The differences between the pellet types tested in this study are small.
- Choice of material seems to be the factor that most influences the pellet's ability to buffer water.
- Less crucial seems to be the type of pellets (compacted and extruded, respectively).
- There is no difference between the investigated pellets' ability to prevent water from reaching and affecting the bentonite blocks inside the pellet filling.
- It cannot be excluded that the water content of the materials can have a decisive influence on how the pellets serve as a filling. This has not been investigated here.
- Only one size of extruded pellets and one size of compacted pellets have been used in the experiments. This means that conclusions regarding the effect of the pellet dimensions on the results cannot be made.

3.3.2 Early THM processes in the buffer

Objectives

The purpose of the full-scale buffer test is to better understand and model the buffer's early thermal, hydraulic and mechanical evolution. The gained knowledge and updated models will be used to better plan the installation sequence for the buffer in deposition holes with different water inflows. The results from the test and subsequent modelling will also be a part of the evaluation of the buffer concept with segmented buffer blocks.

Experimental concept

The early THM processes in a buffer installed as segmented blocks are studied in full scale in the CRT deposition hole at Äspö.

Test design: The test comprise the buffer blocks installed in 34 layers and a full scale canister with heater generating 1 700W (see Figure 3-5). The layers are built by block segments according to Figure 3-6. The gap between the block and the deposition hole walls is filled with roller compacted pellets. The buffer will absorb water from water-bearing fractures in the deposition hole wall. The uppermost top layer is covered with an insulated, diffusion-tight lid. The lid allows for measurements of the top layer level and visual inspections through drilled holes.

Material: The bentonite material used for both blocks and pellets is a naturally sodium dominated clay from Wyoming, USA.

Instrumentation: The test is instrumented with around 130 thermoelements and 15 RH sensors. The thermoelements are placed in the buffer and the surrounding rock. All instrumentation is placed in 4 perpendicular directions. No sensors are placed in or near the joints between blocks.

Monitoring: A likely outcome is deformation both axially and radially. During the running of the test, the top surface level is measured at least weekly. Sensor data is logged every 15 minutes. The function of the heater and the sensors' function are monitored continuously.

Sampling and analysis: The test will be sampled during dismantling and analysed for water content and density.

Test time: The test will run for 90 days. Dismantling, sampling, analysis and evaluation will take place during the first half of 2020. The results will be published.

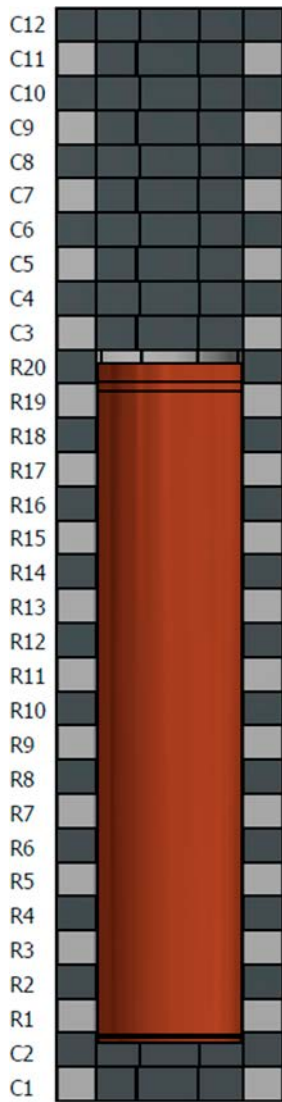

Figure 3-5. Canister and blocks in the full scale test with segmented buffer blocks.

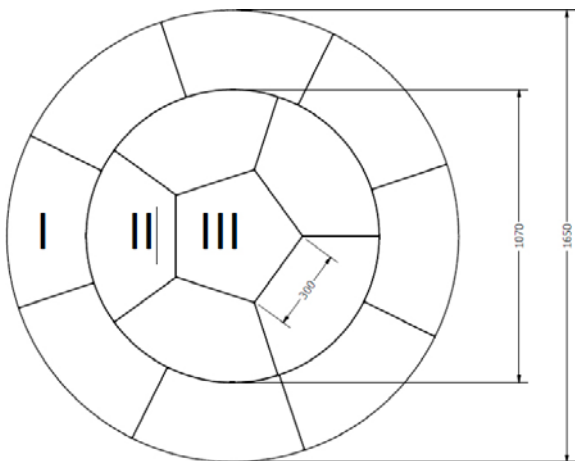

Figure 3-6. Block layer layout for layers over and under the canisters (denoted C in Figure 3-5). The layers of blocks surrounding the canister (denoted R in Figure 3-5) include only the outer block ring, 8 blocks in total.

The following photos show the test during installation. Figure 3-7 shows the installed blocks and pellets just before deposition of the canister. Figure 3-8 shows the test with the canister in place. Finally, Figure 3-9 shows the installation when completed (before placement of the protective lid).



Figure 3-7. Buffer blocks and pellets installed to the canister's top level.



Figure 3-8. Test installation after deposition of the canister.



Figure 3-9. Test after completed buffer installation but before placement of the lid.

Results

The results from the full scale buffer test are being processed at the time for writing this year's Annual Report. The results will be reported as part of the documentation from the project.

3.4 Investigation methods for ramp and shaft

Background

Detailed studies are necessary to characterize and document the Forsmark bedrock before the production of the Spent Fuel Repository so that it is constructed in accordance with conditions in the bedrock, and construction requirements regarding rock can be verified.

During autumn 2016 it was decided that technology project DETUM-1 should be discontinued and the remaining work within DETUM's subproject *Methods and Instruments (M & I)* would be transferred into the new project KBP5003 Methods for investigations, for further development.

The project will complete technology development of methods for investigations for the Spent Fuel Repository accesses (ramp and shaft) in accordance with established list of investigation equipment.

Developed methods will ensure that the detailed investigations efficiently provide the data required for the safety assessment and the repository construction with regards to cost and time.

The project will develop documentation for methods that will guide the performance of investigations in the Spent Fuel Repository (ramp and shaft).

Output targets

The target is to ensure that all survey methods, document management and instruments needed to implement detailed investigations for the Spent Fuel Repository accesses are presented, described, quality assured and approved when it is time for the operational programs being submitted to the Swedish Radiation Safety Authority, this in connection with the application to commence construction of the Spent Fuel Repository.

Results

Geology

The work concerns primarily RoCS, a digital system developed by SKB for geological mapping of underground openings (tunnels, shafts and niches, etc.). The system basis is a photogrammetric mapping record (3D model) upon which the spatial extent of various geological features is digitized. Geological properties of the digitized features are provided by studies of the rock surfaces of the underground openings.

The use of RoCS for regular tunnel mapping during the Äspö HRL expansion project, as well as subsequent workshops with various experts and end-users, have revealed a demand for additional adaptation and development of the system before full application. Aspects of special focus include both functions of the RoCS mapping module and the process for generation of photogrammetric 3D models. To provide support for this work, a series of tests have been completed within the framework of the laboratory. For the photogrammetry, this includes the following components:

- Camera and light setups for photography of deposition tunnels and repository skip shaft by tests in TAS04, TASH and TASS. An important parameter for evaluation was the time required for the sequence of setup, photography and generation of photogrammetric models.
- Completion of method description SKB MD 150.011 for photogrammetry.

The development that covers the mapping method and the functions of the RoCS mapping module, has included the following work:

- Tests in TAS04 with comparative mapping for evaluation of a remote mapping technique and the impact of work routines and interpretations developed by different geologists.
- A continued updating of the mapping module, primarily regarding the handling of fracture data, which was initiated during 2018.
- Completion of a draft version for method description SKB MD 150.010 for mapping with RoCS.

Another issue addressed the past year has been to develop a measurement method that is able to verify that the deposition holes fulfil the geometrical requirements. The focus in this work has been to rely on laser techniques. Various tests have been completed in deposition hole DO0010G01, see Figure 3-10, but a final decision on the choice of technique is not yet settled. The most promising approach so far is the use of a high-precision scanner lowered from a rigid tripod, placed immediately above the hole. Tests accomplished during 2019 focused on the following issues and evaluation is still in progress:

- Instrumental vibrations.
- Character of the bedrock surface, in terms of mineralogy, roughness and dampness.
- Merging of point clouds from different scan levels.



Figure 3-10. Scanning of deposition hole DO0010G01 with a Trimble TX8 Laser mounted on a fixable tripod rig to minimize instrumental vibrations.

3.5 Work on concrete barriers

Background

The final repository for low and intermediate level radioactive waste, SFR, located in Forsmark, has been in operation since 1988 and has been operated since 1 July 2009 by Svensk Kärnbränslehantering AB, SKB. The repository is located in rock vaults 50 meters below the sea bed of the Baltic Sea, and stores waste from Swedish nuclear power plants as well as from health care and industry.

The existing facility is designed for final disposal of mainly operational waste from the Swedish nuclear power plants. At present, an extension, SFR3, of the repository is being planned to facilitate disposal also of the waste that will arise during the dismantling of the Swedish nuclear power plants. In this extension, a waste vault for intermediate level radioactive waste, 2BMA, will be included, Figure 3-11. The repository structures in 2BMA consist of unreinforced concrete caissons, Figure 3-12.

In order to demonstrate that SKB is able to construct the concrete caissons in accordance with requirements under current prerequisites a development program comprising a number of different development and verification steps has been conducted. This development program has included the steps from material development through casting of a concrete caisson with all the design elements of the full scale caissons in the future 2BMA in the Äspö Hard Rock Laboratory and monitoring of its properties.

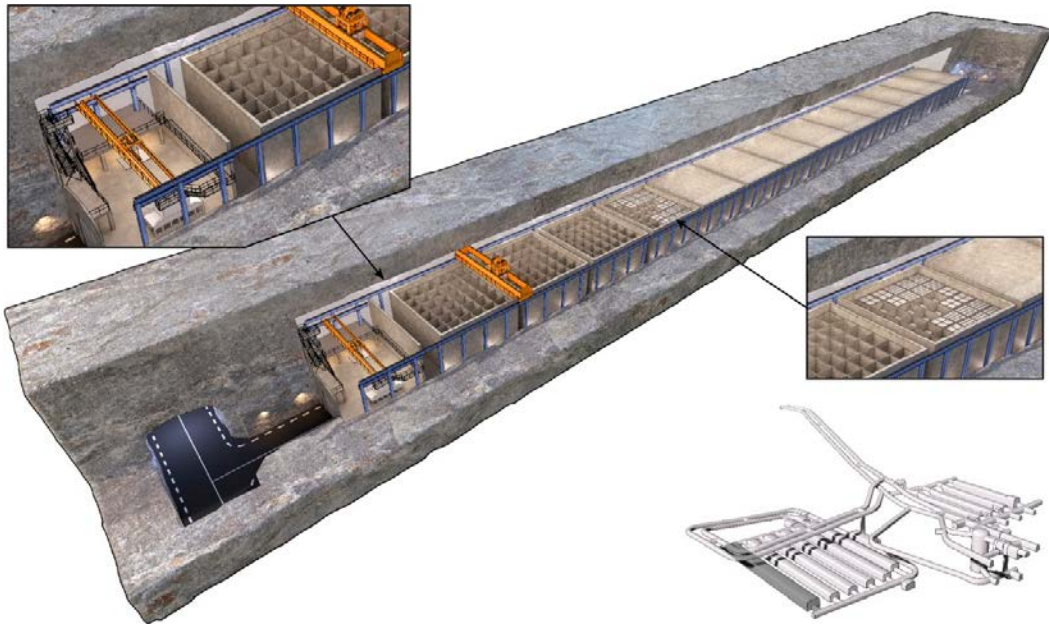

Figure 3-11. The waste vault for intermediate level radioactive waste, 2BMA.

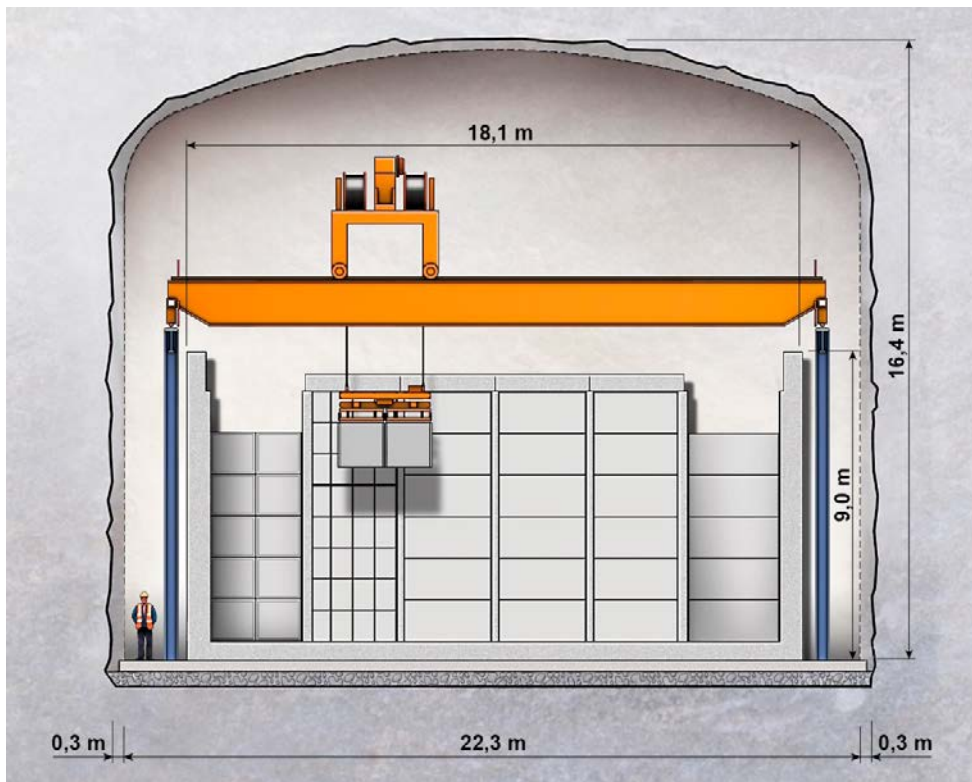

Figure 3-12. A schematic illustration of a cross section of a concrete caisson for 2BMA.

Objectives

The main objective of this development programme is to demonstrate that SKB is able to construct the concrete caissons in accordance with requirements under current prerequisites.

Experimental concept

The program has included the following main steps:

- Characterization of the bedrock in the area of the future SFR3 and identification of suitable quarries that can be used for production of concrete aggregates to be used during the material development work. Previously reported in Lagerblad et al. (2016).
- Material development, including laboratory work, up-scaling to production scale, transport simulations and pump tests. Previously reported in Lagerblad et al. (2017).
- Casting of a representative section of a concrete caisson in TAS05 in the Äspö HRL according to the reference method valid at that time as well as according to a more standardised method and long-term monitoring of its properties. This part also included a stress test where the concrete structure was covered in a tent-like structure and dehumidifiers installed to reduce the humidity in the atmosphere surrounding the concrete structure. Reported in Mårtensson and Vogt (2018)
- Casting of a concrete caisson according to the new reference design adopted in 2017 in TAS08 in the Äspö HRL and long-term monitoring of its properties.

Results

For results from the first two parts of the material development programme, please refer to Lagerblad et al. (2016 2017).

For results from the casting of representative sections of a concrete caisson in TAS05, please refer to Mårtensson and Vogt (2018).

During the autumn 2018 a concrete caisson with the dimensions 18*9*4.5 m was constructed in TAS08 in the Äspö laboratory. The thickness of the base slab and the walls were 0.60 and 0.68 m respectively and no reinforcement was used. The interior of the caisson is shown in Figure 3-13.

The work included the following 4 main activities which were briefly summarised in SKB (2019b):

- Preparations in TAS08.
- Establishment of a mobile concrete production plant.
- Casting of the base slab of the caisson.
- Casting of the walls of the caisson.

During 2019, the concrete caisson has been monitored with focus on temperature, relative humidity, levels of internal strain and external dimensions. Also weekly visual inspections have been carried with main focus on the presence of cracks.

Most importantly the monitoring has shown that the levels of strain in the concrete caisson are very low and also that no cracks have formed during the first year after casting. As expected, changes in temperature and relative humidity have been very small and followed the seasonal climate changes in the tunnel. All details concerning experiences from casting as well as data and interpretation of data from the monitoring programme are presented in Mårtensson and Vogt (2020).

Beginning spring 2019 the development programme was extended to also include investigations of methods to remove the plastic tubes used to protect the tie rods in the wall formwork and to fill the holes with a cement grout with a low hydraulic conductivity.



Figure 3-13. The interior of the concrete caisson after dismantling of the formwork.



Figure 3-14. The images show the protective tube left in the concrete (left image) and during extraction.

The following conclusions were made during this work:

Extraction of the plastic tubes by means of any of the methods tested had a rather low capacity and in some cases it was not possible to extract the tubes in spite of large efforts being made. None of the methods used was therefore considered suitable for use during construction of the concrete caissons in the future 2BMA and other materials in the protective tubes or methods to remove them have to be sought for.

Grouting of the holes using a spray boy was efficient and had a high capacity. The hardened grout filled the holes entirely but the porosity of the grout was rather high which was also reflected in a high hydraulic conductivity of the grouted holes, Figure 3-15.

From the results it can be concluded that grouting of the holes can be done with a high capacity but that the hydraulic conductivity of the grouted holes does not comply with requirements. Further development work will thus be required if tie rods are to be used in formwork during construction for the 2BMA caissons. For further details on this work, please refer to Mårtensson and Vogt (2020).



Figure 3-15. Cross section of a grouted hole. Note the presence of a large number of voids in the grout.

3.6 Sealing of boreholes

Background

A large number of investigation boreholes have been drilled in both the area for the planned Spent Fuel Repository and for the Final Repository for Short-Lived Radioactive Waste (SFR) which are both located in Forsmark in Östhammar municipality. While some of these boreholes will be used for monitoring during the construction others need to be sealed before the start of the construction of the above ground facilities and the start of the excavation work.

The previous reference method for sealing these investigation boreholes (SKB 2010) was to install highly compacted bentonite plugs placed in perforated copper tubes in the main part of the borehole while the parts of the borehole that includes water bearing fracture zones will be filled with quartz based concrete plugs that prevents erosion of the clay. The drawback with this method is that it is very expensive and labour intensive. A new technology develop project was therefore initiated in 2015 with the goal to optimize the sealing of SKBs investigation boreholes in Forsmark. The main changes in pre-conditions compared to previous work was:

1. The previous reference method was mainly developed for sealing of deep investigation boreholes with a hydraulic connection to the repositories. There was a need for a diversified sealing methodology as most of the investigation boreholes are shallow and/or located far from the repository area. The new method developed therefore was optimized for managing both deep boreholes and the many shallower boreholes in an efficient manner.
2. Analyses performed within SR-Site regarding the Spent Fuel Repository (SKB 2011) shows that the previous requirement on a low hydraulic conductivity could be changed to allow a higher hydraulic conductivity. The effect of nearfield hydrology for SFR has been studied with hydraulic modelling (Abarca et al. 2013). The conclusion of this modelling is that boreholes should be sealed with a method that results in a hydraulic conductivity of 10^{-6} m/s or lower. This creates a ground water flow through the repository that is the same as if no boreholes were present. A study regarding closure of ramp, shafts and investigation boreholes for the spent fuel repository has shown that the current requirement, i.e. that the sealing needs to restore the hydraulic conductivity of the rock, is unnecessarily high. A new design requirement regarding borehole sealing at the Spent Fuel Repository in Forsmark has therefore been recommended where the hydraulic conductivity of the sealing along the borehole length is less than 10^{-6} m/s (Luterkort et al. 2012).

A new design for sealing deep boreholes has been developed, based on the updated design requirements. This method, referred to as "the sandwich concept" (Figure 3-16), is developed for sealing of deep investigation boreholes with a hydraulic connection to the repositories. The method is however modular and can easily be adapted to any of the different type of boreholes commonly seen in Forsmark:

- Short investigation boreholes not penetrating the rock will only use the top most part of the concept; the Bentonite pellets.
- Regular boreholes without a hydraulic connection to any of the repositories will be sealed using either a sand- or quartz concrete-filling combined with the upper end seal and bentonite pellets.
- Boreholes with a hydraulic connection to any of the repositories will be sealed with the complete sandwich concept including at least one bentonite seal.

The sandwich concept implies that the main part of the borehole is filled with sand. The purpose of the sand filling is to ensure the mechanical and chemical stability of the borehole and to create a solid foundation for the rest of the sealing components. The sealing of the borehole is done by installing highly compacted bentonite in strategically selected sections with good rock i.e. no fractures or rock fallouts. Quartz-based concrete plugs are placed as separators between the different materials. This material is also placed in borehole sections passing close to the repository and as an upper end sealing. Copper expanders are placed at all material transitions in order to prevent interaction between the materials and to ensure long-term stability. Finally, the upper part of the borehole passing the top soil is filled with bentonite pellets.

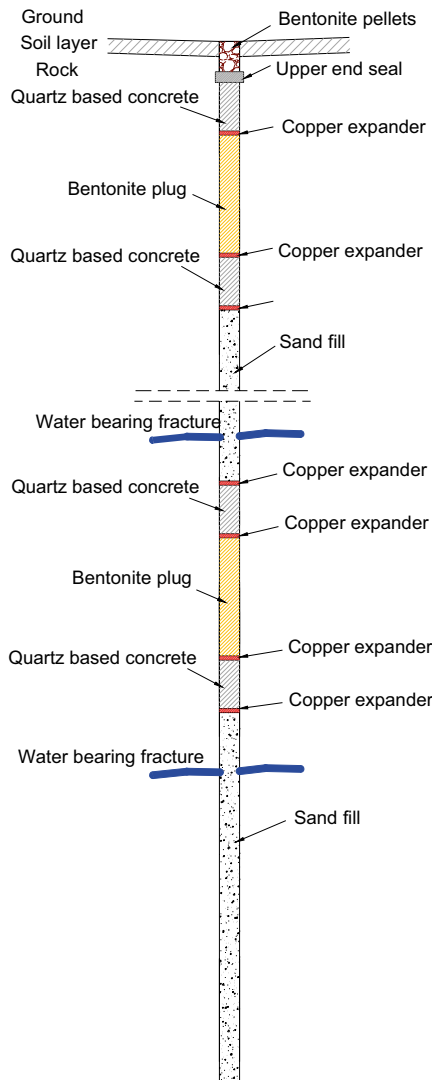

Figure 3-16. Schematic drawing of the suggested principle for sealing of deep investigation boreholes, the so called “sandwich concept”. The design includes dense bentonite plugs positioned in sections with good rock. Permeable sand is filling up the main part of the borehole. Quartz based concrete is positioned in the transition zones between bentonite and sand. Copper expanders are positioned at all transitions between different materials.

Objectives

The main objectives with the project are:

- To investigate the properties of the different sealing components included in the sandwich concept by performing small scale laboratory tests.
- To develop and demonstrate the installation technique for different sealing components. Pretests were performed in both laboratory and in field.
- To perform a sealing of a full-scale borehole using the sandwich concept. The main objectives with this test were to demonstrate the installation technique of different sealing components in full scale and to test the suggested quality control system regarding e.g. achieved density and position of the different components in the borehole.

Except for the objectives mentioned above, it has also been a goal to perform an inventory of all boreholes together with a classification. This work is, however, still ongoing.

Experimental concept

Laboratory tests were performed to test and demonstrate the installation of the different sealing components but also to measure and demonstrate the swelling pressure built up and the sealing effect of dense bentonite. Installation tests in large scale were performed in the Multi Purpose Facilities at Äspö. The tests included installation of both bentonite pellets and sand in an artificial borehole with a length of ten meters. The tests were made at both dry and wet (water filled simulated borehole) conditions. Furthermore, tests were made to install concrete in a simulated borehole with the use of standard drill tubes.

After finalizing the preparatory tests, a full-scale installation test demonstrating the sandwich concept, was performed.

Samples were taken of the concrete at the lower part of the installed sealing (the concrete part)

Further development of the sandwich concept has been performed. This work was focused on simplifying the concept and to make it more cost efficient.

Results

The different components included in the sandwich concept, the sand, bentonite, concrete and the copper expander have been tested at the Bentonite Laboratory in Äspö and at Clay Technology during 2017. The results from these investigations are reported in Sandén et al. (2017). The results from these laboratory tests were then used as input for the design of both a mock-up test and the upcoming field test at Äspö.

The mock-up test, which includes all the components in the sandwich concept, see Figure 3-17, was installed and retrieved during 2017. This test was preceded by tests made in the laboratory where the homogenisation of the bentonite was studied. The saturation and the hydraulic conductivity of the installed bentonite were measured. This information was complemented with measurement of the achieved final density of the installed bentonite after the dismantling of the test. The result of the mock-up test is reported in Sandén et al. (2018).

The borehole KAS013 at Äspö, which has a diameter of 75 mm with a total length of ca 250 m, was decided to be used for a first test installation of the sandwich concept at full scale. The borehole starts at the island Äspö and ends at the -220m level in the Äspö tunnel. The choice to use a hole that is open in both ends was made to support future tests and possible overcoring of the installed lower parts of the borehole seal. The preparation of the hole was made at the end of 2017 which included changing of the casing in the upper part, reaming and cleaning of the hole. This work was made with a drill rig from the ground level. The installation of the sandwich concept was done in June 2018 and it was performed as a pure installation test.

The installation included several different components: a special developed concrete with a very low cement content, a standard concrete, sand, highly compacted bentonite and copper expanders (bridge plugs). The sand was installed by gravity (controlled installation rate) while the installation of the other components required access to the drill rig. The installation went according to plans and the techniques developed and tested in laboratory also proved to work in full scale. The total installation time was approximately two weeks.

To ensure the quality of the performed work it was necessary to have a detailed quality plan that included: organization, available borehole data, preparatory work, drilling rig, material data and a controlled installation procedure. The quality of the borehole sealing was assessed to be successful regarding e.g. achieved density of the bentonite section as well as in the two sections filled with sand. Regarding the concrete sections, there was a difference between the injected volume and the filled borehole volume for two out of the five concrete sections. The difference was believed to depend on problems to fill the injection tubes properly i.e. there may be trapped air in the concrete which means that the injected volume was overrated. The installation test is reported in Sandén et al. (2018).

The KAS13 borehole crosses the tunnel ramp close to the elevator shaft at the –220-meter level. This means that it is possible to have access to the lower part of the borehole. It was planned to over core the lowest five meters of the borehole from the bottom to be able to take out samples and study the quality of the installed components i.e. two types of concrete and one copper expander. This activity was done during the spring 2019. The results of this study indicated that the standard concrete worked well, i.e. the hardened concrete filled the hole completely and was homogeneous while the specially designed concrete (SKB concrete see Figure 3-17) had been separated during casting resulting in parts of the plug consisting of only ballast. The examination of the installed copper expander shows that some expansion of it was obtained at the installation. However, due to damage to the expander at the core, it was not possible to fully test its function, e.g. by loading it or measuring its final diameter afterwards.

New equipment for installing concrete in a borehole was tested on a relatively large scale at the laboratory at Äspö in the fall of 2019. The equipment consists of a concrete mixer with an integrated pump for pumping the concrete. Tubes with lengths of 6 m and diameters of 160 mm were filled with mixed standard concrete from the equipment. Tests with initially both dry and water filled tubes were made. After the concrete was hardened the tubes were cut in halves and the concrete was examined concerning its homogeneity. The results indicate that it is possible, with the use of the suggested equipment, to achieve acceptable concrete casting inside a bore hole.

A further development of the sandwich concept was initialized at the end of 2019. This work includes more tests on the sand and suggestions of simplifications of the concept. This work will be reported during 2020.

Depth, m	Material	Remark
0-102	na	na
102-102.5	Plug d=76/96 mm, concrete	SKB-type
102.5-102.6	Copper expander	
102.6-170	sand	<2mm
170-170.1	Copper expander	
170.1-175.1	Concrete	SKB-type
175.1-175.2	Copper expander	
175.2-185.2	Bentonite	MX-80
185.2-185.3	Copper expander	
185.3-190.3	Concrete	SKB-typ
190.3-190.4	Copper expander	
190.4-232.3	sand	<2mm
232.3-232.4	Copper expander	
232.4-252.4	Concrete	Standard
252.4-252.5	Copper expander	
252.5-253.5	Concrete	SKB-type
253.5-254	Plug d=76/96 mm, concrete	SKB-type
254-255-	Concrete	SKB-type
255-	Mechanical packer	Bottom of the borehole

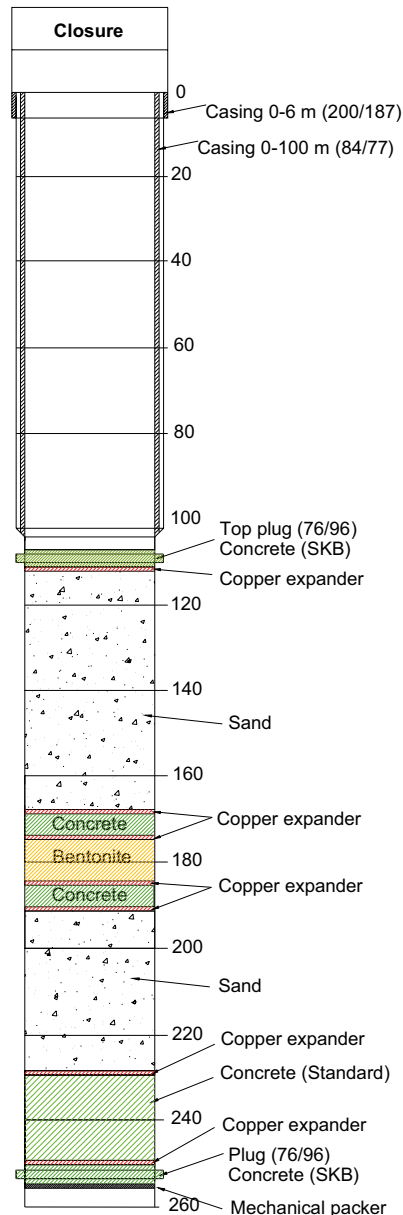

Figure 3-17. Schematic drawing showing the planned position of the different sealing components for borehole KAS13 at Äspö.

3.7 Bentonite material studies

Background

SKB has developed methods and techniques for acquisition and quality control of bentonite for a long time (Svensson et al. 2017). The work is conducted in the Material science project.

The long term safety requirements on the bentonite are ensured by a number of technical design requirements (TDRs). The following TDRs are considered; swelling pressure, hydraulic conductivity, shear strength, thermal conductivity and limitations in sulphide, total sulphur and carbon (harmful substances) (Posiva SKB 2017).

In order to develop in-house knowhow, improve flexibility and make cost-efficient bentonite sampling and characterisation, SKB has opted to set up its own laboratory at Äspö.

Different methods will be needed at different stages of the future process. Three different characterisation levels are currently suggested, see Table 3-2.

The extensive material characterisation is essential for the approach of an adaptive buffer and backfill design, where the dry density and water content of the blocks and pellets are adjusted based on the material characteristics, in order to fulfil the in situ requirements and allow for efficient industrial production.

Both the listed methods and characterisation levels will be updated when more experience and statistics are available. Characterisation level 1 is aimed at basic acceptance data that can be measured relatively quickly. Characterisation level 2 is more time-consuming and provides the basis to develop an adapted design. Characterisation level 3 is directly connected to the quality of the final blocks and should confirm the components' quality.

Table 3-2. *Characterisation methods under development at the Äspö material laboratory.*

Level	Parameter	Comment
Characterisation level 1		Level 1 should provide basic acceptance data
1a	Water content (water/dry mass) Granular size distribution	1a) Includes process steering parameters.
1b	Chemical composition (XRF) Swelling pressure, quick Cation Exchange Capacity (CEC) Combustion analysis, (C_{org} , S_{tot} , $S_{sulfide}$)	1b) Includes methods aimed at confirming acceptable homogeneity in the material. Currently external
Characterisation level 2		Level 2 should provide the basis to develop an adapted design
	Hydraulic conductivity and swelling pressure Exchangeable cations (EC) Mineralogical composition (montmorillonite) XRD Grain density Compaction properties Unconfined compression strength Thermal conductivity	Currently external Currently external
Characterisation level 3		Level 3 should confirm the component quality
	Pellets, dimensions and abrasion resistance Block dimensions, weights and visual inspection	Under development

A large benefit in establishing analysis methods for the suggested parameters at Äspö and in SKBs central management system is that when a laboratory is built in Forsmark, the methods will already be available in the management system and verified in the laboratory and it will be possible to apply plenty of knowledge and routines from Äspö to establish selected methods in a new facility.

Objectives

The objectives of the Material science project are:

- To ensure that SKB has the material knowhow and measurement technology needed in order to conform to the safety functions, performance targets and technical design requirements.
- To develop and test the adaptive buffer and backfill design methodology
- To verify that a quality-controlled buffer and backfill manufacturing can be accomplished with different bentonite materials
- To deliver basic data and requirements to the detailed planning of Hargshamn and to the production facilities regarding the handling and quality assurance of buffer and backfill components.

Experimental concept

The project is updating and adding to the methods listed in Table 3-2. The updates also include measurement uncertainty calculations. When finalised, the methods will be transferred to the chemistry laboratory for continuous application and administration within SKBs management system.

In parallel with the method development, the project is also assessing and updating the material evaluation process by analysing 6 different bentonites as potential buffer and/or backfill materials. All steps, from assessing the mines capabilities, full initial characterisation of a 20-200 kg sample, preliminary design, purchase and confirming analyses of 20 tons followed by full scale production and detailed design.

Other key areas of research are to study how the swelling pressure and hydraulic conductivity correlates with the content of the material and how well contaminations or other deviations can be detected. These studies are done by adding controlled amounts of sand to the bentonite and measuring the swelling pressure and hydraulic conductivity as well as other key parameters (Svensson et al 2019).

Several of the measurements are quite time-consuming which puts practical limitations on how many samples that can be analysed. SKBs strategy is to do an initial, full characterisation, of a given material, and then, based on this, define limits for some key parameters that can be continuously monitored (Svensson et al. 2017). Measurements in the laboratory will be required and measurements that have the potential to be automated, such as XRF analyses, component dimensions and weights, are of highest interest.

Assessing the variability, i.e. the heterogeneity of the material in larger purchases will be a key question for future industrial applications, when thousands of tons of materials are purchased. The current sampling strategy for a full scale test production, material purchase (~20 tons), is to take 20 samples of which one smaller parts is kept separate and analysed for variability using XRF while the larger parts are combined into a composite sample that in turn is separated into one part for laboratory analyses and one for archiving. If the purchase is 20 big-bags, each of them are sampled, while if it is 40 big-bags every other big-bag is sampled.

Results

During 2017-2019 the methods have been updated and analyses of the 6 selected materials; Milos clay, a Moroccan clay, Bulgarian clay, Turkish clay, Wyoming clay and Indian clay have been carried out together with adaptive design work and buffer block manufacturing.

Detailed data from the analyses are presented in the report *Development and testing of methods suitable for quality control of bentonite as KBS-3 buffer and backfill* (Svensson et al. 2019) and adaptive design work for the studied materials are reported in the report *Strategy, Adaptive Design and Quality Control of Bentonite Materials for a KBS-3 repository* (Kronberg et al. 2020). Buffer block manufacturing for three of the materials is reported in *Manufacturing of large scale buffer blocks* (Johannesson et al. 2020).

Table 3-3 summarises the status of the materials after the full initial characterisation with respect to their possibilities to fulfil the TDRs. Buffer made out of six of seven materials has the potential to fulfil the TDR's. The only material which did not fulfil the TDRs was Milos. However, it was bought as a lower montmorillonite content material.

With respect to the process steering parameters none of the materials fulfil the granular size specification entirely, although BARA-KADE and Sardinia are very close. For compaction in full scale the Turkish material (powder) had too low initial bulk density for fitting in the current mould and press. The Indian bentonite was also in powder form, with low initial bulk density, but possible to fit in the mould and press.

Table 3-3. Summarised status of the materials after the initial characterisation, Y = Yes, acceptable, N = Not acceptable, C=Close to limit/not ideal.

Material	Technical design requirements					Process steering parameter (with current equipment)			SKB Guidance
	C_{orig} $S_{sulfide}$	Dry density yielding acceptable pressures	Dry density yielding acceptable hydraulic conductivity	Dry density yielding acceptable shear strength	Dry density yielding acceptable thermal conductivity	Granular size	Water content	Compaction properties	Montmorillonite
Milos*	C	Y	N	Y	Y	C	Y	Y	N
Morocco	Y	Y	Y	Y	Y	C	Y	Y	Y
Bulgaria	Y	Y	Y	Y	Y	C	Y	Y	Y
Turkey	Y	Y	Y	Y	Y	C	Y	N**	Y
India	Y	Y	Y	Y	Y	C	Y	C	Y
Sardinia	Y	Y	Y	Y	Y	Y	Y	Y	Y
BARA-KADE	Y	Y	Y	Y	Y	Y	Y	Y	Y

* Purchased as a lower montmorillonite content material, other Milos materials can be adapted to fulfil all TDRs.

** The Turkish material has to low bulk density for the current mould, with another granular size it should work (current delivery was fine powder).

Since there are margins to most of the TDRs except for the swelling pressure it is generally the dry density yielding a swelling pressure >3 MPa and < 10 MPa, which is determinant for the adaptive design work.

The measured swelling pressure data was thus used to calculate exponential curves for all of the materials, which in turn was used to calculate the dry densities corresponding to 3 MPa (CaCl₂ 1M) and 10 MPa (deionized water). Figure 3-18 illustrates an example for the Moroccan material which has a possible adaptive design window between 1 441-1 550 kg/m³.

By iterating buffer block and ring starting dry densities towards a value corresponding to 10 MPa (via the swelling pressure curve), a suitable adapted design can be suggested. For the Moroccan material, a dry density of 1 695 kg/m³ for rings and 1 650 kg/m³ for blocks gives the swelling pressures in Table 3-4 which is presented together with the corresponding results for the other materials. The reason for adapting the design towards the higher part of the design window is that the processes which can affect the dry density and swelling pressure in the deposition hole, such as erosion, mineralogical alteration and buffer expansion (upward swelling) will all lower the swelling pressure.

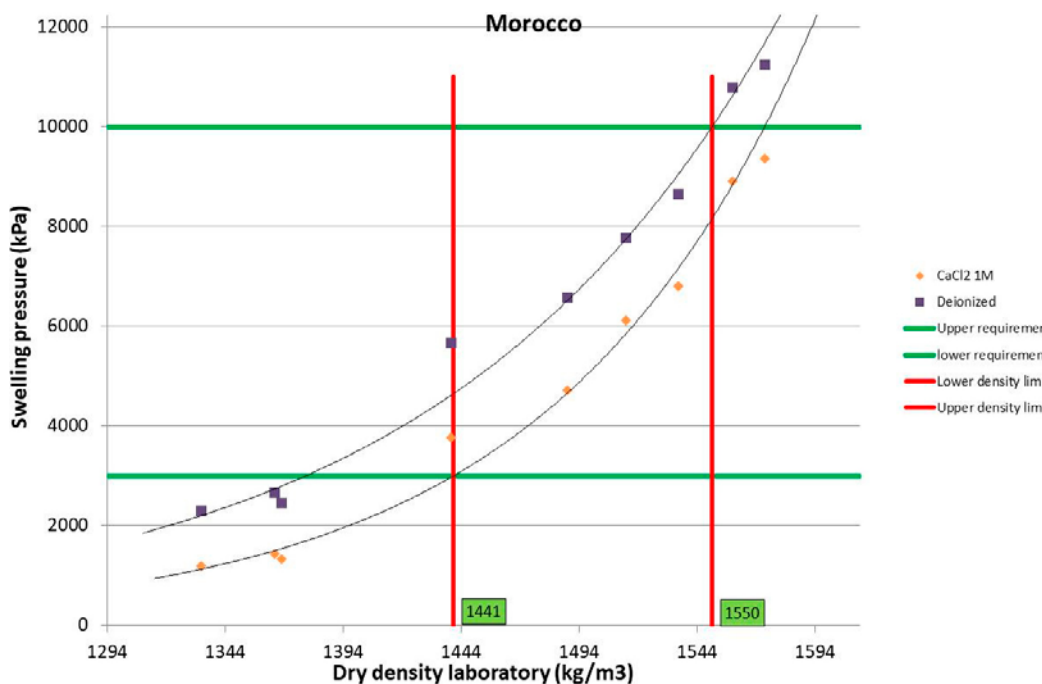

Figure 3-18. Swelling pressure vs dry density for the Moroccan material, with deionized water and CaCl₂ (1M).

Table 3-4. Calculated, average dry densities with corresponding maximum and minimum swelling pressures for adapted ring and block dry densities.

Material	Rings dry density (kg/m ³)	Blocks dry density (kg/m ³)	Installed dry density average (kg/m ³)	Stdav	Installed dry density min*** (kg/m ³)	Installed dry density max*** (kg/m ³)	Swelling pressure min, 1 M CaCl ₂ (kPa)	Swelling pressure max, Detonised (kPa)	Rings, compaction pressure (MPa)	Blocks compaction pressure (MPa)
Morocco	1695	1650	1544	3.0	1538	1550	7 320	10 000	40	30
Bulgaria	1530	1530	1418	2.8	1413	1424	7 980	9 940	30	30
Turkey**	1730	1675	1571	3.0	1565	1577	7 200	9 950	60	40
India	1669	1669	1533	3.0	1527	1539	8 420	9 970	30	30
Sardinia	1634	1630	1503	2.9	1497	1509	6 510	9 980	25*	25*
BARA-KADE	1730	1700	1576	3.1	1570	1582	7 100	10 000	53	30

* 25 MPa is below what has been tested in full scale, but likely possible based on lab scale.

** The Turkish material studied had a too low bulk density for the current mould, but it is included anyhow, as it is only a question about the granular size purchased.

*** Calculated with 95 % confidence interval.

Once the dry densities of the blocks are defined, the compaction curve, Figure 3-19, can be used to calculate the required pressures for compacting the blocks. A proven water content level, which gives good blocks was selected, 17 % in this case. For the Moroccan material, the compaction curve gives a compaction pressure of approximately 40 MPa for 1 695 kg/m³ (rings) and 30 MPa for 1 650 kg/m³ (blocks).

Three of the materials were selected for full scale production, the Indian, Bulgarian and BARA-KADE. Larger volumes (~20 tons) of the materials were purchased and a confirming characterisation was made (Svensson et al. 2019).

Using the compaction curves, the compaction pressures were calculated, Table 3-5.

Table 3-5. The planned compaction pressure and load at compaction with the conical shaped mould together with the expected dimensions, mass and bulk density of the compacted blocks (Ring and Solid blocks) (Johannesson et al. 2020).

Type	No	Material	Watercontent (%)	Compaction-Pressure MPa	Expected outcome from the pressing				
					Height (mm)	D1 (mm)	D2 (mm)	D3 (mm)	Bulk density (kg/m ³)
Solid	3	BARA-KADE 2017	17	30	500	1776	1800	0	1989
Ring	3	BARA-KADE 2017	17	53	500	1776	1800	1055	2024
Solid	3	India 2018	17	30	500	1776	1800	0	1953
Ring	3	India 2018	17	30	500	1776	1800	1055	1953
Solid	3	Bulgaria 2017	19	30	500	1776	1800	0	1828
Ring	3	Bulgaria 2017	19	30	500	1776	1800	1055	1828

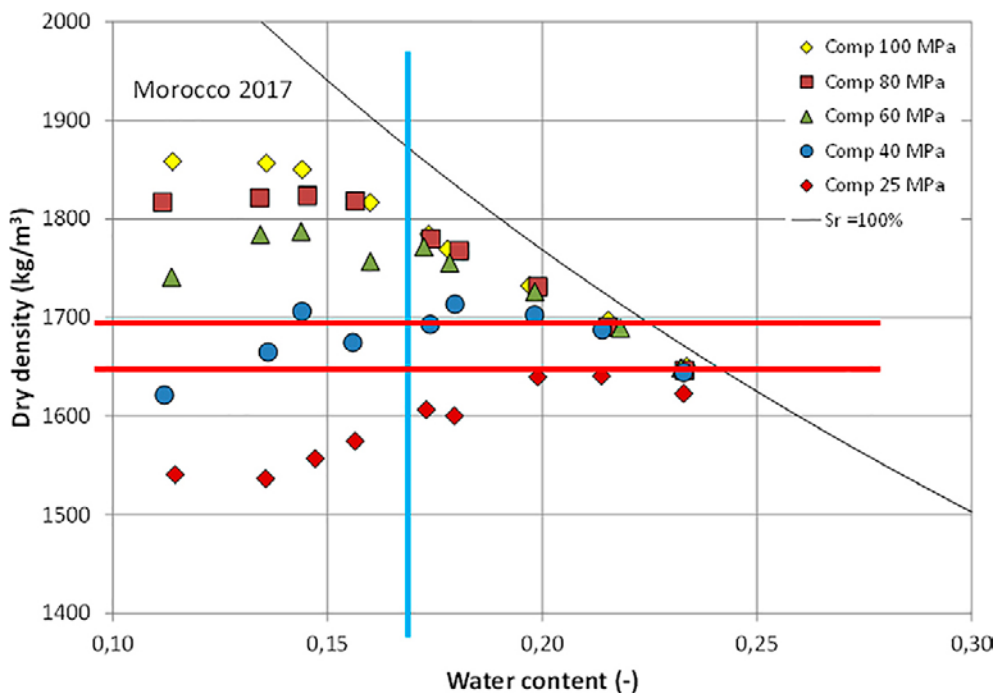

Figure 3-19. Determined dry density as function of both water content and compaction pressure for the Moroccan bentonite. Water content 0.17 and dry densities 1 695 kg/m³ (rings) and 1 650 kg/m³ (blocks) are marked with lines.

The compaction of the bentonite was made with a press which is situated at a workshop owned by the company KELVION AB in the city of Ystad. In total 18 blocks, nine ring-shaped and nine solid blocks were planned to be manufactured.

The current technique for producing buffer blocks is uniaxial compaction of large blocks in a rigid mould. Figure 3-20 illustrates the main steps in the compaction process.

The compaction of the bentonites turned out well except for the Indian bentonite. The reason for the failure with this material was that, it was purchased as a fine powder, which resulted in cracks in the blocks due to entrapped air in the block. After adjustment of the compaction procedure, it was possible to compact acceptable blocks also with this material. It is expected that the issue could be avoided by using a granular size distribution with less fine material.



Figure 3-20. The production of the bentonite blocks.

Although the statistical data is limited, tests made at the same conditions that are with the same material and compaction load ended up with small variation in the average dry density for the blocks i.e. a good repeatability.

Swelling of the blocks after compaction was observed for all blocks. The swelling was in the order of 1-2 mm both in radial and axial direction. This is in accordance with previously made investigations.

Small cracks were observed in most of the compacted blocks. However, the judgement is that the cracks are neither affecting the function of the block nor the possibility to handle the blocks during storage and installation.

After manufacturing some of the blocks were sampled in order to study variations within in dry density and water content (Johannesson et al. 2020). The largest variation in dry density was found for the material Bulgaria 2017, up to 90 kg/m³. The judgement is however that the observed variation in density is not affecting the possibility to use the blocks as buffer as the requirements are set on the average dry density in a deposition hole

All SKBs previous buffer compactations with this technique were done with the bentonite MX-80 but the results from the recent compactations show that it is possible to adapt a design and to compact blocks with different types of bentonites.

3.8 Projects in a monitoring phase

This section describes projects that have been previously installed in the underground laboratory. Most of these are in a monitoring phase, while one project – Long term tests of buffer material, has had retrieval of experiments during 2019. The project Concrete & Clay has retrieval of experiments and analyses in 2017 and 2018. The results from these analyses has been published in 2019, and the results are described in this report.

3.8.1 Prototype Repository

Background

Many aspects of the KBS-3 repository concept have been tested in a number of in situ and laboratory tests. Models have been developed that are able to describe and predict the behaviour of both individual components of the repository, and the entire system. However, processes have not been studied in the complete sequence, as they will occur in connection to repository construction and operation. In addition, it is needed to demonstrate that it is possible to understand the processes that take place in the engineered barriers and the surrounding host rock.

The Prototype Repository provides a demonstration of the integrated function of the repository and provides a full-scale reference for test of predictive models concerning individual components as well as the complete repository system. The Prototype Repository should demonstrate that the important processes that take place in the engineered barriers and the host rock are sufficiently well understood.

The installation of the Prototype Repository has been co-funded by the European Commission with SKB as co-ordinator. The EC-project started in September 2000 and ended in February 2004. The continuing operation of the Prototype Repository is funded by SKB. The retrieval of the outer section, which started in 2011 and was finalized at the end of 2013, was made in cooperation with Posiva. Furthermore, the following organisations were participating and financing the work with the dismantling; NWMO (Canada), ANDRA (France), BMWi (Germany), NDA (United Kingdom), NAGRA (Switzerland) and NUMO (Japan). The reporting of the retrieval of the outer section started during 2013 and was finalized during 2014

Objectives

The main objectives for the Prototype Repository are to:

- Test and demonstrate the integrated function of the final repository components under realistic conditions in full-scale and to compare results with model predictions and assumptions.
- Develop, test and demonstrate appropriate engineering standards and quality assurance methods.
- Simulate appropriate parts of the repository design and construction processes.

Experimental concept

The test is located in the innermost section of the TBM-tunnel at the –450 m level. The layout involves altogether six deposition holes, four in an inner section and two in an outer, see Figure 4-1. Canisters with dimension and weight according to the current plans for the final repository and with heaters to simulate the thermal energy output from the spent nuclear fuel have been positioned in the holes and surrounded by bentonite buffer. The deposition holes are placed with a centre distance of 6 m. This distance was evaluated considering the thermal diffusivity of the rock mass and the maximum acceptable temperature of the buffer. The deposition tunnel is backfilled with a mixture of bentonite and crushed rock (30/70). A massive concrete plug, designed to withstand full water and swelling pressures, separates the test area from the open tunnel system and a second plug separates the two sections. This layout provides two more or less independent test sections.

Instrumentation is used to monitor processes and evolution of properties in canister, buffer, backfill and near-field rock. Examples of processes that are studied include:

- Water uptake in buffer and backfill.
- Temperature distribution (canisters, buffer, backfill and rock).
- Displacement of canister.
- Swelling pressure and displacement in buffer and backfill.
- Stress and displacement in the near-field rock.
- Water pressure build up and pressure distribution in rock.
- Gas pressure in buffer and backfill.
- Chemical processes in rock, buffer and backfill.
- Bacterial growth and migration in buffer and backfill.

The outer test section was retrieved during 2011 after approximately eight years of water uptake of the buffer and backfill.

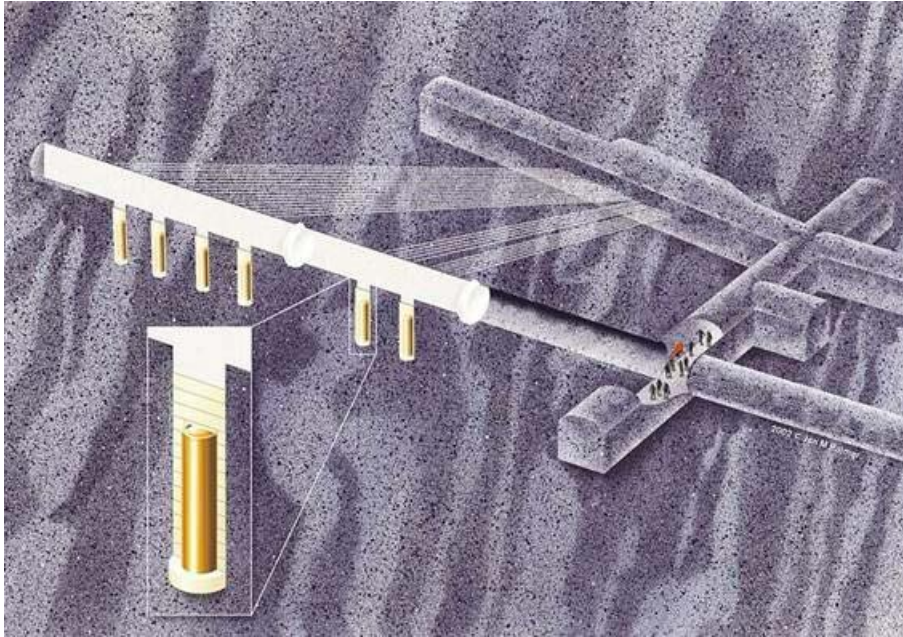

Figure 3-21. Schematic view of the layout of the Prototype Repository (not to scale).

3.8.2 Concrete and Clay

Background

In the present SFR and future repositories for low and intermediate level radioactive waste, SFL and SFR 3, interactions will occur between the barriers (mainly comprising different forms of cementitious materials but also bentonite clay) and the waste. These interactions will affect the barriers chemical, physical and mechanical properties and their ability to prevent the release of radio nuclides.

The project Concrete and Clay was initiated in 2009 with the aim of increasing the level of understanding of processes that may occur in SKB's repositories for low- and intermediate level waste.

Objectives

The objective of this project is to increase the understanding of the processes occurring in repositories for low and intermediate level waste. Three main fields of interest have been identified:

- Decomposition of different waste form materials and transport of the degradation products in a cement based matrix.
- Interface reactions between concrete and different types of bentonite in the presence of degradation products.
- Transport of degradation products in bentonite under natural conditions and mineral alterations in the bentonite.

Experimental concept

The experiments comprise a total of 12 concrete cylinders containing materials representative for low- and intermediate level waste which are deposited in four different installation holes in NASA0507A and NASA2861A in the Äspö Hard Rock Laboratory respectively. Further also a total of 150 bentonite blocks in 5 different packages are deposited in TAS06. In each bentonite block (Ø 270 mm and height 100 mm) 4 different material specimens have been embedded.

As a complement to the large scale experiments, also reference experiments have been prepared. These comprise different types of materials representative of low and intermediate level radioactive wastes which are placed in steel containers filled with a mixture of Äspö ground water and hardened

and crushed cement paste. The objective of these experiments is to serve as a guide for the decision on when to retrieve the large scale experiments.

The experimental concept is further described in Mårtensson (2015).

Experiments are retrieved at regular intervals and the last will be left until the closure of the Äspö HRL.

Results

Retrieval and analysis of experiment #20

During 2017 and 2018 experiment #20 was retrieved and analysed and in 2019 the results were reported (Mårtensson and Kalinowski 2019).

The analyses showed that release and diffusion of different metals and metal chlorides mixed into the cement specimens embedded in the bentonite blocks had been minute for all elements except for Cs for which elevated amounts were found in the bentonite at a distance of up to about 20 mm from the cement specimens, Figure 3-22. For the other elements, the levels were below the methods level of detection or close to the background level in the different bentonites.

The analyses also showed that interfacial reactions involving the parent elements of the cement specimens made of standard cement paste and the different types of bentonite had occurred, Figure 3-23 but also that interactions were considerably more limited when the bentonite had been in contact with specimens made of low-pH cement, Figure 3-24.

Finally, studies of the visual appearance of the bentonite close to the cement/bentonite interface revealed a whitish zone extending up to 3 mm into the bentonite, Figure 3-25. Taken together with other results not reported here, it was concluded that the whitish zone contained $(Ca, Mg)CO_3$. For further details, please refer to Mårtensson and Kalinowski (2019).

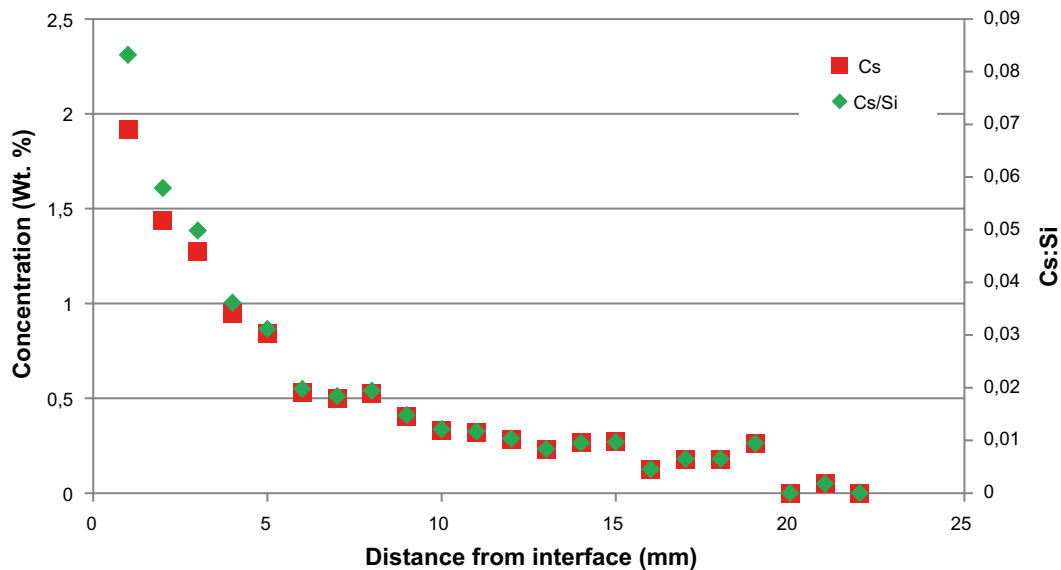

Figure 3-22. Concentration profile of caesium in MX-80 bentonite which had been in contact with a specimen made of standard cement paste containing CsCl.

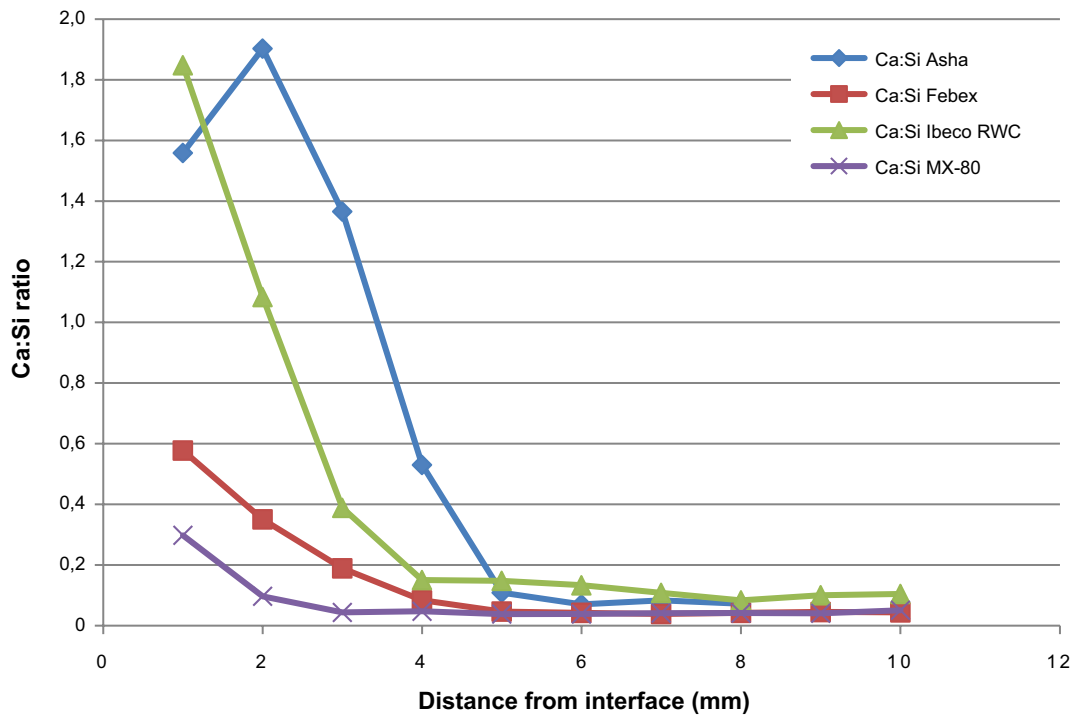

Figure 3-23. Ca: Si ratio in the four different types of bentonite used in this study from the cement-bentonite interface and 10 mm into the bentonite. Here standard cement paste was used.

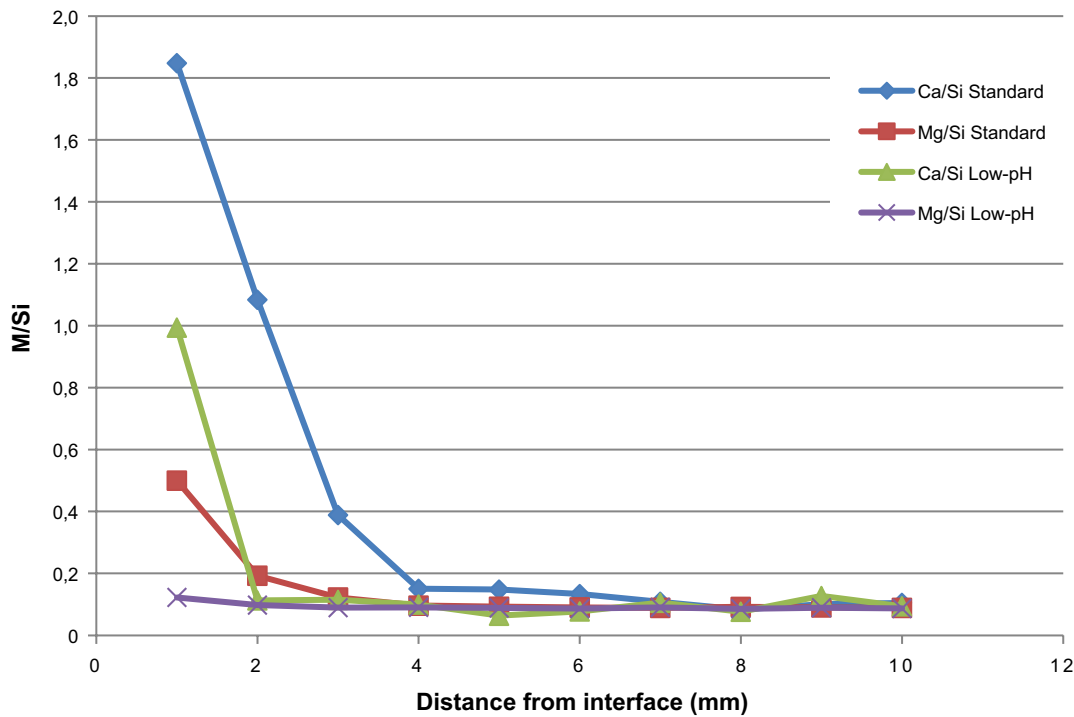

Figure 3-24. Ca: Si and Mg's ratios in the first 10 mm from the cement/bentonite interface for standard cement and low-pH cement in contact with Ibeco RWC bentonite.

Retrieval and analysis of concrete cylinders containing organic material

During 2018 and 2019, 2 concrete cylinders containing different types of organic materials representative of low and intermediate level radioactive waste were retrieved and analysed (Szabó et al. 2020). Previously also the water in the steel containers containing the same type of organic materials had been sampled and analysed for chemical compounds as well as for colloids. The results from the different studies are summarised in the following sections. For details, please refer to Szabó et al. (2020).

Colloid release from organic materials

The amount of colloids found in the steel containers (Figure 3-26) containing different types of organic material was on the same level as in ordinary tap water. The conclusion is therefore that no colloids have been formed through degradation of the organic material within these containers. This is in accordance with current theory that states that the formation of colloids is suppressed in waters of high ionic strength.



Figure 3-25. Image showing the interface zone where MX-80 bentonite had been in contact with a specimen made of standard cement paste.



Figure 3-26. Steel containers placed in the transport box.

NMR study of degradation of organic materials in steel containers

The NMR spectra of samples from steel containers containing cotton, ion exchange resin and filter aid showed signals indicating only minute degradation of the material specimens. In these samples no structural assignments were possible due to low concentration of the compounds formed. The diffusion data, however clearly suggest the formation of a number of different small molecules.

In steel containers containing pieces of rubber gloves (Figure 3-27) several different organic compounds were identified and the same compounds were also found regardless of storage temperature. The NMR spectra from samples from containers stored at different temperatures are practically identical and show signals from the same compounds being identified as plasticisers/ softeners used in the plastic industry. This indicate that the difference in the storage temperature have had no effect on the routes of degradation of the rubber gloves.

Solid state NMR measurements show that the remaining solid rubber polymers are the same in the two containers. The identified compounds are formed by hydrolytic reaction of the dissolved additives of rubber. The identified carboxylic acid derivates (calcium-salt) or alcohols (diols) are in accordance with the structures of well-known plasticisers (or softeners), adipate-, phthalate- and isobutyrate esters used in rubber industry.

Study of specimens from field scale concrete experiments

Among the specimens studied in this work, NMR analyses could only detect organic degradation products in samples from specimens extracted from a concrete core from the part of the concrete cylinder (Figure 3-28) containing pieces of rubber gloves. Studies by means of GC-MS analysis using SPME and UAE confirmed the findings in the NMR studies that the most abundant compounds detected are aliphatic compounds.

For specimens containing other types of organic materials no organic compounds other than those supposedly identified as originating from the cement additives (e.g. grinding aid used during cement production) could be found. The analyses of specimens obtained at different distances from the original position of the pieces of rubber gloves also showed that diffusion of the identified organic materials in concrete has occurred up to a distance of 10 mm from the material specimens.



Figure 3-27. Top view of a container containing pieces of rubber gloves and the rubber pieces taken for solid state NMR measurements.



Figure 3-28. The concrete cylinders have been placed on a pallet for transport.

3.8.3 Alternative Buffer Materials

Background

The Alternative Buffer Materials (ABM) project was started in 2006 with the purpose to evaluate different bentonites as possible buffer candidates, as up this point mainly the Wyoming MX80 bentonite had been in focus.

Objectives

The objectives are to (i) characterise different bentonites regarding composition and properties, (ii) to evaluate their long term performance during realistic conditions, and (iii) to identify and study processes that may occur in the bentonite buffer during special conditions.

Experimental concept

The ABM project consists of a combination of field experiments at the Äspö HRL and laboratory studies of the bentonites performed at a variety of laboratories, including both SKB and external partners.

The field test include more than ten different compacted bentonites, typically heated at 130°, the bentonite block outer diameter is 3 dm, and the central heater has a diameter of 1 dm and the heater material is iron based. The selection of bentonites corresponds to typical commercially relevant bentonite types as well as scientifically more exotic variants.

In recent years the ABM project has been partly overlapping with other SKB projects called the material science projects (KBP 1009, Svensson et al. 2017; KBP1015). In the ABM project the focus is on the scientific difference between the bentonites composition and performance, while in the material science projects the focus is much more on the technical industrialisation process of how to industrialise the analytical and sampling techniques in order to achieve an effective quality control of buffer and backfill bentonites.

Results

In 2006 three experiments were started (ABM 1-3) and in 2012 three additional packages were installed (ABM 4-6). The ABM1 was excavated in 2009 after 2½ years of heating in the rock (e.g. Svensson et al. 2011, Svensson and Hansen 2013), and in 2013 the ABM2 was excavated after 6½ years of heating (e.g. Svensson 2015). The bentonites in ABM1 and ABM2 were typically highly ion exchanged and equilibrated with the Äspö ground water, making the distribution of ions in the different blocks more even, and the salt content typically also increased somewhat. Precipitates (e.g. Ca carbonates /sulphates and NaCl) and iron corrosion products typically formed locally. The integrity of the montmorillonites was typically fairly intact, with only some minor formation of trioctahedral smectite (saponite/ferrosaponite) very close to the corroding iron heater, however, with no expected impact on the buffer performance (Svensson 2015).

Since the start annual ABM meetings has been held for discussing results and collaboration between the many international groups, and every year a number of presentations of the different groups have been held on a selection of international clay conferences, making the ABM experiment a very important and central experiment for bentonite long term performance studies, as well as Round Robin tournaments with the purpose of investigating and increasing the performance of selected laboratory analytical techniques.

In 2017 the ABM5 was excavated. The ABM5 experiment was different from the others, as it was water saturated at a lower temperature of 80°, and during its final year it was heat shocked at 150-200° in order to study effects from temperatures much higher than the expected boiling point (as a higher design temperature of the buffer would be economically very beneficial if possible). The ABM5 bentonite blocks were upon excavation highly fractured due to the very high temperature (Figure 3-29), detailed analysis of the blocks are to be performed in the coming years.



Figure 3-29. Highly fractured bentonite blocks from the very high temperature experiment ABM5 excavated in 2017.

3.8.4 KBS-3 Method with Horizontal Placement

Background

The KBS-3 method is based on the multi-barrier principle and constitutes the basis for planning the final disposal of spent nuclear fuel in Sweden. The possibility to modify the reference design, which involves vertical emplacement of singular canisters in separate deposition holes (KBS-3V), to consider serial disposal of several canisters in long horizontal drifts (KBS-3H) has been considered since the early 1990s, see Figure 3-30.

In 2001 SKB published a RD&D programme (SKB 2001) for the KBS-3H variant with four phases. The current joint (SKB/Posiva) project phase, KBS-3H System Design, was initiated in 2011 and it will be concluded end 2016. All development steps have been made in close cooperation between SKB and Posiva. The current project phase covers all areas of the KBS-3 method but the focus is on the KBS-3H specific issues.

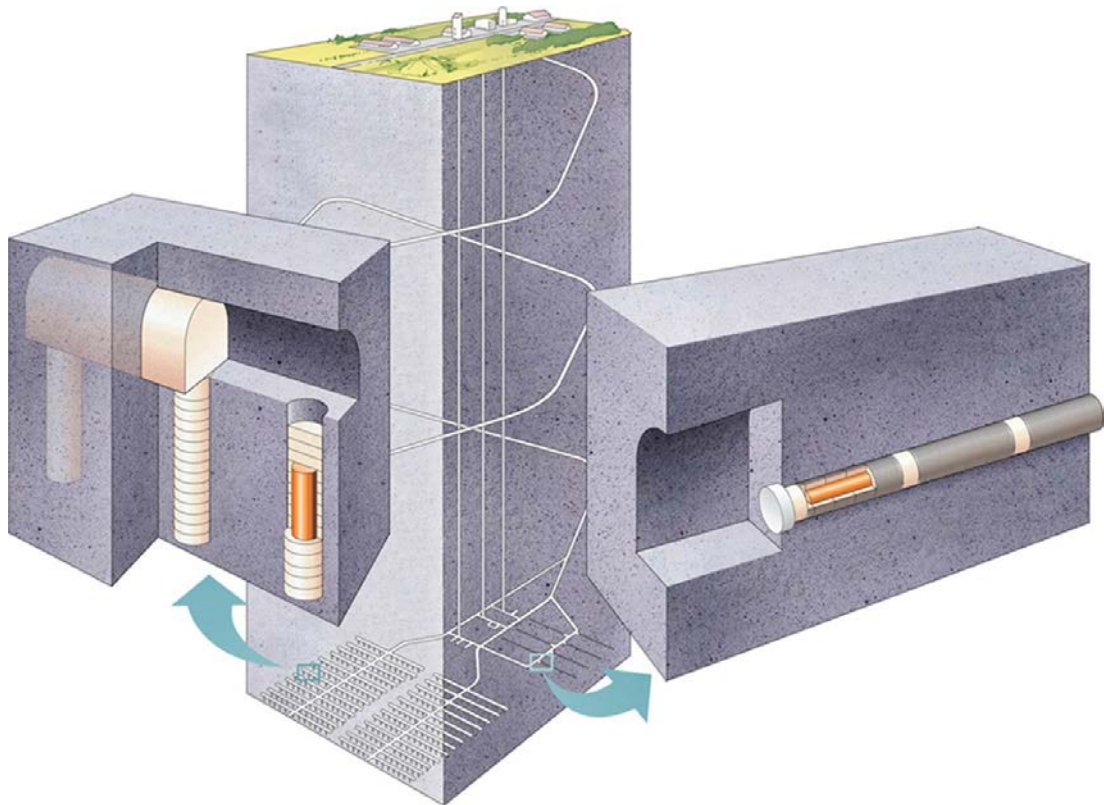

Figure 3-30. Schematic drawing of the KBS-3V reference design (left) and KBS-3H (right).

Objectives

The final goal of the KBS-3H System Design phase is to bring KBS-3H design and system understanding to such a level that a PSAR can be prepared and that a subsequent comparison between KBS-3V and KBS-3H is made possible. For components and sub-systems this will be achieved by assessing the design premises/basis, updating the requirements, verifying that the design solution meets and can be manufactured according to the requirements and based on this, reaching the system design level in accordance with SKB's model of delivery. The system design level also includes devising plans for industrialisation/implementation including control programs and risk assessments.

Vital in reaching the project's main objective is to produce the basis and carry out long-term safety evaluation. The safety evaluation will be done for Olkiluoto site only. The work for Olkiluoto is deemed to provide results that will indicate if KBS-3H is also applicable to Forsmark site. This work will be based on earlier safety assessment work and will make use of Posiva's safety case "TURVA-2012" for KBS-3V (produced by SAFCA) for Olkiluoto and SR-Site for Forsmark. This is expected to be achieved by the end of 2016.

Experimental concept

The DAWE (Drainage, Artificial Watering and air Evacuation) design alternative has been chosen as the reference design for the KBS-3H concept. Consequently, the deposition drift is divided into two compartments with an approximate length of 150 m each.

In the KBS-3H concept, the canisters are placed in long horizontal deposition drifts, see Figure 3-31. Unlike the KBS-3V concept (reference design), the KBS-3H concept utilises a prefabricated installation package called Supercontainer that is assembled in an industrial process at the canister reloading station before disposal, thus reducing the possibility of human error. The Supercontainer consists of a perforated protective shell made of metal with bentonite buffer and copper canister installed inside the buffer. Several Supercontainers are installed into each deposition drift. The drifts are almost horizontal, and their maximum length is 300 metres. The drifts have a diameter of c. 1 850 mm, and they have a slight upward inclination (c. 2°), which is why water is removed from the drifts by gravity along the bottom of the deposition drift during installation. The Supercontainers and the bentonite blocks installed in the drift stand on parking feet between which the inflow water can flow out of the drift. The gap between the Supercontainer and the drift wall is 44.5–48 mm.

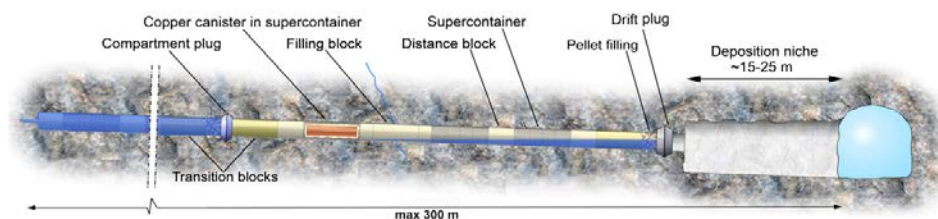

Figure 3-31. KBS-3H reference design DAWE with its main components; the plugs with their transition zones, the Supercontainers, and the distance and filling blocks. The illustration shows an ongoing artificial water filling procedure of the second compartment.

Differences between KBS-3V and KBS-3H

The main differences between the two concepts: the horizontal and the vertical emplacement can be divided in the following aspects when comparing the two options from the angle of KBS-3H:

- Cost aspect
 - Less costly mainly due to lower volumes of excavation and backfilling
- Environmental aspect
 - Less excavation (no deposition tunnels)
 - The volume to be backfilled much smaller
 - Smaller clay production facility needed
- Operational safety
 - No risk of canister falling during installation
 - Risk of fire is smaller due to less amount of vehicles and machines which form the most significant fire load
- Occupational safety
 - Less traffic in the repository
 - The number of work phases smaller
 - Less tunnel reinforcement needed during installation phase (reinforcement structures need to be dismantled before deposition)
 - Less explosives will be stored underground since mechanical excavation used for drifts
 - Less risks for being exposed to radiation
- Long-term safety
 - The most important of all aspects
 - Currently disadvantageous for 3H due to the issue of chemical erosion entailing the so-called “domino effect”
 - The definition of initial state better due to artificial wetting

3.8.5 Large Scale Gas Injection Test

Background

The large-scale gas injection test (Lasgit) is a full-scale *in situ* test designed to answer specific questions regarding the movement of gas through bentonite in a mock deposition hole located at 420m depth in the Äspö Hard Rock Laboratory (HRL).

The multiple barrier concept is the cornerstone of all proposed schemes for the underground disposal of radioactive wastes. Based on the principle that uncertainties in performance can be minimised by conservatism in design, the concept invokes a series of barriers, both engineered and natural, between the waste and the surface environment. Each successive barrier represents an additional impediment to the movement of radionuclides. In the KBS-3 concept, the bentonite buffer serves as a diffusion barrier between the canister and the groundwater in the rock. An important performance requirement of the buffer material is that it should not cause any harm to the other barrier components. Gas build-up from, for example, corrosion of the iron insert, could potentially affect the buffer performance in three ways:

- Permanent pathways in the buffer could form at gas breakthrough. This could potentially lead to a loss of the diffusion barrier.
- If gas cannot escape through the buffer, the increase in pressure could lead to mechanical damage of other barrier components.
- The gas could de-hydrate the buffer.

Knowledge pertaining to the movement of gas in initially water saturated buffer bentonite is largely based on small-scale laboratory studies. While significant improvements in our understanding of the gas-buffer system have taken place, laboratory work highlighted a number of uncertainties, notably the sensitivity of the gas migration process to experimental boundary conditions and possible scale dependency of the measured responses. These issues are best addressed by undertaking large scale

gas injection tests. Additionally, a full-scale experiment designed to identify gas pathway formation is suited to study the hydration of the bentonite buffer over a 10+ year time-scale.

The experiment has been in continuous operation since February 2005. The first two years (Stage 1, up to day 843) focused on the artificial hydration of the bentonite buffer. This was followed by a year-long programme of hydraulic and gas injection testing in filter FL903 (Stage 2, day 843 to 1 110). A further year of artificial hydration occurred (Stage 3, day 1 110 to 1 385), followed by a more complex programme of gas injection testing in filter FL903 (Stage 4, day 1 430-2 064). In late 2010 attention moved from the lower array filter (FL903) to the upper array (FU910). Stage 5 started on day 2 073 and was completed on day 2 725. Focus then returned to the lower array (FL903) in late 2012 and involved a gas injection test throughout 2013. In 2014, the focus of the experiment was to determine the hydraulic properties of the bentonite buffer at all measurable locations by means of two-stage hydraulic head tests. In 2015, the experiment returned to a period of prolonged natural and artificial hydration.

Objectives

The aim of Lasgit is to perform a series of gas injection tests in a full-scale KBS-3 deposition hole. The objective of this experimental programme is to provide data to improve process understanding and test/validate modelling approaches which might be used in performance assessment. Specific objectives are:

- Perform and interpret a series of large-scale gas injection test based on the KBS-3 repository design concept.
- Examine issues relating to up-scaling and its effect on gas movement and buffer performance.
- Provide additional information on the processes governing gas migration.
- Provide high-quality test data to test/validate modelling approaches.
- Provide data on the hydration of a full-scale KBS-3 system.

Experimental concept

Lasgit is a full-scale demonstration project conducted in the assembly hall area in Äspö HRL at a depth of -420 m (Figure 3-32). A deposition hole, 8.5m deep and 1.8m in diameter, was drilled into the gallery floor. A full-scale KBS-3 canister (without heater) has been emplaced in the hole. Thirteen circular filters of varying dimensions are located on the surface of the canister to provide point sources for the injection of gas to mimic canister defects. Pre-compacted bentonite blocks with high initial water saturation have been installed in the deposition hole. The hole has been capped by a conical concrete plug retained by a reinforced steel lid capable of withstanding over 5 000 tonnes of force.

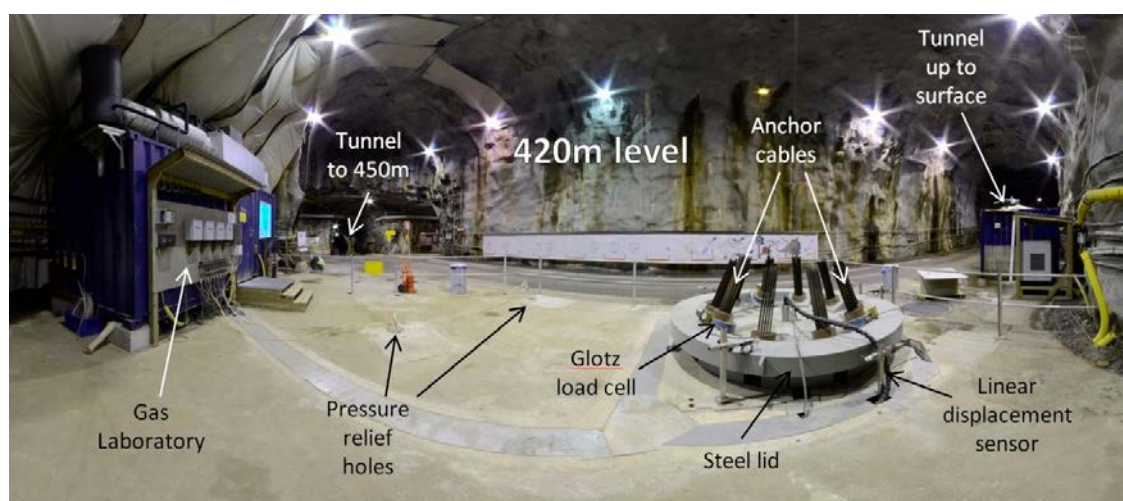

Figure 3-32. The Large scale gas injection test at the -420 m level in Äspö HRL.

In the field laboratory instruments continually monitor variations in the total stress and porewater pressure at the borehole wall, the temperature, any upward displacement of the lid and the restraining forces on the rock anchors. The experiment is a “mock-up test” which does not use any radioactive materials.

Lasgit has consisted of four operational phases; the installation phase, the hydration phase, the gas injection phase, the homogenisation phase. The installation phase was undertaken from 2003 to early 2005 and consisted of the design, construction and emplacement of the infrastructure necessary to perform the Lasgit experiment.

The hydration phase began on the 1st February 2005 with the closure of the deposition hole. The aim of this phase of the experiment was to fully saturate and equilibrate the buffer with natural groundwater and injected water. The saturation and equilibration of the bentonite was monitored by measuring pore pressure, total pressure and suction at both the buffer/rock interface and key locations within individual clay blocks. The hydration phase provided an additional set of data for (T)HM modelling of water uptake in a bentonite buffer.

The test will be dismantled during 2020.

3.8.6 In Situ Corrosion Testing of Miniature Canisters

Background

The post-failure evolution of the environment inside a copper canister with a cast iron insert is important for the assessment of the release of radionuclides from the canister in a failure scenario. After failure of the outer copper shell, the course of the corrosion in the gap between the copper shell and the cast iron insert will determine the subsequent release of radionuclides. A possible scenario is that the formation of solid iron corrosion products could exert an internal load on the copper shell, which could lead to deformation. This process has been studied earlier both in laboratory experiments (Bond et al. 1997) and by modelling (Smart et al. 2006).

In the MiniCan *In Situ* test, five miniature copper-cast iron canisters have been exposed to the groundwater flow in boreholes in the Äspö HRL since late 2006. In order to model failure and allow corrosion of the iron insert, millimetre defects were introduced into the outer copper shell. Corrosion will take place under saline, eventually oxygen-free and reducing conditions in the presence of the microbial flora in the Äspö groundwater; such conditions are very difficult to create and maintain for longer periods of time in the laboratory. Consequently, the MiniCan experiment will be valuable for understanding the microbiological influences on canister corrosion and degradation, as well as for the understanding the development of the environment inside the canister after penetration of the outer copper shell.

Objectives

The main objectives of the experiment are to provide information about; 1) how the environment inside a copper-cast iron canister would evolve if failure of the outer copper shell was to occur, and 2) how microbiological activity affects canister corrosion. The results of the experiment will be used to support process description in the safety assessment.

The following specific issues are being addressed:

- Does water penetrate through a small defect into the annulus between the cast iron insert and the outer copper canister?
- How does corrosion products spread around the annulus in relation to the leak point?
- Does the formation of anaerobic corrosion product in a constricted annulus cause any expansive damage to the copper canister?
- Is there any detectable corrosion at the copper welds?
- Are there any deleterious galvanic interactions between copper and cast iron?
- Does corrosion lead to failure of the lid on the iron insert?

- What are the corrosion rates of cast iron and copper in the repository environment?
- What is the risk of stress corrosion cracking of the copper?
- How does the microbial flora of the deep ground water influence the development of canister corrosion?

Experimental layout

In late 2006, five experimental packages containing miniature copper-cast iron canisters were mounted at a depth of 450 m in the Äspö HRL (Smart and Rance 2009). The model canister design simulates the main features of the SKB reference canister design. The cast iron insert contains four holes simulating the fuel assembly channels, together with a bolted cast iron lid sealed with a Viton O-ring. The copper lid and base is electron beam welded to the cylindrical body. The annulus between the cast iron insert and the outer copper body is < 30 µm wide. All the canisters have one or more 1 mm diameter defects in the outer copper shell.

The canisters are mounted in electrically insulated support cages (Figure 3-33), which contain bentonite clay of two different densities. There is no direct electrical contact between the copper canister and the stainless steel support cages. One miniature canister does not have any bentonite, to investigate the effect of direct groundwater flow on the corrosion behaviour.

Cast iron and copper corrosion coupons are mounted inside the support cages of each experimental package and corrosion behaviour is monitored electrochemically. Cast iron and copper weight loss specimens are also present. Each support cage contains a 'sandwich type' copper-cast iron specimen to investigate oxide jacking effects and galvanic corrosion. U-bend and wedge open loading stress corrosion specimens are mounted in one of the boreholes in direct contact with the groundwater, to assess the possible risk of stress corrosion cracking of copper. In addition, two of the canisters will be monitored using strain gauges to detect any expansion in the copper shell. The redox potential, E_h , is being monitored using a combination of metal oxide, platinum and gold electrodes.

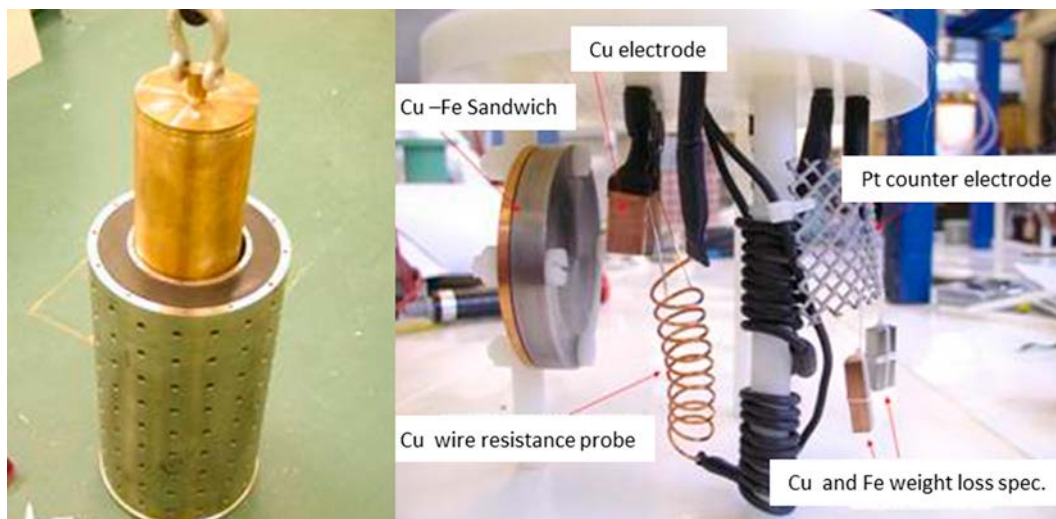

Figure 3-33. Model canister being lowered into support cage containing bentonite pellets in annulus (left). Test electrodes inside support cage around model canister experiments (right).

The boreholes are located in a region with many fractures, leading to a plentiful supply of groundwater to the canisters. The experiments are continuously monitored to measure the following parameters:

- Corrosion potential of the model canister, cast iron and copper.
- Electrochemical potential of gold, platinum and a mixed metal oxide Eh probe.
- Corrosion rate of cast iron and copper, using linear polarisation resistance (LPR), AC impedance (ACI), electrochemical noise (ECN), and the electric resistance in a copper wire.
- Strain on the surface of two of the model canisters.
- Hydrostatic pressure in the boreholes.

Water samples are taken regularly from the support cages as well as from the boreholes to monitor the development of the local water chemistry. The experiments will remain *in situ* for several years, after which they will be retrieved, dismantled and the evolution of the corrosion front inside the canister will be analysed. Further details on experimental concept are presented in Smart and Rance (2009).

3.8.7 Long term tests of buffer material

Background

Comprehensive research and development work have been carried out during the last thirty years in order to determine the basic behaviour of unaltered bentonite material. The results have been reported in technical reports, scientific articles, and models concerning both unsaturated and saturated buffer conditions. The models are believed to well describe the function of an unaltered MX-80 bentonite buffer after water saturation with respect to physical properties, e.g. swelling pressure, hydraulic conductivity and rheological behaviour.

In a HLW repository, there will be a temperature increase and a thermal gradient over the bentonite buffer as a result of the decaying spent fuel. Original water in the bentonite will thereby be redistributed parallel to an uptake of water from the surrounding rock. The Long Term Test of Buffer Material (LOT) project aims at studying possible alteration of the bentonite as a result of the hydro-thermal evolution, both with respect to mineralogy and to sealing properties.

Objectives

The general objectives in the LOT test series may be summarized in the following items:

- Collect data for validation of models concerning buffer performance under quasi-steady state conditions after water saturation, e.g. swelling pressure, hydraulic conductivity and rheological properties.
- Check of existing models concerning buffer degrading processes, e.g. mineral redistribution and montmorillonite alteration.
- Check of existing models concerning cation diffusion in bentonite.
- Check of calculated data concerning copper corrosion, and collect information regarding the character of possible corrosion products.
- Collect information, which may facilitate the realization of the full-scale test series, e.g. the Prototype project, with respect to preparation, instrumentation, retrieval, subsequent analyses, evaluation and data handling.

Experimental concept

The LOT test series can be described as a multi-task experiment in which relatively small test parcels are exposed to field conditions at Äspö Hard Rock Laboratory (HRL). The experiment includes a total of seven test parcels, Table 3-6. Each test parcel consists of a central copper tube with an electrical heater inside. Prefabricated ring-shaped bentonite blocks are placed around the copper tube. The test parcels were placed in a vertically drilled 4-meter deep borehole in granitic rock, 450 meters below ground surface at Äspö HRL.

Different types of instruments were placed in the bentonite measuring, total pressure, pore pressure, relative humidity and temperature.

Several test parcels, also contained equipment used for special measurements: ⁶⁰Co tracer doped plugs placed in one block to study radionuclide migration in compacted bentonite, copper coupons which can be used to quantify total corrosion with accurate methods (i.e. gravimetric analysis), which is not possible for the large copper tube (see further Johansson et al. 2020).

After exposure to field conditions for a defined period, a test parcel is extracted by overlapping drilling outside the original borehole, and the whole test parcel is lifted and transported to a laboratory where it is divided. Material from defined positions in the parcel and reference material are thereafter examined by well-defined tests and analyses in order to provide data for the different objectives.

The dimensions of the test parcels were kept considerably smaller, especially the diameter, compared to a KBS-3 deposition hole in order to:

- shorten the water saturation period and thereby have saturated condition during a substantial part of the test period
- achieve a higher temperature gradient over the buffer material
- facilitate sampling, i.e. release and lift the exposed test parcel in one piece

Table 3-6. Test program for the LOT project.

Type	No.	max T (°C)	Controlled parameter	Time (years)	Remark
A	1	130	T, [K*], pH, am	1	Reported, TR-00-22
A	0	120-150	T, [K*], pH, am	1	Reported, TR-09-31
A	2	120-150	T, [K*], pH, am	6	Reported, TR-09-29
A	3	120-150	T	20	Dismantled 2019
S	1	90	T	1	Reported, TR-00-22
S	2	90	T	20	Dismantled 2019
S	3	90	T	>20	Ongoing

A= adverse conditions, S= standard conditions, T= temperature, [K*]= potassium concentration, pH= high pH from cement, am= accessory minerals added.

Results

Two test parcels, S2 with standard conditions, Figure 3-34, and A3 with adverse conditions, Figure 3-35, have been dismantled during 2019, and analyses are ongoing.

This result section is to a large extent an excerpt from the public report *Installation, monitoring, dismantling and initial analyzes of material from LOT test parcel S2 and A3* (Sandén and Nilsson 2020), where further details are described.

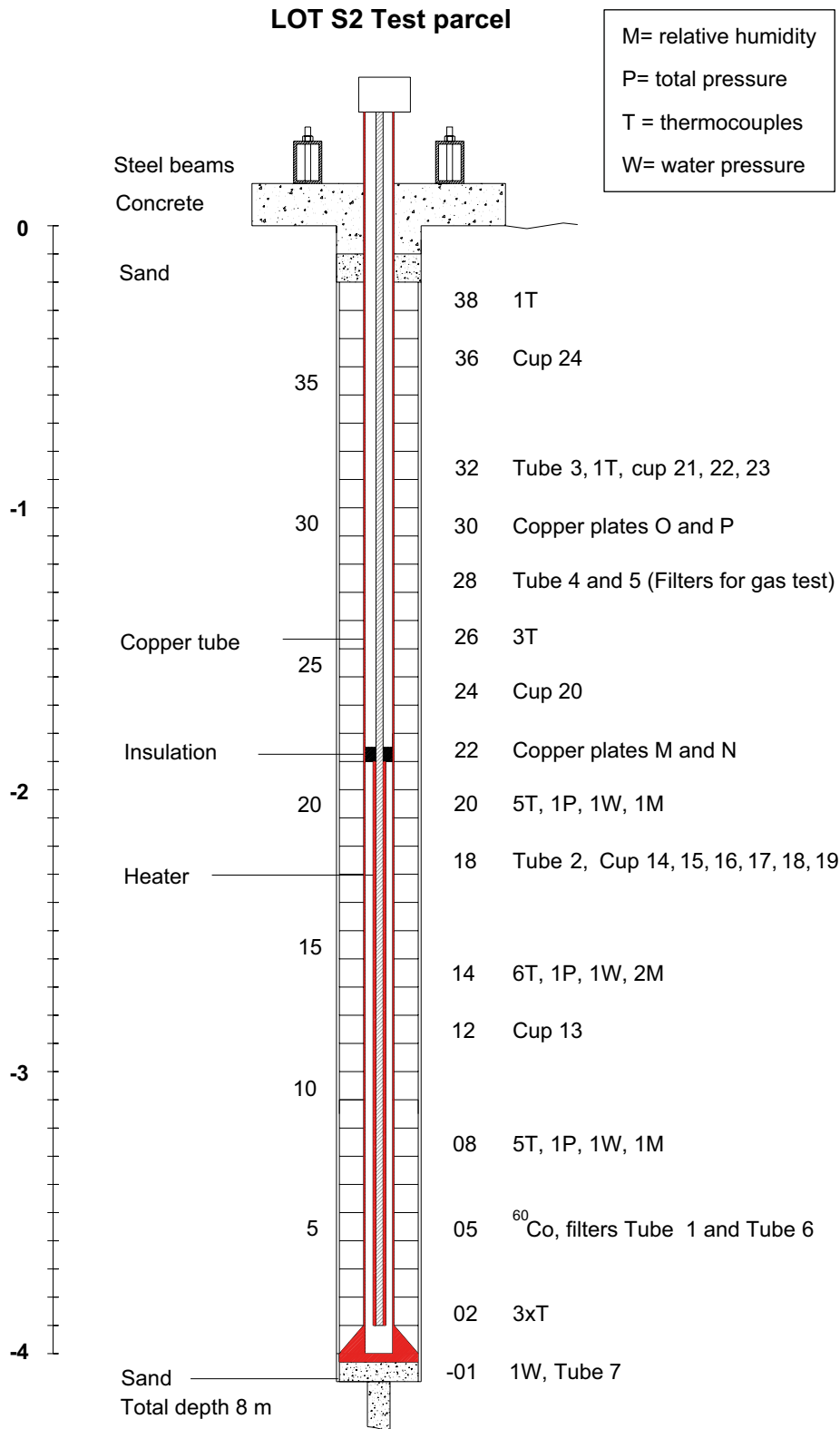

Figure 3-34. Schematic drawing showing the principal design of Test parcel S2. The type of instruments in the different blocks is described to the right. The block numbers (counted from bottom) are given together with the depth of the test hole.

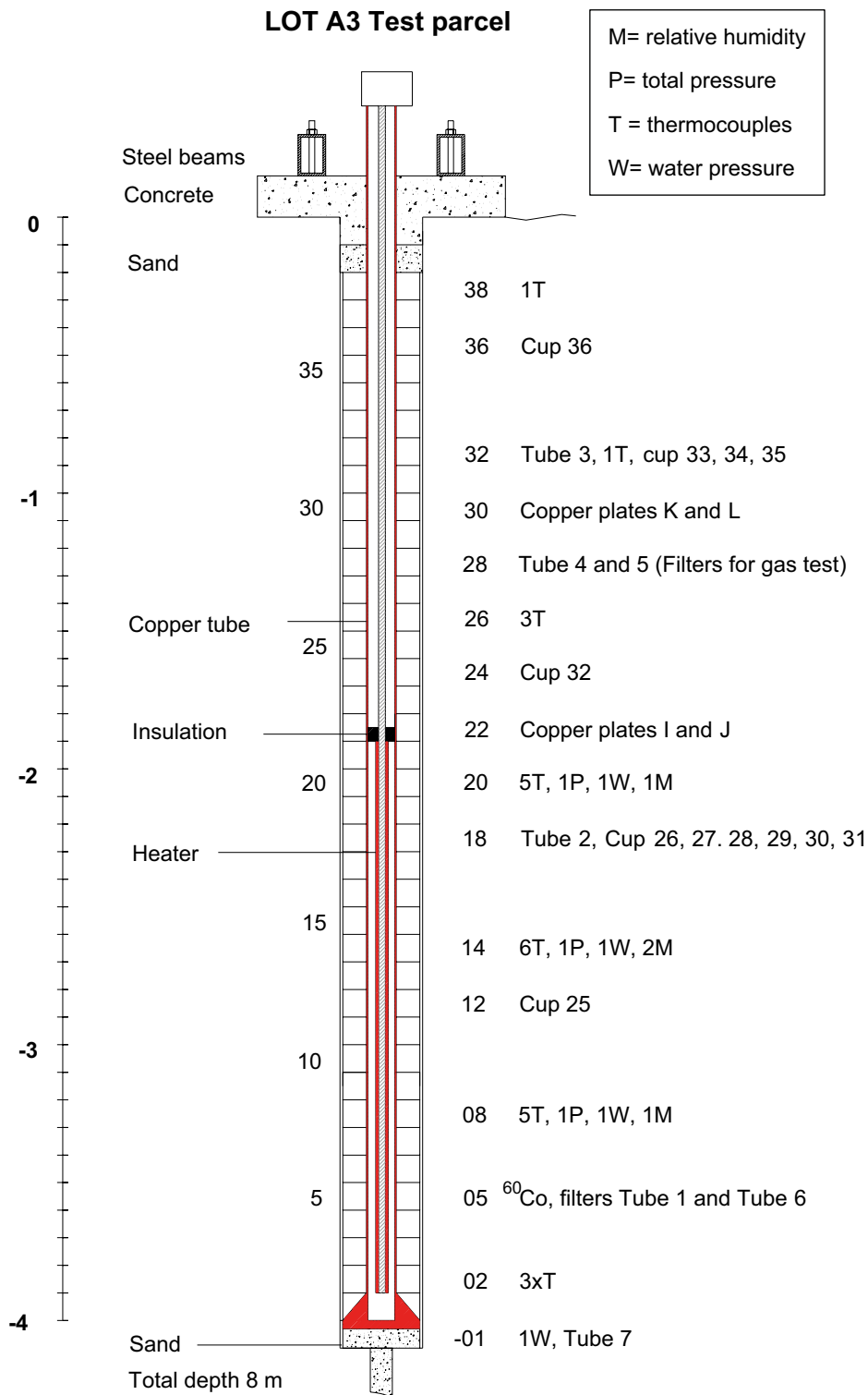

Figure 3-35. Schematic drawing showing the principal design of Test parcel A3. The type of instruments in the different blocks is described to the right. The block numbers (counted from bottom) are given together with the depth of the test hole.

Bentonite

Wyoming bentonite with the commercial name MX-80 was the source material for all bentonite components in the system. The blocks were manufactured to achieve 2 000 kg/m³ when saturated.

Heating

The power regulating system worked very well during the entire twenty years test duration and an example from block 14 in test parcel S2 is illustrated in Figure 3-36. The full temperature data as well as other sensor data is reported in Sandén and Nilsson (2020). In September 2014, the system was updated with new components and this resulted in a small drop in the registered temperature for both test parcels. The drop is clearer for test parcel S2.

No overheating or major temperature drops took place during the test time.

Dismantling

The test parcels were released by overlapping percussion drilling in the surrounding rock. The diameter of the boreholes was 89 mm diameter and the depth around 4.5 m. Larger, 280 mm, core drilled holes was drilled to allow for wire sawing of the bottom of the rock column.

In conjunction with the drilling of the surrounding slot, large efforts were made to ensure that no water, either natural from the rock or cooling water from the drilling machines, could reach the bentonite parcel via e.g. fractures in the rock, since this may influence the bentonite that could swell and make the surrounding rock cover crack. Pumps were used continuously to keep the water level in the boreholes surrounding the test parcels at a low level. In addition, alarms were installed to monitor the water level also during non-working hours.

The released test parcel including rock-cover was lifted by a crane lorry and transported to the ground surface and then further to the laboratory at Äspö, Figure 3-37. The total weight of the rock/bentonite parcel was about 4 500 kg, and the diameter was 650 to 700 mm. i.e. the rock cover of the test parcel was 150 to 200 mm.

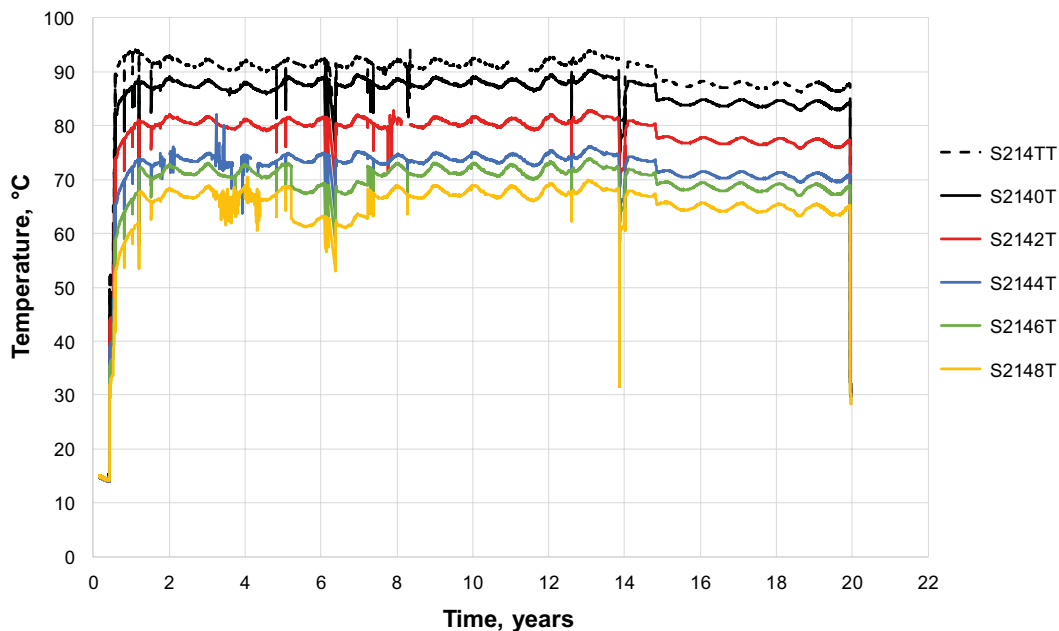

Figure 3-36. Registered temperature plotted versus time for six sensors positioned in test parcel S2, block 14.



Figure 3-37. The entire test parcels, including rock-cover, were being placed on a lorry for transport to the ground surface.

The covering rock was successively removed from the test parcels. Naturally occurring fractures and weaknesses in the rock were used together with drilling and wedges to loosen rock pieces from the test parcels. Figure 3-38 shows the exposed bentonite. The approximate position of the original block interfaces was identified in the exposed bentonite by measuring the distance from the bottom plate but also by use of different tubes going in to defined positions. The north direction of the test parcel was checked and marked on the bentonite. The bentonite blocks were cut by using a saber saw, Figure 3-39. To facilitate removal of the blocks from the central copper tube it was often necessary to also do a cut in the blocks along the test parcel. The removed blocks, often two or three together, were marked and temporarily placed in plastic bags to minimize the risk of drying.



Figure 3-38. Large pieces of rock were removed from the test parcels and the bentonite exposed to allow for sampling.



Figure 3-39. A saber saw was used to cut of blocks from the test parcel. The cuts were made approximately at the original block interfaces. The lines along the parcel that can be seen on the bentonite surface originate from thermocouples and other tubes that had been placed on the test parcel periphery (photo from test parcel A3).

Sampling

The water content and density were determined on several positions in the two test parcels. Two slices were cut out from each bentonite block, Figure 3-40. From one of the slices, samples were taken at the mid-height of the blocks at five different radial distances from the heater. The measurements were made on every block except no. 4, 5 and 6 (in block no. 5 there was ^{60}Co -tracer doped plugs and this block together with the neighboring were sent for special analyzes). In total 180 samples were analyzed from each test parcel.

The second slice was saved for future sampling and more detailed analyses.

The copper coupons which were emplaced in bentonite block no. 22 and 30 in both of the current test parcels were carefully located using a metal detector. All copper coupons, four in each test parcel, were found undamaged. The work and results from the investigations on the coupons are ongoing and will be reported in Johansson et al. (2020).

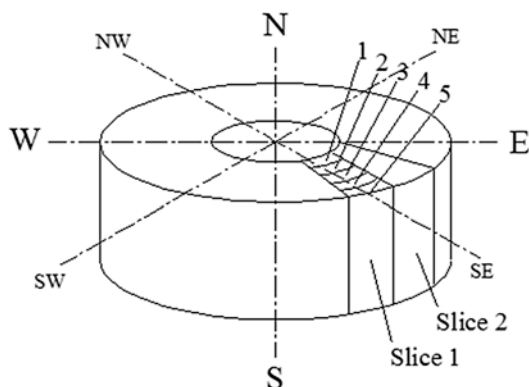

Figure 3-40. Two slices were cut from each bentonite block. One slice was used for the initial determination of water content and density and the other slice was saved for future sampling and detailed analyses.

Initial analyses

Basic properties of the bentonite test material were measured in many positions in the two test parcels to achieve a picture of the water content and density distribution. This data was then used to calculate the degree of saturation.

Compiled results from the initial analyzes on the bentonite from the two test parcels are presented in Figure 3-41(water content), Figure 3-42 (dry density) and Figure 3-43 (degree of saturation).

The results show that both test parcels had a similar water content and density distribution. The water content varied between 27 and 42 %.

The density was significantly lower in the bottom part and at the top of both parcels, mainly below 1 450 kg/m³, while the density in the hottest part was rather high, typically between 1 500 and 1 550 kg/m³, Figure 3-42. There are two explanations for the rather large differences in density and water content along the test parcels.

Lower part of the test parcels.

The test parcels were installed resting on a sand filling placed in the bottom of the borehole. This sand filling was placed both to fill up the smaller pilot hole but also to provide a stable ground for the test parcels. The sand filling was also later used during the water filling in conjunction with the test start. A titanium tube with a filter tip was then placed in the sand filling and water was injected so that the initial gaps between blocks and rock surface were filled with water from the bottom of the test holes. The sand has thus served as a filter, where inflowing water to the pilot hole has been distributed upwards through the annular gap around the bottom plate and further up to the bentonite. It is likely that this access to water from the bottom has led to an early swelling of the lower part of the test parcel.

The upper part of the test parcels.

In each of the test parcels, a sand filling with a thickness of about 100 mm was positioned between the uppermost bentonite blocks and the concrete top plugs. This has probably resulted in that the blocks at the top has swelled and compacted the sand filling upwards.

These early swelling at the bottom and at the top has resulted in density gradients in the bentonite that were still present also after twenty years test duration.

There is also, for both test parcels, a strong radial density gradient. All bentonite blocks have swelled in radial direction and after twenty years test duration there are still a clear difference in density between the inner parts at the central copper tube and the outermost parts close to the rock. There is a homogenization process ongoing in the bentonite. However, differences in density are expected also after long time when homogenization has occurred, depending on inner friction in the bentonite.

The degree of saturation was close to 100 % in most positions in both test parcels, Figure 3-43. In test parcel A3, the right graph, there was a small difference in degree of saturation in the hottest part i.e. between 500 and 2 000 mm from the bottom compared to the parts with lower temperature. In the hottest part, the degree of saturation was somewhat lower, roughly between 94 and 97 % compared to between 97 and 100 % in the parts with lower temperature. The difference is thus rather small but still clear. The difference depends probably on the thermal expansion of water during the heating phase. When the power was turned off and the temperature decreased, the water took up less space which means that additional water was needed to again reach full saturation. Since the time from turning off the power to the lift of the test parcel was rather short, there was not enough time to restore the saturation.

Overall, the evolution of the tests based on the initial analyses has been generally as expected.

The bentonite is fully saturated, but the homogenisation process is still ongoing. The average dry density is within the expected range, although the upper- and lowermost parts have been affected by the experimental setup and show somewhat lower dry densities.

The applied power to the electrical heaters was approximately 500 W for test parcel S2 and 800 W for test parcel A3. This corresponded with the scoping calculations made before starting the pilot tests.

Continued, and more detailed analyses of the bentonite from both parcels will be carried out and reported in the coming years, for example: XRD, XRF, CEC, EC, SEM/EDS, μ -RAMAN, LECO, ICP-AES, IR, swelling pressure, hydraulic conductivity, shear strength, Co-60 and Mössbauer analysis.

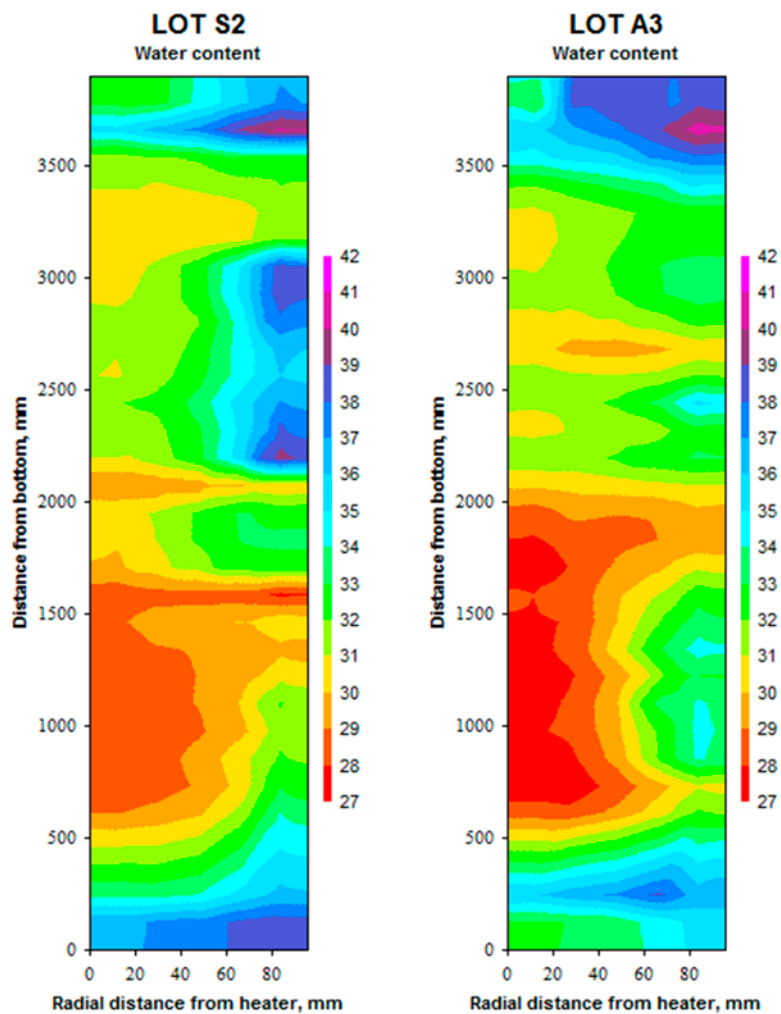

Figure 3-41. Water content distribution for test parcel S2 (left) and test parcel A3 (right).

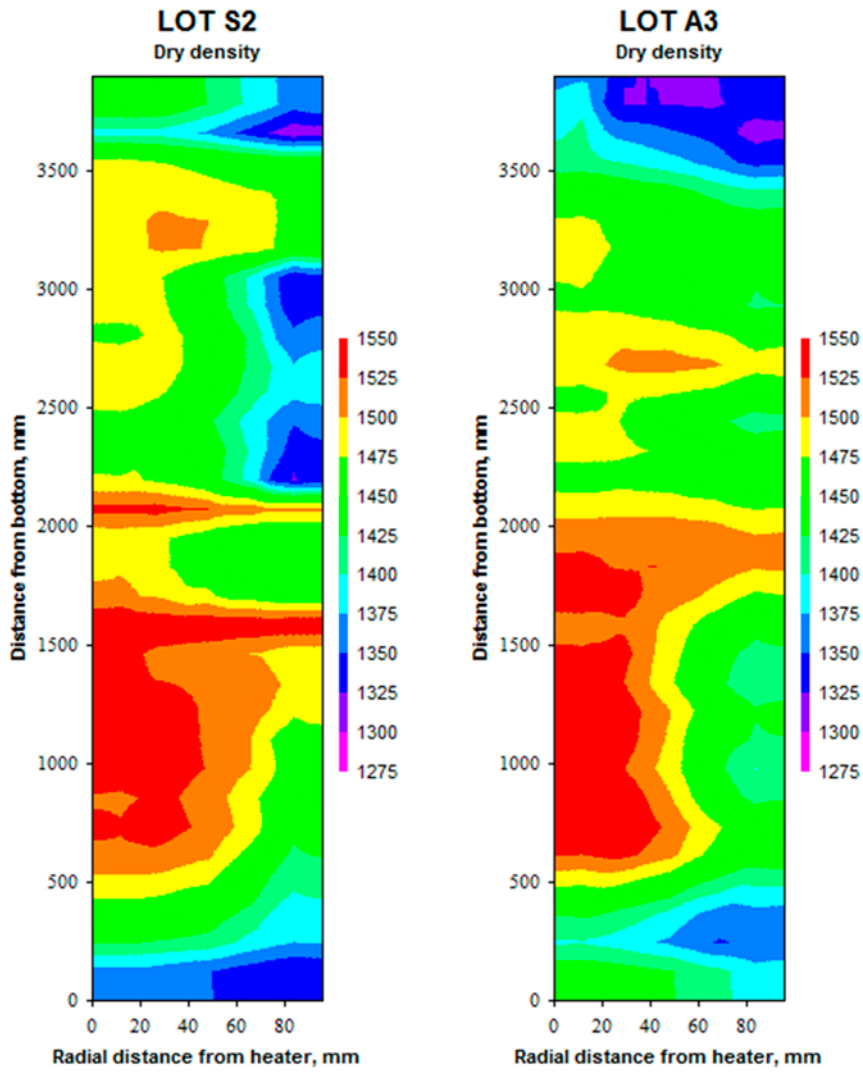

Figure 3-42. Dry density distribution for test parcel S2 (left) and test parcel A3 (right).

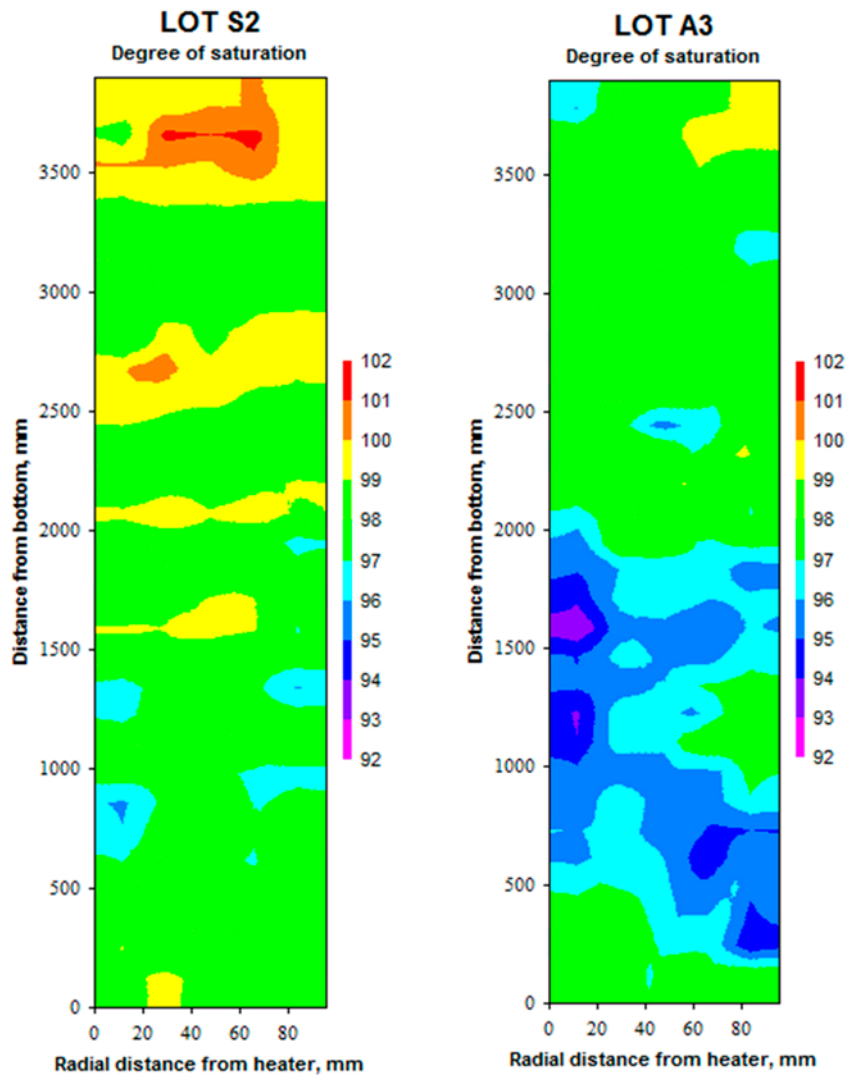

Figure 3-43. Degree of saturation for test parcel S2 (left) and test parcel A3 (right).

4 Mechanical- and system engineering

4.1 General

At SKB, techniques for the final disposal of spent nuclear fuel are under development. A total of over 200 different products and components known today are to be developed for the Spent Fuel Repository. Both well established existing technologies and new technologies will be used. As far as possible standard equipment, modified and adapted to the activity, will be used. Where no standard equipment is available new objects must be developed.

Assessment has been made of when the production of machines must begin and when they need to be completed, as well as whether production of prototypes is necessary. The number of objects and affiliated information are due to change since the specifications are working documents.

Newly developed and modified equipment are primarily tested at Äspö HRL and the Canister Laboratory in Oskarshamn. At these sites, facilities suitable for testing are available.

During 2019, a project aimed at designing the equipment needed for backfill installation has been active at Äspö. The project is described in the following sections.

4.2 Backfill installation equipment

Background

According to SKBs KBS-3V method canisters of copper with spent nuclear fuel will be deposited in deposition holes drilled vertically in the sole of tunnels, surrounded by a buffer of bentonite clay. The deposition tunnel is planned to be backfilled with blocks and pellets of bentonite clay. well executed installation ensures, together with the properties of the material, that the backfill fulfils its functions towards post-closure safety. The tasks can be performed by mainly standard equipment but some modifications have to be made.

Earlier development of the modular chassis concept was done in the project Transport System for Buffer and Backfill, Figure 4-1, and the concept of the universal chassis was developed further in the project Transport System for Buffer & Backfill and project Universal Chassis.

That project was conducted as a part of a joint effort together with a heavy transporter manufacturer. The choice of manufacturer Cometto Industries depended on the design parameters of the universal chassis, they already had a transporter called EMT (Electrical Modular Transporter) which fitted the design profile and they were willing to produce a customized version. It has a payload of approximately 20 tonnes.

The issue with only having a battery powered platform was addressed and the conclusion was that it is possible with minor modifications to adapt a hybrid solution into the EMT to make it more versatile for use in a final repository.

The concept of using a robot for the installation of the backfill was tested at a large-scale test in 2014 with promising but not completely satisfactory results, see Figure 4-2.

Objectives

The ongoing project Concept for Installation of Backfill is in the middle of conducting comprehensive tests with components of the system for installation of backfill that are identical or similar to those used in a final repository for spent nuclear fuel. A prototype for a universal chassis has been purchased and is under final testing before delivery, as well as an industrial robot of smaller size than the one used in earlier tests, Figure 4-3 to Figure 4-6.

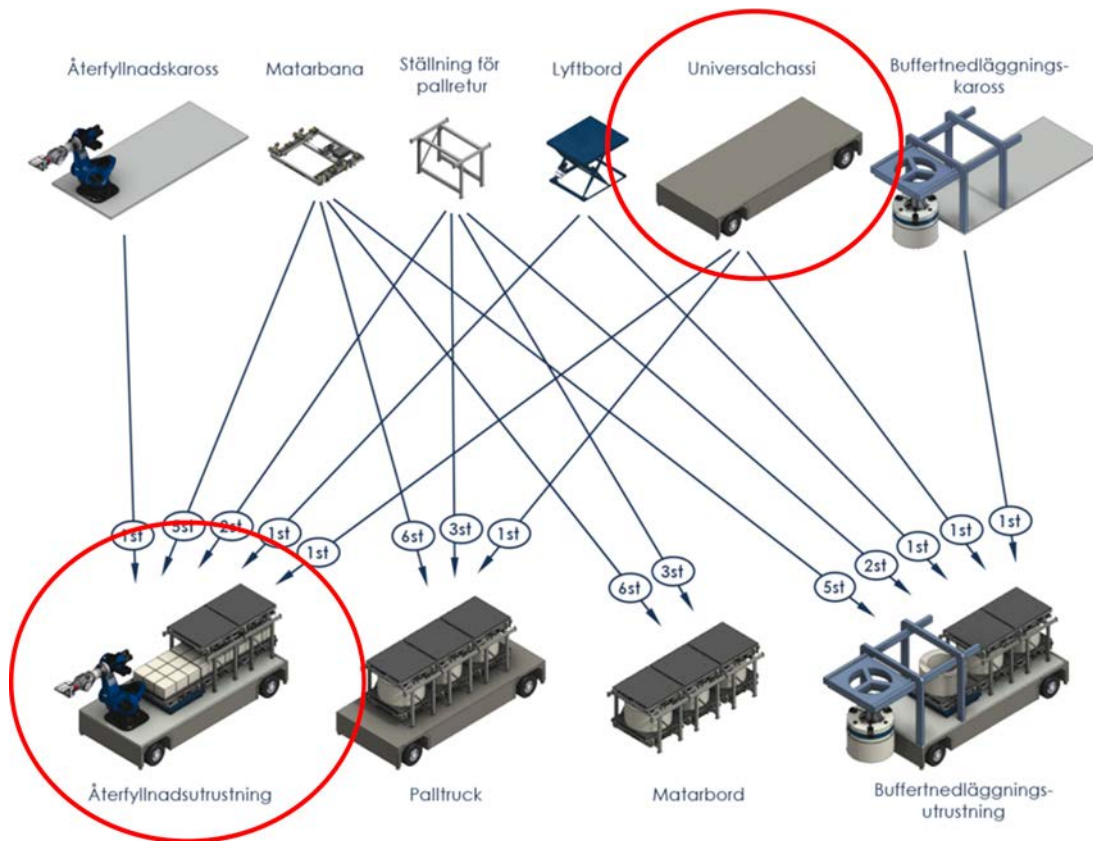

Figure 4-1. Modular chassis concept, with parts used for installation of backfill circled.



Figure 4-2. Robot stacking blocks in a full scale test in the Multipurpose test facility. Tests were also performed in the underground laboratory.



Figure 4-3. A smaller updated robot has been purchased in the project, software from the old one has been converted, and it is being tested together with transport equipment and pallets.

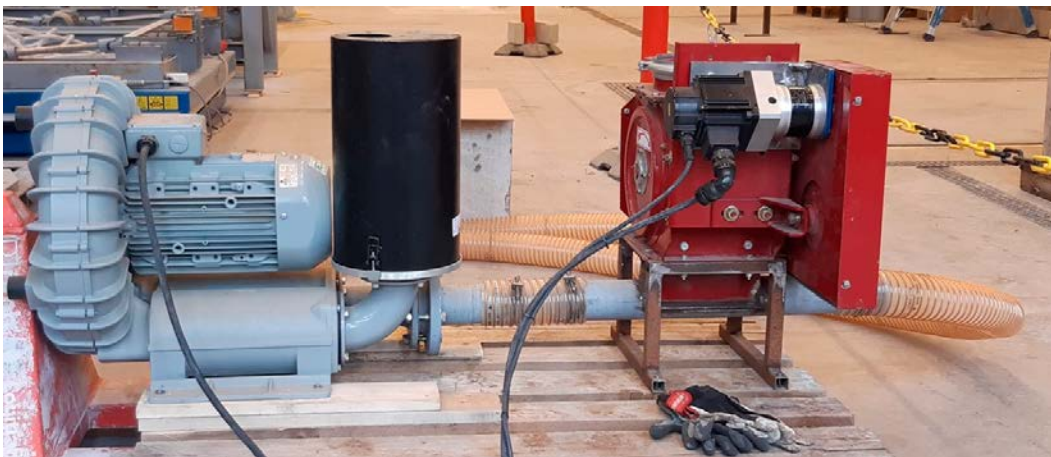

Figure 4-4. Equipment for installation of pellets in the void between the blocks and the tunnel wall.



Figure 4-5. Equipment for installation of a pellet bed on the tunnel floor.



Figure 4-6. *The Universal Chassis prototype at Cometto Industries in Cuneo, Italy, soon to be delivered to Äspö.*

Software developed in earlier projects and tests is being adapted and further developed. This system consists of:

- A supervisory system to control the route and driving of the equipment.
- Laser sensors which are used to scan the operating environment.
- Navigation system which enables the equipment to validate its route.
- An automated machine control system which in this case emulates the commands from an operator using a remote control.

Results

When the concept was tested the last time in 2012–2014 the results were promising but not completely satisfactory, the concept needed some more development, and since then the tunnel area of the reference design has changed.

Assembly, conversion and testing of the robot, preparations, planning and purchasing work was performed during 2019.

5 Äspö facility

5.1 General

The Äspö facility comprises the Äspö Hard Rock Laboratory and the above ground Research Village.

The facility has been introduced in Section 1.1 where the historic background, goals for the laboratory together with its organizational structure were presented. Layouts of the facility can be found in Figure 1-1 and 1-2.

This section gives a deeper explanation of the purpose of all different parts of the facility and their results during the year. Updated information is also available on communication activities and future strategies of the laboratory.

5.2 Multipurpose test facility

Before building a Spent Fuel Repository, further studies of the behaviour of the buffer and backfill materials under different installation conditions are required. SKB has constructed the Multipurpose test facility at Äspö, designed for studies of buffer and backfill materials. The laboratory has been in operation since spring 2007, and was previously called the Bentonite Laboratory. The name has been changed to reflect the breadth of research that is and can be performed in the facilities. The Multipurpose test facility enables full-scale experiment under controlled conditions and makes it possible to vary the experiment conditions in a manner which is not possible in the Äspö HRL.

The laboratory, a hall with dimensions 15×30 m, includes two deposition holes where the emplacement of buffer material at full scale can be tested under different conditions. The hall is used for testing of different types of backfill material and the further development of techniques for the backfilling of deposition tunnels.

Other equipment in the laboratory includes an Eirich bentonite mixer with a load capacity of 1 000 kg to allow mixing of bentonite with desired water ratio, and a KAHL press for fabrication of extruded pellets combined with a Baron CXL 4500 transporter and a CZ Multiscreen. The press produces extruded pellets with a diameter of 6 mm and a length of 20 mm. The production capacity is approx. 700 kg/h. A self cleaning filter system ensures a good working environment with low dust emissions.

In 2019 experiments have been performed in the Multipurpose test facility within several projects, such as Buffer pellet design (see section 3.3.1) and Backfill installation equipment (see section 4.2).

5.3 Material Science Laboratory

A research laboratory for bentonite analysis and experiments has been established on the Äspö facility, and is hosted by the department of Research and Post-closure Safety at SKB. The purpose of the laboratory is to act as a research and development infrastructure for bentonite investigations, supporting the research and technical development at SKB, including the very important competence buildup. The research laboratory is continuously evolving.

The laboratory is used in a number of projects and activities including technological development in (i) the material science projects, and for various research studies such as (ii) the analysis of long term field experiments such as LOT and Alternative Buffer Material (ABM), (iii) chemical erosion properties of bentonite, (iv) microbiological activity of sulphate reducing bacteria (SRB) at unsaturated conditions, and (v) evolution of gases in bentonite during unsaturated conditions.

During 2019 highest activity was from microbiological activity of sulphate reducing bacteria (SRB) at unsaturated conditions, atmosphere tests (Figure 5-1), erosion tests (Figure 5-2), and material characterisation (e.g. Figure 5-3).

The material characterisation studies were finished, and reported in Svensson et al. (2019).

The SRB-bentonite studies were finished, and reported in Svensson et al. (2020).

The infrastructure consists of equipment allowing handling, preparation, purification and analysis of bentonites, or investigation of important properties. This includes classical wet chemical analysis such as cation exchange capacity (CEC), exchangeable cations (EC), chemical reduction of iron (CBD), geotechnical measurements such as water content, density, swelling pressure and hydraulic conductivity, and solid state investigations using non destructive techniques such as X-ray diffraction (XRD) for mineralogy, X-ray fluorescence (XRF) for chemical content, infra red spectroscopy for detailed investigations of the clay mineral crystal structure, and μ -raman spectroscopy for investigations requiring high spatial resolution. A very large glovebox is also available for anaerobic studies or sampling of oxygen sensitive field samples. Recent upgrades are more advanced equipment for wet milling of bentonite samples, and a small photo studio for improved documentation of samples and experiments.



Figure 5-1. Deposition hole atmosphere test. Bentonite blocks, pellets and a copper heater are placed in a confined volume while oxygen, hydrogen and hydrogensulfide gases are monitored with time.



Figure 5-2. Experimental cell for measuring of chemical erosion of swelling clays. In this case the clay used is dialysed Nanocore at very low ionic strength in a 0.2 mm vertical fracture. The vertical placement show the impact from gravity on the sedimentation.



Figure 5-3. Naturally present smectite at -1100 m level in the Kiruna mine. These swelling clay minerals are very similar to bentonite and this location is very promising for a natural analogue study.

5.4 Water Chemistry Laboratory

History

The Chemistry Laboratory at Äspö HRL was built in the late 1990's. The main purpose is to perform the sampling and analyses on water samples collected in streams, lakes and boreholes in the surrounding area and the tunnel. The laboratory serves all of SKB and its projects, not only Äspö HRL.

The laboratory includes an on-site laboratory in Forsmark intended to aid the construction of the repository with sampling and water chemistry analysis for the site descriptive modelling. The information below concerns the work performed at Äspö.

The laboratory is certified in accordance with ISO/IEC 17025 Testing and calibration laboratories, and the overall certification was renewed by Swedac in October of 2018.

Analyses and equipment

For the moment the Chemistry Laboratory can perform 14 different analyses for water samples. Several of these analyses are accredited – pH, electrical conductivity, alkalinity, total organic carbon (TOC) and dissolved organic carbon (DOC), potentiometric measurements for chloride and fluoride, ion chromatography (IC) for anions such as chloride, bromide, fluoride and sulphate and UV/VIS spectroscopy for nitrogen as ammonia, sulphide and iron (Fe^{2+} and Fe^{tot}). The newest instrument is the Liquid Water Isotope Analyzer (LWIA) for determination of ^{18}O and ^2H and this analyse is also certified by Swedac since December 2019.

External laboratories are used for analysing cations (ex. sodium, calcium and sulphur), lanthanides and other trace elements, nutrient salts and isotopes such as ^3H , ^{34}S , ^{87}Sr and ^{37}Cl .

Performed activities

Once a year the Chemistry Laboratory performs a monitoring programme in the tunnel. At that time approximately 25 sections of different boreholes are collected and analysed at the laboratory. This programme has been ongoing since the tunnel was built in the 1990's and the data is used for modelling the groundwater in the HRL and understanding the area.

Quality control and quality assurance are performed every time an instrument is to be used. The results for both control samples and regular water samples are stored in a laboratory database (LabWare LIMS), see Figure 5-4. The chemistry laboratory has a useful and well described quality system for all the work that is done.

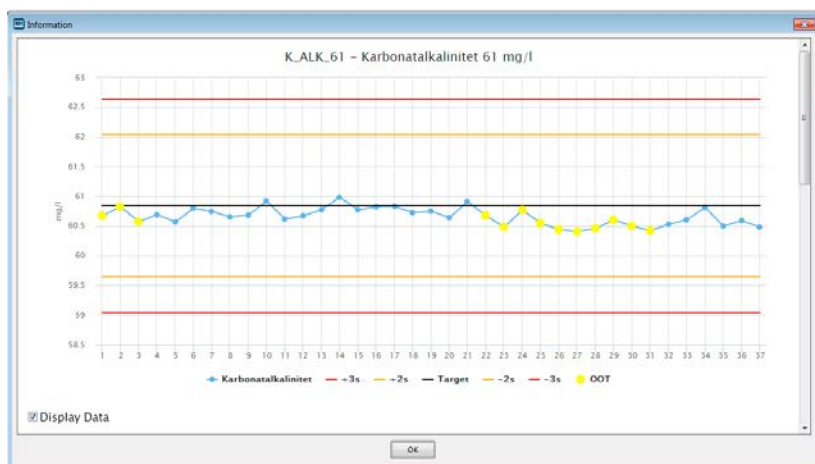

Figure 5-4. Example of control chart for the registration of control samples.

5.5 Facility Operation

Background and goals

The main goal for the operation of the rock laboratory is to provide a high service function and a customized availability for projects and external customers. The target was met well in 2019 despite great rock maintenance work and experiments.

The laboratories must also be safe for everyone who works or visits and for the environment. This includes preventative and remedial maintenance to ensure that all systems, such as drainage, electric power and lighting, ventilation, fire alarm systems, personnel monitoring systems and communication systems are always available in the underground laboratory.

Results

The plant has had a stable operation during 2019.

The independent stone inspection, carried out at the end of 2016, has led to the execution of previously identified activities in 2019 in different areas of the underground laboratory:

- Replacement of obsolete rock bolts.
- Exchange or addition of rock reinforcement networks.

The rock maintenance work in the tunnel system has been very good during 2019 and the work with activities from the stone inspection is expected to be completed in 2020.

In addition to rock maintenance, the following work has been carried out:

- Burglary alarms have been replaced with new from another supplier.
- Main gate is replaced.
- All the ground plan ports have been renovated to maintain fire rating.
- Extensive renovation work in the office section “library”.
- Washing and painting of facades and roofs.
- Review and exchange of evacuation lighting in the upper part of the tunnel.
- Preparatory work before replacing the mine lift cable.

5.6 Communication Oskarshamn

The main goal for the Communication unit in Oskarshamn is to create public acceptance for SKB. This is achieved by presenting information and showing SKB’s facilities and the RD&D work e.g. at Äspö HRL. The unit is responsible for visitor services at Clab and the Canister Laboratory as well.

In addition to the main goal, the unit organises visits for international guests every year. The international visits are mostly of technical nature, but increasing interest is shown regarding public acceptance of a geological disposal programme for high level radioactive waste.

The unit has a booking team which books and administrates all visits to SKB’s facilities. The booking team also works for Oskarshamn NPP’s service according to agreement.

External and internal communication activities carried out by the unit also range from local media relations, web and editorial work, school information and much more.

During 2019 the Communication Oskarshamn unit consisted of seven persons.

Special events and activities

During 2019, 1 902 persons visited the Äspö HRL and with the visitors to Clab and the Canister

Laboratory included, it resulted in a total of 3 067 persons. The total number of visitors to SKB's facilities in both Oskarshamn and Forsmark/Östhammar was 6 028 persons. The visitors represented the general public, students, professionals, politicians, journalists and international visitors. The total number of international visitors to the Äspö HRL was 290.

The special summer arrangement "Upptäck underjorden" (Discover the underground) was arranged during five weeks and 638 persons visited the underground laboratory. Tours for the general public also took place some Saturdays during the year.

During 2019, the school information officer visited schools and high schools within the Municipality of Oskarshamn to inform about SKB's work. The school information officer was part of "Innovation Camp" for second year students at the high school, arranged by "Ung Företagsamhet" (Young Enterprise). Students in the 3rd grade of high school were offered a visit to Clab. During 2019, the school information officer started to work with employer branding towards selected universities in Sweden

To celebrate the national event "Geologins Dag" (The Geological Day), the unit arranged a lecture on the local geology and history in area of Fredriksbergs manor in Oskarshamn on September 7, for an interested public.

On November 30, almost 100 competitors participated in "the Äspö Tunnel Race", a race where you run from the -450 meter level to surface. The winner was Gustav Runefors. He reached the surface after 18.22 minutes.

The two lectures for the public in were about the climate (May) and how a nuclear power plant is dismantled (November).

Every year members from the unit participate in "Almedalsveckan" in Visby.

5.7 Future use of Äspö HRL

SKB is conducting work with the intent to seek alternative possibilities for adaptation of the Äspö Hard Rock Laboratory into a national research and innovation infrastructure. The work is being spurred both by an active external interest in the planning for the future use of Äspö HRL and by internal long term strategic reasons. First of all the efforts are focused on finding out if there are external parties willing to individually or together with other parties financially support the operations of the Äspö underground laboratory. If such interest exists SKB will support the transfer of the ownership and the operations of the facility to a new owner. Otherwise, SKB will start to cease of the operations in 2024.

5.7.1 Planning prerequisites

The planning prerequisites for the current and future use of Äspö HRL are based on the strategic decisions that formed the basis of the latest reference cost calculations (Plan 2019). The strategic decisions were:

- SKB will have completed most of its ongoing and planned RD&D work in the Äspö underground laboratory by 2023.
- SKB has a continued need of all facilities in the research village on Äspö after 2023.

The first planning prerequisite (1) is a consequence of SKB intending to carry out the future final tests of the repository technology at repository depth in Forsmark. The remaining time until 2023 has deemed sufficient for the remaining RD&D work in the Äspö underground laboratory. The second planning prerequisite (2) concerns SKB's long term facility needs in Oskarshamn and a need of the existing above ground laboratory resources and infrastructure after 2023.

Based on these strategic decisions the following plans and activities have been initiated to support the continuation of the remaining work until 2023.

- Decommissioning of the Äspö underground facility will commence in 2024 based on the information available today.
- A feasibility study for decommissioning will start Q1 2020, which should also include Äspö Research Village.
- A limited but serious effort aimed at a potential new owner should take place in 2020 starting in Q1 2020.

5.7.2 Continuation or cease of operations in the Äspö underground laboratory

Given the planning prerequisites, work has been initiated to prepare and investigate two alternatives; a shift of operations in the Äspö underground laboratory, or alternatively a cease of operations in the Äspö underground laboratory.

It has been decided that a choice between the two alternatives has to be made in 2020 to have enough time for planning before the implementation in 2024. The following descriptions of the alternatives will be used as basis for the choice between the two alternatives.

- The continuation of operations is possible if one or several organisations (universities, institutes, WMOs or companies) are willing to financially contribute to the operational cost of the Äspö underground laboratory after 2023.
- Ceasing operations is carried out if no new possible managing organisation or organisations have shown the interest and ability to durably operate the underground laboratory after 2023. In this alternative, the Äspö underground laboratory is closed after SKB's own RD&D work is completed in 2023.

5.7.3 Status of the continuation of operations alternative

SKB has chosen to prioritise the continuation of operations alternative. SKB want to establish long term agreements with organisations with lasting ability and willingness to continue the operations of the Äspö underground laboratory. Several initiatives have been taken over the last years. The current situation for the most interesting ones is summarized hereinafter.

National Geosphere Laboratories (NGL)

SKB and the Municipality of Oskarshamn decided in 2011 to investigate the potential of Äspö HRL as a national infrastructure for research and innovation. This was the first and early proactive initiative to meet the foreseen phase-out of SKB's own R&D activities in the laboratory. Discussions were initiated with the Royal Institute of Technology (KTH) which resulted in the recommendation to qualify the laboratory as a national research infrastructure funded by the Swedish Research Council (VR).

Stockholm University became lead part in the NGL initiative, in cooperation with Uppsala University (UU), Lunds University (LU), Linnaeus University (LNU), Royal Institute of Technology (KTH), Chalmers University of Technology (CTH), Luleå University of Technology (LTU), Geological Survey of Sweden (SGU), Swedish University of Agricultural Sciences (SLU), SKB and the Municipality of Oskarshamn.

A nomination for NGL as a national research infrastructure was submitted to VR in spring of 2015. The application was well received by VR, and was graded A2 (second highest) meaning that NGL "has relevance to be considered a research infrastructure of national interest, but not yet ready for application period 2017".

Strengthened by the A2 grade, the parties proceeded with the NGL initiative, now led by KTH. A new yearly scientific meeting was held in 2016 with the title "NGL – The Underground Space Challenge". A preparation for a new application was initiated and was submitted to the Swedish Research Council (VR) in October of 2017. In May 2018 VR decided to not evaluate the application. This unexpected outcome has been analysed and the partners have decided to await the next infrastructure call which is expected to be announced in the spring 2021.

Baltic Sea Underground Innovation Network (BSUIN)

Since October 2017 SKB is participating in an international cooperation named Baltic Sea Underground Innovation Network (BSUIN). The cooperation runs for three years and is funded to 75 % by the EU Interreg BSR (Baltic Sea Region). Oulu University in Finland is lead part for the cooperation. The BSUIN network consists of 13 organisations including the lead part. Six of them are representing underground laboratories in Finland (1), Russia (2), Poland (1), Germany (1) and Sweden (1, Äspö HRL). In addition to Äspö HRL, the following five underground laboratories are participating in the project:

- Callio Lab in central Finland is situated in a 1 440 metres deep mine for copper, zink and pyrite mining. Experiment niches for other purposes are available at several depths in the tunnel. The mining operation is planned to be ended after 2019. There are plans to facilitate for other organisations and businesses to perform experiments and development work in the facility.
- Ruskela Lab in Russian Karelia is an older mining environment where marble has been mined since the 1700s. The facility runs from the surface down to 36 metres, and consists of several underground halls and open casts. In later years the area has become a tourist attraction and a site for testing and development of technology and methods for determining the strength of the rock and identifying weak rock zones. The goal is to use this knowledge to inform and guide other historical mining environments and to raise safety for staff and visitors.
- Russian Underground Low Background Laboratory of the Khlopin Radium Institute is an underground laboratory at 120 metres depth under the St Petersburg subway. The laboratory makes continuous measurements of tritium. The laboratory also has three gamma ray spectrometers with shielding from background radiation.
- Lab development by KGHM Cuprum Research and development Centre. The company KGHM Cuprum provides a comprehensive research and design service for mining industry. It operates in all service areas linked with mining activity, from project evaluation, through research and development, to project management and supervision of the implementation stage. The copper and salt mines owned and operated by the company are situated in the south west Poland. The largest and deepest (1 300 m) mine is situated in the vicinity of the town Polkowice, and has been in operation for 60 years. Areas where mining has ceased are available for experiments and testing and it is here an underground laboratory is planned. There is also an above ground laboratory for rock mechanical testing.
- Reiche Zeche in Saxony, Germany was originally a silver mine first taken in operation in 1839. It has for a long time been used as an educational site within mining technology and also for research. Today the facility is used by several institutions and companies to develop technology, production methods and materials for the mining industry. It is still used to train students in practical mining and investigation methods.

The common aim is to increase the use of the underground laboratories for innovation, business development and science. The methods used are by improving the information about the underground laboratories, the operation, user experiences and safety. The aim of the project is to develop and market a mutual and comprehensive offer to potential customers of the underground laboratories in the Baltic Sea region. This is intended to strengthen the innovation potential in the Baltic Sea Region.

BSUIN is also intended to become a viable network to be continued after the project end in September of 2020, likely in the form of a common association. Establishing the forms of cooperation is one of the main activities in the project.

Pre study – Test bed for development and innovation in rock engineering

In the spring of 2016, SKB and KTH Royal Institute of Technology initiated a meeting with Skanska to discuss if there was any interest from the construction industry to use Äspö HRL as a test bed for development and innovation in rock engineering. The discussion was positive and it was decided to, if possible, fund a feasibility study with funding from InfraSweden2030 (funded by Vinnova (Sweden's Innovation Agency)).

An application was submitted to the board of InfraSweden2030 in November of 2016. The board recommended Vinnova to fund the study, which was started in the beginning of 2017. The study was completed in the fall of 2017. The result of the study was used as a basis for a new application to the board and Vinnova to perform a deeper study (stage 2) including interested parties from other business areas such as geoenery. This new application got a positive response and the study was initiated with a planning meeting in March of 2018.

The completion of the pre-study has led to the conclusion that there is a need for a national test bed and that there is a broad interest in the Äspö laboratory as such. The Äspö laboratory can play an important role in developing the rock engineering issues within the framework of geosystem services in society in parallel with the more established and applied ecosystem services. However, there is considerable uncertainty regarding the future ownership of the Äspö HRL and how to deal with the future financing of the underground facility operations. Hence, the test bed development process has been paused waiting for SKB to take the next step.

Smart integrated test environment for the mining industry (SMIG)

In the SMIG project mining companies, equipment and system suppliers, specialized enterprises and universities are together developing a test bed for testing of systems, technologies and functions. Organisation, technical integration and system technology will be developed and several pilot tests will be performed. The project is carried out to meet mining industry's need of a test bed where systems and functions can be tested on the path towards the vision of "A fully automated mining process".

SKB's interest in the project lies in creating connections with the mining industry to make them aware and interested of Äspö HRL as a facility for testing and demonstration. The aim is to make Äspö HRL a part of the mining industry's test environment. The project is lead by LTU Business AB and will continue until mid 2021.

6 SKB International

6.1 Background history

SKB organised NWM, Nuclear Waste Management, as a department in SKB in order to manage international requests for consultations and transfer of methodology and technology in an efficient way. The international operation was in 2001 transferred to a separate company, SKB International Consultants AB, a wholly owned subsidiary of SKB. The name was changed in 2010 to SKB International AB. SKB International is the commercial arm of SKB and cannot draw any funds from the nuclear waste fund as the mother company SKB. SKB International offers technology, methodology and expert resources to international clients.

SKB International has full access to SKB's experts, technology facilities, laboratories and intellectual property. SKB International's services are based on the knowhow and hands-on experience accumulated by SKB in the development and operation of the Swedish nuclear waste management system. SKB International provides services to organisations and companies in spent nuclear fuel and nuclear waste management and disposal and hence provides the opportunity to save time and cost and to minimise risk. SKB International is committed to the safe disposal of spent nuclear fuel and radioactive waste generated in the operation and decommissioning of nuclear reactors. SKB International makes available SKB's special purpose vessel m/s Sigrid at times she is not occupied in SKB's programme. m/s Sigrid is roll on – roll off, lift on – lift off vessel with INF3 classification allowing transports of the highest class of radioactive cargo.

SKB International's main areas of operation are:

- Consulting services.
- Laboratory services.
- Training and competence development.
- Transports with m/s Sigrid.

6.2 Support and services related to Äspö

Äspö HRL is a unique research facility and there are only a few like it in the world. Almost 500 metres underground, SKB conduct experiments in collaboration with Swedish and international experts. The facility includes also the Äspö Village at surface with office space, different laboratories, a Multi-purpose test facility, etc.

Äspö HRL enables SKB to study the interaction of bentonite clay and copper canisters with the bedrock in realistic conditions. Experiments are made to identify the role of the bedrock as a barrier. This can, for instance, concern how the bedrock slows the movement of radioactive substances or how microbes affect conditions at repository depth. It is possible for other organisations to carry out their own research and experiments at the Äspö HRL. This can be organised through SKB International.

6.2.1 SKB International can customise following services:

Participation in SKB's experiments

SKB is using Äspö HRL for testing and verifying different technical solutions for the KBS-3 method at full scale under realistic conditions. In this report several experiments and demonstrations gives examples of activities which can be followed or joined by other organisations.

On the job-training

It is possible to arrange specific on the job-training activities for competence building of other organisations' staff.

Access to field data from 1986 until today

SKB has produced data from the site investigations of the Äspö island in the mid 1980s, from the construction phase of the Äspö HRL between 1990 to 1995 and from activities performed until today. Most of the field data can be made available for organisations, that may not have access to such data for the development of for instance methodology for site descriptive modelling.

Support to your organisation with tests and experiments

The staff at Äspö has long experience in planning, accomplishing and analysing tests and experiments. They are prepared to support other organisation which would like to perform own tests or experiments at Äspö HRL.

Workshops and training courses

SKB International has genuine experiences in arranging bespoke workshops and training courses and events on different topics. Experts from SKB covering different disciplines, e.g. long term safety, site investigations and selections, public relations, construction of under ground facilities are a key component in securing high quality activities.

Äspö International partnership

SKB International offers a unique partnership to organisations where they can get access to information from SKB's ongoing work performed at Äspö HRL. Meetings and workshops with SKB experts are organised annually for the partners. At these occasions partner organisations accuire good insite in to the ongoing work and the experiences SKB has developed over the past 40 years. The partners organisations can also follow the work and activities on site at Äspö.

A specific web-based site, the Äspö International Web Portal, is available to the partners. Information about Äspö HRL, including the Äspö village with the Chemistry and Material Science laboratories, Multipurpose test facility as well as the underground laboratory is presented. Also performed, ongoing and planned projects/experiments are presented. This allows the partners the opportunity to continuously follow planned and ongoing work and also to prepare for their own experiments.

Field data from the site investigations of Äspö HRL during 1986 to 1990, field data from the construction of Äspö HRL during 1990 to 1995 and the extensions made at can be made avaliable.

6.3 Activities and support during 2019

Äspö International partnership

SKB International arranged a number of events for the partners during 2019.

Two **topical workshops** were arranged, "Regional scale and tunnel scale modelling based on Äspö data" and also "Tunnel/shaft and deposition hole excavation".

The **Äspö International Web Portal** was updated with updated in relation to ongoing SKB projects.

The latest updated from the technical development work was presented at the annual **Technical Information Meeting**, TIM. The meeting covered the following topics:

- Overall Äspö information.
- Prioduktion of seposition tunnels and deposition holes.
- Detailed investigation methods during construction.
- Large scale test of casting of caissons for the extension of the SFR facility.
- Bentonite material study.
- Glacial effects on bentonite.

- Design of buffer and backfill.
- Techniques for block and pellets production.
- Sealing of investigation boreholes.
- Dismantling of the dome plug (DOMPLU).
- Dismantling of the LOT experiment.
- Dismantling of the Lasgit experiment.
- Machine development.

SKB presented planned activities for 2019 and the following years at the annual **International Joint Committee meeting**. Additional presentations on e.g. SKB's overall status and plans, knowledge management as well as Biosphere modelling were also made.

Training course

SKB International and SKB organised a scientific training course, School of Geological Disposal, (SGD2019), during November 2019. The training covered important issues governing nuclear waste disposal programmes. The course presented the planning and execution of a successful disposal programme based on the experiences gained by SKB during the past 40 years.. The starting point being a strategic and graded approach with an early safety prediction via detailed understanding of processes, research achievements and gains in correctly defined targets and how this leads to a communicative safety case based on a solid and well defined safety assessment. 30 participants from different organisations world-wide attended the course.

During the course of 2019 several bespoke training courses were executed, e.g. Tunnel and shaft excavation, Experiences from site investigations, Biosphere modelling, Pre-closure safety assessment, THM-modelling, etc.

6.4 Contact information

Are you interested in our assistance or do you need more information? Just contact us and we will help you out.

Mr. Magnus Holmqvist, President, Phone +46 70-641 18 28, email: magnus.holmqvist@skb.se

Mr. Erik Thurner, Senior Advisor, Phone +46 70-577 27 25, email: erik.thurner@skb.se

More information available at: www.skbinternational.se

References

SKB's (Svensk Kärnbränslehantering AB) publications can be found at www.skb.com/publications.

Abarca E, Idiart A, de Vries L, Silva O, Molinero J, von Schenk H, 2013. Flow modeling on the repository scale for the safety assessment SR-PSU. SKB TR-13-08, Svensk Kärnbränslehantering AB.

Andersson C, Johansson Å, 2002. Boring of full scale deposition holes at the Äspö Hard Rock Laboratory. Operational experiences including boring performance and a work time analysis. SKB TR-02-26 Svensk Kärnbränslehantering AB.

Bond A E, Hoch A R, Jones G D, Tomczyk A J, Wiggin R M, Worraker W J, 1997. Assessment of a spent fuel disposal canister. Assessment studies for a copper canister with cast steel inner component. SKB TR 97-19, Svensk Kärnbränslehantering AB.

Johannesson L-E, Hermansson F, Kronberg M, Bladström T, 2020. Manufacturing of large scale buffer blocks. Uniaxial compaction of block – test made with three different bentonites. SKB R-19-28, Svensk Kärnbränslehantering AB.

Johansson A J, Svensson D, Gordon A, Pahverk H, Karlsson O, Brask J, Lundholm M, Malmström D, Gustavsson F, 2020. Corrosion of copper after 20 years exposure in the bentonite field tests LOT S2 and A3. SKB TR-20-14, Svensk Kärnbränslehantering AB.

Kronberg M, Johannesson L-E, Eriksson P, 2020. Strategy, adaptive design and quality control of bentonite materials for a KBS-3 repository. SKB TR-20-03, Svensk Kärnbränslehantering AB.

Lagerblad B, Golubeva M, Cirera Rui J, 2016. Lämplighet för krossberg från Forsmark och SFR att användas som betongballast. SKB P-16-13, Svensk Kärnbränslehantering AB. (In Swedish.)

Lagerblad B, Rogers P, Vogt C, Mårtensson P, 2017. Utveckling av konstruktionsbetong till kassunerna i 2BMA. SKB R-17-21, Svensk Kärnbränslehantering AB. (In Swedish.)

Lundgren C, Johannesson L-E, 2020. Optimering av buffertpellets för KBS3 Laboratorieförsök på fyra olika pellets. SKB R-19-25, Svensk Kärnbränslehantering AB. (In Swedish.)

Luterkort D, Gylling B, Johansson R, 2012. Closure of the Spent Fuel Repository in Forsmark. Studies of alternative concepts for sealing of ramp, shafts and investigation boreholes. SKB TR-12-08, Svensk Kärnbränslehantering AB.

Mårtensson P, 2015. Äspö Hard Rock Laboratory. Concrete and clay. Installation report. SKB P-15-01, Svensk Kärnbränslehantering AB.

Mårtensson P, Kalinowski M, 2019. Äspö Hard Rock Laboratory. Concrete and Clay. Retrieval and analysis of experiment package #20. SKB P-19-18, Svensk Kärnbränslehantering AB.

Mårtensson P, Vogt C, 2018. Concrete caissons for 2BMA. Large scale text of design and material. SKB TR-18-12, Svensk Kärnbränslehantering AB.

Mårtensson P, Vogt C, 2020. Concrete caissons for 2BMA. Large scale text of design, material and construction method. SKB TR-20-09, Svensk Kärnbränslehantering AB.

Posiva SKB, 2017. Safety functions, performance targets and technical design requirements for a KBS-3V repository. Conclusions and recommendations from a joint SKB and Posiva working group. Posiva SKB Report 01, Posiva Oy, Svensk Kärnbränslehantering AB.

Railo A (ed) Laitinen I (ed), Mustonen S, Kosunen P, Joutsen A, Ikonen A, Nuijten G, 2015. Design and construction of the equipment and experimental deposition holes, in ONKALO Demonstration tunnel 1. Posiva Working Report 2015-25, Posiva Oy, Finland.

Railo A (ed) Laitinen I (ed), Mustonen S, Kosunen P, Joutsen A, Mellanen S, Ikonen A, Hollmen K, Nuijten G, 2016. Design and construction of the equipment and experimental deposition holes, in ONKALO Demonstration tunnel 2. Posiva Working Report 2016-27, Posiva Oy, Finland.

Sandén T, Nilsson U, 2020. Installation, monitoring, dismantling and initial analyzes of material from LOT test parcel S2 and A3. Results from field test. SKB TR-20-11, SvenskZKärnbränslehantering AB

Sandén T, Dueck A, Åkesson M, Börgesson L, Nilsson U, Goudarzi R, Jensen V, Johannesson L-E, 2017. Sealing of investigation boreholes. Laboratory investigations of sealing components. SKB P-17-10, Svensk Kärnbränslehantering AB

Sandén T, Nilsson U, Johannesson L-E, Hagman P, Nilsson G, 2018. Sealing of investigation boreholes. Full scale filed test and large-scale laboratory tests. SKB TR-18-18, Svensk Kärnbränslehantering AB.

SKB, 2001. RD&D-Programme 2001. Programme for research, development and demonstration of methods for the management and disposal of nuclear waste. SKB TR-01-30, Svensk Kärnbränslehantering AB.

SKB, 2010. Design, production and initial state of the closure. SKB TR-10-17, Svensk Kärnbränslehantering AB.

SKB, 2011. Long-term safety for the final repository for spent nuclear fuel at Forsmark. Main report of the SR-Site project. SKB TR-11-01, Svensk Kärnbränslehantering AB.

SKB, 2019a. RD&D Programme 2019. Programme for research, development and demonstration of methods for the management and disposal of nuclear waste. SKB TR-19-24, Svensk Kärnbränslehantering AB.

SKB, 2019b. Äspö Hard Rock Laboratory. Annual report 2018. SKB TR-19-10, Svensk Kärnbränslehantering AB.

Smart N R, Rance A P, 2009. Miniature canister corrosion experiment – results of operations to May 2008. SKB TR-09-20, Svensk Kärnbränslehantering AB.

Smart N R, Rance A P, Fennell P A H, 2006. Expansion due to the anaerobic corrosion of iron. SKB TR-06-41, Svensk Kärnbränslehantering AB.

Svensson D, 2015. The bentonite barrier – Swelling properties, redox chemistry and mineral evolution. PhD thesis. Centre for Analysis and Synthesis, Lund University.

Svensson D, Dueck A, Nilsson U, Olsson S, Sandén T, Lydmark S, Jägerwall S, Pedersen K, Hansen S, 2011. Alternative buffer material. Status of the ongoing laboratory investigation of reference materials and test package 1. SKB TR-11-06, Svensk Kärnbränslehantering AB.

Svensson D, Lundgren C, Johannesson L-E, Norrfors K, 2017. Developing strategies for acquisition and control of bentonite for a high level radioactive waste repository. SKB TR-16-14, Svensk Kärnbränslehantering AB.

Svensson D, Eriksson P, Johannesson L-E, Lundgren C, Bladström T, 2019. Development and testing of methods suitable for quality control of bentonite as KBS-3 buffer and backfill. SKB TR-19-25, Svensk Kärnbränslehantering AB.

Svensson D, Kalinowski B, Turner S, Dopson M, 2020. Activity of sulphate reducing bacteria in bentonite as a function of water availability. SKB TR-20-08, Svensk Kärnbränslehantering AB.

Svensson P D, Hansen S, 2013. Redox chemistry in two iron-bentonite field experiments at Äspö hard rock laboratory, Sweden: an XRD and Fe K-edge XANES study. *Clays and Clay Minerals* 61, 566–579.

Szabó Z, Dvinskikh S, Emmer Å, Svenberg L, Wold S, Mårtensson P, 2020. Äspö Hard Rock Laboratory. Project Concrete and Clay. Degradation of organic materials in cementitious environments. SKB TR-20-02, Svensk Kärnbränslehantering AB.

