

Report

P-15-10

December 2016



KBS-3H – DETUM Large fractures

Compilation of hydrogeochemical data
from groundwater sampling in boreholes
K08028F01 and K03009F01 at Äspö HRL

Bill Wallin

SVENSK KÄRNBRÄNSLEHANTERING AB

SWEDISH NUCLEAR FUEL
AND WASTE MANAGEMENT CO

Box 250, SE-101 24 Stockholm
Phone +46 8 459 84 00
skb.se

SVENSK KÄRNBRÄNSLEHANTERING

ISSN 1651-4416

SKB P-15-10

ID 1492007

December 2016

KBS-3H – DETUM Large fractures

Compilation of hydrogeochemical data from groundwater sampling in boreholes K08028F01 and K03009F01 at Äspö HRL

Bill Wallin, Geokema AB

Keywords: Compilation, Composition, Isotopes.

This report concerns a study which was conducted for Svensk Kärnbränslehantering AB (SKB). The conclusions and viewpoints presented in the report are those of the authors. SKB may draw modified conclusions, based on additional literature sources and/or expert opinions.

Data in SKB's database can be changed for different reasons. Minor changes in SKB's database will not necessarily result in a revised report. Data revisions may also be presented as supplements, available at www.skb.se.

A pdf version of this document can be downloaded from www.skb.se.

© 2016 Svensk Kärnbränslehantering AB

Abstract

A compilation was made of hydrogeochemical groundwater data obtained from the sampling of cored boreholes K08028F01 and K03009F01, drilled underground in the Äspö Expansion area. The groundwater samples were collected during the drilling phase as well as from packed-off sections in conjunction with hydraulic cross-hole interference tests.

The groundwater sampling during the respective drilling phases was made according to the procedures recommended for basic characterization sampling program in underground pilot boreholes. This sampling program was implemented and used during the preceding drilling of pilot boreholes in conjunction with the tunnel excavations of the Äspö Expansion program.

The groundwater sampling from borehole sections defined by multiple packers was made according to the standard procedures in order to characterize the hydrogeochemistry of the groundwater. The hydrogeochemical parameters were analysed in the Äspö Chemical Laboratory and external Laboratories in Sweden and abroad.

Identified key chemical parameters were used for a preliminary description of the groundwaters sampled in the two boreholes. This was made separately for each borehole, in order to briefly characterize the water type/-s and possible origin. A comparison of the hydrogeochemistry of the two boreholes was also made.

The results reveal that there is a significant variation in the dissolved elements of the groundwater between the sections of the two boreholes. In the borehole K08028F01 Cl and $\delta^{18}\text{O}$ suggest a typical complex mixing pattern with a dominant binary mixing. The variation in concentration of the dissolved components can be an indication a progressive dilution with a deep saline component. The hydrogeochemistry of borehole K03009F01 shows very homogeneous characteristics and the $\delta^{18}\text{O}$ values of the water imply that there is an in-mixed component of marine water which has undergone a sulphate reduction process.

The KBS-3H design has been developed jointly by SKB and Posiva since 2002. This report has been prepared within the project phase “KBS-3H – System Design 2011–2016”.

Sammanfattning

En sammanställning gjordes av hydrogeokemidata insamlade i kärnborrhålen K08028F01 och K03009F01, som är belägna i området för Äspö Utbyggnad. Vattenproverna samlades in dels under borrning samt i samband med hydrauliska interferenstester i sektioner avgränsade av manschetter.

Vattenprovtagningen under borrning genomfördes i överensstämmelse med procedurer rekommenderade för grundläggande karakterisering i pilotborrhål under jord. Dessa procedurer implementerades och användes under den föregående borrningen av pilotborrhål i samband med tunnelbrytning inom Äspö Utbyggnad.

Vattenprovtagningen från sektioner avgränsade av system med flera manschetter genomfördes i överensstämmelse med standardprocedurer för karakterisering av grundvattnets hydrogeokemi. De hydrogeokemiska parametrarna analyserades av Kemilaboratoriet på Äspö och av externa laboratorier i Sverige och utomlands.

Identifierande kemiska nyckelparametrar utnyttjades för en preliminär beskrivning av grundvattnet som provtagits i de två borrhålen. Detta utfördes först separat för respektive borrhål för att översiktligt karakterisera vattentyper och möjligt ursprung. Därefter följde en jämförelse av hydrogeokemin i de två borrhålen.

Resultaten visar att det finns en tydlig variation i lösta ämnen mellan sektionerna i de två borrhålen. I borrhål K08028F01 visar Cl och $\delta^{18}\text{O}$ typiska tecken på komplex omblandning med en predominant binär omblandning. Variationen i koncentrationen hos lösta ämnen kan utgöra en indikation på en progressiv utspädning med ett salt vatten från större djup. Hydrogeokemin i borrhål K03009F01 uppvisar en mer homogen karaktär där värden på $\delta^{18}\text{O}$ indikerar att det finns en inblandad komponent av marint vatten som har utsatts för sulfatreduktion.

KBS-3H är en variant av KBS-3 metoden som utvecklas gemensamt av SKB och Posiva. Denna rapport har utarbetats under projektfasen ”KBS-3H – System Design 2011–2016”.

Contents

1	Background	7
2	Definitions and abbreviations	9
3	Geographical references	11
4	Sampling during drilling	13
4.1	Number of samples for hydrogeochemistry during drilling	14
5	Sampling and analyses of groundwater from packed-off borehole sections	17
6	Results	19
6.1	Hydrogeochemical data in borehole K08028F01	19
6.1.1	Conservative parameters and major elements	19
6.1.2	Isotopes	22
6.2	Hydrogeochemical data in borehole K03009F01	22
6.2.1	Conservative parameters and major elements	22
6.2.2	Isotopes	26
7	Comparison of hydrogeochemical data from boreholes K08028F01 and K03009F01	29
8	Conclusions	35
	References	37
Appendix A	Tabulations of major element composition, isotopes, pH, conductivity, PmC and uranine concentrations of sampled groundwaters.	39

1 Background

During the SKB detailed site investigation programme, it is necessary to include data from different geoscientific disciplines in order to acquire a robust interpretation of the rock conditions. For this reason sampling for hydrogeochemistry was made in support of the hydrogeological and geological investigations in boreholes K08028F01 and K03009F01 within the project “KBS-3H DETUM Large Fractures”. The main purpose of this study is to compile the hydrogeochemical data and present the data in terms of binary plots, and briefly discuss the observed patterns. However, it must be emphasized that this work is not to be regarded as a modelling exercise. The other data collected within the different disciplines are interpreted separately, and are not further integrated here, but will subsequently be combined and further integrated in a single hole geoscientific interpretations (SHI), constituting a first step in better understanding the geology, structures and the groundwater system.

The objective of this report is to identify and illustrate major hydrogeochemical patterns and differences noted in groundwater samples from the two boreholes, serving as a first approximation and baseline to describe the characteristics of the groundwater. This has been made by combining both hydrogeochemical data from packed-off sections as well as from data from the preceding groundwater sampling during drilling. The hydrogeochemical data from sampling during drilling and packed off sections are presented together in binary plots to enable a comparison of the results of the two sampling methods.

The “Äspö Expansion programme” for groundwater sampling both during drilling and in packed-off sections after drilling was shown to be successful. The different groundwater sampling methods have been performed in order to a) obtain a so called “first strike” sample of the formation water during drilling, and b) to enable more detailed characterization and description of the formation water. A comparison of results from the two sets of sampling can be valuable to better understand possible anomalies recorded from either method.

Applicable internal SKB documents are presented in Table 1-1.

Table 1-1. The groundwater sampling has been made according to the following documents of methodologies and descriptions. The listed documents are internal unpublished documents written in Swedish.

Method	Description	Publication
SKB MD 452.001	Provtagning och provhantering (Sampling and sample handling).	Internal SKB document
SKB MD 452.007	Provtagning och provhantering (Sampling and sample handling).	Internal SKB document
SKBdoc 1378700-804	Baskarakterisering vid Äspölaboratoriet v0.8 (Basic characterization of groundwater at Äspö).	Internal SKB document
SKBdoc 1185972	Baskarakteriseringsprogram för Äspölaboratoriet (Basic characterization at Äspö).	Internal SKB document
SKBdoc 1355241	Detum-1 Metoder och Instrument – Kravspecifikation för utrustning för provtagning av grundvatten under borrhning (Specification of equipment and sampling procedures during drilling).	Internal SKB document
SKB MD 451.017	Provtagningstyper och felkällor (Sampling methods and error sources).	Internal SKB document
SKB MD 451.001	Akrediterings omfattning (Quality assurance).	Internal SKB document
SKBdoc 1452902	AP TD 3HDEMO-14-056 – Geovetenskaplig enhålstolkning av K08028F01.	Internal SKB document
SKBdoc 1461450	Analysrapport 20141124-A027 Interferenstester 2014.	Internal SKB document

The KBS-3H design has been developed jointly by SKB and Posiva since 2002. This report has been prepared within the project phase “KBS-3H – System Design 2011–2016”.

2 Definitions and abbreviations

Definitions and abbreviations used in the text and figures are accounted for below.

Abbreviation	Explanation
CDT	Canyon Diablo Troilite – (Standard for $\delta^{34}\text{S}$).
GMWL	Global Meteoric Water Line.
GWCM	Groundwater Chemical Monitoring (long term regular sampling).
m.a.s.l	Meter above sea level
PDB	Peedee Bee Belemnite Formation – (Standard for $\delta^{13}\text{C}$).
PmC	Percent modern carbon.
REE	Rare Earth Elements.
SECMID	Middle position in a packed-off borehole section.
SMOW	Standard Mean Ocean Water – (Standard for $\delta^{18}\text{O}$).
TASU	Tunnel U, shooting off from the main access tunnel (TASA).

3 Geographical references

The boreholes K08028F01 and K03009F01 (Nilsson 2016) are drilled from the TASU tunnel as shown in the Figure 3-1.

Table 3-1. Basic data for boreholes K08028F01 and K03009F01. The horizontal coordinate system is ÄSPÖ96 and elevation coordination system is RHB70 (Hjerne et al. 2016).

Borehole	K08028F01	K03009F01
Diameter [mm]	75.8	75.8
Length [m]	94.39	100.92
Inclination (°)	+2.18	-0.37
Bearing (°)	320.366	330.9995
Coordinates for starting point		
Northing (m)	7450.637	7415.816
Easting (m)	2386.037	2368.412
Elevation (masl)	-396.612	-399.226

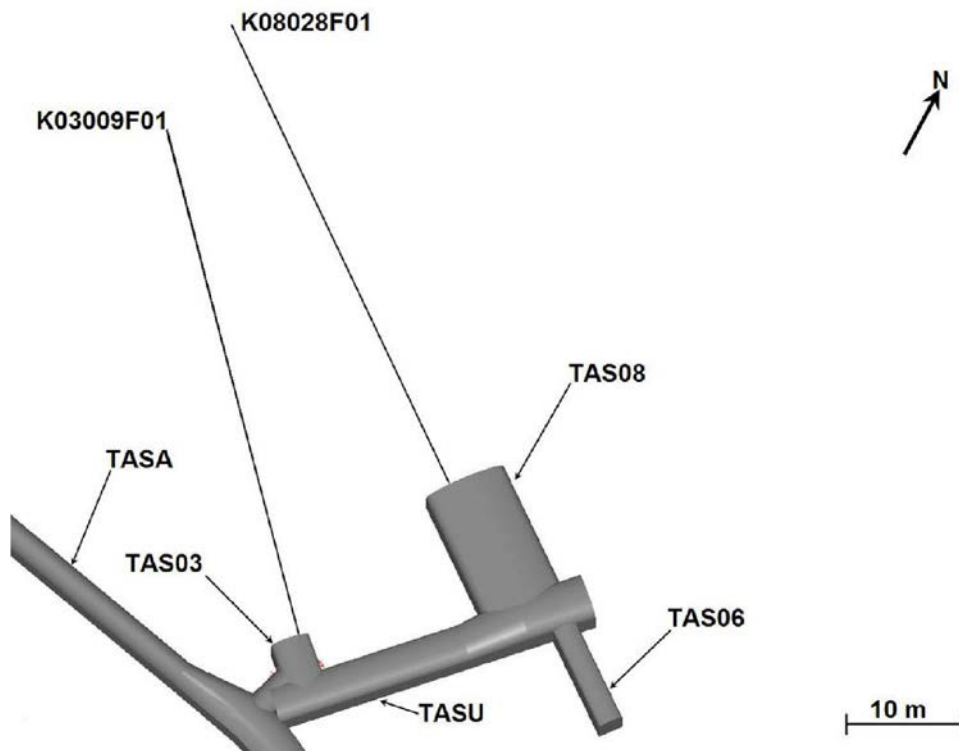

Figure 3-1. a) Plan view of the Äspö Expansion area and the two boreholes in the TASU tunnel.

4 Sampling during drilling

Sampling for hydrogeochemistry was performed by means of the so-called “basic characterization sampling program”. This means that the sampling took place in conjunction with the drilling, obtained from the return water and collected according to chemical class 3 (according SKB sampling program SKB MD 452.001, SKBdoc 1378700, SKBdoc 1355241, SKB MD 451.017, SKB MD 451.001).

The drilling water was labelled with uranine as a tracer during the drilling process and its concentration was constantly monitored in the field in order to ensure sampling of formation water, as shown in Table 4-1 and Figures 4-1 and 4-2. Groundwater and return drilling water was collected in 5 L buckets for chemical analyses. The threshold level for accepting a drilling water sample is 0.20 mg/L, although there are variations according to the data listed in Table 4-1 below. The concentrations of the dissolved components of the in-mixed groundwater in the return water which is sampled during drilling has been calculated by measured residual uranine concentration, reported in Table A-2 for each sample, in relation to the initial 0.2 mg/L threshold.

The reason for sampling during drilling is to obtain point-wise fingerprints of the groundwater along the whole borehole length at a certain time. Hence, the water sample is a mixture of formation water fed by the conductive fractures over the accumulated drilled distance and returning drilling water. In order to have control of the concentrations of the dissolved components of the drilling water, sampling for the dissolved uranine in that water was constantly made on the drilling water entering into the borehole in conjunction with the drilling as shown in Table 4-1.

Table 4-1. Borehole length at which drilling water was sampled, date of sampling and associated uranine concentration measured prior to entering into the borehole. Uranine concentration of the sampled groundwater is reported in Table A-2 of Appendix A.

Borehole	Date	Borehole length (m)	Uranine (mg/L)
K08028F01	2004-06-03	2.28	0.27
K08028F01	2014-06-06	27.87	0.22
K08028F01	2014-06-08	40.69	0.22
K08028F01	2014-06-09	58.88	0.21
K08028F01	2014-06-09	66.06	0.19
K08028F01	2014-06-10	72.79	0.22
K08028F01	2014-06-11	77.05	0.22
K08028F01	2014-06-11	86.12	0.19
K08028F01	2014-06-12	89.04	0.23
K03009F01	2013-11-27	4.95	0.19
K03009F01	2013-11-27	9.57	0.26
K03009F01	2013-12-04	17.20	0.22
K03009F01	2013-12-04	21.47	0.23
K03009F01	2013-12-07	49.16	0.26
K03009F01	2013-12-07	53.11	0.22
K03009F01	2013-12-08	54.53	0.24
K03009F01	2013-12-08	54.59	0.21
K03009F01	2013-12-10	75.44	0.20
K03009F01	2013-12-10	78.37	0.20
K03009F01	2013-12-10	83.11	0.20
K03009F01	2013-12-10	86.13	0.22
K03009F01	2013-12-11	94.99	0.23

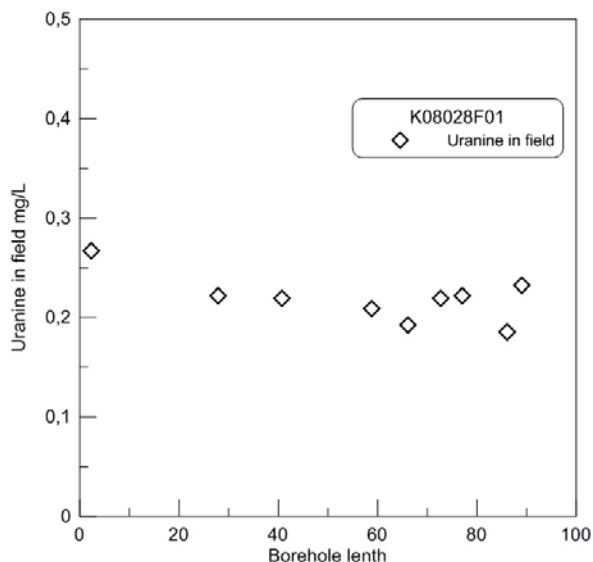

Figure 4-1. Field uranine concentrations in the input drilling water plotted versus borehole length in borehole K08028F01 during monitoring of the drilling water.

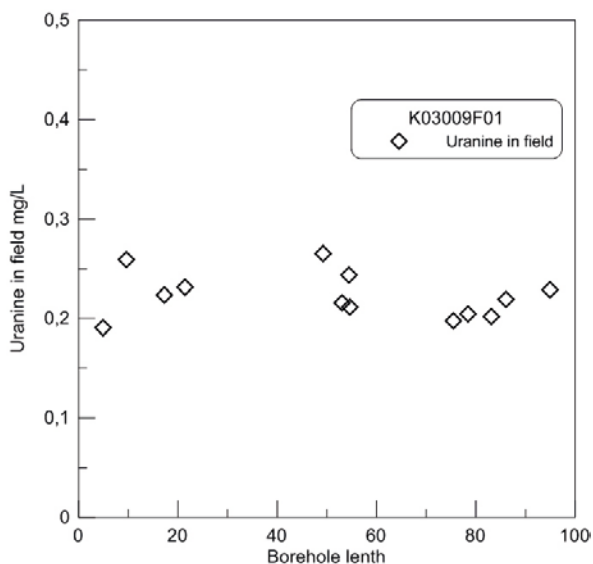

Figure 4-2. Field uranine concentrations in the input drilling water plotted versus borehole length in borehole K03009F01 during monitoring of the drilling water.

4.1 Number of samples for hydrogeochemistry during drilling

The sampling for hydrogeochemistry during drilling was made at one occasion (2014-06-10) in borehole K08028F01 over the borehole length between 0 to 69.05 m, and at five different occasions (2013-11-12, 2013-11-27, 2013-11-29, 2013-12-05 and 2013-12-08, respectively) in borehole K03009F01 over the borehole lengths of 0.34–2.55 m, 0.0–10.82 m, 0.0–15.50 m, 0.0–26.22 m and 0.0–62.24 m.

The hydrogeochemistry established on the basis of these groundwater samples are presented in Table A-1 and Table A-2 in the Appendix. The results are discussed in Section 6 and Section 7 together with the groundwater chemistry data from the packed-off sections. This to enable a better understanding of the hydrogeochemistry established by way of the two different sampling methods. As an example uranine (drillwater content in %) is plotted versus borehole length both for water samples from drilling and packed-off sections in the two boreholes in Figure 4-3 and Figure 4-4, respectively. In borehole K03009F01 one sample and in borehole K08028F01, two samples extracted during the drilling show considerably higher uranine concentrations in comparison to the subsequent packed-off section water samples.

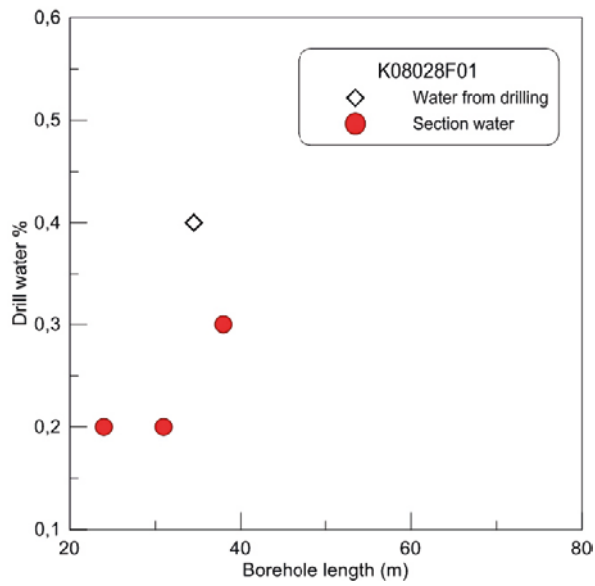

Figure 4-3. Percentage of drilling water plotted versus borehole length in borehole K03009F01 as obtained from groundwater sampling.

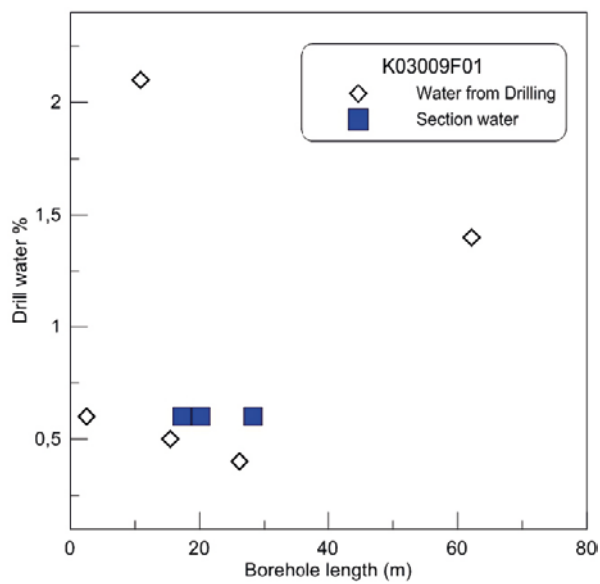

Figure 4-4. Percentage of drilling water plotted versus borehole length in borehole K08028F01 as obtained from groundwater sampling.

5 Sampling and analyses of groundwater from packed-off borehole sections

The groundwater was sampled for hydrogeochemistry from sections defined by packers. The water collected and analysed from sections is assumed to represent an average of the different flowing features identified in the respective borehole section. As a rule of thumb, generally a turnover of 3–5 section volumes is required to obtain a representative sample. However, in this case and based on the distribution of transmissivities and section length, the water volume in the section was withdrawn during a time period, calculated from the section volume and fracture transmissivity, to facilitate sampling of a representative section water. This was achieved by making a prior estimate of the section volume and groundwater flow in the section. In addition, the sampling was performed after the hydraulic interference tests in the respective borehole (Hjerne et al. 2016), which suggest that sufficient volumes of water were extracted from the sections prior to the hydrogeochemical sampling.

Groundwater sampling in borehole K08028F01 was performed from three sections, namely from 19–29 m (K08028F01:7), 30–32 m (K08028F01:6), and 37–39 m (K08028F01:4). Groundwater sampling in borehole K03009F01 was performed from three sections, namely from 14.2–17.2 m (K03009F01:7), 17.2–20.20 m (K03009F01:6) and 25.2–28.2 m (K03009F01:4).

The water from the sections was sampled according to Class 5 (SKB MD 452.001), which includes analyses of cations, anions, trace elements, REE, stable and radioactive isotopes and physical parameters such as pH, electrical conductivity and temperature. The hydrogeochemistry results from the sampled groundwaters are presented in Tables A-1 and A-2 in Appendix A.

Anions like Cl and Br were analysed at the Äspö laboratory and pH, conductivity and temperature were measured in the field as well as in the laboratory. Water samples for analyses of cations, anions, trace elements, REE and isotopes were shipped to and analysed in external laboratories in Sweden and abroad.

The electrical conductivity of the water is affected by the presence of inorganic dissolved solids such as chloride, nitrate, sulfate and phosphate anions and/or cations such as sodium, magnesium, calcium, iron and aluminum. Hence, a salinity assessment can be readily made by plotting electrical conductivity versus chloride of the groundwater (which normally gives a typical linearity) as a first approximation to see if there are any inconsistencies in the dissolved components and/or any charge imbalances.

As can be seen in Figure 5-1 the conductivity and chloride are near linearly correlated as expected. This is a clear indication that there is a normal distribution of the dissolved ions and charge balance of the waters sampled from the packed-off sections.

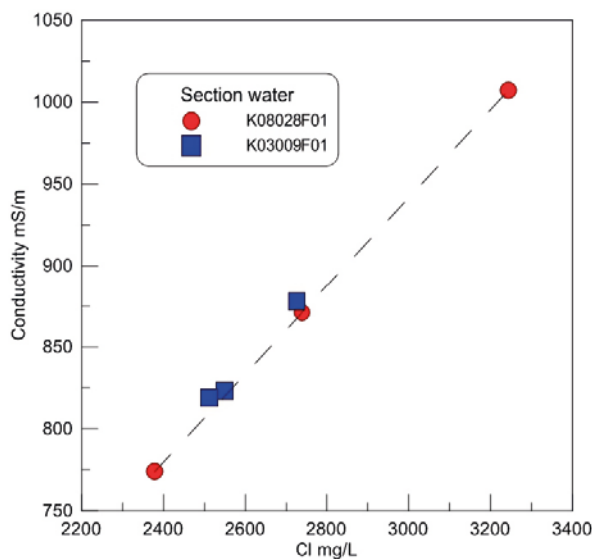

Figure 5-1. Conductivity plotted versus chloride in the groundwater sampled from section in K08028F01 and K03009F01.

6 Results

The results from the hydrogeological sampling are quality assured and stored in the Sicada database. A working file has been extracted and used for this study including all parameters that has been analysed.

The major elements are given in terms of concentration (mg/L), the trace element concentrations are presented as µg/l. The strontium isotope data are given as ratios, stable isotopes in per mille (‰) deviations versus standards, temperature in °C, electrical conductivity in mS/m and ¹⁴C data is also presented as pMC. The standards used for δ²H and δ¹⁸O are SMOW, for δ¹³C is PDB and for δ³⁴S is CDT.

The data used in this study are presented in Appendix in Table A-1 and A-2. The major elements are listed in Table A-1, isotope data together with some physical parameters are listed in Table A-2. The major elements and isotopes are presented and discussed in Section 6 to 7. The conservative parameters Cl and δ¹⁸O have been used to delineate trends and relations between the dissolved components, major elements have been used to characterize the waters and the isotopes have been used to delineate the differences between the waters from the two boreholes. The hydrogeochemical data from sampling during drilling and packed-off sections are presented together in binary plots to enable a comparison between the results of the two sampling methods.

6.1 Hydrogeochemical data in borehole K08028F01

A general scrutiny of the data reveals that there is a significant variation in the dissolved parameters of the groundwater between the packed-off sections. This is most likely an indication of a mixing between different waters. The data can be used to confirm and/or support other geochemical/geological observations.

A more detailed presentation of the variation of the major elements and isotopes is made in Section 6.2 by use of standard diagrams. This will provide an initial understanding of the groundwater system.

6.1.1 Conservative parameters and major elements

The Cl concentrations in the groundwater sampled from borehole K08028F01 show a variation between 2373 to 3243 mg/L. As a first approximation it seems that e.g. conductivity versus Cl displays a typical relationship to all three datasets from the section waters, and therefore looks like a binary mixing line (Figure 6-2), which essentially is explained as a two component mixing. However, when plotting Cl versus δ¹⁸O this pattern is not as evident as seen in the plot of electrical conductivity versus Cl, although there is a general trend of increased δ¹⁸O with decreased concentration of Cl.

Only one section, at 19–29 m, is corresponding with an interpreted potential deformation zone in the borehole. In this section (where deformation zone DZ1 zone is found) the δ¹⁸O value is -10.1 ‰ (SMOW), indicating that there is a relatively large component of meteoric water. A similar value (-10.6 ‰), is found in the section 30–32 m, whereas in the section 37–39 m there is a considerably higher δ¹⁸O value of around -8.7 ‰, consistent with an in-mixed deeper saline or marine water component. In contrast there is a general decrease in chloride with increase in δ¹⁸O value in the section waters (Figure 6-1). This is hard to explain and one would expect the inverse pattern, and therefore a plausible explanation is that there is also an in-mixed portion of fresh water in the section at 19–29 m.

This inconsistency of δ¹⁸O value between the three sections may simply represent different waters, as observed by plotting conductivity versus Cl.

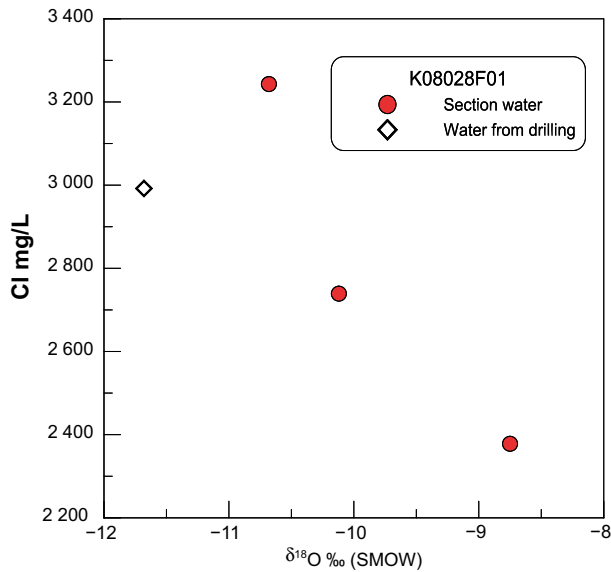

Figure 6-1. Cl plotted versus $\delta^{18}\text{O}$ in the sampled section waters and the water sampled during drilling.

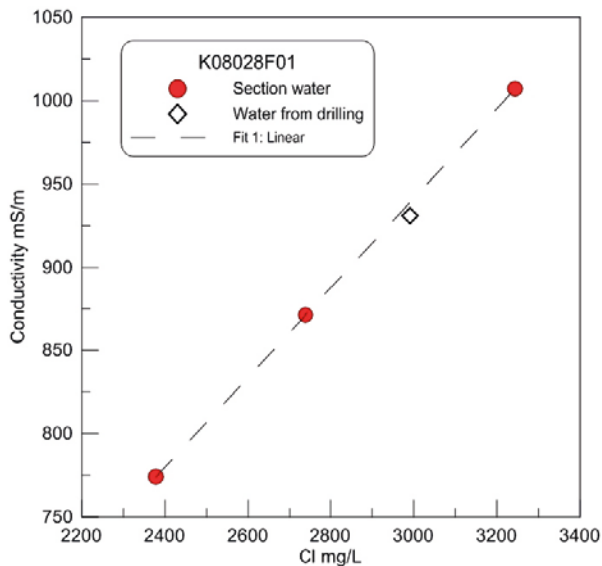

Figure 6-2. Conductivity plotted versus Cl in the sampled section waters and the water sampled during drilling.

When looking at the major element data from the three packed-off sections different patterns emerge, e.g. when plotting Mg versus Cl a clear linear trend does not appear. On the other hand HCO_3^- plotted versus Ca shows a linear trend as seen in Figure 6-4. In addition, the relatively low Mg concentrations in relation to the Cl concentration in the section waters indicate a deeper saline component rather than a marine component. This finding is supported when plotting Ca/Mg versus Br/Cl as shown in Figure 7-8 in Section 7. Also the high $\delta^{18}\text{O}$ value around 8.7 ‰ for one water sample is still hard to explain (Figure 6-1). A plausible explanation for this observation may be a dilution of a minor marine component with freshwater concentrations. A tentative conclusion from this therefore is that the DZ1 zone communicates with waters at shallower depth in the crystalline basement rock, fed by a meteoric water source.

The other two sections K08028F01:6 and K08028F01:7 do not overlap any other deformation zone, however, as mentioned above when plotting Cl versus other parameters a linear relationship appears and is referred to as a mixing line.

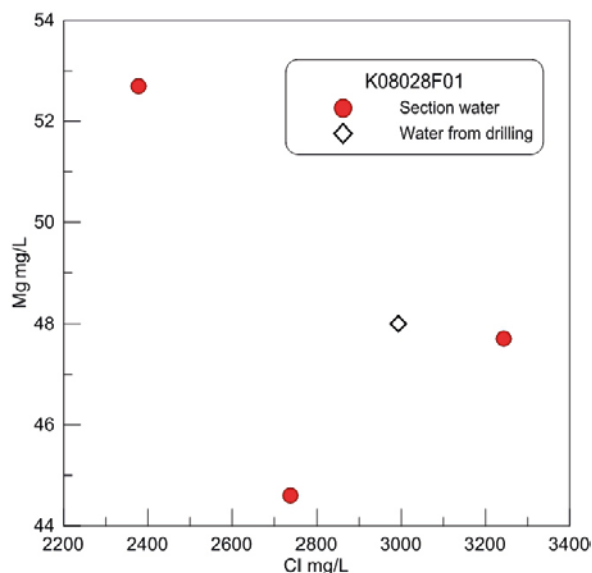

Figure 6-3. Mg plotted versus Cl for the sampled section waters and the water sampled during drilling.

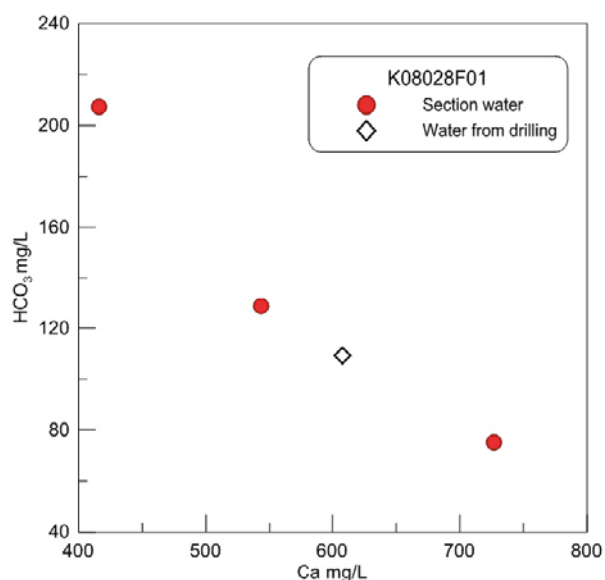

Figure 6-4. HCO₃ plotted versus Ca for the sampled section waters and the water sampled during drilling.

The carbonate system shows that there is a general increase in bicarbonate with a decrease in Ca concentration, cf. Figure 6.4. The Ca concentration varies between 416 and 727 mg/L, which are very high values for Äspö groundwaters at this depth (–396 m.a.s.l). As a comparison, the Baltic seawater has a Ca concentration of about 94 mg/L. Also the HCO₃ values (varying between 75 to 207 mg/L) are elevated in comparison to Baltic seawater. The most likely explanation for the higher Ca concentrations is that there is a deeper saline component and/or there has been considerable calcite dissolution in these waters.

Sodium also plots versus Cl in a near linear relationship. The linearity shown is clearly a result of a mixing, presumably a two component mixing. However, as we know from previous work (Laaksoharju et al. 2009) it may not be that simple and could therefore also be an integrated mixture of other waters, including a meteoric water component, as mentioned for the $\delta^{18}\text{O}$ values above (Figure 6-5).

In conclusion, the overall patterns from the major elements suggest that there is a progressive dilution and/or linear mixing/regression of the waters in the basement in the vicinity of the sampling points as seen from the chemistry in the three sections. This observation is supported by the results from the sample taken in the first strike during the drilling, cf. Figure 6-5) However, the higher $\delta^{18}\text{O}$ value for one water sample, as seen in Figure 6-6, suggests a slightly different water, possibly a mixture of freshwater and a deep saline water.

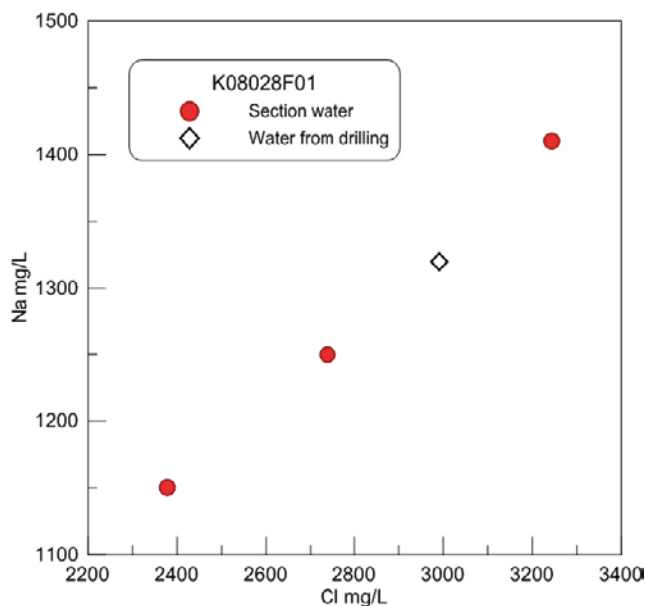

Figure 6-5. Na plotted versus Cl for the sampled section waters and the water sampled during drilling.

6.1.2 Isotopes

The plot of $\delta^2\text{H}$ versus $\delta^{18}\text{O}$ in Figure 6-6 shows a wide isotopic variation between the different section waters sampled. Since they show a near linear relationship it again provides support for a possible mixing of different waters. Also the data point representing the water from drilling falls on the same extrapolated line as the section waters. During the drilling the local fresh tap water was used which is mainly made up of meteoric water from the Äspö area. Hence, this confirms the conclusion that there is a portion of in-mixed drilling water in the sampled section waters, as mentioned in Section 6.2.

The $\delta^{13}\text{C}$ in the dissolved bicarbonate varies between -15.7 and -16.9 ‰ (PDB). This indicates a mixture of an inorganic and organic carbon source. There is a slight decrease in $\delta^{13}\text{C}$ with increased HCO_3^- , which may be resulting from microbial activity in the groundwater (Figure 6-7).

Sulphur isotopes of the dissolved sulphate vary between $+24.8$ and $+27.5$ ‰ (CDT) as seen in Figure 6-8. The slightly elevated values in comparison to a marine signature, which is around $+20$ ‰ (Clark and Fritz 1997) indicate that a sulphate reduction has been taking place in the groundwater.

6.2 Hydrogeochemical data in borehole K03009F01

As a first approximation the groundwaters from the three sections sampled seem to be rather homogeneous with respect to their characteristics and show less variation in comparison with the groundwater data in K08028F01, cf. Section 6.1. The data can be used as to confirm and/or support other geochemical/geological observations. A more detail presentation of the variation of the major elements and isotopes are made below in Section 7.1.

6.2.1 Conservative parameters and major elements

The Cl concentration in the groundwater sampled in K03009F01 varies between the three sections from 2511 to 2757 mg/L. These are lower concentrations than e.g. seen in Baltic seawater, which is around 3750 mg/L (Wallin et al. 2007). However, there seems to be a smaller component of in-mixed integrated saline water and a marine seawater component (possibly Baltic water) as

indicated by relatively high $\delta^{18}\text{O}$ values, varying between -7.4 and -7.9 ‰ for all three section waters (Laaksoharju et al. 1999, Wallin et al. 2007). However, one would in that case expect higher Mg concentrations than those seen in these water (Figure 6-12). There is a typical linearity between Cl and $\delta^{18}\text{O}$ as seen in the plot in Figure 8-1. The water from drilling also displays a linear trend, although it shows a clearly different slope and difference in magnitudes. The depleted $\delta^{18}\text{O}$ values in the waters from drilling are due to the fact that tap water with local meteoric signatures is used for the drilling.

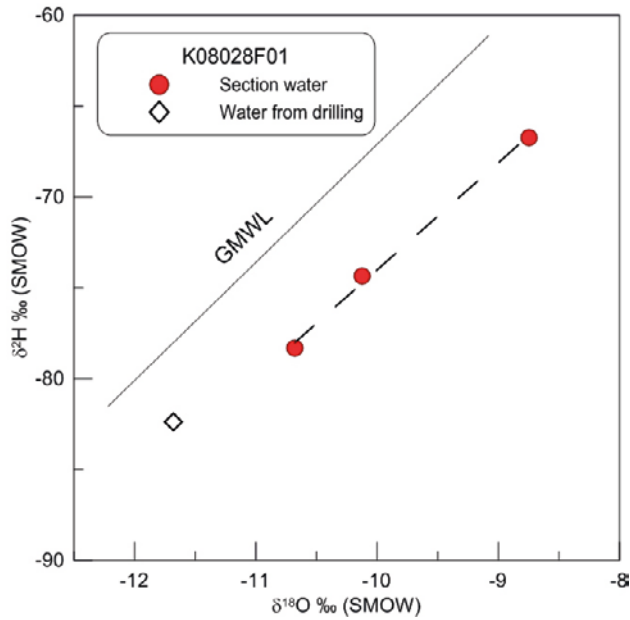

Figure 6-6. $\delta^2\text{H}$ plotted versus $\delta^{18}\text{O}$ for the sampled section waters and the water sampled during drilling.

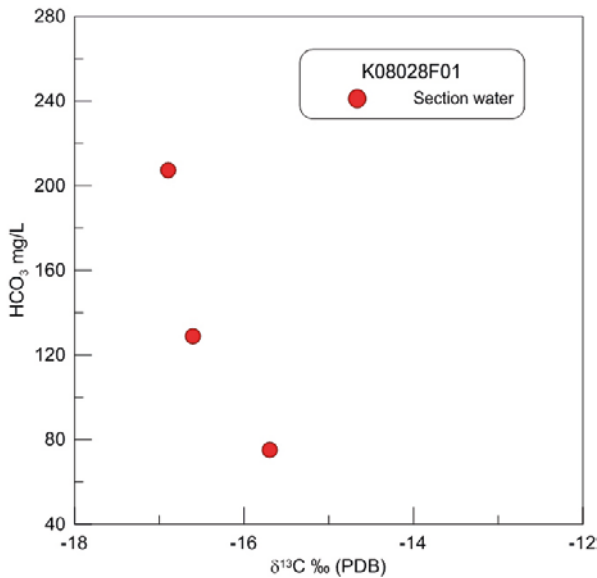

Figure 6-7. HCO_3^- plotted versus $\delta^{13}\text{C}$ in the dissolved HCO_3^- for the sampled section waters and the water sampled during drilling.

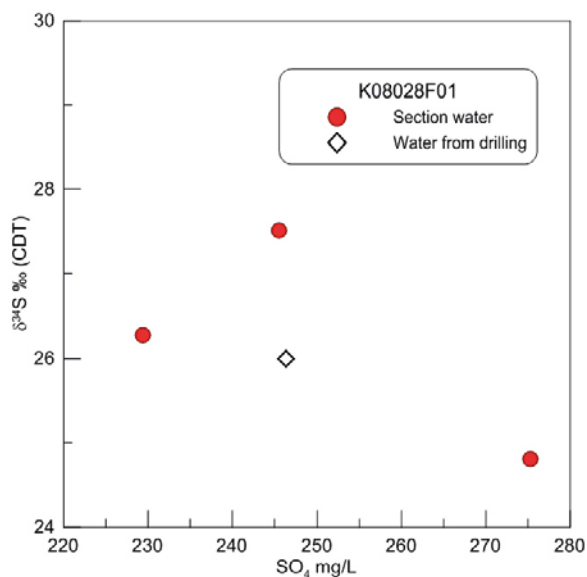

Figure 6-8. SO_4 plotted versus $\delta^{34}S$ in the dissolved SO_4 for the sampled section waters and the water sampled during drilling.

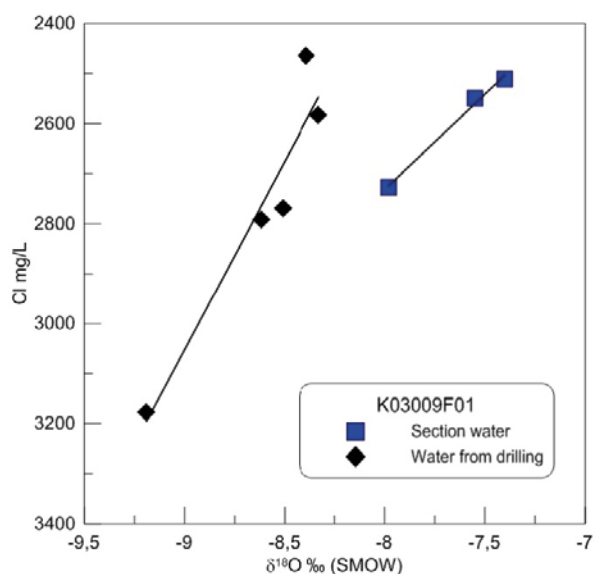

Figure 6-9. Cl plotted versus $\delta^{18}O$ for the sampled section waters and the waters sampled during drilling.

The difference in $\delta^{18}O$ signature seen from the two sampling methods appears even stronger in the plot of δ^2H versus $\delta^{18}O$ in Figure 6-10. There are almost parallel slopes seen in the data based on the samples from drilling and section water, respectively.

The electrical conductivity plotted versus Cl shown in Figure 6-11 shows linearity between the section waters and waters sampled during drilling with one value being extreme. The latter may reflect inflow of more saline water residing in limited pockets and/or fractures during the drilling. However, it is peculiar that the drilling water attain higher Cl concentrations than the section water.

The Mg concentrations in section waters (variation between 82.8 and 91.3 mg/L) and waters from drilling (79.1 to 86.9 mg/L) are plotted versus Cl in Figure 6-11. There are no clear trends or relationships between the two parameters.

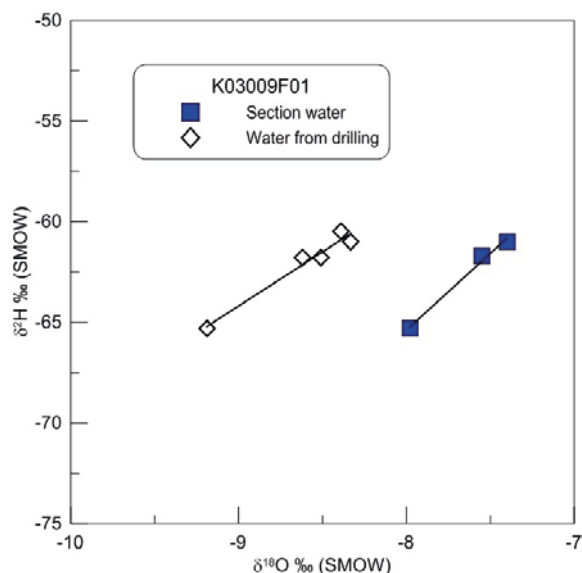

Figure 6-10. $\delta^2\text{H}$ plotted versus $\delta^{18}\text{O}$ for the sampled section waters and the waters sampled during drilling.

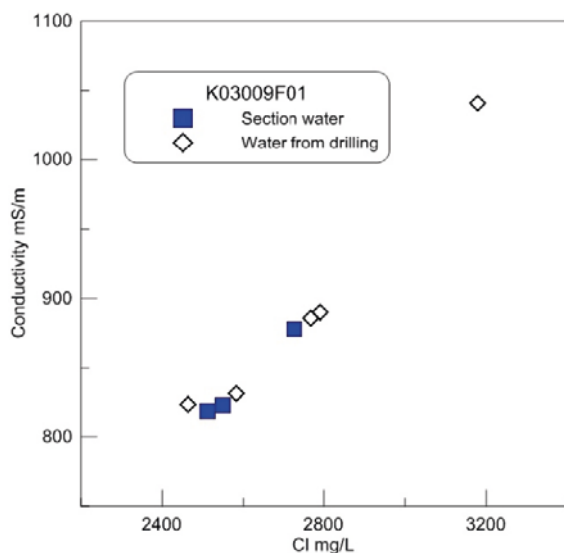

Figure 6-11. Conductivity plotted versus Cl for the sampled section waters and the waters sampled during drilling.

The Ca concentrations vary between 349 and 444 mg/L which are considerably lower than seen in the neighboring K08028F01. The carbonate system shows a similar trend as in borehole K08028F01 with an increased HCO_3^- with decreased Ca concentration, cf. Figure 6-13. The plausible explanation for this finding is that calcite dissolution is taking place.

Sodium concentrations are very homogeneous between 1320 and 1390 mg/L. There is no clear linearity between Na and Cl, which was to be expected. An explanation for this may be some disturbances in the water due to e.g. ion exchange between Ca and Na.

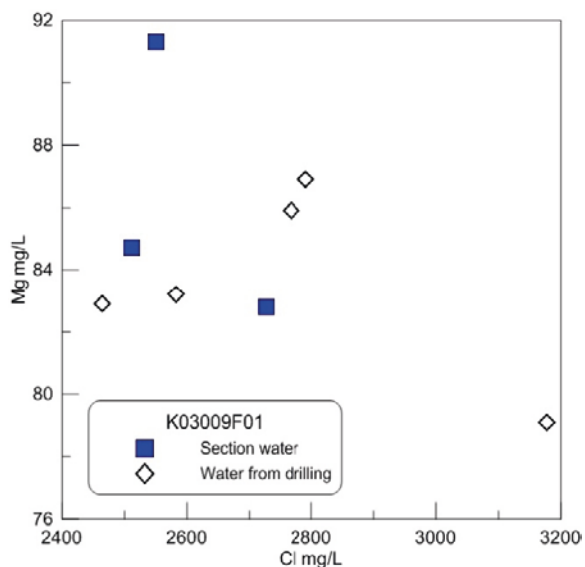

Figure 6-12. Mg plotted versus Cl for the sampled section waters and the waters sampled during drilling.

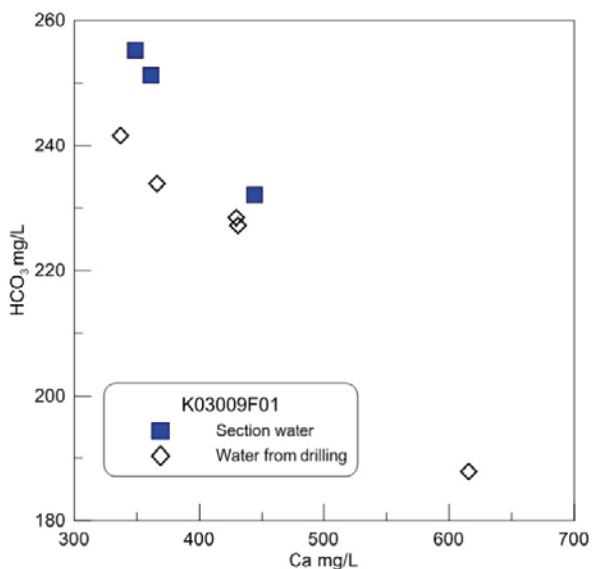

Figure 6-13. HCO₃ plotted versus Ca for the sampled section waters and the water sampled during drilling.

6.2.2 Isotopes

The $\delta^{13}\text{C}$ of the dissolved bicarbonate show very homogeneous values between -12.6 to -12.9 ‰ (PDB), cf. Figure 6-15. These uniform $\delta^{13}\text{C}$ values suggest that there is an inorganic carbon source, presumably a contribution from calcite dissolution.

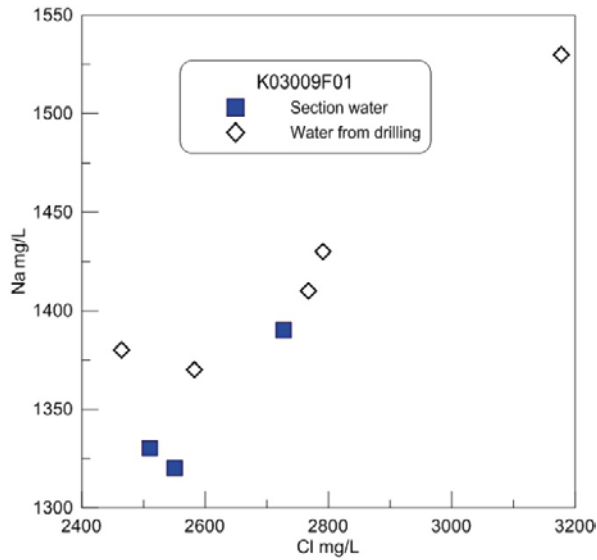

Figure 6-14. Na plotted versus Cl for the sampled section waters and the water sampled during drilling.

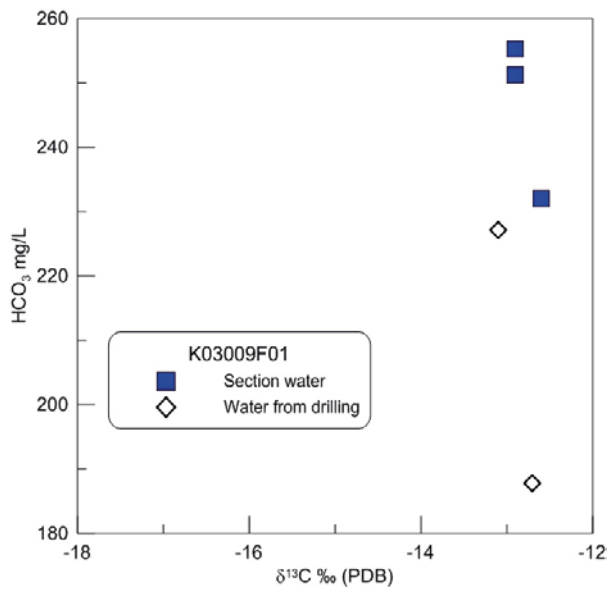

Figure 6-15. HCO₃ plotted versus δ¹³C in the dissolved bicarbonate for the sampled section waters and the waters sampled during drilling.

The sulphur isotopes are relatively high with numbers between +29.9 and 30.9 ‰ (CDT), cf. Figure 6-16. These are considerably higher values than seen in the K08028F01 section waters and are consistent with a sulphate reduction process in these waters. The fact that ¹³C does not show typical organic signatures in the bicarbonate, is most likely due to input from an inorganic carbon source, presumably from calcite dissolution.

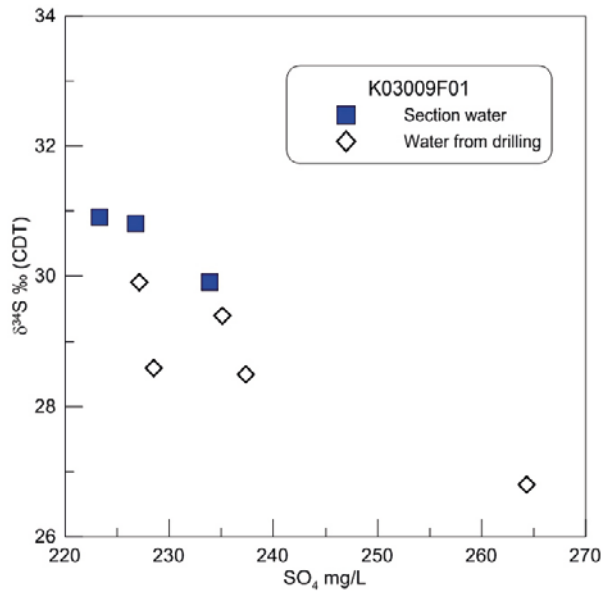

Figure 6-16. $\delta^{34}S$ plotted versus SO_4 for the sampled section waters and the waters sampled during drilling.

7 Comparison of hydrogeochemical data from boreholes K08028F01 and K03009F01

There are clear differences between the water types seen in the two boreholes. The data from borehole K08028F01 show a wide variation in the concentrations of the dissolved components, as seen in the three sampled sections. In contrast, the waters sampled from borehole K03009F01 are more homogeneous and display a smaller variation in the concentrations of the dissolved ions.

Prior to the discussion on and comparison between the hydrogeochemistry of the two boreholes it is noted that not all differences in the hydrogeochemistry are reflecting the origin of the water. Some parameters, such as Ca and HCO_3 in borehole K03009F01, may have been affected by the grouting performed in the borehole. As can be seen in Figure 7-1 slightly elevated Ca concentrations can be found in borehole K03009F01. According to the drilling report, grouting was made in the initial part of the borehole, between about 2.5 m into 15.5 m in the borehole (Nilsson 2016). The Ca and HCO_3 values from the drilling water as well as from the section water deeper in the borehole do not show any elevated concentration resulting from the grouting. Hence, there is no evident impact on the groundwater. This is also supported by the pH values which show no sign of elevation.

In the plots of $\delta^2\text{H}$ versus $\delta^{18}\text{O}$ for waters the two boreholes show a clear difference in the isotope signatures. Both water types project below the GMWL line, cf. Figure 7-2, and show indications of a slight deuterium excess in comparison with the GMWL line (Clark and Fritz 1997). What is interesting to note is that the data from the water sampled during drilling lies relatively close to the GMWL. The reason for this is hard to explain, but is most likely due to the fact that this isotope signature represent another water source than the samples from the packed-off sections.

The plot of Sr versus Ca in Figure 7-3 shows a very nice linear relationship between the elements. As can be seen the strong linear relationship in K08028F01 borehole waters is supporting binary mixing/dilution scenario proposed in the discussion in Section 6.1. A similar linear relationship is developed for the K03009F01 samples as well, although not as perfect as for borehole K08028F01.

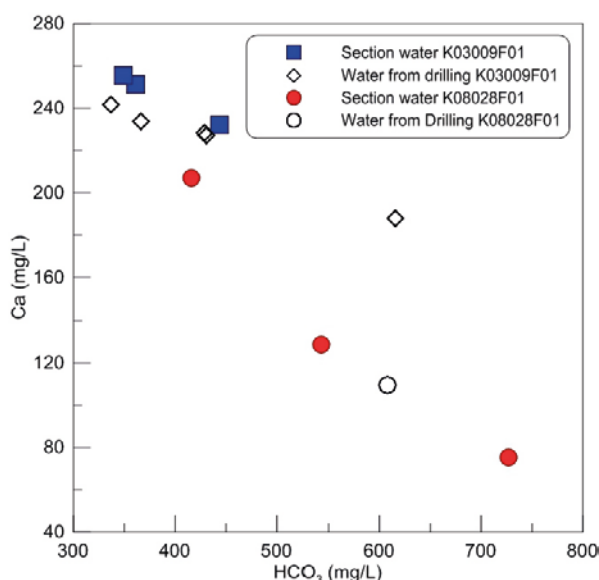

Figure 7-1. Ca plotted versus HCO_3 for data from boreholes K08028F01 and K03009F01.

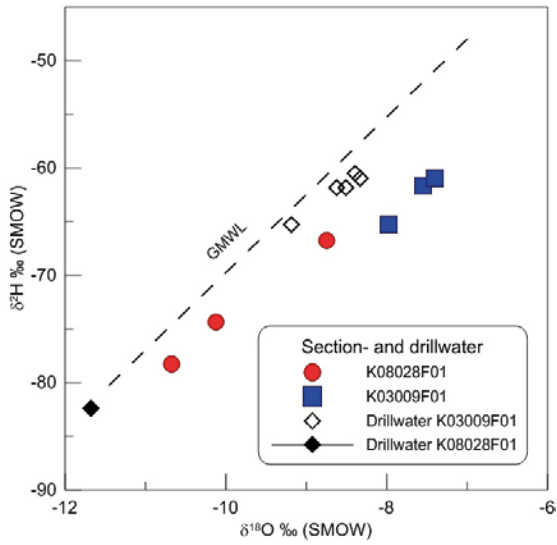

Figure 7-2. δ^2H plotted versus $\delta^{18}O$ for the sampled section waters and the waters sampled during drilling.

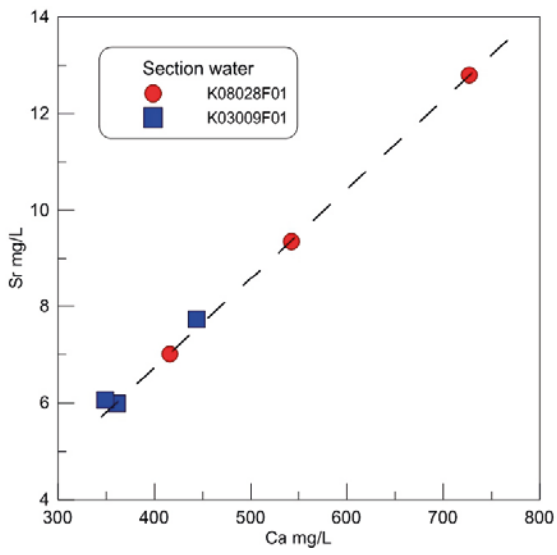

Figure 7-3. Sr plotted versus Ca for the sampled section waters.

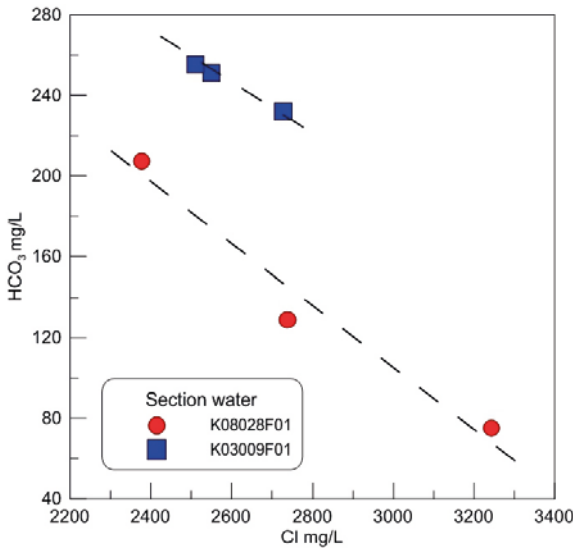

Figure 7-4. HCO_3 plotted versus Cl for the sampled section waters.

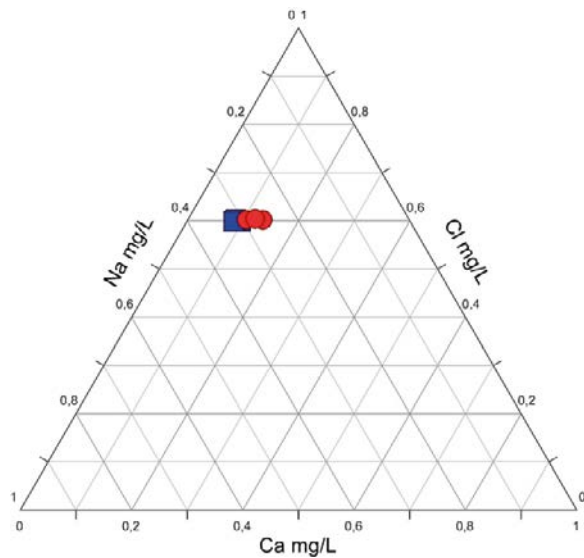

Figure 7-5. Piper plot showing the relationship between Na, Ca and Cl for the section waters from both boreholes.

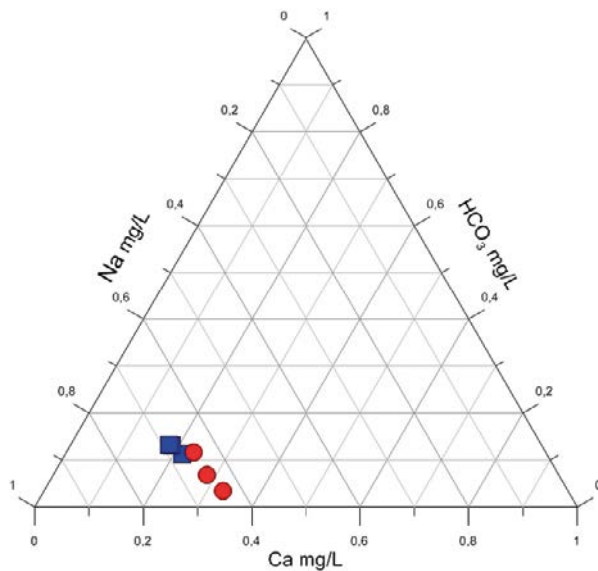

Figure 7-6. Piper plot showing the relationship between Na, Ca and HCO₃ in the section waters from both boreholes.

The linearity between the major elements is evident also in the plot of HCO₃ versus Cl in Figure 7-4 and Ca versus Na in Figure 7-7. The elevated HCO₃ seen in the section water from borehole K03009F01 may be a result from contribution of bicarbonate from the grouting in that borehole.

In order to demonstrate the similarities between the two sets of section waters two piper plots are made with the elements Na-Ca-Cl and Na-Ca-HCO₃. As seen in Figure 7-5 both water types plot high up in the triangle which is consistent with a deeper saline component.

One way to differentiate between a marine and a deep saline component of the sampled water is to plot Ca/Mg versus Br/Cl (Frape et al. 1984). As can be seen in Figure 7-8 the ratios of these elements in the section waters from K08028F01 tend to move towards higher ratios, indicating a deep saline component. In contrast, the values from the section waters in K03009F01 are significantly lower, suggesting a tendency towards a marine component.

Two groupings develop in the plot of HCO₃ versus $\delta^{13}\text{C}$ as seen in the Figure 7-9. The homogeneous values in the section waters of K03009F01 support a uniform inorganic carbon source, whereas the more negative $\delta^{13}\text{C}$ values of the K08028F01 section waters show more in-mixed organic carbon.

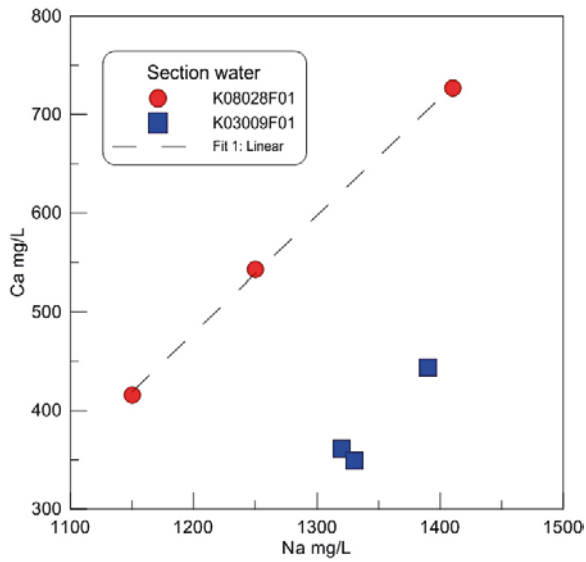

Figure 7-7. Ca plotted versus Na for the section waters and the waters from drilling.

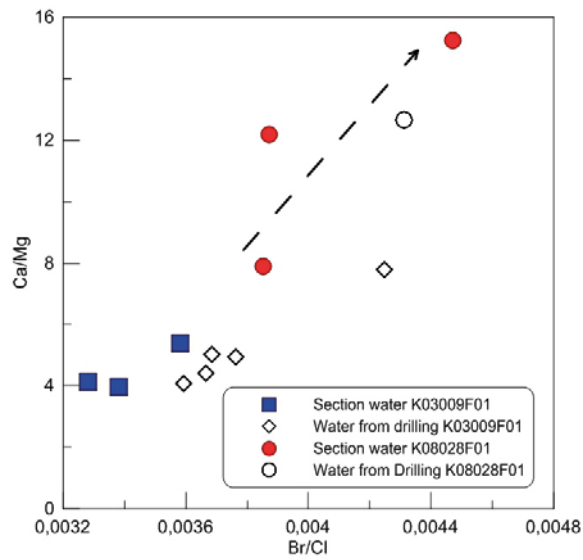

Figure 7-8. Ca/Mg plotted versus Br/Cl for the section waters and the waters from drilling.

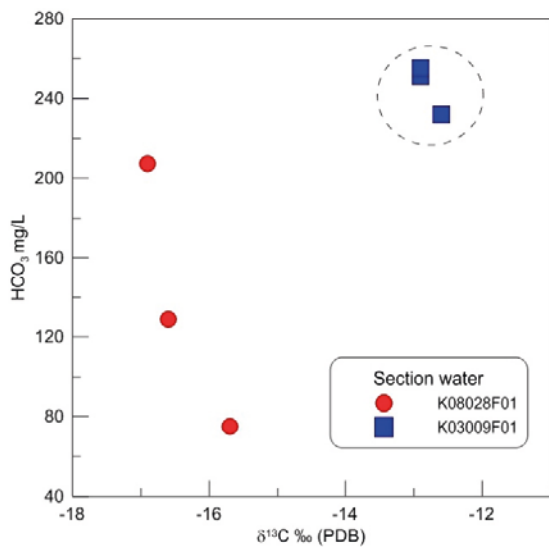

Figure 7-9. HCO_3^- plotted versus $\delta^{13}\text{C}$ in the dissolved bicarbonate for the sampled section waters from both boreholes.

The comparison between $\delta^{34}\text{S}$ values for the two boreholes, as seen in Figure 7-10, there are higher $\delta^{34}\text{S}$ values in K08028F01 compared to K03009F01. This is most likely a result of a more developed sulphate reduction that has been taking place in the waters sampled by borehole K08028F01. The relatively high ^{13}C values are not consistent with such a process, and therefore most likely reflect an inorganic carbon source, presumably from grouting of K03009F01, as mentioned earlier in the report.

The strontium isotopes show a total variation between 0.71 and 0.72 in all waters sampled from the packed-off sections. This implies typical formation water and the $^{87}\text{Sr}/^{86}\text{Sr}$ values are as expected (Peterman and Wallin 1999). These values are compatible with typical numbers reported earlier from Äspö (Peterman and Wallin 1999, Laaksoharju et al. 2009). In the plot of $^{87}\text{Sr}/^{86}\text{Sr}$ versus the concentration of Sr, a uniform pattern appears along the vertical line (Figure 7-11). However, in Figure 7-12, where the same data are plotted with a higher resolution, a different pattern emerges. The groundwater data from borehole K08028F01 show a little variation in $^{87}\text{Sr}/^{86}\text{Sr}$ with the variation in Sr concentration. In contrast the data from borehole K03009F01 show a larger variation in $^{87}\text{Sr}/^{86}\text{Sr}$, but a small variation in Sr concentration.

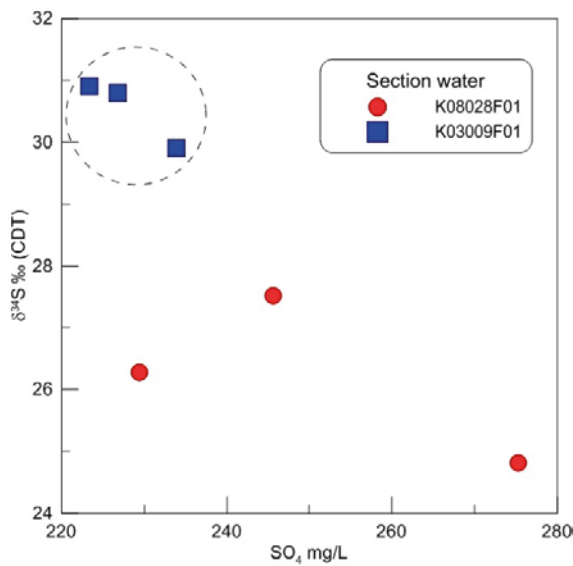

Figure 7-10. $\delta^{34}\text{S}$ plotted versus SO_4 for the sampled section waters from both boreholes.

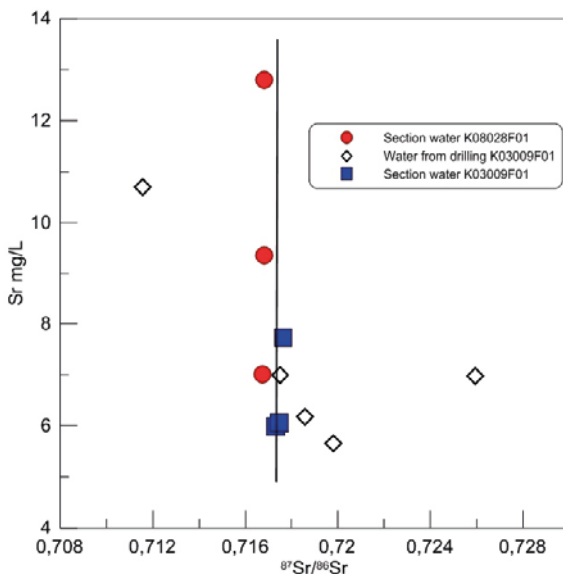

Figure 7-11. Sr plotted versus $^{87}\text{Sr}/^{86}\text{Sr}$ in the section waters together with the waters from drilling.

The relatively higher Sr concentrations as well as $^{87}\text{Sr}/^{86}\text{Sr}$ values seen in the K08028F01 waters compared to K03009F01 suggest that there is a contribution of less radiogenic strontium from calcite dissolution in borehole K08028F01.

Finally, a plot of $\delta^{18}\text{O}$ versus $^{87}\text{Sr}/^{86}\text{Sr}$ (Figure 7-13) also clearly delineates the differences between the section waters sampled by the two boreholes.

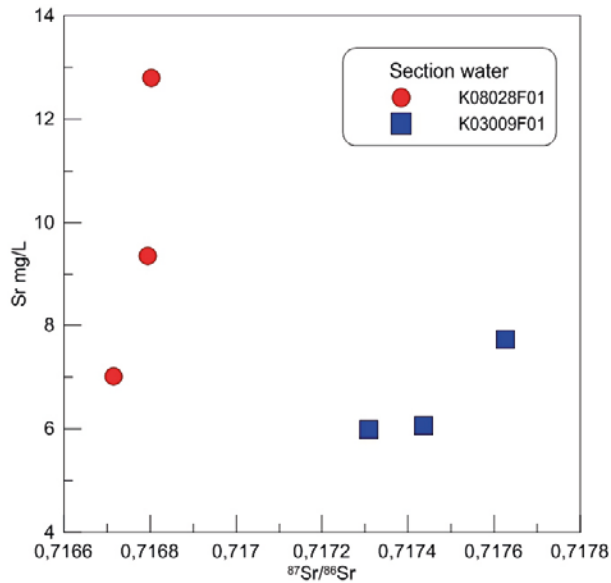

Figure 7-12. Sr plotted versus $^{87}\text{Sr}/^{86}\text{Sr}$ in the section waters. Larger resolution than employed in the plot in Figure 7-11.

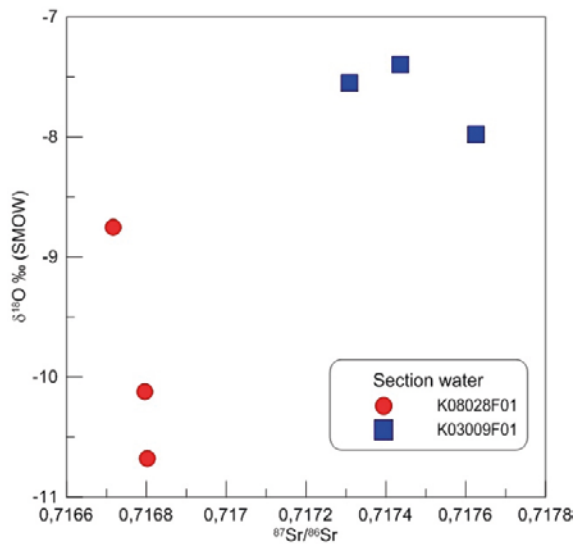

Figure 7-13. $\delta^{18}\text{O}$ plotted versus $^{87}\text{Sr}/^{86}\text{Sr}$ for the sampled section waters from both boreholes.

8 Conclusions

The general observations made on the basis of the analysed water samples reveal that there is a significant variation in the dissolved elements of the groundwater between the sampled sections of the two boreholes. The data can be used to confirm and/or support other geochemical/geological/hydrogeological observations and interpretations.

The overall results show that the hydrogeochemical data collected during drilling roughly mimic the pattern subsequently obtained from the packed-off section waters. This is clear when comparing the dissolved components, however, one has to be careful when interpreting the stable isotopes signatures between the two sampling methods. The difference in isotope signature between the drilling water and groundwater is quite evident from this fact. In conclusion, the hydrogeochemistry from the drilling water gives a good estimate of the distribution of the major elements of the water residing in the rock fractures in conjunction with the two boreholes. However, one has to be aware of the fact that the chemical pattern from drilling water is an average of all waters collected up to the specific borehole length, whereas the section water is a fingerprint of a selected fracture system sampled by the packed-off section.

The hydrogeochemistry of borehole K08028F01:

- The conservative parameters Cl and $\delta^{18}\text{O}$ display a typical mixing pattern.
- The variation in concentration of the dissolved components between the sections could also be an indication a progressive dilution of one water type.
- The dissolved components of the groundwater in the sections have a deep saline component.
- The carbonate system suggests that there exists, or has existed, calcite dissolution. The carbon source is interpreted as being a mixture of an inorganic and organic carbon.

The hydrogeochemistry of borehole K03009F01:

- The waters sampled from the packed-off sections show very homogeneous characteristics.
- The $\delta^{18}\text{O}$ values of the water imply that there is an in-mixed component of marine water (Baltic seawater).
- The $\delta^{34}\text{S}$ values of the dissolved sulphate indicate that there has been a sulphate reduction process in the water.

Piper plots show that the overall characteristics of the waters are not that overly different, however the $^{87}\text{Sr}/^{86}\text{Sr}$ isotopes clearly delineate differences between the waters sampled from the two boreholes.

References

SKB's (Svensk Kärnbränslehantering AB) publications can be found at www.skb.com/publications.

- Clark I D, Fritz P, 1997.** Environmental isotopes in hydrogeology. Boca Raton, FL: Lewis Publishers.
- Frape S K, Fritz P, McNutt R H, 1984.** Water–rock interaction and chemistry of groundwaters from the Canadian Shield. *Geochimica et Cosmochimica Acta* 48, 1617–1627.
- Hjerne C, Ragvald J, Palmfjord E, 2016.** KBS3H project/DETUM Large fractures. Hydraulic interference tests in boreholes K03009F01 and K08028F01. SKB P-15-04, Svensk Kärnbränslehantering AB.
- Laaksoharju M, Tullborg E-L, Wikberg P, Wallin B, Smellie J, 1999.** Hydrogeochemical conditions and evolution at the Äspö HRL, Sweden. *Applied Geochemistry* 14, 835–859.
- Laaksoharju M, Smellie J, Tullborg E-L, Gimeno M, J Molinero, Gurban I, Hallbeck L, 2008.** Hydrochemical evaluation and modeling performed within the Swedish site investigation programme. *Applied Geochemistry* 23, 1761–1795.
- Laaksoharju M, Smellie J, Tullborg E-L, Wallin B, Drake H, Gascoyne M, Gimeno M, Gurban I, Hallbeck L, J. Molinero J, Nilsson A-C, Waber N, 2009.** Bedrock hydrochemistry Laxemar. SKB R-08-93, Svensk Kärnbränslehantering AB.
- Nilsson G, 2016.** KBS-3H – DETUM. Steered core drilling of boreholes K03009F01 and K08028F01 at the Äspö HRL. SKB P-15-11, Svensk Kärnbränslehantering AB.
- Peterman Z E, Wallin B, 1999.** Synopsis of strontium isotope variations in groundwater at Äspö, southern Sweden. *Applied Geochemistry* 14, 939–951.
- Wallin B, Laaksoharju M, Tullborg E-L, 2007.** Description of the different end-members identified from interpretations of groundwater chemistry and mixing models; results from Äspö and Laxemar area. In Svensson U (ed), Vidstrand P, Neretnieks I, Wallin B, 2008. Towards a new generation of flow and transport models for the Äspö Hard Rock Laboratory. Main results from the project Äspömodels 2005. SKB R-08-74, Svensk Kärnbränslehantering AB.

Tabulations of major element composition, isotopes, pH, conductivity, PmC and uranine concentrations of sampled groundwaters.

Table A-1. Major element composition of groundwaters sampled in boreholes K08028F01 and K03009F01.

IDCODE	Date	WC_SEC (m)	NA (mg/l)	K (mg/l)	CA (mg/l)	MG (mg/l)	HCO3 (mg/l)	CL (mg/l)	SO4 (mg/l)	SO4_S (mg/l)	BR (mg/l)	F (mg/l)	SI (mg/l)	FE (mg/l)	FETOT (mg/l)	FEII (mg/l)	MN (mg/l)	LI (mg/l)	SR (mg/l)
Drilling																			
K03009F01	2013-11-12	1.44	1530.0	16.60	616.0	79.10	187.80	3178.0	264.30	91.40	13500	1.82	7.67	0.7510	0.790	0.790	0.38500	0.4470	10700
K03009F01	2013-11-27	5.41	1430.0	17.10	429.0	86.90	228.40	2791.0	237.40	80.80	10500	1.63	7.11	0.9740			0.45400	0.2580	6980
K03009F01	2013-11-29	7.75	1410.0	16.60	431.0	85.90	227.20	2768.0	228.50	79.90	10200	1.65	6.48	1.2800	0.710	0.710	0.45100	0.2520	6990
K03009F01	2013-12-05	13.11	1380.0	21.00	337.0	82.90	241.60	2464.0	227.10	77.20	8850	1.66	6.16	0.4780			0.43200	0.1830	5660
K03009F01	2013-12-08	31.12	1370.0	17.20	366.0	83.20	233.90	2582.0	235.10	77.50	9460	1.73	6.50	0.5880			0.43700	0.2040	6180
Section water																			
K03009F01	2014-02-25	26.70	1390.0	17.00	444.0	82.80	232.00	2727.0	233.90	92.80	9770	1.56	6.99	0.6430	0.630	0.640	0.42100	0.2320	7720
K03009F01	2014-02-27	18.70	1320.0	19.50	361.0	91.30	251.20	2550.0	226.80	90.60	8620	1.71	7.02	0.6690	0.630	0.630	0.43900	0.1610	5980
K03009F01	2014-03-03	15.70	1330.0	18.50	349.0	84.70	255.30	2511.0	223.30	90.10	8240	1.76	7.32	0.5450	0.530	0.530	0.38500	0.1540	6060
Drilling																			
K08028F01	2014-06-10	34.52	1320.0	5.44	608.0	48.00	109.40	2992.0	246.40	97.10	12900	1.20	7.86	0.2460			0.26600	0.4570	10700
Section water																			
K08028F01	2014-10-07	31.00	1410	5.18	727	47.7	75.3	3243	275.3	93.3	14.5	1.26	7.18	0.17	0.17	0.16	0.306	0.497	12.8
K08028F01	2014-10-09	38.00	1150	5.21	416	52.7	207.2	2378	245.6	82.9	9.16	1.3	8.4	0.126	0.13	0.12	0.278	0.197	7.02
K08028F01	2014-10-27	24.00	1250	4.98	543	44.6	128.9	2739	229.4	86.3	10.6	1.22	8.19	0.051			0.24	0.33	9.35

Table A-2. Isotopes, pH, conductivity, PmC and uranine concentrations of waters sampled in boreholes K08028F01 and K03009F01.

IDCODE	Date	SECMID (m)	PH (pH unit)	COND (mS/m)	URANINE (µg/l)	DOC (mg/l)	PmC (pmc)	C13 (PDB)	AGE_BP (year)	S34_SO4 (CDT)	CL37 (SMOC)	SR87 (ratio)	2H (SMOW)	TR (TU)	O18 (SMOW)	PH_F (pH unit)	EC_F (mS/m)	
Drilling																		
K03009F01	2013-11-12	1.44	7.62	1041.0	1.10	5.8	79.40	-12.70	1792	26.8	0.19	0.711563	-65.3	5.20	-9.19	7.59	1043.0	
K03009F01	2013-11-27	5.41	7.77	890.0	4.10					28.5		0.725939	-61.8	6.00	-8.62	7.67	839.0	
K03009F01	2013-11-29	7.75	7.54	886.0	1.00	6.8	80.10	-13.10	1725	28.6	0.18	0.717477	-61.8	5.50	-8.51	7.58	882.5	
K03009F01	2013-12-05	13.11	8.26	824.0	0.80					29.9		0.719819	-60.5	6.60	-8.39	8.22	765.0	
K03009F01	2013-12-08	31.12	7.84	832.0	2.70					29.4		0.718579	-61.0	5.60	-8.33	7.73	792.0	
Section water																		
K03009F01	2014-02-25	26.70	7.57	878.0	1.10	7.1	80.60	-12.60	1665	29.9	0.10	0.717626	-65.3	6.80	-7.98	7.51	865.0	
K03009F01	2014-02-27	18.70	7.55	823.0	1.10	7.4	82.00	-12.90	1535	30.8	0.09	0.717309	-61.7	5.90	-7.55	7.52	818.0	
K03009F01	2014-03-03	15.70	7.64	819.0	1.10	7.6	82.20	-12.90	1510	30.9	0.07	0.717436	-61.0	5.90	-7.40	7.55	807.0	
Drilling																		
K08028F01	2014-06-10	34.52	7.73	931.0	0.70					26.0			-82.4	5.00	-11.68	7.59	927.0	
Section water																		
K08028F01	2014-10-07	31.00	7.67	1007	0.3	4.2	69.3	-15.7	2879	24.81	-0.06	0.716803	-78.29	3.5	-10.68	7.6	995	
K08028F01	2014-10-09	38.00	7.7	774	0.6	7.6	80.6	-16.9	1674	27.51	-0.05	0.716716	-66.75	6.4	-8.75	7.58	775	
K08028F01	2014-10-27	24.00	7.71	871	0.3	5.9	77	-16.6	2034	26.28	0.06	0.716795	-74.34	4.2	-10.12	7.01	877	

