

P-14-11

Basic engineering of buffer production system

Peter Eriksson
Svensk Kärnbränslehantering AB

November 2014

Svensk Kärnbränslehantering AB
Swedish Nuclear Fuel
and Waste Management Co
Box 250, SE-101 24 Stockholm
Phone +46 8 459 84 00



ISSN 1651-4416

SKB P-14-11

ID 1434049

Basic engineering of buffer production system

Peter Eriksson
Svensk Kärnbränslehantering AB

November 2014

Keywords: KBP1002, Buffer production, Block, Compaction.

Data in SKB's database can be changed for different reasons. Minor changes in SKB's database will not necessarily result in a revised report. Data revisions may also be presented as supplements, available at www.skb.se.

A pdf version of this document can be downloaded from www.skb.se.

Abstract

A description of the production process for buffer components has been done. This description is based on experiences gained at test production up till this date.

For the production of buffer block two methods are considered, uni-axial compaction and isostatic. In uni-axial compaction the blocks are compacted from one direction and in isostatic compaction the block is submerged into a high pressure fluid in rubber bag. Both methods are considered to be able to produce blocks that fulfil the requirements. The study suggests that the required daily production can be done in less than 8 hours.

There has also been some development in the technology for uni-axial compression. A new type of mould with a split liner has been designed and tested in small scale. Furthermore the effect of lubricants have been investigated and it is believed that the blocks could be compacted without lubricants. The new mould type together with removal of lubricants would lead to a huge improvement due to the fact that this mould can produce completely cylindrical blocks. Machining of the blocks could almost be eliminated.

Sammanfattning

En beskrivning av produktionsprocessen för buffertkomponenter har tagits fram. Denna processbeskrivning är baserad på de försök och tester som hittills har gjorts.

Det finns två möjliga tekniker för att producera buffertblock, enaxlig kompaktering och isostatisk kompaktering. Vid enaxlig pressning så kompakteras blocken från en riktning medan vid isostatpressning så kompakteras blocken från alla riktningar genom att materialet läggs i en tät säck som sänks ner i en vätska som sedan trycksätts. Båda teknikerna bedöms kunna producera block som uppfyller kraven. Utredningar tyder också på att de tänkta mängderna block som behövs kan produceras på 8 timmar oberoende av vilken kompakteringsteknik som väljs.

Tekniken för att kompaktera block med enaxlig pressning har även vidareutvecklats och en ny typ av form med ett delbart foder har designats och testats i liten skala. Även smörjmedlets inverkan vid pressning har studerats och det är troligt att block kan pressas utan smörjmedel. Den nya formdesignen tillsammans med avskaffande av smörjmedel skulle innebära stora fördelar på grund av att helt cylindriska block skulle kunna produceras. Bearbetning av blocken skulle därigenom nästan helt kunna undvikas.

Contents

| | | |
|-------------------|--|----|
| 1 | Introduction | 7 |
| 1.1 | Production Process | 7 |
| 2 | Objective and scope | 9 |
| 3 | Assumptions and requirements | 11 |
| 4 | Components to be produced | 13 |
| 5 | Process description | 15 |
| 5.1 | General | 15 |
| 5.2 | Storage | 15 |
| 5.3 | Crushing and drying | 15 |
| 5.4 | Silos | 16 |
| 5.5 | Mixing | 16 |
| 5.6 | Uni-axial compaction | 16 |
| | 5.6.1 Mould Filling Station | 17 |
| | 5.6.2 Compaction | 18 |
| | 5.6.3 De-moulding and mould cleaning | 18 |
| | 5.6.4 Maintenance area | 19 |
| 5.7 | Isostatic compaction | 19 |
| | 5.7.1 Filling | 20 |
| | 5.7.2 Pressing | 21 |
| | 5.7.3 Maintenance area | 21 |
| 5.8 | Inspection and control | 21 |
| 5.9 | Intermediate storage | 22 |
| 5.10 | Machining | 22 |
| 5.11 | Pellet pressing | 23 |
| | 5.11.1 Roller Compaction | 23 |
| | 5.11.2 Extruded pellets | 23 |
| 6 | Capacity | 25 |
| 7 | Complementary tests | 27 |
| 7.1 | Lubrication | 27 |
| | 7.1.1 Performed tests | 27 |
| | 7.1.2 The compaction process | 27 |
| | 7.1.3 Complications | 29 |
| | 7.1.4 Measurements | 29 |
| | 7.1.5 General results | 29 |
| | 7.1.6 Calculated data | 29 |
| | 7.1.7 Discussion | 32 |
| 7.2 | Swelling after compaction | 36 |
| 7.3 | Cylindrical mould | 37 |
| | References | 41 |
| Appendix 1 | Preliminary cycle diagram uni-axial press | 43 |
| Appendix 2 | Preliminary cycle diagram cold isostatic press | 45 |
| Appendix 3 | Preliminary specification uni-axial press | 47 |
| Appendix 4 | Preliminary specification isostatic press | 51 |
| Appendix 5 | Data test with cylindrical mould | 55 |

1 Introduction

SKB's reference method for final repository of spent nuclear fuel is the KBS-3 method where the nuclear fuel is placed in copper canisters 500 meters down in the bedrock surrounded by swelling clay. This clay, a bentonite clay, is installed in the form of compacted buffer blocks, backfill blocks and pellets as seen in Figure 1-1.

This report will cover the production of buffer blocks and pellets and will present how these components can be produced and what equipment that would be needed for this production.

1.1 Production Process

The raw material used in the buffer production process is a bentonite clay, mined in open pit mines. The raw material is after mining transported to the processing plant where it is coarsely crushed and sun dried in fields to reduce the water content from 30–35% down to a moisture content of 20 to 23%. Stockpiled bentonite may also be blended with other grades of bentonite to produce a uniform material. Next, the bentonite is dried in rotary or fluid bed dryers fired with natural gas, oil, or coal to reduce the moisture content to customer requirement.

Quality control is performed continuously during the described production process.

The bentonite is then transported by bulk ships to the harbour of Hargshamn in Sweden where the material is unloaded into large storage buildings and delivery control is performed. The bentonite is then crushed to the correct granule size distribution and dried, if needed before being placed in silos. The bentonite cannot have too high water content because it might stick in the storage and transportation system.

Transportation of the raw material to the production facility is done using bulk trucks which are unloaded pneumatically or by a conveyor system into storage silos within the production facility. In the production building the bentonite is mixed with water to get the correct water content before compression and machining to the desired components.

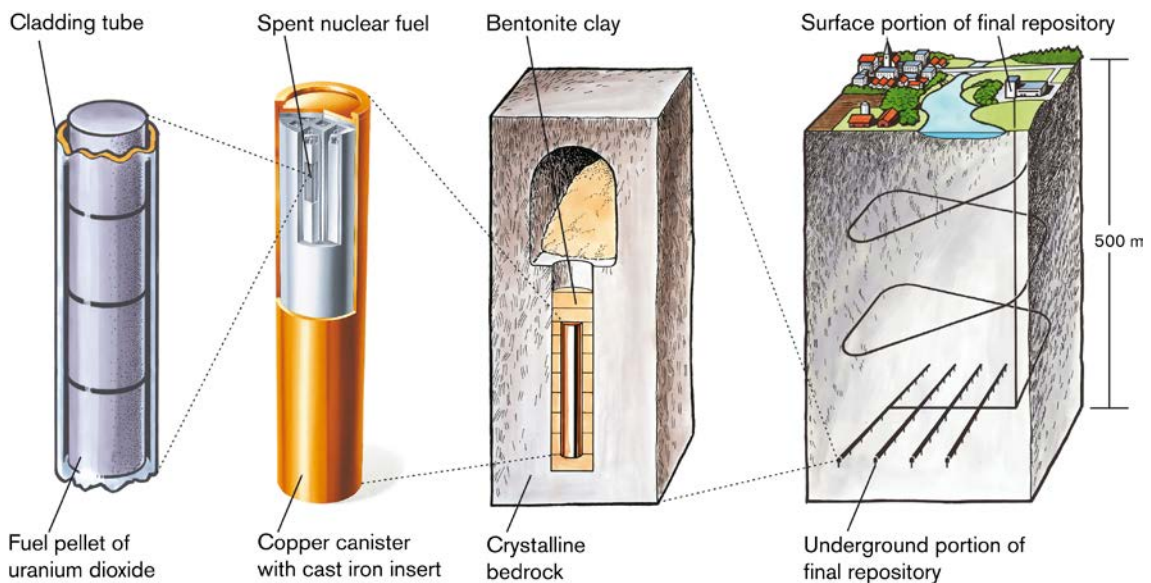

Figure 1-1. The barriers in the planned repository.

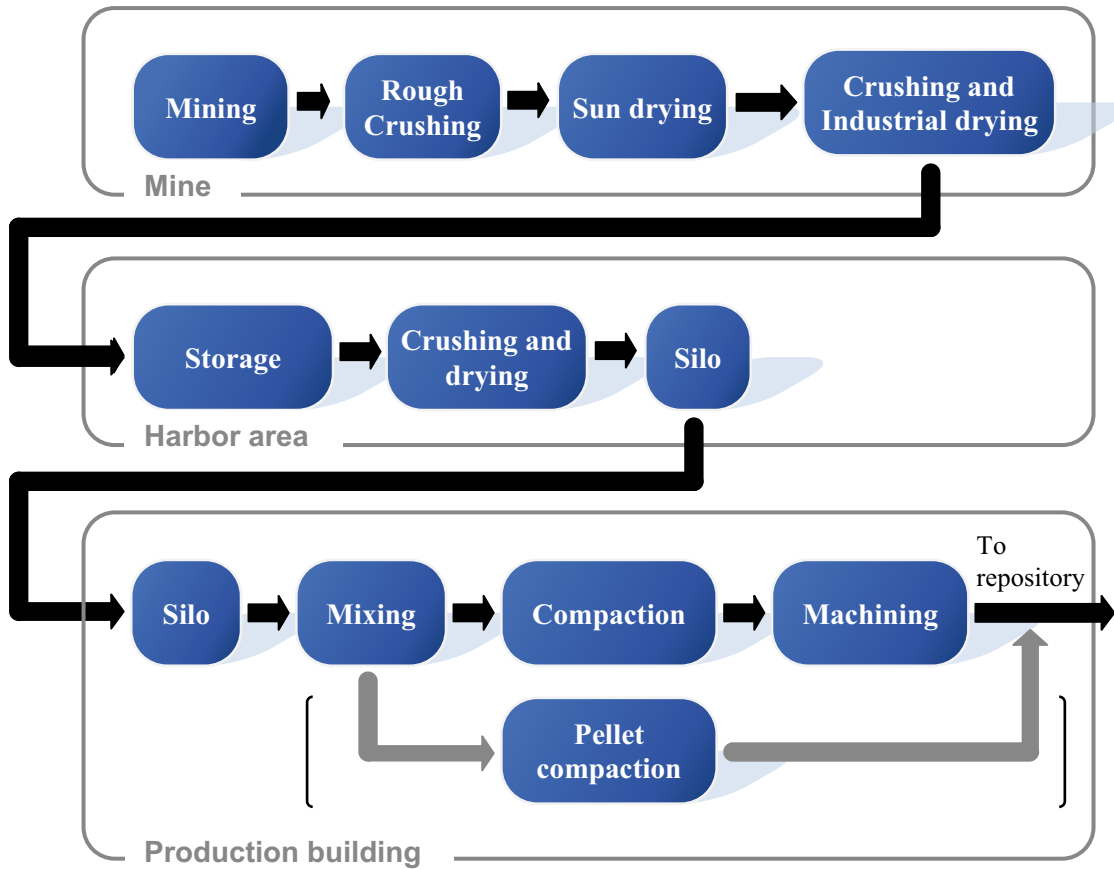

Figure 1-2. Process steps from mining to finished bentonite products.

2 Objective and scope

This report covers the production chain for the harbour area and production building in accordance with Figure 1-2 for both isostatic compaction and uni-axial compaction.

A suggestion of equipment needed for production of buffer components with sufficient capacity and quality is made based on the experiences gained during previous buffer production. In addition we present a process description and specifications for the different machines covering both isostatic compaction and uni-axial compaction.

The process description and specification have then been used to estimate the investment cost for the equipment and the production capacity.

3 Assumptions and requirements

This chapter will describe the assumptions made in this report and what requirements that has been used to design the production system.

Requirements for the production system:

- The production system needs to be able to produce components for 200 deposition holes per year, which is equal to 6 buffer rings and 6 solid buffer blocks and 2 tons of pellets per day.
- The material should be possible to transport pneumatically into the production building.
- The production system needs to be able to produce components according to the specification in Chapter 4. The production system needs to have the capability to produce components according to specification for different materials. Different materials have different compactibility but it is assumed that most material can be compacted with a pressure less than 100 MPa. 100 MPa is therefore set as a design parameter for the production equipment.
- The blocks need to be protected to ensure that they are not exposed to a relative humidity that differ from that in which the block are in equilibrium with the surrounding air. Equilibrium point for the relative humidity is approximately 75% for a block with 17% water content.

The following assumptions are made throughout the report:

- That the raw material used is a bentonite clay which fulfils the material specifications in SKB (2010).
- The raw material will be delivered from the mine in self-unloading bulk carriers to Hargshamn where it will be milled and possibly dried.
- Full-scale uni-axial compaction can be performed using a cylindrical mould. This has not been tested in full scale. However a number of scale tests, see Chapter 8.3, and simulations (Börgesson and Hernelind 2014) indicate that this is possible. In contrast, most of the previously produced uni-axial compacted blocks have been produced in a conical mould to allow block removal require additional milling to achieve the correct geometry and for the removal of any lubricants used.
- Lubrication during compaction can be excluded. The reason for this assumption is discussed further in Chapter 8.1. If this assumptions turns out to be false the production can still be done with a conical mould, currently being used in test production. This will increase the amount of waste material.
- It is assumed that SKB can produce full-scale isostatic block. Scale tests have been performed where Posiva has produced a number of blocks in 70%-scale (Ritola and Pyy 2012). It is assumed that up-scaling can be done without any major problems.

4 Components to be produced

For the repository there are five different bentonite components for the buffer that need to be produced. These components are:

- (1) Bottom blocks which the canister is standing on.
- (2) Buffer rings that are located around the canister.
- (3) Top blocks placed on top of the canister.
- (4) Buffer blocks stacked on the top block.
- (5) Pellet filling that surrounds the buffer blocks.

Since all the blocks except the rings, have the same density and water content only two types of blocks needs to be compacted: Solid blocks and ring blocks. All the blocks in Figure 4-1 can then be machined out of the solid block and the ring block.

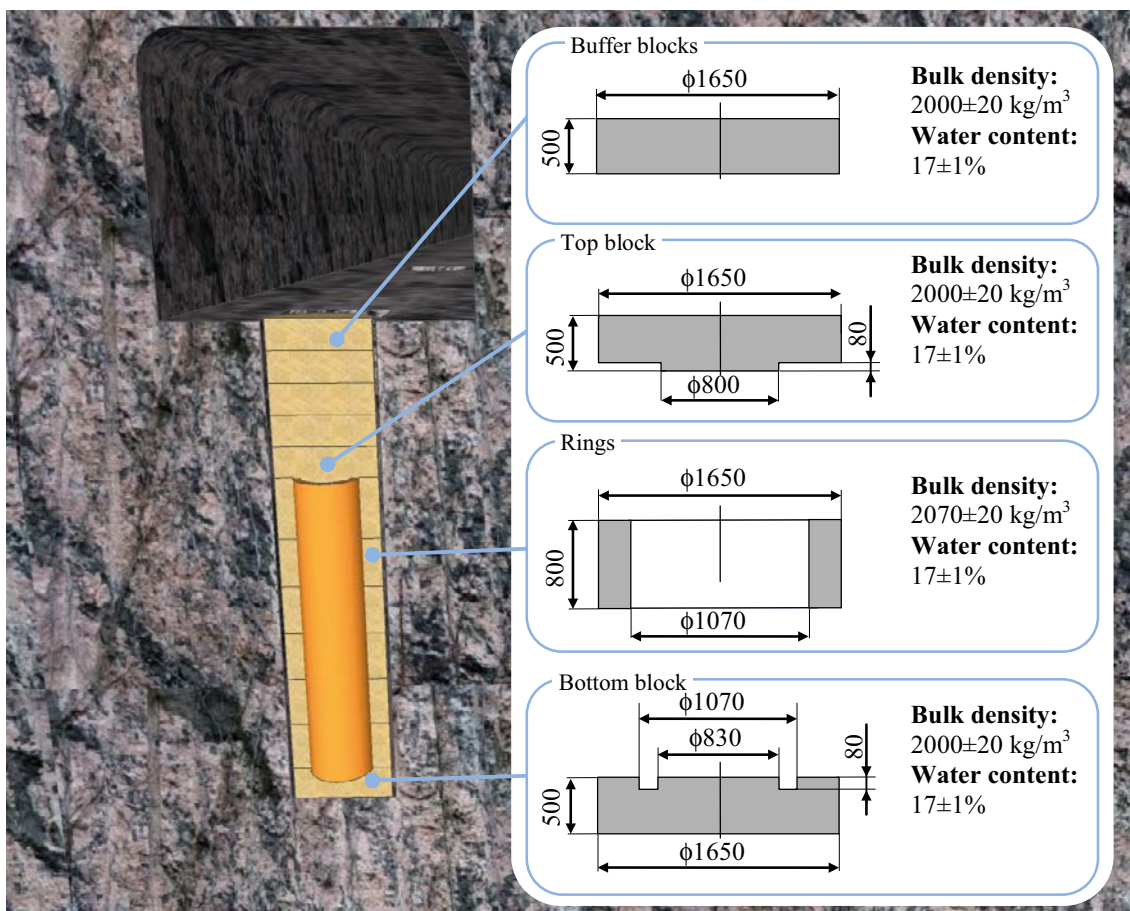

Figure 4-1. Illustration of the different block types needed.

5 Process description

5.1 General

It is possible to produce the required components using either isostatic- or uni-axial compaction. Therefore two different process descriptions have been developed covering production with both techniques. Both methods do however follow the general steps described in Figure 5-1.

5.2 Storage

The raw material is delivered by bulk ships and will initially be stored in storage buildings before being fed into the process. The capacity of the storage buildings should be dimensioned after the types of ships that are expected to be used for bentonite transport.

5.3 Crushing and drying

As the material is expected to be delivered as a coarsely grinded material and it needs to be milled to the correct granule size distribution. The current required granule size distribution is presented in SKB (2010). The milling and possibly drying needs to take place in the harbour area since the material shall be transported by bulk trucks and pneumatically blown into silos adjacent to the production building.

There will be a need for equipment for drying the raw material in the harbour area since the transportation by bulk trucks and storage in silos require the material to have a water content, water mass divided by dry mass, of less than 12%. This number is based on experiences from industries using bentonite and is lower than what is expected in the delivery.

Suitable equipment for drying and milling the material could be a pendulum mill also known as a Raymond mill. This equipment provides the possibility to use a heater to blow hot air through the milled bentonite and therefore drying it. The maximum temperature should be controlled so it does not exceed a limit were the bentonite will be affected. An example of equipment could be an EMO-3 from Molaris which has a drying and crushing capacity of at least 4-7 tonnes per hour.

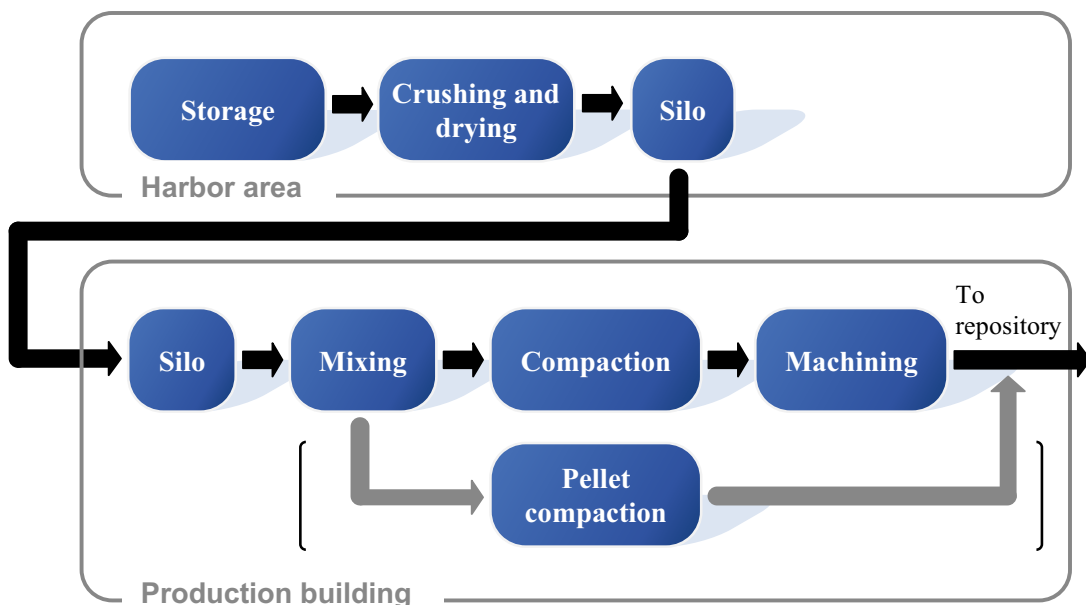

Figure 5 1. General description of the production system.

5.4 Silos

The crushed and dried raw material will be stored in silos both before transport to the production facility and within the production facility itself. It should be possible to load and unload the silos pneumatically.

5.5 Mixing

Before the material is ready for compaction water is added to get the correct water content. This is done in a mixer where clay material and water is mixed to achieve a water content of 17%. The mixer is then run until the batch has an even water content, which is estimated to be approximately 5 minutes. When the mixing is finished the material is transferred to a hopper underneath the mixer and transported to the filling station.

A mixer that has proved to work well for mixing bentonite during test production at the Äspö HRL is an intensive mixer from Eirich, Figure 5-2. A suitable model could be the RV-24, which will be able to mix approximately 1.6 tonnes per batch.

5.6 Uni-axial compaction

The uni-axial process is centred around a uni-axial press with a press force of 32,000 ton combined with a 3-position carousel. The production of uni-axial blocks will follow the process steps shown in Figure 5-3.

The blocks are compacted by applying a force from the top compressing the clay, which is placed in a rigid steel mould. It is also possible to have a moving piston in the bottom of the mould and compact the block from opposite directions. This would make it possible to compact higher blocks but it would also make the mould design more complicated.

The mould used in this description is comprised of a split cylindrical lining placed in a load-bearing cylinder, which is placed on a bottom plate, see Figure 5-4. The contact surface between the lining and the ring is tapered downwards/inwards to allow release of the lining by lifting it with hydraulic cylinders. This mould would be similar in design to the scale mould described in Section 8.3.

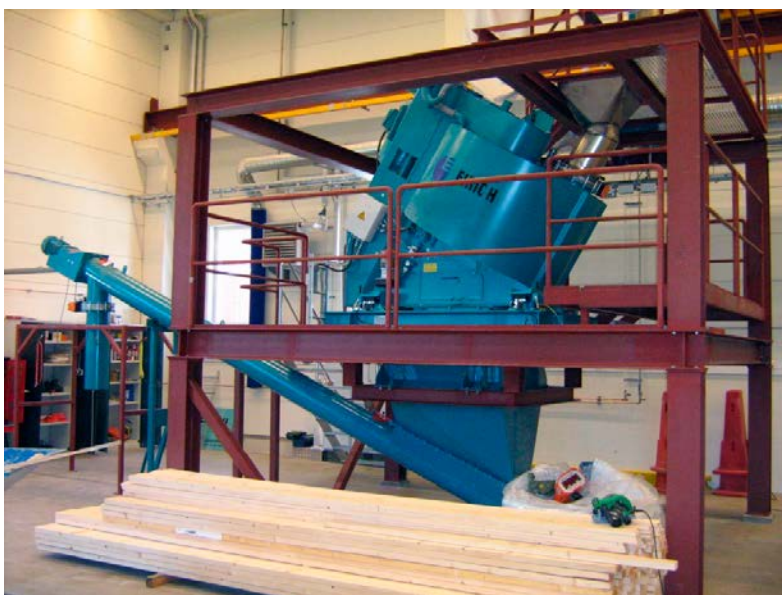

Figure 5-2. Eirich mixer used at Äspö.

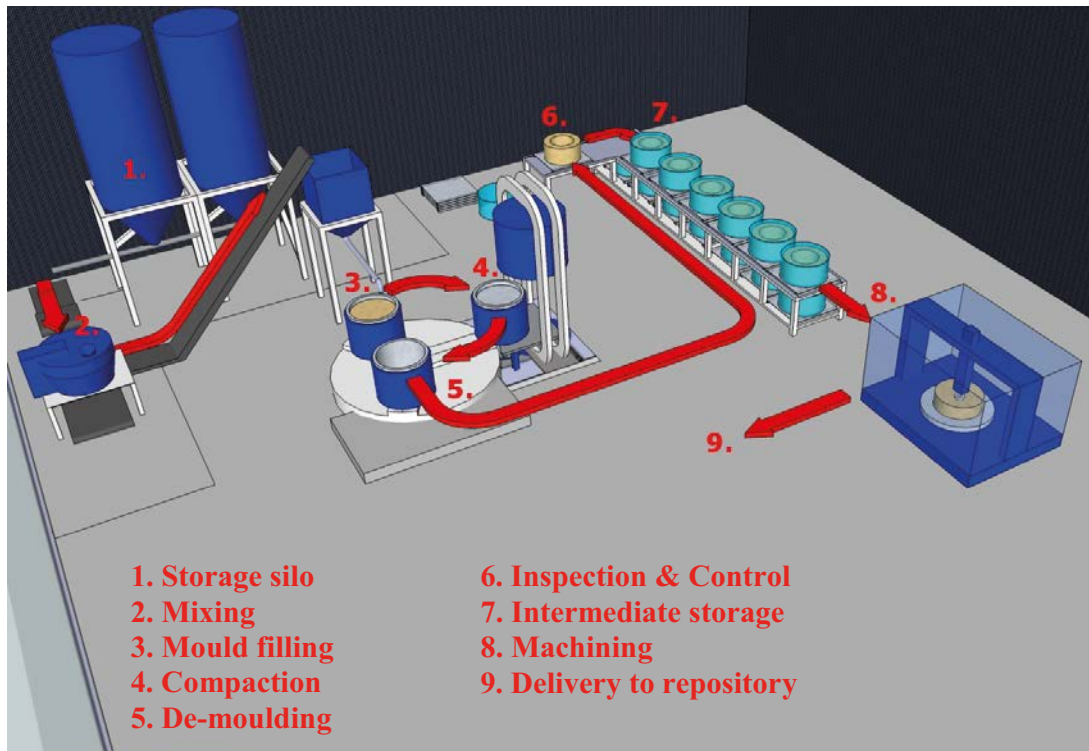

Figure 5-3. Illustration of block production with uni-axial compaction.

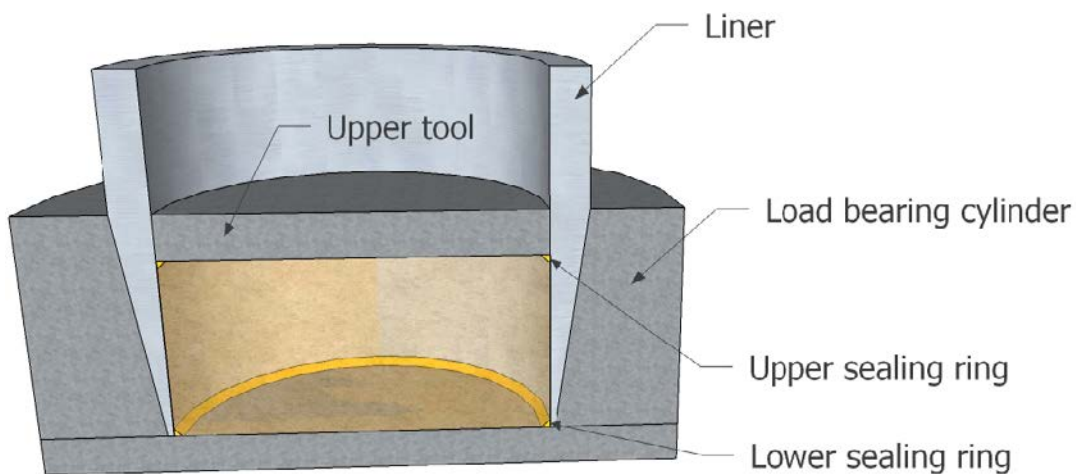

Figure 5-4. Cross section sketch of cylindrical mould describing tool parts.

5.6.1 Mould Filling Station

The first position (no. 3 in Figure 5-3) of the carousel is used for filling the assembled mould with bentonite. A filling device is located on a weighing station adjacent to the carousel. The correct weight of bentonite is poured into the filling device by a belt or screw conveyor from the mixing.

The filling device is positioned over the tool by hydraulics and mechanical guides. An internal filling arrangement is lowered into the tool and the bentonite is distributed from the bottom up.

After filling of the mould the top sealing ring will be mounted and a pre-vacuum device will be applied to the mould. This device consists of a hydraulically operated arm carrying a circular cover, which also acts as the upper tool, to be positioned on top of the bentonite filling in the mould and the air will be evacuated. The cover will remain on top of the bentonite surface in the press to ensure that no air leaks into the mould between the air evacuation and the compaction.

Vacuum will be created using an electric vacuum pump connected via an accumulator tank. A separation device will prevent bentonite from entering the vacuum system.

Spillage during filling and handling will be taken care of using a central vacuum unit with a system of pipes and flexible hoses in strategic locations.

5.6.2 Compaction

The newly filled mould will be placed in the press, which in this case is a uni-axial press with a press force of up to 32,000 tonnes, by rotating the carousel.

Equipment serving the press and various other installations on the factory floor such as hydraulic units, vacuum pumps, tanks, central vacuum units for waste management etc can preferably be placed in basement areas.

The compaction cycle will start as soon as the mould has been moved into the press. The upper part of the tool is fixed to the upper table of the press.

The press cycle starts with the upper tool moving down until the compaction of the bentonite begins. The pressure will be increased slowly until it reaches the specified compaction pressure. This loading step takes approximately 9 minutes.

After the initial loading the press is held at the specified compaction pressure for approximately 5 minutes before the unloading starts. It is important that these steps are not too fast since entrapped air must have time to leave the system otherwise the blocks risk cracking when the pressure is released. A preliminary cycle diagram can be found in Appendix 1.

5.6.3 De-moulding and mould cleaning

The carousel is then rotated once again and the mould is transferred to the station for block de-moulding. The cover plate is removed, the lining is loosened and the top sealing ring is removed.

The block is then lifted using a vacuum lifting device hanging from an overhead crane similar to the one used in current test production, see Figure 5-5. This crane covers the main fabrication area and the area for inspection. This crane is also used to transport the blocks to the inspection area.



Figure 5-5. Vacuum lifting tool during test production of buffer blocks.

Bottom sealing ring are then removed and the mould is rebuilt by:

1. Cleaning and installing the lining sections.
2. Cleaning and installing the sealing rings into the mould.

Any damaged parts are exchanged with parts that have been serviced at the maintenance area.

5.6.4 Maintenance area

All parts of the tool assembly must be cleaned and inspected for damages after the blocks are removed from the lining. Damaged parts will be moved to the mechanical workshop for refurbishment.

Parts that have passed inspection and maintenance will be used again. Parts that are possible to repair will be reused, others will be scrapped and recycled. New parts such as linings, sealing rings, guide rings and seals for the tools must be kept in store.

Spare parts for the complete tool such as a ring, a bottom plate and an inner cylinder may be necessary to keep in store due to long delivery times for new parts.

Spare parts for the press and related systems shall be kept in store in accordance with recommendations from the press manufacturer.

The heavy machinery like the press and carousel and the related maintenance areas will need coverage by a heavy overhead crane, probably more than 25 tonnes.

Metallic waste, mainly discarded sealing rings should be collected in separate containers for ferrous and non-ferrous metals. To reduce the volume of metallic waste the rings can be cut to smaller sections using hydraulic shears.

For moving smaller objects traditional wooden pallets and manual pallet movers can be used.

Tool parts should be transported on specially adapted metal pallets using electrically powered moving equipment.

5.7 Isostatic compaction

The production of isostatic blocks will follow the process steps shown in Figure 5-6.

In isostatic compaction the raw material is placed in a soft and elastic rubber mould which is then submerged in a fluid. The pressure of the fluid is then increased which compacts the material in the rubber mould.

The isostatic press creates a pressure from all directions which has a number of advantages compared to uniaxial compression:

- (1) It is possible to make blocks that have a bigger height to diameter ratio.
- (2) It eliminates the friction against the mould.
- (3) Resulting blocks are expected to have a very homogeneous density.
- (4) Possible press several blocks at the same time.

The drawbacks are that:

- (1) The non-rigid mould causes the block to have variations in dimensions and, therefore all blocks need to be machined to the correct dimensions after compaction. Experience of mould technique will help to reduce the variation in dimensions of green body.
- (2) The compaction is done in radial direction as well as in axial direction which requires a bigger press than for the uniaxial compaction.

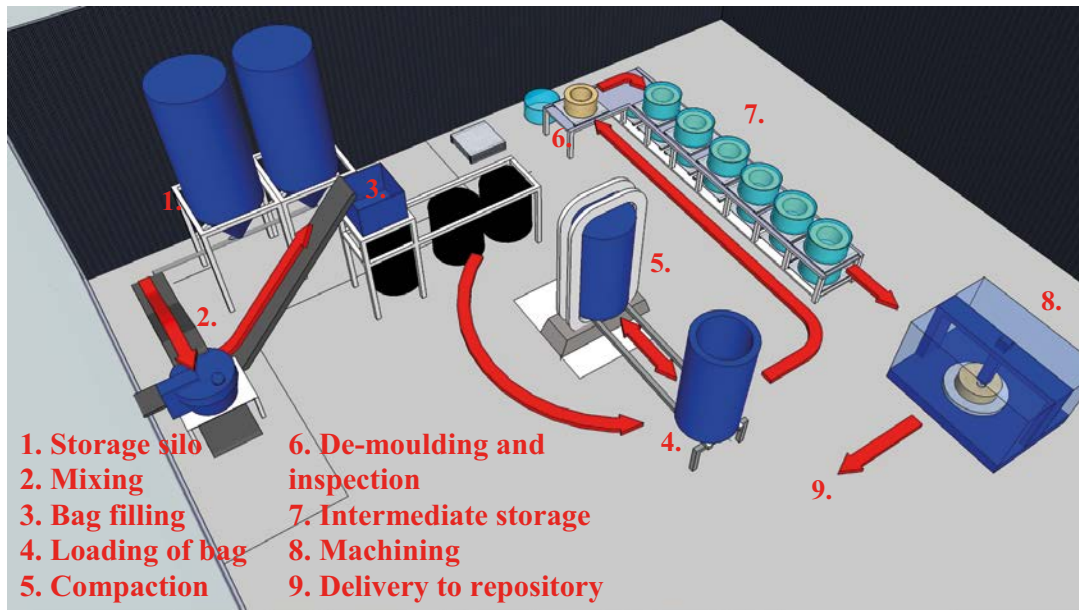

Figure 5-6. Illustration of block production with isostatic compaction.

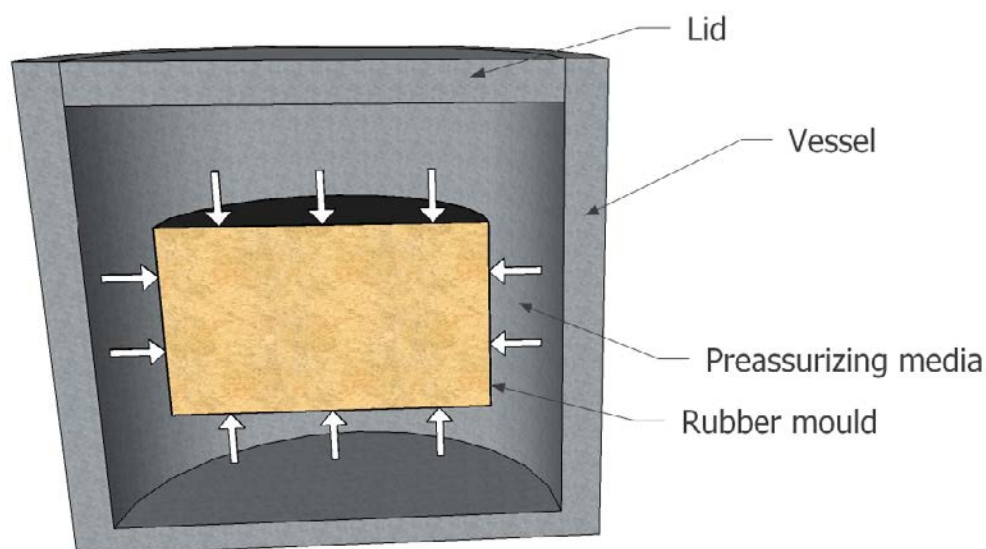

Figure 5-7. Illustration of isostatic compaction principles and parts.

5.7.1 Filling

The moulds used in isostatic compression are polyurethane or rubber bags placed in baskets. Bentonite is filled into the bags at a filling station where a batch of bentonite is fed into a hopper. The hopper is placed on a scale to achieve the correct batch weight. The same equipment is used to ensure that the hopper is completely emptied after each filling cycle.

A mechanical device is used to reduce free fall and to distribute the bentonite evenly in the bags to avoid material separation.

After filling, the bags/baskets are cleaned and inspected after which they are sealed and vacuum is applied.

Spills during filling and handling can be taken care of using a central vacuum unit with a system of pipes and flexible hoses in strategic locations.

5.7.2 Pressing

Pressing is done in an isostatic pressure chamber designed for 100 MPa with an internal diameter of 2,450 mm and height of 4,000 mm. The pressurizing media used for the compaction of bentonite blocks is water.

The isostatic vessel can be moved in and out of the press for charging and de-charging.

An optional second isostatic vessel can be used to decrease the loading time of the press.

The compaction starts with a slow increase in pressure until the maximal pressure is reached. The press is then kept at maximum pressure for approximately 24 minutes followed by a slow unloading of the pressure. This is necessary to give the air that is within the pores in the material time to be transported out of the material.

A preliminary cycle diagram for this press can be found in Appendix 2.

Depending on the height of the blocks to be manufactured, two or more baskets can be stacked on top of each other and interlocked before they are inserted in the isostatic vessel and moved into the press.

The isostatic vessel is moved out of the press at the end of the pressing cycle and the finished blocks are retrieved from their baskets/bags. After compaction and stripping the blocks will be transported with a lightweight overhead crane to the inspection area. This crane covers the main fabrication area and the area for inspection after compaction.

Equipment serving the press and various other installations on the factory floor such as hydraulic units, vacuum pumps, tanks, central vacuum units for waste management etc can preferably be placed in basement areas.

5.7.3 Maintenance area

The bags and baskets are cleaned and inspected after removal of every individual block. Parts that have passed inspection and maintenance will be used again. Repairable parts will be reused while others will be scrapped and recycled.

New parts such as bags and baskets must be kept in storage.

Spare parts for the press and related systems shall be kept in store in accordance with recommendations from the press manufacturer.

Polymer or metallic waste, mainly discarded bags will be collected in separate containers. To reduce the volume of waste the bags can be cut to smaller sections using hydraulic shears.

The heavy machinery like the press and the related maintenance areas will need coverage by a heavy overhead crane, probably more than 25 tonnes.

Internal transportation for moving smaller objects traditional wooden pallets and manual pallet movers can be used.

Larger objects should be transported on specially adapted metal pallets using electrically powered moving equipment.

5.8 Inspection and control

The finished blocks are inspected visually for outer defects after compaction. Other non-destructive inspection methods may be implemented later if suitable methods are found. If necessary, equipment for inverting the blocks for further inspection etc can be installed.

Dimensions and inspection results are recorded for each individual block. This data together with the water content measured after the mixing can be used to calculate the dry density for the block. If all these parameters are within the specification then the block will be approved otherwise the block will be discarded.

Approved blocks are placed on transportation pallets in individual covers.

5.9 Intermediate storage

The blocks swell after compaction, which is described in see Section 8.2. It is necessary to store the blocks in an intermediate storage until this swelling has subsided. If this is not done it will be difficult to achieve the desired dimensions during machining.

Based on measurements performed, see Section 8.2, recommended intermediate storage time is 4–6 days before machining. This means that the intermediate storage needs to be dimensioned for at least 48–72 blocks.

5.10 Machining

After 4–6 days in the intermediate storage the blocks are transported to a separate room for final machining.

Machining to final dimensions will be done by turning the blocks on a carousel lathe or machining them in a milling machine. This machine needs to be constructed so that atmosphere during machining can be kept at a constant relative humidity of approximately 75% in order to protect the blocks.

If isostatic pressing is used or if conical moulds are needed for uni-axial pressing it is likely that two machining stations are needed to have high enough capacity.

For isostatic compression it is assumed that 10–15% of the material has to be machined away which equals to approximately 2.5 to 3.75 tonnes per day. The material that has been machined away from the block may be recirculated in to the process again assuming that the material does not contain any foreign material. Recirculation will probably require reprocessing either in the harbour area or in the production facility.

A similar crane with a vacuum tool as used for moving the blocks from compaction to inspection will be used to lift the block in and out of the machining.

A final inspection is performed after machining and data is stored in the same way as during the inspection after compaction.



Figure 5-8. Milling of blocks during test production. In the real production the machine needs to be encapsulated and the relative humidity in the encapsulation controlled.

Finished blocks are placed on pallets and sealed with a cover ready to be delivered to the repository.

Equipment for dust extraction and removal of waste material is necessary. Blocks that are rejected will be discarded and possibly reprocessed.

5.11 Pellet pressing

Pellets can either be produced by roller compaction or by extrusion. The two methods will produce pellets with different properties but the area needed for the presses are similar and the choice of pellet production technique will not have any major effect on the facility layout.

The amount of pellets that needs to be produced for the buffer installation is rather small and even a small pellet press will have an overcapacity. Therefore it could be an option to buy the pellets from an external contractor.

5.11.1 Roller Compaction

Roller compacted pellets are produced by compacting the material between two rollers. Successful tests with manufacturing roller compacted pellets have been performed using equipment from Hosakawa. The pellet press used in these test is shown in Figure 5-9.

5.11.2 Extruded pellets

Extruded pellets have been produced at Äspö HRL using equipment from Amandus Kahl. The clay is in this process pushed through a metal matrix. The pellets produced this way have an elongated form and a slightly lower bulk density than roller compacted. The pellet extruder is shown in Figure 5-10.



Figure 5-9. Roller compaction of bentonite in a Hosakawa GS-25.



Figure 5-10. Pellet press for extruded pellets used for test production at Äspö.

6 Capacity

Estimations on the press-cycle-times have been done for both uni-axial and isostatic compaction. These press cycles are presented in Appendix 1 and Appendix 2. Note that the press cycles are based on the current level of advancement for both technologies and might be subject to future development.

For uni-axial compression it is estimated that the cycle time for producing one block would be approximately 20 minutes. This will mean that the daily production can be done in 4 hours not including re-tooling for the different type of block, rings and solid blocks. This re-tooling is estimated to take approximately 1 hour and the total capacity it depending on how often this re-tooling is made. If one re-tooling is made each day the average production time per block would be 25 minutes.

For isostatic compaction there is no need for re-tooling and several blocks can be compacted simultaneously. The press cycle-times are however longer, approximately 2 hours. This means that if an average of 3.5 blocks can be compacted in the same time, the daily production will be done in approximately 7 hours or 35 minutes per block.

Both of the compaction techniques are estimated to have enough capacity to be able to produce the required amount in one-day shift, 8 hours.

7 Complementary tests

The following complementary tests have been performed as part of the stepwise development of the manufacturing process:

- Lubrication – Study of different lubricants incl. the possibility to remove all lubricants.
- Swelling after compaction – Study of the change in size over time after compaction.
- Cylindrical mould – Development of a cylindrical mould (no need for machining).

7.1 Lubrication

7.1.1 Performed tests

In order to test several surface coatings and compare them with the MoS₂-lubricated mould, steel cylinders with a diameter of 50 mm and a height of 200 mm have been constructed and coated according to table 1. This is not the same diameter to height ratio as the mould used for compaction of full-scale buffer blocks but the smaller diameter to height ration makes the differences bigger and it is easier to compare the results between the different lubrications. A bottom plate for the cylinders with an incorporated air drain is used.

The compactions were made with two different compaction pressures, 100 MPa and 50 MPa.

Three different water ratios: 12.5%, 17% and 25% were used for the MX-80 raw material.

The density of solid particles in the material is assumed to be 2,780 kg/m³.

The following coatings were tested:

- MoS₂-lubricant.
- MoS₂ Varnish.
- Graphite varnish.
- PTFE varnish.
- PTFE fodder.
- Electroplated chromium.
- NEDOX FM-5.
- Uncoated.

7.1.2 The compaction process

To start with, the bottom plate was bolted to a cylinder and sealed with a greased rubber o-ring. Then a filter was placed over the bottom plate air drain inside the mould and on top of it a copper sealing ring was placed to prevent clay from escaping the cylinder. The clay was then put into the cylinder. Another sealing ring and a filter were finally placed on top of the clay.

To make the 100 mm high sample of compacted clay with a density approximated to 2,000 kg/m³ yields the required clay mass 392.7 g. Figure 7-1 shows a mould together with piston, filter and gasket.

The mould was then put into an Enerpac VLP256 P392 ram, shown in Figure 7-2, and a vacuum pump was connected to the air drain in the bottom plate. This was to make sure as much as possible of the air in the clay is transported out of the sample during the compaction process.

A piston with the same coating as the cylinder was then used to compress the clay in the ram with a force equivalent to the appropriate pressure. The force was calculated using the top area of the piston and the compaction pressures, which yields 196.2 kN and 98.17 kN respectively for 100 MPa and 50 MPa. The ram hydraulics is pumped manually and when the right force is attained the load is immediately removed.



Figure 7-1. The mould and piston (left), and the same mould upside-down together with the filter and copper sealing ring on top of the piston (right).



Figure 7-2. The Enerpac VLP256 P392 ram (left) and the Luna ABS 500 band saw with a partly cut sample (right).

The vacuum pump was then disconnected and the mould turned upside-down to allow the removal of the bottom plate. When the bottom plate was removed the sample end was marked to keep track of up and down. The compacted sample was then pressed out of the cylinder by having the mould stand on the piston and pressing on top of the cylinder with a cap big enough to fit the whole sample. Free of the cylinder, the compacted sample was cut into ten slices in a band saw, also in Figure 7-2. The slices are divided in two half circle pieces and put in marked containers to preserve their water ratio until the measurements were performed.

7.1.3 Complications

In most cases the moulds were functioning properly. Abnormalities are listed below.

- Lubrication of the mould with MoS₂-based grease was made with a brush and after the compaction the sample surface was soaked with the lubricant. To mend this, the outer 2 mm, was cut of the sample before being sliced in the band saw.
- The varnish in moulds with graphite varnish and NEDOX FM-5 had a tendency to form a layer on the sample, especially noticeable on the upper part. This was probably due to the longer travel inside the mould that the sample top has made during both the compaction process and the pressing out of the mould.
- Mould with PTFE fodder was relatively soft which unfortunately made the upper copper sealing ring dig into it during the first compaction and made some damage in the form of an oblong cavity. The cavity was reaching from about the middle to the bottom of the mould in a sloping manner it may have had some impact to the results in the following compactions. The depth of the cavity was about 3 mm at the top end and a third down it decreased to about 1 mm. To prevent more damage to the fodder, the following compactions were made without an upper copper sealing ring.
- The PTFE fodder in mould was also a bit complicated during the extrusion because it tended to slide against the surrounding cylinder instead of the sample sliding against the fodder.
- The only mould in which the piston kept jamming was the one with electroplated Chromium. This mould was also very hard to clean after the compactions because the clay dug in to the cylinder surface.

7.1.4 Measurements

Density measurements were made using Archimedes principle by first weighing one half of each slice hanging in air from a thread and then lowered into paraffin oil with a density of 882.8 kg/m³. Because air bubbles tended to stick to the sample when it is put into the oil, the surfaces of those slices were scraped with a knife to make them smooth.

To measure the water ratio, the other half of each slice was weighed immediately after the cutting of the sample and then weighed again after having been dried in a 105°C hot oven for 24 h or longer.

Then the density, dry density and void ratio distribution profiles were calculated throughout the depth of all the samples based on the density- and water content measurements.

7.1.5 General results

Most compacted samples turned out as expected without any defects. The only samples that were problematic originated from the mould with PTFE fodder or the series of compactions with 12.5% water content and 100 MPa.

When compacting in the NEDOX FM-5 and uncoated mould with water content 12.5% and 100 MPa cracks surrounding the samples could be seen at, respectively, 20 mm and 15 mm distance from the top. All the compactions with water content 12.5% and compaction pressure of 100 MPa had some cracks surrounding the top, leaning slightly towards the centre.

The samples compacted in the damaged PTFE fodder mould had scratches on the side that had been in contact with the damaged fodder.

7.1.6 Calculated data

Calculated density, dry density and void ratio profiles in the compacted samples are presented in the Appendix 5. To make the comparison of samples from different series of water ratio and compaction pressure easier, the dry density has also been transformed into a relative plot format in Figure 7-3 to Figure 7-7. This show the dry density values in relation to the maximum value in each compacted sample. In an optimal case, all the values from a sample should be ones in the relative dry density plots.

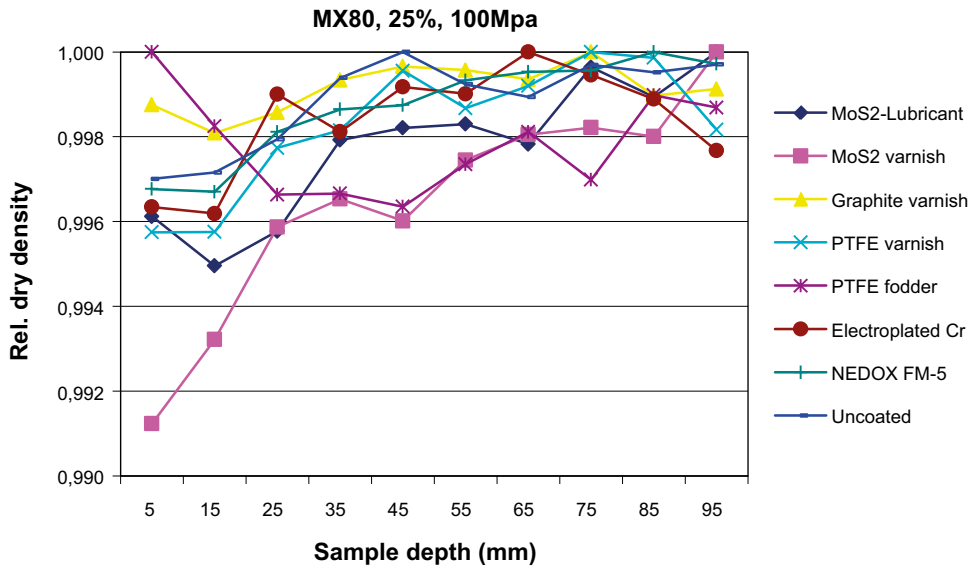

Figure 7-3. Plot of the relative dry density profile for the samples which had a water content of 25% and 100 MPa.

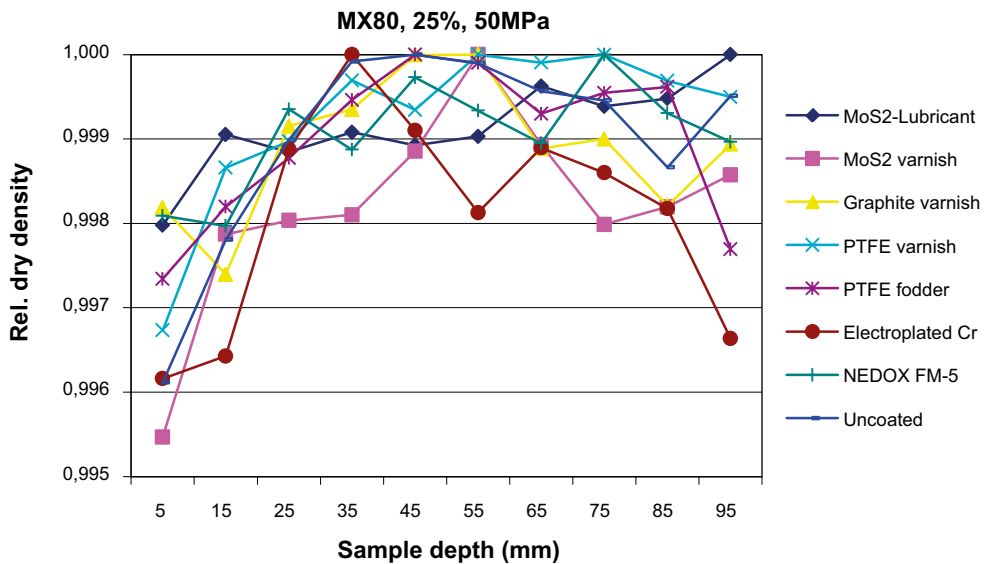

Figure 7-4. Plot of the relative dry density profile for the samples which had a water content of 25% and 50 MPa.

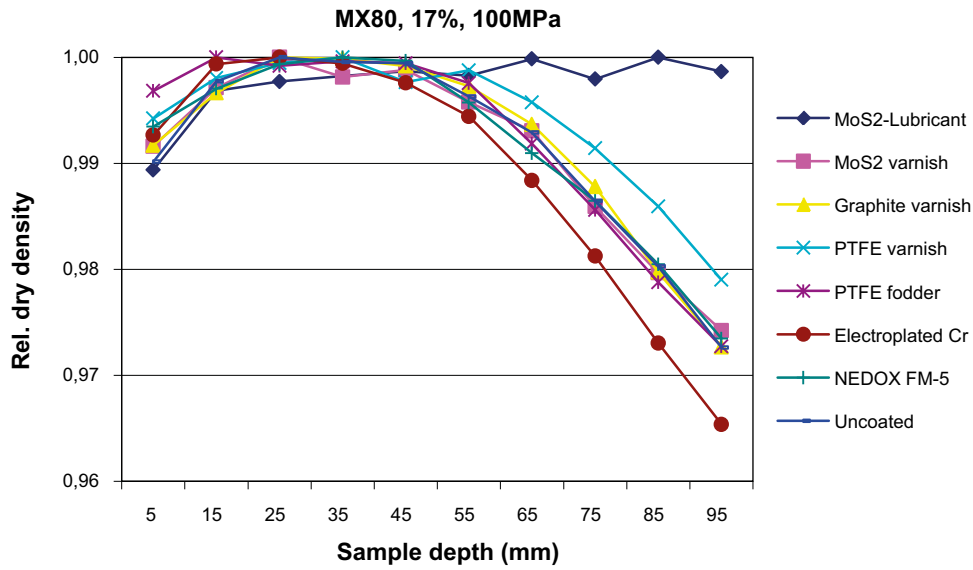

Figure 7-5. Plot of the relative dry density profile for the samples which had a water content of 17% and 100 MPa.

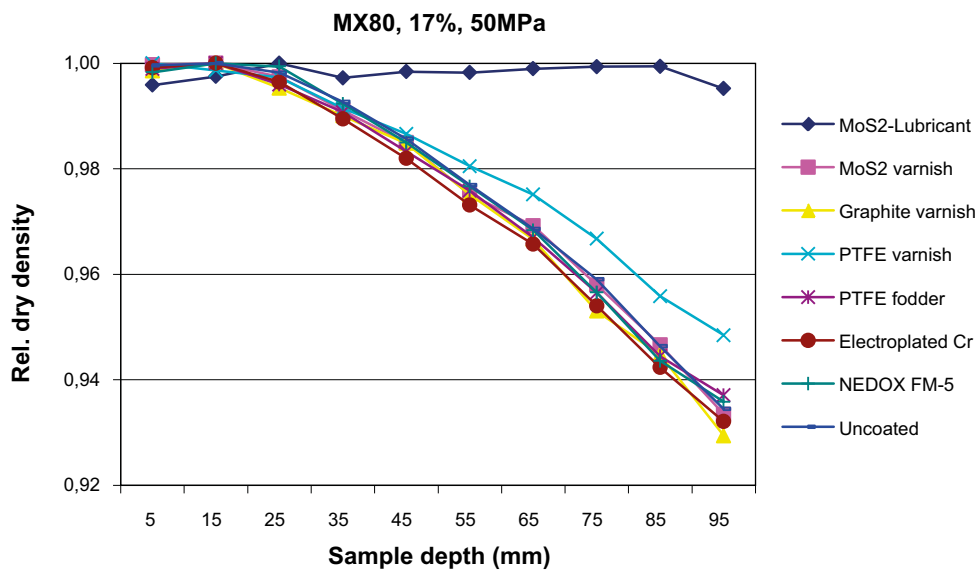

Figure 7-6. Plot of the relative dry density profile for the samples which had a water content of 17% and 50 MPa.

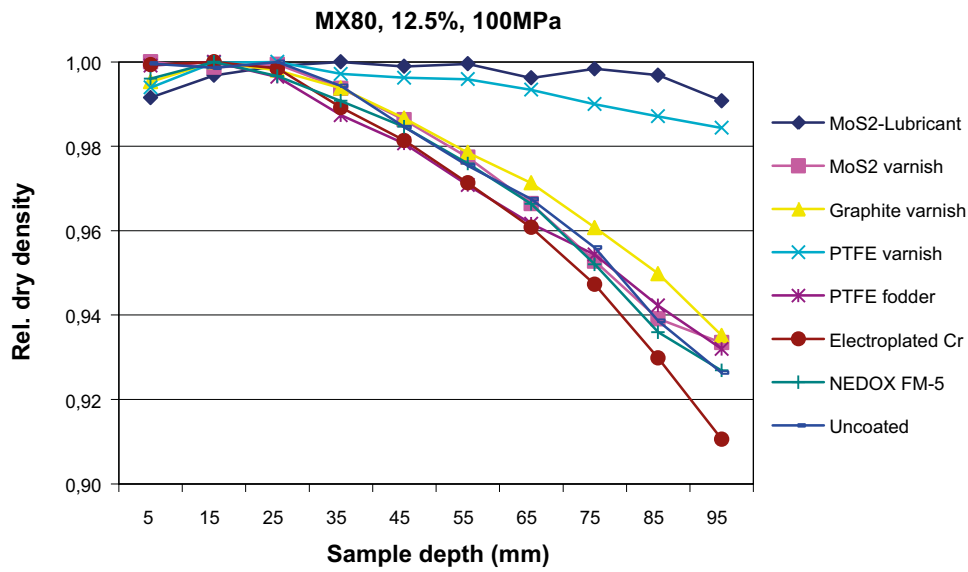

Figure 7-7. Plot of the relative dry density profile for the samples which had a water content of 12.5% and 100 MPa.

7.1.7 Discussion

In order to be able to compare the different block types and the effect of lubrication a simple model is formulated. With help from this model we can then estimate how the measured results translate to a full-scale block.

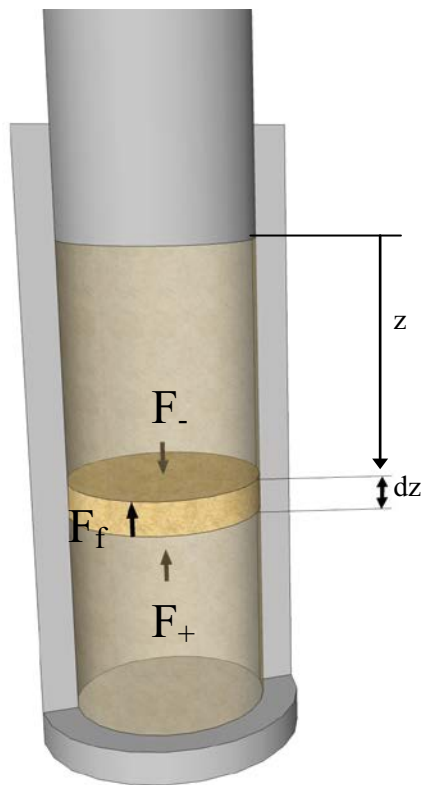

Figure 7-8. Illustration of forces during compaction.

The Force acting upon the top face of the disc is:

$$F_- = A\sigma(z) = \pi r^2 \sigma(z) \quad 7-1$$

Where A is the area to which the force is applied and $\sigma(z)$ is the pressure at the distance z from the piston.

The Force acting upon the bottom face of the disc is:

$$F_+ = A\sigma(z + dz) = \pi r^2 \sigma(z + dz) \quad 7-2$$

The frictional force acting upon the lateral face of the disc is:

$$F_f = N\mu = 2\pi r \sigma(z) dz \mu \quad 7-3$$

Equilibrium of forces resides when

$$F_+ - F_- = F_f \quad 7-4$$

From (4.17) to (4.20), it follows:

$$d\sigma = \sigma(z + dz) - \sigma(z) = - \frac{2\mu\sigma(z) dz}{r} \quad 7-5$$

Integration of this differential equation yields:

$$\sigma(z) = \sigma(0) e^{-\frac{2\mu}{r}z} \quad 7-6$$

For a ring shaped block, assuming hydrostatic condition, the same equation would be:

$$\sigma(z) = \sigma(0) e^{-\frac{2\mu(r_o + r_i)}{(r_o^2 - r_i^2)}z} \quad 7-7$$

However since the block expands in radial direction when it is compacted it is likely that the pressure against the mould at the inner radius is reduced. Therefore a coefficient is introduced which will have a value between 0 and 1.

$$\sigma(z) = \sigma(0) e^{-\frac{2\mu(r_o + Cr_i)}{(r_o^2 - r_i^2)}z} \quad 7-8$$

To calculate the density from the compaction pressure an empirical expression is used.

$$\rho(z) = A \ln(\sigma(z)) + B \quad 7-9$$

This expression seems to work well in the pressure interval of interest, see Figure 7-9, with the constants chosen according to Table 7-1.

With equation 7-9 a density distribution in the test blocks can be calculated where the slope of the curve equals the friction coefficient. If the friction coefficient, μ , is constant we will get a straight line, however in the test samples the friction coefficient seems to be reduced in the top of the sample where density is higher, see Figure 7-10. This is likely caused by material flow is going towards the centre releasing the pressure against the outer wall. It is assumed that the depth of this zone is half the diameter of the mould.

Table 7-1. Constants for different material models.

| Material | A | B |
|---------------------------|-----|------|
| MX-80, w=12%, 2012 | 204 | 1240 |
| MX-80, w=10%, 1993 | 176 | 1240 |
| MX-80, w=12%, 2008 | 190 | 1240 |
| MX-80, w=17%, 2012 | 124 | 1594 |
| MX-80, w=17%, 2008 | 112 | 1594 |

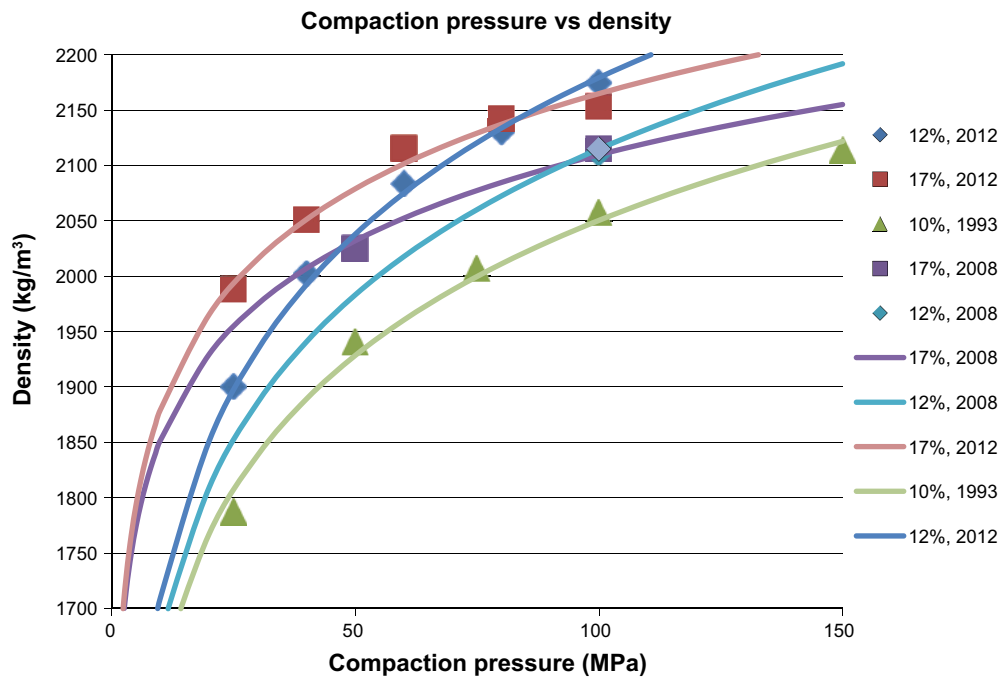

Figure 7-9. Compaction pressure versus density for different deliveries of MX80 clay.

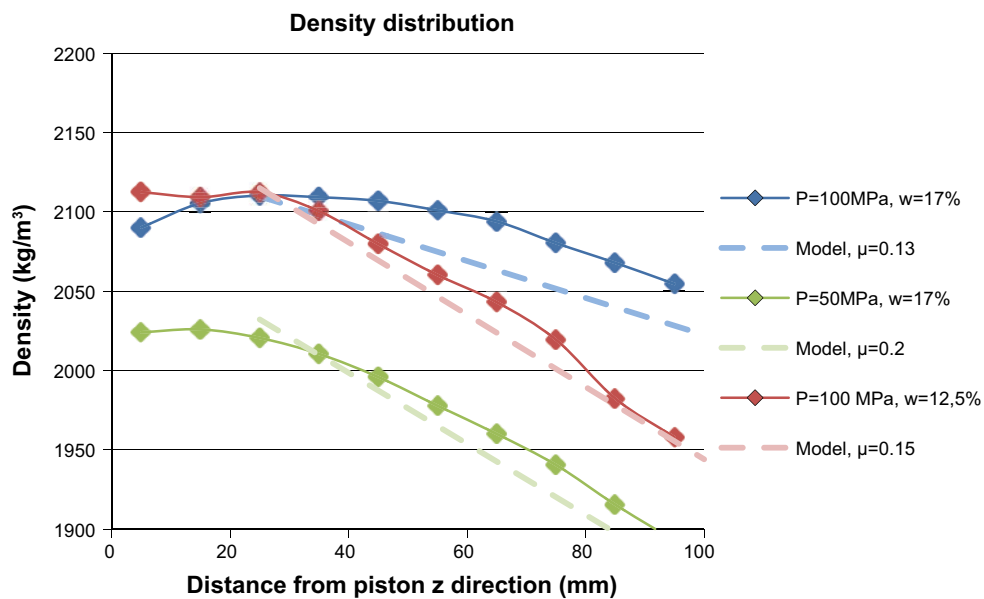

Figure 7-10. Comparison between experimental values and analytical model.

To find out if degree of saturation could be affecting the friction coefficient it is plotted against the slope of the density curve, i.e. the friction coefficient, Figure 7-11. It seems that this could explain why the density distribution is not linear.

To find out the value of C in equation 7-8; data from Johannesson and Börgesson (1998) is used, see Figure 7-12. If the degree of saturation is calculated at the bottom for the 10.3% non lubricated case gives a saturation of 53%. Using this and data in Figure 7-11 C is chosen to give the same slope as in Figure 7-12. Through this C is approximated to 0.5.

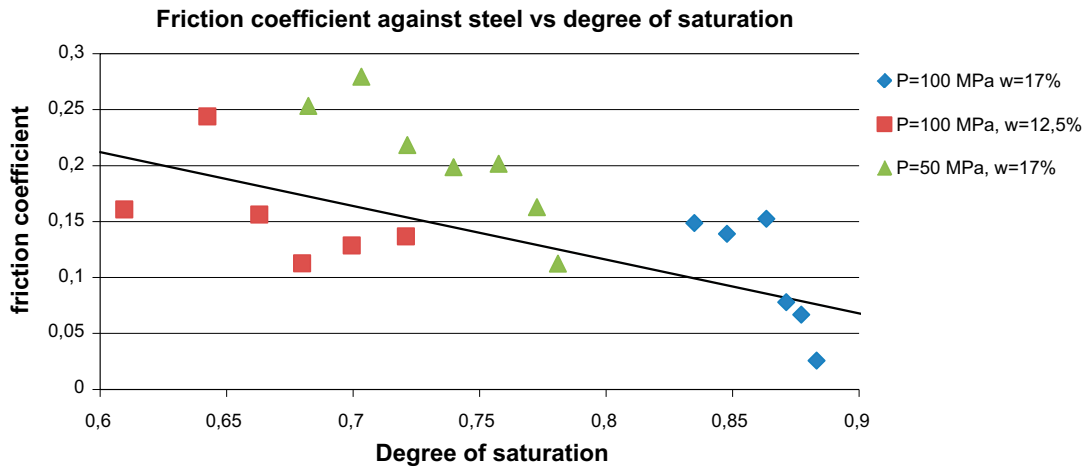

Figure 7-11. Saturation vs. friction coefficient.

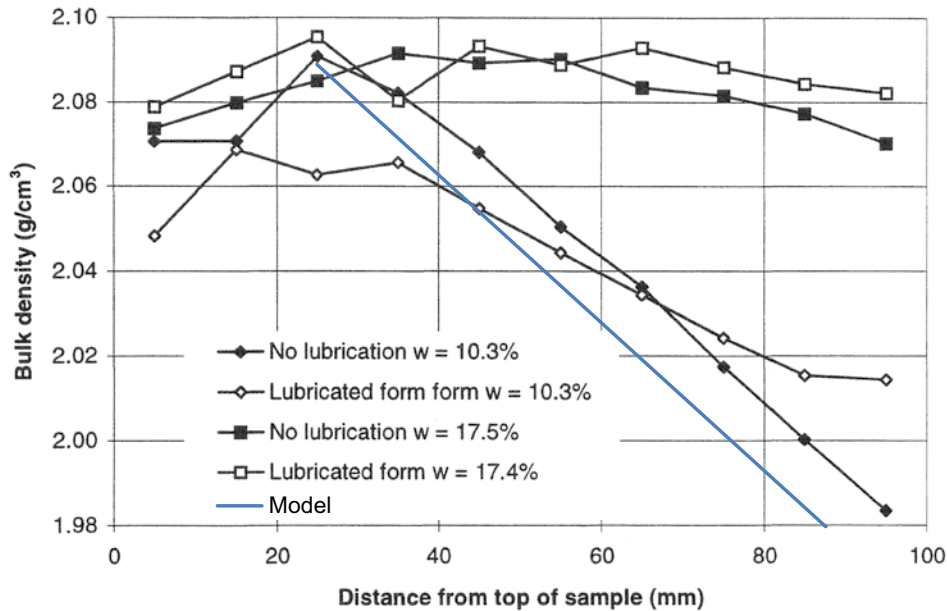

Figure 7-12. Fitting of constant C in eqv. 8-8 to a ring shaped block.

For an 800 mm high buffer ring the density distribution in axial direction can then be calculated with:

$$\rho(z) = -2A\mu \frac{r_o + 0.5r_i}{r_o^2 - r_i^2} z + B + A \ln(\sigma(0))$$

If the following values are used; the density distribution will be as seen in Figure 7-13.

A=124

B=1,594

$r_o=825\text{mm}$

$r_i=535\text{mm}$

$\sigma(0)=50\text{MPa}$

For the case that the friction coefficient is dependent on the degree of saturation, which seems likely, the difference in density in the block should be rather small. It is therefore likely that the block can be produced without lubricants. However the estimation is done with very simple methods and further investigations are needed before this can be absolutely certain.

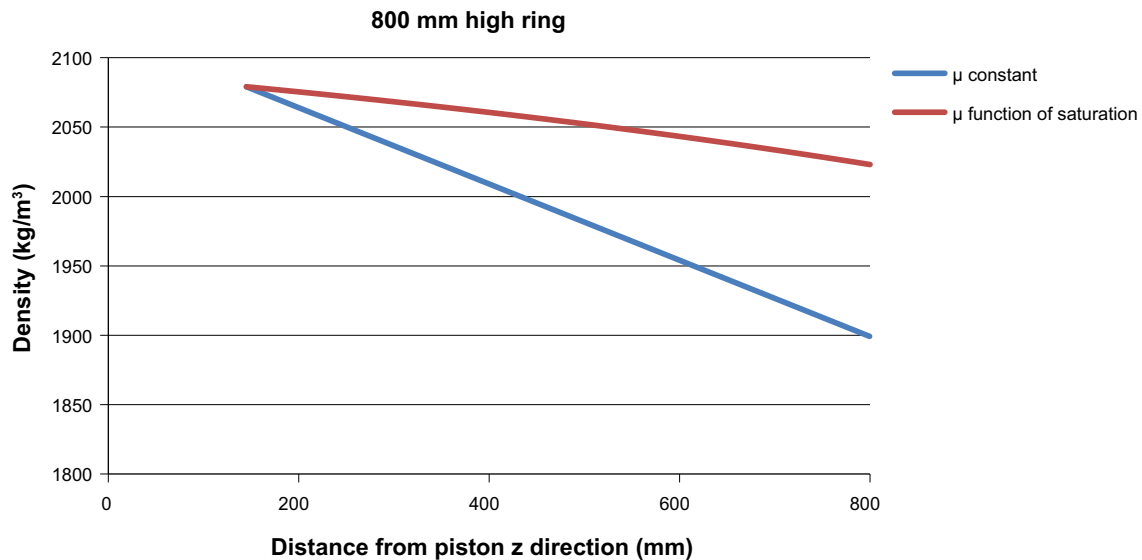

Figure 7-13. Average density distribution in the axial direction of the block according to model with constant coefficient friction and with a coefficient of friction dependent on saturation.

7.2 Swelling after compaction

It is known that the blocks continue to swell after compaction but it was not fully known for how long time this swelling continues. This parameter is important to know in a production facility to get the accuracy needed to fulfil the specified dimensions of the blocks.

The blocks need to have stopped, or greatly reduced, its swelling rate before machining to be able to machine to the correct dimensions. Therefore a test has been done in order to find out the swelling behaviour over time.

A full-scale block was placed in a container directly after compaction. Three measurement probes were placed on top of the block measuring axial swelling and three probes were placed on the sides of the block measuring radial swelling. These probes were placed with an even spacing 120 degrees between each other. The swelling was then recorded for approximately 6 days. The results are shown in Figure 7-14 and Figure 7-15.

From the results we estimate that it will take 4–6 days before most of the swelling rate has subsided. It is therefore recommended that the blocks be placed in an intermediate storage for 4–6 days after compaction before the blocks are machined.

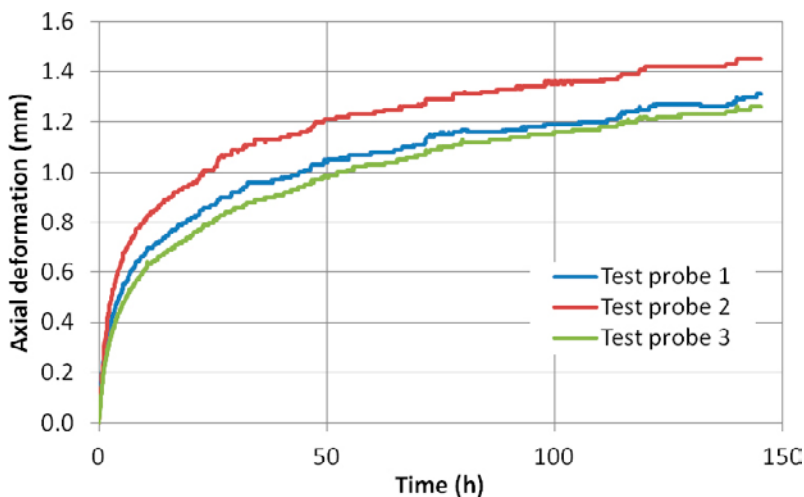

Figure 7-14. Swelling of the block after compaction in axial direction.

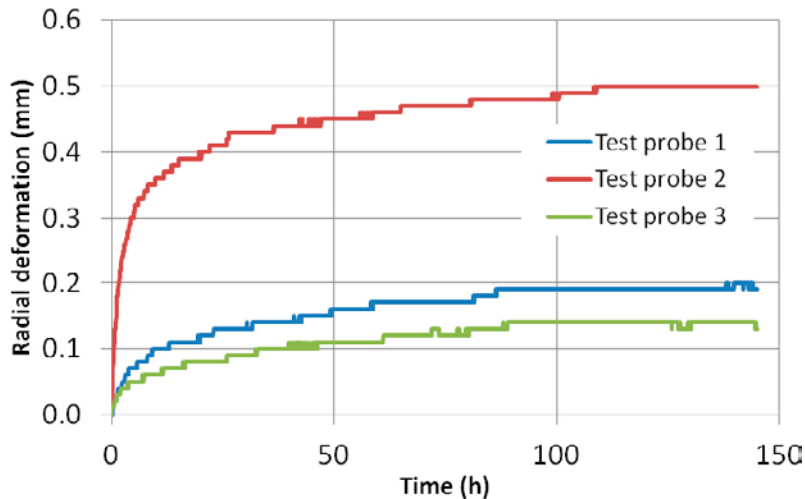

Figure 7-15. Swelling of the block after compaction in radial direction.

7.3 Cylindrical mould

The current mould with a conical shape has a big disadvantage in that the blocks require quite a bit of machining. Additional work is also required during the removal of the finished block from the mould as the mould has to be lifted of the block before it can be removed.

Based on these disadvantages, a new mould has been designed which has a cylindrical shape reducing the need for machining and a lining to simplify removal of the block from the mould. The new mould design with the load-bearing cylinder and inner lining can be seen in Figure 8-16.

The lining is split in three parts at an angle to the radial direction to ease the removal of the block. Inside the lining two sealing rings are placed to avoid that bentonite is pushed out of the mould through the gaps. An upper tool, placed on top of the bentonite, is then used for the compacting the block.

The lining will, after compaction, be removed from the load-bearing cylinder of the mould together with the block during de-moulding. Therefore it protects the block from shearing forces during extrusion, which could otherwise be a problematic part of the process as the block swells when extruded which causes stresses that could harm the block. The protective lining also removes the friction between the block and the mould during the extrusion of the block, which will instead be located between the lining and the load bearing part of the block. This will greatly reduce the risk of getting cracks in the block during de-moulding, especially if no lubricants are used.

A scale 1: 5.5 prototype of this new mould design has been developed, manufactured and tested. The prototype mould had the same height to diameter ratio as an 800 mm high full-scale block and has been tested with three different water contents and without lubricants. The blocks were after compaction cut in pieces and dry density was measured. The block had good quality and showed only a small variation in dry density see Figure 7-18. The measured data is presented in Appendix 5.

Table 7-2. Compaction data from test of cylindrical mould.

| Test | Water content (%) | Compaction pressure (MPa) | Diameter (mm) | Height (mm) | Average bulk density (kg/m ³) | Average dry density (kg/m ³) |
|------|-------------------|---------------------------|---------------|-------------|---|--|
| 1 | 10.7 | 63 | 301.14 | 148.3 | 2088 | 1886 |
| 2 | 16.3 | 55 | 300.53 | 145.5 | 2090 | 1796 |
| 3 | 20.3 | 37 | 299.74 | 146.72 | 2076 | 1725 |

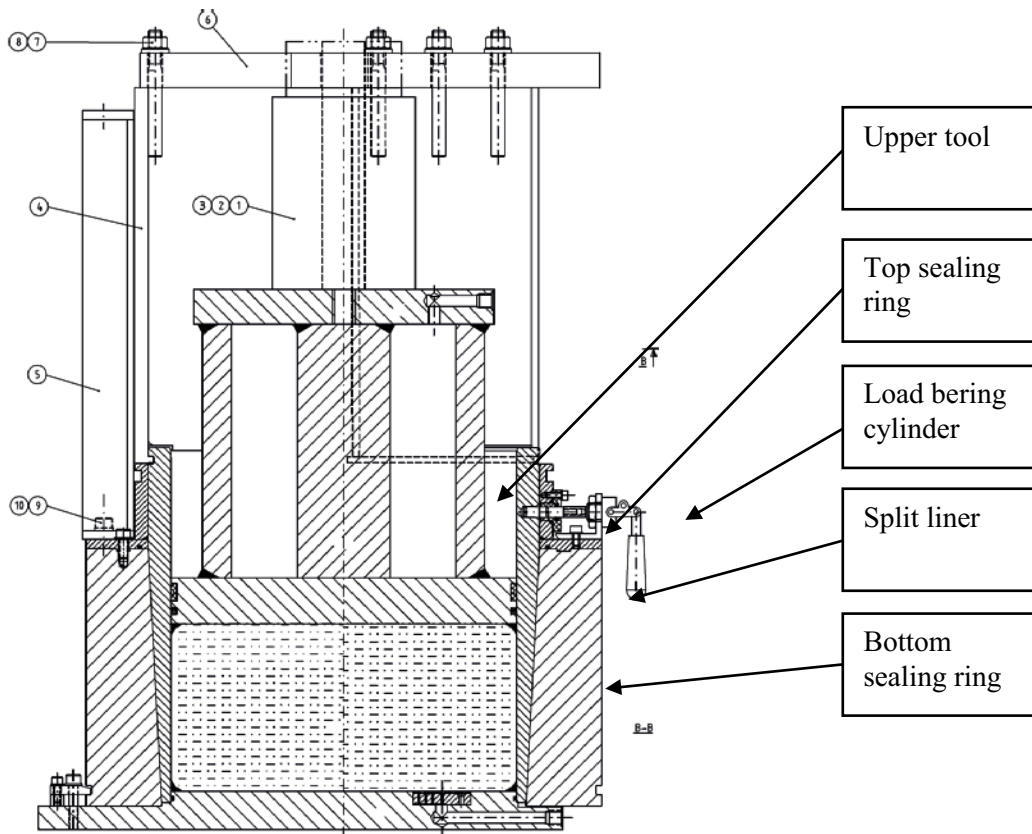

Figure 7-16. Design of scale mould for cylindrical blocks.



Figure 7-17. Scale block with 300mm in diameter produced with prototype cylindrical mould and no lubricants.

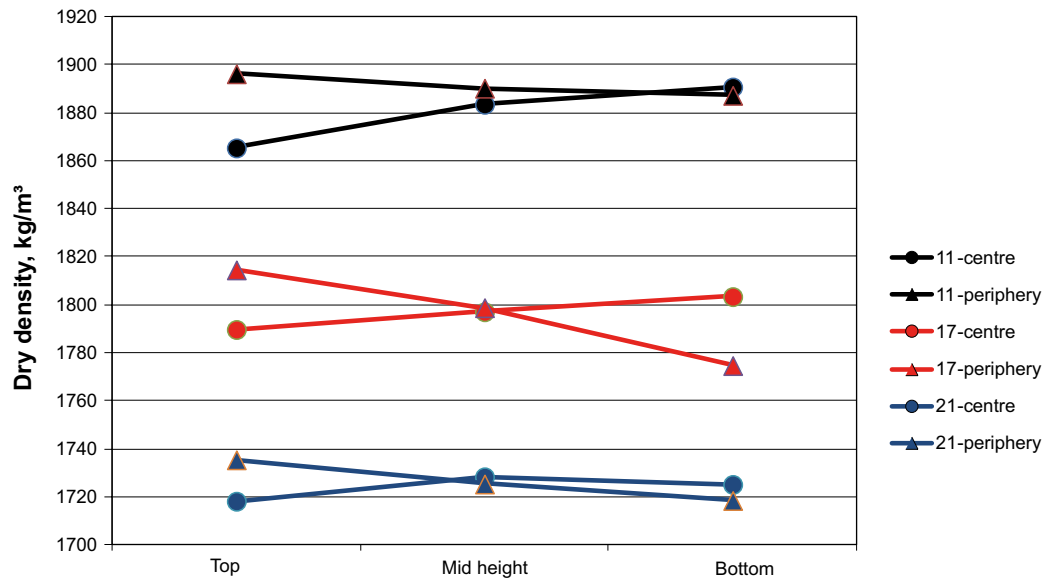

Figure 7-18. Density distribution for block with three different water contents.

References

SKB's (Svensk Kärnbränslehantering AB) publications can be found at www.skb.se/publications.

Börgesson L, Hernelind J, 2014. Modelling of bentonite block compaction. SKB P-14-10, Svensk Kärnbränslehantering AB.

Johannesson L-E, Börgesson L, 1998. Compaction of bentonite blocks. Development of techniques for production of blocks with different shapes and sizes. SKB R-99-12, Svensk Kärnbränslehantering AB.

Ritola J, Pyy E, 2012. Isostatic compression of buffer blocks –middle scale. Posiva Working Report 2011-62, Posiva Oy, Finland.

SKB, 2010. Design, production and initial state of the buffer. SKB TR-10-15, Svensk Kärnbränslehantering AB.

Preliminary cycle diagram uni-axial press

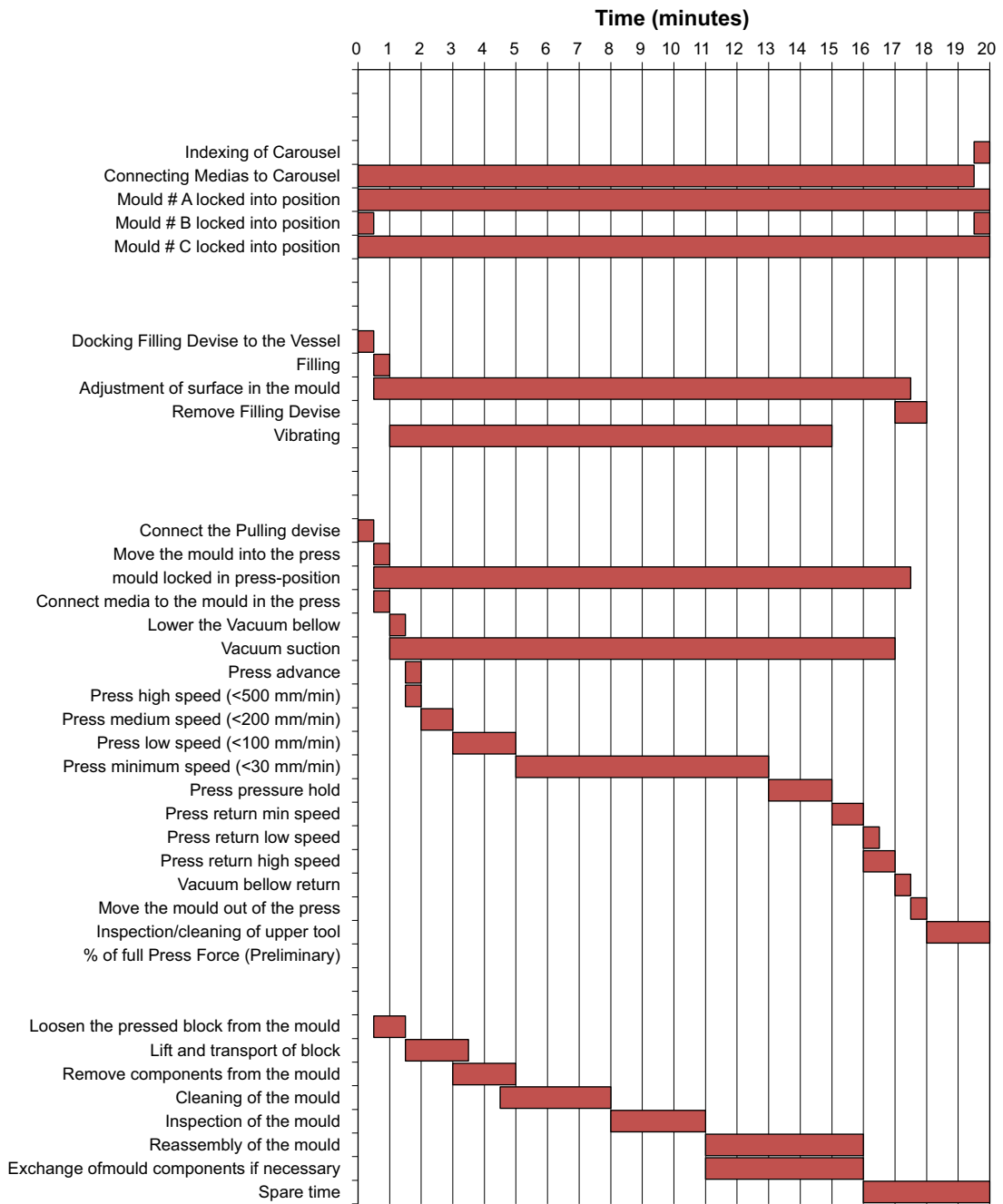

Preliminary cycle diagram cold isostatic press

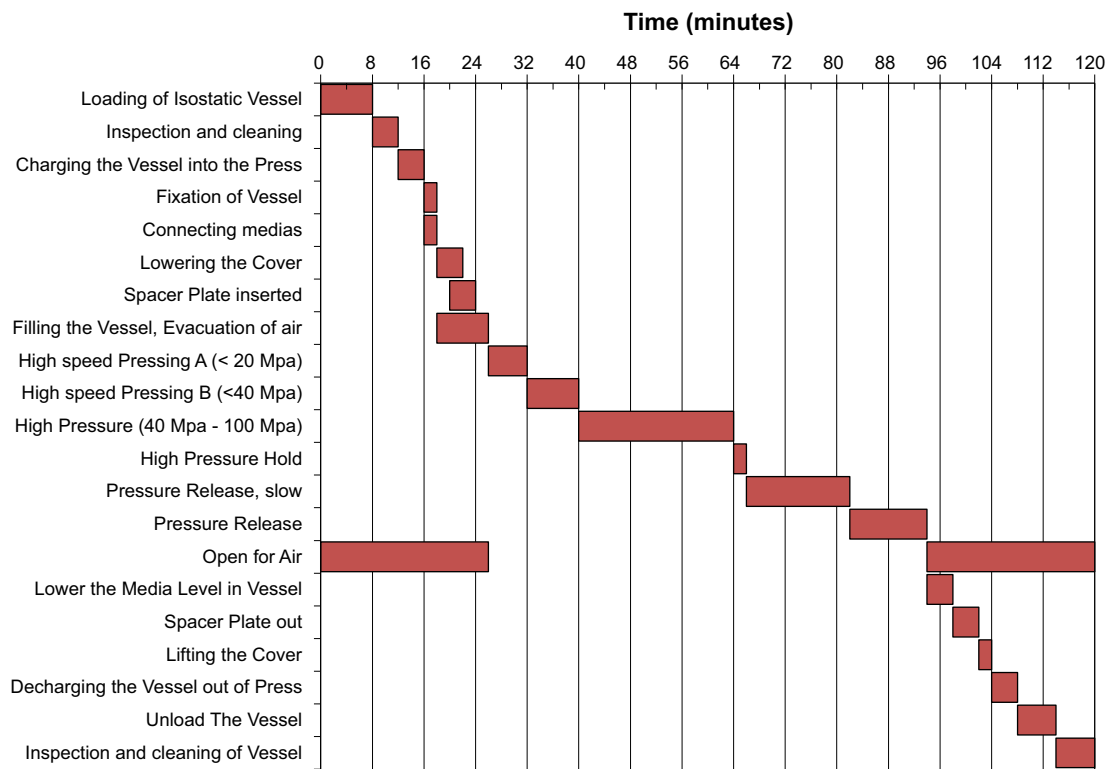

Preliminary specification uni-axial press **Technical Specification Compact press 26,000 Ton**

Håkan Knutsson, FENIX Engineering AB

Helsingborg 2013-02-20

Background

This specification is the technical part of a preliminary specification of requirements for an uniaxial compact press, 26,000 metric tons including auxiliary equipment. The press system will be part of a production plant for continuous production of buffer components intended for deep deposition of used nuclear fuel.

General description of the press system

The system shall produce a large number of blocks compressed from bentonite clay. The blocks to be produced are mainly, but no necessarily, of two shapes: rings or massive cylinders. The final outer diameter is 1,650 mm, the height is 800 mm.

To achieve the required capacity, the project has chosen to study a system consisting of a press with a three position carousel for filling, charging and de-charging.

Required cycle time: 20 min. Also see appendix 1.

This specification should be regarded as preliminary as development/evaluation of production, components, products etc are still going on.

Short on bentonite

- Bentonite is a natural material extracted on many locations of the world, including Sweden.
- The bentonite is delivered to the production plant in large batches. It is processed before it arrives at the pressing plant. This includes crushing, screening, adjustment of water content etc. Various tests are performed on each batch. The results are filed together with other process records.
- Bentonite mainly consists of clays in varying fine fractions. This means that the material generates dust, especially when it becomes dry. Great attention shall be directed partly towards making all designs dust resilient but also towards avoiding anything that may contribute to the generation of dust.
- The granulated bentonite is stored in silos in an area adjacent to the pressing plant. From there every batch is weighed and stored in a container near the "filling station".
- When the tool is in the correct position a filling device is docked to the lower part of the tool. The bentonite is fed with a screw conveyor and distributed in the lower part of the tool. When filling is complete the filling device is undocked and moved to its waiting position.
- Bentonite storage, conveyors, filling equipment etc are placed in areas separated from the pressing equipment. All equipment is designed with relevant dust protection.

Ingoing requirements, functions and components

The following functions/components shall be included in the press system.

General

- All included components and systems shall fulfil valid national and European norms and regulations.
- This description mainly specifies functions. All equipment such as fasteners, cables, piping, hydraulic systems etc necessary for each function shall be included in a tender/delivery.
- Working platforms, lifting equipment and other production appliances will be supplied by the purchaser unless specified below.

Press

- Uniaxial, single cylinder.
- Pressing force:

| | |
|-----------|--------------------|
| Operation | 22,000 Metric tons |
| Design | 26,000 Metric tons |
- Pressing speed: Fast, pressing, return: See appendix 1
Pressing speed shall be continuously adjustable within a given power interval.
- Light opening
 - Height between lower table and top of cylinder: Approx. 1,800 mm
 - Internal free width between columns: Approx. 2,350 mm
- Stroke Ca 1,000 mm
- The press shall be equipped with a system for charging the tools in and out of the press from and to the carousel.
- The press is equipped with a docking station for supplying electrical power, signals, vacuum, pressurised air and hydraulics to the tool when it is in the press. The docking station is equipped with a locking system for the tool in the pressing position.
- The press shall be equipped with a system for vacuuming the tool during the pressing sequence. This may consist of a vacuum pump connected to a tank acting as an accumulator, the necessary connections and a bellows connected to the upper tool and sealing against the lower tool during the pressing cycle. This system contributes to the reduction of dust spreading during pressing. The vacuum system shall be equipped with a filtering device or a dust separator to avoid dust intruding into the system.
- The press shall be equipped with a cover for the lower table. The cover will follow the tool when moved in and out of the press.

The cover shall be used as a working platform for inspection and cleaning of the upper tool between each pressing cycle.
- The press shall be equipped with a system for rapid replacement of the upper tool.

Carousel

- Shall index in three (3) positions: filling, charging to the press, de-charging/service.
- The carousel shall be able to index without tools as well as with one, two or three tools.
- The carousel is equipped with a system for locking the tools in their positions.
- The carousel is equipped with a docking station in each position for supplying electrical power, signals, vacuum, pressurised air and hydraulics to the tool when in the carousel.
- In the filling position:
 - A filling device will dock to the lower tool and a filling sequence starts. (The filling device is not part of the scope of the pressing system.)
 - A vibration device shall be included in the filling station for vibration in a linear, strictly vertical direction. The vibration shall be adjustable regarding amplitude and frequency. The carousel itself shall be insulated against vibration.

- In the charging position:
 - The tool is released from the carousel and moved into the press.
 - After pressing the tool is returned to its position on the carousel and locked in position.
- In the de-charging/ servicing position.
 - The finished bentonite block may be released from the toll with a release system integrated in the carousel.
 - The block is lifted out of the tool with a lifting device and moved to a station for inspection and further processing. (The filling device is not part of the scope of the pressing system.)
 - The lower tool is cleaned, probably by hand. Sealing rings, seals and the main components of the tool is inspected regarding damages, cleanliness, positioning etc.
 - In this position it shall be possible to unlock a complete tool and remove it from the carousel for servicing.
- It shall be possible to use the carousel to remove the upper tool from the press for service or replacement.

Hydraulic system

- The press system shall be delivered with a complete hydraulic system. The supplier shall propose whether auxiliary equipment such as carousel, charging etc. shall be powered by hydraulic or electrical power.
- The pressing cycle shall be possible to optimize regarding pressing speed, stroke length, holding time etc for best productivity and quality. Also see appendix 1.
- The intention is to locate the hydraulic system in a space below floor level alongside the press.

Electrical and I&C systems

- The press shall be equipped with a digital stroke measuring system.
- The press cycle (speed, press force, holding time, etc) shall be programmable.
- The press system shall be prepared for logging every single press cycle. The data logging device itself is not included in the delivery.

Pressing tools

- The tooling is still object for development and testing. The design shall be made in close cooperation with the Purchaser.
- A complete set of tools consists of three (3) lower tools and two upper tools, one for blocks plus one for rings. The lower tools can be equipped with an inner cylinder for the production of rings.
- The lower tools are placed on the carousel and one of the upper tools is mounted on the cylinder in the press.
- The lower tools are built on a bottom plate. This can be locked to the carousel in the different positions and they are designed for transport in/out to/of the press.
- Both upper and lower tools are equipped with channels for vacuum suction during pressing. The channels enter the process chamber where positions for metallic filters are made.
- The vacuum system shall be able to be pressurized with air at the decharging position to ease up the loosening of the blocks/rings.
- The vacuum suction is activated when the tool is placed in the press.
- The lower tools shall be equipped with a system for unloading the blocks/rings. This system is activated in the decharging position.

- Pressure at compression: <100 MPa
- Filling height: 1,600 mm
- Dimensions on the finished products (compressed bentonite blocks):
 - Massive blocks:
 - Diameter: Ø1,650 mm
 - Height: 800 mm
 - Rings:
 - Diameter: Ø1,650/ Ø1,070 mm
 - Height: 800 mm
- The lower tools shall be designed so that the radial elasticity is minimized both for outer diameter and inner diameter (the latter applies to rings).

Spare parts

- The supplier is requested to make a recommendation for spare parts to be held in storage to ensure the production.

Service and maintenance

The supplier is requested to deliver the following information:

- Weight and dimensions of components regarding lifting capacity for maintenance and service.
- Erection requirements.
- Maximum eccentric load in the press.
- Required carrying capacity for the flooring around the press and to/from the press.
- Requirements for medias, such as electrical power, cooling water, ventilation etc.
- Space requirements around the pressing equipment for maintenance and service.
- Space requirements for electric and hydraulic installations.
- Need of special tools for maintenance and service.

Preliminary specification isostatic press **Technical Specification Cold Isostatic Press 100 MPa**

Håkan Knutsson, FENIX Engineering AB

Helsingborg 2013-03-01

Background

This specification is the technical part of a preliminary specification of requirements for a cold isostatic press, 100MPa, Di Ø2,450 mm, H 4,000 mm and auxiliary equipment. The press system will be part of a production plant for continuous production of buffer components intended for deep deposition of used nuclear fuel.

General description of the press system

The system shall produce a large number of blocks compressed from bentonite clay. The blocks to be produced are mainly in the shapes of rings or massive cylinders, both types of varying dimensions.

To achieve the required capacity the project has chosen to study a system consisting of a press with a sufficient inner height to press several blocks per cycle. They are normally placed on top of each other.

Cycle time: 120 min. Also see appendix 2.

This specification should be regarded as preliminary as development/evaluation of production, components, products etc are still going on.

Short on bentonite

- Bentonite is a natural material extracted on many locations of the world, including Sweden.
- Bentonite mainly consists of clays in varying fine fractions. This means that the material generates dust, especially when it becomes dry. Great attention shall be directed partly towards making all designs dust resilient but also towards avoiding anything that may contribute to the generation of dust.
- The bentonite is delivered to the production plant in large batches. It is processed before it arrives at the pressing plant. This includes crushing, screening, adjustment of water content etc. Various tests are performed on each batch. The results are filed together with other process records.
- Bentonite storage, conveyors, filling equipment, machining etc are placed in areas separated from the pressing equipment. All equipment is designed with relevant dust protection.

Ingoing requirements, functions and components.

The following functions/components shall be included in the press system.

General

All included components and systems shall fulfil valid national and European norms and regulations.

This description mainly specifies functions. All equipment such as fasteners, cables, piping, hydraulic systems etc necessary for each function shall be included in a tender/delivery.

Working platforms, lifting equipment and other production appliances will be supplied by the purchaser unless specified below.

Press

- The press system shall contain one isostatic vessel, but be prepared for including a second vessel.
- Max isostatic pressure 100 MPa
- Inner diameter of isostatic vessel Ø2,450 mm
- Inner height of isostatic vessel 4,000 mm
- Press media Water
Any additives to the press media shall be specified by the supplier and approved by the purchaser.
- Cycle time: 120 min
- Proposed press cycle curve. Se appendix 2.
- The press shall be equipped with a system for charging the isostatic vessel in and out of the press.
- The press and isostatic vessel shall be designed so production, service and maintenance can be performed efficiently. Internal and external cleaning of the isostatic vessel shall be easily performed.

Hydraulic system

- The press system shall be delivered with a complete hydraulic system.
- The press cycle shall be easy to optimise regarding filling, pressing, holding time, unloading etc for best productivity. (Also see appendix 2.)
- The press system shall have sufficient capacity for filling/ emptying the isostatic vessel.
- The hydraulic system shall be equipped with a system for depressurising in case of an electric supply failure.
- The intention is to locate the hydraulic system in a space below floor level alongside the press alternatively in an enclosed space behind the press on the same level as the press.

Electrical and I&C systems

- The press shall have a programmable control system.
- The press system shall be prepared for logging every single press cycle. The data logging device is not included in the delivery.

Miscellaneous

- The isostatic vessel is loaded/ unloaded outside the press with an overhead crane.
- The isostatic tools (bags) are filled and stripped in areas separated from the pressing equipment.

Pressing tools

- The tools are currently under development/ testing.
- A set of tools consists of 1, 2 or 3 tools placed on top of each other.
- Depending on the product being produced the degree of filling of the isostatic vessel may vary.

Spare parts

- The supplier is requested to make a recommendation for spare parts to be held in store for production.

Maintenance and service

The supplier is requested give the following information:

- The weights and dimensions of components regarding lifting capacity for maintenance and service.
- Required carrying capacity for floors around and to and from the press.
- Requirement for media such as electrical power, cooling water, ventilation etc.
- Space requirements around the pressing equipment for maintenance and service.
- Space requirements for hydraulic and electrical installations.
- Special tools for maintenance and service.

Data test with cylindrical mould

Water content:

| Sample | mb g | m+mb g | ms+mb g | Water content % |
|----------------------|---------|-----------|------------|--------------------|
| 11-1 (centre_upper) | 0.794 | 13.998 | 12.717 | 10.744 |
| 11-2 (centre_middle) | 0.797 | 14.293 | 12.991 | 10.677 |
| 11-3 (centre_bottom) | 0.799 | 12.496 | 11.367 | 10.683 |
| 11-4 (outer_upper) | 0.800 | 24.292 | 21.999 | 10.817 |
| 11-5 (outer_middle) | 0.797 | 29.182 | 26.422 | 10.771 |
| 11-6 (outer_bottom) | 0.802 | 17.960 | 16.303 | 10.690 |
| 11_average | | | | 10.730 |
| 17-1 (centre_upper) | 0.794 | 22.455 | 19.425 | 16.263 |
| 17-2 (centre_middle) | 0.802 | 25.160 | 21.738 | 16.345 |
| 17-3 (centre_bottom) | 0.801 | 20.308 | 17.574 | 16.300 |
| 17-4 (outer_upper) | 0.803 | 34.088 | 29.377 | 16.487 |
| 17-5 (outer_middle) | 0.802 | 31.846 | 27.482 | 16.357 |
| 17-6 (outer_bottom) | 0.805 | 30.652 | 26.487 | 16.218 |
| 17_average | | | | 16.328 |
| 21-1 (centre_upper) | 0.803 | 24.067 | 20.143 | 20.290 |
| 21-2 (centre_middle) | 0.797 | 26.442 | 22.121 | 20.264 |
| 21-3 (centre_bottom) | 0.807 | 23.355 | 19.551 | 20.294 |
| 21-4 (outer_upper) | 0.802 | 35.742 | 29.787 | 20.545 |
| 21-5 (outer_middle) | 0.805 | 43.191 | 36.037 | 20.305 |
| 21-6 (outer_bottom) | 0.801 | 35.508 | 29.690 | 20.139 |
| 21_average | | | | 20.306 |

Density:

| Sample | Mass g | weight in paraffin g | mass string g | ρ_s g/cm ³ | ρ paraffin g/cm ³ | Volume cm ³ | r g/cm ³ |
|----------------------|-----------|----------------------------|---------------------|-------------------------------|--------------------------------------|---------------------------|--------------------------|
| 11-1 (centre_upper) | 24.318 | 13.932 | 0.014 | 2.780 | 0.8828 | 11.765 | 2.066 |
| 11-2 (centre_middle) | 25.129 | 14.494 | 0.015 | 2.780 | 0.8828 | 12.047 | 2.085 |
| 11-3 (centre_bottom) | 22.117 | 12.794 | 0.016 | 2.780 | 0.8828 | 10.561 | 2.093 |
| 11-4 (outer_upper) | 22.433 | 13.016 | 0.017 | 2.780 | 0.8828 | 10.667 | 2.101 |
| 11-5 (outer_middle) | 27.518 | 15.922 | 0.014 | 2.780 | 0.8828 | 13.135 | 2.094 |
| 11-6 (outer_bottom) | 19.106 | 11.038 | 0.014 | 2.780 | 0.8828 | 9.139 | 2.089 |
| 11_average | | | | | | | 2.088 |
| 17-1 (centre_upper) | 26.069 | 15.015 | 0.014 | 2.780 | 0.8828 | 12.522 | 2.081 |
| 17-2 (centre_middle) | 19.227 | 11.115 | 0.014 | 2.780 | 0.8828 | 9.189 | 2.091 |
| 17-3 (centre_bottom) | 19.220 | 11.137 | 0.016 | 2.780 | 0.8828 | 9.156 | 2.097 |
| 17-4 (outer_upper) | 32.735 | 19.070 | 0.016 | 2.780 | 0.8828 | 15.479 | 2.114 |
| 17-5 (outer_middle) | 36.633 | 21.189 | 0.016 | 2.780 | 0.8828 | 17.494 | 2.093 |
| 17-6 (outer_bottom) | 26.495 | 15.162 | 0.017 | 2.780 | 0.8828 | 12.838 | 2.063 |
| 17_average | | | | | | | 2.090 |
| 21-1 (centre_upper) | 29.864 | 17.115 | 0.016 | 2.780 | 0.8828 | 14.442 | 2.067 |
| 21-2 (centre_middle) | 28.015 | 16.124 | 0.017 | 2.780 | 0.8828 | 13.470 | 2.079 |
| 21-3 (centre_bottom) | 18.965 | 10.904 | 0.015 | 2.780 | 0.8828 | 9.131 | 2.075 |
| 21-4 (outer_upper) | 29.594 | 17.112 | 0.015 | 2.780 | 0.8828 | 14.139 | 2.092 |
| 21-5 (outer_middle) | 35.569 | 20.448 | 0.015 | 2.780 | 0.8828 | 17.128 | 2.076 |
| 21-6 (outer_bottom) | 43.434 | 24.869 | 0.016 | 2.780 | 0.8828 | 21.030 | 2.065 |
| 21_average | | | | | | | 2.076 |