

P-09-65

Site investigation SFR
Hydro Monitoring Program
Report for May 2008–August 2009

Göran Nyberg, Eva Wass
Geosigma AB

October 2009

Svensk Kärnbränslehantering AB
Swedish Nuclear Fuel
and Waste Management Co
Box 250, SE-101 24 Stockholm
Phone +46 8 459 84 00



ISSN 1651-4416

SKB P-09-65

ID 1245997

Site investigation SFR

Hydro Monitoring Program

Report for May 2008–August 2009

Göran Nyberg, Eva Wass
Geosigma AB

October 2009

Keywords: AP PF 400-07-051, AP SFR-08-031, Groundwater, Borehole, Instrumentation, Measurement methods, Monitoring, HMS, Forsmark, SFR, Project SFR extension.

This report concerns a study which was conducted for SKB. The conclusions and viewpoints presented in the report are those of the authors. SKB may draw modified conclusions, based on additional literature sources and/or expert opinions.

Data in SKB's database can be changed for different reasons. Minor changes in SKB's database will not necessarily result in a revised report. Data revisions may also be presented as supplements, available at www.skb.se.

A pdf version of this document can be downloaded from www.skb.se.

Abstract

SKB conducts bedrock investigations for a future extension of the final repository for low- and medium-level radioactive waste (SFR) at Forsmark within the Östhammar municipality. As a part of this investigation, hydrogeological monitoring is performed.

The objectives of the groundwater monitoring are, in a short-term perspective, to measure pressure responses during drilling, pumping and interference tests and also, in a long-term perspective, to create time series in order to increase the knowledge of the hydraulic conditions.

Data presented in this report are collected during the period of May 2008 until August 2009 and include groundwater levels in surface boreholes and groundwater pressure in boreholes situated in the tunnel.

The data collecting system in HMS (Hydro Monitoring System) consists of a measurement station (computer) that communicates with and collects data from a number of dataloggers. The computer is connected to the SKB Ethernet LAN. All data are collected by means of different transducers connected to different types of data loggers: Minitroll, LevelTroll and Datataker.

In order to calibrate registrations from the data loggers, manual levelling of all surface borehole sections is made, normally once every month. The logger data are converted to water levels using calibration constants. All collected data are quality checked once every three or four months. During this work, obviously erroneous data are omitted and calibration constants are corrected so that the monitored data comply with the manual levelling. At these occasions the status of the equipment is also checked and service might be initiated.

Diagrams of groundwater levels and groundwater pressure for the period of May 2008–August 2009 (one data point per section and twenty-four hours) are presented in Appendix 2. The original data are stored in the primary data base Sicada. The data in this data base may then be used for further analysis.

There are no nonconformities with respect to the activity plan or the method description.

Sammanfattning

SKB bedriver bergundersökningar inför en framtida utbyggnad av slutförvaret för radioaktivt driftavfall (SFR) vid Forsmark i Östhammars kommun. Som en del av denna undersökning utförs grundvattenmonitoring.

Hydrogeologisk monitoring ger underlag för beskrivning av grundvattnets tryck- och flödesfördelning i den undersökta bergvolymen. Syftet med monitoringen är i det korta perspektivet främst att mäta tryckresponser i samband med t ex borrhning, pump- och interferenstester. I det längre perspektivet ska datainsamlingen skapa tidsserier för att öka kunskapen om de hydrauliska förhållandena i ett längre tidsperspektiv.

Data presenterade i rapporten är insamlade under perioden maj 2008 till och med augusti 2009 och består av grundvattennivå i ytborrhål samt grundvattentryck i borrhål belägna i tunneln.

Datainsamlingssystemet i HMS (Hydro Monitoring System) består av en mätstation (dator) vilken kommunicerar med och samlar in data från ett antal dataloggrar. Datorn är förbunden med SKB:s nätverk. Alla data samlas in med hjälp av givare förbundna med olika typer av dataloggrar: Minitroll, LevelTroll och Datataker.

För att kunna kalibrera registreringarna från dataloggrarna utförs, vanligtvis en gång i månaden, manuell nivåregistrering (lodning) i alla sektioner i ytborrhålen. Loggerdata omvandlas till vattennivåer genom applicering av kalibreringskonstanter. Alla insamlade data kvalitetskontrolleras var tredje eller fjärde månad. Under detta arbete tas uppenbart felaktiga data bort och kalibreringskonstanterna korrigeras så att automatiskt registrerade data överensstämmer med manuella nivåregistreringar. Vid dessa tillfällen kontrolleras utrustningens status och service kan initieras.

Diagram över grundvattennivåer och grundvattentryck för perioden maj 2008–augusti 2009 (en datapunkt per sektion och 24 timmar) visas i Appendix 2. Originaldata lagras i primär databasen Sicada. Data från denna databas kan användas för vidare analyser.

Aktiviteten har utförts i överensstämmelse med aktivitetsplanen och metodbeskrivningen.

Contents

1	Introduction	7
2	Objective and scope	9
3	Equipment	11
3.1	Packer systems in surface and tunnel boreholes	11
3.2	Data collection system	13
4	Execution	15
4.1	General	15
4.2	Field work	15
4.3	Data handling	15
	4.3.1 Calibration method for surface boreholes	15
	4.3.2 Calibration method for tunnel boreholes	15
	4.3.3 Recording interval	15
4.4	Quality assurance	16
4.5	Nonconformities	16
5	Results	17
5.1	General	17
5.2	Groundwater levels and groundwater pressure	17
	5.2.1 General comments	17
	References	19
Appendix 1	Monitored borehole sections	21
Appendix 2	Groundwater Level and Groundwater Pressure	23

1 Introduction

SKB conducts bedrock investigations for a future extension of the final repository for low- and medium-level radioactive waste (SFR) at Forsmark within the Östhammar municipality. The extension project, “Projekt SFR-utbyggnad” (Project SFR Extension), consists of a number of sub-projects. One of those is the sub-project “Undersökningar” (Investigations) to which this activity belongs.

This document reports data collected within the hydro monitoring program, which is one of the activities performed within the site investigation at SFR. The work was carried out in accordance with activity plans SKB AP PF 400-07-051 and SKB AP SFR-08-031. Controlling documents for this activity are listed in Table 1-1. The activity plans and the method description are SKB’s internal controlling documents. The site investigation internal reports, Table 1-2, present the results from the quality check performed once every three/four months, see Section 4.4.

Data presented in this report were collected during May 2008–August 2009. Groundwater levels in surface boreholes and groundwater pressure in boreholes situated in the SFR tunnel are included in the data set.

The HMS (Hydro Monitoring System) is used to collect and store all data.

The original data are stored in the primary database Sicada and are traceable by the Activity Plan number.

Table 1-1. Controlling documents.

Activity Plans	Number	Version
Platsundersökning Forsmark	AP PF 400-07-051	1.0
Hydrologisk och hydrogeologisk monitoring 2008		
Projekt SFR-utbyggnad	AP SFR-08-031	1.0
Hydrologisk och hydrogeologisk monitoring 2009		
Method Descriptions	Number	Version
Metodbeskrivning för grundvattenmonitoring vid SKB:s platsundersökningar	SKB MD 360.002	1.0

Table 1-2. Monitoring reports.

Site investigation Internal Reports / Internal Project Reports (in Swedish)	Number
Platsprojekt Forsmark/SFR3	PIR-08-47
Kvalitetskontroll av yt- och grundvattenmonitoring Period februari–maj 2008	
Platsprojekt Forsmark/SFR3	PIR-08-48
Kvalitetskontroll av yt- och grundvattenmonitoring Period maj–september 2008	
Platsprojekt SFR	SKBdoc 1199213
Kvalitetsgranskning av yt- och grundvattenmonitoring Period september 2008–januari 2009	
Platsprojekt SFR	SKBdoc 1214318
Kvalitetsgranskning av yt- och grundvattenmonitoring inom SFR Period januari–maj 2009	
Platsprojekt SFR	SKBdoc 1217595
Kvalitetsgranskning av grundvattenmonitoring inom SFR Period maj–september 2009	

2 Objective and scope

The objectives of the hydrogeological monitoring are, in a short-term perspective, to measure pressure responses during drilling, pumping and interference tests and also, in a long-term perspective, to create time series in order to increase the knowledge of the hydraulic conditions.

Data collected within this activity are:

- groundwater level in surface boreholes (including core- and percussion-drilled boreholes in solid rock),
- groundwater pressure in boreholes situated in the SFR tunnel.

There are also some parameters that are used for monitoring the hardware performance and the environment in which the hardware is used. However, these parameters are not reported herein.

The following numbers of boreholes were monitored during the reporting period within the SFR site investigation:

- 6 core-drilled surface boreholes,
- 4 percussion-drilled surface boreholes,
- 14 core-drilled boreholes in the SFR tunnel.

The locations of the boreholes are shown in Figure 2-1. Coordinates of all boreholes in the reference system RT90 2.5 gon V 0:–15 and elevation at top of casing (TOC) are provided in Sicada.

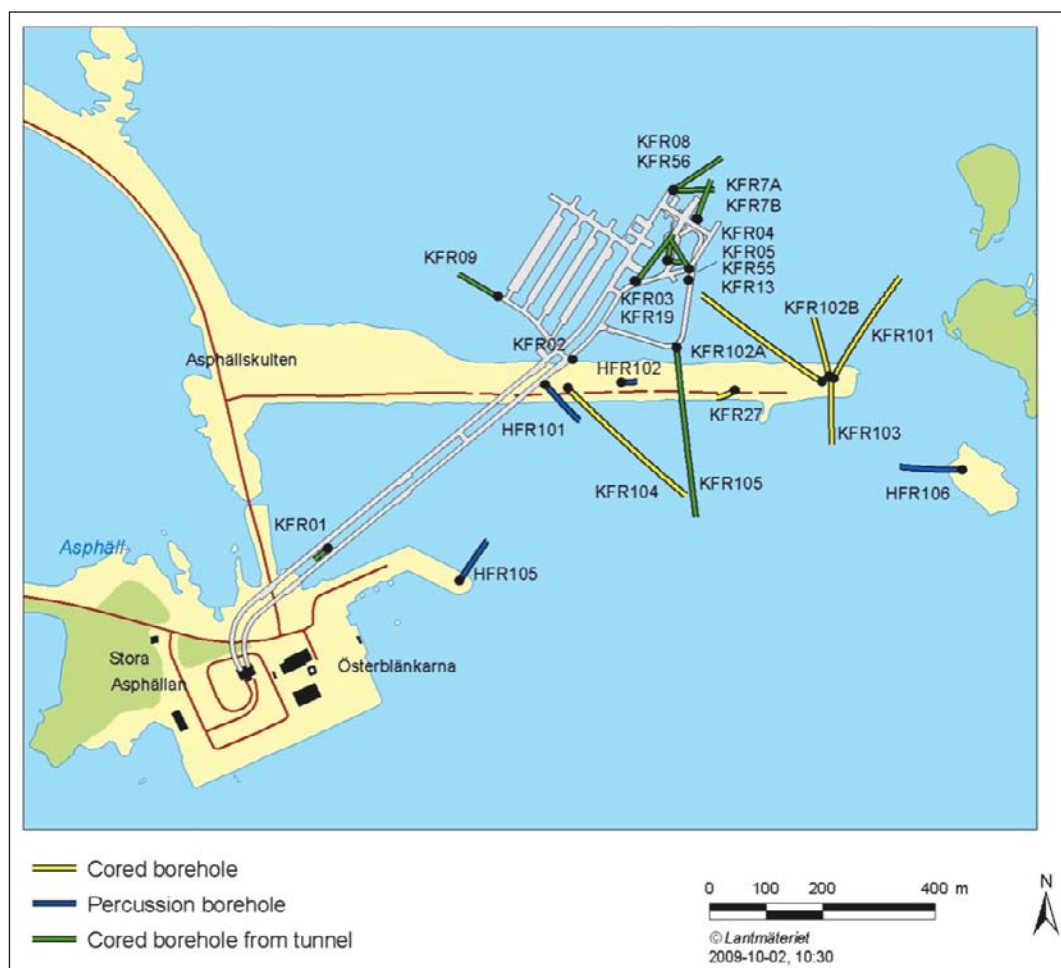

Figure 2-1. Overview of monitored boreholes at SFR.

3 Equipment

3.1 Packer systems in surface and tunnel boreholes

A drawing of the surface-based equipment used for percussion- and core-drilled boreholes is shown in Figure 3-1.

Drawings of the straddle-packer equipment for permanent instrumentation in core- and percussion-drilled surface boreholes are presented in Figure 3-2.

In open percussion and core boreholes, a transducer or data logger is submerged in the groundwater without any other equipment.

In Figure 3-3 a drawing of the instrumentation in tunnel boreholes is shown. The hydraulic packers are inflated by means of a gas bottle (N_2) and a water filled pressure vessel connected to the packer system, cf. Figure 3-4. The packed-off sections have hydraulic connection to the pressure transducers in the tunnel via polyamide bypass tubes through the packers.

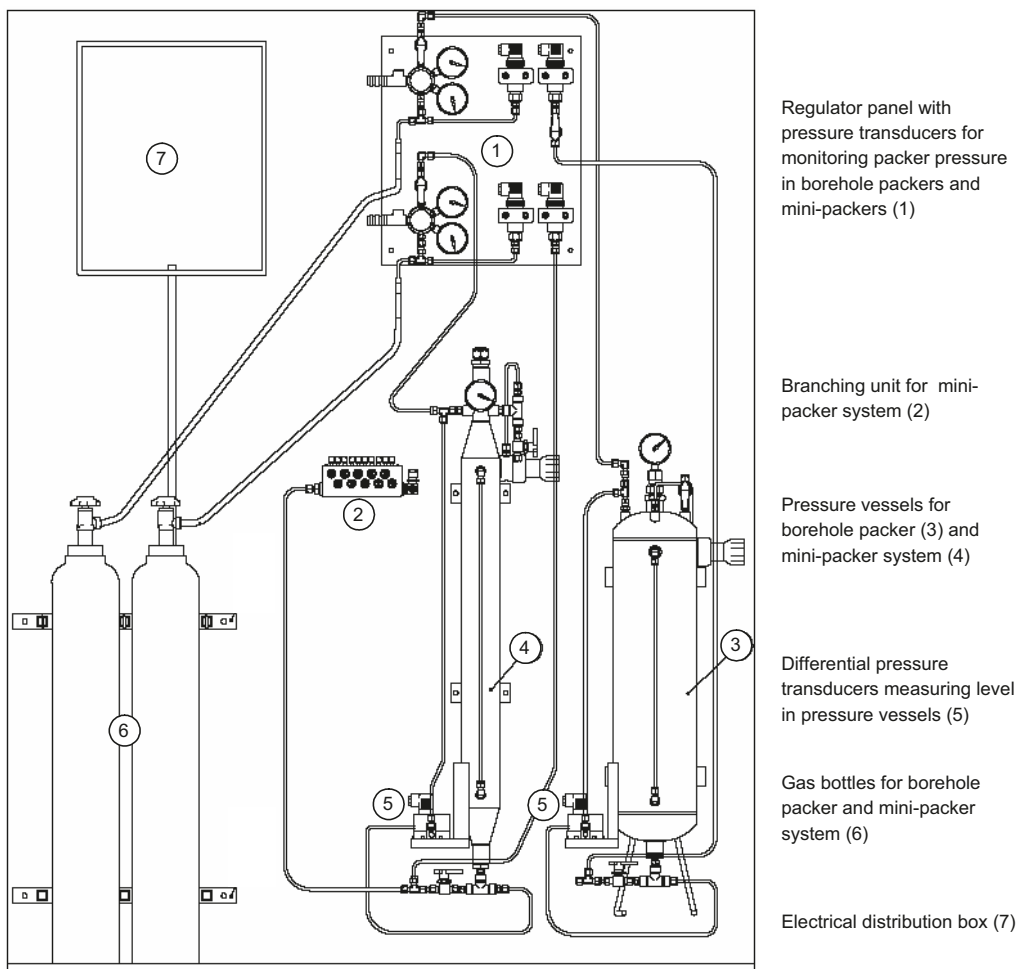

Figure 3-1. Example of ground surface equipment for percussion- and core-drilled boreholes.

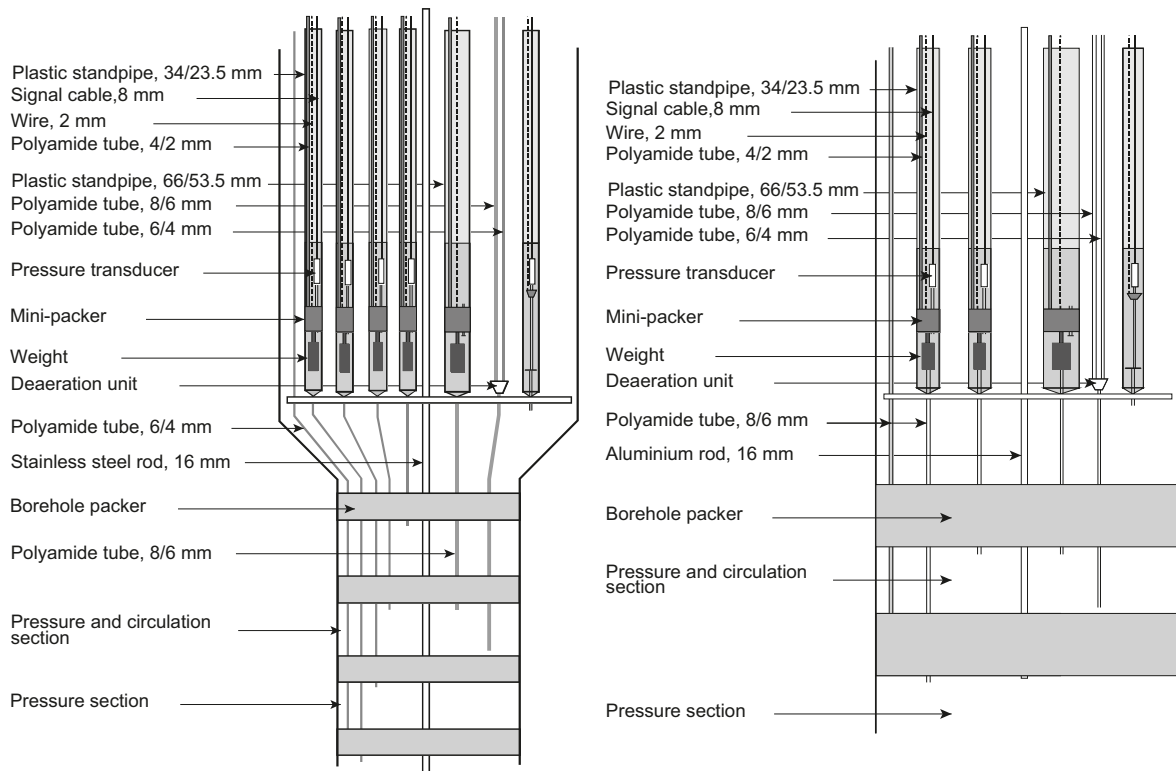

Figure 3-2. Example of permanent instrumentation in core-drilled (left) and percussion-drilled (right) surface boreholes supplied with circulation sections, i.e. a borehole section which enables circulation of the groundwater enclosed in the section as well as water sampling.

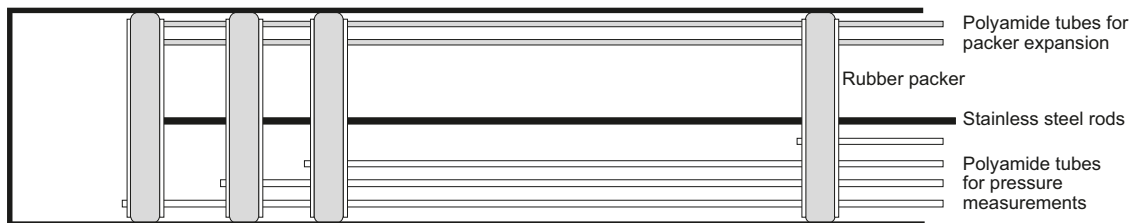

Figure 3-3. Example of instrumentation in tunnel boreholes with hydraulic packers.

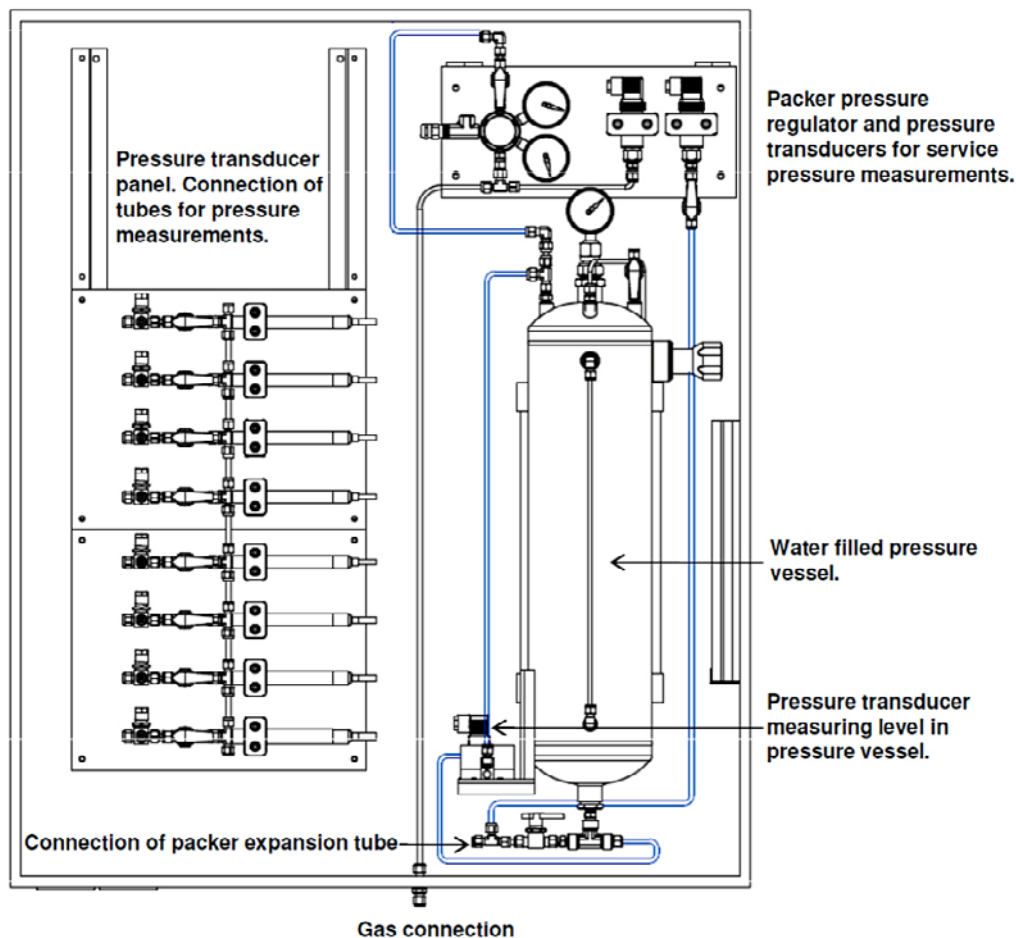

Figure 3-4. Example of accessory equipment for tunnel boreholes.

3.2 Data collection system

The data collection system, which is part of the Hydro Monitoring System (HMS), consists of a measurement station (computer) that collects data from a number of data sources, see Figure 3-5. The computer is connected to the SKB Ethernet LAN (Local Area Network).

All data are collected by means of pressure transducers connected to different types of data loggers or by manual levelling. The following data loggers are used:

Minitroll: a single-channel data logger of stand-alone type where the transducer is integrated in the logger. The logger is submerged in the groundwater and has the capacity to store 80,000 data.

Leveltroll: the successor to Minitroll, which is no longer manufactured. It is a logger that in most respects is equal to Minitroll, but has the capacity to store 350,000 data.

Datataker: a data logger connected on-line by means of radio or network. The logger has 42 channels and is used only for monitoring in percussion- and core-drilled boreholes.

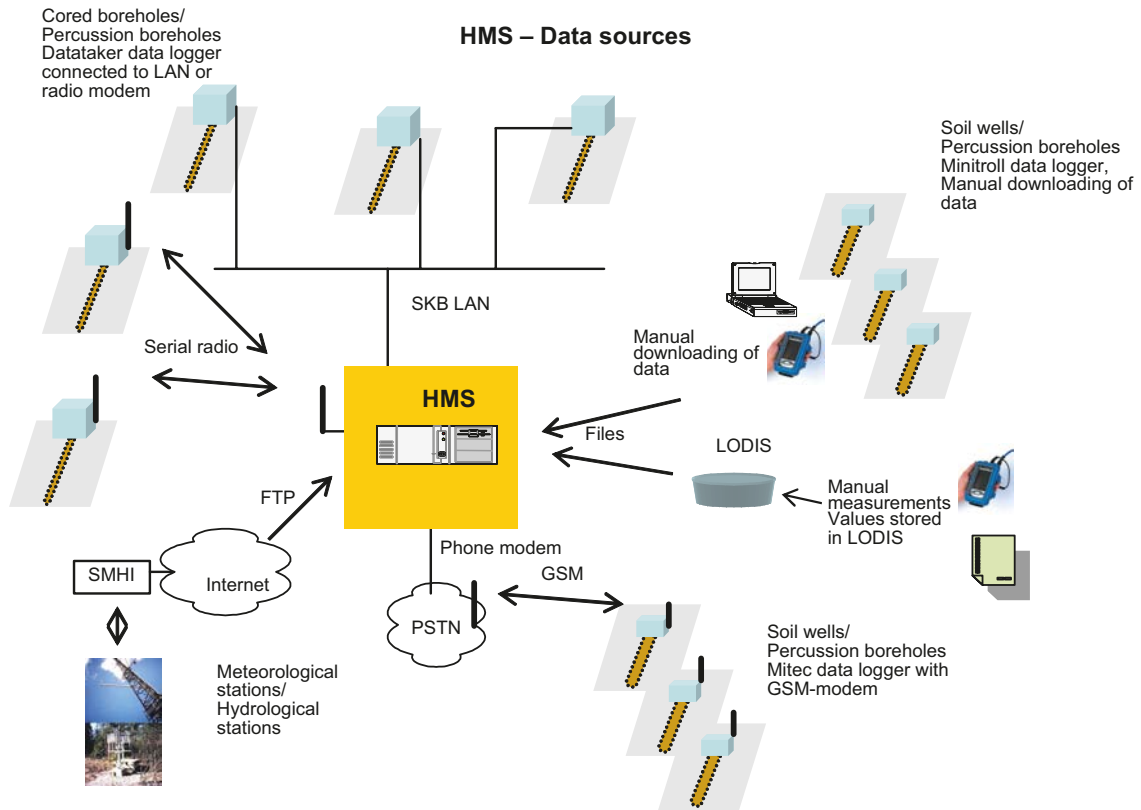

Figure 3-5. HMS data sources.

4 Execution

4.1 General

Data are collected to the measurement system, HMS, as described in Chapter 3.

The on-line system is designed to handle short interruptions in the communication. Data can be stored for at least a couple of hours in the loggers. All data are finally stored in the measurement station. Tape backup is made of all data.

Monitored data that have been quality assured are transferred quarterly to the site characterization database, Sicada.

4.2 Field work

Manual levelling is generally carried out once a month in the surface boreholes. At the same time, the equipment is checked and maintenance is performed.

All data from stand-alone type loggers are manually transferred to a portable PC and then transmitted to the measurement station, normally once every three months.

4.3 Data handling

4.3.1 Calibration method for surface boreholes

Manual levelling of all surface borehole sections is made, normally once every month, in order to calibrate the registrations from the data loggers.

The logger data from the surface boreholes are converted to water levels by means of a linear calibration equation. It is also necessary to subtract the air pressure since all transducers give the absolute pressure. Converted logger data are compared with results from manual levelling. If the two differ, calibration constants (offset) are adjusted until an acceptable agreement is obtained.

4.3.2 Calibration method for tunnel boreholes

A pressure reference system is installed in the SFR tunnel. It consists of two pressure tanks located at two different tunnel depths, generating one high and one low pressure of known magnitude. From these tanks, tubes are connected to each of the four measurement stations in the tunnel. At each station, a number of transducers are mounted on a panel where the tubes from the pressure reference system also are available to enable in situ calibration of the pressure transducers.

During calibration all transducers on the panel are connected to the reference system together with a mobile pressure transducer that is used for very accurate measurements of the high and the low pressure, respectively. From these measurements a linear calibration equation is calculated.

4.3.3 Recording interval

For data loggers connected on-line, as well as for stand-alone data loggers, measurements of the groundwater level are normally made with ten minutes intervals.

Measured values are not stored unless they differ from the previously stored value by more than 0.1 m (1 kPa) for percussion- and core-drilled boreholes. In addition to this, a value is stored every two hours.

4.4 Quality assurance

Once every week, an inspection of all collected data is performed. The purpose of this is to verify that all loggers are sending data and that all transducers are functioning.

Quarterly, all data collected are subject to a quality check. During this Q/A, obviously erroneous data are omitted and calibration constants are corrected so that the monitored data comply with the manual levelling data (see Section 4.3.1). At this occasion, the status of the equipment is also checked and service might be initiated.

4.5 Nonconformities

There are no nonconformities with respect to the activity plan or the method description.

Due to failures in the mechanical or electronic equipment, data are sometimes missing for longer or shorter periods. For more comments on the diagrams, see Monitoring Reports, Table 1-2.

When registrations are missing, manually levelled data, if available, are inserted.

In many boreholes, the groundwater level/pressure shows large and rapid variations. This is often due to activities such as drilling, pumping, water sampling, etc.

Packers may deflate due to leakage, which can be difficult to discover. If a section in a borehole suddenly shows a pressure that is close to the pressure in a neighbouring section, the reason might be deflated packers.

References

SKB's (Svensk Kärnbränslehantering AB) publications can be found at www.skb.se/publications.

Nyberg G, Wass E, 2006. Forsmark site investigation. Hydro monitoring program. Report for August 2005–September 2006. SKB P-06-263, Svensk Kärnbränslehantering AB.

Nyberg G, Wass E, 2007. Forsmark site investigation. Hydro monitoring program. Report for October 2006–March 2007. SKB P-07-113, Svensk Kärnbränslehantering AB.

Nyberg G, Wass E, 2008. Forsmark site investigation. Hydro monitoring program. Report for April 2007–April 2008. SKB P-08-72, Svensk Kärnbränslehantering AB.

Monitored borehole sections

Percussion- and core-drilled surface boreholes

Borehole	Section no	Start date	Stop date	Secup (mbl)*	Seclow (mbl)	Circ Section	Elevation Secup (m RHB70)	Elevation SecMid (m RHB70)
HFR101	1	2008-07-07		0.00	209.30		2.63	-94.21
HFR102	1	2008-05-14	2008-08-29	0.00	55.04		2.32	-21.04
	1	2008-09-01		28.00	55.04		-21.44	-32.82
	2	2008-09-01		0.00	27.00		2.32	-9.18
HFR105	1	2008-04-29	2008-08-20	0.00	200.50		3.27	-86.73
	1	2008-08-25		134.00	200.50		-117.50	-147.76
	2	2008-08-25		107.00	133.00		-92.88	-104.73
	3	2008-08-25		61.00	106.00		-51.17	-71.49
	4	2008-08-25		0.00	60.00		3.27	-23.42
HFR106	1	2009-07-10	2009-09-08	50.00	190.40		-40.87	-97.07
	2	2009-07-10	2009-09-08	0.00	49.00		1.27	-19.62
	1	2009-09-08		0.00	190.40		1.27	-77.42
KFR101	1	2008-07-04	2008-09-05	0.00	341.76		2.44	-135.72
	1	2008-09-18		279.50	341.76		-217.76	-240.15
	2	2008-09-18		91.00	278.50		-71.99	-146.51
	3	2008-09-18		0.00	90.00		2.44	-34.43
KFR102A	1	2008-12-19	2009-02-12	0.00	600.83		2.66	-270.46
	1	2009-03-02		444.00	600.83		-398.73	-468.17
	2	2009-03-02		423.00	443.00	x	-380.09	-388.97
	3	2009-03-02		255.00	422.00		-229.51	-304.68
	4	2009-03-02		220.00	254.00		-197.82	-213.23
	5	2009-03-02		214.00	219.00	x	-192.37	-194.64
	6	2009-03-02		185.00	213.00		-166.03	-178.76
	7	2009-03-02		103.00	184.00		-91.38	-128.28
	8	2009-03-02		0.00	102.00		2.66	-43.84
KFR102B	1	2008-08-20	2008-09-30	0.00	180.08		2.51	-70.52
	1	2008-10-15		146.00	180.08		-115.57	-129.24
	2	2008-10-15		128.00	145.00		-101.10	-107.94
	3	2008-10-15		0.00	127.00		2.51	-49.08
KFR103	1	2008-09-05	2008-10-21	0.00	200.50		2.43	-78.69
	1	2008-10-29		178.00	200.50		-140.93	-149.91
	2	2008-10-29		79.00	177.00		-61.58	-100.97
	3	2008-10-29		0.00	78.00		2.43	-29.24
KFR104	1	2008-09-29	2008-12-02	0.00	454.57		2.83	-179.24
	1	2008-12-11		333.00	454.57		-260.61	-306.47
	2	2008-12-11		98.00	332.00		-76.90	-169.65
	3	2008-12-11		0.00	97.00		2.83	-36.80
KFR27	1	2008-04-23	2008-06-02	0.00	146.50		2.87	-70.37
	1	2008-06-25	2008-08-12	0.00	148.51		2.87	-71.38
	1	2008-08-18	2008-09-23	110.00	148.51		-107.12	-126.38
	2	2008-08-18	2008-09-23	74.00	109.00		-71.12	-88.62
	3	2008-08-18	2008-09-23	0.00	73.00		2.87	-33.62
	1	2009-02-05		110.00	501.64		-107.12	-302.40
	2	2009-02-05		47.00	109.00		-44.12	-75.12
	3	2009-02-05		0.00	46.00		2.87	-20.13

* mbl = metres borehole length from TOC (Top Of Casing).

Core-drilled tunnel boreholes

Borehole	Section no	Start date	Stop date	Secup (mbl)*	Seclow (mbl)	Circ Section	Elevation Secup (m RHB70)	Elevation SecMid (m RHB70)
KFR01	1	1984-12-08	2008-03-13	44.50	62.30		-86.52	-94.23
	2	1984-12-08	2008-03-13	11.00	43.50		-57.51	-71.58
	1	2008-04-02		44.65	65.00		-86.65	-95.46
	2	2008-04-02		11.15	43.65		-57.64	-71.71
KFR02	1	1986-03-24	2008-03-11	137.00	170.33		-222.43	-239.09
	2	1986-03-24	2008-03-11	119.00	136.00		-204.43	-212.93
	3	1986-03-24	2008-03-11	81.00	118.00		-166.43	-184.93
	1	2008-03-17		137.24	170.30		-222.67	-239.20
	2	2008-03-17		119.24	136.24		-204.67	-213.17
	3	2008-03-17		81.24	118.24		-166.67	-185.17
	4	2008-03-17		43.24	80.24		-128.67	-147.17
KFR03	1	2008-02-29		81.16	106.00		-163.53	-175.95
	2	2008-02-29		57.16	80.16		-139.53	-151.03
	3	2008-02-29		45.16	56.16		-127.53	-133.03
	4	2008-02-29		5.16	44.16		-87.53	-107.03
KFR04	1	2008-03-11		84.09	101.00		-158.41	-166.58
	2	2008-03-11		44.09	83.09		-119.77	-138.61
	3	2008-03-11		28.09	43.09		-104.32	-111.56
	4	2008-03-11		5.09	27.09		-82.10	-92.73
KFR05	1	2008-03-11		97.15	131.00		-168.45	-184.36
	2	2008-03-11		80.15	96.15		-152.48	-160.00
	3	2008-03-11		57.15	79.15		-130.87	-141.20
	4	2008-03-11		12.15	56.15		-88.58	-109.25
KFR7A	1	2008-02-05		48.11	74.70		-133.97	-134.43
	2	2008-02-05		20.11	47.11		-132.99	-133.46
	3	2008-02-05		2.11	19.11		-132.36	-132.66
KFR7B	1	1985-10-02	2008-02-06	8.00	21.10		-140.97	-147.30
	1	2008-02-07		8.60	21.10		-141.55	-147.59
	2	2008-02-07		3.40	7.60		-136.53	-138.56
KFR08	1	2008-03-27		62.95	104.00		-91.51	-93.30
	2	2008-03-27		35.95	61.95		-89.15	-90.29
	3	2008-03-27		5.95	34.95		-86.54	-87.80
KFR09	1	1985-10-02		0.00	80.24		-77.44	-80.94
KFR13	1	2008-02-22		53.75	76.60		-177.09	-188.52
	2	2008-02-22		33.75	52.75		-157.09	-166.59
	3	2008-02-22		3.75	32.75		-127.09	-141.59
KFR19	1	2008-03-03		95.57	110.00		-58.02	-56.30
	2	2008-03-03		77.57	94.57		-62.32	-60.29
	3	2008-03-03		66.82	76.57		-64.88	-63.72
	4	2008-03-03		51.82	65.82		-68.46	-66.79
KFR55	1	2008-02-14		48.53	62.00		-134.83	-136.12
	2	2008-02-14		39.53	47.53		-133.12	-133.88
	3	2008-02-14		21.53	38.53		-129.68	-131.30
	4	2008-02-14		7.53	20.53		-127.01	-128.25
KFR56	1	2008-03-19		9.55	81.70		-80.36	-64.55
KFR105	1	2009-07-07		265.0	303.0		-150.44	-153.31
	2	2009-07-07		170.0	264.0		-135.40	-142.94
	3	2009-07-07		138.0	169.0		-130.20	-132.73
	4	2009-07-07		120.0	137.0		-127.22	-128.63
	5	2009-07-07		4.0	119.0		-107.53	-117.42

* mbl = metres borehole length from TOC (Top Of Casing).

Groundwater Level and Groundwater Pressure

