

## **Site investigation SFR**

# **Hydrochemical characterisation of groundwater in the SFR repository**

## **Sampling and analysis during 2010**

**Extended investigations in**

**KFR7A: 48.0 to 74.7 m**

**KFR08: 63.0 to 104.0 m and**

**KFR19: 95.6 to 110.0 m**

Kersti Nilsson, Geosigma AB

March 2011

**Svensk Kärnbränslehantering AB**

Swedish Nuclear Fuel  
and Waste Management Co

Box 250, SE-101 24 Stockholm  
Phone +46 8 459 84 00



## **Site investigation SFR**

# **Hydrochemical characterisation of groundwater in the SFR repository**

## **Sampling and analysis during 2010**

**Extended investigations in**

**KFR7A: 48.0 to 74.7 m**

**KFR08: 63.0 to 104.0 m and**

**KFR19: 95.6 to 110.0 m**

Kersti Nilsson, Geosigma AB

March 2011

*Keywords:* P-report, Forsmark, AP SFR-10-010, Core borehole, Groundwater, Measurements on-line, Water sampling, Sample series, Chemical analyses, Major constituents, Isotope determinations, Chlorine-36, Trace metals, Dissolved gas, Humic and fulvic acids, Project SFR extension.

This report concerns a study which was conducted for SKB. The conclusions and viewpoints presented in the report are those of the author. SKB may draw modified conclusions, based on additional literature sources and/or expert opinions.

Data in SKB's database can be changed for different reasons. Minor changes in SKB's database will not necessarily result in a revised report. Data revisions may also be presented as supplements, available at [www.skb.se](http://www.skb.se).

A pdf version of this document can be downloaded from [www.skb.se](http://www.skb.se).

## Abstract

This report presents chemistry data from the extended sampling in SFR, performed every five years. The extended sampling yielded groundwater chemistry data in accordance with SKB chemistry class 3, 4 and 5 and included all water bearing borehole sections.

Supplementary, more extensive, hydrochemical groundwater investigations were performed in three borehole sections: KFR7A:1 (48.0–74.7 m borehole length; 134.0–134.9 m.b.s.l.\*), KFR08:1 (63.0–104.0 m borehole length; 91.5–95.1 m.b.s.l.\*) and KFR19:1 (95.6–110.0 m borehole length; 58.2–54.5 m.b.s.l.\*) with a second purpose to supply important additional data to the SFR extension project. Samples for chemical analyses (major constituents, trace metals and isotopes) were collected in all three borehole sections and on-line measurements of pH, redox potential (Eh) and water temperature were also performed. The measurements were conducted in a flow through cell at the orifice of the boreholes. In addition, on-line measurements of electrical conductivity (EC) and dissolved oxygen were conducted in KFR19:1. Furthermore, enrichments of humic and fulvic acids for determination of  $\delta^{13}\text{C}$  and  $^{14}\text{C}$  in organic material were performed in all three sections and sampling for analyses of dissolved gas was performed in KFR08:1 and KFR19:1.

The three borehole sections with redox measurements showed stable water composition during the sampling periods. The chloride concentrations amounted to between 2,790 mg/L (KFR19:1) and 3,670 mg/L (KFR7A:1). All of the measured redox potentials (Eh) reached stable and consistent values (–153 mV in KFR7A:1, –156 mV in KFR08:1 and –168 mV in KFR19:1). All three borehole sections showed relatively high oxygen-18 values indicating a clearly marine origin of the groundwaters.

No major changes of the water chemistry in the four boreholes included in the annual hydrochemistry monitoring program have been noticed during 2010. A slow shift towards lower chloride concentrations can be noticed when data for a longer period are compared, even if the values from the last nine years seem to be more or less stable. The increasing admixture of Baltic seawater is most pronounced in borehole KFR7A, but is also present in KFR01 and KFR10. In KFR08, the chloride concentration exceeded the Baltic Sea by the start of the hydrochemistry monitoring program 1989. Since then the chloride concentration has decreased and at present it is comparable with the Baltic Sea.

\* metre below sea level.

## Sammanfattning

Rapporten redovisar kemidata från utökade vattenkemiska undersökningar i SFR, vilka utfördes var femte år. Den utökade provtagningen resulterade i grundvattenkemiska data enligt SKB:s kemiklasser 3, 4 och 5 och omfattade alla vattenförande borrhålssektioner.

Mer omfattande grundvattenundersökningar utfördes i tre borrhålssektioner i kärnborrhålen KFR7A:1 (48,0–74,7 m borrhålslängd; 134,0–134,9 m.u.h.), KFR08:1 (63,0–104,0 m borrhålslängd; 91,5–95,1 m.u.h.) och KFR19:1 (95,0–110,0 m borrhålslängd; 58,2–54,5 m.u.h.) med ett andra syfte att ge ytterligare viktiga data för SFR-utbyggnadsprojektet. Grundvattenprov för kemiska analyser (huvudkomponenter, spårmetaller och isotoper) togs ut från samtliga tre borrhålssektioner. On-line mätningar av pH, redox potential (Eh) och vattentemperatur utfördes också i alla tre borrhålssektionerna. Dessutom genomfördes on-line mätningar av elektrisk konduktivitet (EC) och löst syre i KFR19:1. Vidare gjordes uppkoncentrering av humus- och fulvosyror för bestämning av  $\delta^{13}\text{C}$  och  $^{14}\text{C}$  i organiskt material i alla tre borrhålssektionerna och prov för gasanalyser togs ut i KFR08:1 och KFR19:1.

De tre borrhålssektionerna med redoxmätningar visade stabila vattensammansättningar under provtagningsperioderna. Kloridkoncentrationerna uppgick till mellan 2 790 mg/L (KFR19:1) och 3 670 mg/L (KFR7A:1). Alla redoxpotentialmätningarna (Eh) nådde stabila och samstämmiga värden (–153 mV i KFR7A:1, –156 mV i KFR08:1 och –168 mV i KFR19:1). Grundvattnet i alla tre borrhålssektionerna visar relativt höga syre-18 värden vilket visar på ett tydligt marint ursprung.

Under 2010 har det inte skett några stora förändringar av vattensammansättningen i de borrhål som ingår i det årliga kontrollprogrammet. En långsam förskjutning mot lägre kloridhalter kan iaktas när analysdata jämförs över en längre tidsperiod, även om värdena för de senaste nio åren verkar ha mer eller mindre stabiliserat sig. Den ökande inblandningen av Östersjövatten är tydligast i borrhålet KFR7A men även i viss mån i KFR01 och KFR10. I KFR08 låg kloridhalten bara något över Östersjönivån vid inledningen av kontrollprogrammet 1989. Därefter har kloridhalten minskat och är för närvarande jämförbar med den i Östersjön.

# Contents

<b>1</b>	<b>Introduction</b>	7
<b>2</b>	<b>Objective and scope</b>	9
<b>3</b>	<b>Background</b>	11
3.1	Previous events and activities in boreholes with supplementary redox (Eh) investigations	11
<b>4</b>	<b>Equipment</b>	13
4.1	General	13
4.2	The measurement chamber and electrodes used in KFR7A:1 and KFR08:1	14
4.3	The mobile field laboratory used for measurements in KFR19:1	15
4.4	The measurement system and software	16
4.5	Equipment for enrichment of humic and fulvic acids	16
<b>5</b>	<b>Performance</b>	17
5.1	Water sampling, sample treatment and analyses	17
5.2	Overview of the field work procedure, supplementary redox (Eh) investigations	17
5.2.1	Enrichment of humic and fulvic acids	19
5.3	Nonconformities	19
<b>6</b>	<b>Data handling and interpretation</b>	21
6.1	Chemmac measurement data	21
6.1.1	Data file types and calculation software	21
6.1.2	Calculation and evaluation of redox potential and pH	21
6.2	Water analysis data	22
6.3	Data from special sampling methods	23
6.3.1	Dissolved gases	23
6.3.2	Enrichment of humic and fulvic acids	23
<b>7</b>	<b>Results</b>	25
7.1	Groundwater analyses	25
7.1.1	Basic analyses	25
7.1.2	Trace elements (rare earth metals and others)	25
7.1.3	Stable and radioactive isotopes	25
7.1.4	Dissolved gas	26
7.2	On-line measurements	26
7.2.1	Comparisons with previous redox (Eh) measurements	27
<b>8</b>	<b>Summary and discussion</b>	29
8.1	Water chemistry in SFR	29
8.2	Supplementary hydrochemical (redox; Eh) investigations	29
	<b>References</b>	31
<b>Appendix 1</b>	Sampling and analytical methods	33
<b>Appendix 2</b>	Flow rate during on-line measurements in KFR19, section 95.6–110.0 m	39
<b>Appendix 3</b>	Pressure registrations during measurements and sampling, HMS system	41
<b>Appendix 4</b>	On-line measurements in KFR7A, section 48.0–74.7 m	45
<b>Appendix 5</b>	On-line measurements in KFR08, section 63.0–104.0 m	47
<b>Appendix 6</b>	Chemmac measurements in KFR19, section 95.0–110.0 m	49
<b>Appendix 7</b>	Water Composition	51
<b>Appendix 8</b>	Water chemistry diagrams	63

# 1 Introduction

SKB is conducting investigations prior to a future enlargement of the SFR repository for low- and medium-level nuclear waste. The repository is situated close to the Forsmark nuclear plant in the Östhammar community. The reported activity is performed in the SFR facility and is conducted in order to supply data both to the running monitoring programme in the SFR and to the established geoscientific investigation program within the SFR extension project /SKB 2008/.

This document reports the results from sampling and analyses of groundwater in most of the boreholes drilled from the present SFR facility as well as on-line measurements of pH and redox (Eh) in three borehole sections (KFR7A:1 48.0–74.7 m borehole length, KFR08:1 63.0–104.0 m borehole length and KFR19:1 95.0–110.0 m borehole length). The work was carried out in accordance with activity plan AP SFR-10-010. Controlling documents for performing this activity are listed in Table 1-1. Both activity plan and method descriptions are SKB's internal controlling documents.

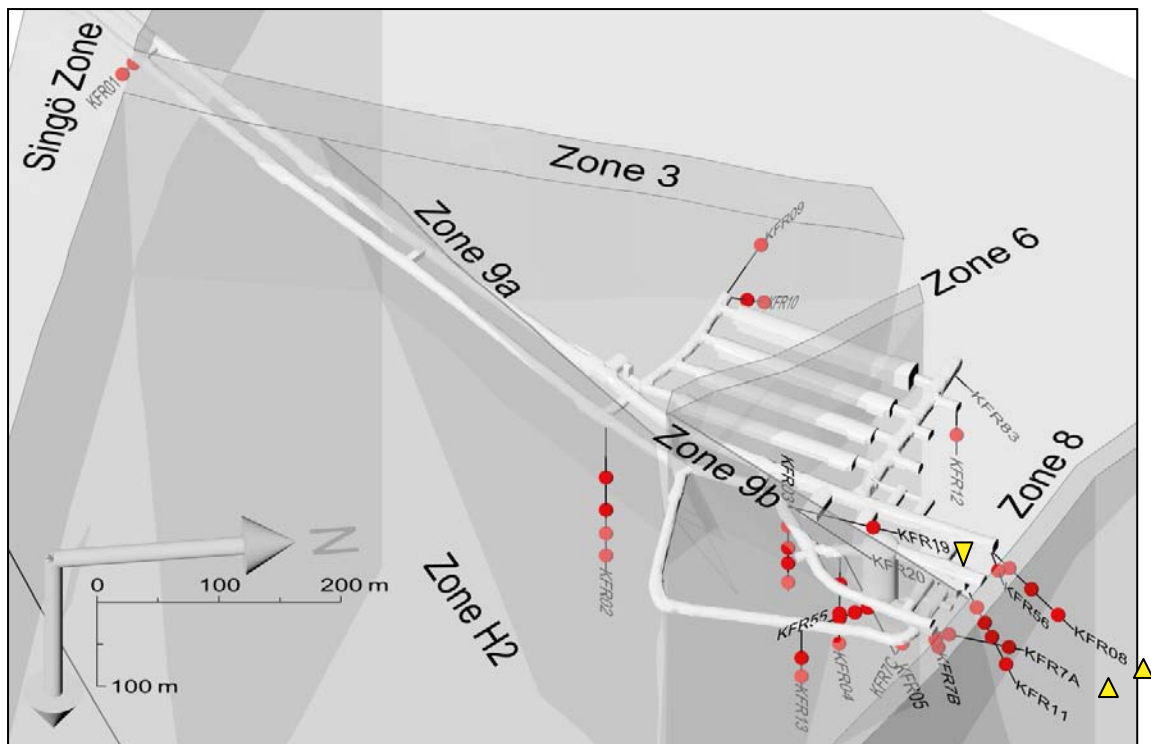
Original data from the reported activity are stored in the primary database Sicada and traceable in Sicada by the activity plan number (AP SFR-10-010). Only data in databases are accepted for further interpretation and modelling. The data presented in this report are regarded as copies of the original data. Data in the database may be revised, if needed. However, such revision of the database will not necessarily result in a revision of this report although the normal procedure is that major data revisions entail a reversion of the P-report. Minor revisions are normally presented as supplements, available at [www.skb.se](http://www.skb.se).

**Table 1-1. Controlling documents for performance of the activity.**

<b>Activity plan</b>	<b>Number</b>	<b>Version</b>
Redoxmätningar i tre borrhål/borrhålssektioner i SFR	AP SFR-10-010	1.0
<b>Method descriptions</b>	<b>Number</b>	<b>Version</b>
Metodbeskrivning för vattenprovtagning och analys i instrumenterade borrhål (under framtagning)	SKB MD 425.001	In prep.
Mätsystembeskrivning – Handhavandedel; System för hydrologisk och meteorologisk datainsamling. Vattenprovtagning och utspädningsmätning i observationshål.	SKB MD 368.010	1.0
Metodbeskrivning för fullständig kemikaraktisering med mobilt fältlaboratorium	SKB MD 430.017	2.0
Prototype mätutrustning	SKB TD-09-04	1.0
Mobila kemienheter	SKB MD 434.007	1.0
Dataapplikation till Chemmac mätsystem	SKB MD 433.018	1.0
Uppkoncentrering av humus- och fulvosyror för kol-13 och kol-14 bestämningar	SKB MD 431.044	1.0
Provtagning och analys- kemilaboratorium	SKB 452.001-019	–

The field work was performed during October to December 2010 and consisted of water sampling in 31 borehole sections in SFR, according to the extended sampling program performed every five years in SFR. In addition supplementary hydrochemical (redox; Eh) investigations were performed, where three consecutive water samples were taken from each borehole section (KFR7A:1, KFR08:1 and KFR19:1) together with on-line measurements of pH, redox potential (Eh) and temperature in all three sections and electrical conductivity (EC) and dissolved oxygen in KFR19:1.

The SFR tunnel system with borehole locations is shown in Figure 1-1, and the three boreholes with redox measurements are shown with yellow triangles. Their borehole lengths and transmissivity values are listed in Table 1-2. The approximately 75 m long borehole KFR7A was drilled towards north from the end of the lower construction tunnel in SFR with an almost horizontal inclination. Borehole KFR08 (c 104 m long) was drilled towards northeast from the end of the service tunnel in



**Figure 1-1.** 3-D map with borehole locations in relation to the SFR tunnel system and major deformation zones (geological model version 0.1, SFR-extension project). Borehole sections with chemistry data are marked with red filled circles. The extensively investigated boreholes (KFR7A, KFR08 and KFR19) are marked with yellow triangles.

**Table 1-2. Borehole sections for redox (Eh) measurements (borehole length, meters below sea level and hydraulic transmissivity).**

Section	Borehole length (m)	m.b.s.l.	T (m <sup>2</sup> /s) *
KFR7A:1	48.0–74.7	134.0–134.9	8.0E-05
KFR08:1	63.0–104.0	91.5–95.1	6.2E-06
KFR19:1	95.6–110.0	58.2–54.5	2.9E-09

\*/Jönsson S 2011/.

SFR with an almost horizontal inclination and borehole KFR19 (c 110 m long) was drilled towards northeast from the opening of the upper construction tunnel in SFR with a slightly upwards inclination. The drilling of the boreholes was performed from 1984 to 1986.

## 2 Objective and scope

A monitoring program was established in 1989 for the operative stage in SFR. Within the program, the groundwater composition is regularly checked in one section each in four boreholes. During the first years, water samples for chemical analysis were taken twice every year. After a revision of the monitoring program in 1996, the sampling frequency was reduced to once every year but with more extensive sampling in all borehole sections yielding water every five years. The analytical protocol for the latter samples includes sampling and analyses according to SKB chemistry class 3 and 5.

The importance of a relevant description of the redox system has been emphasized from a safety assessment perspective in connection with the external review of the preliminary site descriptive model for the SFR area /Nilsson et al. 2010/. After completion of the investigations within the SFR extension project, interpretation of available data did not exclude the possibility that Eh had increased to oxic values since the 1980's due to the influence of the SFR depository. Existing redox data from measurements in groundwater were limited to two borehole sections within the SFR extension project and to three borehole sections from previous investigations in SFR. Some of these data were considered uncertain. To complement the amount of redox data, and in order to possibly verify that the oxic values are artefacts and that the reduced conditions prevail also today, additional redox measurements have been performed during October to December 2010. Two of the investigated borehole sections were selected in order to obtain redox data from the type of groundwater that is considered most likely to be oxic due to the drawdown around the SFR depository.

The analytical protocol for the supplementary investigations (redox; Eh) includes sampling and analyses according to SKB chemistry class 4 and 5 and was performed in all three borehole sections (KFR7A, 48.0 to 74.7 m; KFR08, 63.0 to 104.0 m and KFR19, 95.6 to 110.0 m borehole length). The analyses of the water samples include major constituents, minor constituents, trace elements and stable as well as radioactive isotopes.

In KFR19:1, the on-line measurements include pH, redox potential (Eh), electrical conductivity (EC) dissolved oxygen and temperature. In KFR7A:1 and KFR08:1, pH, redox potential (Eh) and temperature measurements were performed. Furthermore, enrichments of humic and fulvic acids for analysis of  $\delta^{13}\text{C}$  and  $^{14}\text{C}$  in organic constituents were performed in all three borehole sections. In KFR08:1 and KFR19:1, special sampling was carried out for analysis of dissolved gas. Information about borehole lengths is given in Table 1-2.



## 3 Background

### 3.1 Previous events and activities in boreholes with supplementary redox (Eh) investigations

The boreholes/borehole sections selected for redox measurements included KFR08:1, KFR7A:1 and KFR19:1.

The dates for core drilling and re-installation of packers are listed in Table 3-1. The packer system was replaced during 2008, and in connection to this the borehole sections were left open for some periods. Continuous pressure registrations have been made after the installation of new packers. Annual sampling for hydrochemical monitoring has been carried out in four selected borehole sections (KFR01:1, KFR10, KFR08:1 and KFR7A:1) since 1989 (twice a year until 1995). A more extensive analytical program has been carried out every five years (1995, 2000, 2006 and 2010) including all water yielding borehole sections, also KFR19:1.

**Table 3-1. Activities performed in the investigated boreholes prior to the hydrochemical characterisation.**

Borehole	Core drilling Date of completion*	Release of old packers	Re-installation of new packers
KFR7A**	1985-08-25	2008-01-04	2008-02-05
KFR08**	1986-01-09	2008-03-26	2008-03-27
KFR19***	1985-12-17	2008-02-21	2008-02-27

\* From Sicada.

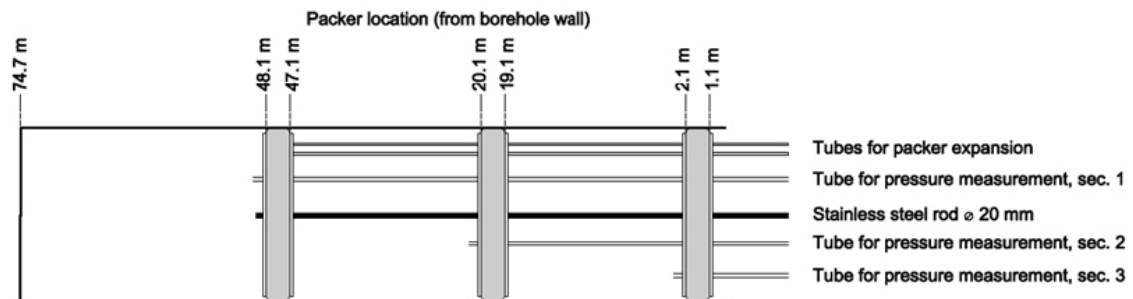
\*\* Annual sampling.

\*\*\* Sampling every five years.

## 4 Equipment

### 4.1 General

The boreholes are drilled from the tunnel. Hence, no pumping or other equipment is required for water sampling since the pressure in the rock is higher than at the tunnel wall and water can be discharged by opening a valve on the tubing connected to the sampled sections. All borehole sections are sealed off by inflated packers. The instrumentation in a core-drilled borehole is illustrated in Figure 4-1. The boreholes KFR7A, KFR08 and KFR19 for redox (Eh) measurements contain three, three and four borehole sections each, respectively. The supplementary investigations have been performed in the bottom section in each of the three boreholes. However, the surface Chemmac (Section 4.3) and the measurement chamber (Section 4.2). The measurement chamber and electrodes used in KFR7A:1 and KFR08:1) for on-line measurements were connected immediately to the line for pressure measurements (made of polyamide PA11 instead of the teflonized tubes intended for water sampling), see Figure 4-2.



**Figure 4-1.** Schematic outline of the instrumentation in a core-drilled borehole from the tunnel. The borehole lengths given refer to borehole KFR7A.



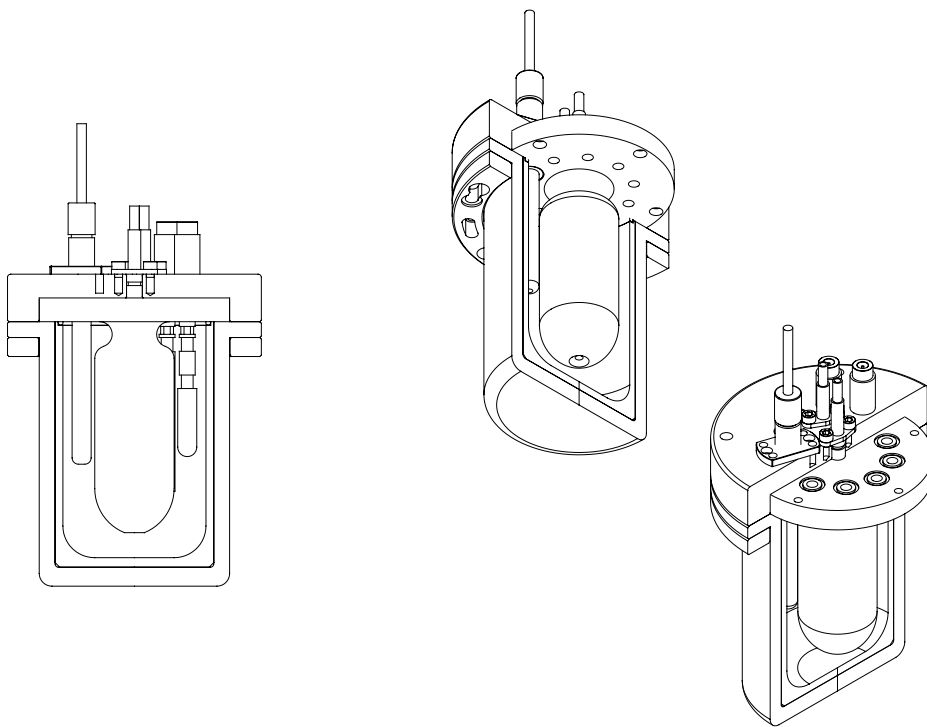
**Figure 4-2.** Connection between the borehole line used for pressure measurements and the surface Chemmac used in KFR19:1. Such a direct connection reduces the number of fittings and thereby minimizes the risk of external oxygen intrusion by diffusion or leakage. The line used is the one in the lower bundle marked with black tape.

This arrangement was preferred as it reduces the number of fittings, which may be a considerable potential source of error when redox measurements are performed. The length of the tubing from the borehole surface to the measurement chamber was c 10 m in all three borehole sections.

## 4.2 The measurement chamber and electrodes used in KFR7A:1 and KFR08:1

Figure 4-3 shows an outline of the measurement chamber containing two glass electrodes, a gold electrode (Au), a platinum electrode (Pt), a glassy-carbon electrode and a reference electrode (Ag, AgCl). The glass and reference electrodes are specially designed for measurements at high pressure. Figure 4-4 shows a photo of the measurement chamber.

The equipment was connected to the line for pressure measurements (made of polyamide PA11 instead of the teflonized tubes intended for water sampling).



**Figure 4-3.** Outline of the measurement chamber with electrodes, used in KFR7A:1 and KFR08:1.



*Figure 4-4. The measurement chamber, used in borehole sections KFR7A:1 and KFR08:1.*

### **4.3 The mobile field laboratory used for measurements in KFR19:1**

The mobile field laboratories used by SKB for water sampling and down-hole measurements consist of several units. The system is described in the SKB internal controlling documents SKB MD 434.004, 434.007 and SKB MD 433.018 (Mätsystembeskrivningar för mobil kemienhet allmän del, mobil ytChemmac och dataapplikation). Since the down-hole equipment is not suitable in these tunnel borehole cases, only the computer unit MYC 4 including the surface Chemmac measurement system and the laboratory unit L3 were employed for measurements, sampling and analytical work. The laboratory unit L3 was located close to the Forsmark core-mapping facility and not at the drill site in the SFR tunnel.

The surface Chemmac, see Figure 4-5, includes the probe for oxygen measurements, the conductivity cell and the temperature sensor. Furthermore, two glass electrodes, three redox electrodes (glassy carbon, platinum, gold) and a reference electrode of type Ag/AgCl are used for pH and redox potential measurements, respectively. The flow rate is also measured by the surface Chemmac.





*Figure 4-5. The surface Chemmac used in borehole section KFR19:1.*

#### **4.4 The measurement system and software**

The measurement system associated to the measurement chamber (Figure 4-4) consists of a voltmeter, amplifier and software designed by Research Electronics AB. The software is a simple data logging function, where the electrode potentials are given in milliVolts (mV).

The original raw data files obtained from this measurement system are not of the same type as the ones obtained from Chemmac measurements. The files were adapted (some nomenclature was changed and some help files were added) in order to be compatible with the calculation software (Hilda) normally used for the calculations of Chemmac measurement data.

#### **4.5 Equipment for enrichment of humic and fulvic acids**

Enrichment of humic and fulvic acids is conducted in order to collect enough material to determine  $\delta^{13}\text{C}$  and pMC (percent Modern Carbon) in organic constituents in the groundwater. The equipment for enrichment includes a porous column filled with an anion exchanger (DEAE-cellulose) and a textile filter with a well-defined pore size. The textile filter is placed inside the column in order to prevent the ion exchange resin from diffusing through the column. The equipment and performance is described in SKB MD 431.044 (Mätssystembeskrivning för uppkoncentrering av humus- och fulvosyror, SKB internal controlling document). Since the ion exchange resin in the column creates a counter-pressure, which disturbs the water flow through the surface Chemmac, a pump was used for pumping a portion of the outlet water through the column (approximately 2.4 L/hour).

## 5 Performance

### 5.1 Water sampling, sample treatment and analyses

Within the SFR monitoring programme the discharge of groundwater was started by opening the valves connected to the tubings and at least three borehole section volumes were discharged prior to sampling. Some sample portions are analysed immediately (pH, electrical conductivity, chloride, alkalinity, ammonium, ferrous and total iron) while other samples are sent to laboratories or stored in a refrigerator or freezer for later analyses.

Sample portions intended for analysis of major constituents, iron (by spectrophotometry), DOC and nutrient salts were filtered. During the entire sampling procedure, laboratory gloves were used to minimise the risk of contamination. Sampling was performed according to SKB class 3 and 5 according to the monitoring program and SKB class 4 (reduced) and 5 within the supplementary hydrochemical investigation. Class 5 is the most extensive one. An overview of sample treatment and analysis methods is given Appendix 1. The routines are applicable independently of sampling method or type of sampling object.

Within the monitoring programme, filtration of sample portions was performed on-line (if possible depending on flow rate), by connecting disposable 0.4 µm membrane filters in filter holders directly to the water outlet.

The groundwater from the borehole sections KFR7A:1 and KFR08:1 was led into the container where the measurement chamber was located while water from borehole section KFR19:1 was led into the MYC unit where the surface Chemmac was located. Water sampling and sample filtration was carried out inside the container at KFR7A and KFR08, but outside the MYC unit at KFR19.

### 5.2 Overview of the field work procedure, supplementary redox (Eh) investigations

Events during the measurement periods for the boreholes subject to redox (Eh) measurements (when water was flowing from the respective borehole section), including flow rate adjustments and discharged water volumes, are shown in Tables 5-1 to 5-3. After the line for pressure measurements was connected to the measurement cell, six tube volumes of water were removed before the first sample was collected, from each borehole section. The second sample was taken by around the middle of the period and the third one by the end of the measurement period.

The flow rates often tended to decrease during the measurement periods. Hence, one flow rate adjustment was made in borehole section KFR7A:1. The flow rates were kept in the range of c 70 to 180 mL/min in KFR7A:1, 95 to 120 mL/min in KFR08:1 and 65 to 100 mL/min in KFR19:1. The manually measured flow rates in KFR7A:1 and KFR08:1 are given in Table 5-1 and Table 5-2, and the on-line flow rate measurement in KFR19:1 is shown in Appendix 2.

Calibration of the pH and redox electrodes as well as the electrical conductivity and oxygen sensors in the surface Chemmac was conducted when the water from the borehole section reached the measurement unit and again at the end of each measurement period. The measurement period was c 5 weeks in KFR7A:1, c 3 weeks in KFR08:1 and c 7 weeks in KFR19:1.

The pressure responses in surrounding borehole sections caused by sampling in the target sections are shown in Appendix 3. The pressure responses indicate that the borehole sections in KFR7A, KFR7B and KFR08 have insignificant hydraulic connections between each other. The chemical composition of the samples should therefore be unaffected by other borehole sections. For KFR19, however a pressure response in KFR19:2 can be seen.

**Table 5-1. Events during the sampling period in KFR7A (48.0–74.7 m).**

Date	Event	SKB sample no.	Discharged volume (m <sup>3</sup> )	Flow rate (mL/min)
101027	Calibration of measurement equipment			
101027 14:17	Valve opening			73
101027	Start of measurements			104
101029	Water sampling SKB, class 4 (reduced)	16879	0.15	117
101102	Humic and fulvic acids: enrichment start		0.32	114
101103	Flow rate increase			to 178
101105	Flow rate adjustment			to 125
101112	Water sampling SKB, class 4 (reduced)	16882	1.92	136
101130	Humic and fulvic acids: enrichment stop			108
101130	Water sampling SKB, class 5+	16917	4.72	
101201	End of measurements			
101201 10:08	Valve closing			
101201	Calibration of measurement equipment			
			<b>4.73</b>	<b>73–180</b>

**Table 5-2. Events during the sampling/measurement period in KFR08 (63.0–104.0 m).**

Date	Event	SKB sample no.	Discharged volume (m <sup>3</sup> )	Flow rate (mL/min)
101202–101203	Calibration of measurement equipment			
101203 11:13	Valve opening			
101203	Start of measurements			118
101207	Water sampling SKB, class 4 (reduced)	16938	0.61	107
101209	Power failure			106
101210	Humic and fulvic acids: enrichment start		1.05	95
101214	Inspection			103
101216	Water sampling SKB, class 4 (reduced)	16834	1.94	104
101220	Water sampling SKB, class 5+	16843	2.01	118
101221	Humic and fulvic acids: enrichment stop			
101221	Sampling of dissolved gases			
101221	End of measurements			
101221 12:45	Valve closing			
101221	Calibration of measurement equipment			
			<b>2.20</b>	<b>95–120</b>

**Table 5-3. Events during the sampling period in KFR19 (95.6–110.0 m).**

Date	Event	SKB sample no.	Discharged volume (m <sup>3</sup> )	Flow rate (mL/min)
101026	Calibration of Chemmac equipment			
101026 13:43	Valve opening			
	Start of Chemmac measurements			
101028	Water sampling SKB, class 4 (reduced)	16878	0.25	80
101029–	Power failure, no collection of data			
101102	Batteries re-loaded, restart of measurements			
101102	Humic and fulvic acids: enrichment start		0.40	82
101102–101105	No data collection due to loss of contact with the computer			92
101109	Water sampling SKB class 4 (reduced)	16892	1.12	
101207	Water sampling SKB class 5+	16937	3.91	65
101208	Sampling of dissolved gases			
	End of Chemmac measurements			
101208 14:42	Valve closing			
101208	Calibration of measurement equipment			
			<b>4.01</b>	<b>64–100</b>

### 5.2.1 Enrichment of humic and fulvic acids

Enrichment of humic and fulvic acids was conducted in order to collect enough material to determine  $\delta^{13}\text{C}$  and pMC in organic constituents in the groundwater. The method is described in SKB MD 431.044 (Mätsystembeskrivning för uppkoncentrering av humus- och fulvosyror). The enrichment method entails collection of organic acids on an ion exchanger, eluation of the resin and evaporation of the resulting solution. In addition to organic material, the residue also contains sodium hydroxide from the eluation. The sample is acidified in order to prevent the formation of carbon dioxide. Estimates of total duration and water volume through the ion exchanger are given in Table 5-4.

**Table 5-4. Enrichment time and water volume through the ion exchanger.**

Borehole section [m]	Duration of enrichment [days]	Volume through ion exchanger [L]
KFR7A:1	22	1,100
KFR08:1	10	812
KFR19:1	33	2,900

### 5.3 Nonconformities

The hydrochemical sampling program in SFR and the hydrochemical characterisations in KFR7A:1, KFR08:1 and KFR19:1 have been conducted according to the SKB internal controlling document AP SFR-10-010 with the following deviations and remarks:

- Measurement data from borehole section KFR19:1 was lost during the period 2010-10-29 15:04 until 2010-11-02 15:50 because of a power failure.
- Measurement data from borehole section KFR08:1 was lost from 2010-12-07 10:02 to 2010-12-09 08:20 due to a power failure.
- The measurement periods in the extensively investigated borehole sections were planned to be three weeks, but since redox potential (Eh) data were unstable as well as diverging among the three electrodes, the measurement periods were extended to 5 weeks in KFR7A:1 and to 7 weeks in KFR19:1.
- No gas sample was collected in KFR7A:1 due to time constraints.
- No water sampling was performed in borehole section KFR19:4 (51.8 to 65.8 m borehole length) due to of lack of water flow.



## 6 Data handling and interpretation

### 6.1 Chemmac measurement data

The processing of Chemmac data is described in SKB MD 434.007-02 (Mätssystembeskrivning för Chemmac mätsystem, SKB internal controlling document, in progress).

#### 6.1.1 Data file types and calculation software

The on-line measurements produce the following types of raw data files:

- Calibration files from calibration measurements (\*.CRB) and corresponding comment files (\*.CI). The files are used for calculation of calibration constants (pH and Eh) and the calibration factor (electrical conductivity). For surface Chemmac ten \*.CRB and ten \*.CI files are produced.
- Raw data files containing the logged measurement sequences (\*K.MRB) and corresponding comments (\*.MI). The logged voltage values need to be converted to pH and Eh values (also in mV) using the calibration constants obtained from calibration.
- Measurement file including equipment and environment parameters (\*O.MRB), such as atmospheric pressure and outdoor temperature.

The original raw data files listed above are stored in the Sicada file archive. Furthermore, the files are re-calculated and evaluated to obtain values of pH and redox potential and to correct the electrical conductivity values using the calculation software Hilda. The resulting files containing calculated and evaluated values as well as comments on the performance are:

- A file *\*constants.mio* containing all the calculated calibration constants (one constant for each electrode in each buffer solution). The file is stored in the Sicada file archive and is useful in order to follow the development of single electrodes.
- A file *\*measurements.mio* containing the calculated and evaluated measurement values (pH, redox potential, electrical conductivity and water temperature). The data from the file are exported to the data tables “redox” and “ph\_cond” in Sicada. As the file also contains some measured parameters that are not included in the tables mentioned above (e.g. pressure registrations) the complete file is also stored in the Sicada file archive.
- A file *\*comments.mio* containing comments on the field work and the calculation/evaluation. The comments in the file are imported as activity comments in Sicada.

#### 6.1.2 Calculation and evaluation of redox potential and pH

The registrations from the redox and the pH electrodes are logged each hour during a measurement period of approximately two weeks and a calibration is performed before and after the measurement period. The treatment of the raw data includes the following steps:

- Calculation and choice of calibration constants.
- Calculation of one pH and one redox potential sequence for each electrode (i.e. three redox electrodes and two pH electrodes).
- Determination of representative pH and redox potential values as well as estimated measurement uncertainties for the investigated borehole section.

One calibration constant is selected for each electrode using one of the following alternatives:

- Case 1: Calculation of the average calibration constant value and the standard deviation. The initial and the final calibration measurements results in four constants for each redox electrode (in pH 4 and pH 7 buffer solutions) and six constants for each pH electrode (in pH 4, 7 and 10 buffer solutions).

- Case 2: The calibration constant obtained from the initial calibration measurement at pH 7 is selected since it is closest to the pH of the borehole water. This alternative is selected if the calibration constants obtained in the different buffers show a large variation in value (generally a difference larger than 20 mV between the highest and the lowest value). The standard deviation is calculated in the same way as in Case 1.
- Case 3: If the final calibration constants turn out to be very different (more than 20 mV) from the initial constants, a linear drift correction is needed. The reason for this is in most cases a drift in the reference electrode. The values and standard deviations are calculated for the initial and the final calibration constants separately and a linear correction is made between the selected initial and the selected final constant. The larger of the two standard deviation values is used in the estimation of the total measurement uncertainty.

The values in the measurement raw data file are converted to pH and Eh measurement sequences for each pH and redox electrode using the calibration constant selected, as stated above.

The next step is to choose a logging occasion within a stable part of the measurement period and select a representative result for each electrode. The average values are calculated for each electrode group in order to obtain one representative value each for redox potential and pH. Data from obviously erroneous electrodes are omitted. The corresponding total measurement uncertainties are estimated using the standard deviations of the calibration constants and the standard deviations of the Eh and the pH values obtained by the various sets of electrodes. Factors considered when evaluating the measurement uncertainties in pH and redox potential (Eh) values are:

- Difference in calibration constants for each electrode and calibration/buffer solution.
- Drift in calibration constants between the initial and the final calibration.
- Stability in voltage value during the final part of the on-line measurement.
- Number of electrodes showing reasonable agreement. Data from obviously erroneous electrodes are excluded from the calculation.

## 6.2 Water analysis data

The following routines for quality control and data management are generally applied for hydro-geochemical analysis of data, irrespective of sampling method or sampling object.

Some components are determined by more than one method and/or laboratory. Moreover, duplicate analyses by an independent laboratory are performed as a standard procedure on each fifth or tenth collected sample. All analytical results are stored in the Sicada database. The applied hierarchy path “Hydrochemistry/Hydrochemical investigation/Analyses/Water in the database” contains two types of tables, raw data tables and primary data tables (final data tables).

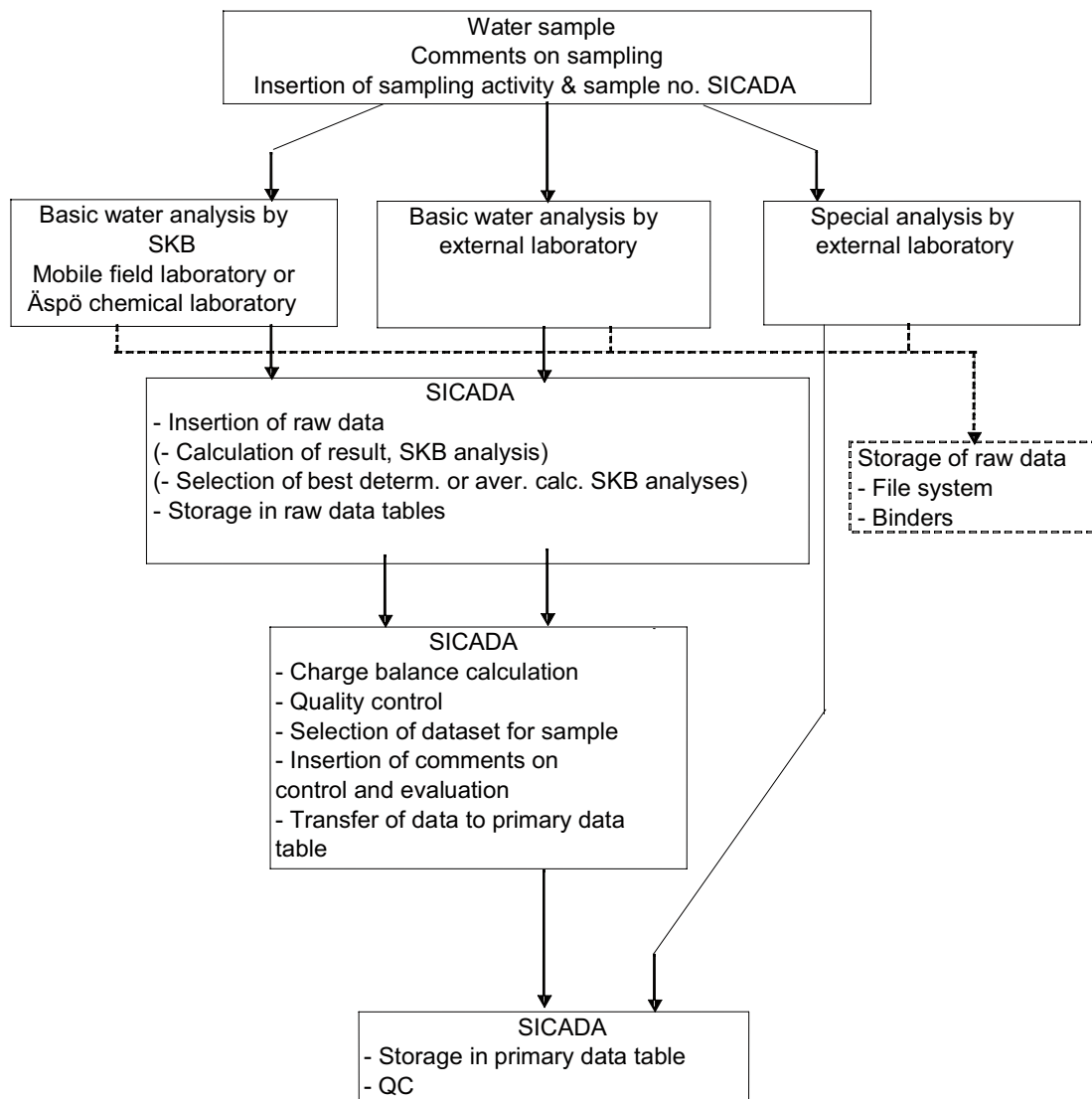
*Basic water analyses* data are inserted into the raw data tables for further evaluation. The evaluation results in a final reduced data set for each sample. These data sets are compiled in a primary data table named “water composition”. The evaluation is based on:

- Comparison of the results from different laboratories and/or methods. The analyses are repeated if a large disparity is noted (generally more than 10%).
- Calculation of charge balance errors according to the equation below. Relative errors within  $\pm 5\%$  are considered acceptable (in surface waters  $\pm 10\%$ ).

$$\text{Relative error (\%)} = 100 \times \frac{\sum \text{cations}(\text{equivalents}) - \sum \text{anions}(\text{equivalents})}{\sum \text{cations}(\text{equivalents}) + \sum \text{anions}(\text{equivalents})}$$

- General expert judgement of plausibility based on earlier results and experience.

All results from *special analyses of trace metals and isotopes* are inserted directly into primary data tables. In those cases where the analyses are repeated or performed by more than one laboratory, a “best choice” notation will indicate the results that are considered most reliable. An overview of the data management is given in Figure 6-1.



*Figure 6-1. Overview of data management for hydrogeochemical data.*

### 6.3 Data from special sampling methods

Special sampling methods in this investigation include collection of dissolved gases and enrichment of humic and fulvic acids. Separate sampling activities, methods and sample numbers are defined for data on dissolved gases and  $\delta^{13}\text{C}$  and pMC determined on organic constituents. All analytical data are subjected to quality control and stored in the Sicada database.

#### 6.3.1 Dissolved gases

The results of the gas analyses are stored in the primary data tables in Sicada. The gas results reported in Sicada correspond to values not corrected for air contamination. However, in this report also results that are corrected for air intrusion are presented.

#### 6.3.2 Enrichment of humic and fulvic acids

The pMC and  $\delta^{13}\text{C}$  values for enriched organic acids are stored in Sicada without processing or interpretation.

## 7 Results

### 7.1 Groundwater analyses

#### 7.1.1 Basic analyses

The basic analyses include the major constituents Na, K, Ca, Mg, S, Sr,  $\text{SO}_4^{2-}$ ,  $\text{Cl}^-$ , Si, and  $\text{HCO}_3^-$  as well as the minor constituents Fe, Li, Mn,  $\text{Br}^-$ ,  $\text{F}^-$ ,  $\text{I}^-$ ,  $\text{HS}^-$  and  $\text{NH}_4^+$ . Samples collected according to SKB chemistry class 5 also include P,  $\text{NO}_2^-$ ,  $\text{NO}_3^-$ , TOC and DOC. Furthermore, batch measurements of pH (lab-pH) and electrical conductivity (lab-EC) are included. Existing lab-pH and lab-EC values are compared with the corresponding on-line measurement values in Appendices 4, 5 and 6.

The charge balance errors provide an indication of the quality and uncertainty of the analyses of major constituents. The errors did not exceed the acceptable limit of  $\pm 5\%$  for any of the samples. The basic water analysis data and relative charge balance errors from the samples according to AP SFR 10-010 are compiled in Appendix 7, Table A7-1.

Diagrams showing the concentrations of chloride, calcium and sodium, during the period 1989 to 2010, for the borehole sections that are investigated yearly are displayed in Appendix 8. No major changes of the water chemistry in the boreholes that are included in the hydrochemistry monitoring program have been noted during 2010. A slow shift towards lower chloride concentrations can be observed when studying data for a longer period, even if the values from the last nine years seem to be more or less stable. The increasing admixture of Baltic seawater is most pronounced in the borehole KFR7A, but is also present in KFR01 and KFR10. In KFR08, the chloride concentration was only slightly higher than in the Baltic Sea at the start of the hydrochemistry monitoring program. Since then the chloride concentration has decreased and is at present comparable with the Baltic Sea concentration.

The concentrations of the major constituents remained relatively constant during the whole sampling period in the three borehole sections with supplementary redox investigations.

#### 7.1.2 Trace elements (rare earth metals and others)

The analyses of trace elements include Cr, Cu, Co, Ni, Mo, Pb, Zn, Sb, Al, U, Th, B, As, Sc, Cd, Hg, V, Rb, Y, Zr, In, Cs, Ba, La, Hf, Tl, Ce, Pr, Nd, Sm, Eu, Gd, Tb, Dy, Ho, Er, Tm, Yb as well as Lu and are compiled in Appendix 7, Table A7-2. Due to low natural concentrations and frequent use in various pieces of equipment, the risk of contamination is high for common metals like Cr, Cu, Co, Ni, Mo, Zn and Al. The uranium concentration was high in borehole KFR101, and rather high in all sections in borehole KFR02.

#### 7.1.3 Stable and radioactive isotopes

The isotope determinations include the stable isotopes  $\delta^2\text{H}$ ,  $\delta^{18}\text{O}$ ,  $^{10}\text{B}/^{11}\text{B}$ ,  $\delta^{34}\text{S}$ ,  $\delta^{13}\text{C}$ ,  $\delta^{37}\text{Cl}$ ,  $^{36}\text{Cl}/\text{total Cl}$  and  $^{87}\text{Sr}/^{86}\text{Sr}$  as well as the radioactive isotopes  $^3\text{H}$  (TU),  $^{238}\text{U}$ ,  $^{234}\text{U}$ ,  $^{230}\text{Th}$ ,  $^{226}\text{Ra}$  and  $^{222}\text{Rn}$ . In the three extensively investigated borehole sections, the carbon isotopes ( $\delta^{13}\text{C}$  and pmC) were determined in both inorganic carbon (bicarbonate) and in organic constituents. The results are presented in Table 7-1. The isotope units are explained in Appendix 1. Enrichment of organic carbon was necessary in order to collect enough amounts of organic material, mainly humic and fulvic acids. An extremely high pmC value (pmC=2310) was measured in inorganic carbon in a groundwater sample collected in the upper pump pit (drainage basin). The cause of this high  $^{14}\text{C}$  value is not known at present, and further investigations are planned with the aim to trace the  $^{14}\text{C}$  origin. Determinations restricted to  $\delta^{13}\text{C}$  and pmC in inorganic constituents were performed in KFR01, KFR02 and KFR55. All available isotope data are compiled in Appendix 7, Tables A7-3 and A7-4.

**Table 7-1. Inorganic and organic  $\delta^{13}\text{C}$  and pMC in water samples from KFR7A:1, KFR08:1 and KFR19:1.**

Borehole section (m)	Inorg. $\delta^{13}\text{C}$ (dev PDB)	Org. $\delta^{13}\text{C}$ (dev PDB)	Inorg. pMC	Org. pMC
KFR7A (48.0–74.7)	–6.9	–27.7	33.2	68.3
KFR08 (63.0–104.0)	–6.1	–27.8	48.0	84.8
KFR19 (95.6–110.0)	–5.8	–28.1	55.5	77.1

Diagrams showing the results from the analyses of  $^3\text{H}$  and  $\delta^{18}\text{O}$ , during the period 1989 to 2010, are displayed in Appendix 8.

#### 7.1.4 Dissolved gas

Sampling for gas was performed in KFR08:1 and KFR19:1. The analyses of dissolved gases included argon (Ar), helium (He), nitrogen ( $\text{N}_2$ ), carbon dioxide ( $\text{CO}_2$ ), methane ( $\text{CH}_4$ ), oxygen ( $\text{O}_2$ ), hydrogen ( $\text{H}_2$ ), ethane ( $\text{C}_2\text{H}_6$ ), ethene ( $\text{C}_2\text{H}_4$ ), ethyne ( $\text{C}_2\text{H}_2$ ), propane ( $\text{C}_3\text{H}_8$ ) and propene ( $\text{C}_3\text{H}_6$ ). The gas data are presented in Appendix 7, Table A7-5. Total gas content in the groundwater and the detected oxygen content are given as well as the respective values corrected for air intrusion. The concentration of helium was reported to be 8.2 ml/L in KFR08:1 and 6.2 ml/L in KFR19:1. However, these concentrations were considered unreasonably high and an analysis of pure neon gas showed an interfering peak at the same position as the helium peak in the GC chromatograms. Thus, these helium values are neither reported in Appendix 7 nor in Sicada.

## 7.2 On-line measurements

The data sequences of pH, Eh and temperature in KFR7A:1 and KFR08:1 are plotted versus time in Appendix 4 and 5, respectively. The data sequences of pH, Eh, electrical conductivity, oxygen and temperature from the Chemmac measurements in borehole section KFR19:1 are plotted versus time in Appendix 6. Measurement data from KFR19:1 during the period 2010-10-29 15:04 to 2010-11-02 15:50 and from KFR08:1 during 2010-12-07 10:02 to 2010-12-09 08:20 was lost because of a power failure.

The measured time series were evaluated in order to obtain representative values of pH, redox potential (Eh), electrical conductivity (EC) and dissolved oxygen for the borehole sections as described in Section 6.1. Data were selected from the last part of the measured time series sequences (where the electrodes show stable values), marked with an arrow in the diagrams. The evaluated results from the measurements in the investigated sections are given in Table 7-1.

The redox potentials of the electrodes in the surface Chemmac and measurement chamber reached stable and consistent values in all three measured borehole sections. At the end of the measurement period, the measured Eh values in KFR7A:1, KFR08:1 and KFR19:1 were –153 mV, –156 mV and –168 mV, respectively. The pH electrodes were consistent and stable in KFR7A:1 and KFR08:1. However, in KFR19:1 one of the electrodes showed obviously erroneous results and the values have been omitted.

**Table 7-2. Evaluated results from the on-line measurements in SFR.**

Borehole section [m]	Electrical conductivity* [mS/m]	pH**	Eh [mV]	Dissolved oxygen*** [mg/L]
KFR7A:1 (48.0–74.7)		7.4 ± 0.3	–153 ± 8	
KFR08:1 (63.0–104.0)		7.3 ± 0.3	–156 ± 11	
KFR19 (95.6–110.0)	910 ± 30	7.3 ± 0.3	–168 ± 13	0.02

\*The electrical conductivity is measured between 0–10,000 mS/m with a total uncertainty of 3%.

\*\* Evaluated result and measurement uncertainty calculated as described in section 5.1.

\*\*\* Measurement interval 0–15 mg/L, resolution and measurement uncertainty ± 0.01 mg/L.

### 7.2.1 Comparisons with previous redox (Eh) measurements

As mentioned earlier, previous interpretation of available data possibly indicated that Eh has changed (increased) since the 1980's due to the influence of the SFR depository. Some of the earlier data was considered quite uncertain, due to possible intrusion of oxygen in fittings as well as into tubings. The new measurements reported herein were carried out in order to verify if redox conditions have changed or not. In Table 7-3, all results from redox measurements performed in the SFR repository are presented. The new measurements were performed with extra cautions considering intrusion of oxygen, hence the number of fittings as well as the lengths of the tubings were minimized.

The negative redox values from 1986 to 1987 and from 2010 were obtained after long periods of water discharge and on-line measurements (3 to 7 weeks). The measurement periods during 2000 and 2009 were shorter and it cannot be entirely excluded that these measurements were performed on water affected by the oxic environment in the vicinity of the SFR tunnels. In KFR7A (Appendix 4, Figure A4-1), after one week a plateau around 50 mV for two of the electrodes can be seen from the redox measurements. This could reflect measurements on non-representative groundwater and the positive value from 2000 might also be such a value.

In summary, there is no clear evidence that any major changes of the general redox conditions in the SFR repository have occurred. However, in KFR7A a higher Eh value was measured in 2010 compared with the value from 1986 to 1987. The Eh measurements during 2010 may reflect the gradual removal of groundwater present in the borehole section. The redox conditions in the section may differ from that of the formation water in the water yielding fractures in the bedrock due to intrusion/diffusion of oxygen with time.

**Table 7-3. Results from redox measurements in SFR borehole sections.**

Borehole section (m)	Eh [mV] 1986–1987	Eh [mV] 2000	Eh [mV] 2009	Eh [mV] 2010
KFR01 (44.5–62.3)	-140	+110		
KFR7A (48.0–74.7)	-180	+30		-154
KFR10 (87.0–97.1)	(+60)*			
KFR10 (0.0–107.3)		+70		
KFR105 (120.0–137.0)			+40	
KFR105 (265.0–306.8)			+50	-190
KFR08 (63.0–104.0)				-156
KFR19 (95.6–110.0)				-168

\* Highly uncertain value.

## 8 Summary and discussion

### 8.1 Water chemistry in SFR

- The uranium concentrations in the analysed borehole sections were relatively low, except in KFR101 (279 to 342 m borehole length); 35 µg/L.
- All of the samples show low sulphide concentrations.

The following observations can be made from data in Appendix 7 and from the diagrams in Appendix 8:

- The groundwater in KFR01 has a mixed transition character with an initial chloride concentration of c 4,000 mg/L and shows a distinct but slow change towards recent sea water outside Forsmark. The sampled borehole section represents the Singö zone.
- The groundwater in borehole KFR7A clearly showed the highest chloride concentration at the start of the monitoring program in 1989, c 5,200 mg/L and also shows the largest change of the water chemistry until today. The change consists of a displacement from a clear marine (Littorina) character towards an increasing admixture of modern brackish seawater. The sampled borehole section represents the subvertical zone 8 and may also be connected to zone H2, which may explain the change in the water composition.
- The groundwater in borehole KFR08 is the one that most resembles the recent seawater composition regarding e.g. chloride concentrations. The bottom of the borehole reaches the vertical zone 8, which may explain the contact with seawater. The tritium values from the last five years are slightly lower than the values previously measured in the borehole.
- Also the groundwater in KFR10 has Littorina character (initially 4,500 mg/L chloride) and also in this case a shift towards the recent seawater outside Forsmark may be discerned, even if the trend is vague. The sampled borehole section represents zone 3.

### 8.2 Supplementary hydrochemical (redox; Eh) investigations

The hydrochemical investigations in KFR7A:1, KFR08:1 and KFR19:1 in October to December 2010 included collection of three samples from each of the borehole sections. Some observations regarding the performance and the results are listed below:

- The measured Eh values were stable as well as consistent in all three investigated borehole sections.
- The on-line measured oxygen concentration in KFR19:1 seems unreliable during the second part of the measurement period.
- The water compositions were stable within each time series.
- The pressure responses indicate that there is short-circuiting between sections KFR19:1 and KFR19:2. This may affect the composition of samples from these sections.
- All three investigated borehole sections show clearly marine oxygen-18 signatures with relatively high values.
- The redox data obtained seem to show that no major changes of the redox conditions in the SFR repository boreholes have occurred since 1986/87. The positive Eh values that have been obtained from time to time are most probably due to artefacts i.e. too short measurement periods to exchange completely the groundwater staying in the borehole section. However, possible intrusion of oxygenated Baltic Sea water through major deformation zones cannot be completely ruled out.
- The sample taken in the upper pump pit (drainage basin) showed a very high content of <sup>14</sup>C (pMC). The reason for this is unknown at present, but further investigations with the aim to trace the <sup>14</sup>C source are planned.



## References

SKB's (Svensk Kärnbränslehantering AB) publications can be found at [www.skb.se/publications](http://www.skb.se/publications).

**Jönsson S, 2011.** Personal communication.

**Nilsson A-C, Tullborg E-L, Smellie J, 2010.** Preliminary hydrogeochemical site description SFR (version 0.2). SKB R-10-38, Svensk Kärnbränslehantering AB.

**SKB, 2008.** Geovetenskapligt undersökningsprogram för utbyggnad av SFR. SKB R-08-67, Svensk Kärnbränslehantering AB.



## Sampling and analytical methods

**Table A1-1. Sample handling routines and analytical methods.**

Component group	Component/ element	Sample container (material)	Volume (mL)	Filtering	Preparation/ Conservation*	Analysis method	Analysis within – or delivery time to lab.
Anions 1	HCO <sub>3</sub> pH(lab) cond (lab)	Plastic	250	Yes (at the laboratory)	No	Titration Pot. meas, Cond. meas	The same day – maximum 24 hours
Anions 2	Cl, SO <sub>4</sub> , Br, F, I <sup>-</sup>	Plastic	100	Yes (at the laboratory)	No	Titration (Cl) IC (Cl, SO <sub>4</sub> , Br, F) ISE (F <sup>-</sup> )	Not critical (month)
	Br, I	Plastic	100	Yes (at the laboratory)	No	ICP MS	Not critical (month)
Cations, Si and S according to SKB class 3	Na, K, Ca, Mg, S(tot), Si(tot), Li, Sr	Plastic (at low conc. acid washed bottles)	100	Yes (at the laboratory)	Yes (not in the field, 1 mL HNO <sub>3</sub> )	ICP-AES ICP-MS	Not critical (month)
Cations, Si and S according to SKB class 4 and 5	Na, K, Ca, Mg, S(tot), Si(tot), Fe, Mn, Li, Sr	Plastic (Acid washed)	100	Yes (immediately in the field)	Yes (1mL HNO <sub>3</sub> )	ICP-AES ICP-MS	Not critical (month)
Fe(II), Fe(tot)	Fe(II), Fe(tot)	Plastic (Acid washed)	500	Yes	Yes (5 mL HCl)	Spectrophotometry Ferrozine method	As soon as possible the same day
Hydrogen sulphide	HS-	Glass (Winkler)	About 120-2	No	Ev. 1 mL 1 M NaOH+ 1 mL 1M ZnAc	Spectrophotometry	Immediately or if conserved, a few days
Environmental metals	Al, As, Ba, B, Cd, Co, Cr, Cu, Hg, Mo, Ni, P, Pb, V, Zn	Plastic (Acid washed)	100	Yes	Yes (1 mL HNO <sub>3</sub> )	ICP-AES ICP-MS	Not critical (month)
Lantanoids, U, Th and so on	Sc, Rb, Y, Zr, I, Sb, Cs, La, Hf, Tl, Ce, Pr, Nd, Sm, Eu, Gd, Tb, Dy, Ho, Er, Tm, Yb, Lu, U, Th	Plastic (Acid washed)	100	Yes	Yes (1 mL HNO <sub>3</sub> )	ICP-AES ICP-MS	Not critical (month)
Dissolved organic Carbon, dissolved inorganic Carbon	DOC, DIC	Plastic	250 25	Yes	Frozen, transported in isolated bag	UV oxidation, IR Carbon analysator Shimadzu TOC5000	Short transportation time
Total organic Carbon	TOC	Plastic	250 25	No	Frozen, transported in isolated bag	UV oxidation, IR Carbon analysator Shimadzu TOC5000	Short transportation time

Component group	Component/ element	Sample container (material)	Volume (mL)	Filtering	Preparation/ Conservation*	Analysis method	Analysis within – or delivery time to lab.
Environmental isotopes	<sup>2</sup> H, <sup>18</sup> O	Plastic	100	No	-	MS	Not critical (month)
Tritium	<sup>3</sup> H (enhanced.)	Plastic (dry bottle)	500	No	-	LSC	Not critical (month)
Chlorine-36	<sup>36</sup> Cl	Plastic	1000	No	-	(A)MS	No limit
Chlorine-37	<sup>37</sup> Cl	Plastic	100	No	-	MS	No limit
Carbon isotopes	<sup>13</sup> C, <sup>14</sup> C (pmC)	Glass (brown)	100-2	No	-	(A)MS	A few days
Sulphur isotopes	<sup>34</sup> S	Plastic	500–1000	Yes	-	Combustion, MS	No limit
Strontium-isotopes	<sup>87</sup> Sr/ <sup>86</sup> Sr	Plastic	100	Yes	-	TIMS	Days or Week
Uranium and Thorium isotopes	<sup>234</sup> U, <sup>235</sup> U, <sup>238</sup> U, <sup>232</sup> Th, <sup>230</sup> Th,	Plastic	50	Nej	-	Alfa spectroscopy	No limit
Boron isotopes	<sup>10</sup> B	Plastic	100	Yes	Yes (1 mL HNO <sub>3</sub> )	ICP – MS	No limit
Radon and Radium isotopes	<sup>222</sup> Rn, <sup>226</sup> Ra	Plastic	500	No	No	LSS	Immediate transport
Dissolved gas (content and composition)	Ar, N <sub>2</sub> , CO <sub>2</sub> , O <sub>2</sub> , CH <sub>4</sub> , H <sub>2</sub> , CO, C <sub>2</sub> H <sub>2</sub> , C <sub>2</sub> H <sub>4</sub> , C <sub>2</sub> H <sub>6</sub> , C <sub>3</sub> H <sub>8</sub>	Cylinder of stainless steel	200	No	No	GC	Immediate transport
Colloids	Filter series and fractionation (see below)	Polycarbonate filter	0.45, 0.2 and 0.05 μm	-	N <sub>2</sub> atmosphere	ICP-AES ICP-MS	Immediate transport
Humic and fulvic acids	Fractionation	Fractions are collected in plastic bottles	250	-	N <sub>2</sub> atmosphere	UV oxidation, IR (DOC)	Immediate transport
Archive samples with acid	-	Plast (washed in acid)	100-2 **	Yes	Yes (1 mL HNO <sub>3</sub> )	-	Storage in freeze container
Archive samples without acid	-	Plastic	250-2 **	Yes	No	-	Storage in freeze container
Carbon isotopes in humic and fulvic acids	<sup>13</sup> C, <sup>14</sup> C (pmC)	DEAE cellulose (anion exchanger)	-	-	-	(A)MS	A few days
Nutrient salt + silicate	NO <sub>2</sub> , NO <sub>3</sub> , NO <sub>2</sub> +NO <sub>3</sub> , NH <sub>4</sub> , PO <sub>4</sub> , SiO <sub>4</sub>	Sample tubes, plastic	25-2	Yes (in the field)	No, frozen immediately***	Spectrophotometry	Short transportation time
Total concentrations of Nitrogen and Phosphorous	N-tot, P-tot	Plastic	100	No	No, frozen immediately***	Spectrophotometry	Short transportation time
Particulate Carbon, Nitrogen and Phosphorous	POC, PON, POP	Plastic	1000	Yes (within 4 h) prepared filters. Blank filters	Filtering, the filters are frozen immediately 2 filters/sample	Elementar-analysator (N, C) own method 990121 (P)	Short transportation time

Component group	Component/ element	Sample container (material)	Volume (mL)	Filtering	Preparation/ Conservation*	Analysis method	Analysis within – or delivery time to lab.
Chlorophyll	Chlorophyll a, c and pheopigment	Plastic	1000-2000	Yes (within 4 h)	Filtering, the filters are frozen immediately	Spectrophotometry Fluorometry	Short transportation time
Oxygen	Dissolved O <sub>2</sub>	Winkler, glass	2-ca 120	No	Mn (II) reagent Iodide reagent	Spectrophotometry SIS SS-EN 25813	Within 3 days
Archive samples for supplementary radio nuclides		Plastic	5000	No	50 mL HNO <sub>3</sub>	-	Storage in freeze container

\* Suprapur acid is used for conservation of samples.

\*\* Minimum number. The number of archive samples can vary depending on the number of similar samples collected at the same occasion.

\*\*\* The sample is transported in frozen condition to the laboratory. It is possible that the silicate concentration can change due to polymerisation for this reason.

#### Abbreviations and definitions:

IC	Ion chromatograph.
ISE	Ion selective electrode.
ICP-AES	Inductively Coupled Plasma Atomic Emission Spectrometry.
ICP-MS	Inductively Coupled Plasma Mass Spectrometry.
INAA	Instrumental Neutron Activation Analysis.
MS	Mass Spectrometry
TIMS	Thermal Ionization Mass Spectrometer.
LSC	Liquid Scintillation Counting.
(A)MS	(Accelerator) Mass Spectrometry.
GC	Gas Chromatography.
LSS	Liquid Scintillation Spectroscopy.

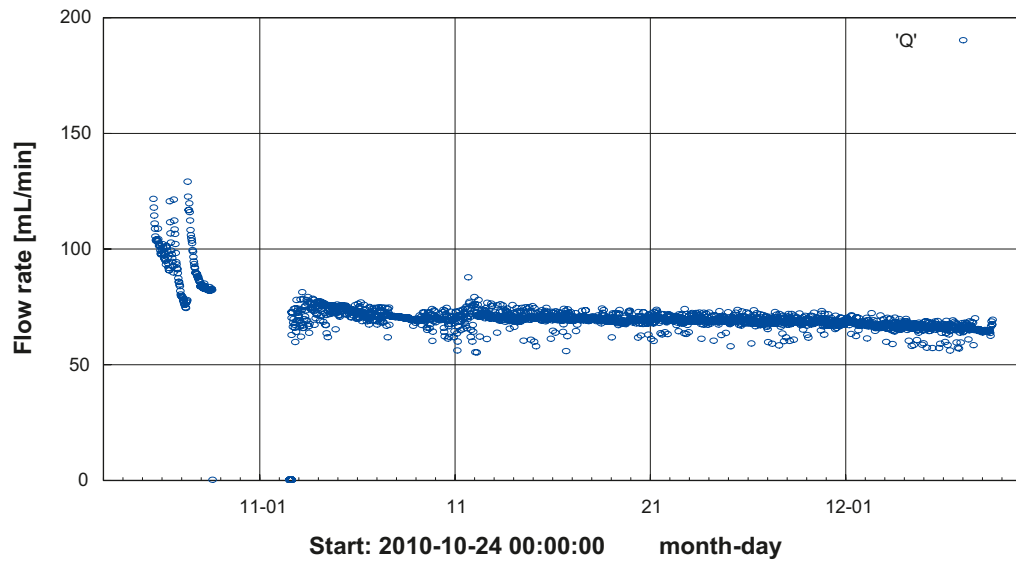
**Table A1-2. Reporting limits and measurement uncertainties, updated 2008.**

Component	Method <sup>1</sup>	Reporting limits (RL), detection limits (DL) or range <sup>2</sup>	Unit	Measurement uncertainty <sup>3</sup>
pH	Potentiometric	3–10	pH unit	±0.1
EC	Electrical Conductivity meas.	1–150 150–10,000	mS/m	5% 3%
HCO <sub>3</sub>	Alkalinity titration	1	mg/L	4%
Cl <sup>-</sup>	Mohr- titration	≥ 70	mg/L	5%
Cl <sup>-</sup>	IC	0.5–70		8%
SO <sub>4</sub>	IC	0.5	mg/L	12%
Br <sup>-</sup>	IC	DL 0.2, RL 0.5	mg/L	15%
Br	ICP SFMS	0.001, 0.004, 0.010 <sup>4</sup>	mg/L	25% <sup>5</sup>
F <sup>-</sup>	IC	DL 0.2, RL 0.5	mg/L	13%
F <sup>-</sup>	Potentiometric	DL 0.1, RL 0.2		12%
I <sup>-</sup>	ICP SFMS	0.001, 0.004, 0.010 <sup>4</sup>	mg/L	25% <sup>5</sup>
Na	ICP AES	0.1	mg/L	13%
K	ICP AES	0.4	mg/L	12%
Ca	ICP AES	0.1	mg/L	12%
Mg	ICP AES	0.09	mg/L	12%
S(tot)	ICP AES	0.16	mg/L	12%
Si(tot)	ICP AES	0.03	mg/L	14%
Sr	ICP AES	0.002	mg/L	12%
Li	ICP AES	0.004	mg/L	12.2%
Fe	ICP AES	0.02	mg/L	13.3% <sup>6</sup>
Fe	ICP SFMS	0.0004, 0.002, 0.004 <sup>4</sup>	mg/L	20% <sup>6</sup>
Mn	ICP AES	0.003	mg/L	12.1% <sup>5</sup>
Mn	ICP SFMS	0.00003, 0.00004, 0.0001 <sup>4</sup>	mg/L	53% <sup>6</sup>
Fe(II), Fe(tot)	Spectrophotometry	DL 0.006, RL 0.02	mg/L	0.005 (0.02-0.05 mg/L) 9% (0.05-1 mg/L) 7% (1-3 mg/L)
HS <sup>-</sup>	Spectrophotometry, SKB	SKB DL 0.006, RL 0.02	mg/L	25%
HS <sup>-</sup>	Spectrophotometry, external laboratory	0.01	mg/L	0.02 (0.01-0.2 mg/L) 12% (>0.2 mg/L)
NO <sub>2</sub> as N	Spectrophotometry	0.1	µg/L	2%
Component	Method <sup>1</sup>	Reporting limits (RL), detection limits (DL) or range <sup>2</sup>	Unit	Measurement uncertainty <sup>3</sup>
NO <sub>3</sub> as N	Spectrophotometry	0.2	µg/L	5%
NO <sub>2</sub> +NO <sub>3</sub> as N	Spectrophotometry	0.2	µg/L	0.2 (0.2-20 µg/L) 2% (> 20 µg/L)
NH <sub>4</sub> as N	Spectrophotometry, SKB	11	µg/L	30% (11-20 µg/L) 25% (20-50 µg/L) 12% (50-1200 µg/L)
NH <sub>4</sub> as N	Spectrophotometry external laboratory	0.8	µg/L	0.8 (0.8-20 µg/L) 5% (> 20 µg/L)
PO <sub>4</sub> as P	Spectrophotometry	0.7	µg/L	0.7 (0.7-20 µg/L) 3% (> 20 µg/L)
SiO <sub>4</sub>	Spectrophotometry	1	µg/L	2.5% (>100 µg/L)
O <sub>2</sub>	Iodometric titration	0.2–20	mg/L	5%
Chlorophyll a, c pheopigment <sup>7</sup>	/1/	0.5	µg/L	5%
PON <sup>7</sup>	/1/	0.5	µg/L	5%
POP <sup>7</sup>	/1/	0.1	µg/L	5%
POC <sup>7</sup>	/1/	1	µg/L	4%
Tot-N <sup>7</sup>	/1/	10	µg/L	4%
Tot-P <sup>7</sup>	/1/	0.5	µg/L	6%
Al,	ICP SFMS	0.2, 0.3, 0.7 <sup>4</sup>	µg/L	17.6% <sup>6</sup>
Zn	ICP SFMS	0.2, 0.8, 2 <sup>4</sup>	µg/L	15.5, 17.7, 25.5% <sup>6</sup>
Ba, Cr, Mo,	ICP SFMS	0.01, 0.04, 0.1 <sup>4</sup>	µg/L	Ba 15% <sup>4</sup> , Cr 22% <sup>5</sup> Mo 39% <sup>5</sup>
Pb	ICP SFMS	0.01, 0.1, 0.3 <sup>4</sup>	µg/L	15% <sup>6</sup>
Cd	ICP SFMS	0.002, 0.02, 0.5 <sup>4</sup>	µg/L	15.5% <sup>6</sup>
Hg	ICP AFS	0.002	µg/L	10.7% <sup>6</sup>
Co	ICP SFMS	0.005, 0.02, 0.05 <sup>4</sup>	µg/L	25.9% <sup>6</sup>
V	ICP SFMS	0.005, 0.03, 0.05 <sup>4</sup>	µg/L	18.1% <sup>6</sup>

Component	Method <sup>1</sup>	Reporting limits (RL), detection limits (DL) or range <sup>2</sup>	Unit	Measurement uncertainty <sup>3</sup>
Cu	ICP SFMS	0.1, 0.2, 0.5 <sup>4</sup>	µg/L	14.4% <sup>6</sup>
Ni	ICP SFMS	0.05, 0.2, 0.5 <sup>4</sup>	µg/L	15.8% <sup>6</sup>
P	ICP SFMS	1, 5, 40 <sup>4</sup>	µg/L	16.3% <sup>6</sup>
As	ICP SFMS	0.01 (520 mS/m)	µg/L	59.2% <sup>6</sup>
La, Ce, Pr, Nd, Sm, Eu, Gd, Tb, Dy, Ho, Er, Tm, Yb, Lu	ICP SFMS	0.005, 0.02, 0.05 <sup>4</sup>	µg/L	20%, 20%, 25% <sup>6</sup>
Sc, In, Th	ICP SFMS	0.05, 0.2, 0.5 <sup>4</sup>	µg/L	25% <sup>6</sup>
Rb, Zr, Sb, Cs	ICP SFMS	0.025, 0.1, 0.25 <sup>4</sup>	µg/L	15%, 20%, 20% <sup>5</sup> 25% <sup>6</sup>
Tl	ICP SFMS	0.025, 0.1, 0.25 <sup>4</sup>	µg/L	14.3% <sup>5 and 6</sup>
Y, Hf	ICP SFMS	0.005, 0.02, 0.05 <sup>4</sup>	µg/L	15%, 20%, 20% <sup>5</sup> 25% <sup>6</sup>
U	ICP SFMS	0.001, 0.005, 0.01 <sup>4</sup>	µg/L	13.5%, 14.3%, 15.9% <sup>5</sup> 19.1%, 17.9%, 20.9% <sup>6</sup>
DOC	UV oxidation, IR Carbon analysator	0.5	mg/L	8%
TOC	UV oxidation, IR Carbon analysator	0.5	mg/L	10%
δ <sup>2</sup> H	MS	2	‰ SMOW <sup>8</sup>	0.9 (one standard deviation)
δ <sup>18</sup> O	MS	0.1	‰ SMOW <sup>8</sup>	0.1 (one standard dev.)
<sup>3</sup> H	LSC	0.8	TU <sup>9</sup>	0.8
δ <sup>36</sup> Cl	A (MS)	–	No unit (ratio) <sup>14</sup>	17%
δ <sup>37</sup> Cl	A (MS)	0.2	‰ SMOC <sup>10</sup>	0.2 <sup>17</sup>
δ <sup>13</sup> C	A (MS)	–	‰ PDB <sup>11</sup>	0.3 <sup>17</sup>
<sup>14</sup> C pmc	A (MS)	–	pmC <sup>12</sup>	0.4 <sup>17</sup>
δ <sup>34</sup> S	MS	0.2	‰ CDT <sup>13</sup>	0.4 (one standard dev.)
<sup>87</sup> Sr/ <sup>86</sup> Sr	TIMS	–	No unit (ratio) <sup>14</sup>	0.00002
<sup>10</sup> B/ <sup>11</sup> B	ICP SFMS	–	No unit (ratio) <sup>14</sup>	–
<sup>234</sup> U, <sup>235</sup> U, <sup>238</sup> U, <sup>232</sup> Th, <sup>230</sup> Th	Alfa spectr.	0.0001	Bq/L <sup>15</sup>	≤5% (Counting statistics uncertainty)
<sup>222</sup> Rn, <sup>226</sup> Ra	LSS	0.015	Bq/L	≤5% (Count. stat. uncert.)

- Many elements may be determined by more than one ICP technique depending on concentration range. The most relevant technique and measurement uncertainty for the concentrations normally encountered in groundwater are presented. In cases where two techniques were frequently used, both are displayed.
- Reporting limits (RL), generally 10×standard deviation, if nothing else is stated. Measured values below RL or DL are stored as negative values in SICADA (i.e. – RL value and – DL value).
- Measurement uncertainty reported by the laboratory, generally as ± percent of measured value in question at 95% confidence interval.
- Reporting limits at electrical cond. 520 mS/m, 1440 mS/m and 3810 mS/m respectively.
- Measurement uncertainty at concentrations 100×RL.
- Measurement uncertainty at concentrations 10×RL.
- Determined only in surface waters. PON, POP and POC refers to Particulate Organic Nitrogen, Phosphorous and Carbon, respectively.
- Per mille deviation<sup>16</sup> from SMOW (Standard Mean Oceanic Water).
- TU=Tritium Units, where one TU corresponds to a tritium/hydrogen ratio of 10<sup>-18</sup> (1 Bq/L Tritium = 8.45 TU).
- Per mille deviation<sup>16</sup> from SMOC (Standard Mean Oceanic Chloride).
- Per mille deviation<sup>16</sup> from PDB (the standard PeeDee Belemnite).
- The following relation is valid between pmC (percent modern carbon) and Carbon-14 age: pmC = 100 · e<sup>(1950-y-1.031)(8274)</sup> where y = the year of the C-14 measurement and t = C-14 age.
- Per mille deviation<sup>16</sup> from CDT (the standard Canyon Diablo Troilite).
- Isotope ratio without unit.
- The following expressions are applicable to convert activity to concentration, for uranium-238 and thorium-232: 1 ppm U = 12.4 Bq/kg<sup>238</sup>U, 1 ppm Th = 3.93 Bq/kg<sup>232</sup>Th.
- Isotopes are often reported as per mill deviation from a standard. The deviation is calculated as: δ‰ = 1000×(K<sub>sample</sub> - K<sub>standard</sub>)/K<sub>standard</sub>, where K = the isotope ratio and ‰ = <sup>2</sup>H, <sup>18</sup>O, <sup>37</sup>Cl, <sup>13</sup>C or <sup>34</sup>S etc.
- SKB estimation from duplicate analyses by the contracted laboratory.

**Flow rate during on-line measurements in KFR19,  
section 95.6–110.0 m**



*Figure A2-1. Pumping flow rate (Q), section 95.6-110.0 m.*

Pressure registrations during measurements and sampling, HMS system

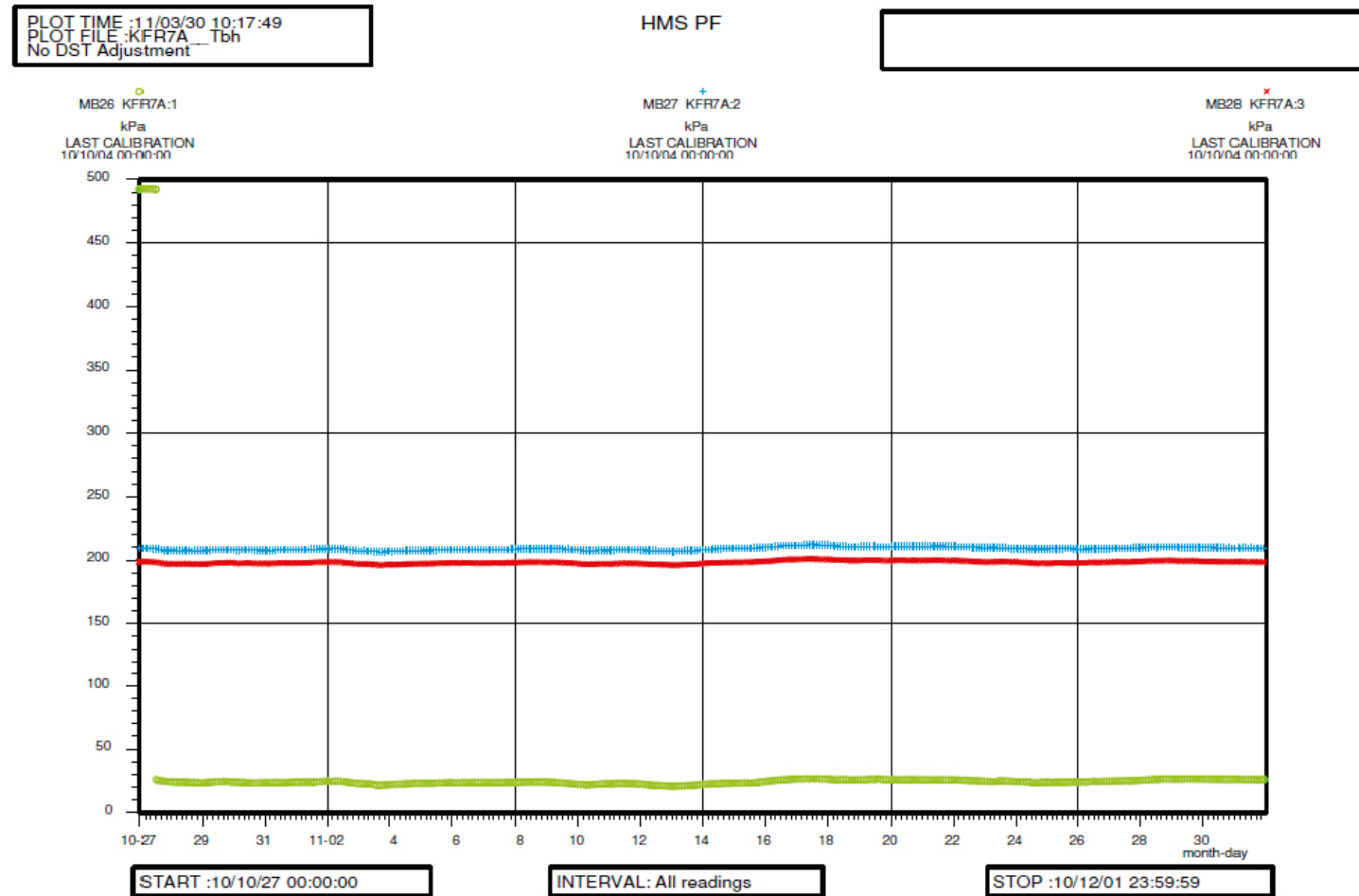
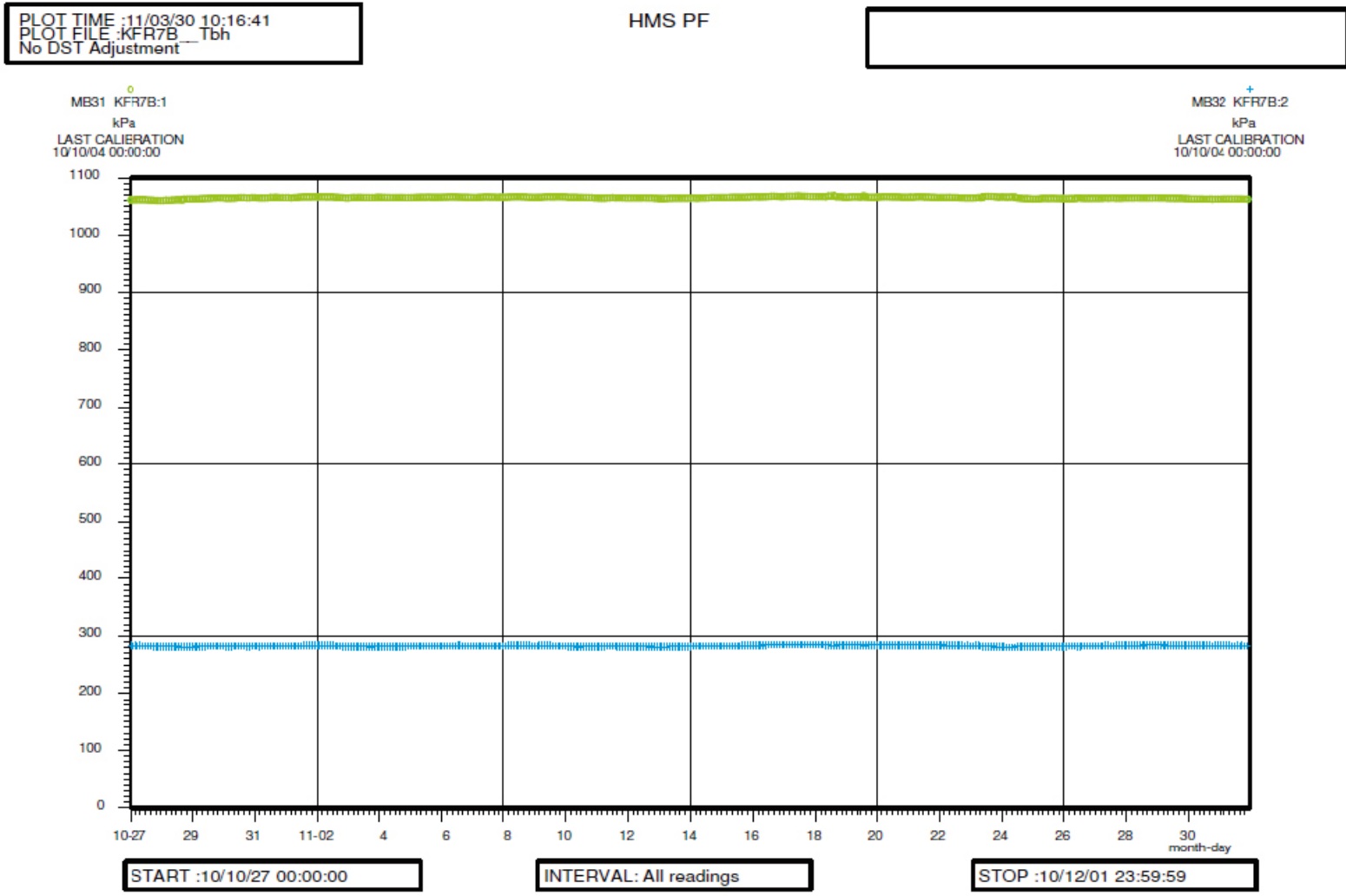
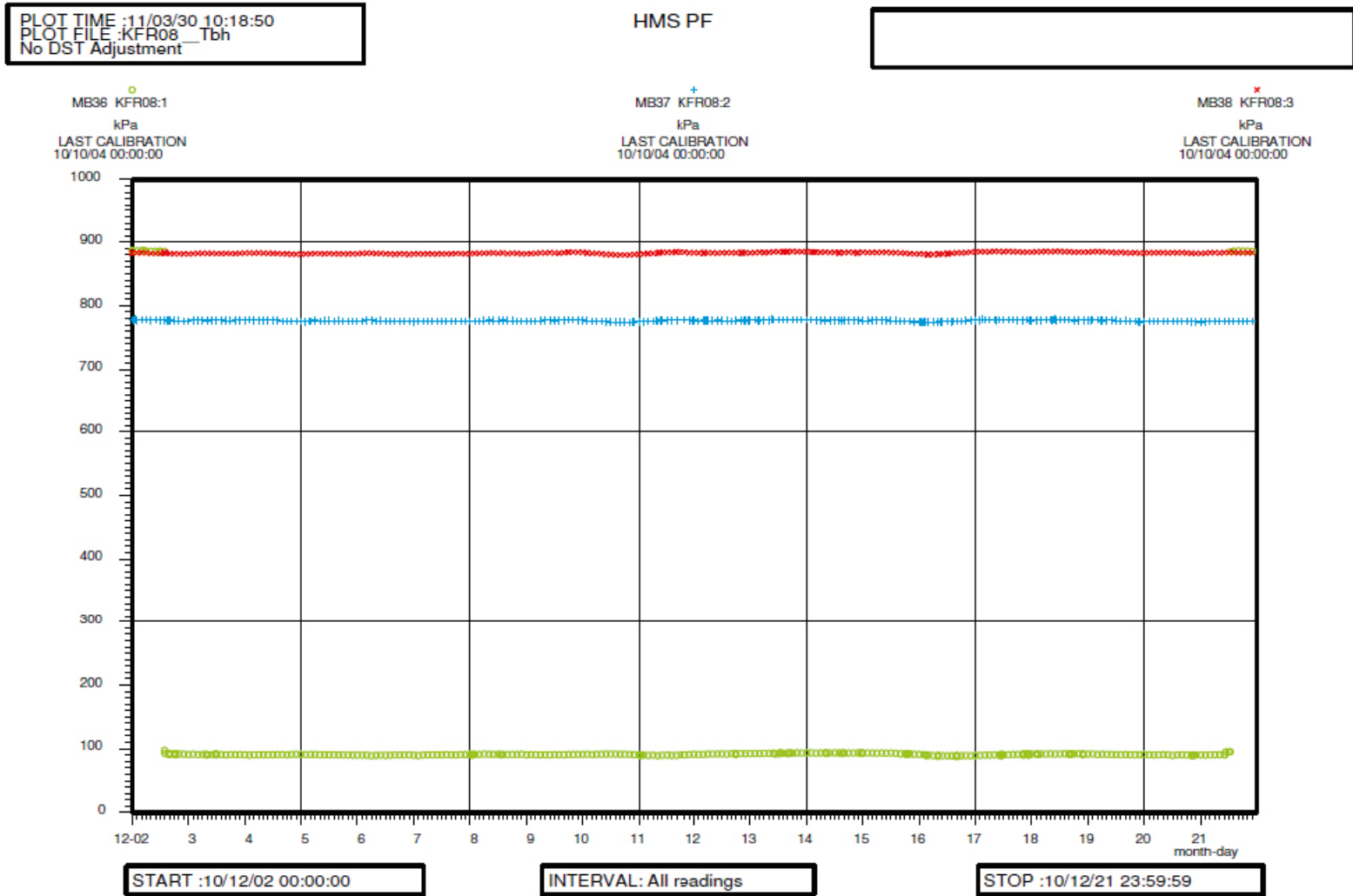


Figure A3-1. Pressure registration in KFR7A during the hydrochemical investigation (October to November 2010). The figure shows the pressure registration in all three sections in KFR7A, where section 1 was cut for the investigation. No pressure responses can be noticed.

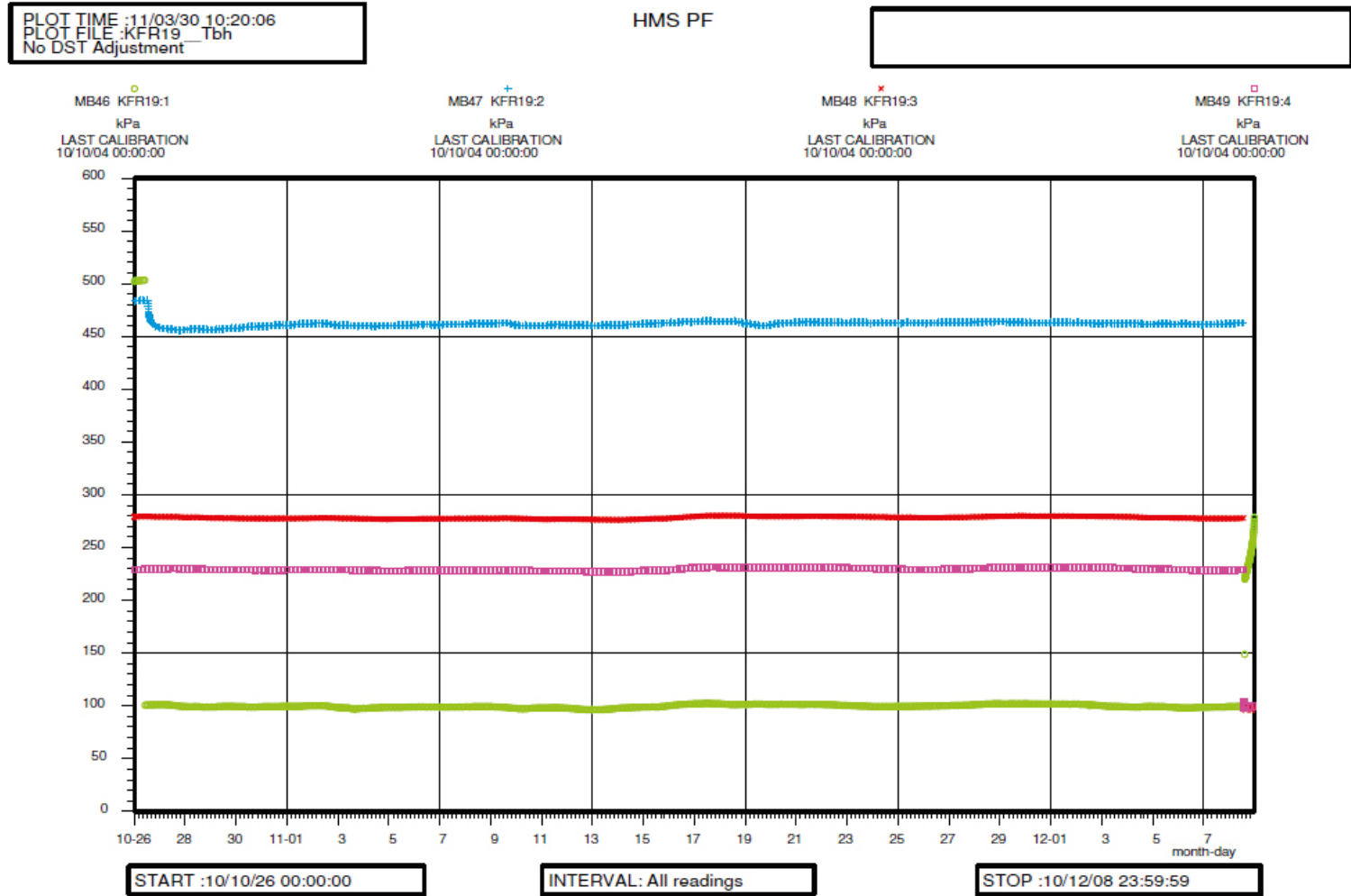


**Figure A3-2.** Pressure registration in KFR7B during the hydrochemical investigation in KFR7A (October to November 2010). The figure shows the pressure registration in the two sections in KFR7B. No pressure responses can be noticed.



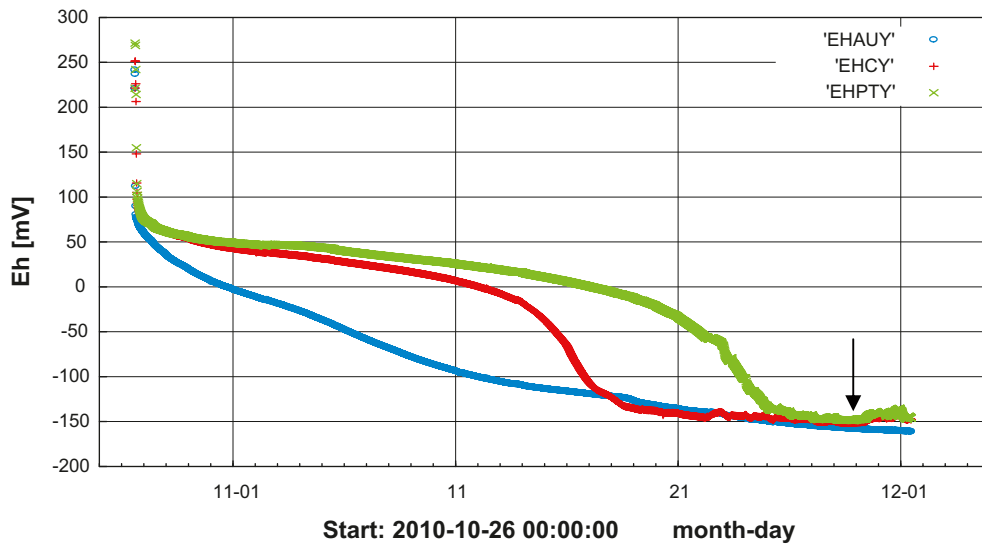


*Figure A3-3. Pressure registration in KFR08 during the hydrochemical investigation in KFR08 (December 2010). The figure shows the pressure registration in all three sections in KFR08, where section 1 was cut for the investigation. No pressure responses can be noticed.*

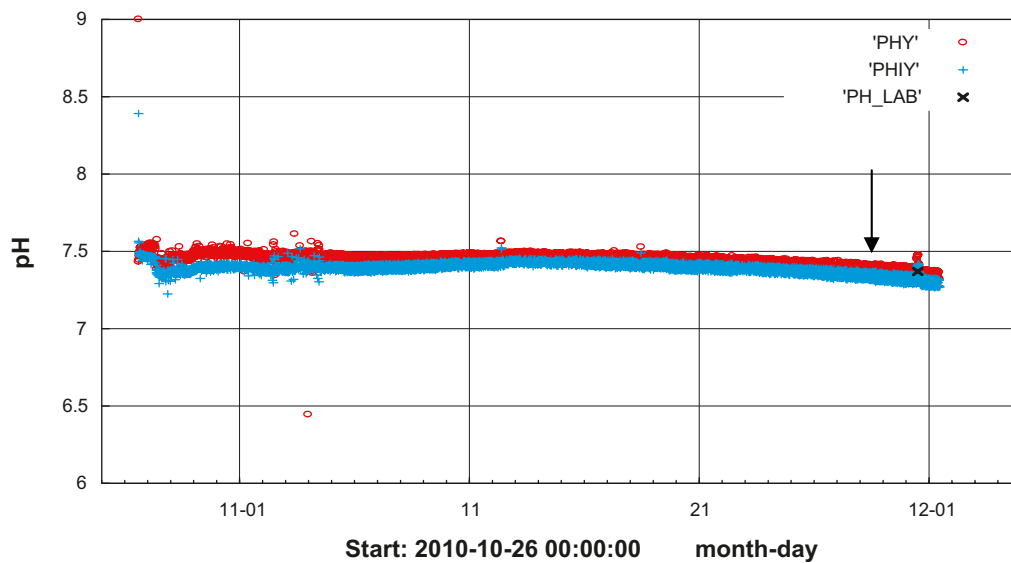


**Figure A3-4.** Pressure registration in KFR19 during the hydrochemical investigation in KFR19 (October to December 2010). The figure shows the pressure registration in all four sections in KFR19, where section 1 was cut for the investigation. Some pressure response can be noticed in section KFR19:2 (77.6 m to 94.6 m borehole length).

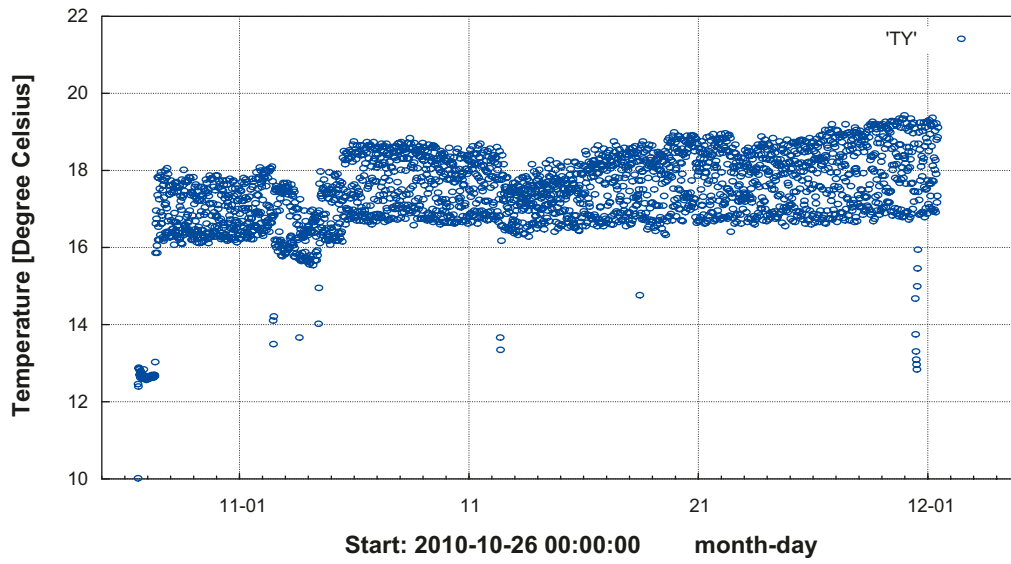
On-line measurements in KFR7A, section 48.0–74.7 m



**Figure A4-1.** Redox potential measurements (Eh) by gold, glassy carbon and platinum electrodes (EHAUY, EHCY and EHPTY). The arrow shows the selected representative Eh value for the borehole section.

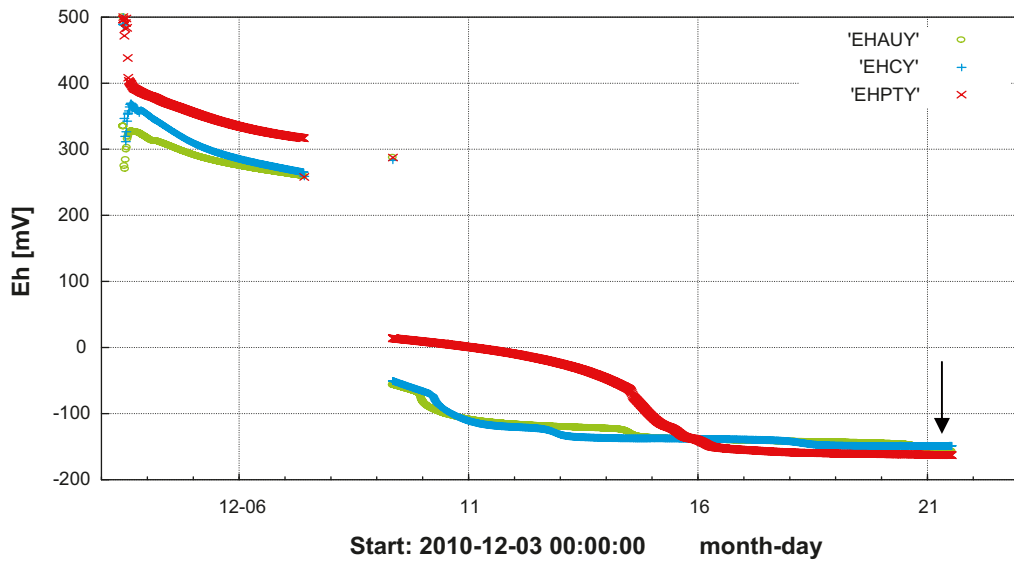


**Figure A4-2.** Measurements of pH by two glass electrodes (PHY and PHIY). The laboratory pH in each collected sample (PHL) is given for comparison. The arrow shows the selected representative pH value for the borehole section.

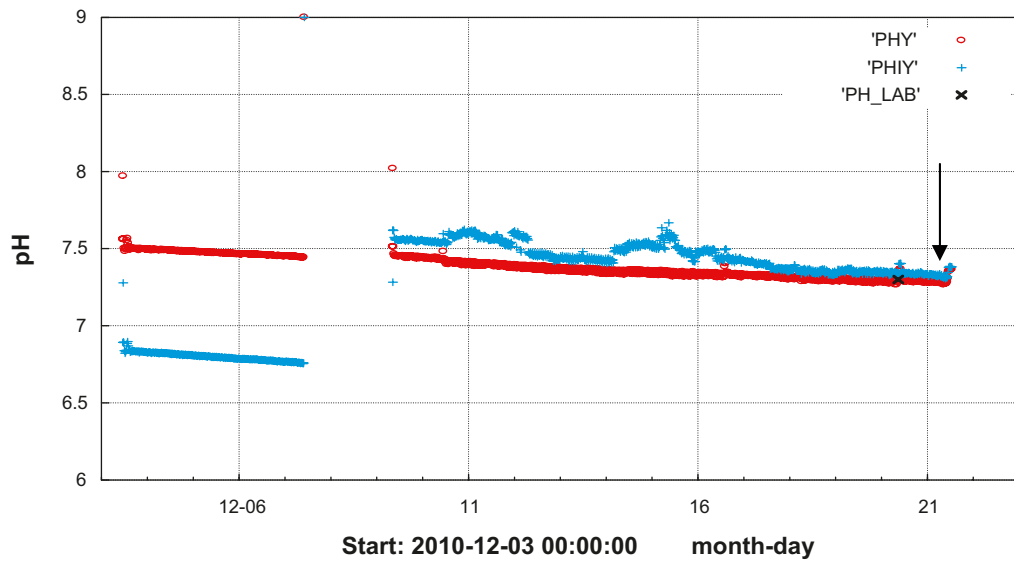


*Figure A4-3. Water temperature in the measurement cell (TY).*

On-line measurements in KFR08, section 63.0–104.0 m



**Figure A5-1.** Redox potential measurements (Eh) by gold, glassy carbon and platinum electrodes (EHAUY, EHCY and EHPTY). The arrow shows the selected representative Eh value for the borehole section.



**Figure A5-2.** Measurements of pH by two glass electrodes (PHY and PHIY). The laboratory pH in each collected sample (PHL) is given for comparison. The arrow shows the selected representative pH value for the borehole section.

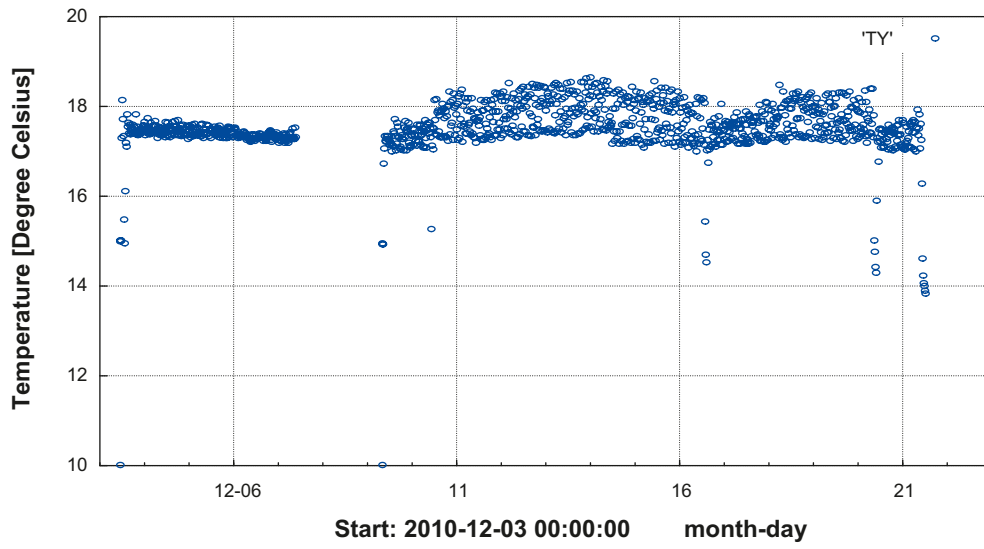
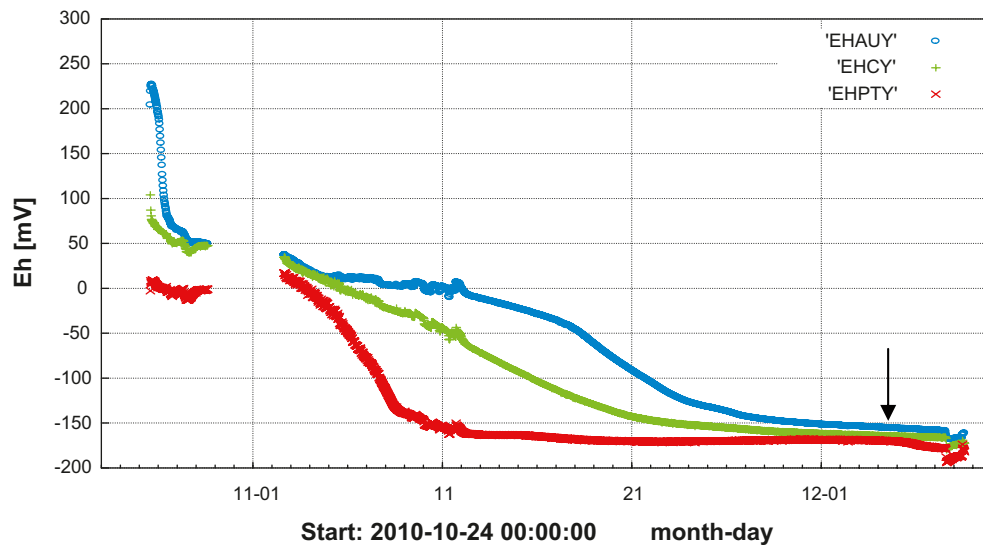
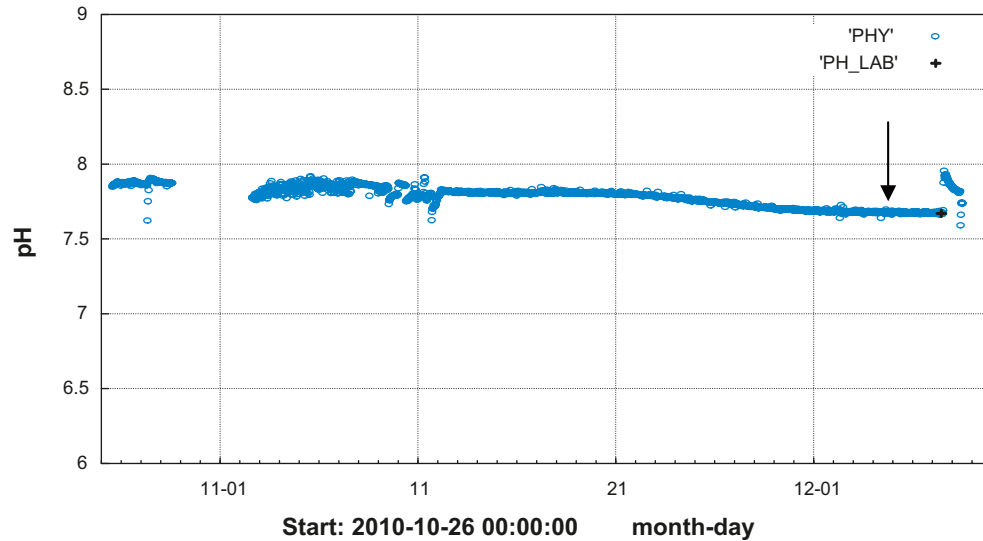


Figure A5-3. Water temperature in the measurement cell (TY).

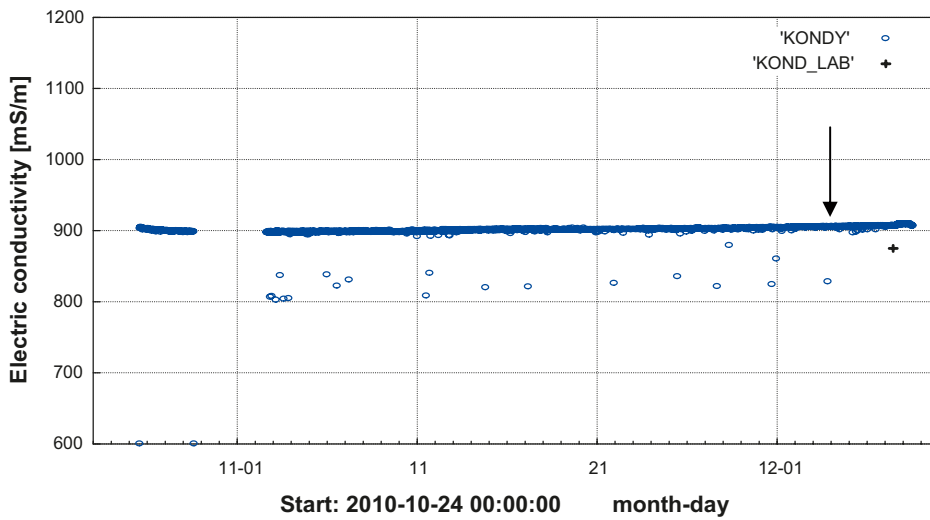
## Chemmac measurements in KFR19, section 95.0–110.0 m



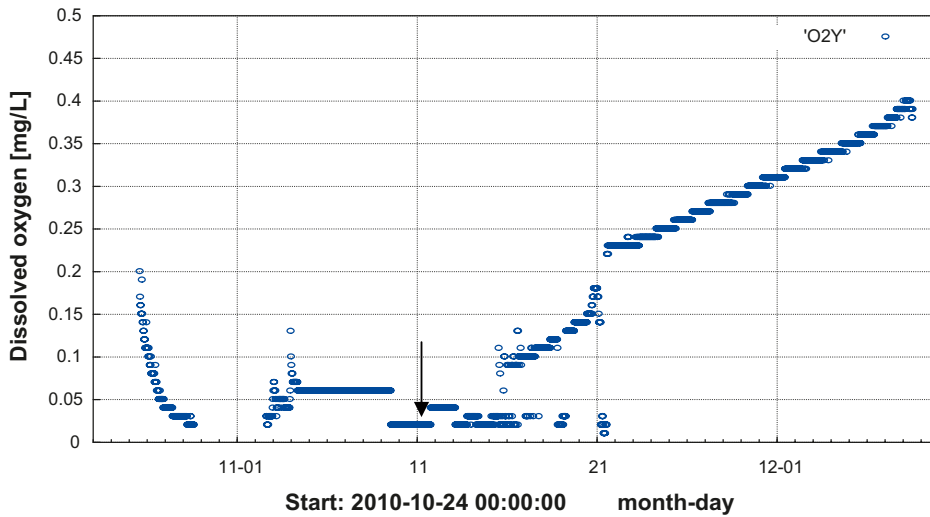
**Figure A6-1.** Redox potential measurements ( $E_h$ ) by gold, glassy carbon and platinum electrodes (EHAUY, EHCY and EHPTY). The arrow shows the selected representative  $E_h$  value for the borehole section. The irregularities at the end of the measurements were caused by pressure changes when the gas sample was collected.



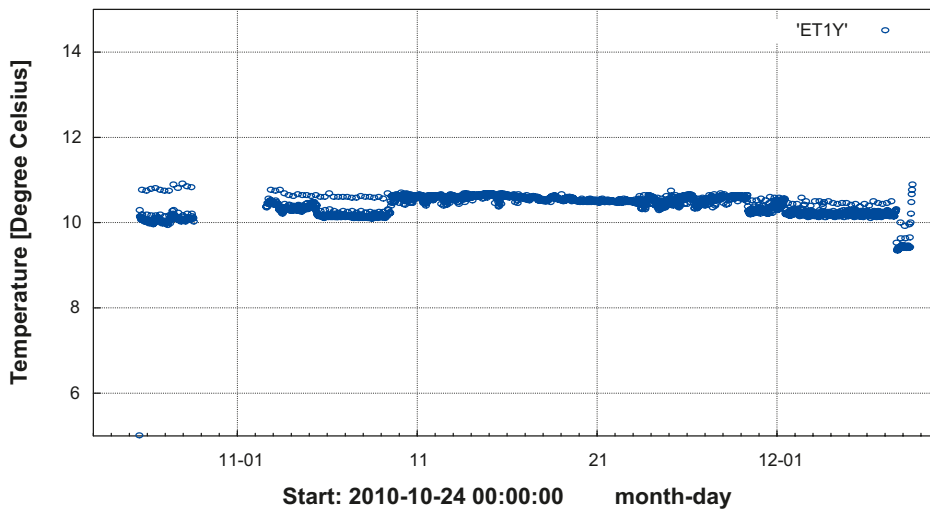
**Figure A6-2.** Measurements of pH by one glass electrode (PHY). The results from electrode PHLY were omitted due to erroneous results. The laboratory pH in the collected sample (PHL<sub>LAB</sub>) is given for comparison. The arrow shows the selected representative pH value for the borehole section. The irregularities at the end of the measurements were caused by pressure changes when the gas sample was collected.



**Figure A6-3.** Electrical conductivity measurements (KONDY). The corresponding laboratory value (KOND\_LAB) is given for comparison. The arrow shows the selected representative electrical conductivity value for the borehole section.



**Figure A6-4.** Dissolved oxygen measurements (O2Y). The arrow shows the selected representative oxygen value for the borehole section. The value by the end of the measurements is not reliable.



**Figure A6-5.** Water temperature in the measurement cell (ET1Y).



## Appendix 7

**Table A7-1. Water Composition.**

Idcode	Secup m	Seclow m	Sample no.	Sampling date	Charge Bal %	Na mg/L	K mg/L	Ca mg/L	Mg mg/L	HCO <sub>3</sub> <sup>-</sup> mg/L	Cl <sup>-</sup> mg/L	SO <sub>4</sub> <sup>2-</sup> mg/L	SO <sub>4</sub> -S mg/L	Br <sup>-</sup> mg/l	F <sup>-</sup> mg/L	Si mg/L
KFR01	11.0	43.5	16922	2010-12-02	-2.02	1,310	13.1	386	110	134	2,760	380	144	9.49	1.39	6.18
KFR01	44.5	62.3	16886	2010-12-03	-0.87	1,430	8.83	611	131	108	3,370	368	138	11.4	1.10	5.34
KFR02	43.0	80.0	16883	2010-11-30	-1.18	1,150	5.17	999	93.1	56.4	3,740	173	64.8	15.0	1.19	5.92
KFR02	81.0	118.0	16884	2010-12-01	-1.35	1,380	6.86	1,190	140	76.5	4,470	332	119	16.8	1.28	6.16
KFR02	119.0	136.0	16885	2010-12-01	0.00	1,470	7.16	1,210	147	81.1	4,520	343	129	16.4	1.34	6.13
KFR02	137.0	170.3	16887	2010-12-02	-1.80	1,460	7.10	1,170	160	85.2	4,610	395	143	16.5	1.35	5.36
KFR03	5.2	44.2	16913	2010-11-24	-1.23	1,020	6.54	747	91.1	69.8	3,080	158	58.1	12.2	1.32	6.35
KFR03	45.2	56.2	16902	2010-11-24	-1.75	1,110	7.18	992	108	66.4	3,760	170	61.5	15.0	1.00	5.94
KFR03	57.2	80.2	16915	2010-11-26	-1.87	1,250	6.61	976	112	69.0	3,930	218	76.9	15.6	1.30	5.87
KFR04	28.0	43.0	16910	2010-11-24	-0.01	1,240	7.42	949	110	75.2	3,720	187	71.6	13.7	1.36	6.36
KFR04	44.0	83.0	16912	2010-11-24	-1.47	1,630	10.5	772	148	102	4,100	356	130	15.0	1.36	5.63
KFR04	84.0	100.5	16909	2010-11-24	-2.06	1,610	10.8	753	144	103	4,080	350	127	14.9	1.73	5.55
KFR05	57.0	79.0	16920	2010-12-03	-0.51	1,620	15.6	566	156	110	3,630	386	140	12.9	1.51	5.65
KFR08	6.0	35.0	16898	2010-11-18	-1.23	1,400	18.1	292	138	127	2,790	357	137	9.37	1.18	6.23
KFR08	36.0	62.0	16897	2010-11-18	-1.40	1,290	7.51	439	112	123	2,830	338	127	9.67	1.34	6.26
KFR08	63.0	104.0	16938	2010-12-07	-2.15	1,410	16.4	439	139	114	3,130	396	147	10.7	1.39	5.94
KFR08	63.0	104.0	16934	2010-12-16	-0.33	1,400	17.1	457	143	117	3,040	402	143	10.7	1.48	5.80
KFR08	63.0	104.0	16943	2010-12-20	-0.92	1,400	17.2	451	144	119	3,080	404	141	10.8	1.44	5.72
KFR09	0.0	80.2	16924	2010-12-03	-1.39	1,510	37.6	170	159	134	2,820	392	144	9.74	1.07	4.88
KFR10	0.0	107.3	16933	2010-12-03	-2.57	1,590	15.4	819	203	131	4,290	376	172	11.6	1.31	6.16
KFR101	279.5	341.8	16942	2010-12-17	-1.18	739	5.15	406	32.4	64.7	1,930	48.8	17.3	10.7	1.60	5.43
KFR105	265.0	306.8	16918	2010-12-03	-3.63	1,170	6.47	756	104	82.4	3,480	252	86.1	13.0	1.53	5.35
KFR13	4.0	33.0	16916	2010-11-26	-1.16	1,330	6.45	992	96.9	81.3	3,970	224	81.5	15.6	1.25	5.60
KFR13	34.0	53.0	16914	2010-11-24	-1.33	1,330	5.60	1,020	95.3	76.4	4,010	254	89.0	15.5	1.16	5.61
KFR13	54.0	76.6	16911	2010-11-24	0.03	1,560	9.37	948	129	80.3	4,180	300	111	16.3	1.45	5.73
KFR19	66.8	76.6	16936	2010-12-09	-3.08	1,330	8.49	314	113	121	2,770	356	131	9.29	1.50	6.37
KFR19	77.6	94.6	16935	2010-12-09	-1.89	1,390	11.1	311	119	119	2,790	363	138	9.42	1.61	6.57
KFR19	95.6	110.0	16878	2010-10-28	-0.26	1,370	9.80	385	110	115	2,780	335	132	9.32	1.50	6.89
KFR19	95.6	110.0	16892	2010-11-09	-0.61	1,370	9.90	362	109	117	2,750	350	136	9.49	1.48	6.99
KFR19	95.6	110.0	16937	2010-12-07	-1.66	1,350	9.31	366	111	122	2,790	357	136	9.44	1.46	7.05
KFR55	8.0	21.0	16901	2010-11-19	-2.34	1,390	8.49	801	123	93.1	3,840	279	102	14.2	1.42	5.93
KFR55	22.0	39.0	16899	2010-11-19	-1.02	1,640	10.2	771	149	104	4,080	358	130	15.1	1.19	5.71
KFR55	40.0	48.0	16891	2010-11-19	-2.18	1,520	9.59	730	140	98.5	3,910	334	122	14.2	1.41	5.89

- = Not analysed

< "value" = below detection limit

ChargeBal % = Rel. charge balance error %

SICADA: water\_composition

Table A7-1. Water Composition.

Idcode	Secup m	Seclow m	Sample no.	Fe mg/L	Fe-tot mg/L	Fe(II) mg/L	Mn mg/L	Li mg/L	Sr mg/L	I <sup>-</sup> mg/L	pH field	pH lab	DOC mg/L	TOC mg/L	HS <sup>-</sup> mg/L
KFR01	11.0	43.5	16922	0.402	-	-	0.990	0.0399	4.81	-	7.54	7.54	-	-	0.019
KFR01	44.5	62.3	16886	0.470	-	-	0.756	0.0600	8.20	0.0661	7.61	7.61	3.0	1.4	<0.019
KFR02	43.0	80.0	16883	0.418	0.419	0.403	0.516	0.0635	15.3	0.106	7.75	7.75	0.7	0.7	0.021
KFR02	81.0	118.0	16884	1.03	1.06	1.03	1.02	0.0720	17.4	0.148	7.66	7.66	1.1	0.9	<0.019
KFR02	119.0	136.0	16885	1.57	1.56	1.56	1.27	0.0589	17.4	0.160	7.61	7.61	1.0	1.0	<0.019
KFR02	137.0	170.3	16887	3.84	-	-	1.51	0.0663	16.0	0.192	7.42	7.42	1.1	1.1	-
KFR03	5.2	44.2	16913	1.25	-	-	1.36	0.0498	11.6	-	7.64	7.64	-	-	<0.019
KFR03	45.2	56.2	16902	1.47	-	-	2.07	0.0793	14.6	-	7.69	7.69	-	-	0.043
KFR03	57.2	80.2	16915	1.43	-	-	2.29	0.0682	14.4	-	7.56	7.56	-	-	0.089
KFR04	28.0	43.0	16910	0.923	-	-	0.672	0.0675	14.7	-	7.50	7.50	-	-	0.021
KFR04	44.0	83.0	16912	1.53	-	-	1.19	0.0635	10.7	-	7.64	7.64	-	-	0.031
KFR04	84.0	100.5	16909	1.86	-	-	1.19	0.0612	9.87	-	7.67	7.67	-	-	<0.019
KFR05	57.0	79.0	16920	2.07	-	-	1.22	0.0460	6.99	-	7.64	7.64	-	-	<0.019
KFR08	6.0	35.0	16898	0.467	-	-	0.77	0.0335	3.36	-	7.49	7.49	-	-	0.023
KFR08	36.0	62.0	16897	0.427	-	-	0.691	0.0415	5.94	-	7.51	7.51	-	-	0.026
KFR08	63.0	104.0	16938	2.00	-	-	1.29	0.0400	4.80	-	-	-	-	-	0.025
KFR08	63.0	104.0	16934	2.06	-	-	1.31	0.0479	4.92	-	-	-	-	-	0.020
KFR08	63.0	104.0	16943	2.02	1.96	1.93	1.29	0.0397	4.90	0.0234	7.30	7.30	1.7	1.7	<0.019
KFR09	0.0	80.2	16924	1.36	-	-	0.667	0.0270	2.00	-	7.72	7.72	-	-	<0.019
KFR10	0.0	107.3	16933	4.28	-	-	3.17	0.0585	8.46	-	7.45	7.45	-	-	<0.019
KFR101	279.5	341.8	16942	0.286	-	-	0.527	0.0306	5.99	-	7.85	7.85	2.3	2.5	0.130
KFR105	265.0	306.8	16918	0.748	-	-	1.60	0.0489	11.5	-	7.72	7.72	-	-	<0.019
KFR13	4.0	33.0	16916	2.44	-	-	0.705	0.0621	15.1	-	7.61	7.61	-	-	0.066
KFR13	34.0	53.0	16914	0.877	-	-	0.58	0.0638	15.6	-	7.86	7.86	-	-	0.050
KFR13	54.0	76.6	16911	1.55	-	-	1.10	0.0730	13.5	-	7.67	7.67	-	-	<0.019
KFR19	66.8	76.6	16936	0.315	-	-	0.693	0.0354	3.81	-	7.71	7.71	-	-	-
KFR19	77.6	94.6	16935	0.677	-	-	0.867	0.0260	3.90	-	7.81	7.81	-	-	0.037
KFR19	95.6	110.0	16878	0.913	-	-	0.866	0.0351	5.29	-	-	-	2.6	3.0	<0.019
KFR19	95.6	110.0	16892	1.22	-	-	0.860	0.0352	4.94	-	-	-	2.1	2.0	0.027
KFR19	95.6	110.0	16937	1.10	0.957	0.932	0.917	0.0339	4.62	0.0130	7.67	7.67	2.2	2.0	0.030
KFR55	8.0	21.0	16901	0.735	-	-	0.780	0.0622	12.1	-	7.68	7.68	-	-	<0.019
KFR55	22.0	39.0	16899	1.45	-	-	1.27	0.0492	10.6	-	7.45	7.45	-	-	<0.019
KFR55	40.0	48.0	16891	1.31	-	-	1.15	0.0592	9.87	-	7.76	7.76	-	-	<0.019

- = Not analysed

&lt; "value" = below detection limit

ChargeBal % = Rel. charge balance error %

SICADA: water\_composition

Table A7-1. Water Composition.

Idcode	Secup m	Seclow m	Sample no.	EICond mS/m field	EICond mS/m lab	NH <sub>4</sub> -N mg/L	NO <sub>2</sub> -N mg/L	NO <sub>3</sub> -N mg/L	NO <sub>2</sub> -N+NO <sub>3</sub> -N mg/L	PO <sub>4</sub> -P mg/L	P mg/L	Temperature (°C) field
KFR01	11.0	43.5	16922	922	873	-	-	-	-	-	-	9.5
KFR01	44.5	62.3	16886	1,045	1,030	0.223	<0.0002	<0.0003	<0.0003	<0.0005	<0.005	8.7
KFR02	43.0	80.0	16883	1,074	1,090	0.0067	<0.0002	0.0021	0.0022	<0.0005	<0.005	11.0
KFR02	81.0	118.0	16884	1,307	1,310	0.0122	<0.0002	<0.0003	<0.0003	<0.0005	<0.005	10.4
KFR02	119.0	136.0	16885	1,322	1,310	0.0193	<0.0002	<0.0003	<0.0003	<0.0005	<0.005	10.2
KFR02	137.0	170.3	16887	1,352	1,350	0.0240	<0.0002	0.0015	0.0014	<0.0005	<0.005	10.6
KFR03	5.2	44.2	16913	929	908	-	-	-	-	-	-	10.8
KFR03	45.2	56.2	16902	1,099	1,090	-	-	-	-	-	-	10.7
KFR03	57.2	80.2	16915	1,172	1,160	-	-	-	-	-	-	9.8
KFR04	28.0	43.0	16910	1,101	1,090	-	-	-	-	-	-	10.4
KFR04	44.0	83.0	16912	1,239	1,220	-	-	-	-	-	-	10.6
KFR04	84.0	100.5	16909	1,222	1,220	-	-	-	-	-	-	10.8
KFR05	57.0	79.0	16920	1,102	1,100	-	-	-	-	-	-	11.0
KFR08	6.0	35.0	16898	876	878	-	-	-	-	-	-	9.7
KFR08	36.0	62.0	16897	886	890	-	-	-	-	-	-	9.7
KFR08	63.0	104.0	16938	-	987	-	-	-	-	-	-	-
KFR08	63.0	104.0	16934	-	969	-	-	-	-	-	-	-
KFR08	63.0	104.0	16943	-	971	0.287	<0.0002	0.0006	0.0007	<0.0005	<0.005	-
KFR09	0.0	80.2	16924	902	894	-	-	-	-	-	-	8.3
KFR10	0.0	107.3	16933	1,278	1,270	-	-	-	-	-	-	8.4
KFR101	279.5	341.8	16942	616	599	-	-	-	-	-	<0.005	7.5
KFR105	265.0	306.8	16918	1,049	1,040	-	-	-	-	-	-	8.4
KFR13	4.0	33.0	16916	1,173	1,170	-	-	-	-	-	-	10.0
KFR13	34.0	53.0	16914	1,186	1,170	-	-	-	-	-	-	9.7
KFR13	54.0	76.6	16911	1,241	1,220	-	-	-	-	-	-	9.4
KFR19	66.8	76.6	16936	889	880	-	-	-	-	-	-	10.0
KFR19	77.6	94.6	16935	885	875	-	-	-	-	-	-	10.8
KFR19	95.6	110.0	16878	-	885	-	-	-	-	-	-	-
KFR19	95.6	110.0	16892	-	884	-	-	-	-	-	-	-
KFR19	95.6	110.0	16937	-	891	0.0594	<0.0002	0.0015	0.0015	<0.0005	<0.005	-
KFR55	8.0	21.0	16901	1,152	1,140	-	-	-	-	-	-	10.0
KFR55	22.0	39.0	16899	1,176	1,210	-	-	-	-	-	-	9.9
KFR55	40.0	48.0	16891	1,173	1,170	-	-	-	-	-	-	10.0

- = Not analysed

&lt; "value" = below detection limit

ChargeBal % = Rel. charge balance error %

SICADA: water\_composition

**Table A7-1. Water Composition.**

Idcode	Secup m	Seclow m	Sample no.	Sampling date	Charge Bal %	Na mg/L	K mg/L	Ca mg/L	Mg mg/L	HCO <sub>3</sub> <sup>-</sup> mg/L	Cl <sup>-</sup> mg/L	SO <sub>4</sub> <sup>2-</sup> mg/L	SO <sub>4</sub> -S mg/L	Br <sup>-</sup> mg/l	F <sup>-</sup> mg/L	Si mg/L
KFR56	9.0	81.7	16900	2010-11-19	-1.91	1,380	25.5	292	139	129	2,810	348	136	9.15	1.07	6.22
KFR7A	2.0	19.0	16921	2010-12-03	-1.01	1,580	24.9	340	154	119	3,180	399	151	11.0	1.42	5.39
KFR7A	48.0	74.7	16879	2010-10-29	-2.08	1,470	14.7	632	169	113	3,670	386	143	12.3	1.61	5.99
KFR7A	48.0	74.7	16882	2010-11-12	-1.25	1,510	15.1	636	170	113	3,680	385	146	12.3	1.46	6.10
KFR7A	48.0	74.7	16917	2010-11-30	-4.46	1,410	13.9	593	158	113	3,670	405	138	12.7	1.52	5.75
KFR7B	4.0	7.0	16919	2010-12-02	-0.97	1,600	28.6	324	161	121	3,190	399	154	11.0	1.39	5.19
KFR7B	8.6	21.1	16923	2010-12-02	-0.88	1,610	35.0	280	165	121	3,150	400	148	10.9	1.19	4.79
PFR000121			16941	2010-12-16	-	-	-	-	-	119	-	-	-	-	-	-

- = Not analysed

< "value" = below detection limit

ChargeBal % = Rel. charge balance error %

SICADA: water\_composition

**Table A7-1. Water Composition.**

Idcode	Secup m	Seclow m	Sample no.	Fe mg/L	Fe-tot mg/L	Fe(II) mg/L	Mn mg/L	Li mg/L	Sr mg/L	I <sup>-</sup> mg/L	pH field	pH lab	DOC mg/L	TOC mg/L	HS <sup>-</sup> mg/L
KFR56	9.0	81.7	16900	0.497	-	-	0.479	0.0329	3.57	-	7.73	7.73	-	-	0.025
KFR7A	2.0	19.0	16921	1.88	-	-	0.963	0.0357	4.11	-	7.62	7.62	-	-	<0.019
KFR7A	48.0	74.7	16879	2.62	-	-	1.56	<0.04	7.32	-	-	-	1.5	1.6	<0.019
KFR7A	48.0	74.7	16882	2.66	-	-	1.58	0.0534	7.42	-	-	-	1.5	1.4	<0.019
KFR7A	48.0	74.7	16917	2.49	-	-	1.47	0.0487	6.92	0.199	7.37	7.37	1.6	1.5	<0.019
KFR7B	4.0	7.0	16919	1.68	-	-	0.959	0.0371	4.03	-	7.71	7.71	-	-	<0.019
KFR7B	8.6	21.1	16923	1.64	-	-	0.800	0.0335	3.29	-	7.68	7.68	-	-	<0.019
PFR000121			16941	-	-	-	-	-	-	-	-	-	-	-	-

- = Not analysed

< "value" = below detection limit

ChargeBal % = Rel. charge balance error %

SICADA: water\_composition

**Table A7-1. Water Composition.**

Idcode	Secup m	Seclow m	Sample no.	EICond mS/m field	EICond mS/m lab	NH <sub>4</sub> -N mg/L	NO <sub>2</sub> -N mg/L	NO <sub>3</sub> -N mg/L	NO <sub>2</sub> -N+NO <sub>3</sub> -N mg/L	PO <sub>4</sub> -P mg/L	P mg/L	Temperature (°C) field
KFR56	9.0	81.7	16900	930	885	-	-	-	-	-	-	10.5
KFR7A	2.0	19.0	16921	1,013	982	-	-	-	-	-	-	10.0
KFR7A	48.0	74.7	16879	-	1,130	-	-	-	-	-	-	-
KFR7A	48.0	74.7	16882	-	1,110	-	-	-	-	-	-	-
KFR7A	48.0	74.7	16917	-	1,120	0.258	<0.0002	0.005	0.005	<0.0005	<0.005	-
KFR7B	4.0	7.0	16919	1,009	989	-	-	-	-	-	-	9.9
KFR7B	8.6	21.1	16923	1,002	986	-	-	-	-	-	-	9.7
PFR000121			16941	-	961	-	-	-	-	-	-	-

- = Not analysed

< "value" = below detection limit

ChargeBal % = Rel. charge balance error %

SICADA: water\_composition

**Table A7-2. Trace elements.**

Idcode	Secup m	Seclow m	Sample no.	Sampling date	U mg/L	Th mg/L	As mg/L	Sc mg/L	Cd mg/L	Hg mg/L	V mg/L	Rb mg/L	Y mg/L	Zr mg/L	In mg/L	Cs mg/L	Ba mg/L
KFR01	44.5	62.3	16886	2010-12-03	2.75	<0.2	<0.5	<0.4	<0.02	<0.002	0.0613	14.6	5.08	0.199	<0.2	0.441	55.2
KFR02	43.0	80.0	16883	2010-11-30	17.3	<0.2	<0.5	<0.4	<0.02	<0.002	0.0622	13.0	7.69	0.104	<0.2	0.721	129
KFR02	81.0	118.0	16884	2010-12-01	14.1	<0.2	<0.5	<0.4	<0.02	<0.002	0.0395	16.4	12.4	<0.1	<0.2	0.641	138
KFR02	119.0	136.0	16885	2010-12-01	11.7	<0.2	<0.5	<0.4	<0.02	<0.002	0.0463	18.3	14.5	0.108	<0.2	0.643	158
KFR02	137.0	170.3	16887	2010-12-02	14.7	<0.2	<0.5	<0.4	<0.02	<0.002	0.0841	17.7	8.00	<0.1	<0.2	0.604	119
KFR08	62.95	104.0	16938	2010-12-07	9.42	<0.2	-	-	-	-	-	-	-	-	-	-	-
KFR08	62.95	104.0	16934	2010-12-16	9.22	<0.2	-	-	-	-	-	-	-	-	-	-	-
KFR08	62.95	104.0	16943	2010-12-20	9.10	<0.2	<0.3	<0.4	<0.02	<0.002	0.0489	20.7	7.57	0.150	<0.2	0.682	33.5
KFR101	279.5	341.8	16942	2010-12-17	35.2	<0.2	-	<0.4	<0.02	<0.002	0.0308	11.8	2.15	<0.1	-	0.294	-
KFR19	95.6	110.0	16878	2010-10-28	9.28	<0.2	-	-	-	-	-	-	-	-	-	-	-
KFR19	95.6	110.0	16892	2010-11-09	9.63	<0.2	-	-	-	-	-	-	-	-	-	-	-
KFR19	95.6	110.0	16937	2010-12-07	9.93	<0.2	<1	<0.4	<0.02	<0.002	0.11	19.0	0.693	0.954	<0.2	0.591	75.7
KFR7A	48.0	74.7	16879	2010-10-29	8.47	<0.2	-	-	-	-	-	-	-	-	-	-	-
KFR7A	48.0	74.7	16882	2010-11-12	8.25	<0.2	-	-	-	-	-	-	-	-	-	-	-
KFR7A	48.0	74.7	16917	2010-11-30	8.19	<0.2	<0.5	<0.4	<0.02	<0.002	0.0347	24.3	8.89	0.168	<0.2	0.728	35.9

< "value" = below detection limit

- = not analysed

SICADA: trace\_elements

Table A7-2. Trace elements.

Idcode	Secup m	Seclow m	Sample no.	La mg/L	Hf mg/L	Tl mg/L	Ce mg/L	Pr mg/L	Nd mg/L	Sm mg/L	Eu mg/L	Gd mg/L	Tb mg/L	Dy mg/L	Ho mg/L	Er mg/L	Tm mg/L	Yb mg/L	Lu mg/L
KFR01	44.5	62.3	16886	0.132	<0.2	<0.05	0.140	<0.02	0.122	0.0357	<0.02	0.108	0.0214	0.211	0.0736	0.280	0.0349	0.221	0.0367
KFR02	43.0	80.0	16883	0.257	<0.2	<0.05	0.503	0.0734	0.417	0.168	<0.02	0.354	0.0537	0.400	0.106	0.329	0.0389	0.228	0.0362
KFR02	81.0	118.0	16884	0.201	<0.2	<0.05	0.450	0.0701	0.428	0.179	0.0206	0.430	0.075	0.603	0.196	0.662	0.0842	0.523	0.0832
KFR02	119.0	136.0	16885	0.308	<0.2	<0.05	0.639	0.0902	0.516	0.221	0.0203	0.523	0.0908	0.724	0.212	0.720	0.0878	0.526	0.0862
KFR02	137.0	170.3	16887	0.109	<0.2	<0.05	0.171	<0.02	0.107	0.0416	<0.02	0.123	0.023	0.227	0.081	0.302	0.0389	0.230	0.0417
KFR08	62.95	104.0	16938	-	-	-	-	-	-	-	-	-	-	-	-	-	-	-	-
KFR08	62.95	104.0	16934	-	-	-	-	-	-	-	-	-	-	-	-	-	-	-	-
KFR08	62.95	104.0	16943	0.0964	<0.02	<0.05	0.218	0.0282	0.170	0.0908	<0.02	0.296	0.057	0.459	0.137	0.449	0.0535	0.321	0.0529
KFR101	279.5	341.8	16942	0.0677	<0.2	<0.05	0.152	<0.02	0.0575	0.0230	<0.02	0.0554	<0.02	0.0895	0.0294	0.0998	<0.02	0.0892	<0.02
KFR19	95.6	110.0	16878	-	-	-	-	-	-	-	-	-	-	-	-	-	-	-	-
KFR19	95.6	110.0	16892	-	-	-	-	-	-	-	-	-	-	-	-	-	-	-	-
KFR19	95.6	110.0	16937	0.100	0.0208	<0.05	0.182	0.0221	0.0921	0.0220	<0.02	0.0367	<0.02	0.044	<0.02	0.0453	<0.02	0.0343	<0.02
KFR7A	48.0	74.7	16879	-	-	-	-	-	-	-	-	-	-	-	-	-	-	-	-
KFR7A	48.0	74.7	16882	-	-	-	-	-	-	-	-	-	-	-	-	-	-	-	-
KFR7A	48.0	74.7	16917	0.0875	<0.02	<0.05	0.198	0.0248	0.151	0.0599	<0.02	0.231	0.0577	0.505	0.159	0.524	0.0695	0.442	0.0682

< "value" = below detection limit

- = not analysed

SICADA: trace\_elements



Table A7-3. Isotopes I (H-, O-, B-, S-, Cl- and C-isotopes).

Idcode	Secup m	Seclow m	Sample no	Sampling date	$\delta^2\text{H}$ dev SMOW*	$^3\text{H}$ TU*	$\delta^{18}\text{O}$ dev SMOW	$^{10}\text{B}/^{11}\text{B}$ no unit	$\delta^{34}\text{S}$ dev CDT*	$\delta^{13}\text{C}$ dev PDB*	$^{87}\text{Sr}/^{86}\text{Sr}$ no unit	$^{14}\text{C}$ pmC*	$\delta^{37}\text{Cl}$ dev SMOC*	$\delta^{36}\text{Cl}$ $^{36}\text{Cl}/\text{Total Cl}$ (E-15)
KFR01	11.0	43.5	16922	2010-12-02	-74.1	9.4	-8.8	-	-	-	-	-	-	-
KFR01	44.5	62.3	16886	2010-12-03	-78.6	5.2	-9.8	0.2378	24.2	-7.7	0.716568	20.4	A	-
KFR02	43.0	80.0	16883	2010-11-30	-112.6	1.8	-14.9	0.2363	26.5	-12.4	0.716272	4.7	A	-
KFR02	81.0	118	16884	2010-12-01	-92.0	2.0	-11.9	0.2368	26.7	-9.4	0.716398	4.9	A	-
KFR02	119.0	136.0	16885	2010-12-01	-90.3	1.7	-11.6	0.2372	25.8	-11.9	0.716548	6.2	A	-
KFR02	137.0	170.3	16887	2010-12-02	-84.8	**	-10.7	0.2379	25.6	-8.6	0.716470	6.9	A	-
KFR03	5.2	44.2	16913	2010-11-24	-111.7	3.2	-14.9	-	-	-	-	-	-	-
KFR03	45.2	56.2	16902	2010-11-24	-111.4	1.3	-14.6	-	-	-	-	-	-	-
KFR03	57.2	80.2	16915	2010-11-26	-102.7	**	-13.4	-	-	-	-	-	-	-
KFR04	28.0	43.0	16910	2010-11-24	-100.3	**	-13.3	-	-	-	-	-	-	-
KFR04	44.0	83.0	16912	2010-11-24	-82.6	2.6	-10.4	-	-	-	-	-	-	-
KFR04	84.0	100.5	16909	2010-11-24	-84.0	2.1	-10.4	-	-	-	-	-	-	-
KFR05	57.0	79.0	16920	2010-12-03	-74.7	4.4	-9.5	-	-	-	-	-	-	-
KFR08	6.0	35.0	16898	2010-11-18	-70.6	9.7	-8.4	-	-	-	-	-	-	-
KFR08	36.0	62.0	16897	2010-11-18	-69.3	9.6	-8.9	-	-	-	-	-	-	-
KFR08	63.0	104.0	16938	2010-12-07	-71.3	6.9	-8.7	-	-	-	-	-	-	14
KFR08	63.0	104.0	16934	2010-12-16	-71.4	7.9	-8.6	-	-	-	-	-	-	-
KFR08	63.0	104.0	16943	2010-12-20	-70.8	7.2	-8.5	0.2383	21.9	-6.1	0.716552	48.0	0.24	-
KFR09	0.0	80.2	16924	2010-12-03	-70.2	8.9	-8.2	-	-	-	-	-	-	-
KFR10	0.0	107.3	16933	2010-12-03	-72.4	3.8	-8.4	-	-	-	-	-	-	-
KFR101	279.5	341.8	16942	2010-12-17	-108.6	<0.8	-15.0	-	44.6	-	-	-	-	27
KFR105	265.0	306.8	16918	2010-12-03	-103.3	1.2	-13.9	-	-	-	-	-	-	25
KFR13	4.0	33.0	16916	2010-11-26	-105.2	**	-13.5	-	-	-	-	-	-	-
KFR13	34.0	53.0	16914	2010-11-24	-94.9	1.8	-13.0	-	-	-	-	-	-	-
KFR13	54.0	76.6	16911	2010-11-24	-88.7	2.2	-11.4	-	-	-	-	-	-	-
KFR19	66.8	76.6	16936	2010-12-09	-76.1	**	-8.5	-	-	-	-	-	-	-
KFR19	77.6	94.6	16935	2010-12-09	-74.9	9.7	-8.6	-	-	-	-	-	-	-
KFR19	95.6	110.0	16878	2010-10-28	-73.1	8.9	-8.7	-	-	-	-	-	-	-

\* Units are defined in Appendix 1

\*\* Not analysed due to sampling problems

&lt; "value" = below detection limit

A = Results will be reported later

SICADA: isotopes\_1\_t

Table A7-3. Isotopes I (H-, O-, B-, S-, Cl- and C-isotopes).

Idcode	Secup m	Seclow m	Sample no	Sampling date	$\delta^2\text{H}$ dev SMOW*	$^3\text{H}$ TU*	$\delta^{18}\text{O}$ dev SMOW	$^{10}\text{B}/^{11}\text{B}$ no unit	$\delta^{34}\text{S}$ dev CDT*	$\delta^{13}\text{C}$ dev PDB*	$^{87}\text{Sr}/^{86}\text{Sr}$ no unit	$^{14}\text{C}$ pmC*	$\delta^{37}\text{Cl}$ dev SMOC*	$\delta^{36}\text{Cl}$ $^{36}\text{Cl}/\text{Total Cl}$ (E-15)
KFR19	95.6	110.0	16892	2010-11-09	-72.4	9.9	-8.6	-	-	-	-	-	-	-
KFR19	95.6	110.0	16937	2010-12-07	-73.4	8.0	-8.6	0.2387	21.6	-5.8	0.716472	55.5	-0.17	-
KFR55	8.0	21.0	16901	2010-11-19	-88.8	4.2	-11	-	-	-9.0	-	16.5	-	-
KFR55	22.0	39.0	16899	2010-11-19	-83.6	2.7	-10.2	-	-	-8.9	-	21.4	-	-
KFR55	40.0	48.0	16891	2010-11-19	-82.3	3.6	-10.4	-	-	-7.6	-	24.8	-	-
KFR56	9.0	81.7	16900	2010-11-19	-72.1	10.0	-8.0	-	-	-	-	-	-	-
KFR7A	2.0	19.0	16921	2010-12-03	-70.4	8.0	-8.7	-	-	-	-	-	-	-
KFR7A	48.0	74.7	16879	2010-10-29	-78.3	6.9	-9.1	-	-	-	-	-	-	-
KFR7A	48.0	74.7	16882	2010-11-12	-76.8	6.8	-9.1	-	-	-	-	-	-	-
KFR7A	48.0	74.7	16917	2010-11-30	-78.4	5.5	-9.1	0.2380	23.1	-6.9	0.716579	33.2	-0.03	12
KFR7B	4.0	7.0	16919	2010-12-02	-71.3	6.3	-8.6	-	-	-	-	-	-	-
KFR7B	8.6	21.1	16923	2010-12-02	-71.2	7.5	-8.5	-	-	-	-	-	-	-
PFR000121			16941	2010-12-16	-	-	-	-	-	-6.0	-	2,310	-	-

\* Units are defined in Appendix 1

\*\* Not analysed due to sampling problems

< "value" = below detection limit

A = Results will be reported later

SICADA: isotopes\_1\_t

**Table A7-4. Isotopes II (U-, Th, Ra- and Rn-isotopes).**

Idcode	Secup m	Seclow m	Sample no.	Sampling date	<sup>238</sup> U mBq/L	<sup>235</sup> U mBq/L	<sup>234</sup> U mBq/L	<sup>232</sup> Th mBq/L	<sup>230</sup> Th mBq/L	<sup>226</sup> Ra Bq/L	<sup>222</sup> Rn Bq/L At time of analysis	<sup>222</sup> Rn Bq/L At time of collection
KFR01	44.5	62.3	16886	2010-12-03	32	1.47	171	0.20	0.55	0.836	9.09	97.2
KFR02	43.0	80.0	16883	2010-11-30	181	7.58	941	0.07	0.20	5.95	1,400	5,270
KFR02	81.0	118.0	16884	2010-12-01	161	6.67	648	0.20	0.28	4.94	722	2,790
KFR02	119.0	136.0	16885	2010-12-01	137	5.93	545	0.04	0.32	5.06	1,190	4,160
KFR02	137.0	170.3	16887	2010-12-02	163	6.84	575	0.16	0.26	*	*	*
KFR08	63.0	104.0	16943	2010-12-20	A	A	A	A	A	*	*	*
KFR19	95.6	110.0	16937	2010-12-07	112	4.85	512	0.10	0.72	1.21	419	2,390
KFR7A	48.0	74.7	16917	2010-11-30	96	4.21	411	0.31	0.39	0.935	275	1,170

\* = Not analysed due to sampling problems

A = Results will be reported later

SICADA: u\_th\_isotope\_t, ra\_rn\_isotope\_t

**Table A7-5. Dissolved gases.**

Idcode	Secup m	Seclow m	Sample no.	Sampling date	Ar mL/L	He mL/L	N <sub>2</sub> mL/L	CO <sub>2</sub> mL/L	CH <sub>4</sub> mL/L	O <sub>2</sub> mL/L	H <sub>2</sub> μL/L	C <sub>2</sub> H <sub>6</sub> μL/L	C <sub>2</sub> H <sub>4</sub> μL/L	C <sub>2</sub> H <sub>2</sub> μL/L	C <sub>3</sub> H <sub>8</sub> μL/L	C <sub>3</sub> H <sub>6</sub> μL/L	DISS_GAS mL/L H2O
KFR08	63.0	104.0	16943	2010-12-21	1.4	**	41.5	3.6	0.020	0.11	<1.6	0.07	0.03	<0.03	0.07	<0.05	54.8
KFR08	63.0	104.0	16943*	2010-12-21	1.4*	**	41.1*	3.6*	0.020*	*	<1.6*	0.07*	0.03*	<0.03*	0.07*	<0.05*	54.3*
KFR19	95.6	110.0	16937	2010-12-08	0.29	**	26.5	4.0	0.022	0.46	<1.1	0.30	0.20	0.20	0.10	0.10	37.5
KFR19	95.6	110.0	16937*	2010-12-08	0.27*	**	24.8*	4.0*	0.022*	*	<1.1*	0.30*	0.20*	0.20*	0.10*	0.10*	35.3*

< "value" = result below detection limit

\* = compensated for air intrusion

\*\* Not analysed due to analytical problems

SICADA: Dissolved\_gases

Water chemistry diagrams

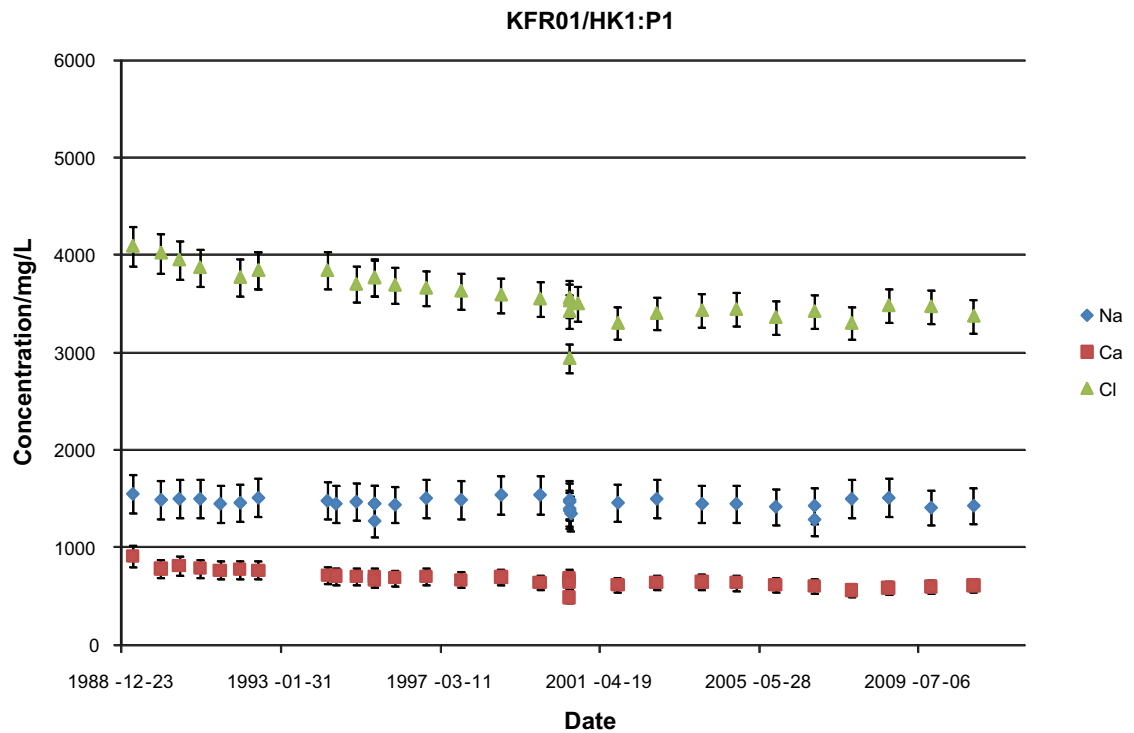


Figure A8-1. KFR01: chloride-, calcium- and sodium concentrations in groundwater samples from 1989 to 2010.

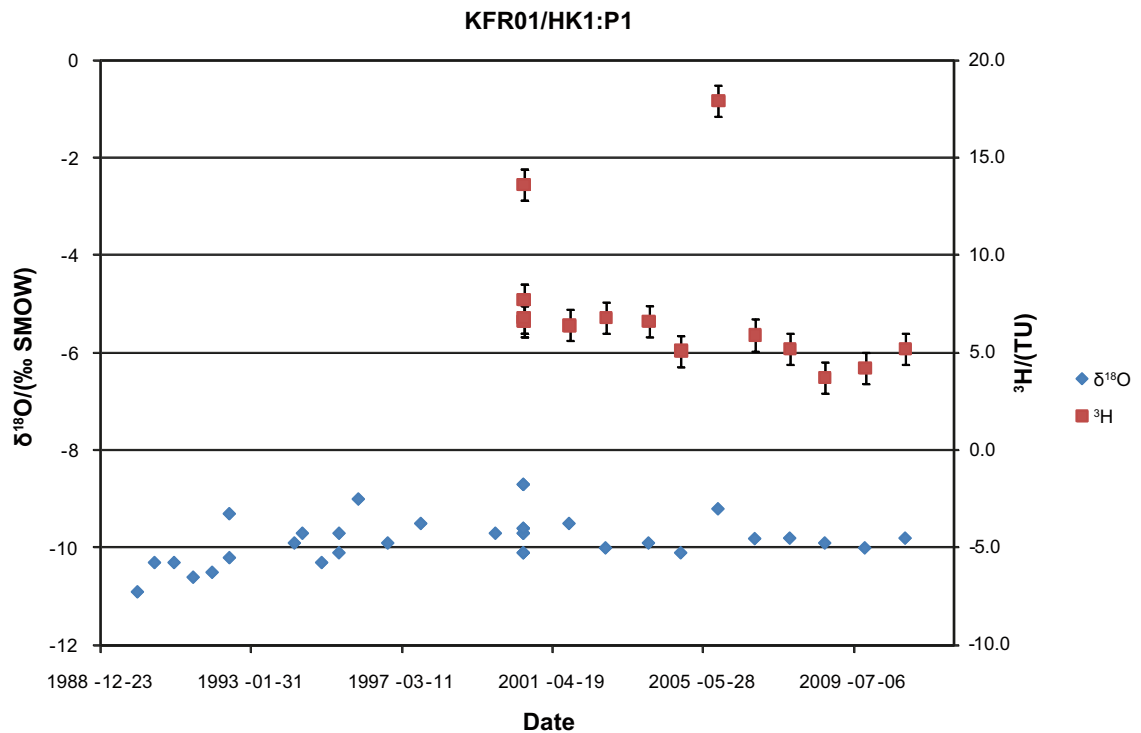
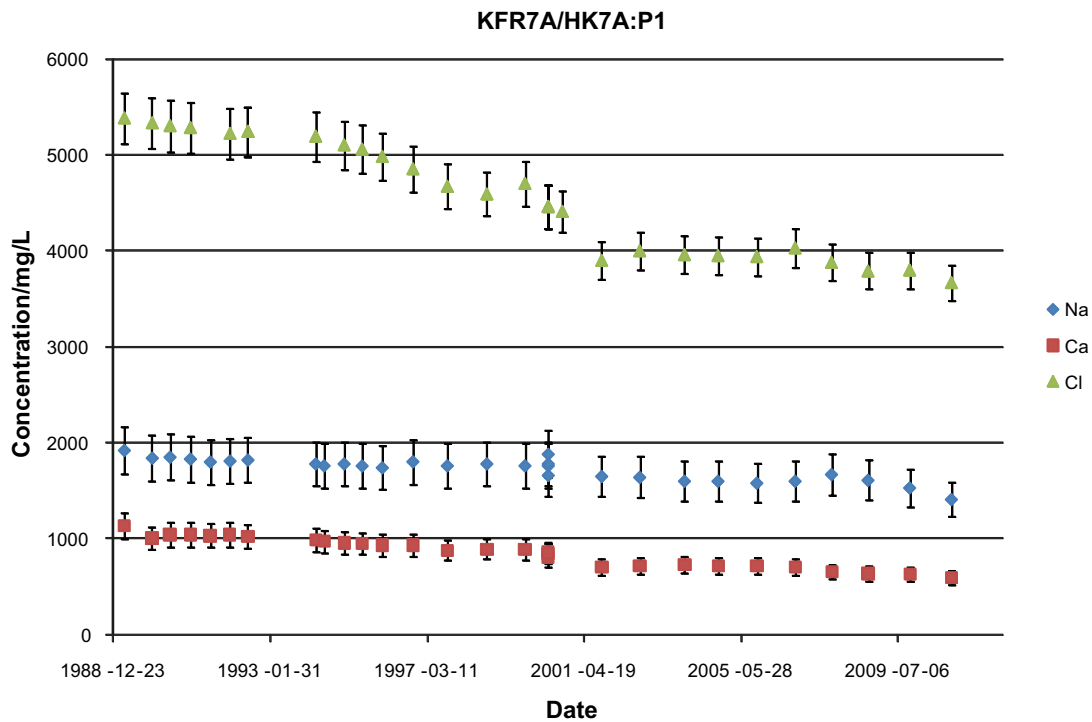
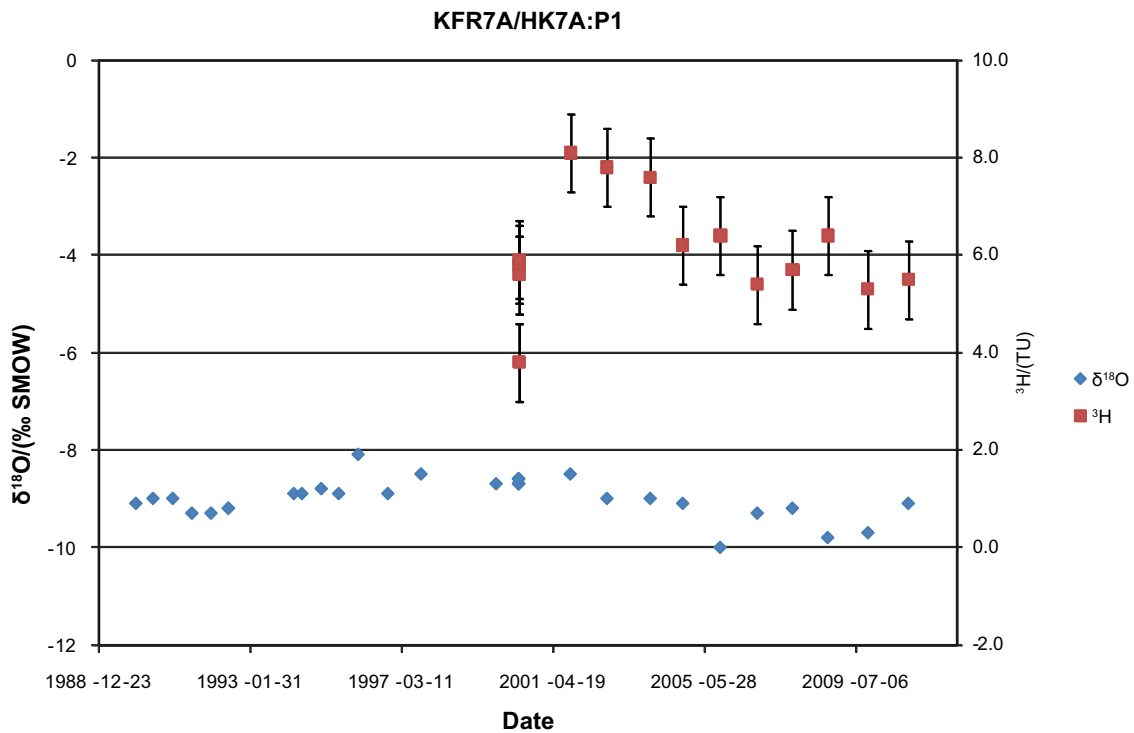


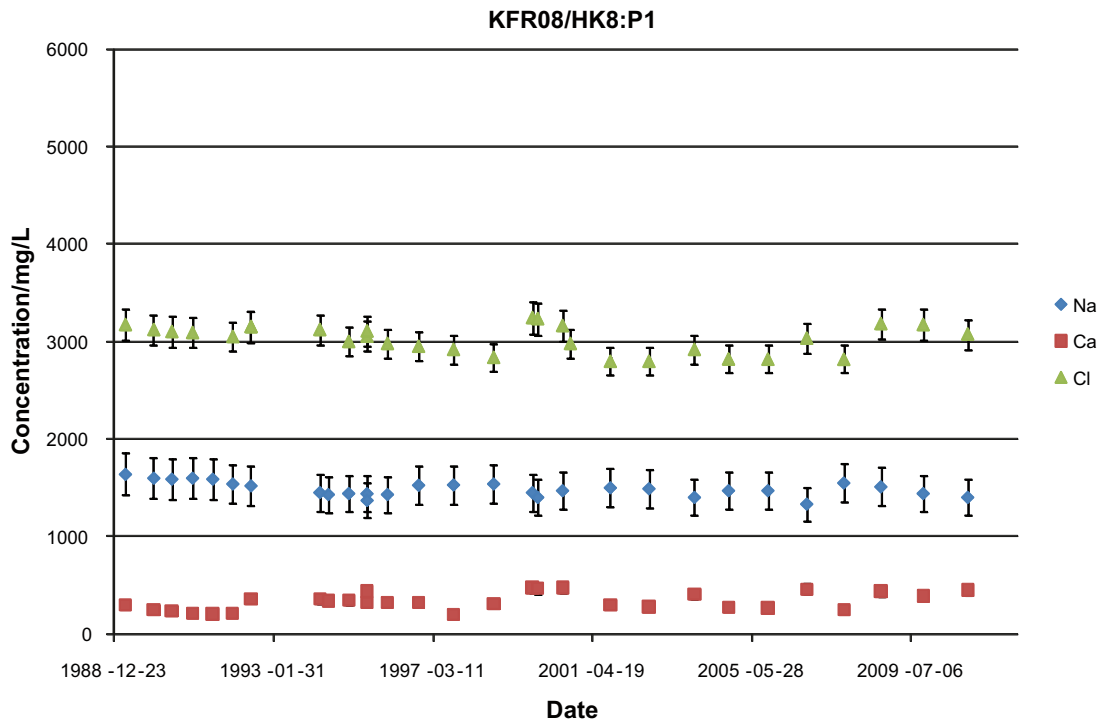
Figure A8-2. KFR01:  $\delta^{18}\text{O}$  and  $^3\text{H}$  values in groundwater samples from 1989 to 2010. The results from tritium analyses of samples taken before 1999 have been considered uncertain and are omitted in the diagram.



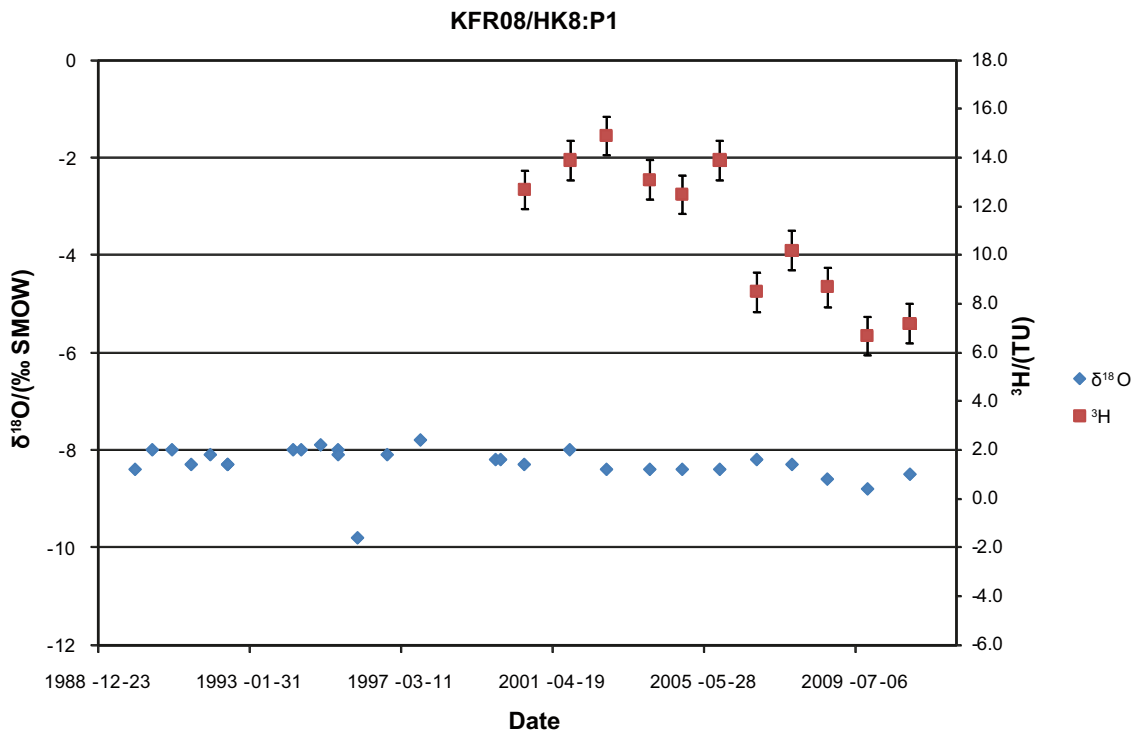
*Figure A8-3. KFR7A: chloride-, calcium- and sodium concentrations in groundwater samples from 1989 to 2010.*



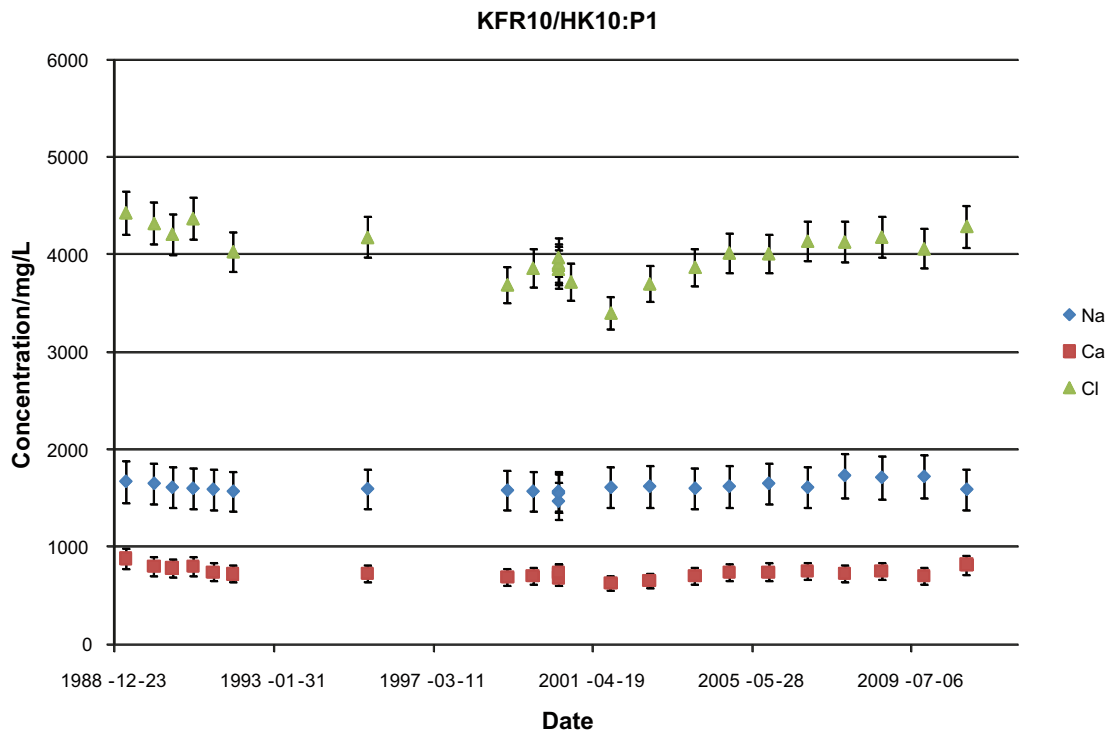
*Figure A8-4. KFR7A: δ<sup>18</sup>O and <sup>3</sup>H values in groundwater samples from 1989 to 2010. The results from tritium analyses of samples taken before 1999 have been considered uncertain and are omitted in the diagram.*



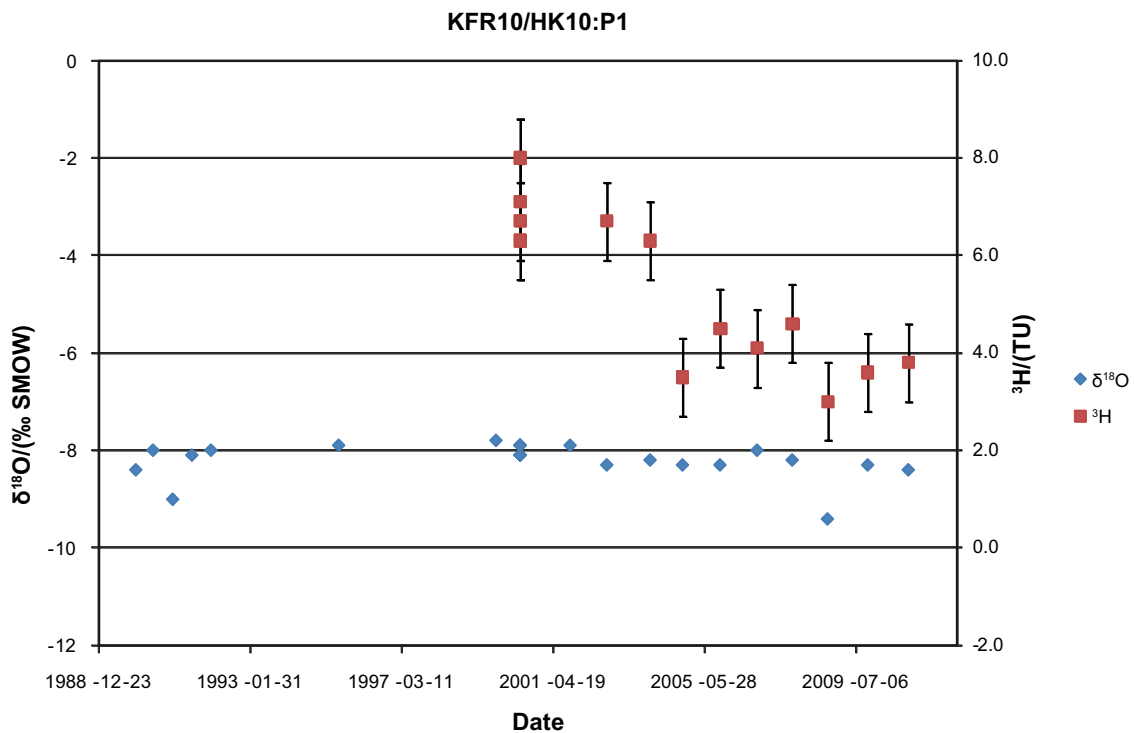
**Figure A8-5.** KFR08: chloride-, calcium- and sodium concentrations in groundwater samples from 1989 to 2010.



**Figure A8-6.** KFR08:  $\delta^{18}\text{O}$  and  $^3\text{H}$  values in groundwater samples from 1989 to 2010. The results from tritium analyses of samples taken before 1999 have been considered uncertain and are omitted in the diagram.



*Figure A8-7. KFR10: chloride-, calcium- and sodium concentrations in groundwater samples from 1989 to 2010.*



*Figure A8-8. KFR10: δ<sup>18</sup>O and <sup>3</sup>H values in groundwater samples from 1989 to 2010. The results from tritium analyses of samples taken before 1999 have been considered uncertain and are omitted in the diagram.*