

**International  
Progress Report**

**IPR-03-22**

# **Äspö Hard Rock Laboratory**

## **Prototype Repository**

### **Hydrogeological, Hydrochemical, Hydromechanical and Temperature Measurements in boreholes during the operation phase of the Prototype Repository Tunnel Section II**

Ingvar Rhén  
Torbjörn Forsmark  
Johan Magnusson  
Patrik Alm

SWECO VIAK AB

May 2003

**Svensk Kärnbränslehantering AB**

Swedish Nuclear Fuel  
and Waste Management Co  
Box 5864  
SE-102 40 Stockholm Sweden  
Tel +46 8 459 84 00  
Fax +46 8 661 57 19



**Äspö Hard Rock  
Laboratory**



Report no.	No.
IPR-03-22	F63K
Author	Date
Ingvar Rhén	2003-06-11
Torbjörn Forsmark	
Johan Magnusson	
Patrik Alm	
Checked by	Date
Christer Svemar	
Approved	Date
Christer Svemar	2003-07-03

# **Äspö Hard Rock Laboratory**

## **Prototype Repository**

### **Hydrogeological, Hydrochemical, Hydromechanical and Temperature Measurements in boreholes during the operation phase of the Prototype Repository Tunnel Section II**

Ingvar Rhén  
Torbjörn Forsmark  
Johan Magnusson  
Patrik Alm

SWECO VIAK AB

May 2003

*Keywords:* Äspö HRL, Prototype Repository, instrumentation of boreholes, hydrogeology, hydrochemistry, hydromechanical measurements, temperature, tunnel section II

This report concerns a study which was conducted for SKB. The conclusions and viewpoints presented in the report are those of the author(s) and do not necessarily coincide with those of the client.



# **PROTOTYPE REPOSITORY**

## **Deliverable D5**

### **Hydrogeological, Hydrochemical, Hydromechanical and Temperature Measurements in boreholes during the operation phase of the Prototype Repository Tunnel Section II**

Ingvar Rhén  
Torbjörn Forsmark  
Johan Magnusson  
Patrik Alm  
SWECO VIAK AB

May 2003

**EC Contract FIKW-2000-00055**

EC-5<sup>th</sup> EURATOM Framework programme 1998-2002  
Key Action: Nuclear Fission



# Abstract

The Prototype Repository is an international, EC-supported activity with the objective to investigate, on a full-scale, the integrated performance of engineered barriers and near-field rock of a simulated deep repository. This is done in crystalline rock regarding heat evolution, rock mechanics, water flow, water chemistry, gas evolution and microbial processes under natural and realistic conditions at approximately 450 m depth below the ground surface. The test site is a 65 m long TBM-bored drift from which six 1.75m diameter deposition holes extended downwards to about 8 m depth in accordance with the KBS-3 concept. The test site is divided in two parts; an inner 40 m long section (Section I) with 4 deposition holes and an outer section (Section II) with two deposition holes. Stiff and tight plugs will separate the sections and Section II from the rest of the Äspö Hard Rock Laboratory.

A large number of boreholes have been drilled to characterize the rock mass. These boreholes will be used for the long-time monitoring of the Prototype Repository. Packers, 1-5 in each borehole, are installed to facilitate monitoring of the water pressure and water chemistry in borehole sections. Temperature and deformation sensors are installed in some of the boreholes sections. Tubes and cables from the borehole sections are lead to a nearby G-tunnel, where the pressure, deformation and temperature are measured and the water is sampled. Hydraulic tests will also be performed from the G-tunnel by flowing of borehole sections (one by one) and measuring the pressure responses.

The report describes the instrumentation of the boreholes in Section II.





# Sammanfattning

Prototype Repository Project är ett internationellt, EC-stött projekt med syfte att i full skala undersöka den integrerade funktionen hos ingenjörbarriärer och närfältsberg i ett simulerat slutförvar i kristallint berg med hänsyn till värmeutveckling, bergmekanik, vattengenomströmning, vattenkemi, gasbildning och mikrobiologi under naturliga och realistiska förhållanden på ca 450m djup. Försöksplatsen är en 65m lång TBM-borrade tunnel från vilken sex vertikala deponeringshål med 1.75m diameter och 8m djup borraras i enlighet med KBS-3 konceptet. Testplatsen är delad i två delar; en inre 40m lång sektion (sektion I) med 4 deponeringshål och en yttre del (sektion II) med två deponeringshål. Stela och täta pluggar separerar sektionerna då respektive sektion II från resten av Äspölaboratoriet.

Ett stort antal borrhål har borraras för att karakterisera berget. Dessa borrhål kommer att användas för långtidsmonitoreringen av Prototypförvaret. Manschetter, 1-5 i varje borrhål, installeras för att möjliggöra instrumentering av vattentryck och vattenkemi i borrhålssektioner. Temperatur- och deformationsgivare leds till en parallellt liggande tunnel, G-tunneln, där tryck, deformationer och temperatur mäts och vattenprov tas. Hydrauliska tester görs också från G-tunneln genom att flöda borrhålssektioner (en i taget) och mäta tryckresponserna.

Denna rapport beskriver instrumenteringen av borrhål i sektion II.



# Executive Summary

The Prototype Repository is an international, EC-supported activity with the objective to investigate, on a full-scale, the integrated performance of engineered barriers and near-field rock of a simulated deep repository. This is done in crystalline rock regarding heat evolution, rock mechanics, water flow, water chemistry, gas evolution and microbial processes under natural and realistic conditions at approximately 450 m depth below the ground surface. The test site is a 65 m long TBM-bored drift from which six 1.75m diameter deposition holes extended downwards to about 8 m depth in accordance with the KBS-3 concept. The test site is divided in two parts; an inner 40 m long section (Section I) with 4 deposition holes and an outer section (Section II) with two deposition holes. Stiff and tight plugs will separate the sections and Section II from the rest of the Äspö Hard Rock Laboratory.

A large number of boreholes have been drilled to characterize the rock mass. These boreholes will be used for the long-time monitoring of the Prototype Repository. Packers, 1-5 in each borehole, are installed to facilitate monitoring of the water pressure and water chemistry in borehole sections. Temperature and deformation sensors are installed in some of the boreholes sections. Tubes and cables from the borehole sections are lead to a nearby G-tunnel, where the pressure, deformation and temperature are measured and the water is sampled. Hydraulic tests will also be performed from the G-tunnel by flowing of borehole sections (one by one) and measuring the pressure responses.

In this report the instrumentation of Section II is described. In tunnel Section II, 1m long inflatable packers are used in the long boreholes and mechanical packers of stainless steel are used in short boreholes. In three core holes drilled from tunnel G and the crossing between tunnels A and I/J, 1m long inflatable packers are also used.

Dilution measurements can be performed in the “circulation sections”. In ”flow sections” the borehole section can be flowed and the pressure is measured through a separate tube. PEEK tubes are connected to the “hydrochemistry sections” to get a diffusion tight system allowing studying the redox conditions. The number of different measurement sections in boreholes in tunnel section II is shown below:

	(No of)
• Pressure measurement sections:	52
• Circulation sections (two tubes):	10
• Flow sections (one or two tube-s):	3
• Hydrochemical sections:	0
• HM sections (same as circulation sections) with two deformation sensors	10

The number of different measurement sections in 2 long boreholes drilled from tunnel G and one from the crossing between tunnels A and I/J is shown below:

	(No of)
• Pressure measurement sections:	15
• Circulation sections (two tubes):	2
• Flow sections (one or two tube-s):	1
• Hydrochemical sections:	2
• HM sections	0

# Contents

<b>1</b>	<b>BACKGROUND</b>	<b>13</b>
1.1	Äspö Hard Rock Laboratory	13
1.2	Prototype Repository	14
1.2.1	General objectives	15
1.2.2	Objectives with this report	15
<b>2</b>	<b>EQUIPMENT AND INSTRUMENTATION OF BOREHOLES</b>	<b>17</b>
2.1	Overview of instrumentation	17
2.2	Instrumentation of Section II	19
2.2.1	Preparation work in the tunnel for the instrumentation	19
2.2.2	Borehole installation work and final instrumentation	20
<b>3</b>	<b>PRESSURE MEASUREMENTS</b>	<b>47</b>
3.1	Introduction	47
3.2	Measurements in the boreholes	47
3.3	Modelling	48
<b>4</b>	<b>DILUTION MEASUREMENTS</b>	<b>49</b>
4.1	Introduction	49
4.2	General principles	49
4.3	Measurements in the boreholes	51
4.4	Modelling	54
<b>5</b>	<b>HYDROCHEMICAL SAMPLING IN THE BOREHOLES</b>	<b>55</b>
5.1	Introduction	55
5.2	Sampling in borehole sections	56
5.3	Modelling	56
<b>6</b>	<b>FLOW SECTIONS</b>	<b>57</b>
6.1	Introduction	57
6.2	Sampling and hydraulic tests in borehole sections	57
6.3	Modelling	58
<b>7</b>	<b>TEMPERATURE MEASUREMENTS</b>	<b>59</b>
7.1	Introduction	59
7.2	Measurements in the boreholes	59
7.3	Modelling	59
<b>8</b>	<b>HYDRO MECHANICAL SECTIONS</b>	<b>61</b>
8.1	Introduction	61
8.2	Hydro Mechanical measurements in borehole sections	61
8.3	Modeling	63
	<b>References</b>	<b>65</b>
	<b>APPENDIX 1</b> Monitoring configuration of boreholes in tunnel section II	
	<b>APPENDIX 2</b> Position of measurement sections along boreholes in tunnel section II	
	<b>APPENDIX 3</b> Coordinates of boreholes	
	<b>APPENDIX 4</b> Denominations on cables and tubes from the Prototype Repository	

# List of Figures

Figure 1-1	Plan view over Äspö Hard Rock Laboratory.....	13
Figure 1-2	Overview of the Äspö tunnel. The Prototype Repository is located at 450 m depth below the ground surface. The vertical lines show the elevator and ventilation shafts from the ground surface.....	14
Figure 1-3	Schematic view of the layout of the Prototype Repository and deposition holes (not to scale). .....	16
Figure 2-1	View of the drilled core holes in the Prototype Repository. The length from the I-tunnel to the end of the TBM-tunnel is 90 m. The diameter of the TBM tunnel is 5m and the diameter of the deposition holes is 1.75 m. The depth of the deposition holes is 8.37 m in the centre and 8.15 m along the deposition hole wall. The diameter of the core holes is 76 mm except for the short core holes in the roof of the TBM tunnel that have a diameter of 56 mm. ....	19
Figure 2-2	Borehole enlargement with anchorage for borehole equipment.....	20
Figure 2-3	Hydro-mechanical equipment.....	24
Figure 2-4	Hydro mechanical equipment. Anchors with steel edge collar and steel plate (up). Fixed and springing steel pins locked by rod springing rod. When the lock cylinder is pressurised the springing sheet metal on the anchors holds back the steel pins towards the centre of the anchor.....	25
Figure 2-5	Hydro-mechanical equipment mounted on a centre rod between two packers....	27
Figure 2-6	The springing sheet metal on the anchors holds back the steel pins towards the centre of the anchor when the springing rod is pressurerised .....	28
Figure 2-7	To the left: Steel edge collar. To the right: solid steel plate. The springing steel pin and solid plate is expected to glide along the rock wall while the solid steel pin and the steel edge collar is the position of the anchor that is firmly connected to the rock wall.....	28
Figure 2-8	Air- and water-tight cable coupling from strain gauge. The sealing compound was PDM EMC-697 70 shore A.....	29
Figure 2-9	First version of hydro mechanical anchors with strain gauge. Original from Geokon with copper bladders. Copper bladders are inflated by pressure to fix the anchors to the rock wall.....	29
Figure 2-10	Second version of hydro mechanical anchors with strain gauge. Anchors modified with steel pins that later were change to a steel edge collar and a solid steel plate. Otherwise equal to version 3 that is shown on previous figures and in the text. ....	30
Figure 2-11	Installing HM equipment.....	31
Figure 2-12	Installing HM equipment. Tubes and connections between upper anchor and packer. ....	32
Figure 2-13	During installation of the equipment the positioning and lock cylinders were pressurerised. ....	33
Figure 2-14	. The cables from the HM sensors was connected to cables from the G-tunnel by soldering and then a steel tube was put over the soldering and the sealing compound (PDM EMC-697 70 shore A) was pored into the steel cylinder. ....	33

Figure 2-15	Borehole enlargement in the tunnel floor with anchorage for borehole equipment. ....	34
Figure 2-16	Tunnel-floor borehole covered with steel plate. ....	35
Figure 2-17	Tunnel-wall borehole. ....	35
Figure 2-18	Mechanical packer. ....	36
Figure 2-19	Mechanical packer. ....	37
Figure 2-20	Mounted mechanical packer. (Borehole in figure is located in Section I). ....	38
Figure 2-21	Boreholes with monitoring sections in Prototype Repository Section II. ....	39
Figure 2-22	Boreholes with monitoring sections in Prototype Repository Section II. ....	39
Figure 2-23	Boreholes with monitoring sections in Prototype Repository Section II. ....	40
Figure 2-24	Boreholes with monitoring sections in Prototype Repository Section II. ....	40
Figure 2-25	Tubes and cables being installed in a lead-through hole. ....	41
Figure 2-26	Stand for cables, tubes and lid for the lead-through holes. ....	42
Figure 2-27	Lead-through holes with lid fixed. ....	43
Figure 2-28	The connection of cables and tubes from the boreholes to the lid was made successively during the backfilling operation. Cables and tubes were fixed to the surface of the backfilling before commencing a new layer of backfill material. ....	44
Figure 2-29	In the G-tunnel, tubes from the borehole sections are connected to pressure transducers (one per bh-section at the panel for transducers), circulation and flow tubes to separate valves and the cables from the deformation sensors to electronic devices. The yellow labels are the ID-labels according to Appendix 4. ....	45
Figure 2-30	The equipment for pressurizing the inflatable packers is in the G-tunnel. A pressure vessel filled with water and connected to several packers. The packers are expanded by pressurizing the water-filled pressure vessel (light above) with nitrogen gas (Nitrogen tube, black above). ....	46
Figure 2-31	Boreholes KG0021A01 and KG0048A01 are equipped with a casing that is used for the anchoring the packers. ....	46
Figure 3-1	All pressure transducers are connected to the HMS system. In the G-tunnel there is a computer in the HMS system where logging frequencies easily can be changed. ....	48
Figure 4-1	Schematic description of dilution measurements. To the left: Flow in fractured crystalline rock. To the right: Ground water flow in a porous medium. L: length of test section. d: diameter of the borehole section. $D_e^m$ : Effective diffusion coefficient of the rock matrix. $D_e^f$ : Effective diffusion coefficient in the fractures. ....	50
Figure 4-2	Schematic description of a dilution curve. A: Homogenisation in the borehole section. B: Curve used for evaluation of $q_{bh}$ . ....	51
Figure 4-3	The time interval, for 0.1, 0.5 and 0.9 of the initial tracer quantity takes to be carried through borehole out of the formation, for different flow velocities in a borehole section with diameter 76 mm. V: total volume of borehole section. $V_d$ : Volume of dummy and other space filling parts in the borehole section. ....	53
Figure 8-1	Schematic figure of the measurement equipment and measurement sections. ....	62

## List of Tables

Table 2-1	Instrumentation configuration. “Tubes/pipes”: pipes between the packers. ....	21
Table 2-2	Boreholes instrumented with mechanical packers (“Inclination”: inclination of the borehole.).....	36
Table 4-1	Estimated mean flow porosity and effective diffusion coefficient as function of transmissivity of a borehole section with length 1-3 m. ....	52
Table 4-2	Estimated filtration velocity (q) with assumed hydraulic conductivity (K) and hydraulic gradient (i).....	52
Table 6-1	The table presents the results from the calculations. Q stands for flow rate, Re stands for Reynolds’s number, $T_{\text{water}}$ stands for the water temperature in the rock and $D_{\text{tube}}$ stands for the inner tube diameter.....	58



# 1 Background

## 1.1 Äspö Hard Rock Laboratory

To prepare for the location of a site and licensing of a spent fuel repository SKB has constructed an underground research laboratory.

In the autumn of 1990, SKB began the construction of Äspö Hard Rock Laboratory (Äspö HRL), see Figure 1-1, near Oskarshamn in the southeastern part of Sweden. A 3.6 km long tunnel was excavated in crystalline rock down to a depth of approximately 460 m, see Figure 1-2.

The laboratory was completed in 1995 and research concerning the disposal of nuclear waste in crystalline rock has since then been carried on.

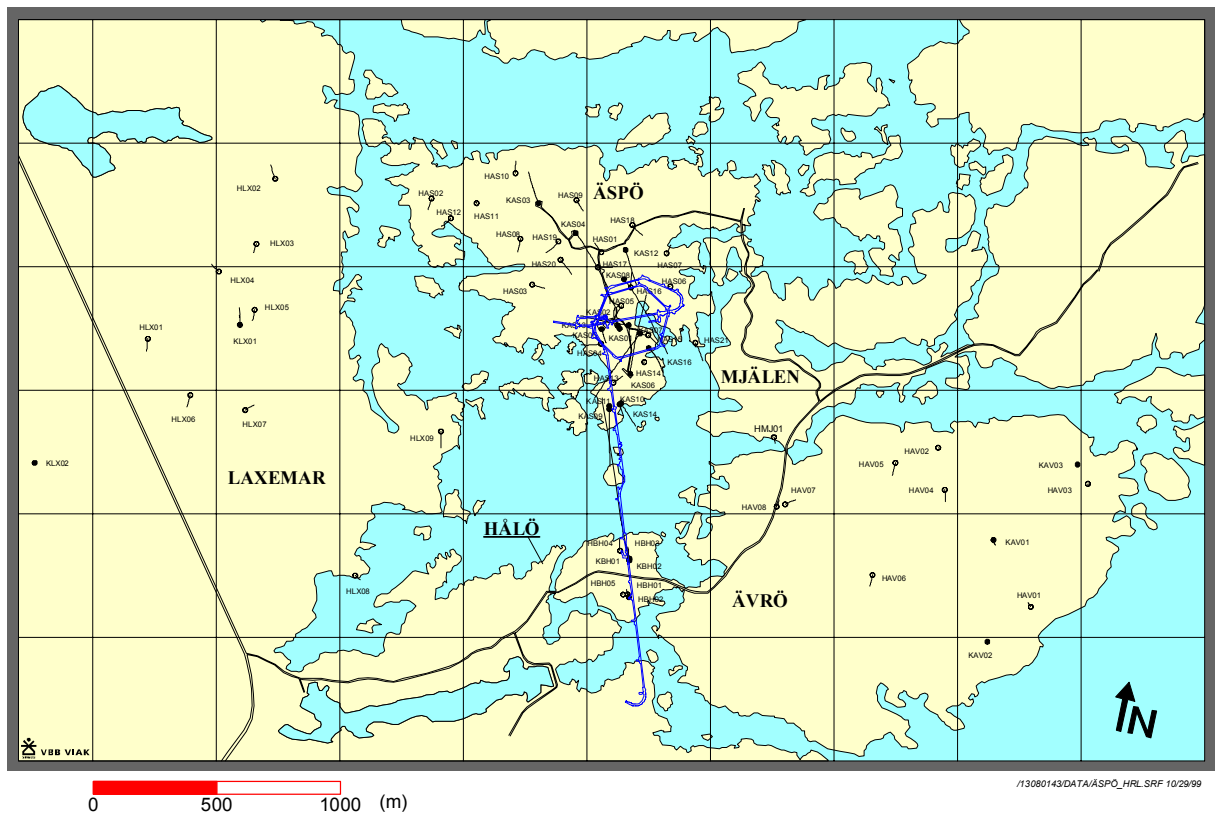
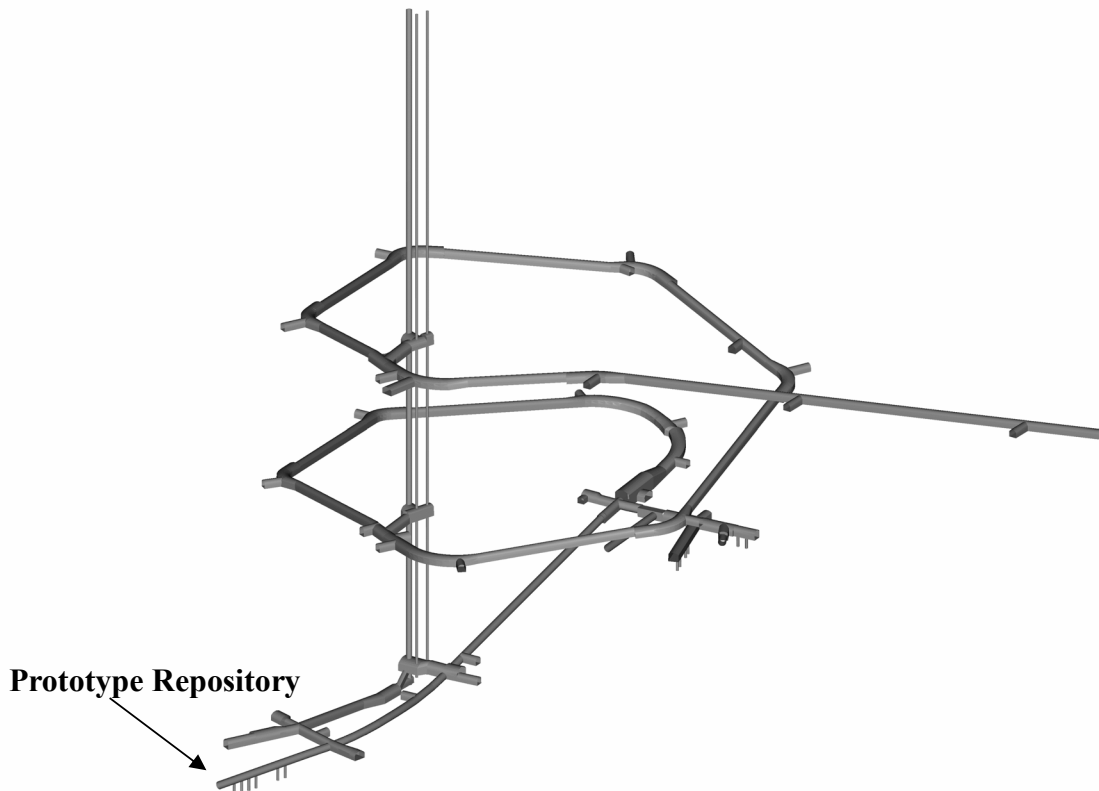


Figure 1-1 Plan view over Äspö Hard Rock Laboratory.



*Figure 1-2 Overview of the Äspö tunnel. The Prototype Repository is located at 450 m depth below the ground surface. The vertical lines show the elevator and ventilation shafts from the ground surface.*

## 1.2 Prototype Repository

The Äspö Hard Rock Laboratory is an essential part of the research, development, and demonstration work performed by SKB in preparation for construction and operation of the deep repository for spent fuel. Within the scope of the SKB program for RD&D 1995, SKB has decided to carry out a project with the designation “Prototype Repository Test“. The aim of the project is to test important components in the SKB deep repository system on a full scale and in a realistic environment.

The Prototype Repository Test is focused on testing and demonstrating the function of the SKB deep repository system. Activities aimed at contributing to development and testing of the practical, engineering measures required to rationally perform the steps of a deposition sequence are also included. However, efforts in this direction are limited, since these matters are addressed in the Demonstration of Repository Technology project and to some extent in the Backfill and Plug Test.

Project plan and project description of the Prototype Repository are described in Svemar and Pusch (2000) and Persson and Broman (2000).

### **1.2.1 General objectives**

The Prototype Repository should simulate as many aspects as possible of a real repository, for example regarding geometry, materials, and rock environment. The Prototype Repository is a demonstration of the integrated function of the repository components. Results will be compared with models and assumptions to their validity.

The major objectives for the Prototype Repository are:

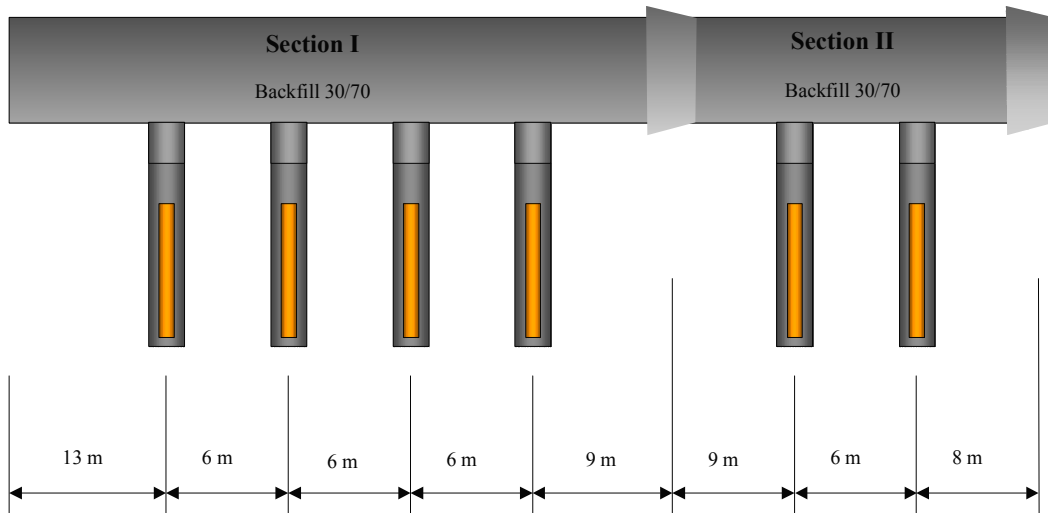
- To simulate part of future KBS-3 deep repository to the extent possible regarding geometry, design, materials, construction and rock environment except that electric heaters simulate radioactive waste.
- To test and demonstrate the integrated function of the repository components under realistic conditions on a full scale.
- To develop, test and demonstrate appropriate engineering standards and quality assurance methods.
- To accomplish confidence building as the capability of modelling EBS performance.

The objectives for the characterisation program are:

- To provide a basis for determination of location of the deposition holes.
- To provide data on boundary and rock conditions for enabling the interpretation of the experimental data.

### **1.2.2 Objectives with this report**

The instrumentation of the boreholes is done mainly in two stages. Section I was instrumented during the spring 2001 and Section II was instrumented during Autumn 2002 to Spring 2003, see Figure 1-3. This report describes the instrumentation of Section II. In Chapter 2, the instrumentation in the boreholes is described and in Chapter 3-7 the purpose, a concept etc. of the measurements are briefly outlined.



**Figure 1-3** Schematic view of the layout of the Prototype Repository and deposition holes (not to scale).

## 2 Equipment and instrumentation of boreholes

### 2.1 Overview of instrumentation

During the characterisation of the rock around the Prototype Repository a large number of core boreholes have been drilled, see Figure 2-1. Most of these boreholes will be equipped with packer systems to allow for:

- Pressure measurements
- Water sampling
- Dilution measurements
- Interference tests
- Hydro mechanical measurements (HM) and tests

In some of the boreholes temperature measurements will be made. Below is an overview of the instrumentation given:

Section I (as made)	(No of)
• Bentonite packers (1-2 m long, 2-5 packers in each 8-50 m borehole):	49
• Mechanical packers (one in each 2 m borehole, stainless):	16
• Pressure measurement sections:	65
• Circulation sections (two tubes):	5
• Flow sections (one-two tube-s):	7
• Hydrochemical sections:	6
• HM sections:	0

Boreholes around the outer plug are planned to be drilled and instrumented after the instrumentation of section II.

Section II	(No of)
• Inflatable packers (1m long, 1-5 in each 3-30 m borehole):	46
• Mechanical packers (one in each 2 m borehole, stainless):	6
• Pressure measurement sections (including measurements around plug): 52	
• Circulation sections:	10
• Flow (one tube):	3
• Hydrochemical sections:	0
• HM sections (same as circulation sections):	10

G-tunnel+KA3510A01

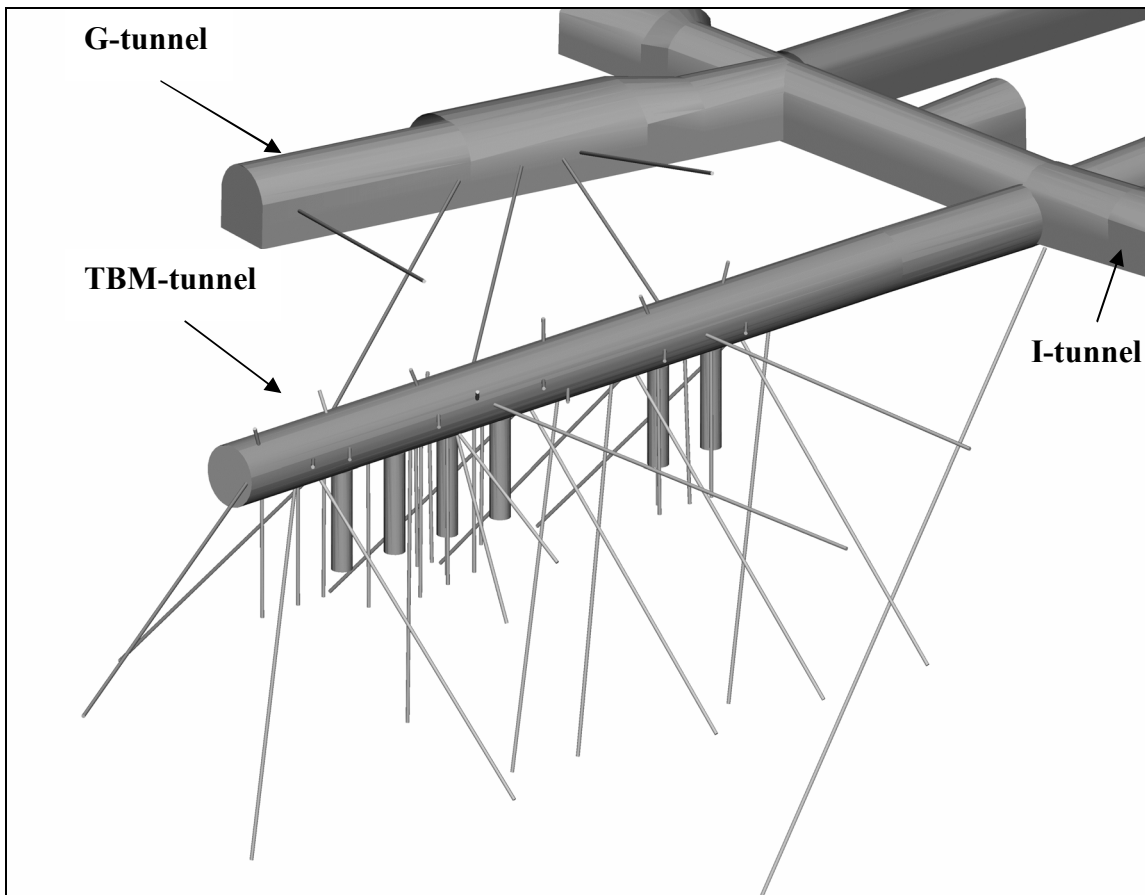
• Inflatable packers (1m long, 5 in each 49-150 m borehole):	15
• Pressure measurements sections (5 in each borehole):	15
• Circulation sections (holes from G-tunnel):	2
• Flow (one tube, KA3510A01):	1
• Hydrochemical sections (holes from G-tunnel):	2
• HM sections (reference in G-tunnel, the north tunnel wall):	1

Outer plug (as planned) (No of)

• Inflatable (1 m long, 3 in each 15 m borehole):	12
• Pressure measurement sections (including measurements around plug):	12
• Flow (one tube):	0

The tube types between and from packers will be according to below:

• Pressure:	Polyamide
• Groundwater flow (Dilution measurements):	
○ Circulation (two pipes):	Polyamide
○ Pressure:	Polyamide
• Hydrochemical	
○ Flow:	PEEK
○ Pressure:	Polyamide

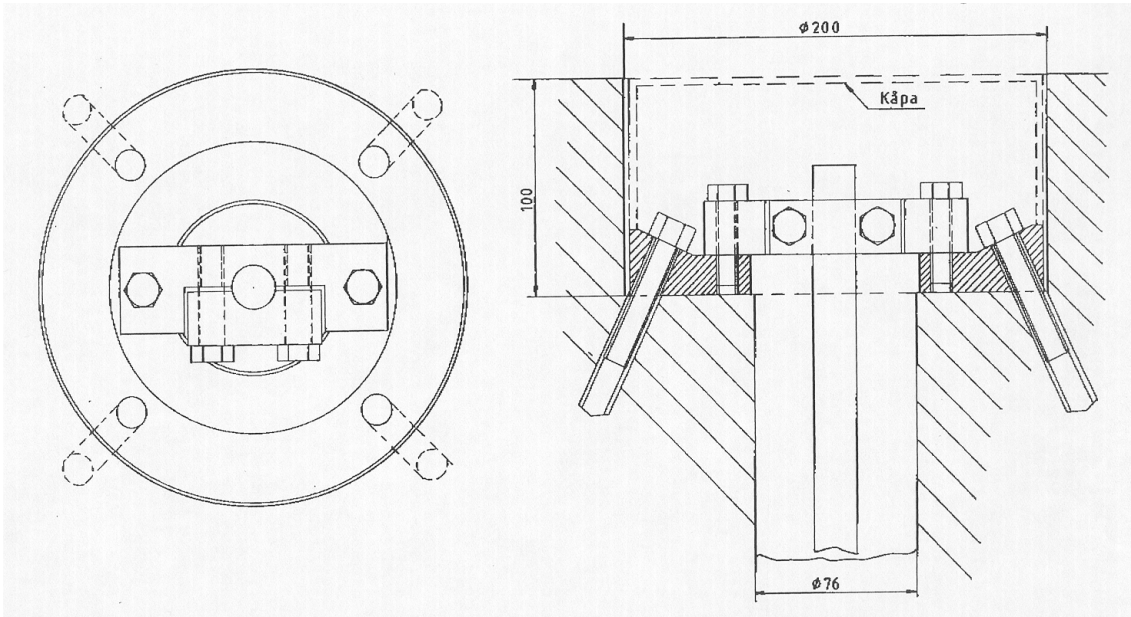


**Figure 2-1** View of the drilled core holes in the Prototype Repository. The length from the I-tunnel to the end of the TBM-tunnel is 90 m. The diameter of the TBM tunnel is 5m and the diameter of the deposition holes is 1.75 m. The depth of the deposition holes is 8.37 m in the centre and 8.15 m along the deposition hole wall. The diameter of the core holes is 76 mm except for the short core holes in the roof of the TBM tunnel that have a diameter of 56 mm.

## 2.2 Instrumentation of Section II

### 2.2.1 Preparation work in the tunnel for the instrumentation

Before instrumentation of boreholes begun, the uppermost 100 mm of boreholes in the tunnel floor was enlarged to a diameter of 200 mm to house the anchorage of the equipment, see Figure 2-2 and 2-15. To get a smooth bend on the tubes and pipes coming out of the borehole towards the tunnel floor a slot was cut from the side of the enlargement (Figure 2-15). This slot also room the necessary couplings outside the borehole and the casting box for the signal cable from the deformation transmitters. A flange was mounted into the enlargement onto which the equipment was anchored (Figures 2-2 and 2-15). A cover plate was mounted at each borehole to protect the locking device and tube endings (Figure 2-16). Boreholes on the walls were not enlarged to house the anchorage for the borehole equipment. The anchorage was mounted directly on the wall covered by a steel plate, see Figure 2-17.



**Figure 2-2** Borehole enlargement with anchorage for borehole equipment.

## 2.2.2 Borehole installation work and final instrumentation

### *Instrumentation with hydraulic packers*

Eighteen boreholes were equipped with hydraulically expanded packers of one meters length to seal off at most five sections in one borehole. In ten of these boreholes one section also were instrumented with hydro-mechanical equipment adapted to measure small deformations in the solid rock and over selected fractures. Another borehole in the G-tunnel was instrumented with HM equipment as a reference. The borehole was drilled in the north tunnel wall and is not expected to be influenced by the stress changes around the Prototype tunnel. In the Table 2-1 extension of borehole sections, type of measurements and number and type of necessary tubes and pipes from each packer are listed. The installation drawings may be found in Appendix 1.

### *Inflatable packers*

The packers are of the type PU53 or PU72. All packers have an inflation length of one meter and the minimum and maximum packer expansion pressure is 6.5 bar and 65 bar respectively. They are expanded by means of water, pressurised by nitrogen gas in a pressure vessel (Figure 2-30). A regulator controls the magnitude of the inflation pressure. The stainless steel pressure vessel is connected to the packers by a high-pressure 6/4-mm polyamide tube, type Tecalan. A check valve unit with a manometer is mounted on the packer inflation line. In order to avoid accidental deflation the check valve unit also includes a stop valve.



**Table 2-1 Instrumentation configuration. “Tubes/pipes”: pipes between the packers.**

Borehole:sec	Sec. length (m)	Type of section	Tubes/pipes (no:diameter:type)
KA3539G:1	18.6 – 30	P	1:4/2:PA, 1:6/4:PA
KA3539G:2	15.85 – 17.6	P, HM, C	2:4/2:PA, 3:6/4:PA, 3:4/2:ST, 2:8/6:ST
KA3539G:3	10 – 14.85	P, F	3:4/2:PA, 4:6/4:PA, 3:4/2:ST, 2:8/6:ST
KA3539G:4	4 – 9	P	4:4/2:PA, 4:6/4:PA, 3:4/2:ST, 2:8/6:ST
KA3542G01:1	27 – 30	P	1:4/2:PA, 1:6/4:PA
KA3542G01:2	21.3 – 26	P	2:4/2:PA, 1:6/4:PA
KA3542G01:3	18.6 – 20.3	P, HM,C	3:4/2:PA, 3:6/4:PA, 3:4/2:ST, 2:8/6:ST
KA3542G01:4	10.5 – 17.6	P	4:4/2:PA, 3:6/4:PA, 3:4/2:ST, 2:8/6:ST
KA3542G01:5	3.5 – 9.5	P	5:4/2:PA, 3:6/4:PA, 3:4/2:ST, 2:8/6:ST
KA3542G02:1	28.2 – 30.01	P	1:4/2:PA, 1:6/4:PA
KA3542G02:2	25.6 – 27.2	P, HM, C	2:4/2:PA, 3:6/4:PA, 3:4/2:ST, 2:8/6:ST
KA3542G02:3	21.5 – 24.6	P	3:4/2:PA, 3:6/4:PA, 3:4/2:ST, 2:8/6:ST
KA3542G02:4	9 – 20.5	P	4:4/2:PA, 3:6/4:PA, 3:4/2:ST, 2:8/6:ST
KA3542G02:5	2 – 8	P, F	5:4/2:PA, 4:6/4:PA, 3:4/2:ST, 2:8/6:ST
KA3544G01:1	11.65 – 12	P	1:4/2:ST, 1:6/4:ST
KA3544G01:2	8.9 – 10.65	P, HM, C	5:4/2:ST, 3:6/4:ST, 2:8/6:ST
KA3544G01:3	3.5 – 7.9	P	6:4/2:ST, 3:6/4:ST, 2:8/6:ST
KA3546G01:1	9.3 – 12	P	1:4/2:ST, 1:6/4:ST
KA3546G01:2	6.75 – 8.3	P, HM, C	5:4/2:ST, 3:6/4:ST, 2:8/6:ST
KA3546G01:3	1.5 – 5.75	P	6:4/2:ST, 3:6/4:ST, 2:8/6:ST
KA3548A01:1	21.5 – 30	P	1:4/2:PA, 1:6/4:PA
KA3548A01:2	11.75 – 20.5	P, F	2:4/2:PA, 2:6/4:PA
KA3548A01:3	8.8 – 10.75	P, HM, C	3:4/2:PA, 4:6/4:PA, 3:4/2:ST, 2:8/6:ST
KA3548A01:4	3 – 7.8	P	4:4/2:PA, 4:6/4:PA, 3:4/2:ST, 2:8/6:ST
KA3548G01:1	6-12	P	2:6/4:PA
KA3548G01:2	2-5	P	3:6/4:PA
KA3550G01:1	8.3 – 12.03	P	1:4/2:ST, 1:6/4:ST
KA3550G01:2	5.2 – 7.3	P, HM, C	5:4/2:ST, 3:6/4:ST, 2:8/6:ST
KA3550G01:3	1.8 – 4.2	P	6:4/2:ST, 3:6/4:ST, 2:8/6:ST
KA3550G05:1	1.5 – 3	P	1:4/2:ST, 1:6/4:ST
KA3551G05:1	1.5 – 3.1	P	1:4/2:ST, 1:6/4:ST
KA3552G01:1	7.05 – 12	P	1:4/2:ST, 1:6/4:ST
KA3552G01:2	4.35 – 6.05	P, HM, C	5:4/2:ST, 3:6/4:ST, 2:8/6:ST
KA3552G01:3	1.5 – 3.35	P	6:4/2:ST, 3:6/4:ST, 2:8/6:ST
KA3554G01:1	25.15 – 30.01	P	1:4/2:PA, 1:6/4:PA
KA3554G01:2	22.6 – 24.15	P, HM, C	2:4/2:PA, 3:6/4:PA, 3:4/2:ST, 2:8/6:ST
KA3554G01:3	14 – 21.6	P	3:4/2:PA, 3:6/4:PA, 3:4/2:ST, 2:8/6:ST
KA3554G01:4	5 – 13	P	4:4/2:PA, 3:6/4:PA, 3:4/2:ST, 2:8/6:ST
KA3554G01:5	1.5 – 4	P	5:4/2:PA, 3:6/4:PA, 3:4/2:ST, 2:8/6:ST
KA3554G02:1	22 – 30.01	P	1:4/2:PA, 1:6/4:PA
KA3554G02:2	15.9 – 21	P	2:4/2:PA, 1:6/4:PA
KA3554G02:3	13.2 – 14.9	P	3:4/2:PA, 1:6/4:PA
KA3554G02:4	10.5 – 12.2	P, HM, C	4:4/2:PA, 3:6/4:PA, 3:4/2:ST, 2:8/6:ST
KA3554G02:5	1.5 – 9.5	P	5:4/2:PA, 3:6/4:PA, 3:4/2:ST, 2:8/6:ST
KA3557G:1	15 – 30.04	P	1:4/2:PA, 1:6/4:PA
KA3557G:2	1.5 – 14	P	2:4/2:PA, 1:6/4:PA
KA3510A:1	125 – 150	P	2:6/4:PA
KA3510A:2	110 – 124	P, F	4:6/4:PA
KA3510A:3	75 – 109	P	5:6/4:PA
KA3510A:4	51 – 74	P	6:6/4:PA

Borehole:sec	Sec. length (m)	Type of section	Tubes/pipes (no:diameter:type)
KA3510A:5	4.5 – 50	P	7:6/4:PA
KG0010B01:1	2.8 – 4.35	HM	3:4/2:ST, 2:8/6:ST
KG0021A01:1	42.5 – 48.82	P, HC	2:6/4:PA, 1:1/8"/2:PE
KG0021A01:2	37 – 41.5	P	3:6/4:PA, 1:1/8"/2:PE
KG0021A01:3	35 – 36	P, C	6:6/4:PA, 1:1/8"/2:PE
KG0021A01:4	19 – 34	P	7:6/4:PA, 1:1/8"/2:PE
KG0021A01:5	5 – 18	P	9:6/4:PA, 1:1/8"/2:PE
KG0048A01:1	49 – 54.69	P, HC	2:6/4:PA, 1:1/8"/2:PE
KG0048A01:2	34.8 – 48	P	3:6/4:PA, 1:1/8"/2:PE
KG0048A01:3	32.8 – 33.8	P, C	6:6/4:PA, 1:1/8"/2:PE
KG0048A01:4	13 – 31.8	P	7:6/4:PA, 1:1/8"/2:PE
KG0048A01:5	5 – 12	P	9:6/4:PA, 1:1/8"/2:PE

Type of section:

P Pressure measurement  
 C Circulation possible  
 HM Hydro-mechanical measurements  
 F Flow  
 HC Hydro chemical sampling

Materials:

PA Polyamide tube  
 ST Stainless steel pipe

### *Tubes, pipes and cables*

Tubes and cables from the A-tunnel to the G-tunnel through the Lead-through holes were installed before the boreholes were instrumented, see Figures 2-25 to 2-27.

The following tubes and pipes was used for different purposes:

Purpose	Dimension	Material
Transmission of the groundwater pressure from the isolated borehole sections to the borehole collar	4/2-mm	Polyamide or stainless steel
Transmission of the groundwater pressure from the isolated borehole sections to the borehole collar in borehole KA3557G (2 sections)	6/4-mm	Polyamide
Circulation tubes in the sections containing the hydro-mechanical equipment	6/4-mm	Polyamide or stainless steel
To position and fasten the anchors in the hydro-mechanical installations	4/2-mm	Stainless steel
To hose the cables from the movement transmitters	8/6-mm	Stainless steel
Extra flow lines	6/4-mm	Polyamide
Tubes from borehole collar to the G-tunnel	6/4-mm	Polyamide

Depending on expected temperature increase near the deposition holes six of the boreholes was equipped only with stainless steel pipes instead of polyamide.

Stainless steel couplings (Swagelock) are used to connect all types of tubes and pipes.

The section with the equipment for the HM measurements was connected to a pair of inflatable packers in the laboratory to get a better control of the instrumentation, see Figures 2-3 and 2-5. In the tunnel the rests of the equipment above and below the HM section was built in place, see Figure 2-11.

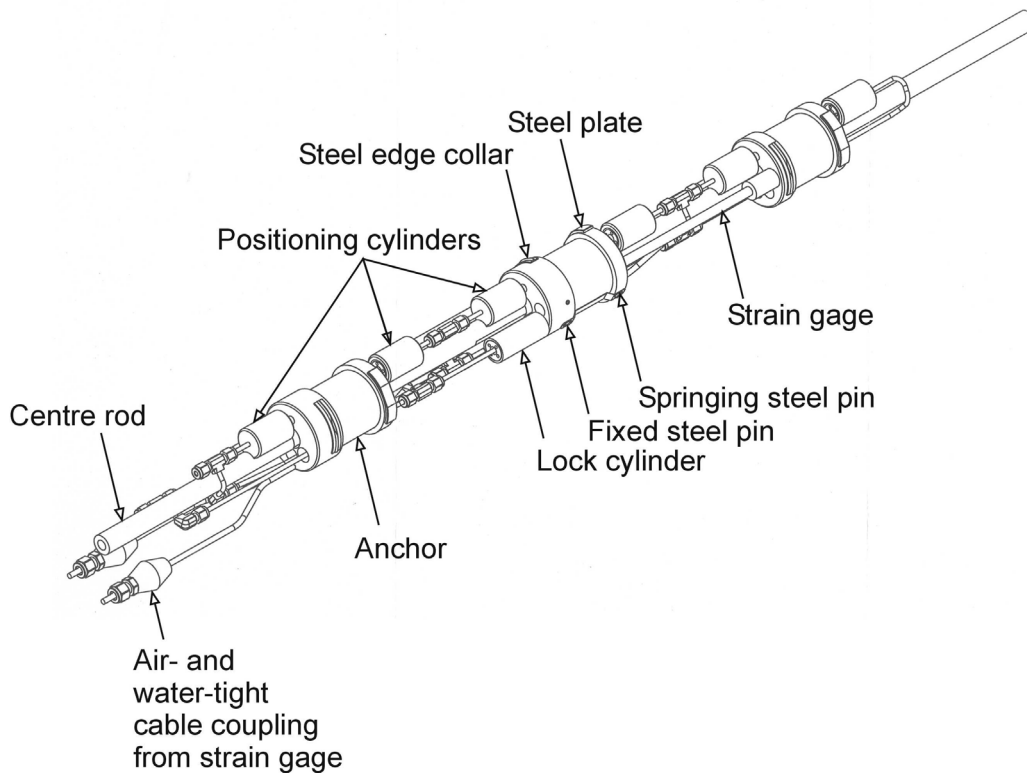
All tubes and pipes were temporarily plugged at the borehole collar until the backfill phase when they were connected to tubes leading to the G-tunnel via the lead-trough boreholes. The electrical cables from the deformation transmitters end up in a special “box” prepared for casting after connection during the backfill phase (Figure 2-14).

All tubes, pipes and cables coming out of the boreholes were labelled with a plastic tab with a unique identification number given by the cross-reference list in Appendix 4. This is needed later on, during the backfill phase, when connection to the cable/tube bundles leading to the G-tunnel via the lead-trough boreholes takes place. All tubes and pipes inside the boreholes were attached to the stainless steel rods by plastic tape.

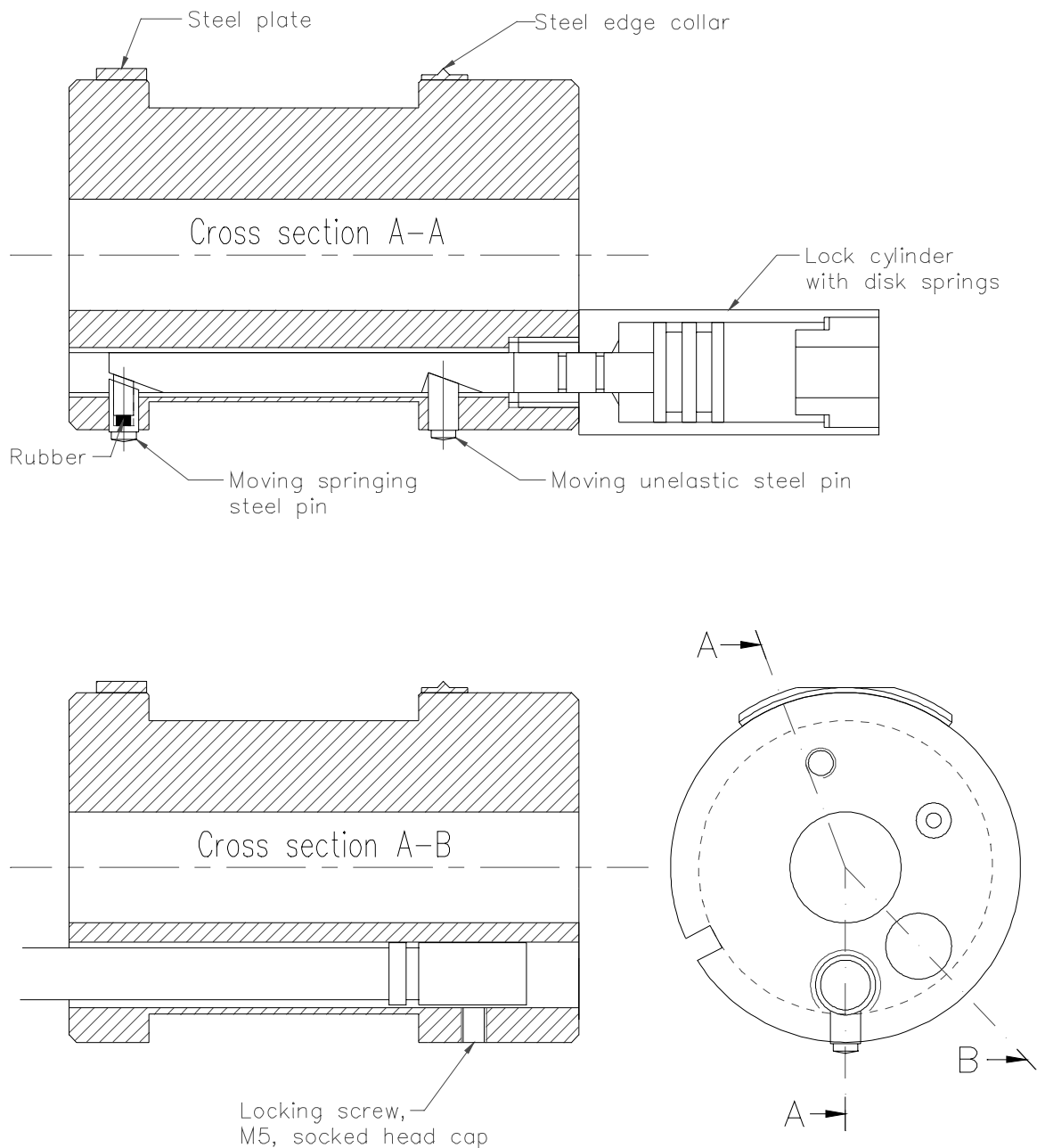
In the G-tunnel, section tubes from the cable/tube bundles were connected to pressure transducers (one per section at a transducer panel), circulation tubes to valves and the cables from the deformation sensors to data loggers. When the pressure lines were complete they were de-aired before connection to the transducers. If the flow from a section was very small it was necessary to fill the system with water from the outside. In such a case formation water from a nearby borehole/section was used. The panels for pressure transducers and valves are shown in Figure 2-29.

#### *Hydro-mechanical equipment*

One task is to examine hydro-mechanical effects connected to the warming, emanating from the canisters with heating elements that are placed in the deposition holes no 5 and 6. Therefore, deformation measurements will be performed in ten borehole sections around the Prototype tunnel. In these sections also pressure will be measured and circulation of water will be possible. In one borehole section in the G-tunnel a reference for deformation measurements is also installed. The hydro-mechanical equipment is built up of three anchors with two deformation sensors. The anchors are made of stainless steel. In pairs the anchors will measure the movement both in intact rock and over a fracture (or a few fractures) + intact rock. Figure 2-3 shows one pair of anchors with deformation sensors.



*Figure 2-3 Hydro-mechanical equipment*



**Figure 2-4** *Hydro mechanical equipment. Anchors with steel edge collar and steel plate (up). Fixed and springing steel pins locked by rod springing rod. When the lock cylinder is pressurised the springing sheet metal on the anchors holds back the steel pins towards the centre of the anchor.*

Geosigma AB has modified the anchors for SKB from a commercial available set of anchors and sensors from Geokon. In Figure 2-9 the original HM equipment is shown and in Figure 2-10 the second version. The third version, which has been installed, is shown in Figures 2-3 to 2-7

Special designed packers have lead-through to room the signal cables from the deformation sensors out from the borehole. To be able to position and fasten the anchors to the borehole wall another two pipes delivering pressure from outside is connected to positioning- and lock-cylinders in these sections.

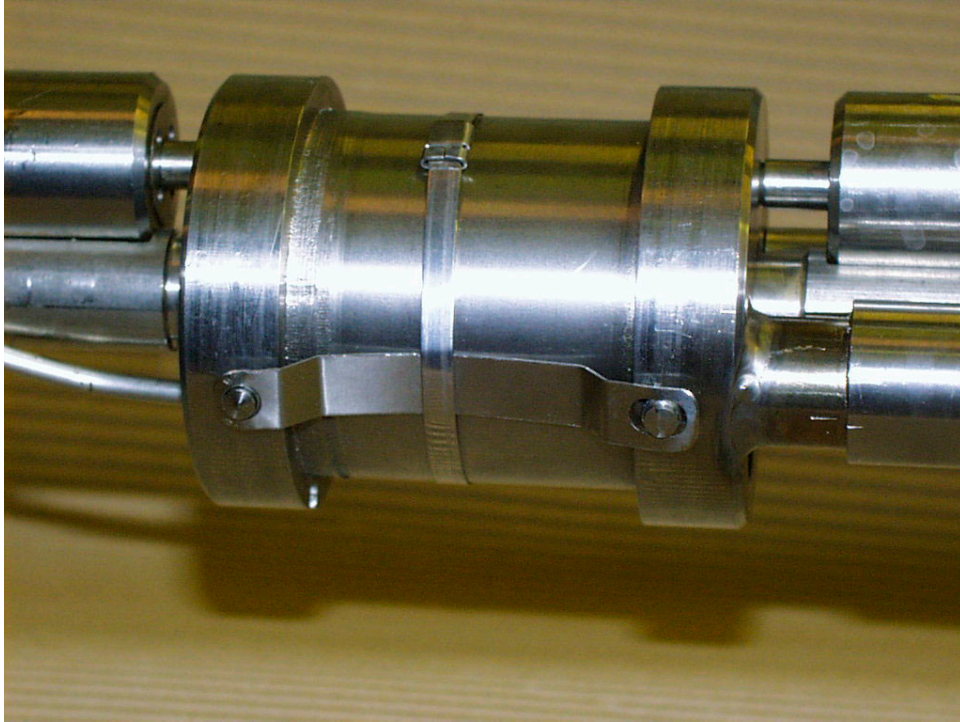
The installation was as follows:

1. HM equipment was in laboratory mounted on a centre rod between two packers. The locking screw for the strain gage was fastened and the position of the anchor was adjusted to give the reading required. Positioning cylinders were attached to the centre rod for locking position of the anchors when pressurised.
2. During installation of the equipment the positioning and lock cylinders were pressurised with about 85 bar. The springing sheet metal on the anchors holds back the steel pins towards the centre of the anchor. The pressurised position cylinders keep the anchors firmly to the centre rod while installing the equipment.
3. The inflatable packers are expanded and tested to assure proper function. Tubes from the measurement section are open.
4. The pressure is released to the lock cylinders connected to springing rod. The springing rod presses the solid and springing steel pins against the rock wall and locks the anchor against the rock wall. (The springing steel pin and solid steel plate is expected to glide along the rock wall while the solid steel pin and the steel edge collar is the position of the anchor that is firmly connected to the rock wall. According to tests in a steel tube, the tensile force is 550-750 N for the section with the solid steel pin compared 150-200 N for the section with the springing steel pin.)
5. The pressure is released to the positioning cylinders releasing the anchors from the centre rod.
6. The inflatable packers are deflated. (The packers are inflated during the backfilling of the tunnel.)

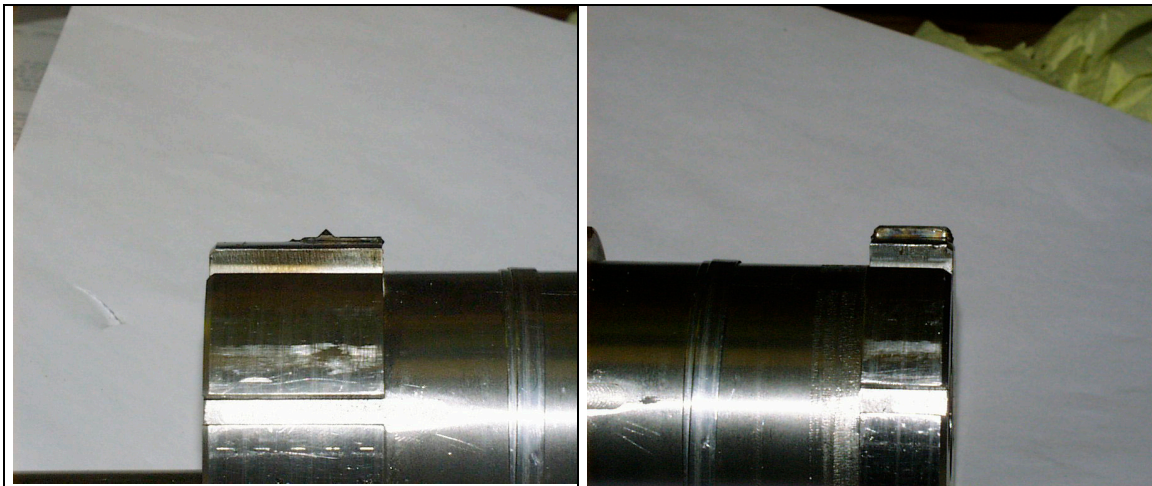
The resolution of the deformation sensors are  $< 2 \mu\text{m}$  and the measurement technique is vibrating wire.



*Figure 2-5 Hydro-mechanical equipment mounted on a centre rod between two packers.*



*Figure 2-6 The springing sheet metal on the anchors holds back the steel pins towards the centre of the anchor when the springing rod is pressurised*

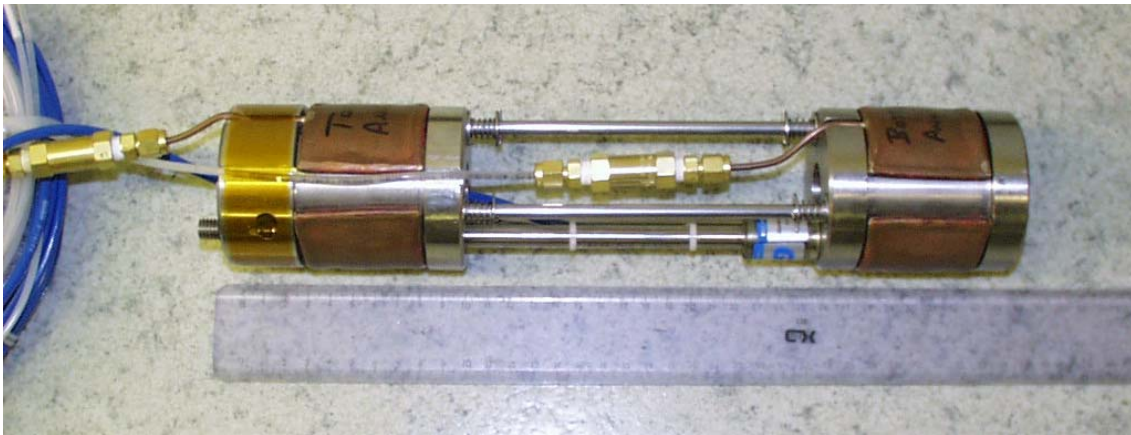


*Figure 2-7 To the left: Steel edge collar. To the right: solid steel plate. The springing steel pin and solid plate is expected to glide along the rock wall while the solid steel pin and the steel edge collar is the position of the anchor that is firmly connected to the rock wall*

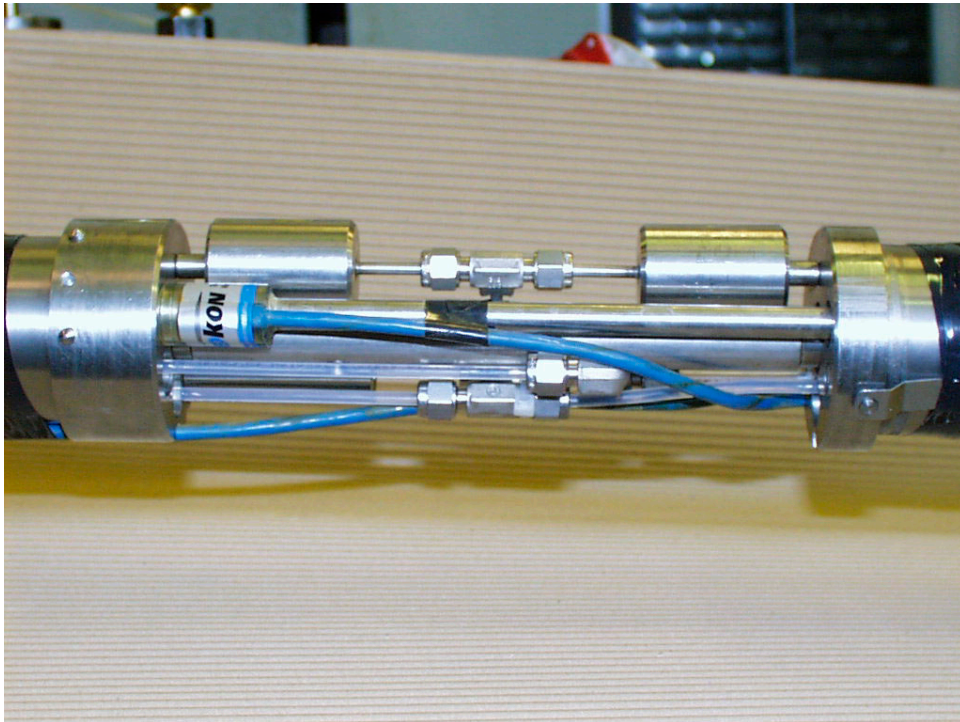




*Figure 2-8 Air- and water-tight cable coupling from strain gauge. The sealing compound was PDM EMC-697 70 shore A.*



*Figure 2-9 First version of hydro mechanical anchors with strain gauge. Original from Geokon with copper bladders. Copper bladders are inflated by pressure to fix the anchors to the rock wall.*



*Figure 2-10 Second version of hydro mechanical anchors with strain gauge. Anchors modified with steel pins that later were change to a steel edge collar and a solid steel plate. Otherwise equal to version 3 that is shown on previous figures and in the text.*

#### *Inserting and locking the equipment*

The equipment is inserted into the borehole with Ø 20-mm massive stainless steel rods. A special designed manual hoisting-rig is used if needed. When the packers are at their correct position the equipment will be attached to a locking device mounted on the tunnel wall at the borehole collar. Before insertion the equipment is cleaned with a cleaner delivering hot steam (100 °C) at high pressure.



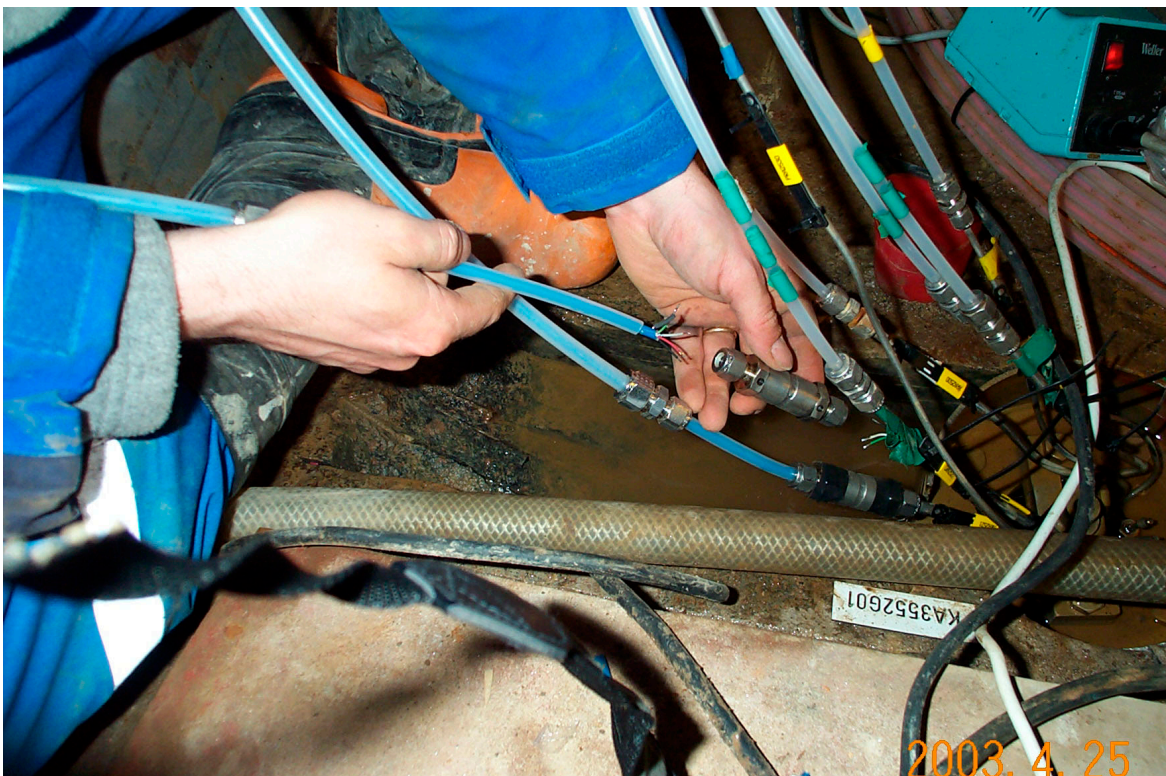
*Figure 2-11 Installing HM equipment.*



*Figure 2-12 Installing HM equipment. Tubes and connections between upper anchor and packer.*



*Figure 2-13 During installation of the equipment the positioning and lock cylinders were pressurerised.*



*Figure 2-14. The cables from the HM sensors was connected to cables from the G-tunnel by soldering and then a steel tube was put over the soldering and the sealing compound (PDM EMC-697 70 shore A) was pored into the steel cylinder.*



*Figure 2-15 Borehole enlargement in the tunnel floor with anchorage for borehole equipment.*

After finalization of instrumentation the borehole is covered with a steel plate in the tunnel floor or a steel box on the tunnel wall, see Figures 2-15 and 2-16



*Figure 2-16 Tunnel-floor borehole covered with steel plate.*



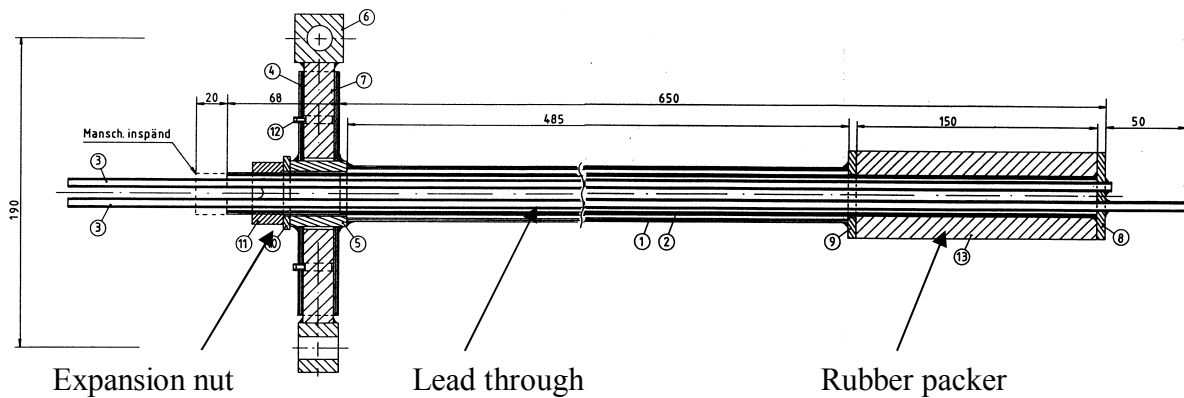
*Figure 2-17 Tunnel-wall borehole.*

### *Instrumentation with mechanical packers*

Six short boreholes (2 m) in the tunnel roof were equipped with mechanical packers, see Table 2-2, Figures 2-18 to 2-20. After insertion into the hole, the pulling of a nut on the centre pipe expanded the packer. Since these holes were directed upwards, the de-aeration required an extra lead-through connected to a tube ending in the innermost part of the borehole. The de-aeration will be made during the backfilling and in boreholes with very little flow one must de-air by filling water through the outer tube.

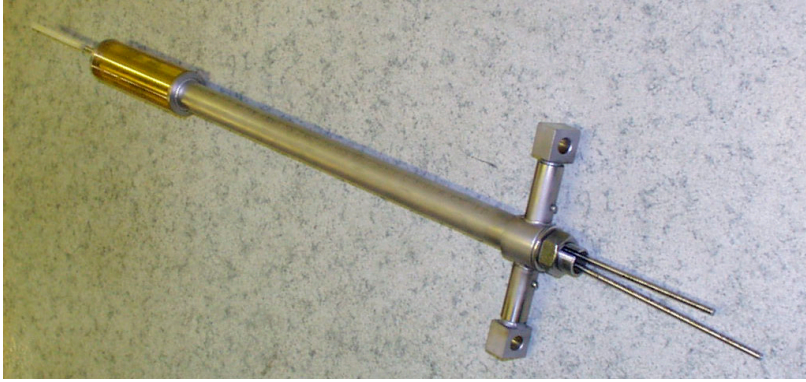
**Table 2-2 Boreholes instrumented with mechanical packers (“Inclination”: inclination of the borehole.).**

Idcode	Length (m)	Inclination (°)
KA3543A01	2.06	-0.8
KA3543I01	2.06	70.5
KA3548D01	2.06	2.7
KA3552A01	2.06	-2.8
KA3552H01	2.1	58.2
KA3553B01	2.02	-37.7

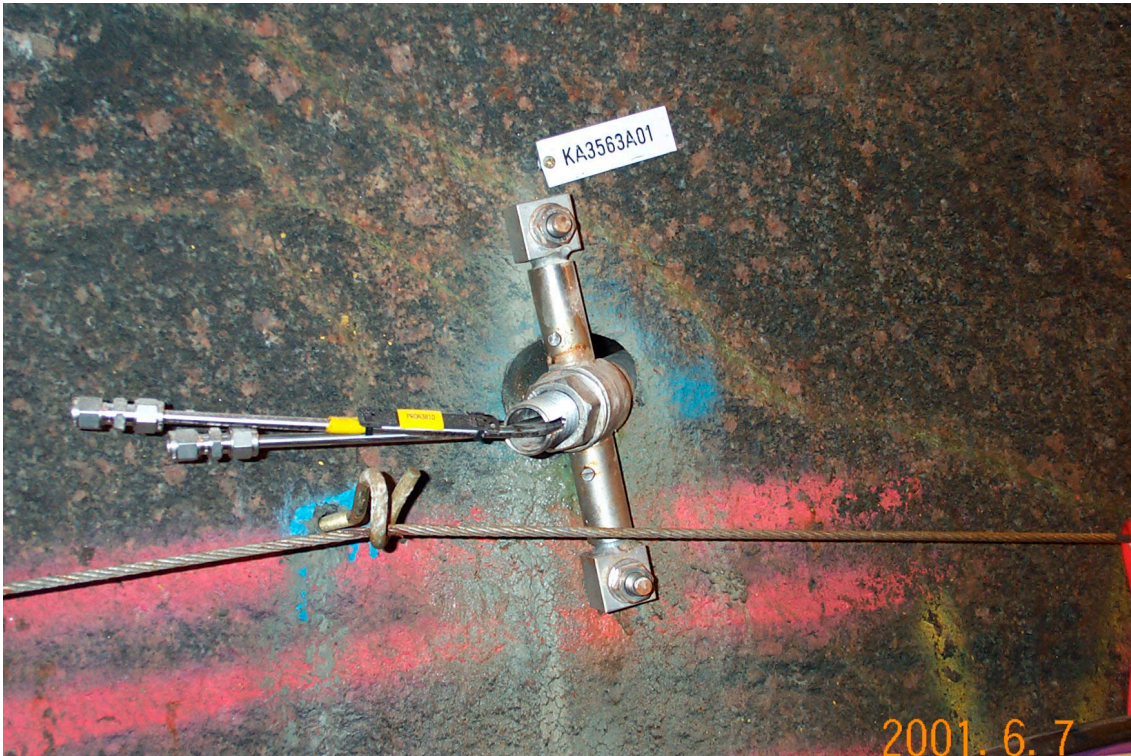


*Figure 2-18 Mechanical packer.*





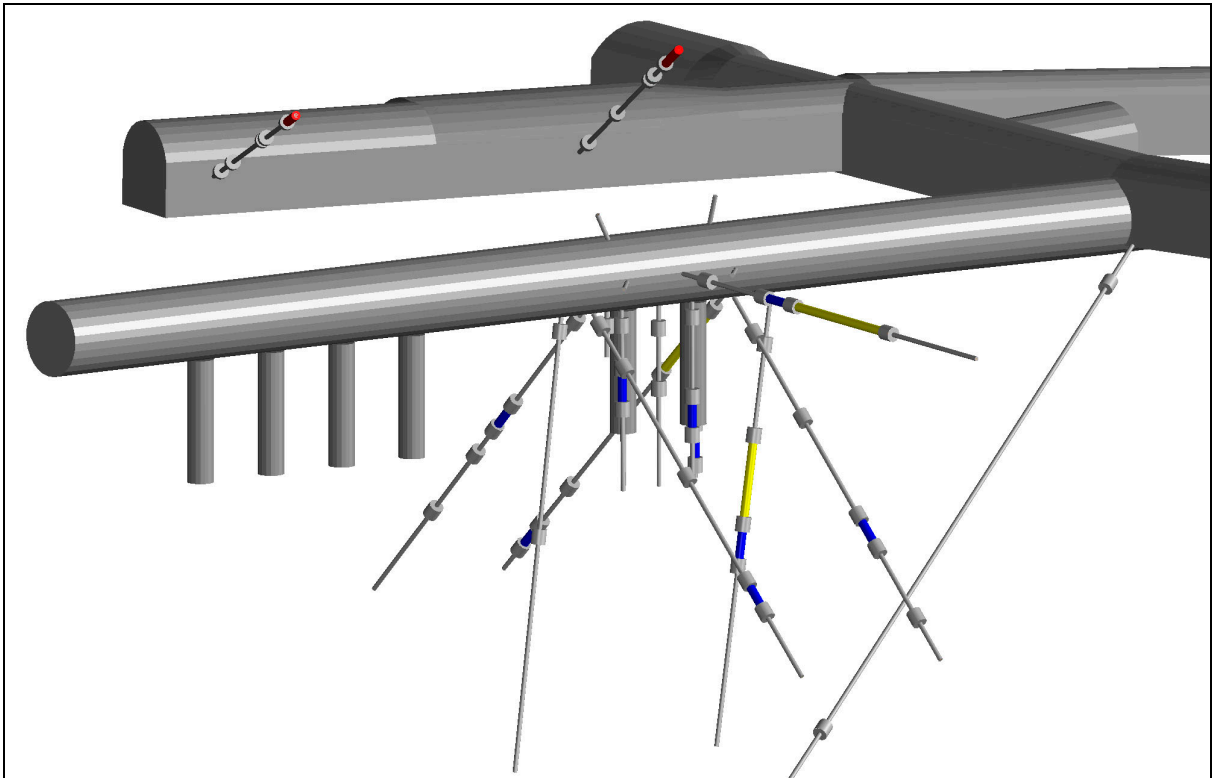
*Figure 2-19 Mechanical packer.*



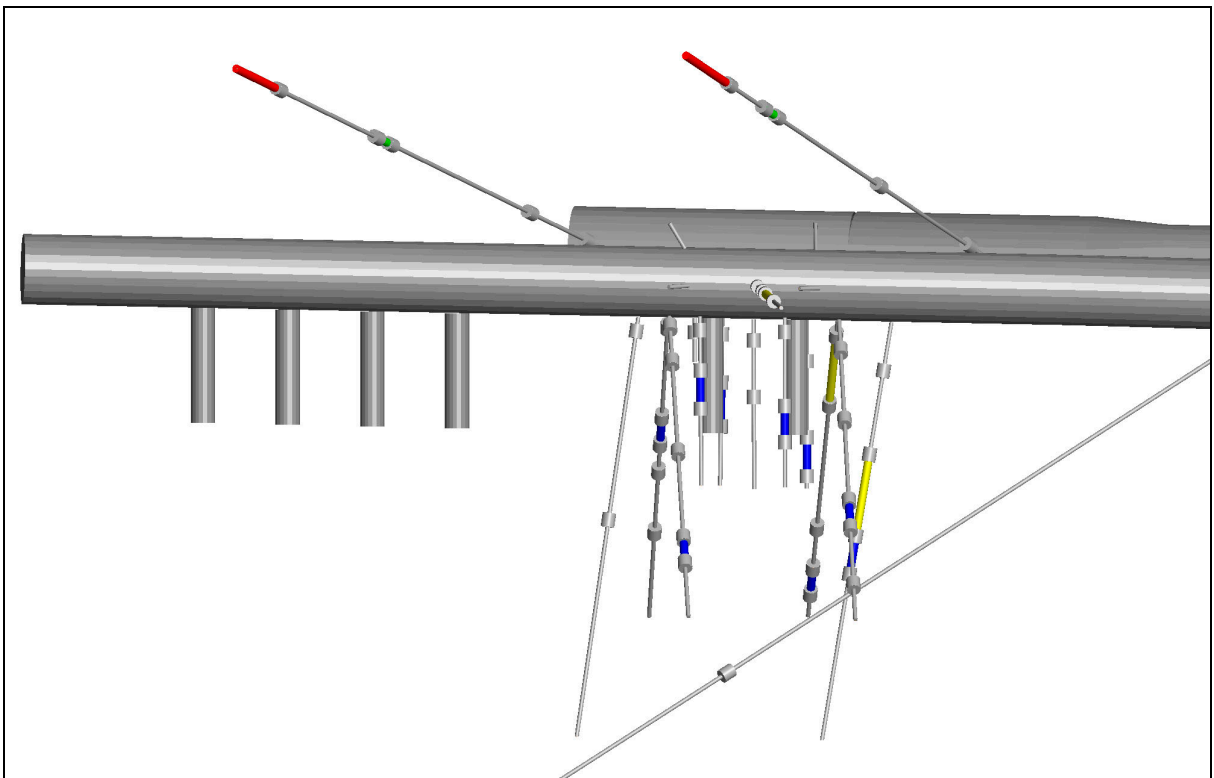
**Figure 2-20** Mounted mechanical packer. (Borehole in figure is located in Section I).

In Figures 2-21 to 2-24, the boreholes with monitoring sections in Prototype Repository Section II are shown. The colours along the boreholes indicate a packer or the type of measurement section:

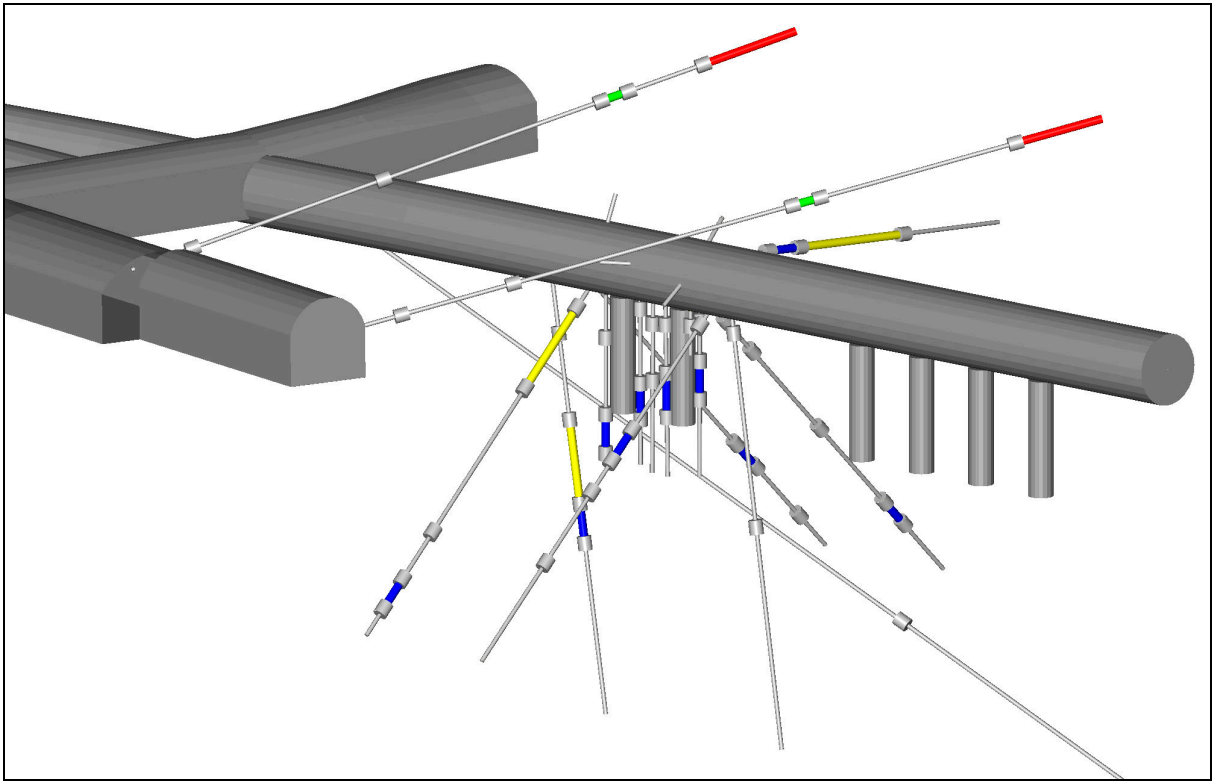
- GREY, wide cylinder: Packer
- NO COLOUR: Pressure section (P)
- RED: Hydrochemical section (HC) + P
- YELLOW: Flow section (F) + P
- GREEN: Circulation section (C) + P
- BLUE: Hydro Mechanical section ( HM) +C+P



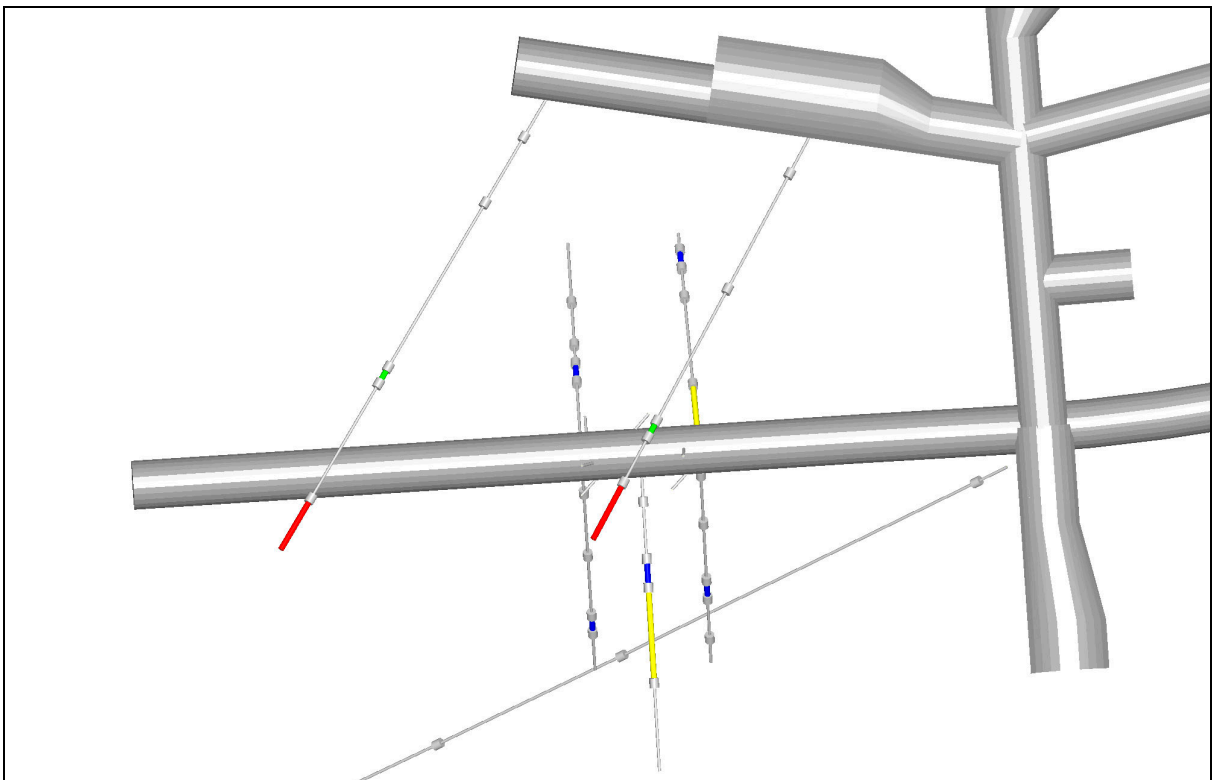
*Figure 2-21 Boreholes with monitoring sections in Prototype Repository Section II.*



*Figure 2-22 Boreholes with monitoring sections in Prototype Repository Section II.*



*Figure 2-23 Boreholes with monitoring sections in Prototype Repository Section II.*



*Figure 2-24 Boreholes with monitoring sections in Prototype Repository Section II.*

### ***Connection to lead-through holes and instrumentation in the G-tunnel***

All instrumentation tubes were finally lead to lead-through holes, see Figures 2-25 and 2-27, connecting sensors cables and tubes in Tunnel A to Tunnel G. Cables and tubes were embedded in the backfill during the backfilling operation, see Figure 2-28.

In the G-Tunnel the instrumentation, panels with transducers etc. are situated, see Figure 2-29. Some borehole sections can be flowed through separate tubes (circulation and flow tubes) and in a few sections it is possible to flow a pressure tube without disconnecting the pressure transducer, see lower figure in Figure 2-29. The equipment for pressurizing the inflatable packers is in the G-tunnel. A pressure vessel filled with water and connected to several packers. The packers are expanded by pressurizing the water-filled pressure vessel (light above) with nitrogen gas (Nitrogen tube, black above).

Boreholes KG0021A01 and KG0048A01 are equipped with a casing that is used for the anchoring the packers, see Figure 2-31.



***Figure 2-25 Tubes and cables being installed in a lead-through hole.***



*Figure 2-26 Stand for cables, tubes and lid for the lead-through holes.*

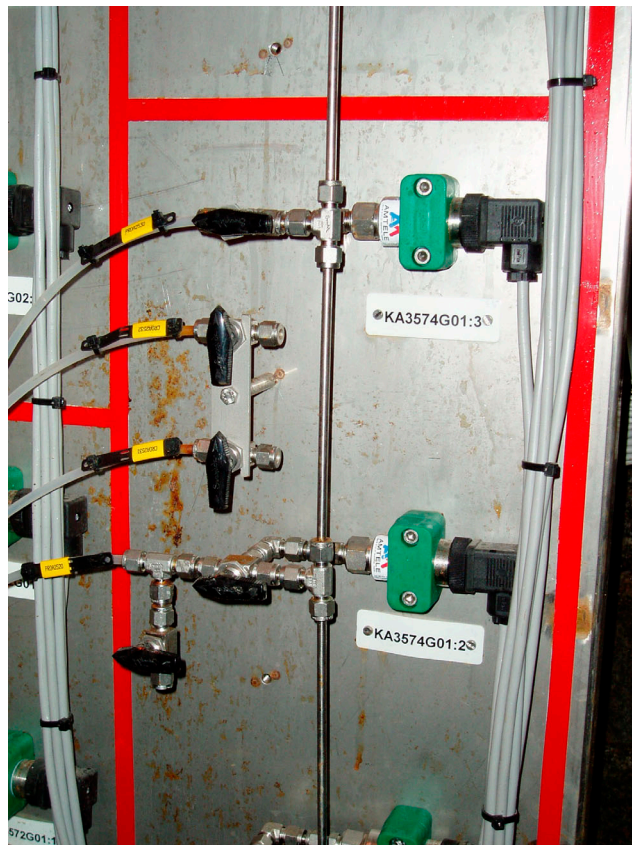
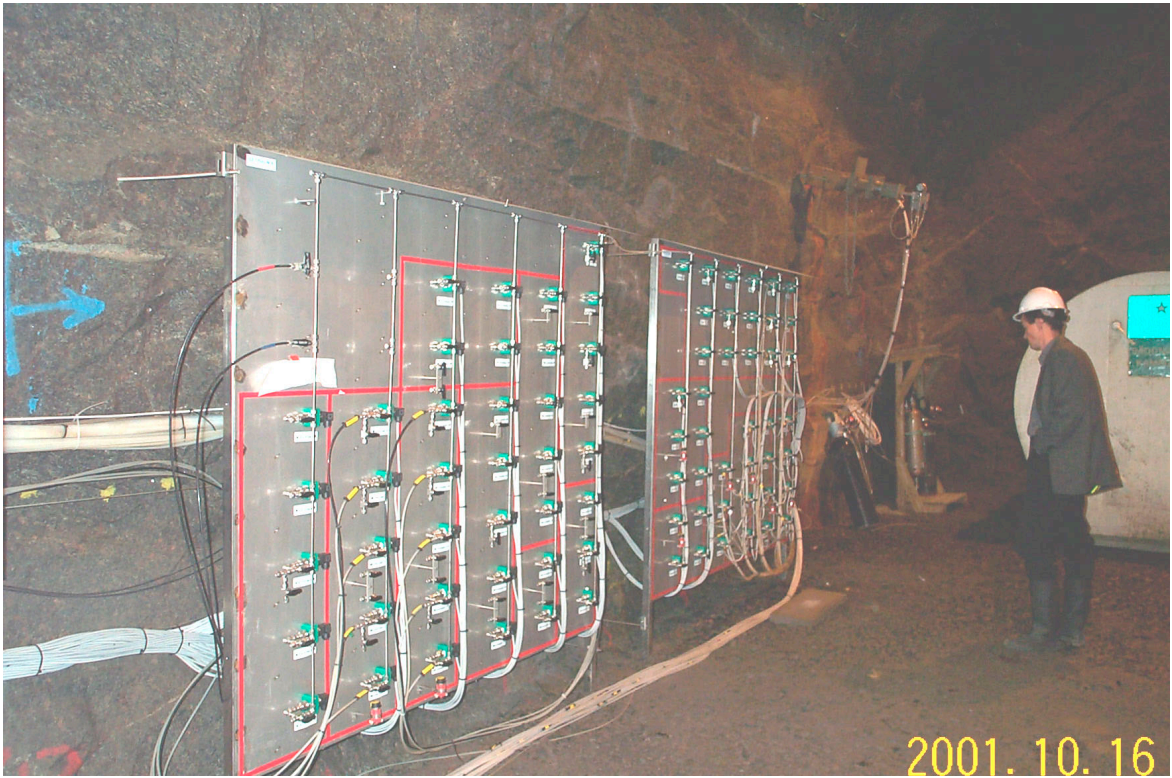


*Figure 2-27 Lead-through holes with lid fixed.*



*Figure 2-28. The connection of cables and tubes from the boreholes to the lid was made successively during the backfilling operation. Cables and tubes were fixed to the surface of the backfilling before commencing a new layer of backfill material.*

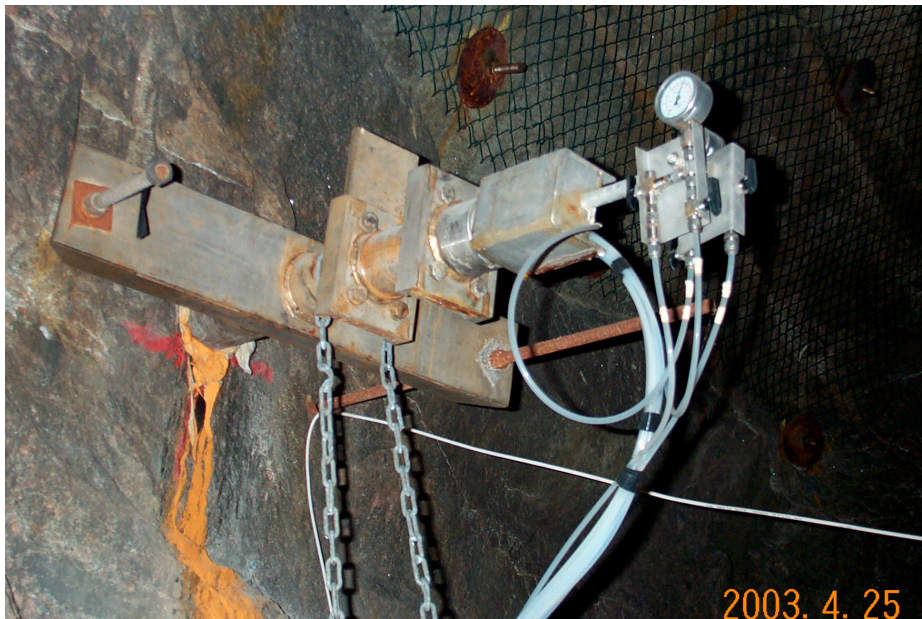




**Figure 2-29** In the G-tunnel, tubes from the borehole sections are connected to pressure transducers (one per bh-section at the panel for transducers), circulation and flow tubes to separate valves and the cables from the deformation sensors to electronic devices. The yellow labels are the ID-labels according to Appendix 4.



*Figure 2-30. The equipment for pressurizing the inflatable packers is in the G-tunnel. A pressure vessel filled with water and connected to several packers. The packers are expanded by pressurizing the water-filled pressure vessel (light above) with nitrogen gas (Nitrogen tube, black above).*



*Figure 2-31. Boreholes KG0021A01 and KG0048A01 are equipped with a casing that is used for the anchoring the packers.*

## **3 Pressure measurements**

### **3.1 Introduction**

The hydraulic properties of the rock, geometry of tunnels and depositions holes, water pressure far away from the tunnels and the hydro-mechanical properties of the backfill and buffer govern the saturation of the buffer and backfill. It is important to measure the water pressure in the rock for the interpretation of the measurements in the buffer and backfill and to sample data useful for the modelling of the saturation process.

### **3.2 Measurements in the boreholes**

As shown in Chapter 2 a large number of boreholes were instrumented with one or several packers. In all packed-off sections, the water pressure will be measured. Each borehole section is connected to a tube of polyamide that via lead-through holes ends in the G-tunnel. All pressure transducers are placed in the G-tunnel to facilitate easy calibration and exchange of transducers that are out of order. The transducers are connected to the HMS system at Äspö Laboratory and it is a flexible system for changing the sampling frequency (Figure 3-1). The maximum scan frequency is every 3<sup>rd</sup> second. During periods with no hydraulic tests, preliminary the sampling (storing a value in the data base) frequency will be every 2<sup>nd</sup> hour with an automatic increase of the sampling frequency if the pressure change since last registration is larger than 2kPa. During hydraulic tests, the sampling frequency may be up to 3<sup>rd</sup> second.



*Figure 3-1. All pressure transducers are connected to the HMS system. In the G-tunnel there is a computer in the HMS system where logging frequencies easily can be changed.*

### **3.3 Modelling**

The pressure measurements will be important for the numerical modelling of the rock mass, buffer and backfill. The first measured data will be useful for defining the initial conditions and the continuous measurements will be useful for future comparison with any predictive modelling involving the rock mass around the Prototype Repository. The pressure measurements during hydraulic tests will also be useful for calibrating and testing the models.

## 4 Dilution measurements

### 4.1 Introduction

Groundwater flow rate is one part that governs the transport of solutes and thus plays a role for the hydro chemical evolution of the groundwater. Groundwater flow rate is difficult to measure in a fractured media but the available technique can provide good indications of hydraulic connections if the hydraulic stress field is changed (with a hydraulic test for example) and can also provide approximate flow rates in the rock mass.

### 4.2 General principles

The groundwater flow in a saturated geological formation can be estimated from dilution measurements, see for example Halevy et al. (1967), Drost et al. (1968), Gaspar and Oncecu (1972). Equation 4-1 is generally used for estimating the groundwater flow (filtration velocity or Darcy velocity). It has been developed for porous media but is also used to evaluate dilution measurements in fractured rock. In Figure 4-2, the dilution curve is illustrated.

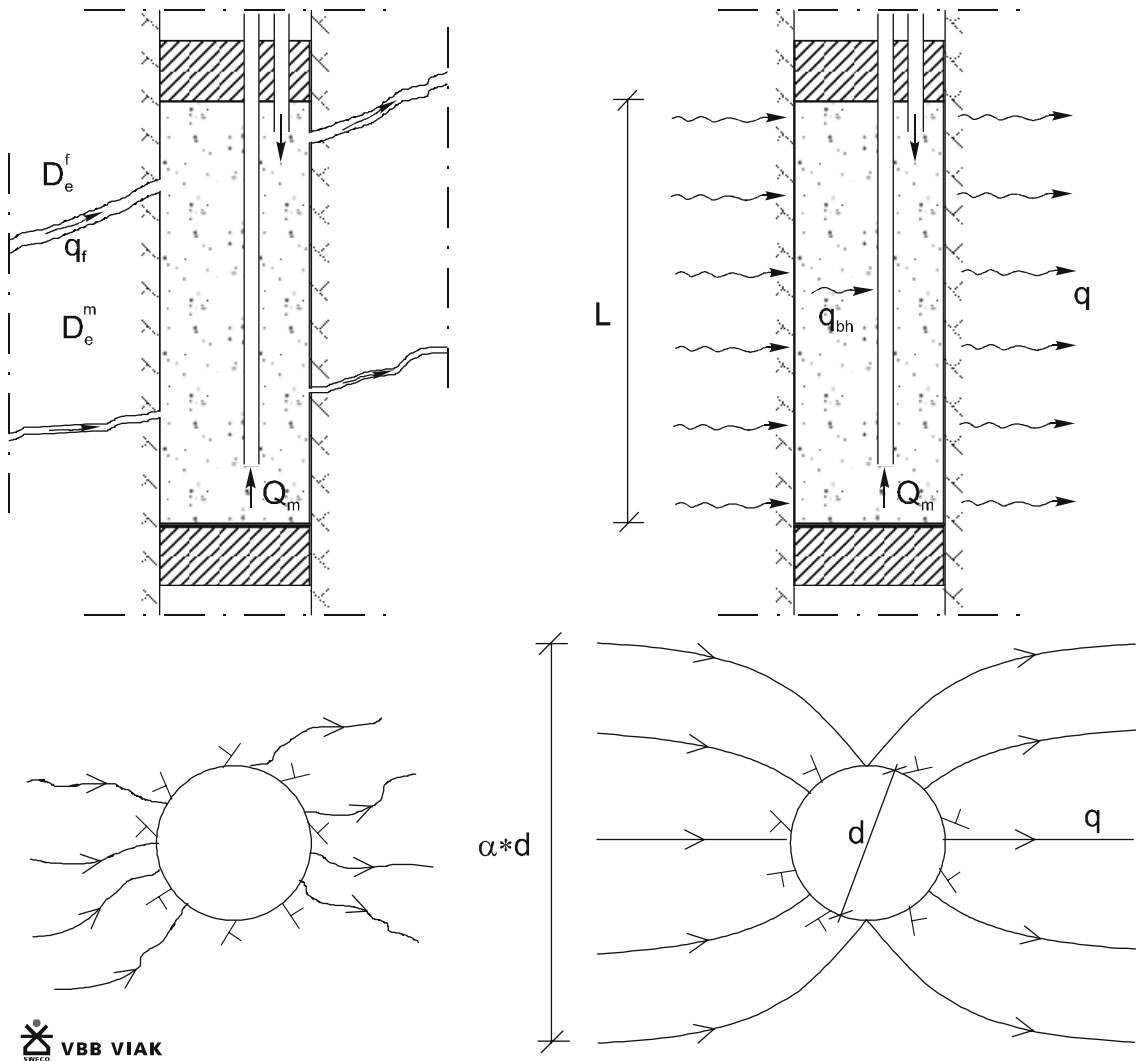
$$q_{bh} = \alpha \cdot q + q_D + q_R = \frac{V}{A \cdot t} \cdot \ln\left(\frac{C}{C_0}\right) \quad (4-1)$$

- $q_{bh}$ : Tracer dilution velocity in the borehole section (m/s)
- $\alpha$ : Correction factor for the hydrodynamic field distortion (-)
- $q$ : Filtration velocity in the formation (m/s)
- $q_D$ : Apparent velocity due to molecular diffusion of the tracer (m/s)
- $q_R$ : Apparent velocity due to effects of vertical current, mechanical mixing etc. (m/s)
- $V$ : Dilution (water and tracer filled) volume of the borehole section (m<sup>3</sup>)
- $A$ : The area of the dilution (measuring) volume cross-section (m<sup>2</sup>)
- $t$ : Time (s)
- $C$ : Tracer concentration at time  $t$  (kg/m<sup>3</sup>)
- $C_0$ : Tracer concentration at time  $t=0$  (kg/m<sup>3</sup>)

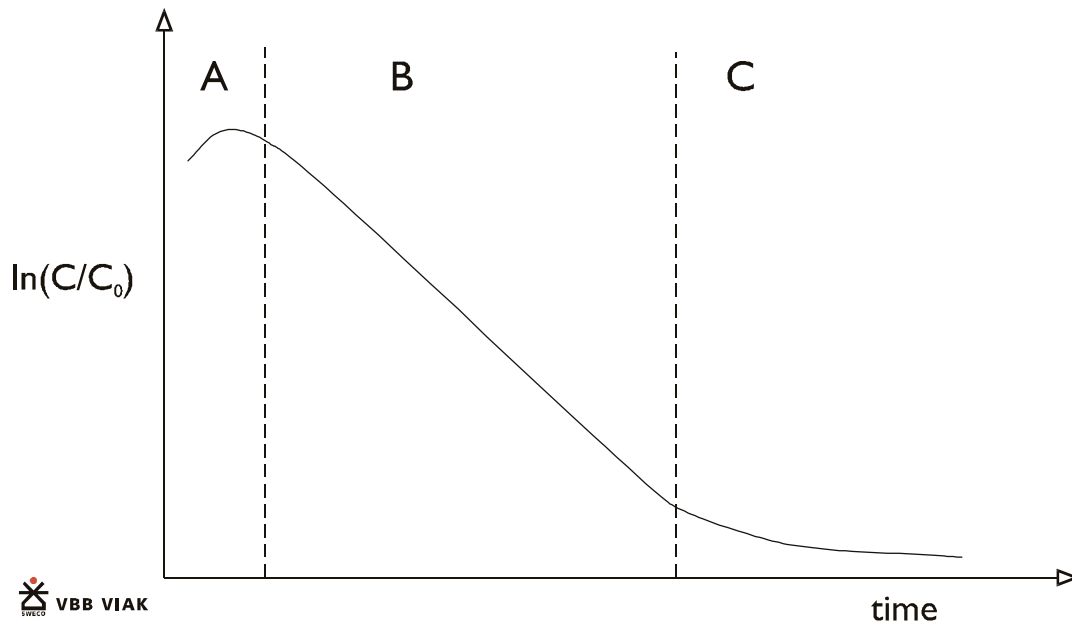
It should be observed that  $q$  in equation 4-1 is also called “Darcy velocity” and should not be confused with the actual transport velocity. The transport velocity is dependent of the kinematic porosity and the transport velocity can thus in crystalline rock be 100 to 10000 greater than  $q$ .

The assumption made in equation 4-1 is that the groundwater flow is perpendicular to the borehole section, see Figure 4-1. The flow  $q_R$  can generally be neglected and the lower measuring limit is then governed by the molecular diffusion of the tracer. The parameter  $\alpha$  depends on the permeability distribution around the borehole. If the permeability is constant around the borehole  $\alpha=2$ . If the permeability is much greater within radius ( $r_2$ ) of about 5 times the borehole radius ( $r_1$ ) compared to outside  $r_2$ ,  $\alpha$  become about 4. If the permeability is less within radius  $r_2$  compared to outside  $r_2$ ,  $\alpha$  may

become less than 1. It is assumed that the tracer is perfectly mixed in the borehole section. It is necessary that the circulation-flow rate ( $Q_m$ ) of the tracer is much greater than  $q_{bh} \cdot A$  to keep the borehole section well mixed. The time needed for a measurement can be decreased if the volume  $V_C$  decreases. By using “dummies” (massive cylindrical bodies with volume  $V_d$ ) in a borehole section (with total borehole volume  $V$ )  $V_C$  decreases to  $V - V_d$ .



**Figure 4-1** Schematic description of dilution measurements. To the left: Flow in fractured crystalline rock. To the right: Ground water flow in a porous medium.  $L$ : length of test section.  $d$ : diameter of the borehole section.  $D_e^m$ : Effective diffusion coefficient of the rock matrix.  $D_e^f$ : Effective diffusion coefficient in the fractures.



**Figure 4-2** Schematic description of a dilution curve. A: Homogenisation in the borehole section. B: Curve used for evaluation of  $q_{bh}$ .

Apparent velocity due to molecular diffusion of the tracer can be estimated by equation 4-2 (Halevy et al, 1967).

$$q_D = \frac{\pi \cdot D_e}{r_1} \quad (4-2)$$

- $q_D$ : Apparent velocity due to molecular diffusion of the tracer (m/s)
- $D_e$ : Effective diffusion coefficient of the tracer ( $m^2/s$ )
- $r_1$ : Radius of borehole in test section (m)

If  $q_D$  can be calculated, it should be included in equation 4-1 when calculating  $q$ . However, it may be difficult to estimate  $D_e$  for a particular borehole section.

### 4.3 Measurements in the boreholes

According to Byegård et al. (1998) the effective diffusion coefficient for the rock matrix of Äspö diorite is in the range  $4 \cdot 10^{-14} - 1 \cdot 10^{-13} m^2/s$ . Diffusion coefficient of a tracer in water with an ionic strength less than 0.5 and a temperature of 20-25 °C is about  $1 \cdot 10^{-9} - 2 \cdot 10^{-9} m^2/s$ .

The measured transmissivities (T) of test sections with 1 or 3 m length (L) in the Prototype Repository are in the range  $1 \cdot 10^{-12} - 5 \cdot 10^{-6} m^2/s$  (Rhén and Forsmark, 1998a,b, Forsmark and Rhén, 1998a). The transport aperture is expected to be in the order of  $10^{-5} - 10^{-2} m$  in a test section with 1 or 3 m length (Rhén et al, 1997). Estimated mean flow porosity ( $n_e$ ) and effective diffusion coefficient of a test section are estimated

in Table 4-1. Hydraulic conductivity estimated as T/L. Apparent velocity due to molecular diffusion of the tracer, calculated according to equation 4-2, is also shown in Table 4-1. Bore diameter assumed is 76 mm.

The hydraulic gradient in the near field of the open tunnel is in the range 10-25 (Forsmark and Rhén, 1998a). It is expected that the hydraulic gradient may be as low as 1-0.1 during the operation phase according to Svensson (2001).

**Table 4-1 Estimated mean flow porosity and effective diffusion coefficient as function of transmissivity of a borehole section with length 1-3 m.**

Hydraulic conductivity (K)	Estimated range for flow porosity ( $n_e$ )	Estimated effective diffusion coefficient ( $D_e$ )	Apparent velocity due to molecular diffusion of the tracer ( $q_D$ )
(m/s)	(-)	(m <sup>2</sup> /s)	(m/s)
$10^{-10}$	$5 \cdot 10^{-6} - 10^{-4}$	$10^{-14} - 10^{-13}$	$10^{-12} - 10^{-11}$
$10^{-8}$	$10^{-5} - 5 \cdot 10^{-4}$	$10^{-14} - 5 \cdot 10^{-13}$	$10^{-12} - 5 \cdot 10^{-11}$
$10^{-6}$	$10^{-4} - 5 \cdot 10^{-3}$	$10^{-13} - 5 \cdot 10^{-12}$	$10^{-11} - 5 \cdot 10^{-10}$

**Table 4-2 Estimated filtration velocity (q) with assumed hydraulic conductivity (K) and hydraulic gradient (i).**

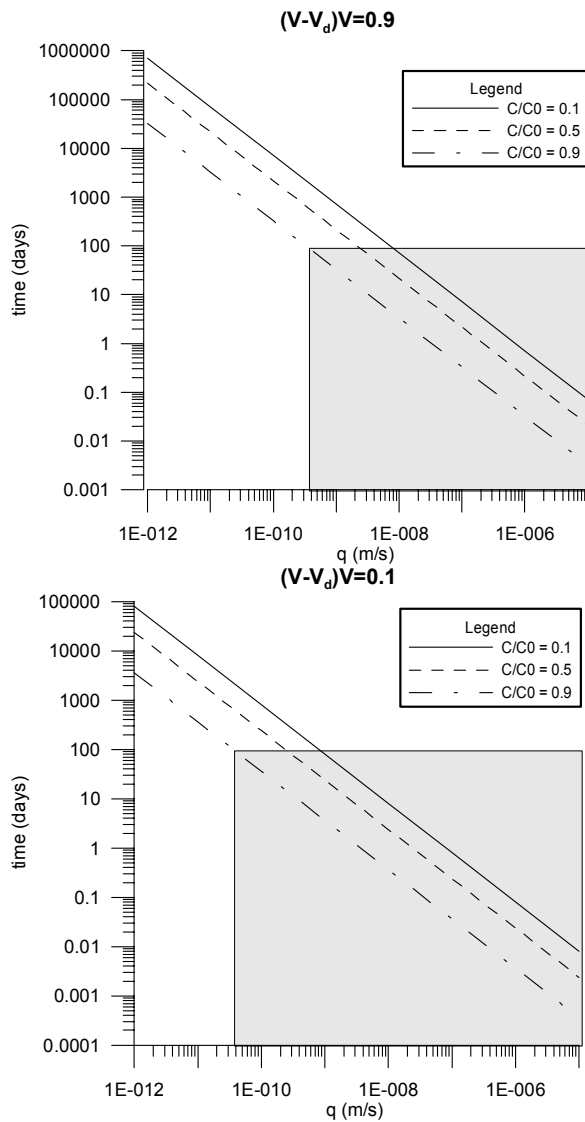
Hydraulic conductivity (K)	Hydraulic gradient (i)	Estimated filtration velocity (q)
(m/s)		(m/s)
$10^{-10}$	10	$10^{-9}$
$10^{-10}$	0.01	$10^{-12}$
$10^{-8}$	10	$10^{-7}$
$10^{-8}$	0.01	$10^{-10}$
$10^{-6}$	10	$10^{-5}$
$10^{-6}$	0.01	$10^{-8}$

Estimated time for dilution measurements is shown in Figure 4-3. According to Table 4-1, the lowest filtration velocity that can be estimated is about  $10^{-11}$  m/s, assuming that q should be some 10 times greater than  $q_D$  and that it is a single fracture (low total flow porosity). As can be seen in the figure the lowest filtration velocity that can be estimated



within reasonable time is about  $10^{-10}$  m/s. According to Tables 4-1 and 4-2 it should be possible to measure flow rates in sections with  $K$  around  $10^{-11}$ - $10^{-10}$  m/s in before, or just in the beginning of, the operation phase of the Prototype Repository and in sections with  $K$  around  $10^{-10}$ - $10^{-9}$  m/s.

Only a few sections will be measured according to Chapter 2 but the measurements should indicate the magnitude of the flow rates and to some extent the variability of the flow rates.



**Figure 4-3** The time interval, for 0.1, 0.5 and 0.9 of the initial tracer quantity takes to be carried through borehole out of the formation, for different flow velocities in a borehole section with diameter 76 mm.  $V$ : total volume of borehole section.  $V_d$ : Volume of dummy and other space filling parts in the borehole section.

## **4.4 Modelling**

The dilution measurements will be useful for the numerical modelling of the rock mass. The first measured data will to some extent be useful for calibration of the model and the continuous measurements will be useful for future comparison with any predictive modelling involving the rock mass around the Prototype Repository.

## 5 Hydrochemical sampling in the boreholes

### 5.1 Introduction

Both the chemical stability of backfill material and the corrosion rate of the canister are important areas of uncertainty in repository safety and performance assessment. These are processes that depend on the hydro chemical characteristics of the near field. The solubility and migration characteristics of several radionuclides are also highly dependent on the chemical composition of the groundwater. Other factors affecting radionuclide mobility are the hydraulic and mineralogical properties of the rock. A suitable description of the chemical environment is required in order to demonstrate the proper function of the engineered barriers of the Prototype Repository.

Microorganisms have the capability to reduce important groundwater components such as sulphate to sulphide and to produce and consume gases. Relevant microbial reactions should be included in the performance assessment for a HLW repository. The Prototype Repository will not be a sterile environment and microbial activity that influence the hydro chemical situation must, therefore, be studied.

The objectives for the hydro chemical sampling program, which is discussed in Puigdomenech and Pedersen (1999), are:

- Monitoring the chemical/microbial function of the Prototype Repository
- Verification of chemical/microbiological Models & Hypotheses
- Effect of temperature field on groundwater-rock interactions
- Bentonite redox chemistry
- Microbes
- Colloids
- Redox

Bentonite packers could possibly induce massive contamination of the Prototype near field with bentonite colloids, and this would jeopardize the chemical monitoring. Therefore, boreholes were instrumented with bentonite packers where the bentonite was enclosed in rubber containers, cf. Section 2.2.2.

To study the redox conditions it is important to prevent O<sub>2</sub> from diffusing into the sampling system.

## 5.2 Sampling in borehole sections

Sampling will be made close to the deposition holes and up to about 50 m from the TBM tunnel. The sampled section will have transmissivities ranging from  $10^{-10} - 10^{-6} \text{ m}^2/\text{s}$ . The location of these sampling points for hydrochemistry (HC) is described in detail in Table 2-1. As can be seen in the Table 2-1 no hydro chemical section is found for boreholes in tunnel section II but in boreholes KG0021A01 and KG0048A01.

In all sections for hydro chemical sampling, all tubes going through the section will be of stainless steel. Sampling tubes will be made of PEEK and if there is a separate tube for pressure measurements in the hydrochemistry section, it will be made of polyamide.

Water samples can easily be taken from flow sections (F) and circulation sections (C). Separate valves on some of the pressure tubes in the G-tunnel coming from the borehole sections where only pressure is measured will make it easy to take water samples from those sections.

The analyses will be done at level Class 4 in accordance with SKB's classification, which includes  $^2\text{H}$  and  $^{18}\text{O}$  determinations. C and S isotope analyses and redox sensitive  $\text{HS}^-$  and  $\text{NH}_4$  will be done routinely. At the closure of the Prototype Repository the hydro chemistry sections will be sampled every week and later on every 6 months.

In the case of packed-off sections for flow measurements, chemical sampling and analyses will be performed at level Class 3 with supplement analyses of  $^2\text{H}$  and  $^{18}\text{O}$ . During the operation of the Prototype Repository, activation sampling will take place every week and later on after consideration.

## 5.3 Modelling

The aim of the modelling is to determine possible heat-up effects on hydraulic flows and chemical reaction rates, as well as effects from the backfill bentonite on the chemical composition and colloid content of the near-field groundwater. Predictive model results will also be used to check the validity of the model formulation, and of the thermodynamic databases.

Geochemical modelling will concentrate on the data collected from the near-field double packer sections before the backfilling of the Repository, and during operation.

## 6 Flow sections

### 6.1 Introduction

A large number of hydraulic tests have been performed in the boreholes around the Prototype Repository in order to characterize the hydraulic properties of the rock mass. During the operation of the Prototype Repository interference tests will be made using different flowing borehole sections. The interference tests will be repeated a number of times during the operation period. A few borehole sections considered to be more suitable for flowing have been instrumented with one or two tubes for flowing and a separate tube for pressure measurement.

Besides facilitating hydraulic tests, the flowing sections make it easy to take water samples for chemical analysis.

### 6.2 Sampling and hydraulic tests in borehole sections

For the long-time hydrogeological monitoring, plastic and steel tubes will be used to enable the process of taking water samples for chemical analyses and hydrogeological tests. The flow in tubes depends on the tube diameter and the friction coefficient of the tube wall. The calculations below indicate the possible flow rates with different tube diameter.

The tubes in the long-term test are about 100 m long. The pressure head between the inflow (pressure in packed-off section) and the outflow is expected to be around 300 m. The temperature in the water is assumed to be between 15°C and 50°C, which gives a kinematic viscosity varying between  $1.141 \cdot 10^{-6} \text{ m}^2/\text{s}$  and  $0.556 \cdot 10^{-6} \text{ m}^2/\text{s}$ . The tube wall is assumed to be smooth. With these facts in the energy equation, the predicted flow was calculated for three different tube diameters: 1 mm, 2 mm and 4 mm. The results from the calculations are presented in Table 6-1.

In the tube with 1 mm inner diameter laminar flow will develop and in the tube with 4 mm inner diameter, turbulent flow will develop as in the 50°C water in the 2 mm tube. However, with 15°C water in the 2 mm tube a complicated stadium of something between laminar and turbulent flow will develop. In this case, the outflow has been calculated as if turbulent.

The flow in the 1-mm tube is only 2 % of the flow in the 4 mm tube and the flow in the 2 mm tube is 10-15 % of the flow in the 4 mm tube.

**Table 6-1** The table presents the results from the calculations. Q stands for flow rate, Re stands for Reynolds's number, T<sub>water</sub> stands for the water temperature in the rock and D<sub>tube</sub> stands for the inner tube diameter.

		D <sub>tube</sub> = 1 mm	D <sub>tube</sub> = 2 mm	D <sub>tube</sub> = 4 mm
T <sub>water</sub> = 15°C	Q (m <sup>3</sup> /s)	6,3*10 <sup>-7</sup>	5,1*10 <sup>-6</sup>	3,5*10 <sup>-5</sup>
	Q (l/min)	0,038	0,308	2,077
	Re	700	2900	9500
T <sub>water</sub> = 50°C	Q (m <sup>3</sup> /s)	9,7*10 <sup>-7</sup>	5,8*10 <sup>-6</sup>	5,1*10 <sup>-5</sup>
	Q (l/min)	0,058	0,348	3,034
	Re	1650	6600	29000

### 6.3 Modelling

Hydraulic tests and geological characterization made up to Spring 2001 are the base for setting up numerical groundwater flow models. Interference tests made before year 2000 can be used for calibration of the models. Interference tests made during the operation period may be used for comparison with predicted responses to gain confidence in the models. The repeated interference tests may indicate changes in the hydraulic responses which then may be useful for assessing the THM behaviour of the rock mass.

## **7 Temperature measurements**

### **7.1 Introduction**

The thermal properties of the rock, geometry of tunnels and depositions holes, the undisturbed temperature, thermal properties of the backfill and buffer and the heat generated in the canisters govern temperature evolution in the rock mass, buffer and backfill. It is therefore important to measure the temperature in the rock for the interpretation of the measurements in the buffer and backfill and to sample data useful for the modelling of the thermal process.

### **7.2 Measurements in the boreholes**

As shown in Chapter 2 ten boreholes are instrumented with two deformation sensors each around the prototype tunnel and in one borehole in the G-tunnel is instrumented with two deformation sensors. These measuring points will mainly serve to measure the deformation but the strain gauges also measures the temperature. There will be other deformation measurements in Section II giving more temperature measurement points in the rockmass.

### **7.3 Modelling**

The temperature measurements will be important for the numerical modelling of the rock mass, buffer and backfill. The first measured data will be useful for defining the initial conditions and the continuous measurements will be useful for future comparison with any predictive modelling involving the rock mass around the Prototype Repository.





## **8 Hydro Mechanical sections**

### **8.1 Introduction**

During storage of nuclear waste in the rock mass the temperature will increase due to the heat loss from the canisters with spent fuel. This will increase the rock stresses and the fractures will close.

It is of great interest to investigate the magnitude of this effect on the fracture transmissivity since the fracture transmissivity is essential of two reasons. First, enough transmissivity is needed to provide the bentonite buffer with water if no artificial moistening of the buffer is arranged. Secondly, the transmissivity should be as low as possible in order to minimise the hydraulic contact with the canisters. The increased temperature will decrease the transmissivity, which in principal is positive in perspective of Safety Assessment. The last effect is however limited in time and may not be of any greater importance in Safety Assessment.

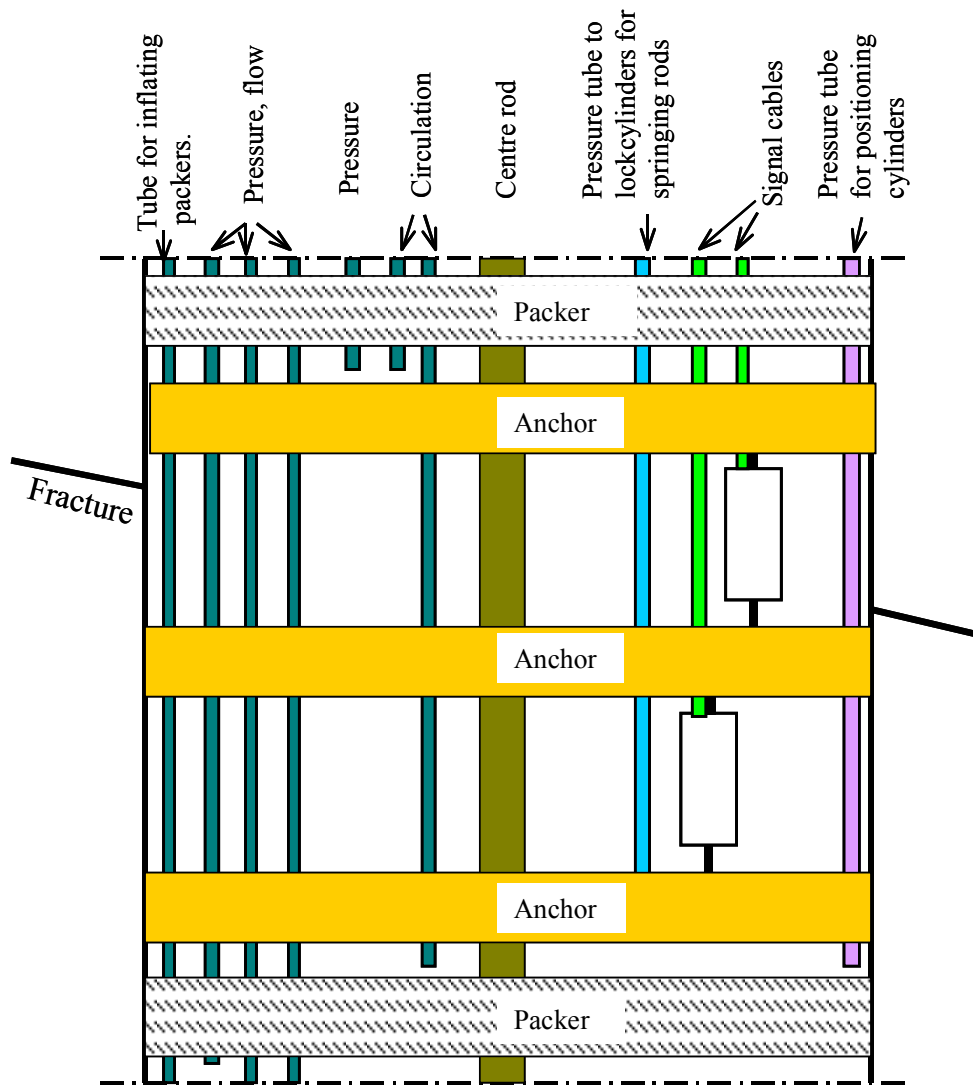
### **8.2 Hydro Mechanical measurements in borehole sections**

In order to investigate the hydro mechanical response of the fractures as a result of the increased thermal load, two different approaches are considered.

The first approach is to measure the change of the fracture width as function of temperature and time. As pointed out in Chapter 2 the deformation is both measured for the intact rock as for a section with one or more fractures, see Figure 8-1.

The second approach implies that the mechanical response is evaluated indirect by using the results from hydraulic tests. Hydro tests will be performed in the same sections as the mechanical measurements are made.

Deformation measurements will be made continuously. Hydraulic tests will be made a number of times during the operation period for the ten measurement sections. Most tests will be made during the first years of operation when the largest deformations are expected to be measured.



*Figure 8-1 Schematic figure of the measurement equipment and measurement sections.*

### 8.3 Modeling

The stresses expected from the increased temperature have been modeled (Claeson et al, 2001) and these results have been used to estimate the expected decrease in transmissivity of the fractures in Alm and Rhén (2003). The conclusions were:

- The hydraulic response will in general be decreased transmissivity. The decrease will be larger the closer the fractures are to the canisters.
- The transmissivity will be reduced to something between 10 and 80 percent of the in-situ values.
- The fracture closure will be in the range of 5-70 micrometer.
- The hydraulic and mechanical responses on the fracture depend on the orientation of the fracture relative the stress field.
- Major part (~80%) of the increase in stress and temperature is reached within two years.
- The temperature load will be uniformly distributed in the rock mass. This implies that the ratio between  $\sigma_1$  and  $\sigma_3$  will be more or less constant and the risk of shearing will be low in the rock mass.

The measurements will make it possible to compare the results with the theoretical models used in Alm and Rhén (2003).



## References

- Alm P, Rhén I, 2003 (In press).** Hydro-mechanical behavior of fractures due to excavation and thermal load, Prototype Repository, SKB IPR XX-XX
- Byegård J, Johansson H, Skålberg M, Tullborg, E-L, 1998.** The interaction of sorbing and non-sorbing tracers with different Äspö rock types. Sorption and diffusion experiments in the laboratory scale, SKB TR-98-18
- Claeson C., Dahlström L.-O., and Sandén M., 2001 (In prep):** Finite element analyses of mechanical consequences due to the rock excavation and thermal load. SKB International Progress Report, IPR- XX-XX, Stockholm.
- Drost W, Klotz D, Koch A, Moser H, Neumaier F, Rauert W, 1968.** Point dilution methods of investigating groundwater flow by means of radioisotopes. Water Resources Research, Vol. 4, No. 1, pp 125-146.
- Forsmark T, Rhén I, 1999.** Äspö HRL - Prototype Repository Hydrogeology - Drill campaign 3A and 3B. SKB, IPR-00-08
- Gaspar E, Oncecu M, 1972.** Radioactive tracers in hydrogeology, Elsevier Publ. Comp.,
- Halevy E, Moser H, Zellhofer O, Zuber A, 1967.** Borehole dilution techniques: A critical review. Proceedings of the symposium on isotopes in hydrology in Vienna, 14-18 November 1966. International Atomic Energy Agency
- Persson G, Broman O, 2000.** Äspö Hard Rock Laboratory, Prototype Repository, Project plan, FIKW-CT-2000-00055, SKB, IPR-00-31
- Puigdomenech I, Pedersen K, 1999.** Prototype Repository. Test Plan for subtask. Sampling and monitoring of microbial activities and Chemical conditions during 20 year of operation, SKB, IPR-99-34
- Rhén I, Gustafson G, Stanfors R, Wikberg P, 1997.** Äspö HRL - Geoscientific evaluation 1997/5. Models based on site characterisation 1986-1995. SKB TR 97-06.
- Rhén I, Forsmark T, 1998a.** Äspö HRL - Prototype Repository, Hydrology - Drill campaign 1. SKB PR HRL 98-12.
- Rhén I, Forsmark T, 1998b.** Äspö HRL - Prototype Repository, Hydrology - Drill campaign 2. SKB PR HRL 98-22.
- Rhén I, Forsmark T, 2001.** Äspö HRL - Prototype Repository, Hydrology, Summary report of investigations before the operation phase, SKB IPR-01-65.
- Svemar C, Pusch R, 2000.** Äspö Hard Rock Laboratory, Prototype Repository, Project description, FIKW-CT-2000-00055, SKB, IPR-00-30
- Svensson U, 2001.** Groundwater Flow, Pressure and Salinity around the Prototype Repository, Continuum model No 1, SKB, IPR-01-40



## APPENDIX 1

### Monitoring configuration of boreholes in tunnel section II

- The diagram "*Distribution of hydraulic conductivity*" shows results from investigations detailed in Rhén and Forsmark (1998a,b, 2001) and Forsmark and Rhén (1999b). The bars show estimates of hydraulic conductivity  $K_{sec}$  of sections in each borehole based on flow logging, using a double-packer system, done in the borehole after the completion of drilling.

The entire borehole was tested during a pressure build-up test and if radial flow occurred the evaluation of the transmissivity ( $T_{tot}$ ) was made using a radial flow model (Jacob semi-logarithmic evaluation). In some of the holes radial flow could not be identified and a relationship for transforming the specific capacity to a transmissivity value presented in Rhén et al. (1997) was used. See Rhén and Forsmark (1998a,b, 2001) and Forsmark and Rhén (1999b) for details.

The flow rate  $Q_{sec}$  of the section were used to scale the evaluated whole borehole transmissivity  $T_{tot}$  to get a section transmissivity  $T_{sec}$  using the equation below:

$$T_{sec} = [Q_{sec} \cdot T_{tot}] / Q_{tot}$$

$Q_{tot}$  is the flow rate of the whole borehole

The transmissivity value was later divided by the section length to get the estimate of  $K_{sec}$ .

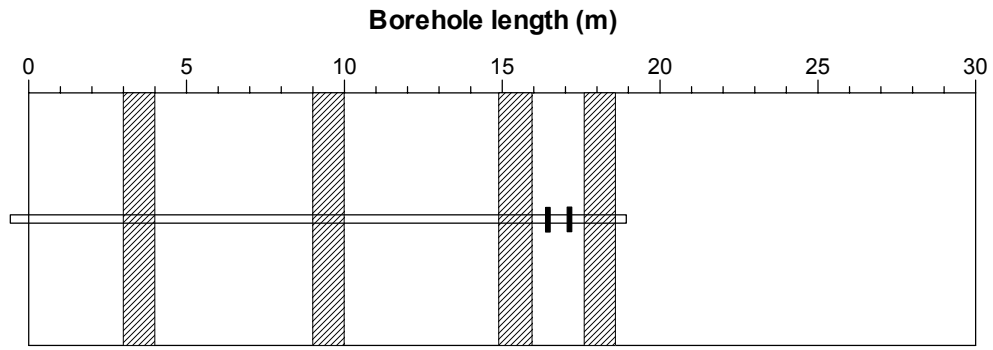
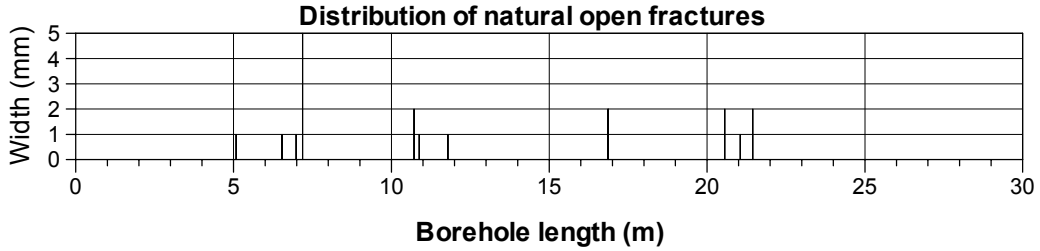
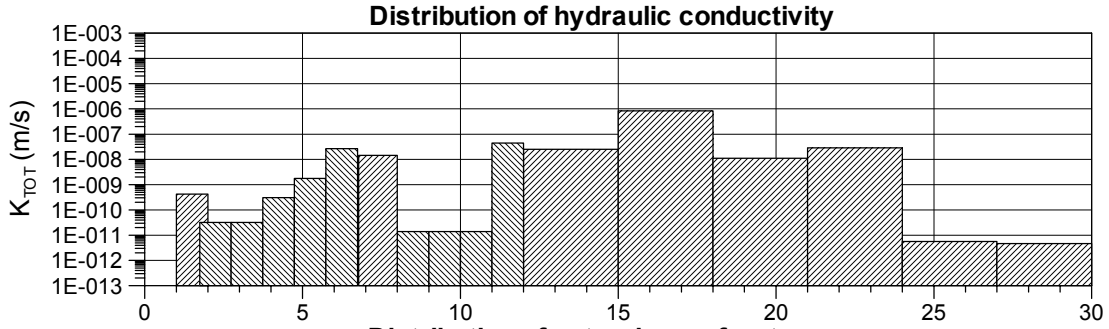
Some of the borehole sections were tested separately with a pressure build-up test (parts of the borehole with higher inflow rates) and reported in the references above. In most cases these results are similar to the  $T_{sec}$  values, but in some cases a difference occurs.

In a few boreholes it was never performed flow logging with a double packer system. In these cases the cumulative flow (L/min) measured with the UCM flow logg is shown in the figures.

- The diagram "*Distribution of natural open fractures*" shows the result of the analysis of studying BIPS images of the borehole walls. BIPS (Borehole Image Processing System) is a borehole-TV system. The purpose is to indicate where potential water-bearing fractures may be located in the hole. From the image an approximate mean width is estimated. If the fracture is judged open, but less than 1 mm wide the width has been set to 1 mm. It should be observed that the width interpreted from the images can not be used as a hydraulic effective aperture.
- The packers in the holes are mounted on and positioned by a solid rod as indicated in the diagrams showing the monitoring configuration.
- In some of the holes (KA3539G, KA3542G02, KA3554G01 and KA3554G02) the polyamid tube for the outermost part of the hole have been replaced by steel tubes. This is indicated in the drawings.

## PACKER POSITION

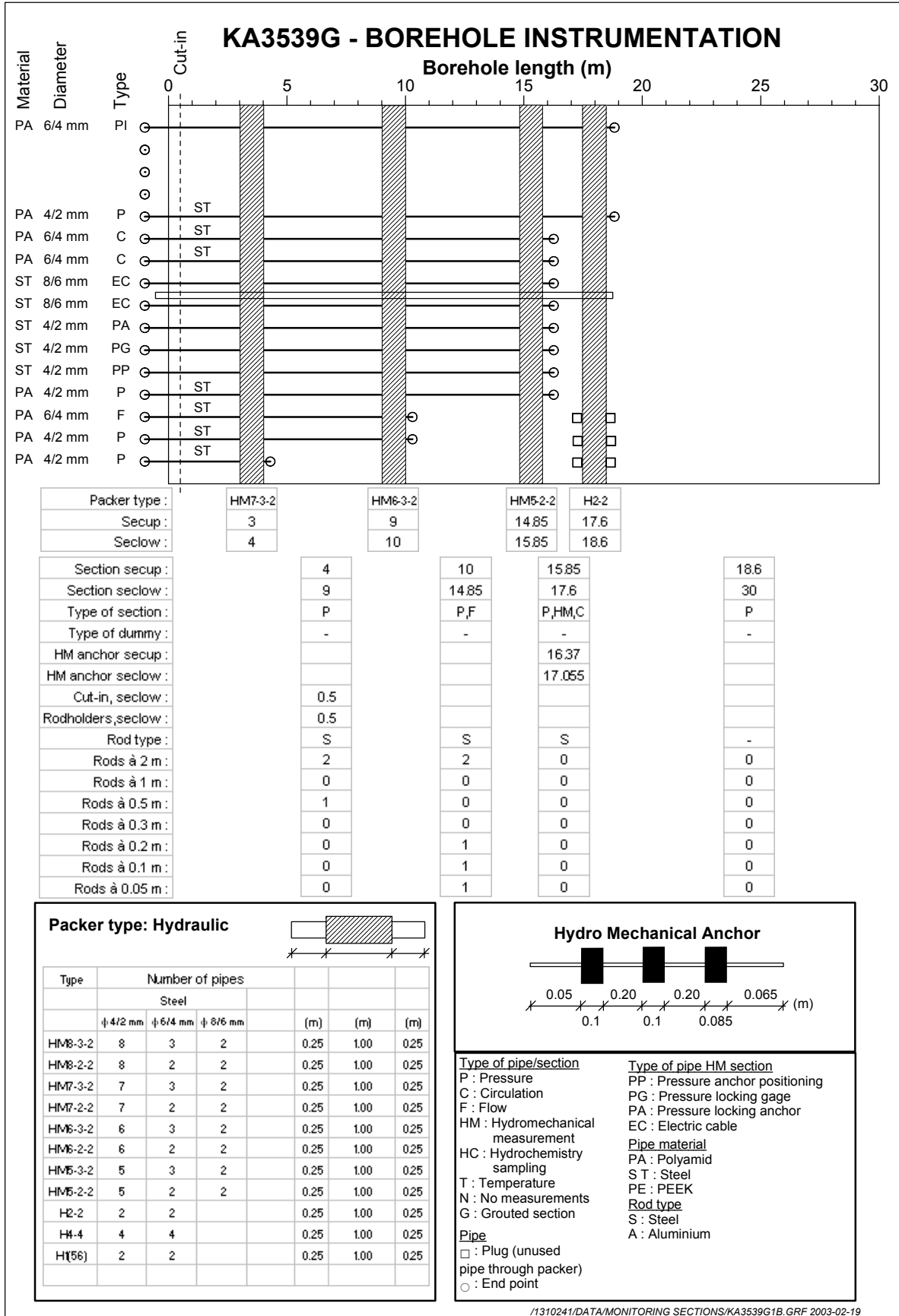
Borehole name: <b>KA3539G</b>	Date design: 2003-02-20
Borehole diameter: 76 mm	Name: TFK
Borehole length: 30.01 m	Remark:
Borehole inclination: 80° down	



Section setup :	4	10	15.85	18.6
Section seclow :	9	14.85	17.6	30
Type of section :	P	P,F	P,HM,C	P
Type of dummy :	-	-	-	-
HM anchor setup :			16.37	
HM anchor seclow :			17.055	

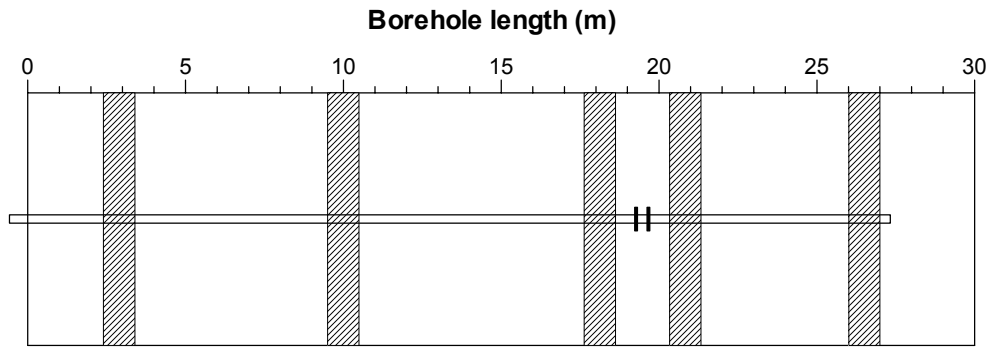
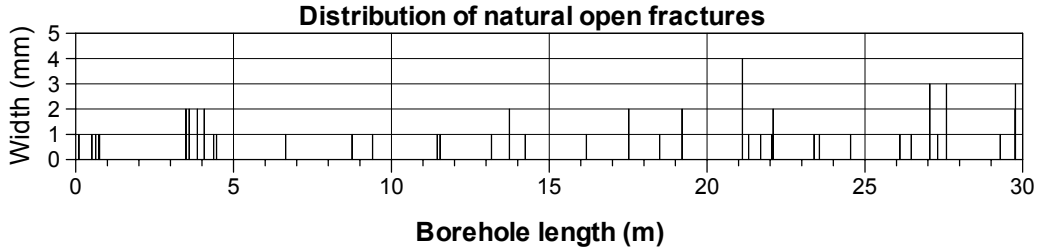
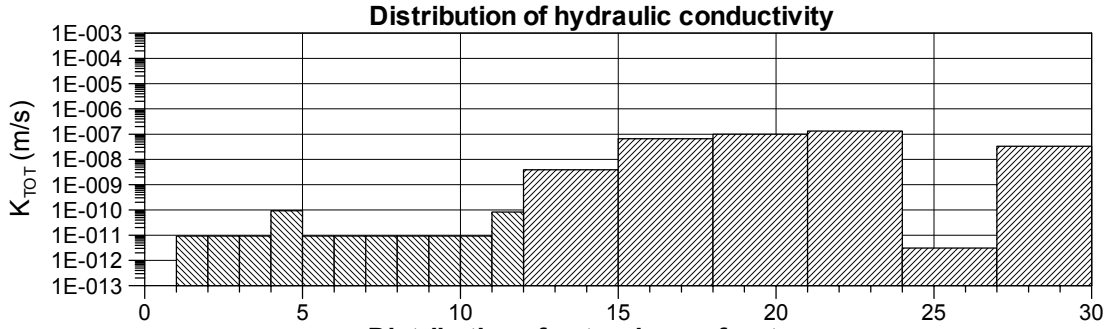
<b>Type of measurement section</b>		<b>Type of dummy</b>	
P : Pressure		PE : PEEK	
C : Circulation		HD : HD1000	
F : Flow			
HM : Hydromechanical measurement		PACKER	ANCHOR
HC : Hydrochemistry sampling			
T : Temperature			
N : No measurements		DUMMY	
G : Grouted section			





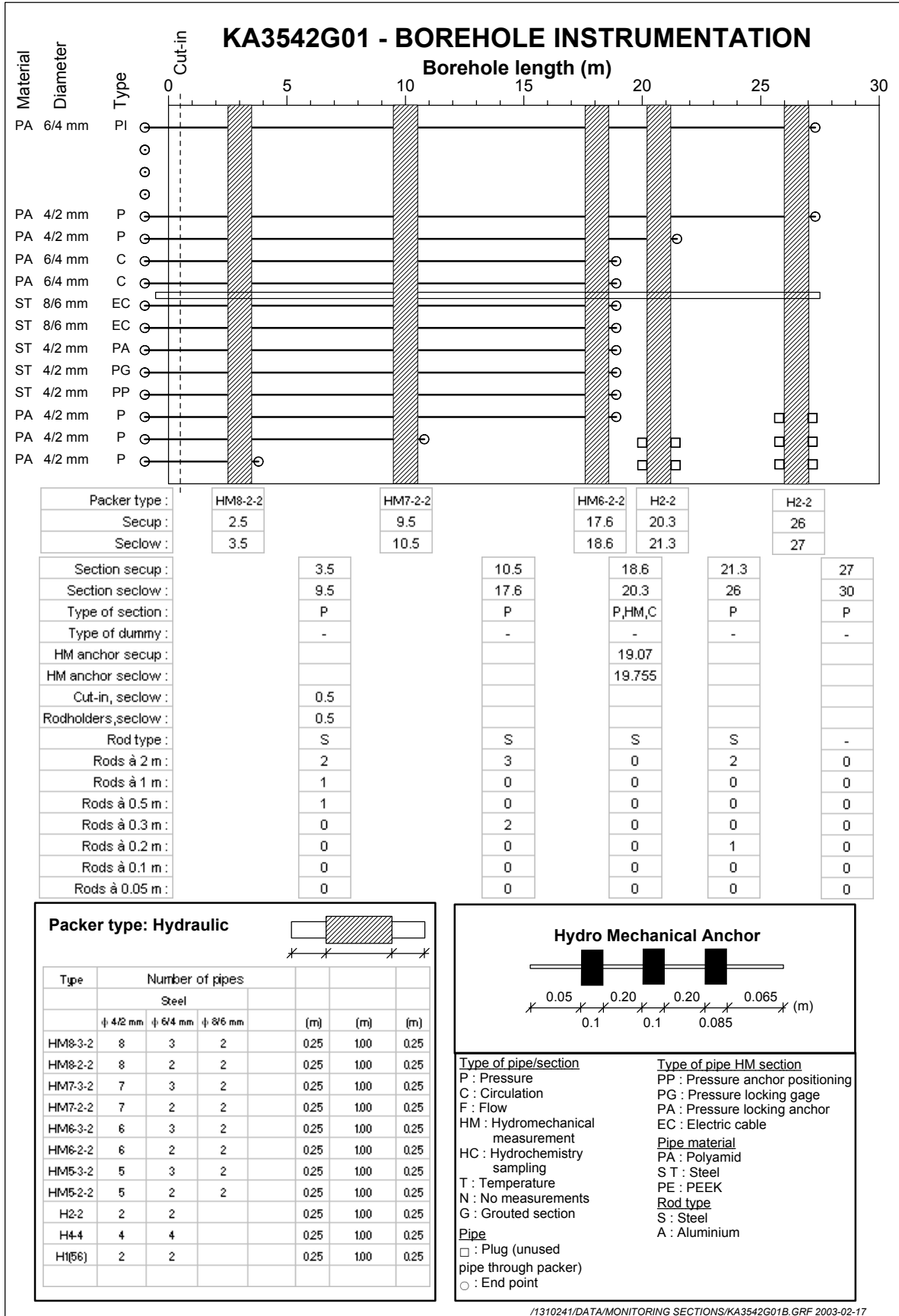
## PACKER POSITION

Borehole name: <b>KA3542G01</b>	Date design: 2003-02-17
Borehole diameter: 76 mm	Name: TFK
Borehole length: 30.01 m	Remark:
Borehole inclination: 43° down	



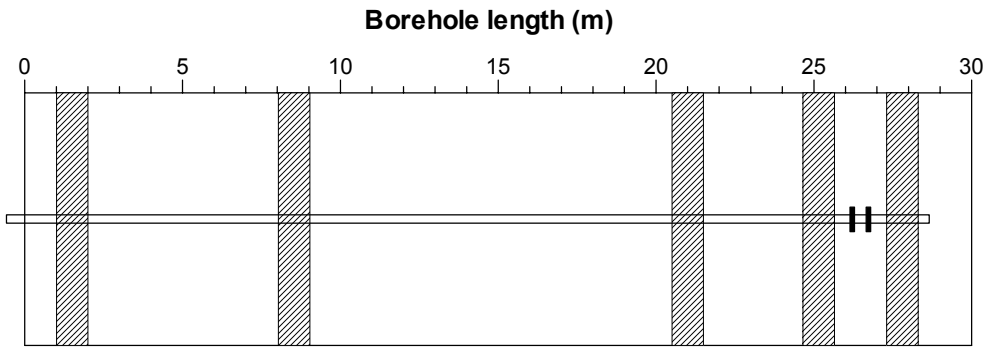
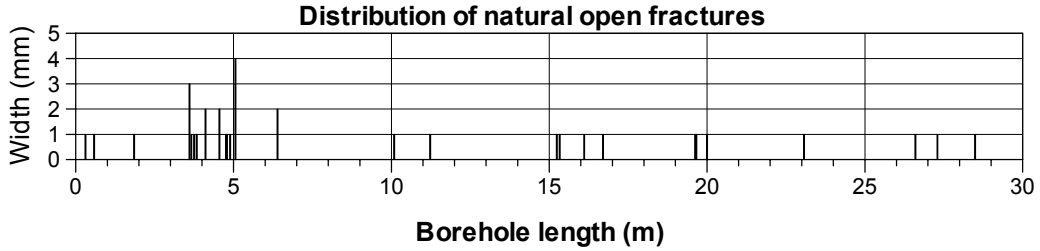
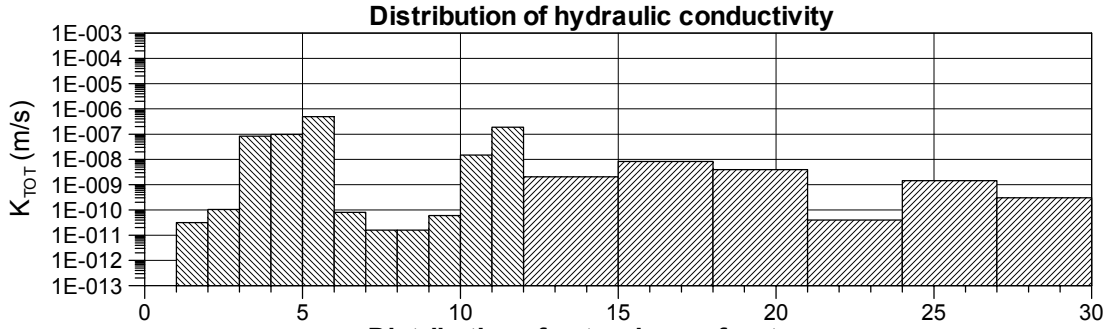
Section setup :	3.5	10.5	18.6	21.3	27
Section seclow :	9.5	17.6	20.3	26	30
Type of section :	P	P	P, HM, C	P	P
Type of dummy :	-	-	-	-	-
HM anchor setup :			19.07		
HM anchor seclow :			19.755		

<b>Type of measurement section</b>		<b>Type of dummy</b>	
P : Pressure		PE : PEEK	
C : Circulation		HD : HD1000	
F : Flow			
HM : Hydromechanical measurement		PACKER	ANCHOR
HC : Hydrochemistry sampling			
T : Temperature			
N : No measurements		DUMMY	
G : Grouted section			



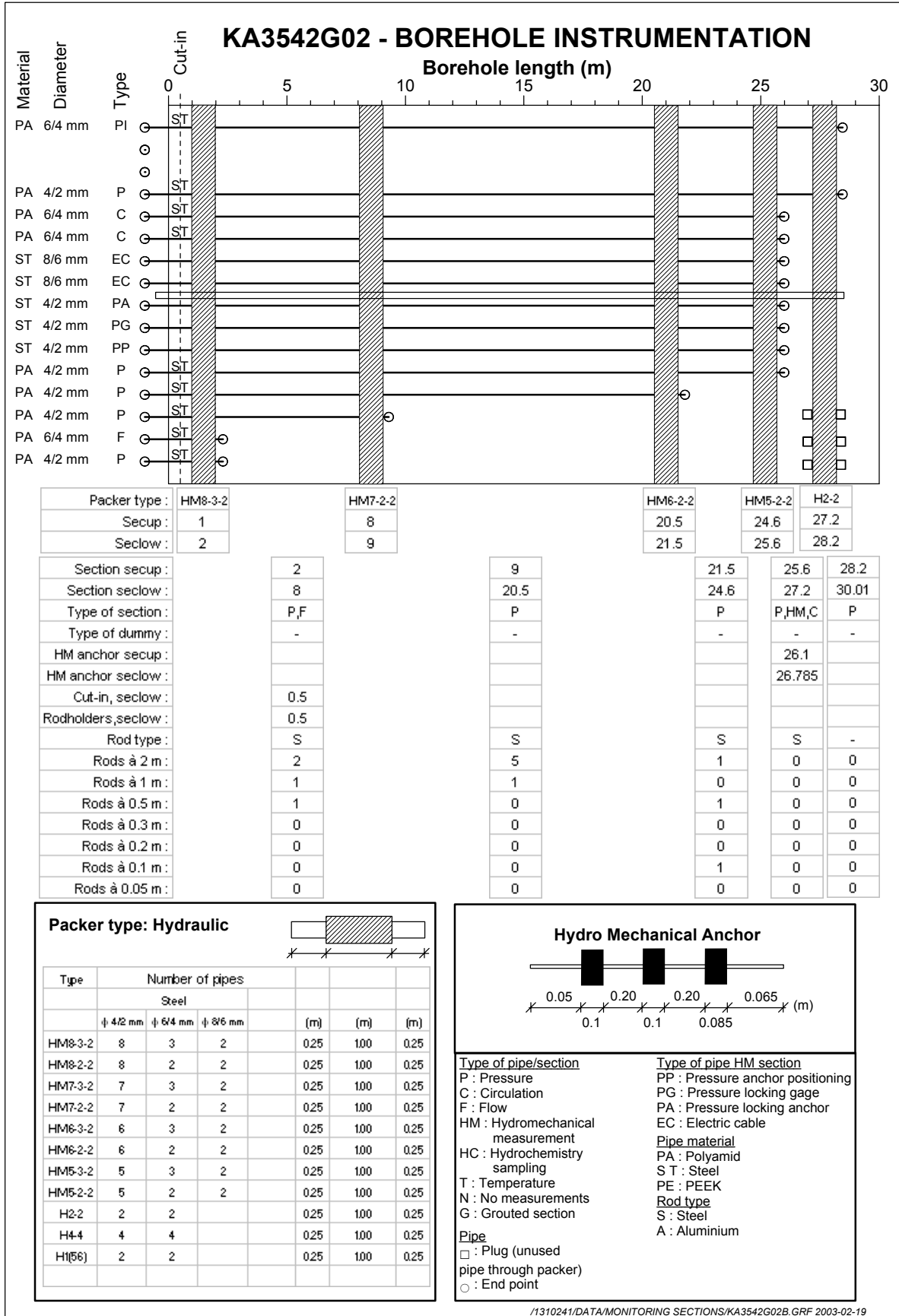
## PACKER POSITION

Borehole name: <b>KA3542G02</b>	Date design: 2003-02-20
Borehole diameter: 76 mm	Name: TFK
Borehole length: 30.01 m	Remark:
Borehole inclination: 43° down	



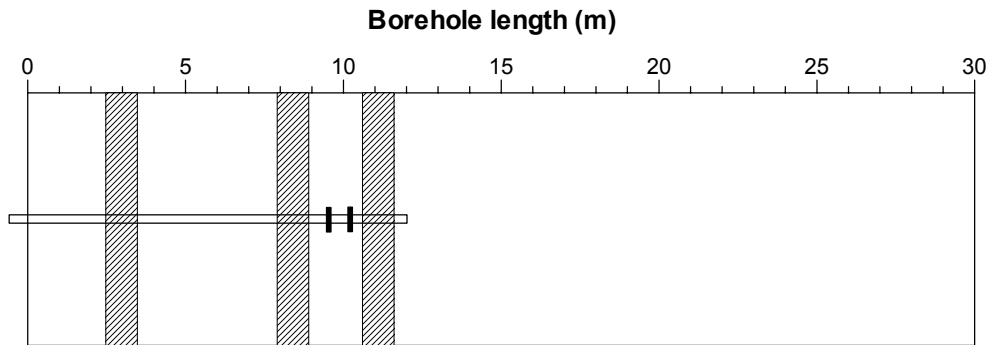
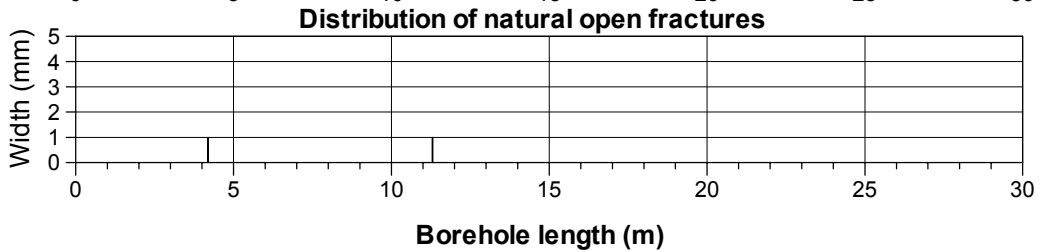
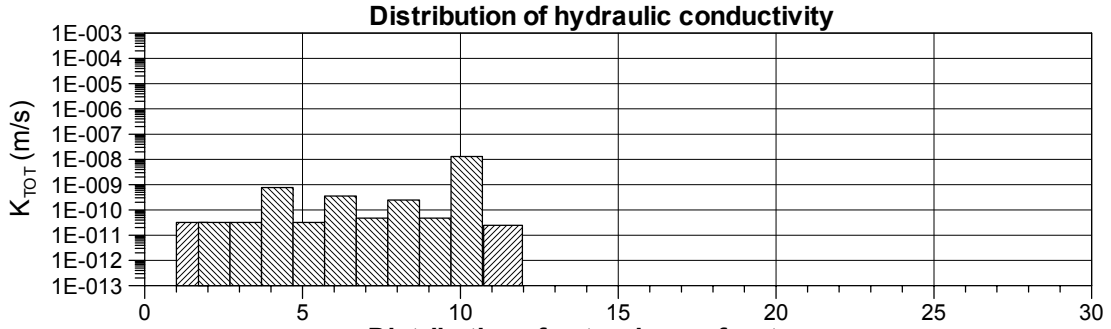
Section setup :	2	9	21.5	25.6	28.2
Section seclow :	8	20.5	24.6	27.2	30.01
Type of section :	P,F	P	P	P,H,M,C	P
Type of dummy :	-	-	-	-	-
HM anchor setup :				26.1	
HM anchor seclow :				26.785	

<b>Type of measurement section</b>		<b>Type of dummy</b>	
P : Pressure		PE : PEEK	
C : Circulation		HD : HD1000	
F : Flow			
HM : Hydromechanical measurement		PACKER	ANCHOR
HC : Hydrochemistry sampling			
T : Temperature			
N : No measurements		DUMMY	
G : Grouted section			



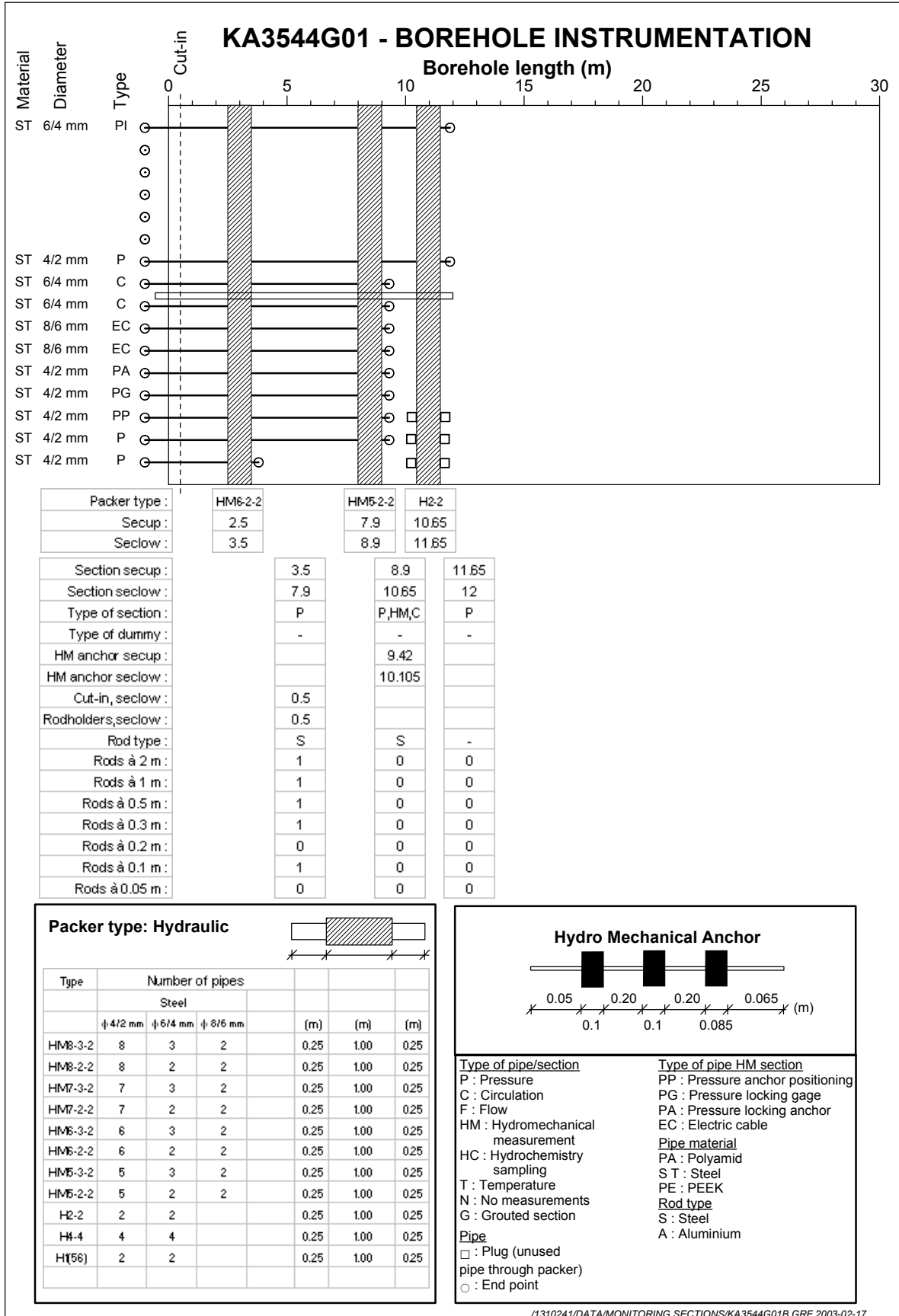
## PACKER POSITION

Borehole name: <b>KA3544G01</b>	Date design: 2003-02-17
Borehole diameter: 76 mm	Name: TFK
Borehole length: 12.00 m	Remark:
Borehole inclination: 90° down	



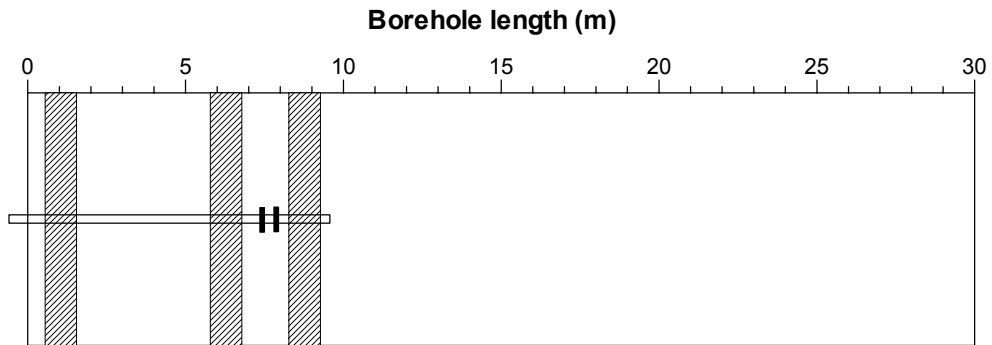
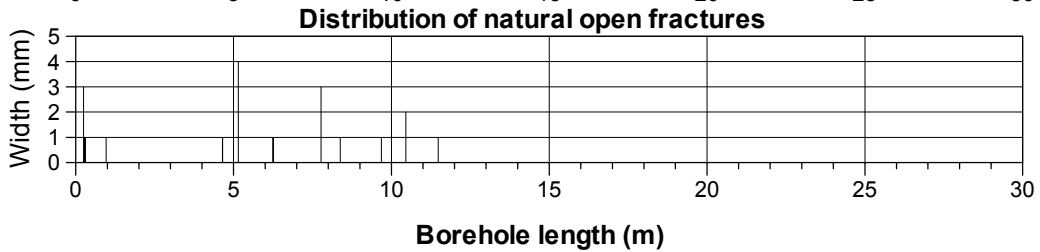
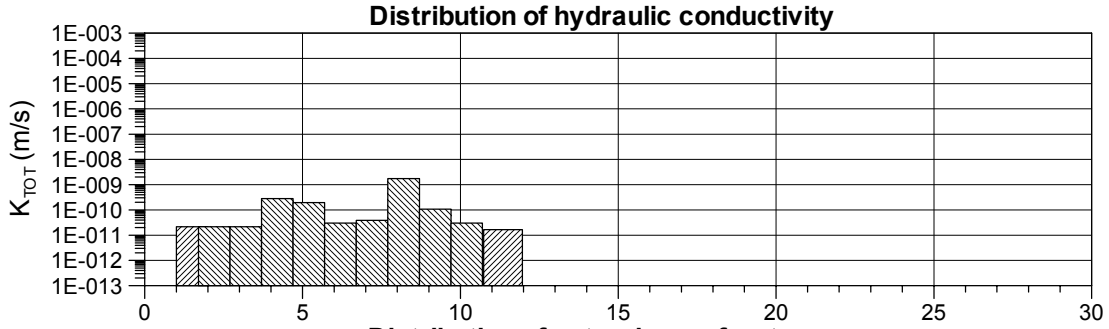
Section setup :	3.5	8.9	11.65
Section seclow :	7.9	10.65	12
Type of section :	P	P,HC	P
Type of dummy :	-	-	-
HM anchor setup :		9.42	
HM anchor seclow :		10.105	

<b>Type of measurement section</b>		<b>Type of dummy</b>	
P : Pressure		PE : PEEK	
C : Circulation		PEH : PEH	
F : Flow			
HM : Hydromechanical measurement		PACKER	ANCHOR
HC : Hydrochemistry sampling			
T : Temperature			
N : No measurements		DUMMY	
G : Grouted section			



## PACKER POSITION

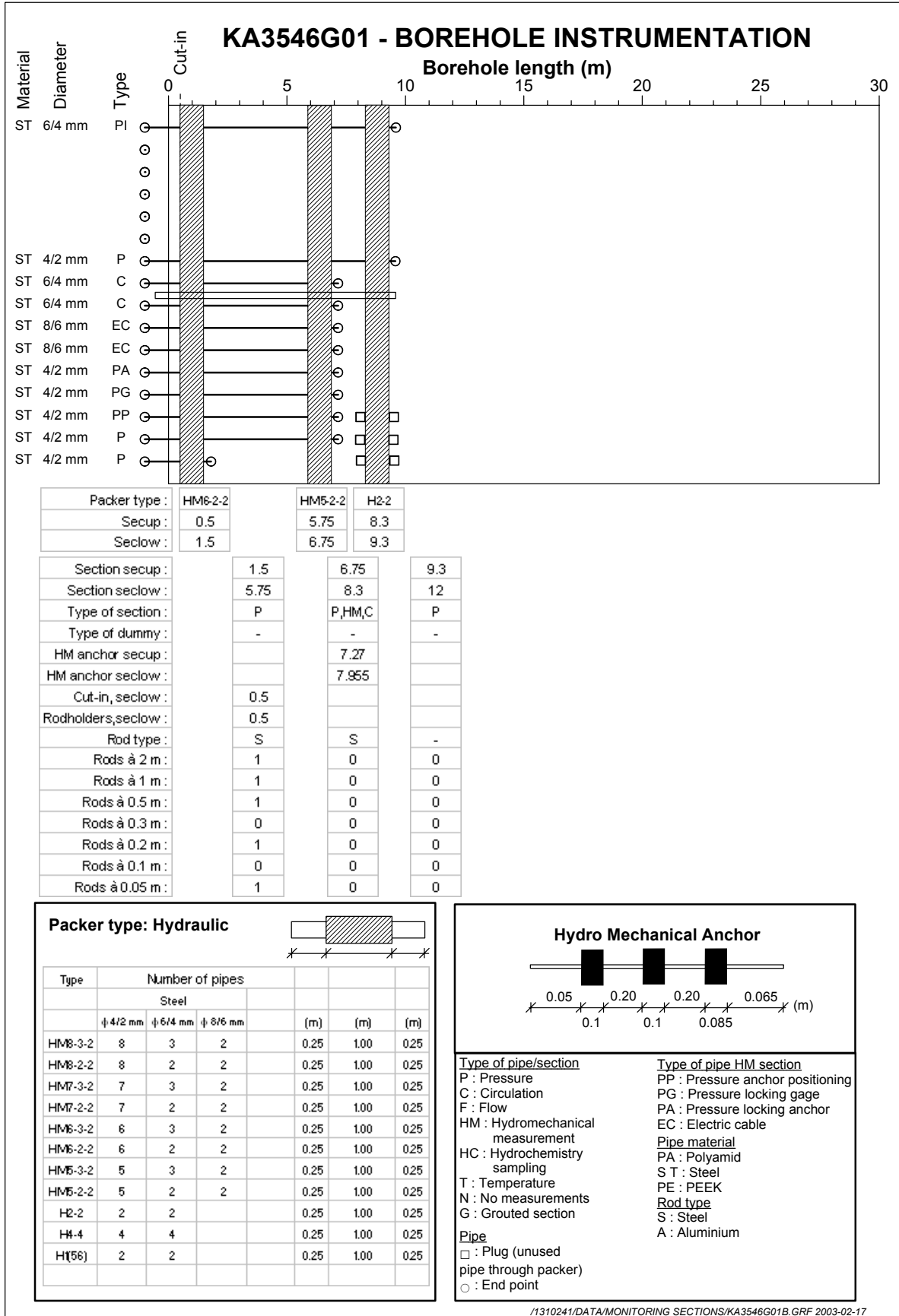
Borehole name: <b>KA3546G01</b>	Date design: 2003-02-17
Borehole diameter: 76 mm	Name: TFK
Borehole length: 12.00 m	Remark:
Borehole inclination: 90° down	



Section setup :	1.5	6.75	9.3
Section seclow :	5.75	8.3	12
Type of section :	P	P, HM, C	P
Type of dummy :	-	-	-
HM anchor setup :		7.27	
HM anchor seclow :		7.955	

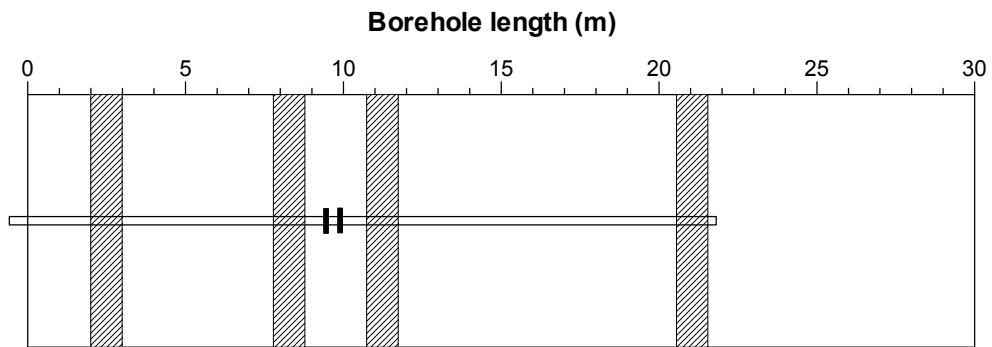
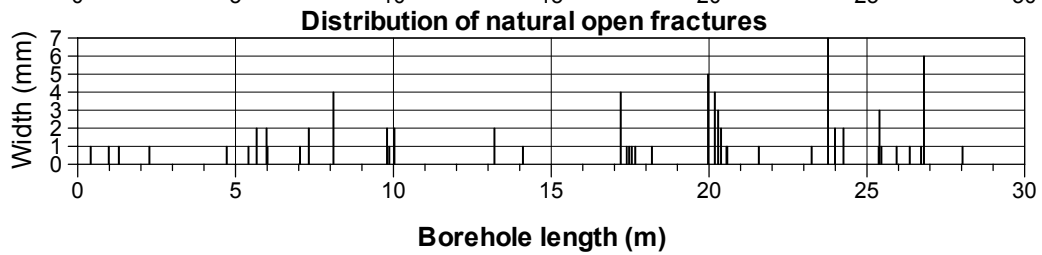
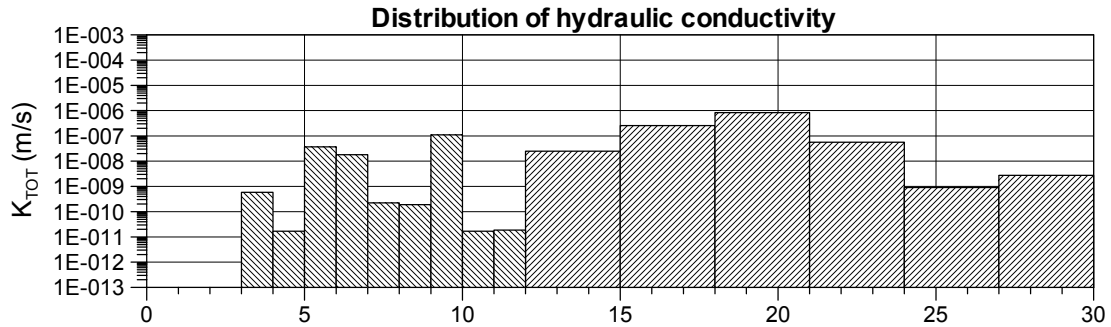
<b>Type of measurement section</b>		<b>Type of dummy</b>	
P : Pressure	C : Circulation	PE : PEEK	HD : HD1000
F : Flow	HM : Hydromechanical measurement	PACKER	ANCHOR
HC : Hydrochemistry sampling	T : Temperature	DUMMY	
N : No measurements	G : Grouted section		





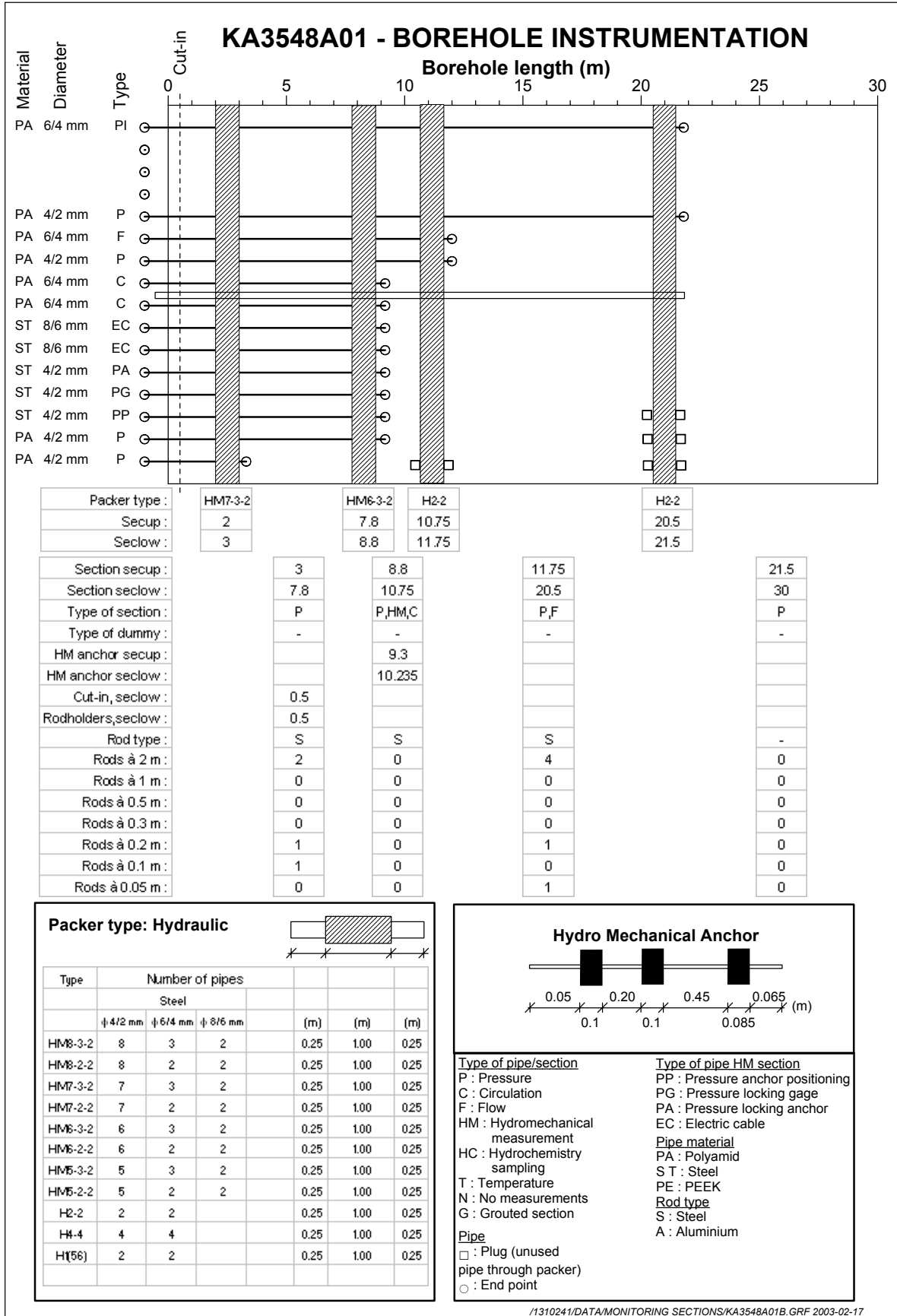
## PACKER POSITION

Borehole name: <b>KA3548A01</b>	Date design: 2003-02-17
Borehole diametre: 76 mm	Name: TFK
Borehole length: 30.00 m	Remark:
Borehole inclination: 3° down	



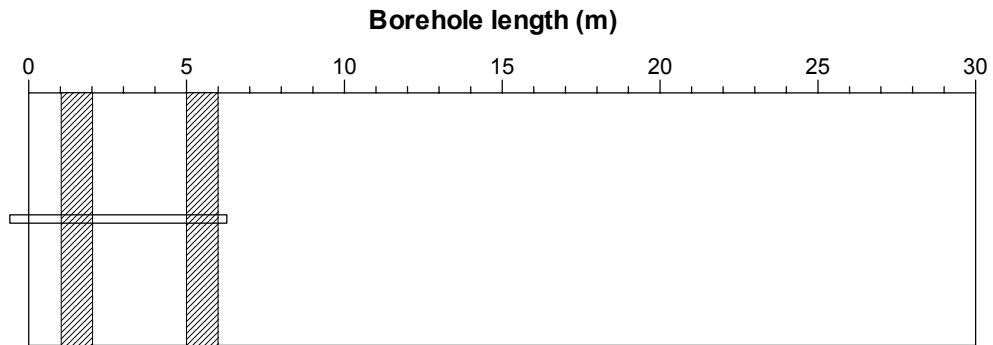
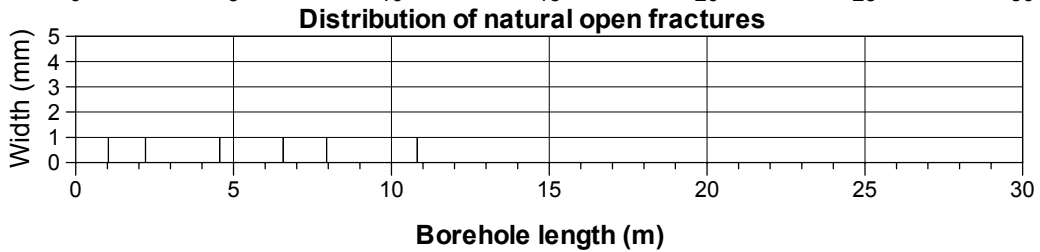
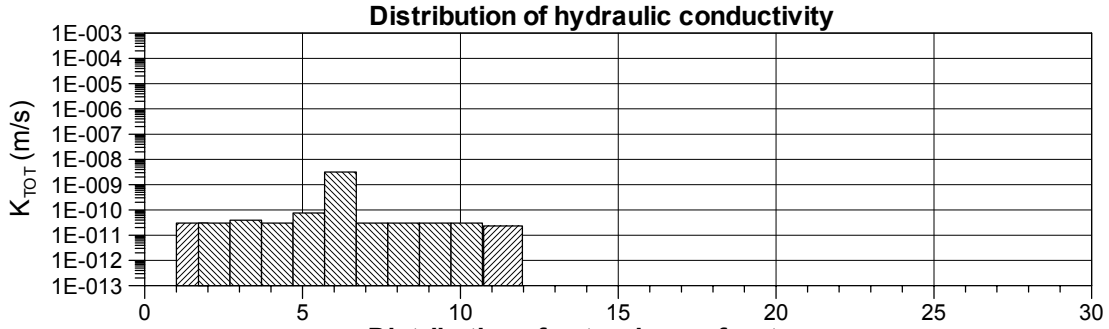
Section secup :	3	8.8	11.75	21.5
Section seclow :	7.8	10.75	20.5	30
Type of section :	P	P, HM, C	P, F	P
Type of dummy :	-	-	-	-
HM anchor secup :		9.3		
HM anchor seclow :		10.235		

<b>Type of measurement section</b>		<b>Type of dummy</b>	
P : Pressure	C : Circulation	PE : PEEK	HD : HD1000
F : Flow	HM : Hydromechanical measurement	PACKER	ANCHOR
HC : Hydrochemistry sampling	T : Temperature	DUMMY	
N : No measurements	G : Grouted section		



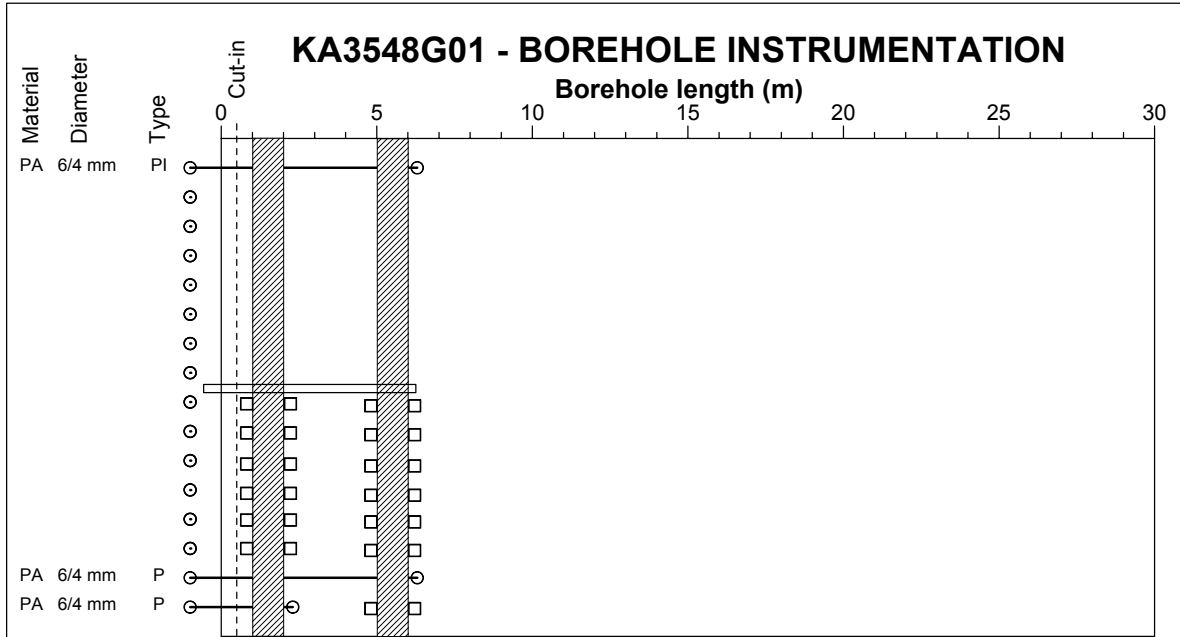
## PACKER POSITION

Borehole name: <b>KA3548G01</b>	Date design: 2003-02-17
Borehole diameter: 76 mm	Name: TFK
Borehole length: 12.00 m	Remark:
Borehole inclination: 90° down	



Section setup :	2	6
Section seclow :	5	12
Type of section :	P	P
Type of dummy :	-	-
HM anchor setup :		
HM anchor seclow :		

<b>Type of measurement section</b>		<b>Type of dummy</b>	
P : Pressure		PE : PEEK	
C : Circulation		PEH : PEH	
F : Flow			
HM : Hydromechanical measurement		PACKER	ANCHOR
HC : Hydrochemistry sampling			
T : Temperature			
N : No measurements		DUMMY	
G : Grouted section			



Packer type :	H44	H44
Secup :	1	5
Seclow :	2	6
Section secup :	2	6
Section seclow :	5	12
Type of section :	P	P
Type of dummy :	-	-
HM anchor secup :		
HM anchor seclow :		
Cut-in, seclow :	0.5	
Rodholders, seclow :	0.5	
Rod type :	S	-
Rods à 2 m :	1	0
Rods à 1 m :	0	0
Rods à 0.5 m :	1	0
Rods à 0.3 m :	0	0
Rods à 0.2 m :	0	0
Rods à 0.1 m :	0	0
Rods à 0.05 m :	0	0

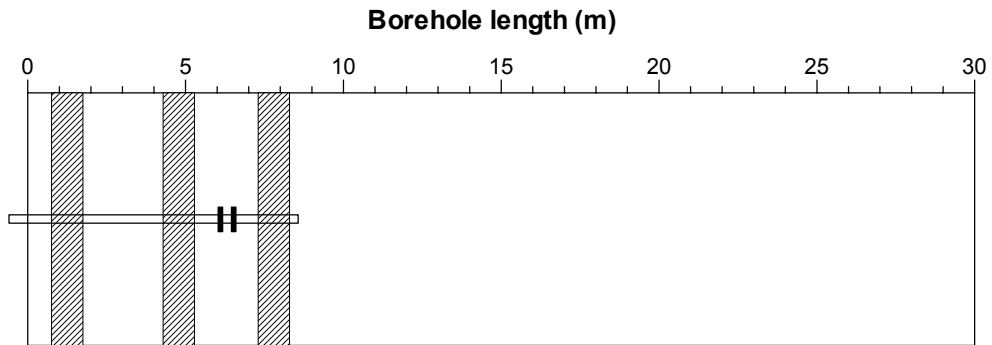
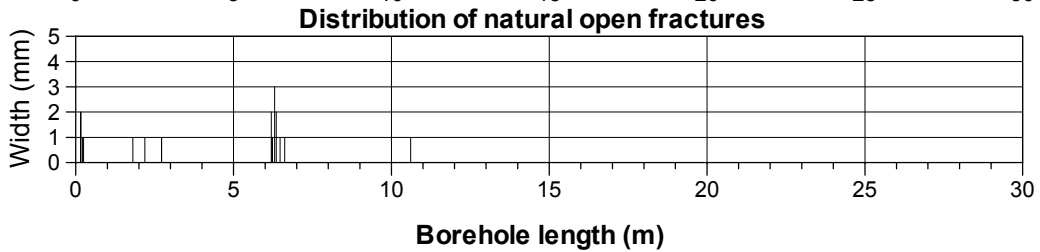
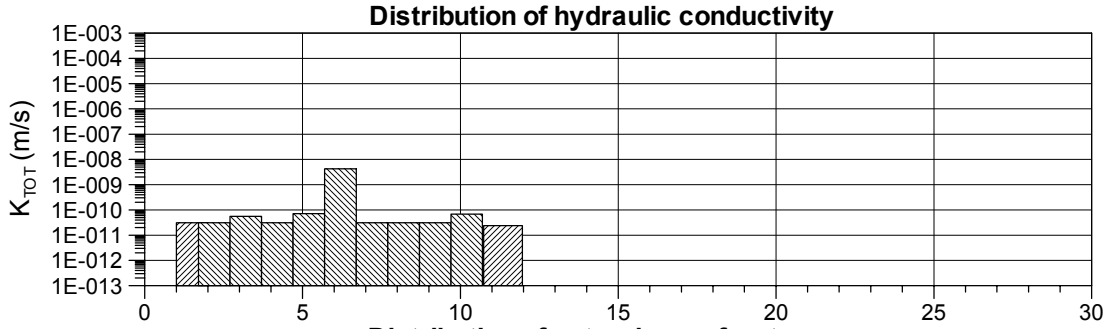
**Packer type: Hydraulic**

Type	Number of pipes			(m)	(m)	(m)
	Steel					
	∅ 4/2 mm	∅ 6/4 mm	∅ 8/6 mm			
HM8-3-2	8	3	2	0.25	1.00	0.25
HM8-2-2	8	2	2	0.25	1.00	0.25
HM7-3-2	7	3	2	0.25	1.00	0.25
HM7-2-2	7	2	2	0.25	1.00	0.25
HM6-3-2	6	3	2	0.25	1.00	0.25
HM6-2-2	6	2	2	0.25	1.00	0.25
HM5-3-2	5	3	2	0.25	1.00	0.25
HM5-2-2	5	2	2	0.25	1.00	0.25
H2-2	2	2		0.25	1.00	0.25
H4-4	4	4		0.25	1.00	0.25
H(56)	2	2		0.25	1.00	0.25

<b>Type of pipe/section</b>	<b>Type of pipe HM section</b>
P : Pressure	PP : Pressure anchor positioning
C : Circulation	PG : Pressure locking gage
F : Flow	PA : Pressure locking anchor
HM : Hydromechanical measurement	EC : Electric cable
HC : Hydrochemistry sampling	<b>Pipe material</b>
T : Temperature	PA : Polyamid
N : No measurements	ST : Steel
G : Grouted section	PE : PEEK
<b>Pipe</b>	<b>Rod type</b>
□ : Plug (unused pipe through packer)	S : Steel
○ : End point	A : Aluminium

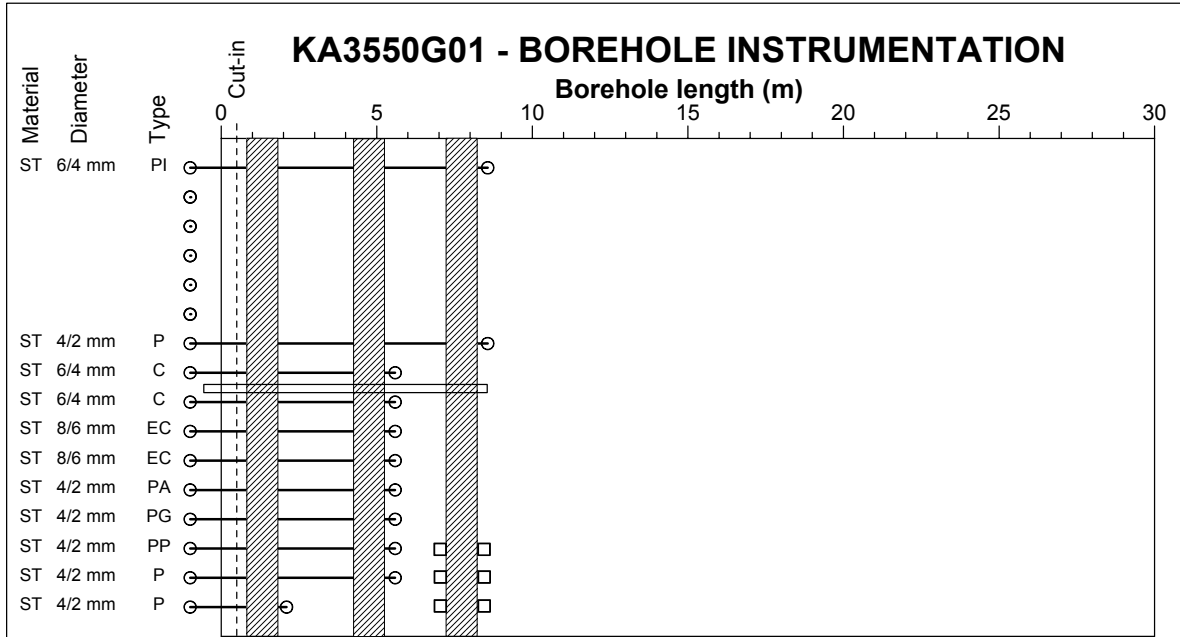
## PACKER POSITION

Borehole name: <b>KA3550G01</b>	Date design: 2003-02-17
Borehole diametre: 76 mm	Name: TFK
Borehole length: 12.03 m	Remark:
Borehole inclination: 90° down	



Section setup :	1.8	5.2	8.3
Section seclow :	4.2	7.3	12.03
Type of section :	P	P, HM, C	P
Type of dummy :	-	-	-
HM anchor setup :		5.7	
HM anchor seclow :		6.785	

<b>Type of measurement section</b>		<b>Type of dummy</b>	
P : Pressure		PE : PEEK	
C : Circulation		PEH : PEH	
F : Flow			
HM : Hydromechanical measurement		PACKER	ANCHOR
HC : Hydrochemistry sampling			
T : Temperature			
N : No measurements		DUMMY	
G : Grouted section			



Packer type :	HM6-2-2	HM5-2-2	H2-2
Secup :	0.8	4.2	7.3
Seclow :	1.8	5.2	8.3
Section secup :	1.8	5.2	8.3
Section seclow :	4.2	7.3	12.03
Type of section :	P	P, HM, C	P
Type of dummy :	-	-	-
HM anchor secup :		5.7	
HM anchor seclow :		6.785	
Cut-in, seclow :	0.5		
Rodholders, seclow :	0.5		
Rod type :	S	S	-
Rods à 2 m :	0	0	0
Rods à 1 m :	1	1	0
Rods à 0.5 m :	1	1	0
Rods à 0.3 m :	0	0	0
Rods à 0.2 m :	2	0	0
Rods à 0.1 m :	0	1	0
Rods à 0.05 m :	0	0	0

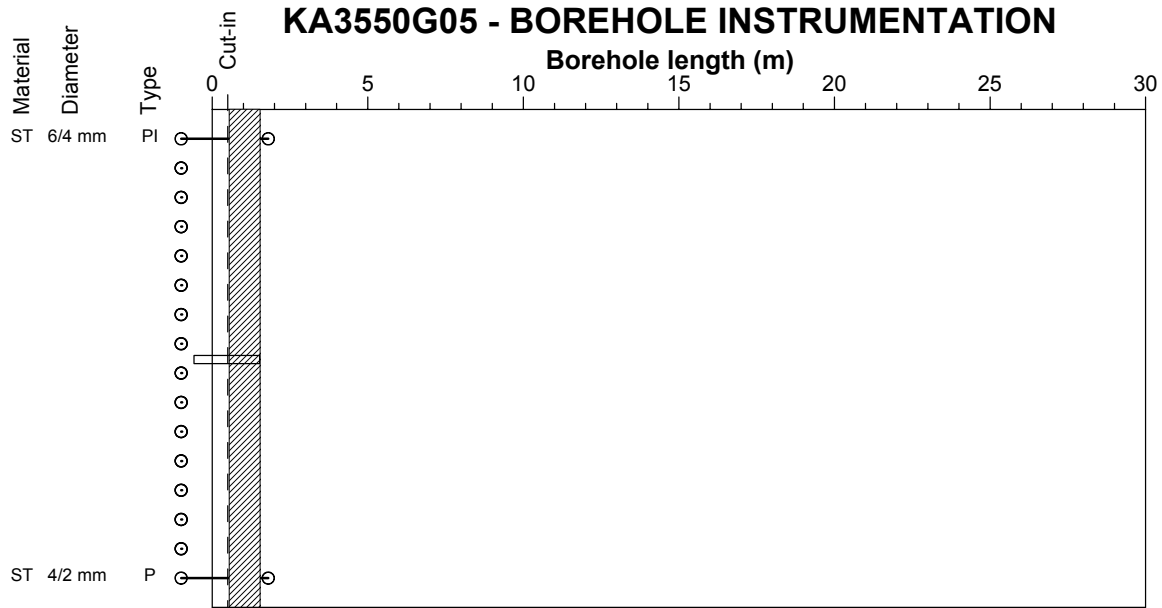
**Packer type: Hydraulic**

Type	Number of pipes			(m)	(m)	(m)
	Steel					
	∅ 4/2 mm	∅ 6/4 mm	∅ 8/6 mm			
HM8-3-2	8	3	2	0.25	1.00	0.25
HM8-2-2	8	2	2	0.25	1.00	0.25
HM7-3-2	7	3	2	0.25	1.00	0.25
HM7-2-2	7	2	2	0.25	1.00	0.25
HM6-3-2	6	3	2	0.25	1.00	0.25
HM6-2-2	6	2	2	0.25	1.00	0.25
HM5-3-2	5	3	2	0.25	1.00	0.25
HM5-2-2	5	2	2	0.25	1.00	0.25
H2-2	2	2		0.25	1.00	0.25
H4-4	4	4		0.25	1.00	0.25
H(56)	2	2		0.25	1.00	0.25

#### Hydro Mechanical Anchor

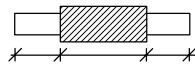
Type of pipe/section	Type of pipe HM section
P : Pressure	PP : Pressure anchor positioning
C : Circulation	PG : Pressure locking gage
F : Flow	PA : Pressure locking anchor
HM : Hydromechanical measurement	EC : Electric cable
HC : Hydrochemistry sampling	<u>Pipe material</u>
T : Temperature	PA : Polyamid
N : No measurements	ST : Steel
G : Grouted section	PE : PEEK
<u>Pipe</u>	<u>Rod type</u>
□ : Plug (unused pipe through packer)	S : Steel
○ : End point	A : Aluminium

## KA3550G05 - BOREHOLE INSTRUMENTATION



Packer type :	H(56)
Secup :	0.5
Seclow :	1.5
Section secup :	1.5
Section seclow :	3
Type of section :	P
Type of dummy :	-
HM anchor secup :	
HM anchor seclow :	
Cut-in, seclow :	0.5
Rodholders, seclow :	0.5
Rod type :	-
Rods à 2 m :	0
Rods à 1 m :	0
Rods à 0.5 m :	0
Rods à 0.3 m :	0
Rods à 0.2 m :	0
Rods à 0.1 m :	0
Rods à 0.05 m :	0

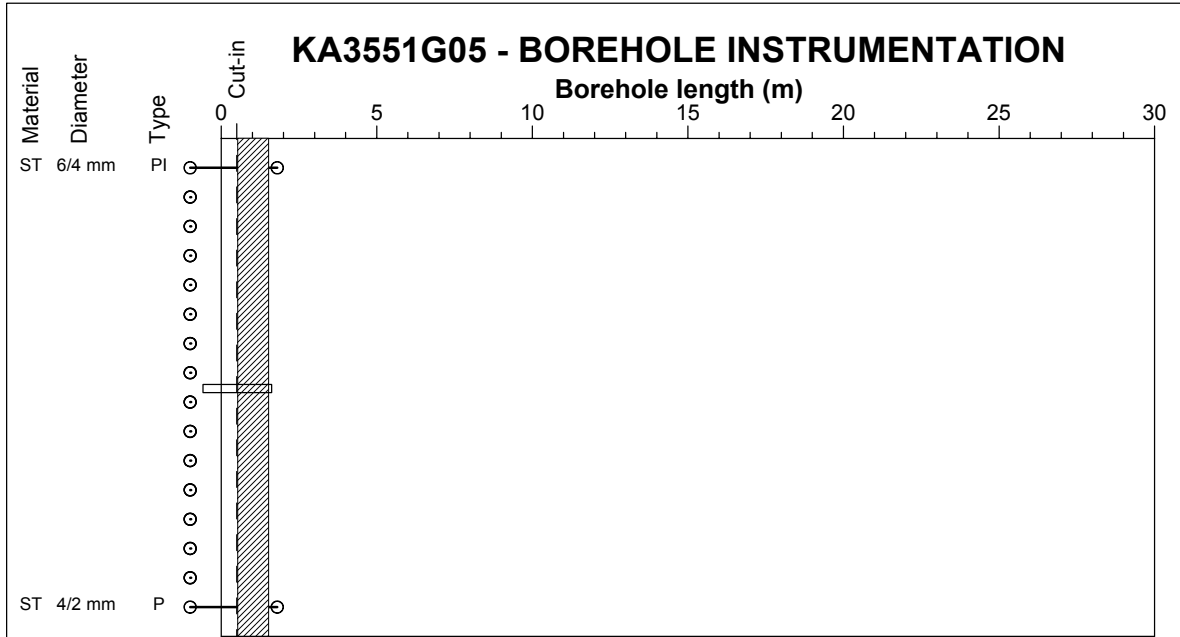
**Packer type: Hydraulic**



Type	Number of pipes			(m)	(m)	(m)
	Steel					
	∅ 4/2 mm	∅ 6/4 mm	∅ 8/6 mm			
HM8-3-2	8	3	2	0.25	1.00	0.25
HM8-2-2	8	2	2	0.25	1.00	0.25
HM7-3-2	7	3	2	0.25	1.00	0.25
HM7-2-2	7	2	2	0.25	1.00	0.25
HM6-3-2	6	3	2	0.25	1.00	0.25
HM6-2-2	6	2	2	0.25	1.00	0.25
HM5-3-2	5	3	2	0.25	1.00	0.25
HM5-2-2	5	2	2	0.25	1.00	0.25
H2-2	2	2		0.25	1.00	0.25
H4-4	4	4		0.25	1.00	0.25
H(56)	2	2		0.25	1.00	0.25

<u>Type of pipe/section</u>	<u>Type of pipe HM section</u>
P : Pressure	PP : Pressure anchor positioning
C : Circulation	PG : Pressure locking gage
F : Flow	PA : Pressure locking anchor
HM : Hydromechanical measurement	EC : Electric cable
HC : Hydrochemistry sampling	<u>Pipe material</u>
T : Temperature	PA : Polyamid
N : No measurements	ST : Steel
G : Grouted section	PE : PEEK
<u>Pipe</u>	<u>Rod type</u>
□ : Plug (unused pipe through packer)	S : Steel
○ : End point	A : Aluminium





Packer type :	H(56)
Secup :	0.5
Seclow :	1.5
Section secup :	1.5
Section seclow :	3.1
Type of section :	P
Type of dummy :	-
HM anchor secup :	
HM anchor seclow :	
Cut-in, seclow :	0.5
Rodholders, seclow :	0.5
Rod type :	-
Rods à 2 m :	0
Rods à 1 m :	0
Rods à 0.5 m :	0
Rods à 0.3 m :	0
Rods à 0.2 m :	0
Rods à 0.1 m :	0
Rods à 0.05 m :	0

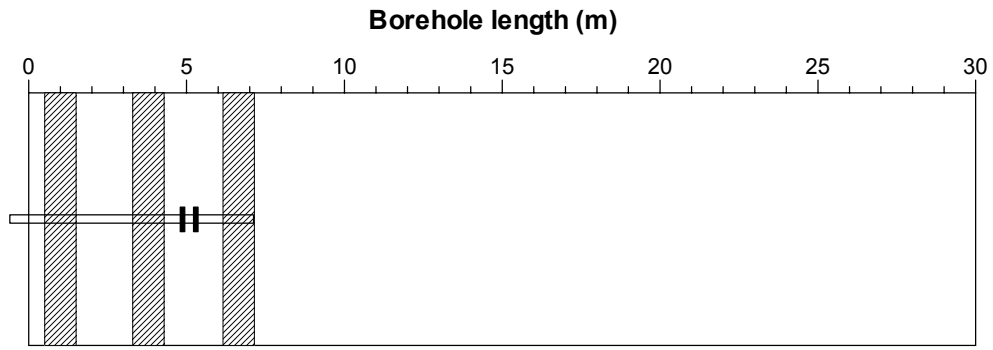
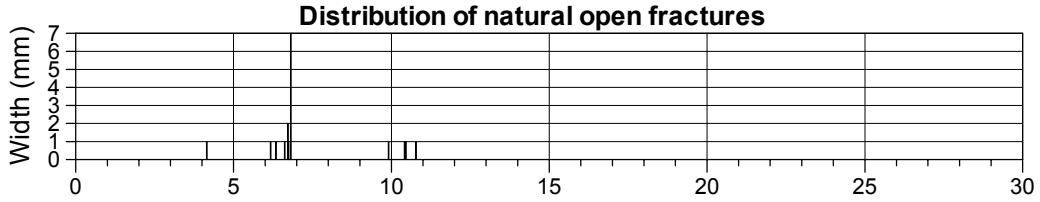
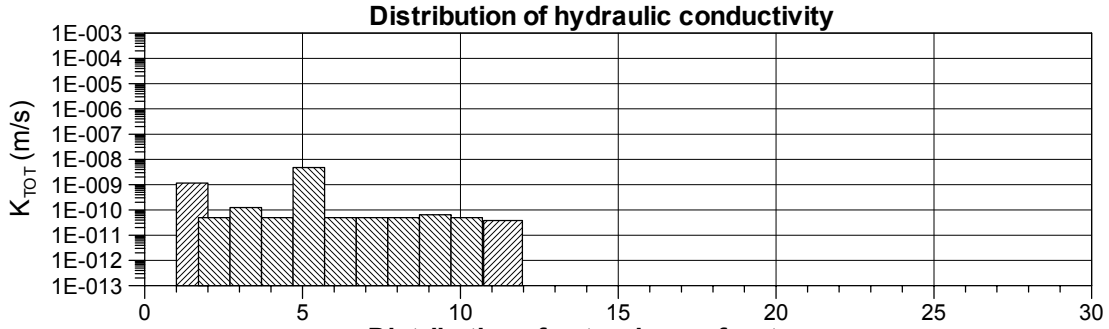
**Packer type: Hydraulic**

Type	Number of pipes			(m)	(m)	(m)
	Steel					
	∅ 4/2 mm	∅ 6/4 mm	∅ 8/6 mm			
HM8-3-2	8	3	2	0.25	1.00	0.25
HM8-2-2	8	2	2	0.25	1.00	0.25
HM7-3-2	7	3	2	0.25	1.00	0.25
HM7-2-2	7	2	2	0.25	1.00	0.25
HM6-3-2	6	3	2	0.25	1.00	0.25
HM6-2-2	6	2	2	0.25	1.00	0.25
HM5-3-2	5	3	2	0.25	1.00	0.25
HM5-2-2	5	2	2	0.25	1.00	0.25
H2-2	2	2		0.25	1.00	0.25
H4-4	4	4		0.25	1.00	0.25
H(56)	2	2		0.25	1.00	0.25

<u>Type of pipe/section</u>	<u>Type of pipe HM section</u>
P : Pressure	PP : Pressure anchor positioning
C : Circulation	PG : Pressure locking gage
F : Flow	PA : Pressure locking anchor
HM : Hydromechanical measurement	EC : Electric cable
HC : Hydrochemistry sampling	<u>Pipe material</u>
T : Temperature	PA : Polyamid
N : No measurements	ST : Steel
G : Grouted section	PE : PEEK
<u>Pipe</u>	<u>Rod type</u>
□ : Plug (unused pipe through packer)	S : Steel
○ : End point	A : Aluminium

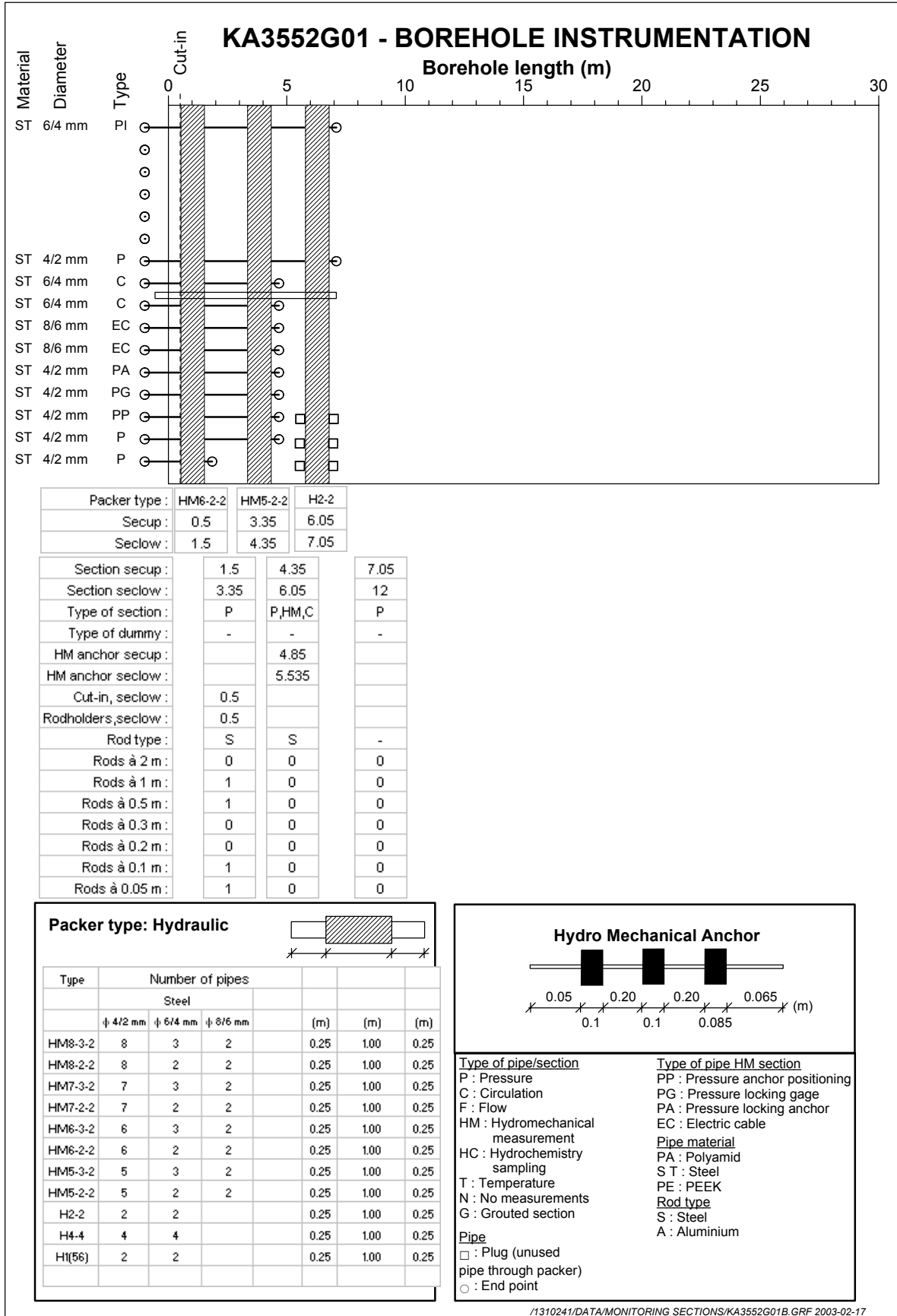
## PACKER POSITION

Borehole name: <b>KA3552G01</b>	Date design: 2003-02-17
Borehole diameter: 76 mm	Name: TFK
Borehole length: 12.01 m	Remark:
Borehole inclination: 90° down	



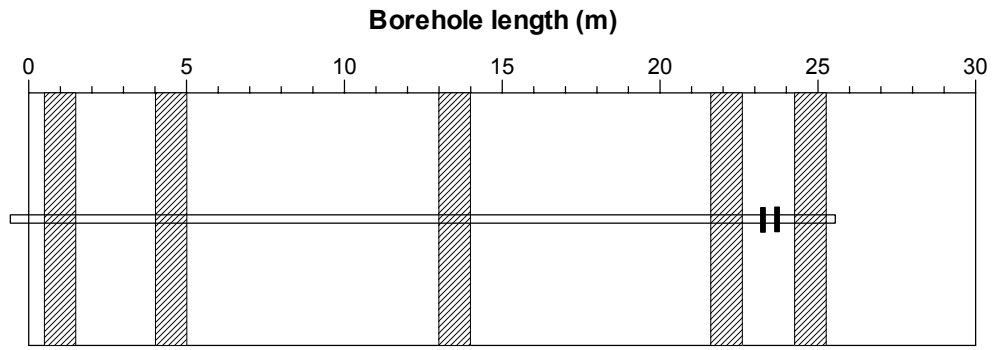
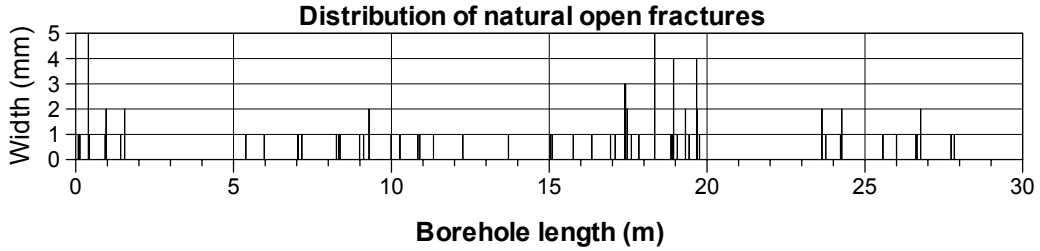
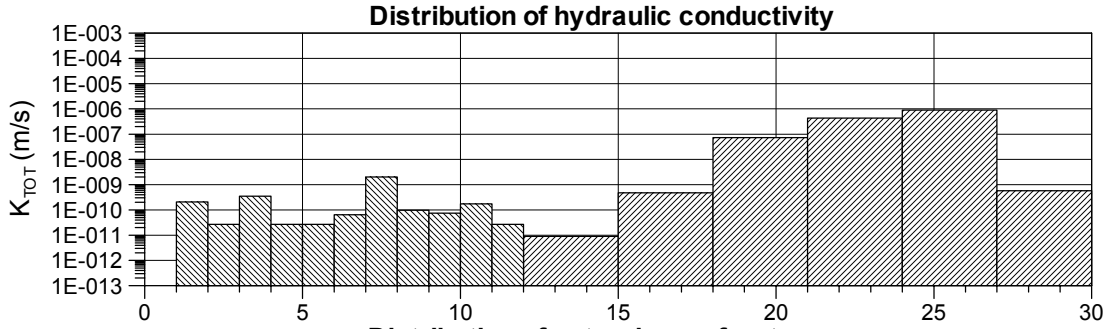
Section setup :	1.5	4.35	7.05
Section seclow :	3.35	6.05	12
Type of section :	P	P, HM, C	P
Type of dummy :	-	-	-
HM anchor setup :		4.85	
HM anchor seclow :		5.535	

<b>Type of measurement section</b>		<b>Type of dummy</b>	
P : Pressure	C : Circulation	PE : PEEK	HD : HD1000
F : Flow	HM : Hydromechanical measurement	PACKER	ANCHOR
HC : Hydrochemistry sampling	T : Temperature	DUMMY	
N : No measurements	G : Grouted section		



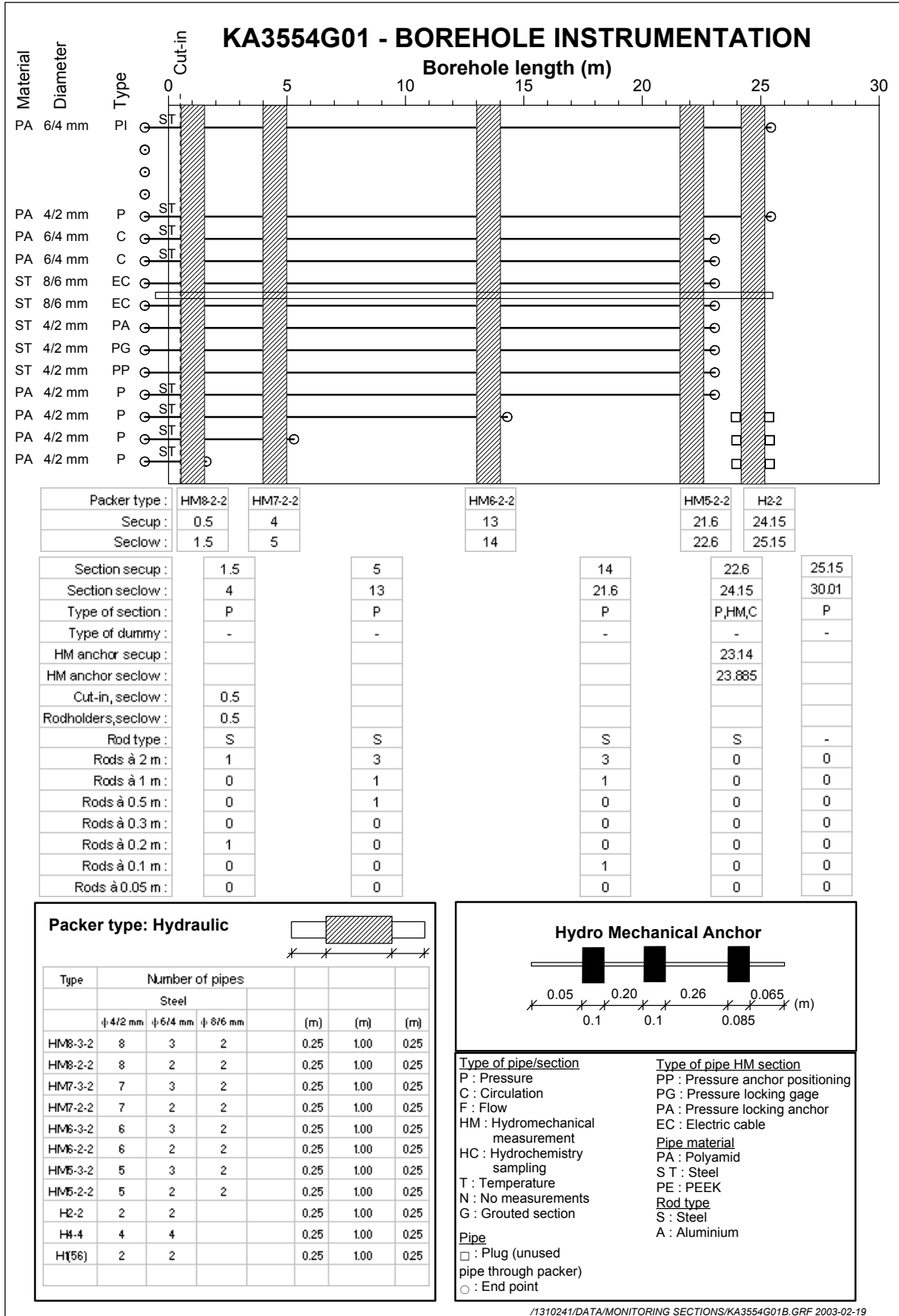
## PACKER POSITION

Borehole name: <b>KA3554G01</b>	Date design: 2003-02-17
Borehole diameter: 76 mm	Name: TFK
Borehole length: 30.01 m	Remark:
Borehole inclination: 45° down	



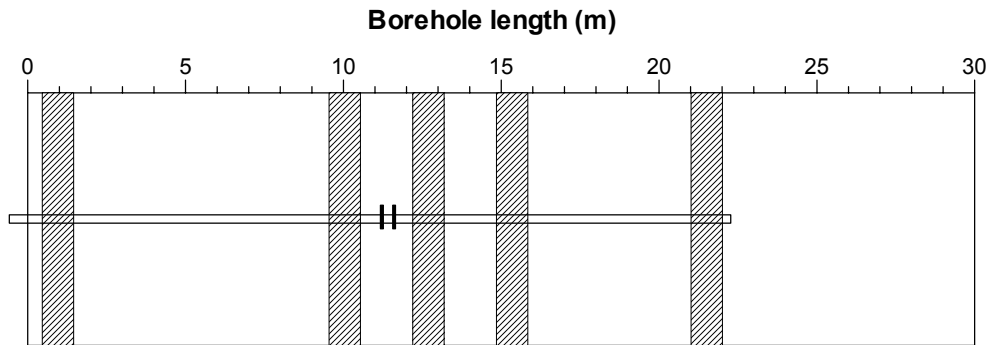
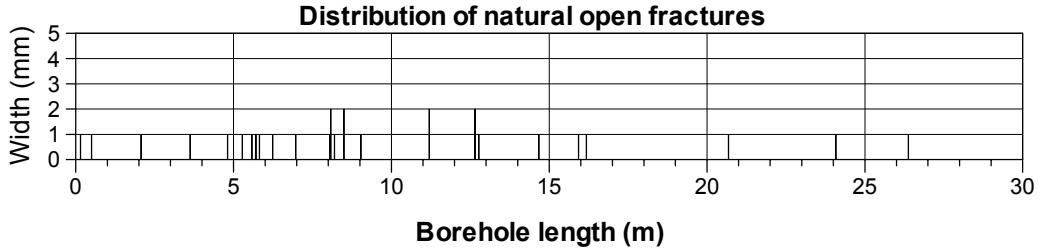
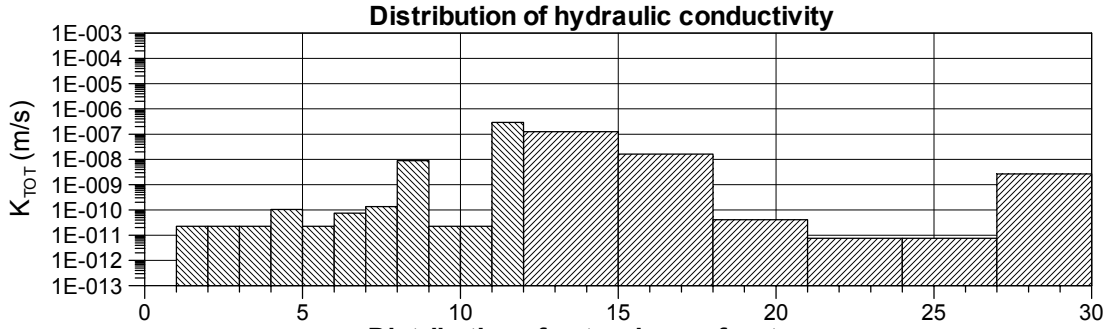
Section setup :	1.5	5	14	22.6	25.15
Section seclow :	4	13	21.6	24.15	30.01
Type of section :	P	P	P	P, HM, C	P
Type of dummy :	-	-	-	-	-
HM anchor setup :				23.14	
HM anchor seclow :				23.885	

<b>Type of measurement section</b>		<b>Type of dummy</b>	
P : Pressure	C : Circulation	PE : PEEK	HD : HD1000
F : Flow	HM : Hydromechanical measurement	PACKER	ANCHOR
HC : Hydrochemistry sampling	T : Temperature	DUMMY	
N : No measurements	G : Grouted section		



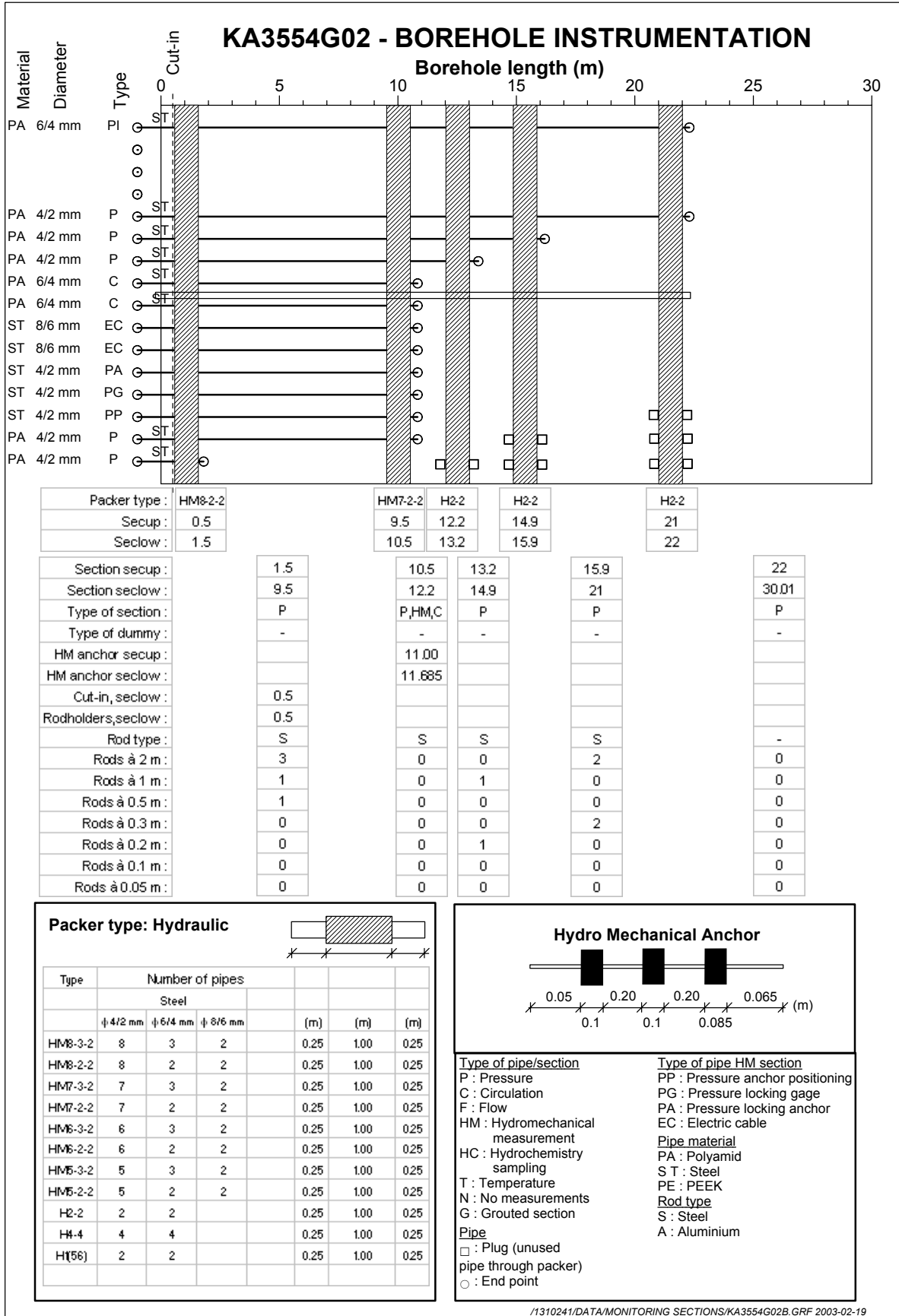
## PACKER POSITION

Borehole name: <b>KA3554G02</b>	Date design: 2003-02-17
Borehole diameter: 76 mm	Name: TFK
Borehole length: 30.01 m	Remark:
Borehole inclination: 45° down	



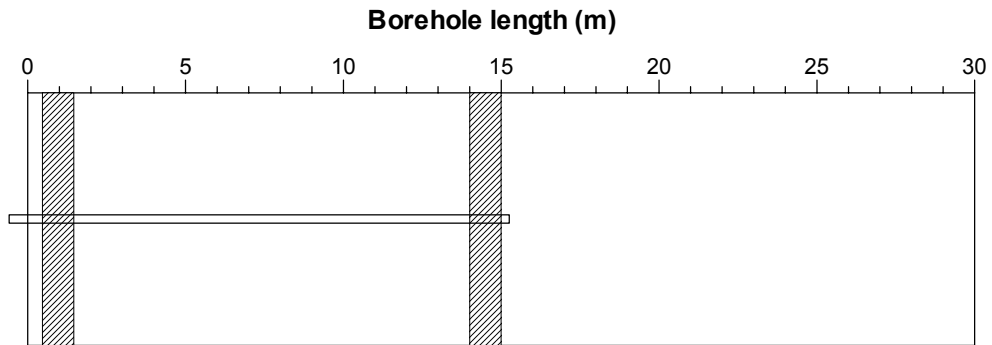
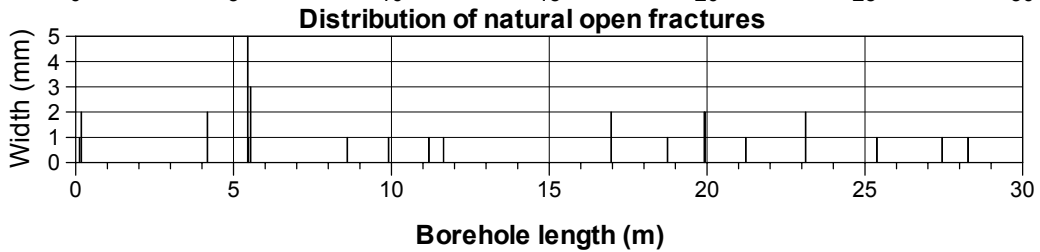
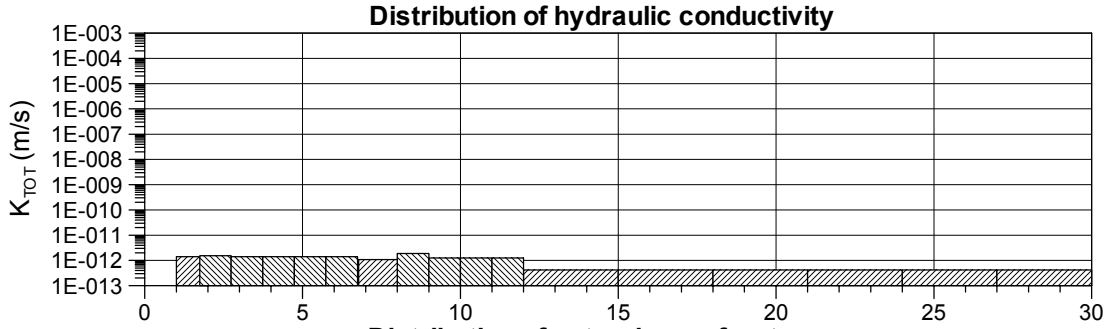
Section setup :	1.5	10.5	13.2	15.9	22
Section seclow :	9.5	12.2	14.9	21	30.01
Type of section :	P	P, HM, C	P	P	P
Type of dummy :	-	-	-	-	-
HM anchor setup :		11.00			
HM anchor seclow :		11.685			

<b>Type of measurement section</b>		<b>Type of dummy</b>	
P : Pressure	C : Circulation	PE : PEEK	HD : HD1000
F : Flow	HM : Hydromechanical measurement	PACKER              ANCHOR	DUMMY
HC : Hydrochemistry sampling	T : Temperature		
N : No measurements	G : Grouted section		



## PACKER POSITION

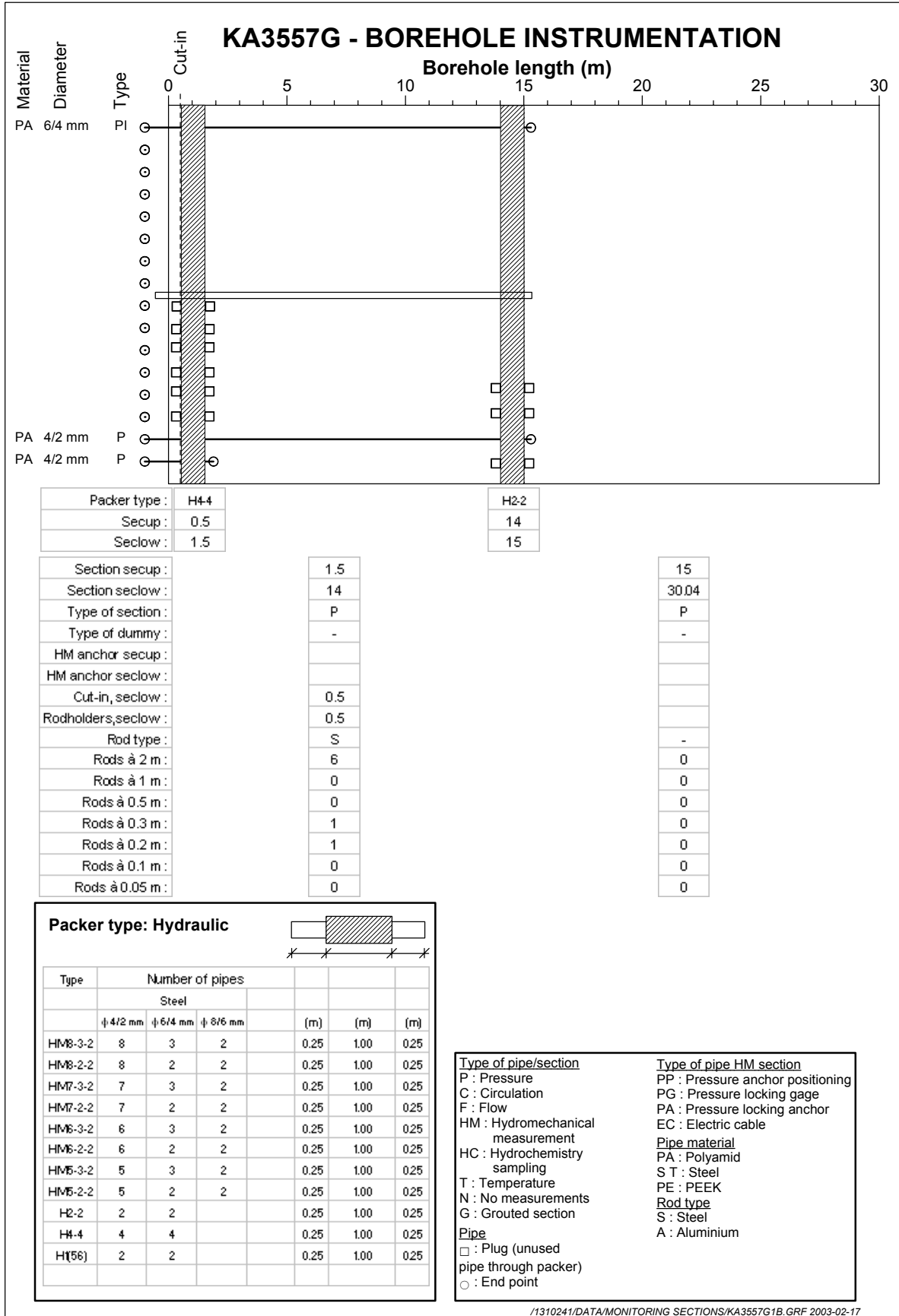
Borehole name: <b>KA3557G</b>	Date design: 2003-02-17
Borehole diametre: 76 mm	Name: TFK
Borehole length: 30.04 m	Remark:
Borehole inclination: 81° down	



Section setup :	1.5	15
Section seclow :	14	30.04
Type of section :	P	P
Type of dummy :	-	-
HM anchor setup :		
HM anchor seclow :		

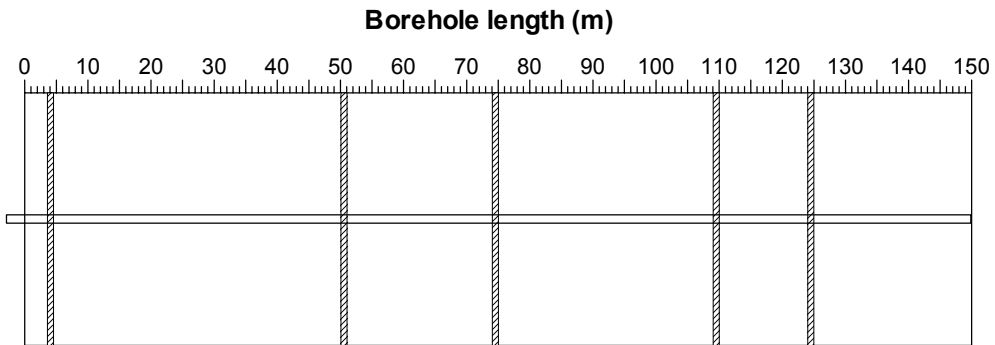
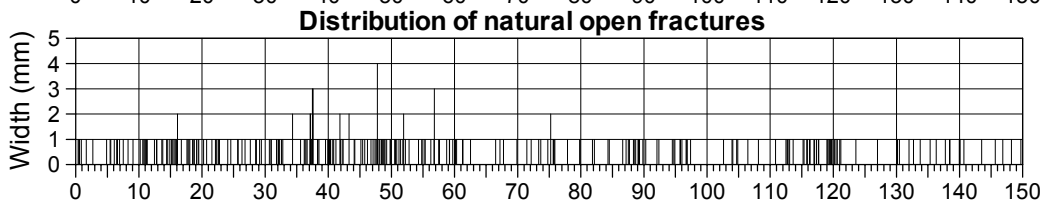
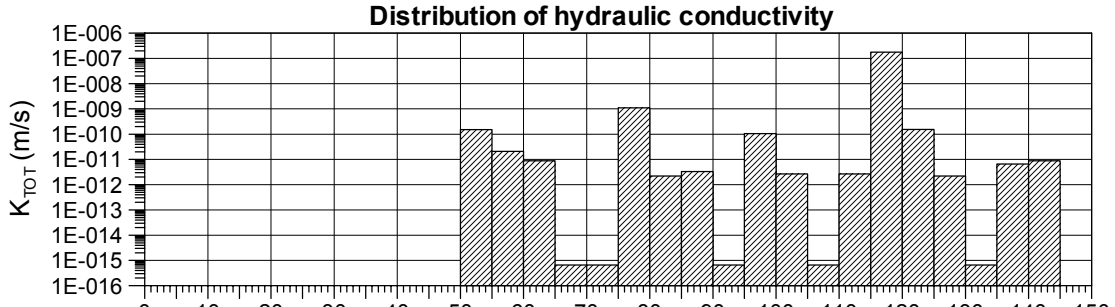
<b>Type of measurement section</b>		<b>Type of dummy</b>	
P : Pressure		PE : PEEK	
C : Circulation		HD : HD1000	
F : Flow			
HM : Hydromechanical measurement		PACKER	ANCHOR
HC : Hydrochemistry sampling			
T : Temperature			
N : No measurements		DUMMY	
G : Grouted section			





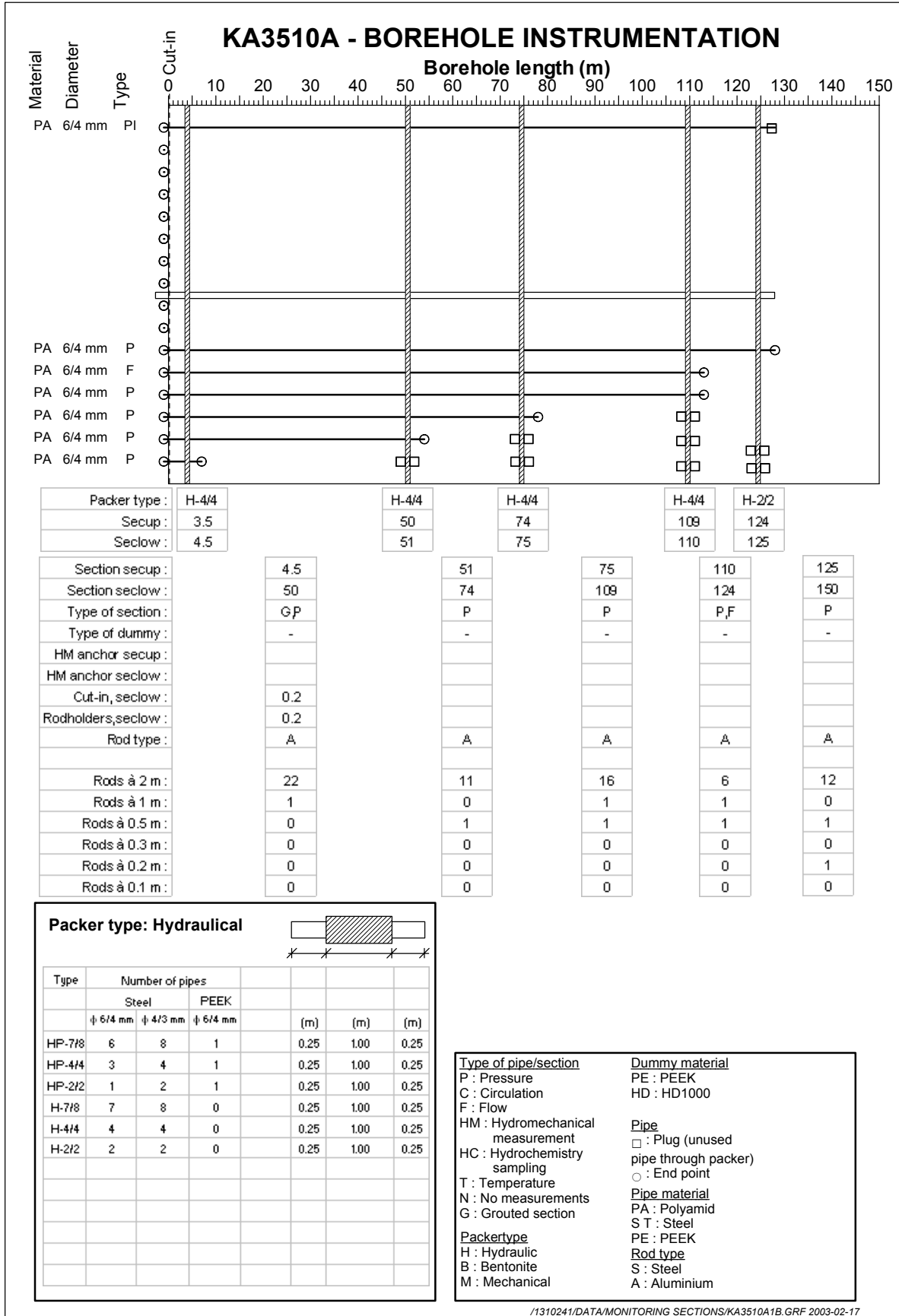
## PACKER POSITION

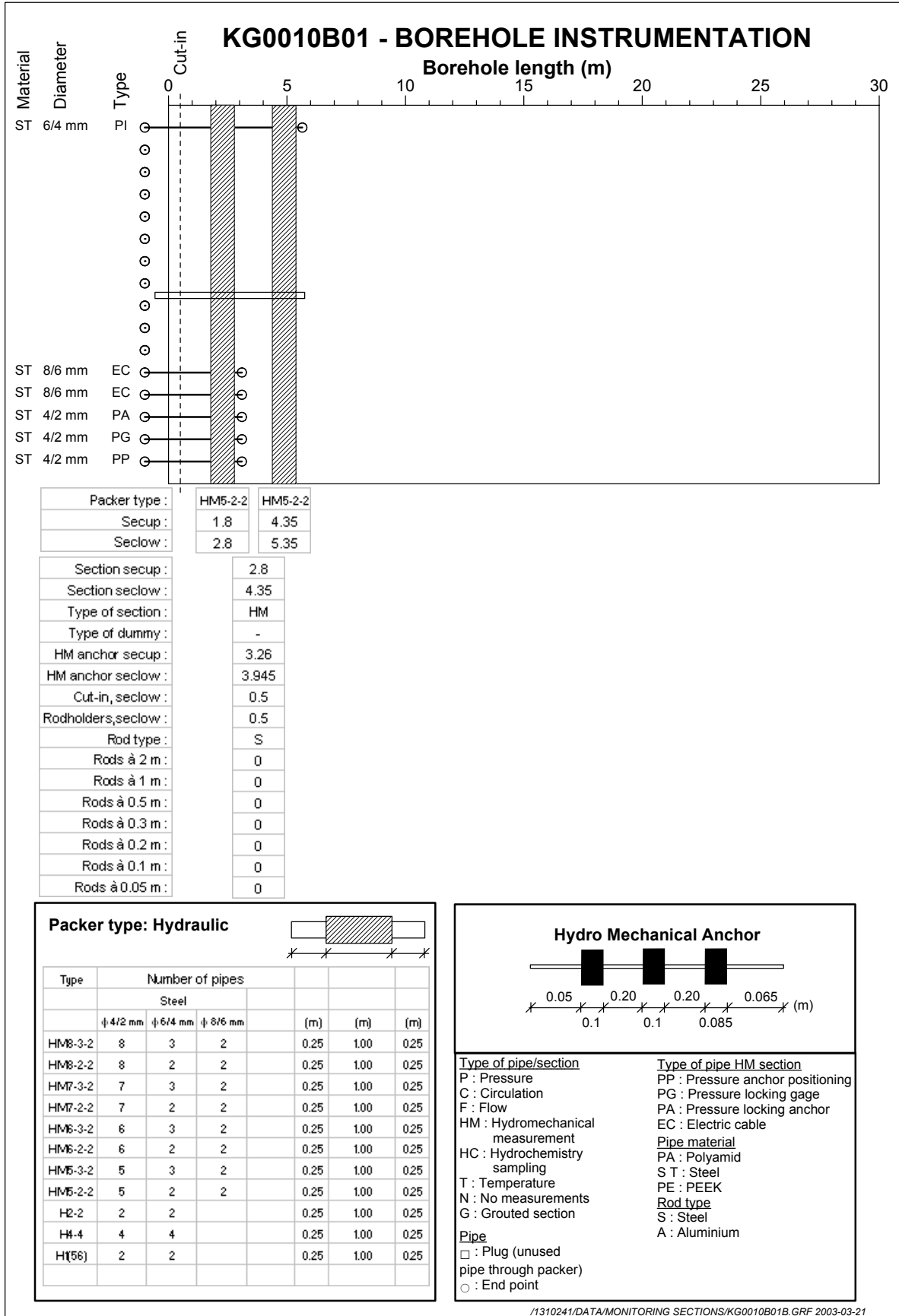
Borehole name: <b>KA3510A</b>	Date design: 2003-02-17
Borehole diametre: 76 mm	Name: TFK
Borehole length: 150.00 m	Remark: 0 - 50 m is grouted
Borehole inclination:	



Section setup :	4.5	51	75	110	125
Section seclow :	50	74	109	124	150
Type of section :	G,P	P	P	P,F	P
Type of dummy :	-	-	-	-	-
HM anchor setup :					
HM anchor seclow :					

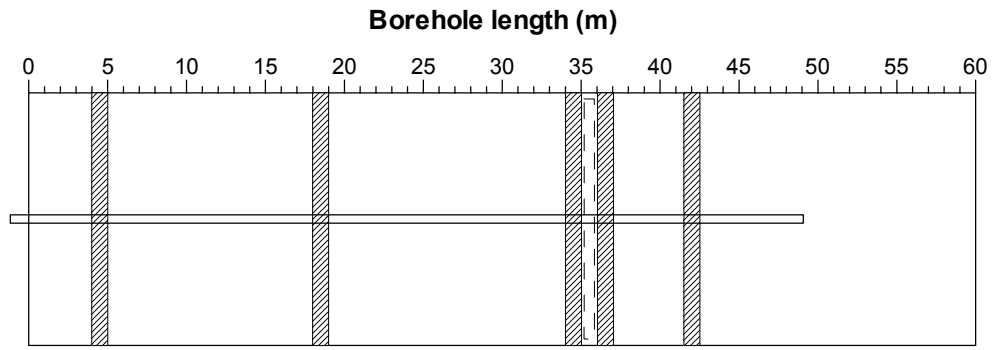
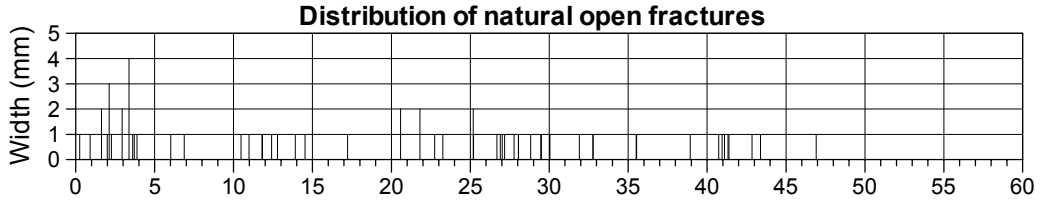
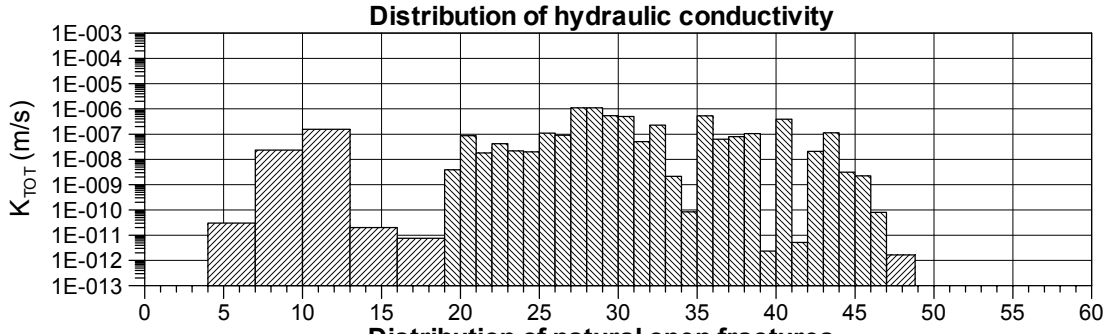
<p><b>Type of measurement section</b></p> <p>P : Pressure          C : Circulation          F : Flow          HM : Hydromechanical measurement          HC : Hydrochemistry sampling          T : Temperature          N : No measurements          G : Grouted section</p>	<p><b>Type of dummy</b></p> <p>PE : PEEK          PEH : PEH</p> <p> PACKER</p> <p> DUMMY</p>
---	--





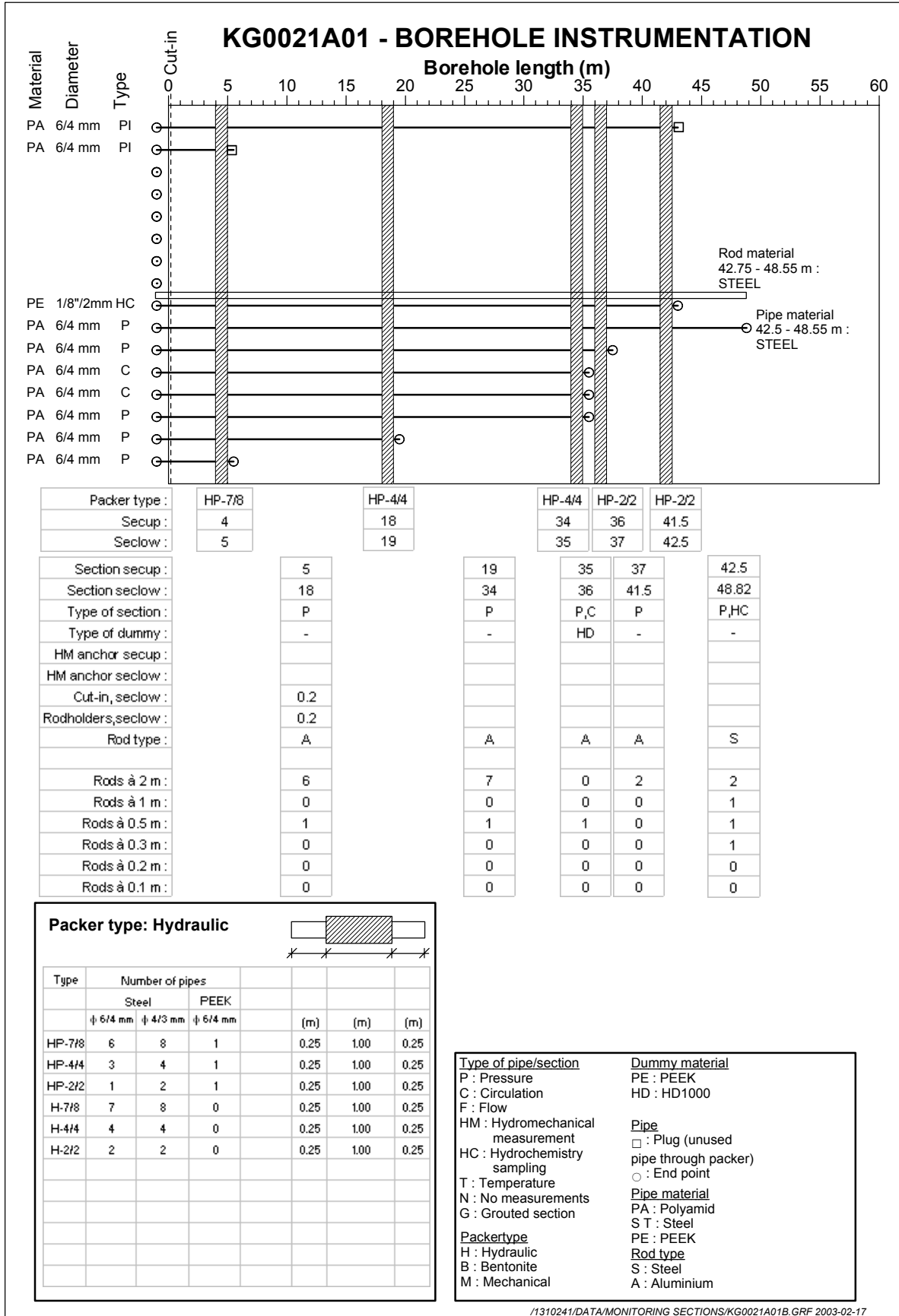
## PACKER POSITION

Borehole name: <b>KG0021A01</b>	Date design: 2003-02-17
Borehole diameter: 76 mm	Name: TFK
Borehole length: 48.82 m	Remark:
Borehole inclination: 18° up	



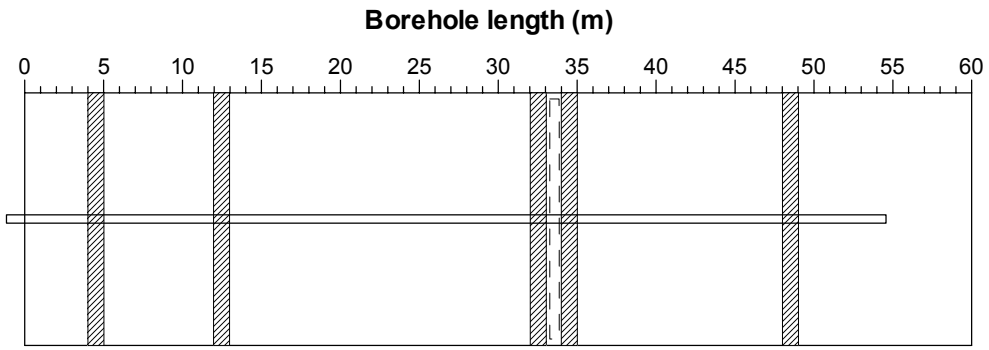
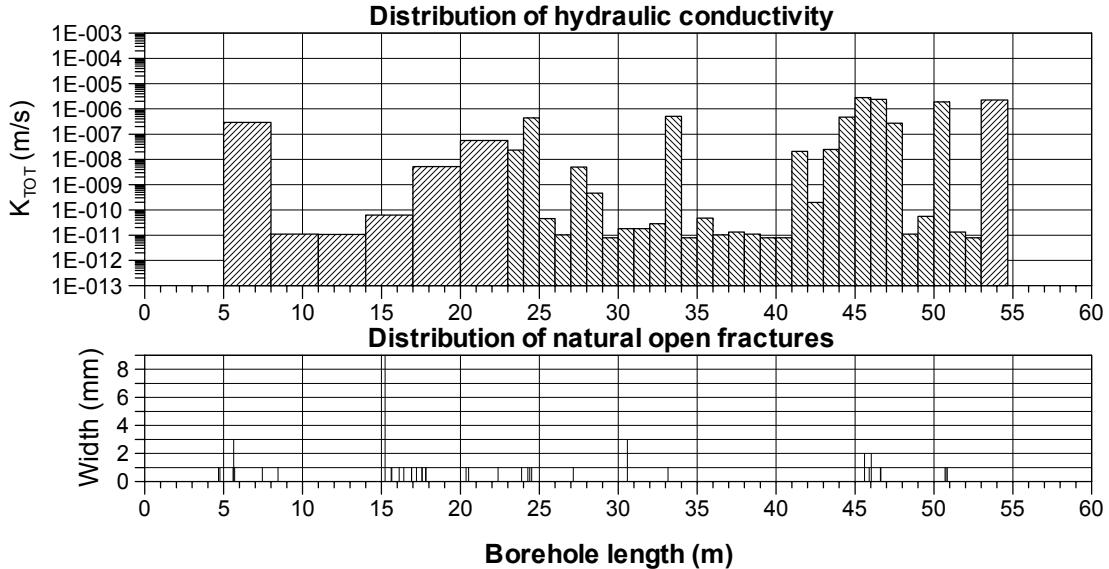
Section setup :	5	19	35	37	42.5
Section seclow :	18	34	36	41.5	48.82
Type of section :	P	P	P,C	P	P,HC
Type of dummy :	-	-	HD	-	-
HM anchor setup :					
HM anchor seclow :					

<p><b>Type of measurement section</b></p> <p>P : Pressure          C : Circulation          F : Flow          HM : Hydromechanical measurement          HC : Hydrochemistry sampling          T : Temperature          N : No measurements          G : Grouted section</p>	<p><b>Type of dummy</b></p> <p>PE : PEEK          HD : HD1000</p> <div style="display: flex; align-items: center; margin-top: 10px;"> <div style="width: 15px; height: 15px; background: repeating-linear-gradient(45deg, transparent, transparent 2px, black 2px, black 4px); border: 1px solid black; margin-right: 5px;"></div> <span>PACKER</span> </div> <div style="display: flex; align-items: center; margin-top: 10px;"> <div style="width: 15px; height: 15px; border: 1px dashed black; margin-right: 5px;"></div> <span>DUMMY</span> </div>
---	---



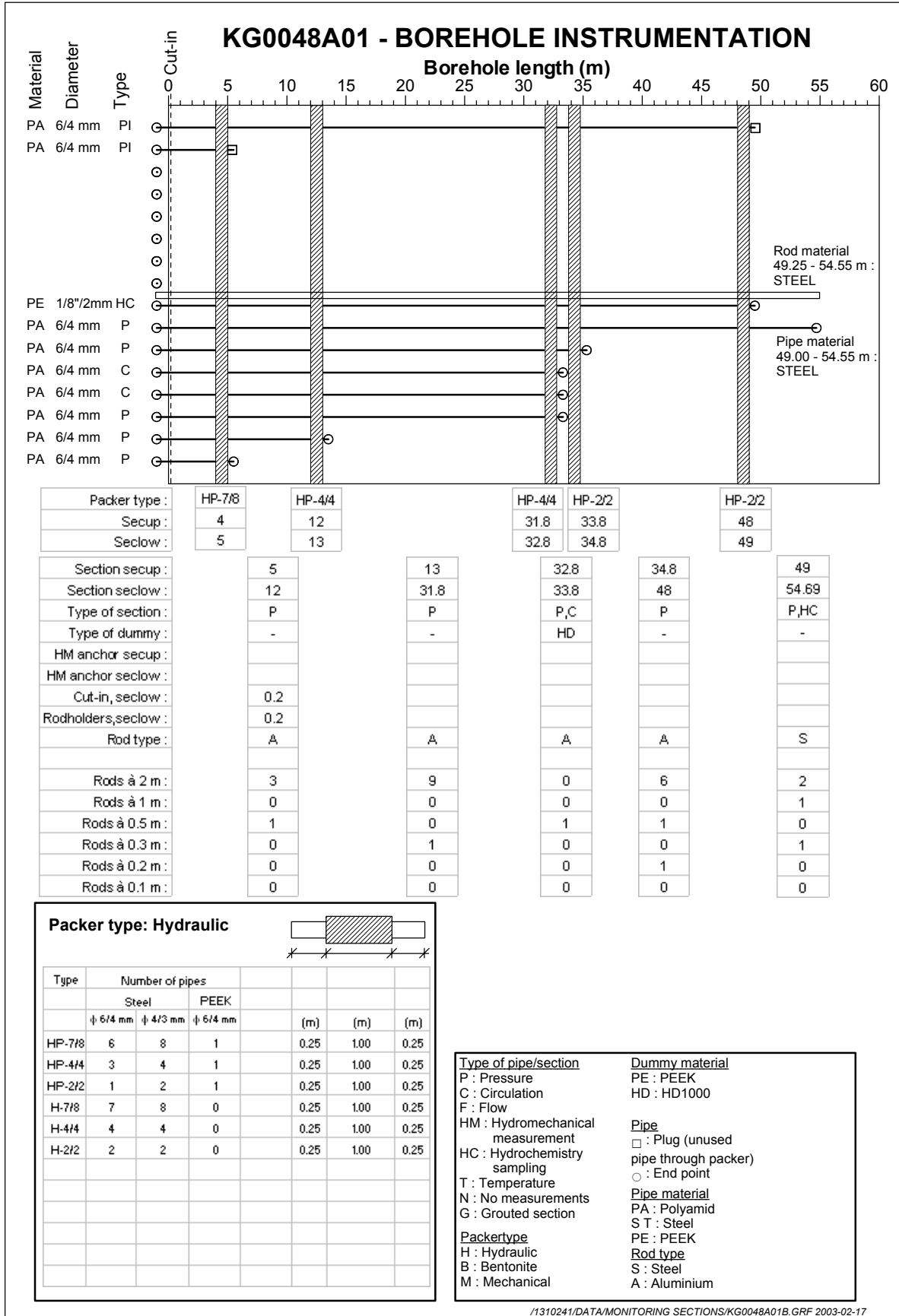
## PACKER POSITION

Borehole name: <b>KG0048A01</b>	Date design: 2003-02-17
Borehole diameter: 76 mm	Name: TFK
Borehole length: 54.69 m	Remark:
Borehole inclination: 14° up	



Section setup :	5	13	32.8	34.8	49
Section seclow :	12	31.8	33.8	48	54.69
Type of section :	P	P	P,C	P	P,HC
Type of dummy :	-	-	HD	-	-
HM anchor setup :					
HM anchor seclow :					

<p><b>Type of measurement section</b></p> <p>P : Pressure          C : Circulation          F : Flow          HM : Hydromechanical measurement          HC : Hydrochemistry sampling          T : Temperature          N : No measurements          G : Grouted section</p>	<p><b>Type of dummy</b></p> <p>PE : PEEK          HD : HD1000</p> <p> PACKER</p> <p> DUMMY</p>
---	--





## APPENDIX 2

### Position of measurement sections along boreholes in tunnel section II

The table of hydro holes presented in this appendix consists of 4 columns described below:

Borehole	-	Borehole name
Section secup (m)	-	The upper (closest to tunnel) end of the observation section
Section seclow (m)	-	The lower end of the observation section
Measurement	-	Index of which kind of measurement is done in this section
		P - Pressure measurement
		C - Water circulation measurements
		F - Flow measurements
		HM - Hydromechanical monitoring
		HC - Hydrochemical sampling



Borehole	Secup (m)	Seclow (m)	Measurement
KA3539G	4	9	P
KA3539G	10	14.85	P,F
KA3539G	15.85	17.6	P, HM, C
KA3539G	18.6	30	P
KA3542G01	3.5	9.5	P
KA3542G01	10.5	17.6	P
KA3542G01	18.6	20.3	P, HM, C
KA3542G01	21.3	26	P
KA3542G01	27	30	P
KA3542G02	2	8	P, F
KA3542G02	9	20.5	P
KA3542G02	21.5	24.6	P
KA3542G02	25.6	27.2	P, HM, C
KA3542G02	28.2	30.01	P
KA3543A01	0.65	2	P
KA3543I01	0.65	2	P
KA3544G01	3.5	7.9	P
KA3544G01	8.9	10.65	P, HM, C
KA3544G01	11.65	12	P
KA3546G01	1.5	5.75	P
KA3546G01	6.75	8.3	P, HM, C
KA3546G01	9.3	12	P
KA3548A01	3	7.8	P
KA3548A01	8.8	10.75	P, HM, C
KA3548A01	11.75	20.5	P, F
KA3548A01	21.5	30	P
KA3548D01	0.65	2	P
KA3548G01	2	5	P
KA3548G01	6	12	P
KA3550G01	1.8	4.2	P
KA3550G01	5.2	7.3	P, HM, C
KA3550G01	8.3	12.03	P

Borehole	Secup (m)	Seclow (m)	Measurement
KA3550G05	1.5	3	P
KA3551G05	1.5	3.1	P
KA3552A01	0.65	2	P
KA3552G01	1.5	3.35	P
KA3552G01	4.35	6.05	P, HM, C
KA3552G01	7.05	12	P
KA3552H01	0.65	2	P
KA3553B01	0.65	2	P
KA3554G01	1.5	4	P
KA3554G01	5	13	P
KA3554G01	14	21.6	P
KA3554G01	22.6	24.15	P, HM, C
KA3554G01	25.15	30.01	P
KA3554G02	1.5	9.5	P
KA3554G02	10.5	12.2	P, HM, C
KA3554G02	13.2	14.9	P
KA3554G02	15.9	21	P
KA3554G02	22	30.01	P
KA3557G	1.5	14	P
KA3557G	15	30.04	P
KA3510A	4.5	50	P
KA3510A	51	74	P
KA3510A	75	109	P
KA3510A	110	124	P,F
KA3510A	125	150	P
KG0010B01	2.8	4.35	HM
KG0021A01	5	18	P
KG0021A01	19	34	P
KG0021A01	35	36	P, C
KG0021A01	37	41.5	P
KG0021A01	42.5	48.82	P, HC
KG0048A01	5	12	P

Borehole	Secup	Seclow	Measurement
	(m)	(m)	
KG0048A01	13	31.8	P
KG0048A01	32.8	33.8	P, C
KG0048A01	34.8	48	P
KG0048A01	49	54.69	P, HC



## **APPENDIX 3**

### Coordinates of boreholes

Coordinate system: Äspö local North map system (ÄSPÖ96).





Hole	Hole chainage	NORTHING X (m)	EASTING Y (m)	Z (m)	Hole category	Prototype section	Comments
DA3545G01	0.00	7 269.530	1 920.500	-449.041	D	2	Hole depth in centre=8.37
DA3545G01	8.37	7 269.535	1 920.486	-457.41	D	2	
DA3551G01	0.00	7 270.382	1 914.560	-448.921	D	2	Hole depth in centre=8.37
DA3551G01	8.37	7 270.385	1 914.560	-457.29	D	2	
DA3569G01	0.00	7 272.939	1 896.743	-448.562	D	1	Hole depth in centre=8.37
DA3569G01	8.37	7 272.935	1 896.741	-456.93	D	1	
DA3575G01	0.00	7 273.792	1 890.804	-448.443	D	1	Hole depth in centre=8.37
DA3575G01	8.37	7 273.790	1 890.798	-456.81	D	1	
DA3581G01	0.00	7 274.644	1 884.865	-448.323	D	1	Hole depth in centre=8.37
DA3581G01	8.37	7 274.645	1 884.872	-456.69	D	1	
DA3587G01	0.00	7 275.496	1 878.926	-448.204	D	1	Hole depth in centre=8.37
DA3587G01	8.37	7 275.486	1 878.917	-456.57	D	1	
KA3510A	0.00	7260.892	1953.796	-448.696	H	2	
KA3510A	3.00	7260.235	1951.287	-450.203	H	2	
KA3510A	6.00	7259.579	1948.777	-451.711	H	2	
KA3510A	9.00	7258.925	1946.268	-453.218	H	2	
KA3510A	12.00	7258.269	1943.759	-454.727	H	2	
KA3510A	15.00	7257.615	1941.250	-456.236	H	2	
KA3510A	18.00	7256.966	1938.738	-457.742	H	2	
KA3510A	21.00	7256.324	1936.223	-459.247	H	2	
KA3510A	24.00	7255.690	1933.705	-460.749	H	2	
KA3510A	27.00	7255.056	1931.188	-462.253	H	2	
KA3510A	30.00	7254.422	1928.671	-463.757	H	2	
KA3510A	33.00	7253.789	1926.153	-465.261	H	2	
KA3510A	36.00	7253.155	1923.636	-466.765	H	2	
KA3510A	39.00	7252.523	1921.118	-468.269	H	2	
KA3510A	42.00	7251.892	1918.600	-469.772	H	2	
KA3510A	45.00	7251.261	1916.081	-471.276	H	2	
KA3510A	48.00	7250.633	1913.562	-472.779	H	2	
KA3510A	51.00	7250.007	1911.043	-474.283	H	2	
KA3510A	54.00	7249.382	1908.523	-475.786	H	2	
KA3510A	57.00	7248.758	1906.003	-477.289	H	2	
KA3510A	60.00	7248.136	1903.482	-478.792	H	2	
KA3510A	63.00	7247.515	1900.961	-480.295	H	2	
KA3510A	66.00	7246.896	1898.440	-481.797	H	2	
KA3510A	69.00	7246.277	1895.917	-483.299	H	2	
KA3510A	72.00	7245.660	1893.394	-484.800	H	2	
KA3510A	75.00	7245.044	1890.870	-486.300	H	2	
KA3510A	78.00	7244.429	1888.345	-487.799	H	2	

<p>Hole category</p> <p>D=Deposition Hole</p> <p>H=Monitoring Hole, Investigation Hole, Long Hole</p> <p>P=Monitoring Hole, Investigation Hole, Short Hole</p> <p>I= Investigation Hole</p> <p>T=Temperature Hole</p> <p>LT= Lead-Through Hole</p>
--

Hole	Hole chainage	NORTHING	EASTING	Z	Hole category	Prototype section	Comments
		X	Y				
		(m)	(m)	(m)			
KA3510A	81.00	7243.815	1885.820	-489.298	H	2	
KA3510A	84.00	7243.201	1883.294	-490.796	H	2	
KA3510A	87.00	7242.589	1880.768	-492.294	H	2	
KA3510A	90.00	7241.979	1878.242	-493.792	H	2	
KA3510A	93.00	7241.370	1875.715	-495.290	H	2	
KA3510A	96.00	7240.763	1873.187	-496.788	H	2	
KA3510A	99.00	7240.157	1870.659	-498.285	H	2	
KA3510A	102.00	7239.550	1868.131	-499.782	H	2	
KA3510A	105.00	7238.945	1865.602	-501.278	H	2	
KA3510A	108.00	7238.340	1863.073	-502.773	H	2	
KA3510A	111.00	7237.736	1860.543	-504.268	H	2	
KA3510A	117.00	7236.529	1855.481	-507.255	H	2	
KA3510A	150.00	7229.890	1827.641	-523.683	H	2	
KA3510A	150.06	7229.878	1827.590	-523.713	H	2	
KA3539G	0.00	7268.774	1927.266	-449.191	H	2	
KA3539G	30.01	7269.135	1922.308	-478.786	H	2	
KA3542G01	0.00	7268.608	1923.435	-449.074	H	2	
KA3542G01	30.04	7247.594	1920.218	-470.298	H	2	
KA3542G02	0.00	7269.604	1923.540	-449.070	H	2	
KA3542G02	30.01	7290.987	1925.883	-469.996	H	2	
KA3543A01	0.00	7266.837	1921.611	-446.801	P	2	
KA3543A01	2.06	7265.629	1919.943	-446.830	P	2	
KA3543I01	0.00	7269.402	1921.940	-444.084	P	2	
KA3543I01	2.06	7268.739	1921.756	-442.142	P	2	
KA3544G01	0.00	7270.224	1921.445	-448.952	H	2	
KA3544G01	12.00	7270.224	1921.445	-460.952	H	2	
KA3545G	0.00	7 269.60	1 921.28	-449.10	I	2	Gone, at position of deposition hole
KA3545G	8.04	7269.60	1920.06	-457.01	I	2	Gone, at position of deposition hole
KA3546G01	0.00	7268.819	1919.555	-448.894	H	2	
KA3546G01	12.00	7268.771	1919.543	-460.894	H	2	
KA3548A01	0.00	7267.473	1917.175	-446.576	H	2	
KA3548A01	3.00	7264.509	1916.738	-446.738	H	2	
KA3548A01	6.00	7261.546	1916.303	-446.902	H	2	
KA3548A01	9.00	7258.581	1915.867	-447.065	H	2	
KA3548A01	30.00	7237.835	1912.816	-448.206	H	2	

Hole	Hole chainage	NORTHING	EASTING	Z	Hole category	Prototype section	Comments
		X	Y				
		(m)	(m)	(m)			
KA3548D01	0.00	7272.404	1917.543	-445.865	P	2	
KA3548D01	2.06	7273.654	1919.178	-445.768	P	2	
KA3548G01	0.00	7269.928	1917.518	-449.000	H	2	
KA3548G01	3.00	7269.935	1917.542	-452.000	H	2	
KA3548G01	6.00	7269.935	1917.544	-455.000	H	2	
KA3548G01	9.00	7269.941	1917.566	-458.000	H	2	
KA3548G01	12.01	7269.947	1917.588	-461.010	H	2	
KA3550G01	0.00	7271.088	1915.503	-448.770	H	2	
KA3550G01	12.03	7271.028	1915.347	-460.799	H	2	
KA3550G05	0.00	7269.932	1915.640	-448.964	P	2	
KA3550G05	3.00	7269.970	1915.658	-451.964	P	2	
KA3551G05	0.00	7270.848	1913.483	-448.912	P	2	
KA3551G05	3.10	7270.852	1913.483	-452.012	P	2	
KA3551G	0.00	7 270.39	1 915.43	-448.93	I	2	Gone, at position of deposition hole
KA3551G	8.04	7 270.37	1 913.99	-456.80	I	2	Gone, at position of deposition hole
KA3552A01	0.00	7268.134	1912.430	-446.623	P	2	
KA3552A01	2.06	7266.912	1910.774	-446.723	P	2	
KA3552G01	0.00	7269.678	1913.606	-448.773	H	2	
KA3552G01	12.01	7269.606	1913.690	-460.782	H	2	
KA3552H01	0.00	7269.918	1912.573	-443.984	P	2	
KA3552H01	2.10	7269.873	1911.467	-442.199	P	2	
KA3553B01	0.00	7273.100	1912.554	-446.550	P	2	
KA3553B01	2.02	7274.681	1912.780	-447.787	P	2	
KA3554G01	0.00	7270.279	1911.531	-448.835	H	2	
KA3554G01	30.01	7249.286	1908.511	-470.067	H	2	
KA3554G02	0.00	7271.306	1911.654	-448.820	H	2	
KA3554G02	30.01	7292.314	1914.672	-470.037	H	2	
KA3557G	0.00	7271.259	1909.495	-448.847	H	2	
KA3557G	30.04	7271.349	1905.049	-478.556	H	2	
KA3563A01	0.00	7269.845	1901.729	-447.061	P	1	
KA3563A01	2.06	7268.639	1900.082	-447.336	P	1	

Hole	Hole chainage	NORTHING	EASTING	Z	Hole category	Prototype section	Comments
		X	Y				
		(m)	(m)	(m)			
KA3563D01	0.00	7274.672	1902.147	-446.155	P	1	
KA3563D01	2.01	7275.86	1903.766	-446.068	P	1	
KA3563G	0.00	7272.200	1903.528	-448.694	H	1	
KA3563G	30.00	7272.920	1898.340	-478.233	H	1	
KA3563I01	0.00	7272.440	1901.919	-443.642	P	1	
KA3563I01	2.15	7272.087	1901.398	-441.586	P	1	
KA3566C01	0.00	7270.165	1898.849	-445.562	P	1	
KA3566C01	2.10	7268.883	1897.191	-445.434	P	1	
KA3566G01	0.00	7272.005	1899.636	-448.566	H	1	
KA3566G01	30.01	7250.985	1896.388	-469.737	H	1	
KA3566G02	0.00	7272.998	1899.806	-448.568	H	1	
KA3566G02	30.01	7294.461	1902.714	-469.341	H	1	
KA3568D01	0.00	7275.377	1897.276	-445.830	P	1	
KA3568D01	2.30	7276.716	1899.144	-445.921	P	1	
KA3569G	0.00	7 272.99	1 897.64	-448.57	I	1	Gone, at position of deposition hole
KA3569G	8.04	7272.98	1896.29	-456.45	I	1	Gone, at position of deposition hole
KA3571G01	0.00	7 273.232	1 894.749	-448.527	T	1	
KA3571G01	10.00	7 273.339	1 894.721	-458.526			
KA3572G01	0.00	7273.358	1893.802	-448.512	H	1	
KA3572G01	12.00	7273.298	1893.742	-460.512	H	1	
KA3573A	0.00	7270.896	1893.281	-446.068	H	1	
KA3573A	3.00	7267.931	1892.840	-446.171	H	1	
KA3573A	6.00	7264.965	1892.402	-446.280	H	1	
KA3573A	9.00	7261.998	1891.969	-446.392	H	1	
KA3573A	40.07	7231.275	1887.485	-447.552	H	1	
KA3573C01	0.00	7271.294	1891.464	-445.132	P	1	
KA3573C01	2.05	7270.267	1890.134	-443.958	P	1	
KA3574D01	0.00	7276.116	1891.143	-445.120	P	1	
KA3574D01	2.05	7277.250	1892.791	-444.674	P	1	
KA3574G01	0.00	7274.504	1891.733	-448.332	H	1	
KA3574G01	12.00	7274.444	1891.577	-460.331	H	1	

Hole	Hole chainage	NORTHING	EASTING	Z	Hole category	Prototype section	Comments
		X	Y				
		(m)	(m)	(m)			
KA3575G	0.0	7273.90	1891.67	-448.48	I	1	
KA3575G	8.04	7274.12	1890.42	-456.38	I	1	
KA3575G06	0.00	7272.718	1890.647	-448.207	T	1	
KA3575G06	15.10	7267.054	1889.76	-462.176	T	1	
KA3575G07	0.00	7272.44	1890.6	-448.064	T	1	
KA3575G07	13.55	7261.36	1888.927	-455.682	T	1	
KA3576G01	0.00	7273.104	1889.874	-448.274	H	1	
KA3576G01	12.01	7272.960	1889.778	-460.283	H	1	
KA3577G01	0.00	7 274.081	1 888.803	-448.401	T	1	
KA3577G01	10.00	7 273.920	1 888.887	-458.399	T	1	
KA3578C01	0.00	7271.850	1887.023	-445.337	P	1	
KA3578C01	2.09	7270.579	1885.375	-445.532	P	1	
KA3578G01	0.00	7274.219	1887.842	-448.384	H	1	
KA3578G01	12.58	7274.156	1887.641	-460.962	H	1	
KA3578G02	0.00	7 274.295	1 887.235	-448.372	T	1	
KA3578G02	10.00	7 274.247	1 887.391	-458.371	T	1	
KA3578H01	0.00	7274.074	1887.146	-443.378	P	1	
KA3578H01	1.90	7274.017	1886.171	-441.748	P	1	
KA3579D01	0.00	7276.885	1886.525	-445.429	P	1	
KA3579D01	2.00	7278.054	1888.147	-445.464	P	1	
KA3579G	0.00	7274.422	1886.684	-448.366	H	1	
KA3579G	22.65	7274.535	1886.457	-471.015	H	1	
KA3581G	0.00	7274.70	1885.71	-448.33	I	1	Gone, at position of deposition hole
KA3581G	8.04	7274.84	1884.55	-456.25	I	1	Gone, at position of deposition hole
KA3584G01	0.00	7275.076	1881.877	-448.246	H	1	
KA3584G01	12.00	7274.944	1881.793	-460.245	H	1	
KA3586G01	0.00	7275.93	1879.49	-448.15	I	1	Gone, at position of deposition hole
KA3586G01	8.00	7276.02	1879.31	-456.14	I	1	Gone, at position of deposition hole
KA3587G	0.00	7275.596	1879.895	-448.208	I	1	Gone, at position of deposition hole
KA3587G	8.04	7275.773	1878.475	-456.120	I	1	Gone, at position of deposition hole

Hole	Hole chainage	NORTHING X (m)	EASTING Y (m)	Z (m)	Hole category	Prototype section	Comments
KA3588C01	0.00	7273.255	1876.954	-445.443	P	1	
KA3588C01	2.04	7272.025	1875.333	-445.585	P	1	
KA3588D01	0.00	7278.152	1877.826	-445.237	P	1	
KA3588D01	1.90	7279.241	1879.382	-445.296	P	1	
KA3588G01	0.00	7275.07	1878.34	-448.10	I	1	Gone, at position of deposition hole
KA3588G01	8.00	7275.00	1878.26	-456.10	I	1	Gone, at position of deposition hole
KA3588I01	0.00	7275.924	1877.473	-443.338	P	1	
KA3588I01	1.96	7276.729	1877.547	-441.553	P	1	
KA3589G01	0.00	7 275.801	1 876.931	-448.148	T	1	
KA3589G01	10.00	7 275.828	1 876.893	-458.148			
KA3590G01	0.00	7275.410	1875.889	-448.063	H	1	
KA3590G01	30.06	7254.076	1873.397	-469.093	H	1	
KA3590G02	0.00	7276.412	1876.052	-448.080	H	1	
KA3590G02	30.05	7297.885	1879.046	-468.888	H	1	
KA3592C01	0.00	7273.859	1872.861	-445.254	P	1	
KA3592C01	2.10	7272.621	1871.172	-445.092	P	1	
KA3592G01	0.00	7 276.223	1 873.982	-448.079	T	1	
KA3592G01	10.00	7 276.230	1 874.025	-458.079			
KA3593G	0.00	7276.375	1873.859	-448.073	H	1	
KA3593G	30.02	7276.856	1868.598	-477.625	H	1	
KA3597D01	0.00	7279.350	1869.120	-445.096	P	1	
KA3597D01	2.22	7280.669	1870.902	-444.978	P	1	
KA3597G01	0.00	7 276.804	1 869.935	-448.026	T	1	
KA3597G01	10.00	7 276.758	1 869.927	-458.026	T	1	
KA3597H01	0.00	7276.032	1868.465	-443.177	P	1	
KA3597H01	2.06	7275.606	1867.367	-441.487	P	1	
KA3600F	0.00	7275.456	1866.012	-445.583	H	1	
KA3600F	3.00	7274.343	1863.228	-445.679	H	1	
KA3600F	6.00	7273.236	1860.441	-445.774	H	1	
KA3600F	9.00	7272.133	1857.653	-445.862	H	1	
KA3600F	50.10	7257.020	1819.452	-447.068	H	1	

Hole	Hole chainage	NORTHING X (m)	EASTING Y (m)	Z (m)	Hole category	Prototype section	Comments
HG0020A01	0.00	7297.41	1941.63	-446.30	LT		
HG0020A01	3.00	7294.95	1939.91	-446.46	LT		
HG0020A01	6.00	7292.49	1938.20	-446.61	LT		
HG0020A01	9.00	7290.03	1936.49	-446.76	LT		
HG0020A01	12.00	7287.57	1934.78	-446.92	LT		
HG0020A01	15.00	7285.11	1933.07	-447.08	LT		
HG0020A01	31.84	7271.30	1923.48	-447.98	LT		
HG0021A01	0.00	7297.65	1940.83	-446.29	LT		
HG0021A01	3.00	7295.21	1939.10	-446.38	LT		
HG0021A01	6.00	7292.76	1937.37	-446.47	LT		
HG0021A01	9.00	7290.31	1935.64	-446.56	LT		
HG0021A01	12.00	7287.86	1933.91	-446.65	LT		
HG0021A01	15.00	7285.41	1932.18	-446.74	LT		
HG0021A01	18.00	7282.96	1930.45	-446.84	LT		
HG0021A01	21.00	7280.51	1928.72	-446.93	LT		
HG0021A01	31.72	7271.76	1922.53	-447.26	LT		
HG0022A01	0.00	7297.95	1940.12	-446.29	LT		
HG0022A01	3.00	7295.51	1938.38	-446.43	LT		
HG0022A01	6.00	7293.08	1936.63	-446.58	LT		
HG0022A01	9.00	7290.64	1934.89	-446.73	LT		
HG0022A01	12.00	7288.20	1933.15	-446.88	LT		
HG0022A01	15.00	7285.76	1931.40	-447.02	LT		
HG0022A01	33.44	7271.60	1921.26	-447.90	LT		
HG0022A02	0.00	7298.12	1940.01	-445.26	LT		
HG0022A02	3.00	7295.72	1938.21	-445.45	LT		
HG0022A02	6.00	7293.32	1936.42	-445.64	LT		
HG0022A02	32.74	7271.94	1920.47	-447.41	LT		
HG0023A01	0.00	7298.58	1938.58	-445.43	LT		
HG0023A01	3.00	7296.21	1936.74	-445.63	LT		
HG0023A01	6.00	7293.85	1934.91	-445.84	LT		
HG0023A01	33.53	7272.16	1918.06	-447.80	LT		
HG0023A02	0.00	7298.84	1937.90	-444.89	LT		
HG0023A02	3.00	7296.55	1935.97	-445.09	LT		
HG0023A02	6.00	7296.55	1934.04	-445.30	LT		
HG0023A02	34.27	7272.70	1915.87	-447.26	LT		
HG0024A01	0.00	7298.85	1937.43	-445.44	LT		
HG0024A01	3.00	7296.21	1936.74	-445.63	LT		
HG0024A01	6.00	7294.34	1933.49	-445.84	LT		
HG0024A01	35.06	7272.52	1914.40	-447.79	LT		

Hole	Hole chainage	NORTHING X (m)	EASTING Y (m)	Z (m)	Hole category	Prototype section	Comments
HG0024A02	0.00	7299.10	1937.03	-444.78	LT		
HG0024A02	3.00	7296.87	1935.04	-444.99	LT		
HG0024A02	6.00	7294.63	1933.05	-445.20	LT		
HG0024A02	35.21	7272.91	1913.63	-447.33	LT		
HG0025A01	0.00	7299.03	1936.69	-445.41	LT		
HG0025A01	3.00	7296.84	1934.65	-445.61	LT		
HG0025A01	6.00	7294.65	1932.61	-445.80	LT		
HG0025A01	36.00	7272.77	1912.19	-447.81	LT		
HG0025A02	0.00	7299.24	1936.47	-444.72	LT		
HG0025A02	3.00	7297.08	1934.40	-444.93	LT		
HG0025A02	6.00	7294.92	1932.33	-445.13	LT		
HG0025A02	36.20	7273.20	1911.46	-447.26	LT		
HG0025A03	0.00	7299.20	1936.23	-445.41	LT		
HG0025A03	3.00	7297.49	1933.76	-445.55	LT		
HG0025A03	6.00	7295.79	1931.30	-445.69	LT		
HG0025A03	43.76	7274.52	1900.16	-447.58	LT		
HG0026A01	0.00	7299.40	1935.99	-444.78	LT		
HG0026A01	3.00	7297.73	1933.50	-444.92	LT		
HG0026A01	6.00	7296.07	1931.01	-445.07	LT		
HG0026A01	44.10	7274.95	1899.35	-447.05	LT		
HG0026A02	0.00	7299.62	1935.75	-445.36	LT		
HG0026A02	3.00	7297.99	1933.24	-445.48	LT		
HG0026A02	6.00	7296.37	1930.72	-445.60	LT		
HG0026A02	45.51	7275.03	1897.51	-447.35	LT		
HG0027A01	0.00	7299.78	1934.93	-445.30	LT		
HG0027A01	3.00	7298.26	1932.35	-445.41	LT		
HG0027A01	6.00	7296.73	1929.77	-445.54	LT		
HG0027A01	9.00	7295.21	1927.19	-445.66	LT		
HG0027A01	12.00	7293.69	1924.60	-445.79	LT		
HG0027A01	15.00	7292.17	1922.02	-445.91	LT		
HG0027A01	18.00	7290.65	1914.26	-446.04	LT		
HG0027A01	21.00	7289.14	1916.85	-446.16	LT		
HG0027A01	24.00	7287.62	1914.26	-446.29	LT		
HG0027A01	48.07	7275.52	1893.48	-447.36	LT		
HG0028A01	0.00	7299.95	1934.46	-444.66	LT		
HG0028A01	3.00	7298.45	1931.87	-444.78	LT		
HG0028A01	6.00	7296.95	1929.27	-444.91	LT		
HG0028A01	9.00	7295.45	1926.67	-445.04	LT		



Hole	Hole chainage	NORTHING	EASTING	Z	Hole category	Prototype section	Comments
		X	Y				
		(m)	(m)	(m)			
HG0028A01	48.42	7275.89	1892.50	-446.84	LT		
HG0028A02	0.00	7300.23	1934.00	-445.31	LT		
HG0028A02	3.00	7298.75	1931.39	-445.41	LT		
HG0028A02	6.00	7297.28	1928.78	-445.52	LT		
HG0028A02	9.00	7295.81	1926.17	-445.63	LT		
HG0028A02	49.70	7275.99	1890.66	-447.22	LT		
HG0029A01	0.00	7300.19	1933.56	-444.66	LT		
HG0029A01	3.00	7298.77	1930.92	-444.78	LT		
HG0029A01	6.00	7297.35	1928.28	-444.90	LT		
HG0029A01	9.00	7295.93	1925.64	-445.02	LT		
HG0029A01	50.50	7276.43	1889.04	-446.82	LT		
HG0029A02	0.00	7300.51	1933.07	-445.35	LT		
HG0029A02	3.00	7299.09	1930.43	-445.45	LT		
HG0029A02	6.00	7297.68	1927.78	-445.55	LT		
HG0029A02	9.00	7296.27	1925.14	-445.66	LT		
HG0029A02	51.73	7276.38	1887.35	-447.27	LT		
HG0030A01	0.00	7300.65	1932.79	-444.58	LT		
HG0030A01	3.00	7299.26	1930.13	-444.69	LT		
HG0030A01	6.00	7297.88	1927.47	-444.79	LT		
HG0030A01	9.00	7296.50	1924.81	-444.90	LT		
HG0030A01	52.19	7276.76	1886.44	-446.66	LT		
HG0030A02	0.00	7300.88	1932.00	-445.31	LT		
HG0030A02	3.00	7299.51	1929.33	-445.40	LT		
HG0030A02	6.00	7298.15	1926.67	-445.50	LT		
HG0030A02	9.00	7296.78	1923.99	-445.59	LT		
HG0030A02	53.43	7276.75	1884.37	-447.23	LT		
HG0031A01	0.00	7300.99	1931.62	-444.58	LT		
HG0031A01	3.00	7299.65	1928.94	-444.68	LT		
HG0031A01	6.00	7298.30	1926.26	-444.79	LT		
HG0031A01	9.00	7296.96	1923.58	-444.89	LT		
HG0031A01	53.55	7277.22	1883.68	-446.58	LT		
HG0032A01	0.00	7301.31	1930.79	-444.53	LT		
HG0032A01	3.00	7299.98	1928.10	-444.64	LT		
HG0032A01	6.00	7298.65	1925.41	-444.74	LT		
HG0032A01	9.00	7297.32	1922.73	-444.85	LT		
HG0032A01	54.28	7277.45	1882.08	-446.60	LT		
HG0032A02	0.00	7301.56	1930.46	-445.26	LT		
HG0032A02	3.00	7300.29	1927.75	-445.36	LT		

Hole	Hole chainage	NORTHING	EASTING	Z	Hole category	Prototype section	Comments
		X	Y				
		(m)	(m)	(m)			
HG0032A02	6.00	7299.02	1925.03	-445.46	LT		
HG0032A02	9.00	7297.75	1922.31	-445.56	LT		
HG0032A02	12.00	7296.49	1919.59	-445.66	LT		
HG0032A02	15.00	7295.23	1916.87	-445.77	LT		
HG0032A02	18.00	7293.98	1914.15	-445.87	LT		
HG0032A02	21.00	7292.72	1911.43	-445.98	LT		
HG0032A02	24.00	7291.47	1908.70	-446.09	LT		
HG0032A02	57.74	7277.53	1878.01	-447.43	LT		
HG0033A01	0.00	7302.01	1928.74	-445.10	LT		
HG0033A01	3.00	7300.77	1926.01	-445.20	LT		
HG0033A01	6.00	7300.77	1923.28	-445.29	LT		
HG0033A01	9.00	7298.30	1917.81	-445.39	LT		
HG0033A01	12.00	7297.07	1917.81	-445.48	LT		
HG0033A01	15.00	7295.84	1915.08	-445.58	LT		
HG0033A01	18.00	7294.61	1912.34	-445.68	LT		
HG0033A01	21.00	7293.39	1909.61	-445.77	LT		
HG0033A01	58.98	7278.16	1874.85	-447.10	LT		
KG0010B01	0.00	7299.937	1954.575	-446.916			Testhole for HM equipment
KG0010B01	6.10	7305.263	1951.641	-447.403			
KG0021A01	0.00	7297.915	1941.001	-445.153	H		
KG0021A01	3.00	7295.726	1939.160	-444.246	H		
KG0021A01	6.00	7293.539	1937.317	-443.338	H		
KG0021A01	9.00	7291.353	1935.476	-442.427	H		
KG0021A01	48.82	7262.334	1911.037	-430.334	H		
KG0023A01	0.00	7298.42	1939.36	-445.36	LT		
KG0023A01	3.00	7296.03	1937.55	-445.57	LT		
KG0023A01	6.00	7293.65	1935.74	-445.79	LT		
KG0027A01	0.00	7299.66	1935.40	-445.08	LT		
KG0027A01	3.00	7298.10	1932.84	-445.19	LT		
KG0027A01	6.00	7296.54	1930.28	-445.29	LT		
KG0033A01	0.00	7301.76	1929.81	-445.08	LT		
KG0033A01	3.00	7300.52	1927.08	-445.19	LT		
KG0033A01	6.00	7299.27	1924.36	-445.29	LT		
KG0048A01	0.00	7307.032	1915.444	-444.494	H		
KG0048A01	3.00	7304.877	1913.490	-443.762	H		
KG0048A01	6.00	7302.724	1911.533	-443.030	H		
KG0048A01	9.00	7300.574	1909.572	-442.305	H		
KG0048A01	54.69	7267.818	1879.695	-431.259	H		

## **APPENDIX 4**

### Denominations on cables and tubes from the Prototype Repository

Cable and tube length in tables are approximate.



## Denominations on cables and tubes from the Prototype Repository

Over 1000 cables and tubes will be led out from the Prototype Repository, into the G-tunnel (508 from Section 1 and about 500 from Section 2). This includes also a number of multi-cables. In order to put all these cables and tubes in order it is necessary to have a system for the denominations of them. At installation, every cable/tube will be marked in both ends. Corresponding marks will be done on instruments and tubes from packers installed in advance, in order to facilitate the later connection.

The suggested system for the denominations is in accordance with the following example:

Tunnel section I:

TBU10111 where

T describes the type of measuring, for example:

- T temperature
- P total pressure
- U pore water pressure (in BU, BA and RO)
- W water content
- F flow rate
- C Circulation
- K Sampling for chemistry (PEEK tubes)
- S Stress - Mechanical measurements
- H Deformation - Hydromechanical measurements
- D Deformation - Mechanical measurements
- B Box - Mechanical measurements- Multicables
- M Movements of canister
- A Acoustic emission - Wave velocity
- G Geoelectrics - Multicables
- X Packer inflation
- E Electrical power cables

BU describes where the measuring takes place.

- BU buffer
- BA backfill
- RO rock
- PL plug
- CA canister

10111 serial number with five characters.

- First character can be a letter or a figure: A is the main tunnel (tunnel A) and 1-6 is the deposition holes with No 1 as the deposition hole DA3587G01.
- The second to fifth character specify the position in the buffer, backfill or borehole according to a separate list.
- If it is a borehole the second and third character specifies the borehole. In the TBM tunnel the first bore hole is the one closest to the end of the TBM tunnel (chainage 3600m). In a deposition hole the first bore hole is the one closest to the bottom of the deposition hole.

In the case the borehole are having almost the same co-ordinate along the tunnel/depositionhole the bore hole numbers are defined as follows. Looking towards the end of the tunnel or down in the deposition holes, the numbers are defined clockwise starting from top of the tunnel or North in the deposition holes, see Figure below.

- The fourth figure is the bore hole section with 1 as the section deepest down in a borehole.
- The fifth figure is a serial number for the measurement in a certain borehole section of the same type of measurements (Circulation is an example that should get figures 1 and 2).
- If the fourth and fifth figures are not needed the figures are set to 0.

Tunnel section II:

TBCxxxxy where

T describes the type of measuring, for example:

- T temperature
- P total pressure and water pressure in R
- U pore water pressure (in B and F)
- V velocity of corrosion
- W water content
- F flow rate
- C Circulation
- K Sampling for chemistry (PEEK tubes)
- S Stress - Mechanical measurements
- H Deformation - Hydromechanical measurements
- D Deformation - Mechanical measurements
- B Box - Mechanical measurements- Multicables
- M Movements of canister
- A Acoustic emission - Wave velocity
- G Geoelectrics - Multicables
- X Packer inflation
- E Electrical power cables

B describes where the measuring takes place.

- B buffer
- F backfill
- R rock
- P plug
- C canister

C Character can be a letter or a figure: A is the main tunnel (tunnel A) and 1-6 is the deposition holes with No 1 as the deposition hole DA3587G01.

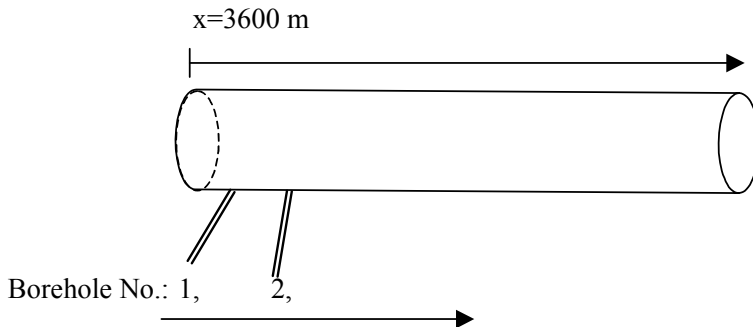
xxxxy serial number with four characters.

- Buffer, backfill ,plug and canister: The first to third character specify the position in the buffer, backfill, plug or canister.
- Boreholes:

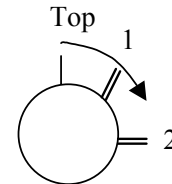
- If it is a borehole the first and second character specifies the borehole. In the TBM tunnel the first bore hole is the one closest to the end of the TBM tunnel (chainage 3600m). In a deposition hole the first bore hole is the one closest to the bottom of the deposition hole. In the case the borehole are having almost the same co-ordinate along the tunnel/depositionhole the bore hole numbers are defined as follows. Looking towards the end of the tunnel or down in the deposition holes, the numbers are defined clockwise starting from top of the tunnel or North in the deposition holes, see Figure below.
- The third figure is the bore hole section with 1 as the section deepest down in a borehole.
- The fourth figure is a serial number for the measurement in a certain borehole section of the same type of measurements (Circulation is an example that should get figures 1 and 2).
- If the fourth figure is not needed the figures are set to 0.

ID-labels are attached near sensor or near boreholes on cables or tubes. Double ID-labels are also attached on both ends of tubes and cables that will be dragged through the lead-through holes.

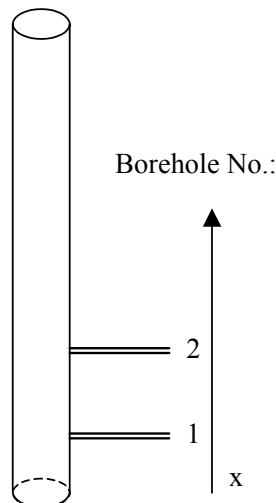
**TBM tunnel**



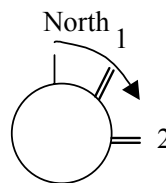
Section of tunnel (within appr 0.5 m of x) looking towards x=3600 m



**Borehole or Deposition hole**



Section of deposition hole (within appr 0.5 m of x) looking towards the bottom of the hole



Tunnel section I									
Mark	Borehole	Section Secup	Section Seclow	Tube type	Use of tube	Outer diameter	Tube length from borehole to Lead-through borehole in A-Tunnel (m)	Tube length in Lead-through borehole (m)	Tube length from Lead-through borehole to instrument panel in G-Tunnel (m)
PROA0140	KA3600F	1.3	18	PA	P	6	22	59	15
PROA0130	KA3600F	20	39.5	PA	P	6	22	59	15
PROA0120	KA3600F	40.5	42	PA	P	6	22	59	15
KROA0120	KA3600F	40.5	42	PE	HC	1/8"	22	59	15
PROA0110	KA3600F	43	50.1	PA	P	6	22	59	15
PROA0210	KA3597H01	0.65	2	PA	P	6	20	59	15
PROA0410	KA3597D01	0.65	2	PA	P	6	20	59	15
PROA0540	KA3593G	3	7	PA	P	6	15	59	15
FROA0540	KA3593G	3	7	PA	F	6	15	59	15
PROA0530	KA3593G	9	22.5	PA	P	6	15	59	15
PROA0520	KA3593G	23.5	24.2	PA	P	6	15	59	15
KROA0520	KA3593G	23.5	24.2	PE	HC	1/8"	15	59	15
PROA0510	KA3593G	25.2	30.02	PA	P	6	15	59	15
PROA0710	KA3592C01	0.65	2	PA	P	6	15	59	15
PROA0840	KA3590G02	1.3	9.9	PA	P	6	10	59	15
PROA0830	KA3590G02	11.9	13.2	PA	P	6	10	59	15
KROA0830	KA3590G02	11.9	13.2	PE	HC	1/8"	10	59	15
PROA0820	KA3590G02	15.2	23.5	PA	P	6	10	59	15
FROA0810	KA3590G02	25.5	30.01	PA	F	6	10	59	15
PROA0810	KA3590G02	25.5	30.01	PA	P	6	10	59	15
PROA0930	KA3590G01	1.3	6	PA	P	6	10	59	15
KROA0930	KA3590G01	1.3	6	PE	HC	1/8"	10	59	15
PROA0920	KA3590G01	7	15	PA	P	6	10	59	15
FROA0922	KA3590G01	7	15	PA	F	6	10	59	15
FROA0921	KA3590G01	7	15	PA	F	6	10	59	15
PROA0910	KA3590G01	16	30	PA	P	6	10	59	15
PROA1110	KA3588I01	0.65	2	PA	P	6	15	59	15
PROA1210	KA3588D01	0.65	2	PA	P	6	15	59	15
PROA1310	KA3588C01	0.65	2	PA	P	6	15	59	15
PROA1420	KA3584G01	1.3	5	PA	P	6	15	54	15
PROA1410	KA3584G01	7	12	PA	P	6	15	54	15
PROA1530	KA3579G	2.3	11.5	PA	P	6	15	54	15
PROA1520	KA3579G	12.5	13.7	PA	P	6	15	54	15
PROA1510	KA3579G	14.7	22.65	PA	P	6	15	54	15
PROA1610	KA3579D01	0.65	2	PA	P	6	15	54	15
PROA1710	KA3578H01	0.65	2	PA	P	6	15	54	15
PROA1920	KA3578G01	4.3	5.5	PA	P	6	15	54	15
KROA1920	KA3578G01	4.3	5.5	PE	HC	1/8"	15	54	15
PROA1910	KA3578G01	6.5	12.58	PA	P	6	15	54	15
PROA2010	KA3578C01	0.65	2	PA	P	6	15	54	15
PROA2230	KA3576G01	1.3	3	PA	P	6	15	54	15
PROA2220	KA3576G01	4	6	PA	P	6	15	54	15
KROA2220	KA3576G01	4	6	PE	HC	1/8"	15	54	15
PROA2210	KA3576G01	8	12.01	PA	P	6	15	54	15



Tunnel section I cont.									
Mark	Borehole	Section Secup	Section Seclow	Tube type	Use of tube	Outer diameter	Tube length from borehole to Lead-through borehole in A-Tunnel (m)	Tube length in Lead-through borehole (m)	Tube length from Lead-through borehole to instrument panel in G-Tunnel (m)
PROA2530	KA3574G01	1.8	4.1	PA	P	6	20	54	15
CROA2532	KA3574G01	1.8	4.1	PA	C	6	20	54	15
CROA2531	KA3574G01	1.8	4.1	PA	C	6	20	54	15
PROA2520	KA3574G01	5.1	7	PA	P	6	20	54	15
PROA2510	KA3574G01	8	12.03	PA	P	6	20	54	15
PROA2610	KA3574D01	0.65	2	PA	P	6	20	54	15
PROA2710	KA3573C01	0.65	2	PA	P	6	20	54	15
PROA2850	KA3573A	1.3	8.5	PA	P	6	20	54	15
PROA2840	KA3573A	10.5	12.5	PA	P	6	20	54	15
FROA2840	KA3573A	10.5	12.5	PA	F	6	20	54	15
PROA2830	KA3573A	14.5	19	PA	P	6	20	54	15
PROA2820	KA3573A	21	24	PA	P	6	20	54	15
FROA2820	KA3573A	21	24	PA	F	6	20	54	15
PROA2810	KA3573A	26	40.07	PA	P	6	20	54	15
PROA2920	KA3572G01	2.7	5.3	PA	P	6	15	47	15
CROA2922	KA3572G01	2.7	5.3	PA	C	6	15	47	15
CROA2921	KA3572G01	2.7	5.3	PA	C	6	15	47	15
PROA2910	KA3572G01	7.3	12.03	PA	P	6	15	47	15
PROA3110	KA3568D01	0.65	2	PA	P	6	15	47	15
PROA3250	KA3566G02	1.3	6	PA	P	6	15	47	15
FROA3250	KA3566G02	1.3	6	PA	F	6	15	47	15
PROA3240	KA3566G02	8	11	PA	P	6	15	47	15
PROA3230	KA3566G02	12	14	PA	P	6	15	47	15
PROA3220	KA3566G02	16	18	PA	P	6	15	47	15
CROA3222	KA3566G02	16	18	PA	C	6	15	47	15
CROA3221	KA3566G02	16	18	PA	C	6	15	47	15
PROA3210	KA3566G02	19	30.01	PA	P	6	15	47	15
PROA3350	KA3566G01	1.5	6.3	PA	P	6	15	47	15
FROA3350	KA3566G01	1.5	6.3	PA	F	6	15	47	15
PROA3340	KA3566G01	7.3	10	PA	P	6	15	47	15
PROA3330	KA3566G01	12	18	PA	P	6	15	47	15
PROA3320	KA3566G01	20	21.5	PA	P	6	15	47	15
CROA3322	KA3566G01	20	21.5	PA	C	6	15	47	15
CROA3321	KA3566G01	20	21.5	PA	C	6	15	47	15
PROA3310	KA3566G01	23.5	30.01	PA	P	6	15	47	15
PROA3410	KA3566C01	0.65	2	PA	P	6	15	47	15
PROA3510	KA3563I01	0.65	2	PA	P	6	20	47	15
PROA3640	KA3563G	1.5	3	PA	P	6	20	47	15
CROA3642	KA3563G	1.5	3	PA	C	6	20	47	15
CROA3641	KA3563G	1.5	3	PA	C	6	20	47	15
PROA3630	KA3563G	4	8	PA	P	6	20	47	15
PROA3620	KA3563G	10	13	PA	P	6	20	47	15
PROA3610	KA3563G	15	30.01	PA	P	6	20	47	15
PROA3710	KA3563D01	0.65	2	PA	P	6	20	47	15
PROA3810	KA3563A01	0.65	2	PA	P	6	20	47	15

Tunnel section II									
Mark	Borehole	Section Secup	Section Seclow	Tube type, Lead-through holes	Use of tube	Outer diameter	Tube length from borehole to Lead-through borehole in A-Tunnel (m)	Tube length in Lead-through borehole (m)	Tube length from Lead-through borehole to instrument panel in G-Tunnel (m)
XRA1100	KA3539G	0	30	PA	X	6	10	35	25
PRA1110	KA3539G	18.6	30	PA	P	6	10	35	25
CRA1121	KA3539G	15.85	17.6	PA	C	6	10	35	25
CRA1122	KA3539G	15.85	17.6	PA	C	6	10	35	25
HRA1121	KA3539G	15.85	17.6	PA	H	10	10	35	15
HRA1122	KA3539G	15.85	17.6	PA	H	10	10	35	15
PRA1120	KA3539G	15.85	17.6	PA	P	6	10	35	25
FRA1130	KA3539G	10	14.85	PA	F	6	10	35	25
PRA1130	KA3539G	10	14.85	PA	P	6	10	35	25
PRA1140	KA3539G	4	9	PA	P	6	10	35	25
XRA1200	KA3542G01	0	30	PA	X	6	10	35	25
PRA1210	KA3542G01	27	30	PA	P	6	10	35	25
PRA1220	KA3542G01	21.3	26	PA	P	6	10	35	25
CRA1231	KA3542G01	18.6	20.3	PA	C	6	10	35	25
CRA1232	KA3542G01	18.6	20.3	PA	C	6	10	35	25
HRA1231	KA3542G01	18.6	20.3	PA	H	10	10	35	15
HRA1232	KA3542G01	18.6	20.3	PA	H	10	10	35	15
PRA1230	KA3542G01	18.6	20.3	PA	P	6	10	35	25
PRA1240	KA3542G01	10.5	17.6	PA	P	6	10	35	25
PRA1250	KA3542G01	3.5	9.5	PA	P	6	10	35	25
XRA1300	KA3542G02	0	30	PA	X	6	10	35	25
PRA1310	KA3542G02	28.2	30.01	PA	P	6	10	35	25
CRA1321	KA3542G02	25.6	27.2	PA	C	6	10	35	25
CRA1322	KA3542G02	25.6	27.2	PA	C	6	10	35	25
HRA1321	KA3542G02	25.6	27.2	PA	H	10	10	35	15
HRA1322	KA3542G02	25.6	27.2	PA	H	10	10	35	15
PRA1320	KA3542G02	25.6	27.2	PA	P	6	10	35	25
PRA1330	KA3542G02	21.5	24.6	PA	P	6	10	35	25
PRA1340	KA3542G02	9	20.5	PA	P	6	10	35	25
FRA1350	KA3542G02	2	8	PA	F	6	10	35	25
PRA1350	KA3542G02	2	8	PA	P	6	10	35	25
PRA1410	KA3543A01	0.65	2	PA	P	6	10	35	25
PRA1510	KA3543I01	0.65	2	PA	P	6	10	35	25
XRA1600	KA3544G01	0	12	PA	X	6	10	35	25
PRA1610	KA3544G01	11.65	12	PA	P	6	10	35	25
CRA1621	KA3544G01	8.9	10.65	PA	C	6	10	35	25
CRA1622	KA3544G01	8.9	10.65	PA	C	6	10	35	25
HRA1621	KA3544G01	8.9	10.65	PA	H	10	10	35	15
HRA1622	KA3544G01	8.9	10.65	PA	H	10	10	35	15
PRA1620	KA3544G01	8.9	10.65	PA	P	6	10	35	25
PRA1630	KA3544G01	3.5	7.9	PA	P	6	10	35	25
XRA1700	KA3546G01	0	12	PA	X	6	10	35	25
PRA1710	KA3546G01	9.3	12	PA	P	6	10	35	25
CRA1721	KA3546G01	6.75	8.3	PA	C	6	10	35	25
CRA1722	KA3546G01	6.75	8.3	PA	C	6	10	35	25
HRA1721	KA3546G01	6.75	8.3	PA	H	10	10	35	15
HRA1722	KA3546G01	6.75	8.3	PA	H	10	10	35	15
PRA1720	KA3546G01	6.75	8.3	PA	P	6	10	35	25
PRA1730	KA3546G01	1.5	5.75	PA	P	6	10	35	25
XRA1800	KA3548A01	0	30	PA	X	6	10	35	25
PRA1810	KA3548A01	21.5	30	PA	P	6	10	35	25
FRA1820	KA3548A01	11.75	20.5	PA	F	6	10	35	25
PRA1820	KA3548A01	11.75	20.5	PA	P	6	10	35	25
CRA1831	KA3548A01	8.8	10.75	PA	C	6	10	35	25
CRA1832	KA3548A01	8.8	10.75	PA	C	6	10	35	25
HRA1831	KA3548A01	8.8	10.75	PA	H	10	10	35	15
HRA1832	KA3548A01	8.8	10.75	PA	H	10	10	35	15
PRA1830	KA3548A01	8.8	10.75	PA	P	6	10	35	25
PRA1840	KA3548A01	3	7.8	PA	P	6	10	35	25

Tunnel section II cont.									
Mark	Borehole	Section Secup	Section Seclow	Tube type, Lead-through holes	Use of tube	Outer diameter	Tube length from borehole to Lead-through borehole in A-Tunnel (m)	Tube length in Lead-through borehole (m)	Tube length from Lead-through borehole to instrument panel in G-Tunnel (m)
PRA1910	KA3548D01	0.65	2	PA	P	6	10	35	25
XRA2000	KA3548G01	0	12	PA	X	6	10	35	25
PRA2010	KA3548G01	6	12	PA	P	6	10	35	25
PRA2020	KA3548G01	2	5	PA	P	6	10	35	25
XRA2100	KA3550G01	0	12.03	PA	X	6	10	35	25
PRA2110	KA3550G01	8.3	12.03	PA	P	6	10	35	25
CRA2121	KA3550G01	5.2	7.3	PA	C	6	10	35	25
CRA2122	KA3550G01	5.2	7.3	PA	C	6	10	35	25
HRA2121	KA3550G01	5.2	7.3	PA	H	10	10	35	15
HRA2122	KA3550G01	5.2	7.3	PA	H	10	10	35	15
PRA2120	KA3550G01	5.2	7.3	PA	P	6	10	35	25
PRA2130	KA3550G01	1.8	4.2	PA	P	6	10	35	25
XRA2200	KA3550G05	0	3	PA	X	6	10	35	25
PRA2210	KA3550G05	1.5	3	PA	P	6	10	35	25
XRA2300	KA3551G05	0	3.1	PA	X	6	10	35	25
PRA2310	KA3551G05	1.5	3.1	PA	P	6	10	35	25
PRA2410	KA3552A01	0.65	2	PA	P	6	10	35	25
XRA2500	KA3552G01	0	12	PA	X	6	10	35	25
PRA2510	KA3552G01	7.05	12	PA	P	6	10	35	25
CRA2521	KA3552G01	4.35	6.05	PA	C	6	10	35	25
CRA2522	KA3552G01	4.35	6.05	PA	C	6	10	35	25
HRA2521	KA3552G01	4.35	6.05	PA	H	10	10	35	15
HRA2522	KA3552G01	4.35	6.05	PA	H	10	10	35	15
PRA2520	KA3552G01	4.35	6.05	PA	P	6	10	35	25
PRA2530	KA3552G01	1.5	3.35	PA	P	6	10	35	25
PRA2610	KA3552H01	0.65	2	PA	P	6	10	35	25
PRA2710	KA3553B01	0.65	2	PA	P	6	10	35	25
XRA2800	KA3554G01	0	30.01	PA	X	6	10	35	25
PRA2810	KA3554G01	25.15	30.01	PA	P	6	10	35	25
CRA2821	KA3554G01	22.6	24.15	PA	C	6	10	35	25
CRA2822	KA3554G01	22.6	24.15	PA	C	6	10	35	25
HRA2821	KA3554G01	22.6	24.15	PA	H	10	10	35	15
HRA2822	KA3554G01	22.6	24.15	PA	H	10	10	35	15
PRA2820	KA3554G01	22.6	24.15	PA	P	6	10	35	25
PRA2830	KA3554G01	14	21.6	PA	P	6	10	35	25
PRA2840	KA3554G01	5	13	PA	P	6	10	35	25
PRA2850	KA3554G01	1.5	4	PA	P	6	10	35	25
XRA2900	KA3554G02	0	30.01	PA	X	6	10	35	25
PRA2910	KA3554G02	22	30.01	PA	P	6	10	35	25
PRA2920	KA3554G02	15.9	21	PA	P	6	10	35	25
PRA2930	KA3554G02	13.2	14.9	PA	P	6	10	35	25
CRA2941	KA3554G02	10.5	12.2	PA	C	6	10	35	25
CRA2942	KA3554G02	10.5	12.2	PA	C	6	10	35	25
HRA2941	KA3554G02	10.5	12.2	PA	H	10	10	35	15
HRA2942	KA3554G02	10.5	12.2	PA	H	10	10	35	15
PRA2940	KA3554G02	10.5	12.2	PA	P	6	10	35	25
PRA2950	KA3554G02	1.5	9.5	PA	P	6	10	35	25
XRA3000	KA3557G	0	30.04	PA	X	6	10	35	25
PRA3010	KA3557G	15	30.04	PA	P	6	10	35	25
PRA3020	KA3557G	1.5	14	PA	P	6	10	35	25