

**International  
Progress Report**

**IPR-03-04**

# **Äspö Hard Rock Laboratory**

## **Äspö Pillar Stability Experiment**

### **Coupled 3D thermo-mechanical modelling. Preliminary results**

Toivo Wanne

Erik Johansson

Consulting Engineers Saanio & Riekkola

March 2003

**Svensk Kärnbränslehantering AB**

Swedish Nuclear Fuel

and Waste Management Co

Box 5864

SE-102 40 Stockholm Sweden

Tel +46 8 459 84 00

Fax +46 8 661 57 19



**Äspö Hard Rock  
Laboratory**



Report no.	No.
IPR-03-04	F86K
Author	Date
Toivo Wanne	March 2003
Erik Johansson	
Checked by	Date
Christer Andersson	2003-04-02
Derek Martin	
Approved	Date
Christer Svemar	2003-05-22

# **Äspö Hard Rock Laboratory**

## **Äspö Pillar Stability Experiment**

### **Coupled 3D thermo-mechanical modelling. Preliminary results**

Toivo Wanne

Erik Johansson

Consulting Engineers Saanio & Riekkola

March 2003

*Keywords:* Coupled thermo-mechanical modelling, FLAC3D, nuclear waste disposal, pillar stability, rock heating, temperature-induced stress, Äspö HRL

This report concerns a study which was conducted for SKB. The conclusions and viewpoints presented in the report are those of the author(s) and do not necessarily coincide with those of the client.



## Abstract

SKB is planning to perform a large-scale pillar stability experiment called APSE (Äspö Pillar Stability Experiment) at Äspö HRL. The study is focused on understanding and control of progressive rock failure in a pillar and damage caused by high stresses.

The experiment is modeled by different groups using different methods. The modeling of the experiment presented in this document describes the first phase of the modeling work, the thermal and mechanical modeling carried out by Saanio & Riekkola Oy. The modeling is carried out in three dimensions by using FLAC3D software.

Two different model geometries were used in modeling, one with slots and one without. Both cases were modeled using three different in-situ stress states. A sensitivity study of the effect of changes in thermal conductivity and Young's modulus values on the stresses was carried out as part of the work.

The modeling results showed that the stress increase caused by the excavation of the slots is about 10-20 MPa depending on the location in the pillar. The heating of the rock induces stress increase in the pillar area and after 120 days of heating the stress increase is approximately 40% higher than the pre-heating stress state at the hole wall. The crack initiation stress of the host rock is exceeded at the top of the pillar area in each of the several modeling cases. The crack damage stress and the peak strength are exceeded after 120 days heating in every in-situ stress state case with slots at the hole wall.

The sensitivity analyses showed that increase of 15% of the thermal conductivity of the rock causes a stress decrease of 4%. When the modulus value is increased by 45% the stresses increase 13%. This holds only for thermo-mechanical calculations



# Sammanfattning

SKB planerar att utföra ett omfattande experiment benämnt APSE (Äspö Pillar Stability Experiment) vid Äspölaboratoriet. Studien fokuserar på förståelse och kontroll av progressiva brott orsakade av höga spänningar i en bergpelare.

Numerisk modellering av experimentet har genomförts av grupper som använt olika dataprogram. Modelleringen av experimentet som presenteras i detta dokument beskriver modelleringsarbetets första fas, den termiska och mekaniska modelleringen genomförd av Saanio & Riekkola Oy. Genom användandet av mjukvaran FLAC3D har modelleringen kunnat utföras i tre dimensioner.

Två olika modellgeometrier användes för modelleringen, en med slitsar och en utan. Vid modelleringen användes i båda fallen tre olika spänningstillstånd. En känslighetsstudie rörande effekten av förändringar i termisk ledningsförmåga utfördes, och som en del av det arbetet undersöktes elasticitetsmodulens inverkan på den termiskt inducerade spänningen.

Modelleringsresultaten påvisade att den av slitsarna inducerade spänningsökningen är ca 10-20 MPa beroende på slitsarnas utformning. Vid uppvärmningen av berget induceras en spänningsökning i pelaren och efter 120 dagars uppvärmning har spänningen, jämfört med före uppvärmningen, ökat med ca 40 %. Lasten för sprickinitiering överskrider i den övre delen av pelaren vid alla de olika realiseringarna. Sprickskador orsakade av laster som överskrider det intakta bergets hållfasthet sker efter 120 dagars uppvärmning vid samtliga lastfall där slitsar i hålväggarna inkorporerats i modellen.

Känslighetsanalyserna påvisade att en ökning av termisk ledningsförmåga på 15 % orsakar en lastminskning på 4 %. Då elasticitetsmodulens värde ökar med 45 % ökar lasten med 13 %. E-modulens värde påverkar endast termomekaniska beräkningar.





# Contents

<b>1</b>	<b>Introduction</b>	<b>9</b>
<b>2</b>	<b>Modeling</b>	<b>11</b>
2.1	Tool	11
2.2	Mechanical material properties	11
2.3	Model set-up	12
2.4	Thermal properties	13
2.5	Initial stresses	15
<b>3</b>	<b>Results of thermal - mechanical modeling</b>	<b>17</b>
3.1	Temperatures	18
3.2	Stress state 1 (25, 15, 10 MPa) with slots	20
3.3	Stress state 2 (30, 15, 10 MPa) with slots	22
3.4	Stress state 3 (35, 15, 10 MPa) with slots	23
3.5	Stress state 1 (25, 15, 10 MPa) without slots	24
3.6	Stress state 2 (30, 15, 10 MPa) without slots	27
3.7	Stress state 3 (35, 15, 10 MPa) without slots	28
3.8	Sensitivity analyses	29
<b>4</b>	<b>Comparison Slot - No slot</b>	<b>33</b>
<b>5</b>	<b>Summary</b>	<b>35</b>
<b>6</b>	<b>References</b>	<b>39</b>
<b>7</b>	<b>List of appendices</b>	<b>41</b>
<b>8</b>	<b>Appendix A: temperature profile plots from APSE thermal-mechanical simulation.</b>	<b>43</b>
8.1	Temperature profiles at level 0.5m below the tunnel floor	44
8.2	Temperature profiles at level 1.5m below the tunnel floor	46
<b>9</b>	<b>Appendix B: Stress profile plots from APSE thermal-mechanical simulation.</b>	<b>49</b>
9.1	MODEL WITH SLOTS	50
9.2	MODEL WITHOUT SLOTS	56



# 1 Introduction

SKB is preparing to perform a large-scale pillar stability experiment at Äspö HRL (Andersson 2003). APSE (Äspö Pillar Stability Experiment) will study pillar stability and damage caused by high temperature-induced stresses. The objectives are set by SKB:

1. Demonstrate the capability to predict spalling in a fractured rock mass,
2. Demonstrate the effect of backfill (confining pressure) on the rock mass response,
3. Comparison of 2D and 3D mechanical and thermal predicting capabilities.

The pre-test modeling supports technical feasibility study of the planned test. The modeling was carried out in three dimensions because of the complex test geometry and in-situ stresses by using a finite-difference modeling program FLAC3D (Itasca 2002).

This report describes the preliminary thermal and mechanical modeling of the pillar experiment by using FLAC3D software. Input data for modeling was submitted by SKB.

Chapter 2 presents the modeling properties. Section 3.1 presents temperature related results and Sections 3.2 to 3.4 present temperature-induced stresses after 120 days with slots and Sections 3.5 to 3.7 present temperature-induced stresses after 120 days without slots. Section 3.8 presents the sensitivity analysis results. Chapter 4 compares results obtained with and without slots and Chapter 5 summarizes FLAC3D thermal-mechanical modeling results.



## 2 Modeling

### 2.1 Tool

The thermal and mechanical modeling computations were performed using Itasca’s FLAC3D software (Itasca 2002). FLAC3D is a three-dimensional explicit finite-difference program for engineering mechanics computation. Software simulates the behavior of three-dimensional structures built of soil, rock or other materials that undergo plastic flow when their yield-limits are reached. The geometry is modeled by using polyhedral elements within a three-dimensional grid that is adjusted to fit the shape of the object to be modeled.

Elastic mechanical model was used in this study. The thermal model simulates the transient flux of heat in materials and the subsequent development of thermally-induced stresses. The thermal-mechanical coupling is one-way; temperature change may induce a mechanical stress, however mechanical changes in the body do not result temperature change. Software contains also a powerful built-in programming language, *FISH*, which enables individual tailoring the analyses to suit specific needs.

### 2.2 Mechanical material properties

The properties describe Äspö diorite which is considered the main rock type in the experimental area.

Material model used in FLAC3D simulations was elastic. Young’s modulus and Poisson’s ratio values were needed for defining the material. Table 2-1 lists the used material properties in a basic modeling case. Some sensitivity analyses were made concerning the deformation parameters and the corresponding properties are listed in *Section 3.8 Sensitivity analyses*.

The unconfined strength of the rock is 219 MPa, the crack damage stress 190 MPa, the crack initiation stress 118 MPa (Nordlund et al. 1999) and the tensile strength 14.8 MPa (Janson et al. 2003). These values were not used in the actual modeling but in some extent in the interpretation of the results.

**Table 2-1. Mechanical material properties of Äspö diorite for modeling the basic case.**

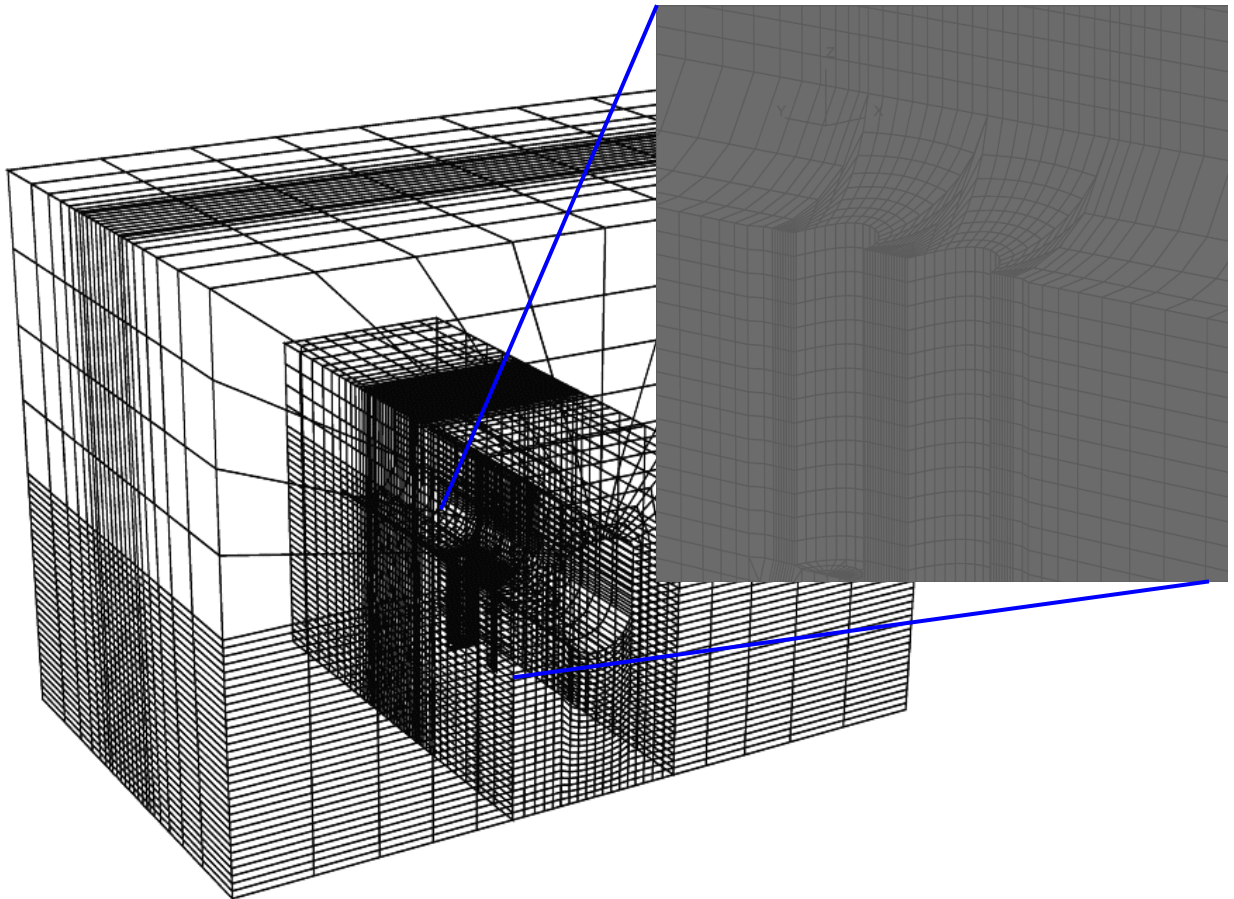
Young’s modulus, E [GPa]	Poisson’s ratio, $\nu$	Bulk modulus, K [GPa]	Shear modulus, G [GPa]
<b>68,0</b>	<b>0,24</b>	<b>43.6</b> eq. (1)	<b>27.4</b> eq. (2)

$$(1) \quad K = \frac{E}{3(1-2\nu)}$$

$$(2) \quad G = \frac{E}{2(1+\nu)}$$

### 2.3 Model set-up

The model geometry is created as a grid in a global x, y, z-coordinate system. The model geometry is assembled by using a library of primitive shapes and putting them together. The more complex geometries are achieved by modifying the basic shapes with *FISH*. The APSE model is constructed by attaching ten primitive shapes of three different kinds and then reflecting those. The floor curvature and the slots are made with the help of *FISH*. The model is 50 m wide, 37 m high, and 30 m in length. The tunnel is oval-shaped with width of 5 m and the height of 7.5m. The 1.8 m diameter disposal holes are situated on the tunnel floor in the middle of the model. The model has about 52000 gridpoints and 48000 zones. Two models were built one with the slots and one without. The model grid with slots is shown in Figure 2-1.



*Figure 2-1. Sketch of the whole FLAC3D model and magnification of a half section around the pillar area.*

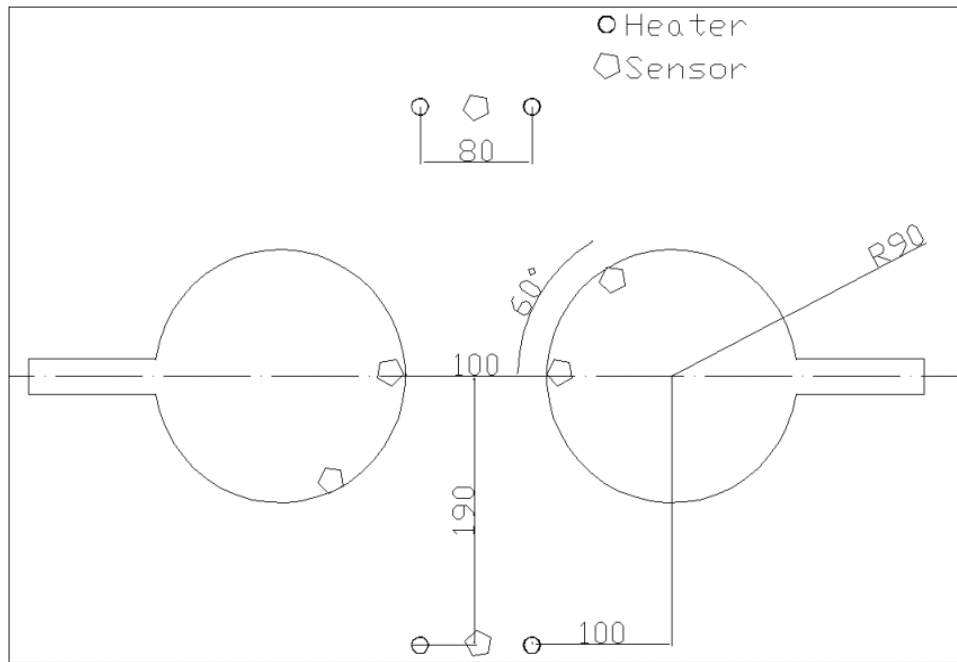
## 2.4 Thermal properties

Thermal properties dictate the thermal response of the model to the heat that is put to a model. The properties are given to rock material by SKB and water. The other disposal hole is filled with water (for pressurizing purpose) and the model will take account for the temperature decreasing effect of the water near the disposal hole. The used thermal properties for basic cases are listed in Table 2-2. Some sensitivity analyses were made concerning the conductivity and the corresponding properties are listed in *Section 3.8 Sensitivity analyses*. Formulation for the thermal calculation in FLAC3D can be found in the software manuals for details (Itasca 2002).

**Table 2-2. Thermal properties for modeling the basic case, rock (above) and water (below).**

Density, $\rho$ [kg/m <sup>3</sup> ]	Conductivity, K [W/m, K]	Heat capacity, [MJ/m <sup>3</sup> , K]	Linear exp. coeff., $\alpha_t$ [1/°C]
<b>2710</b>	<b>2.83</b>	<b>2.1</b>	<b>7.9*10<sup>-6</sup></b>
Specific heat, $C_v$ [J/kg, K]	<b>775</b>	Initial temperature [°C]	<b>15.0</b>
Density, $\rho$ [kg/m <sup>3</sup> ]	Conductivity, K [W/m, K]	Heat capacity, [MJ/m <sup>3</sup> , K]	
<b>1000</b>	<b>0.60</b>	<b>4.18</b>	
Specific heat, $C_v$ [J/kg, K]	<b>4180</b>	Initial temperature [°C]	<b>15.0</b>

The model is heated with four heaters. The heater layout and effect design is presented in Fredriksson et al. (2003). Heater layout is shown in the Figure 2-2. The heater holes are 0.5 m deeper than the deposition holes (depth 6.0 m). The temperature history points are located on the tunnel floor and every 0.5 meters below the lowest floor level until 0.5 meters below deposition hole bottom. Four history point arrays are located at the disposal hole surfaces and two arrays between the heaters. This totals 90 temperature history points.



**Figure 2-2.** Heaters, temperature sensors and deposition holes. Heater power is 200 W/m. The diameter of the holes is 1.8 meters.

Heater effect is set to be 200 W/m. Hence each of the four heaters has an effect of 1300 W (=6.5 m x 200 W/m). The heaters are installed in FLAC3D by using the built-in programming language *FISH*. The heaters could be simulated in two different ways, as a point source or a volume source. The volume source approach was chosen as it was thought to resemble a heater array more realistically than the point source. The point source is considered to resemble a spherical heat source and the volume source a cylindrical heat source.

For comparison a small test model was built and both approaches were tested. The heat effect in a certain distance from the source was similar. The difference between the two was that the point source heater warmed up more than the volume source heater. For this modeling purpose the volume heater was found to be easier to use.

The volume source heater was installed by first defining a range of modeling zones in the model that would become a heater. The range was given by defining volume which is enclosed by given coordinate ranges. A *FISH*-function calculates the exact volume [m<sup>3</sup>] of the heater then applies volume heat source [W/m<sup>3</sup>] to that volume that is equivalent to a line heater with given effect [W/m].

By default all the boundaries and free surfaces in the model are adiabatic i.e. fully insulated. Convection of the heat to the tunnel air was not included in the modeling. The wall of the other hole was considered to be completely insulated. On the other hand the other hole was filled with water which stored some of the heat.



## 2.5 Initial stresses

The model is submitted to an in-situ stress state that is thought to exist in the actual underground test facility. The tunnel is oriented to be perpendicular to the maximum principal in-situ stress,  $\sigma_1$ . The two other stress components then follow with their relative orientations. Table 2-3 shows the in-situ stress states used (Janson et al. 2003). The measured orientation values have to be slightly modified to meet the orthogonal requirement of the principal stresses. Thus, the used stress trends are 310, 090 and 208 degrees for the three principal stresses, respectively. The modeling was performed using three different stress values for the major principal stress. The stresses were applied to the model as boundary conditions and also as installed initial stresses in every zone. Before the actual modeling the model was solved to equilibrium under the given boundary and initial conditions. Gravity was not included in the modeling.

**Table 2-3. Initial stresses for modeling.**

	Magnitude [MPa]	Orientation [trend/dip]
$\sigma_1$	<b>25, 30, 35</b>	<b>310/30*</b>
$\sigma_2$	<b>15</b>	<b>082/53</b>
$\sigma_3$	<b>10</b>	<b>210/20</b>

\*Perpendicular to the tunnel axis



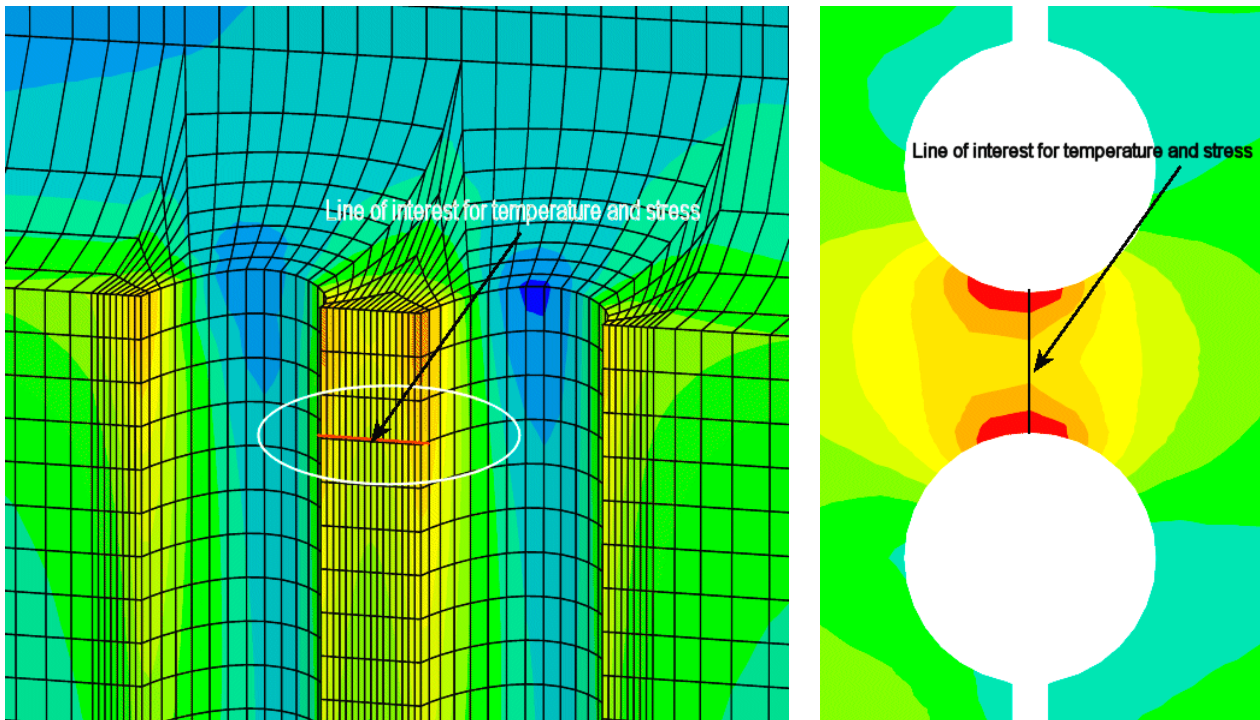
### 3 Results of thermal - mechanical modeling

The modeling was carried out using three different in-situ stress states and with two different geometries, slots and no slots. Each simulation was performed so that it produced results after 30, 60, 90, and 120 days of heating. The first instance were thermal-only simulations and the second were with thermal-mechanical coupling. This totals 48 simulation save files and 3800Mb of saved information. Table 3-1 lists all the calculations.

**Table 3-1. List of the modeling cases made in APSE project Phase 1.**

In-situ stress state $\sigma_1, \sigma_3, \sigma_3$	Geometry	
	With slots	Without slots
State 1: 25,15,10	X	X
State 2: 30,15,10	X	X
State 3: 35,15,10	X	X

From each simulation temperatures and maximum stresses in a center horizontal line between the holes at two levels are presented in graphs. The horizontal levels are 0.5 m and 1.5 m below the tunnel floor from the lowest point. The figure 3-1 shows the schematic view of the line of interest.

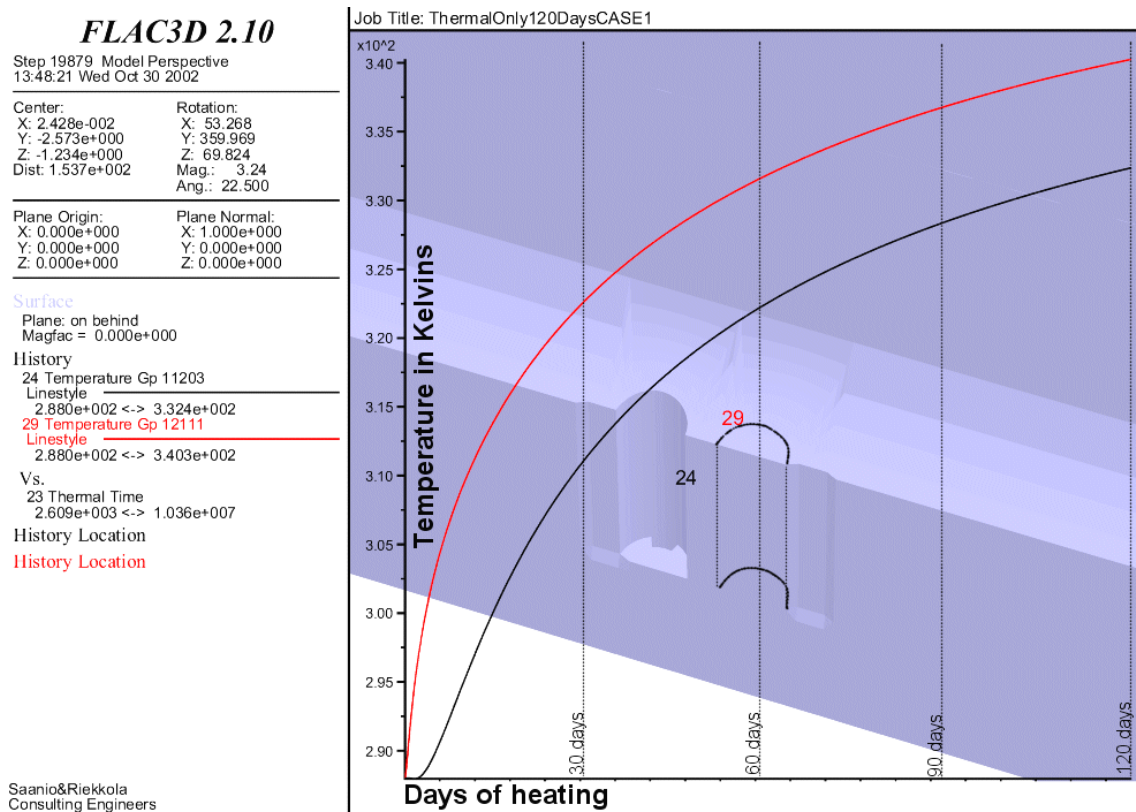


**Figure 3-1.** Schematic view of the line for temperature and stress on a vertical section (left) and on a horizontal section (right) 1.5 m below the tunnel floor.

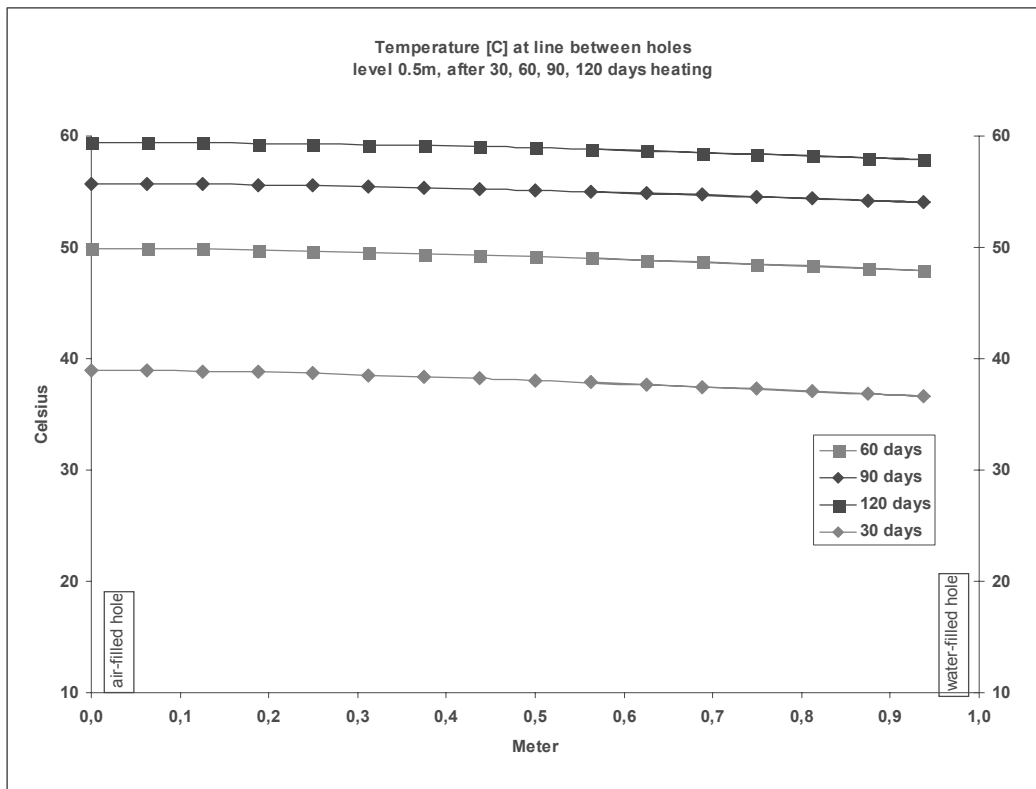
Appendix A contains collection of temperature profile plots and appendix B contains collection of stress profile plots from the simulation. Stress profiles are presented for the level 1.5 m below the tunnel floor. First are shown the plots from simulations with slots then same plots from simulation without slots.

### 3.1 Temperatures

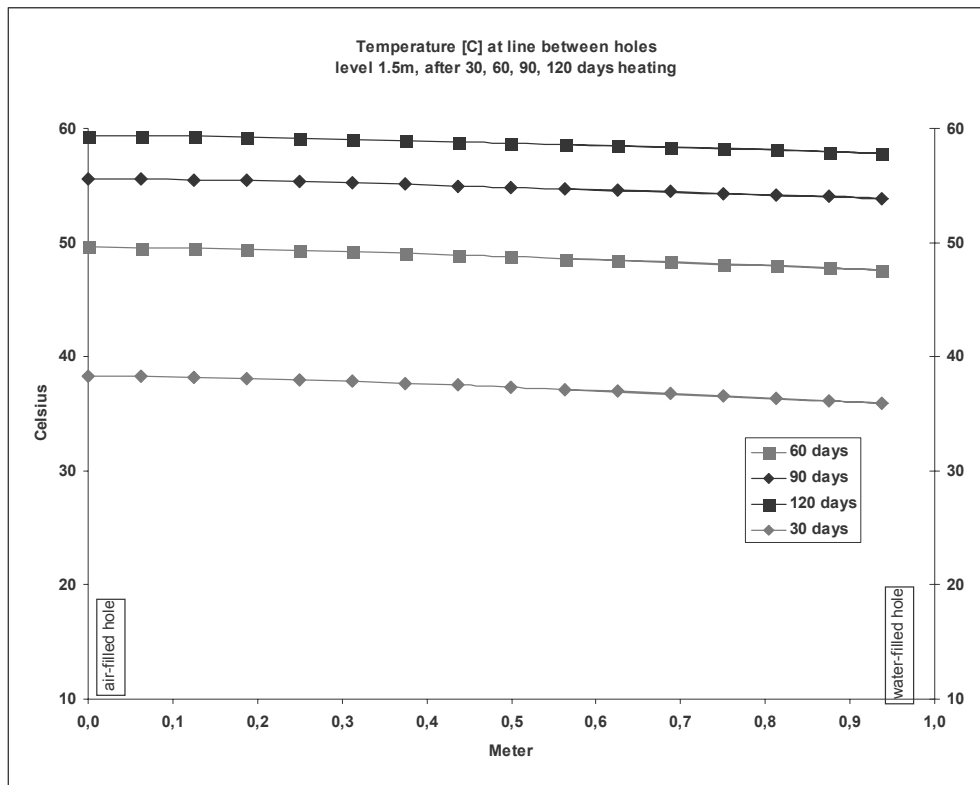
The in-situ stress state does not affect the thermal calculations hence the temperature increase is the same in every case. The temperature was monitored during the heating period in various locations. Figure 3-2 shows the temperatures in two different positions one being between the heaters and the other one being at a wall of the empty disposal hole at the level of 1.5 m below the tunnel floor during 120 days of heating. The temperature at the hole wall after 120 days is 59°C (332 K) and between the heaters 67°C (340 K). Figures 3-3 and 3-4 show the temperature profiles between the holes after 30, 60, 90, and 120 days of heating at the two levels (0.5 m and 1.5 m below the tunnel floor).



**Figure 3-2.** Temperature [in Kelvins] in vertical axis during heating. Lower line shows temperature at the hole wall (history point 24) and the upper line between the heaters (history point 29). Both are at the level of 1.5 m below the tunnel floor. The horizontal axis in days.



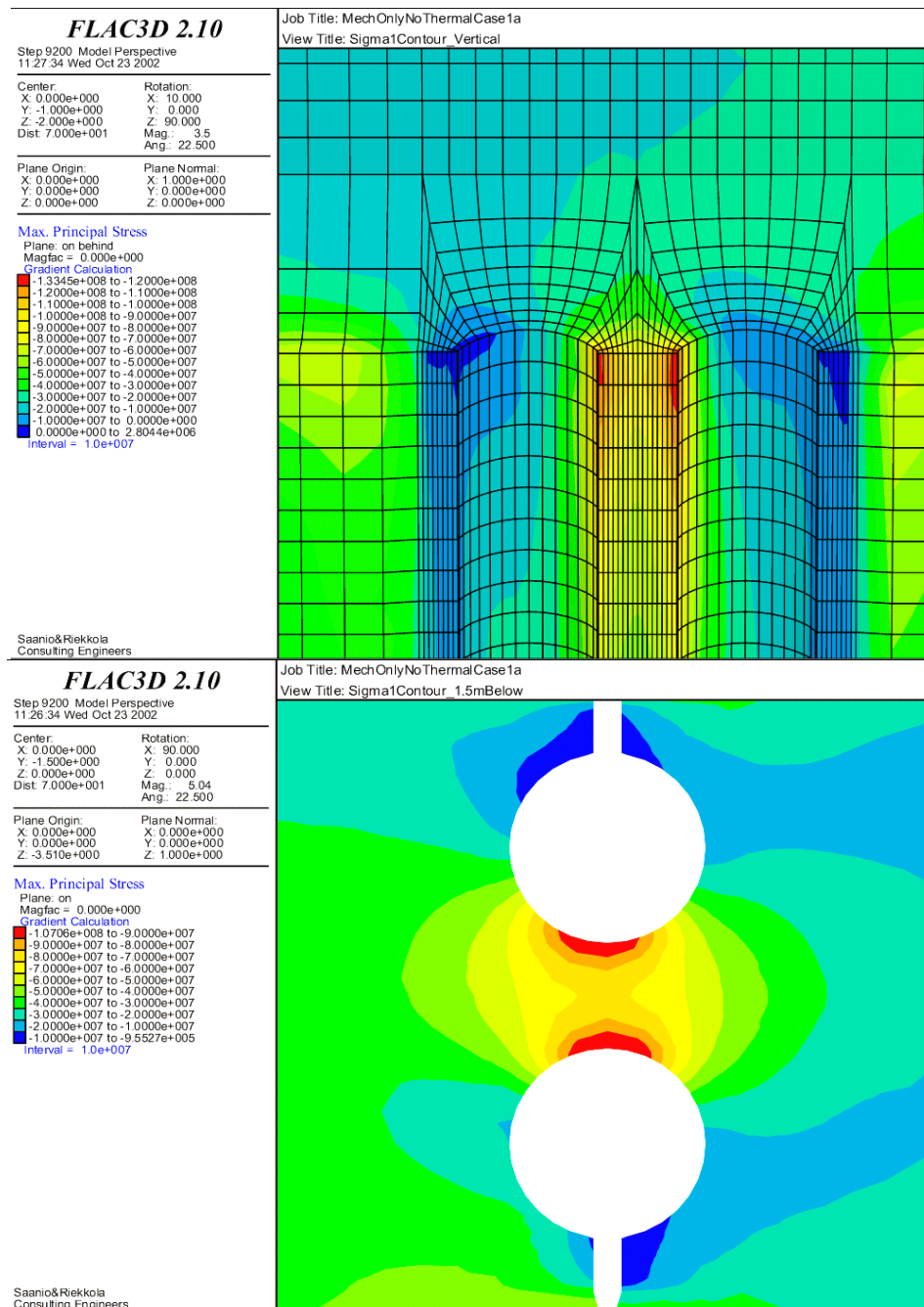
**Figure 3-3.** Temperature profiles after 30, 60, 90, and 120 days of heating at the level 0.5 m below the tunnel floor. Vertical axis spans from 10 to 60 degrees in Celsius. Horizontal axis from air-filled to water-filled hole in meters.



**Figure 3-4.** Temperature profiles after 30, 60, 90, and 120 days of heating at the level 1.5 m below the tunnel floor. Vertical axis spans from 10 to 60 degrees in Celsius. Horizontal axis from air-filled to water-filled hole in meters.

### 3.2 Stress state 1 (25, 15, 10 MPa) with slots

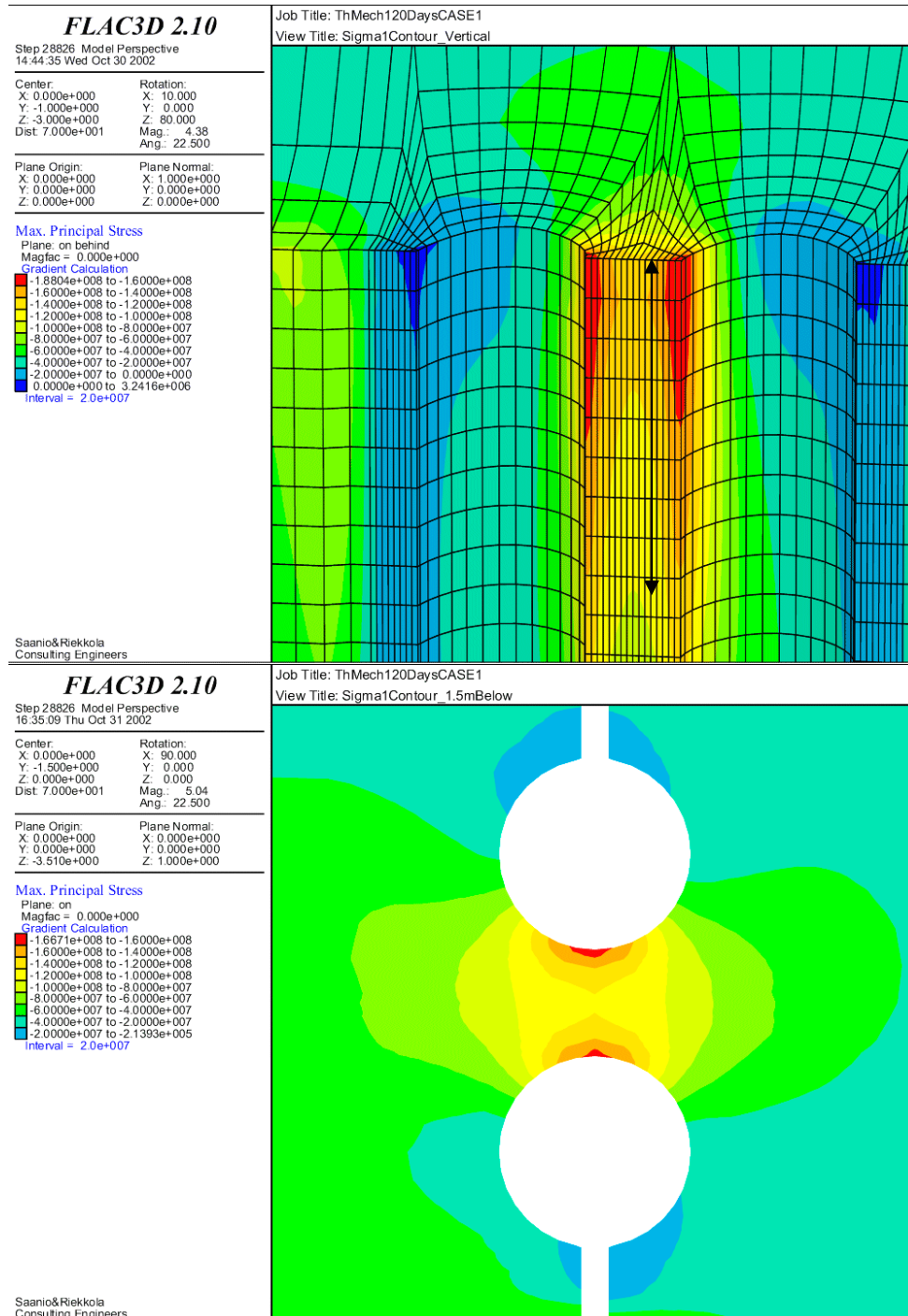
Stresses at the pillar area before heating are quite high. The in-situ stress state is greatly affected by the complex excavation geometry and the induced stresses around the area of interest are shown in Figure 3-5. The maximum stresses in mid-pillar at the level of 1.5 m below the floor are about 75 MPa. Maximum stresses at the top of the pillar are about 130 MPa which exceeds the crack initiation stress (118 MPa). The tensile strength (14.8 MPa) is exceeded in the hole walls 90 degrees from the slots. (Refer also to Figure 4-3 for comparison of tensile areas between model with and without slots after heating).



**Figure 3-5.** Model with slots and no thermal load. Maximum principal stresses at the pillar area. Vertical line spacing at the pillar is about 0.5 m. Model with slots and no thermal load. Upper section is vertical and aligned along the tunnel axis. The lower section is horizontal at a depth of 1.5 m below the tunnel floor.



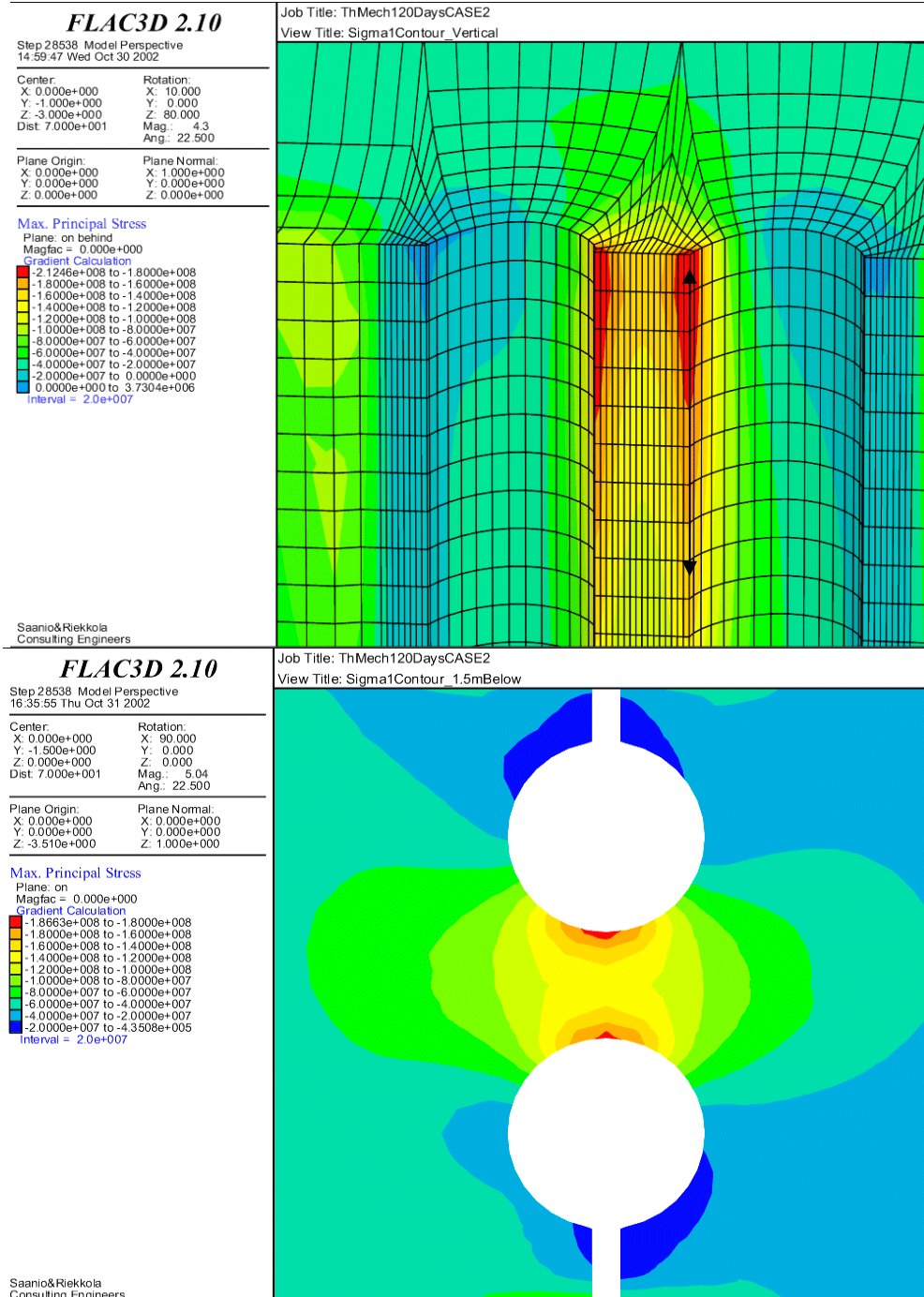
The heating increases the stresses at the upper pillar area significantly. After 120 days of heating the stress increase in mid-pillar at the level of 1.5 m below the floor is about 40 MPa. Maximum stresses at the top of the pillar are about 190 MPa (close to crack damage stress) compared to 130 MPa without heating. Figure 3-6 shows maximum stress contours on a vertical section of the model and at the horizontal section 1.5 m below the floor.



**Figure 3-6.** Model with slots and thermal load. Maximum principal stresses at the pillar area. At the first 4 meters (black arrow) of the pillar the stresses are over 140 MPa. Vertical line spacing at the pillar is about 0.5 m. Model with slots. Upper section is vertical and aligned along the tunnel axis. The lower section is horizontal at a depth of 1.5 m below the tunnel floor.

### 3.3 Stress state 2 (30, 15, 10 MPa) with slots

After 120 days of heating the stresses in mid-pillar at the level of 1.5 m below the floor are about 130 MPa. A maximum stress at the top of the pillar is about 210 MPa which is close to the peak strength of the rock. Figure 3-7 shows maximum stress contours on a vertical section of the model and at the horizontal section 1.5 m below the floor.

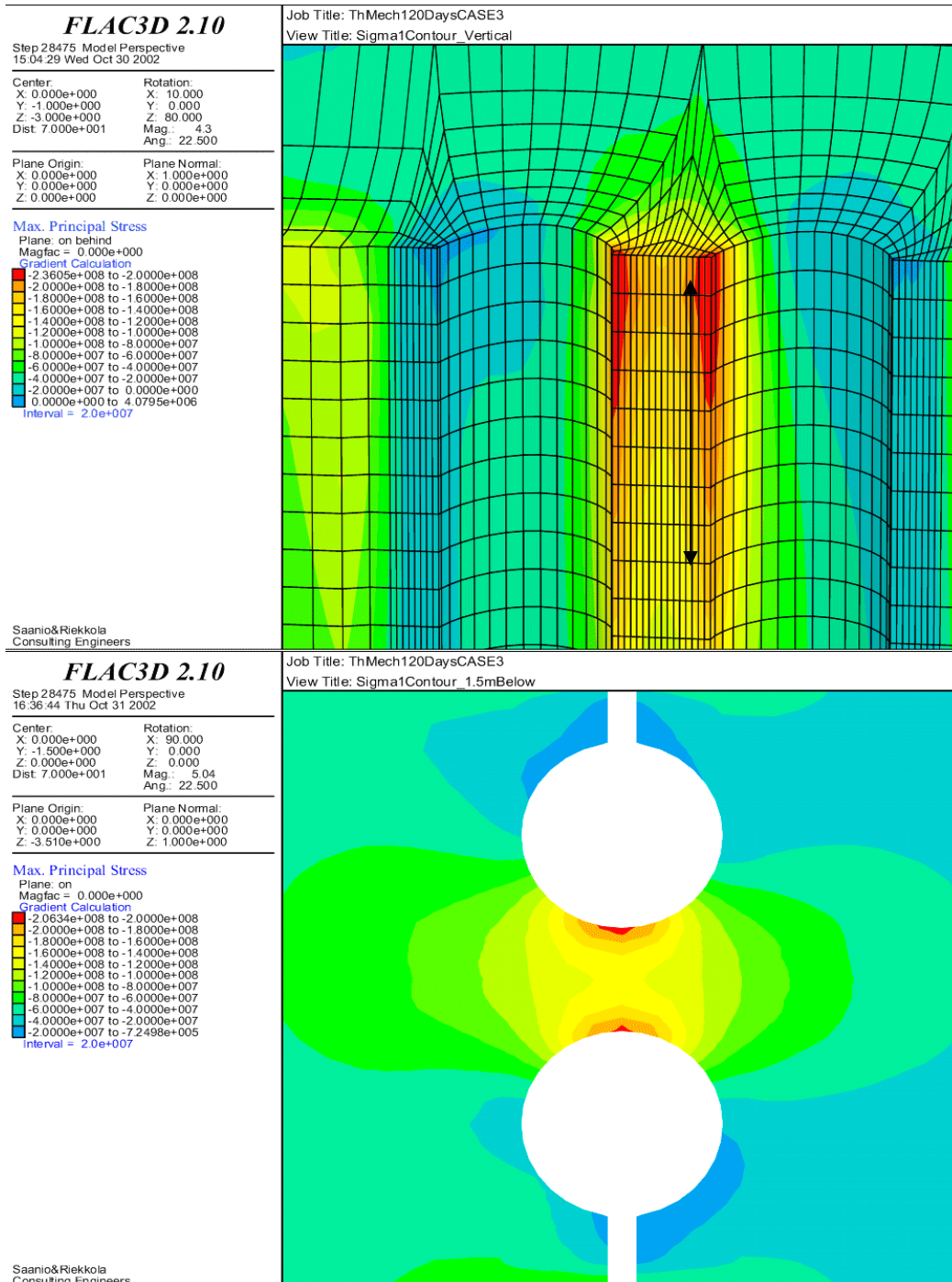


**Figure 3-7.** Model with slots and thermal load. Maximum principal stresses at the pillar area. At the first 3.5 meters (black arrow) of the pillar the stresses are over 160 MPa. Vertical line spacing at the pillar is about 0.5 m. Model with slots. Upper section is vertical and aligned along the tunnel axis. The lower section is horizontal at a depth of 1.5 m below the tunnel floor.



### 3.4 Stress state 3 (35, 15, 10 MPa) with slots

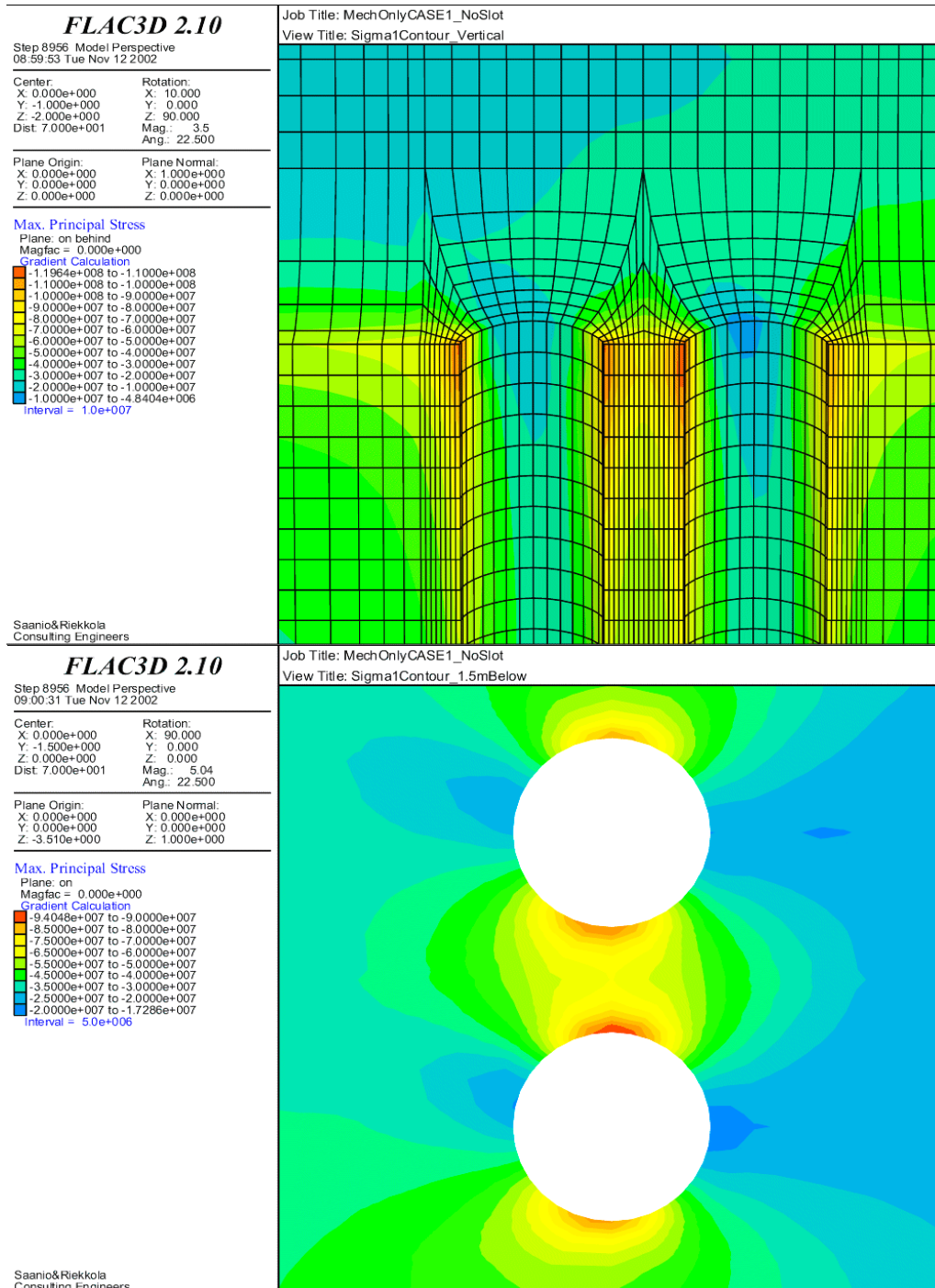
After 120 days of heating the stresses in mid-pillar at the level of 1.5 m below the floor are about 150 MPa. A maximum stress at the top of the pillar is about 240 MPa which is even higher than the peak strength of the rock. Figure 3-8 shows maximum stress contours on a vertical section of the model and at the horizontal section 1.5 m below the floor.



**Figure 3-8.** Model with slots and thermal load. Maximum principal stresses at the pillar area. At the first 3.5 meters (black arrow) of the pillar the stresses are over 180 MPa. Vertical line spacing at the pillar is about 0.5 m. Model with slots. Upper section is vertical and aligned along the tunnel axis. The lower section is horizontal at a depth of 1.5 m below the tunnel floor.

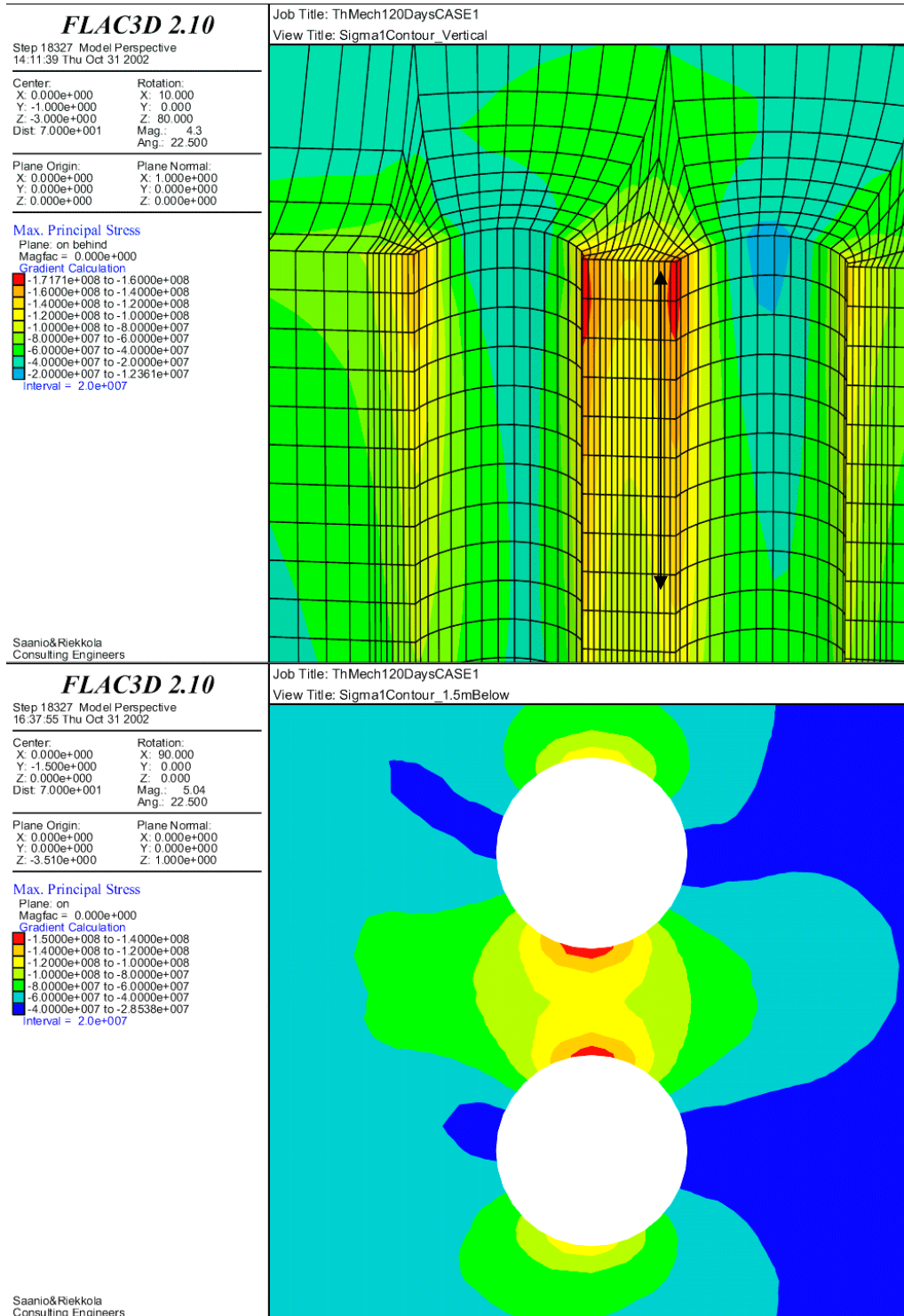
### 3.5 Stress state 1 (25, 15, 10 MPa) without slots

Stresses at the pillar area before heating is greatly affected by the complex excavation geometry and the induced stresses around the area of interest are shown in Figure 3-9. The maximum stresses in mid-pillar at the level of 1.5 m below the floor are about 65 MPa. Maximum stresses at the top of the pillar are about 120 MPa compared to 130 MPa with slots.



*Figure 3-9. Model without thermal load and no slots. Maximum principal stresses at the pillar area. Vertical line spacing at the pillar is about 0.5 m. Model without slots and no thermal load. Upper section is vertical and aligned along the tunnel axis. The lower section is horizontal at a depth of 1.5 m below the tunnel floor.*

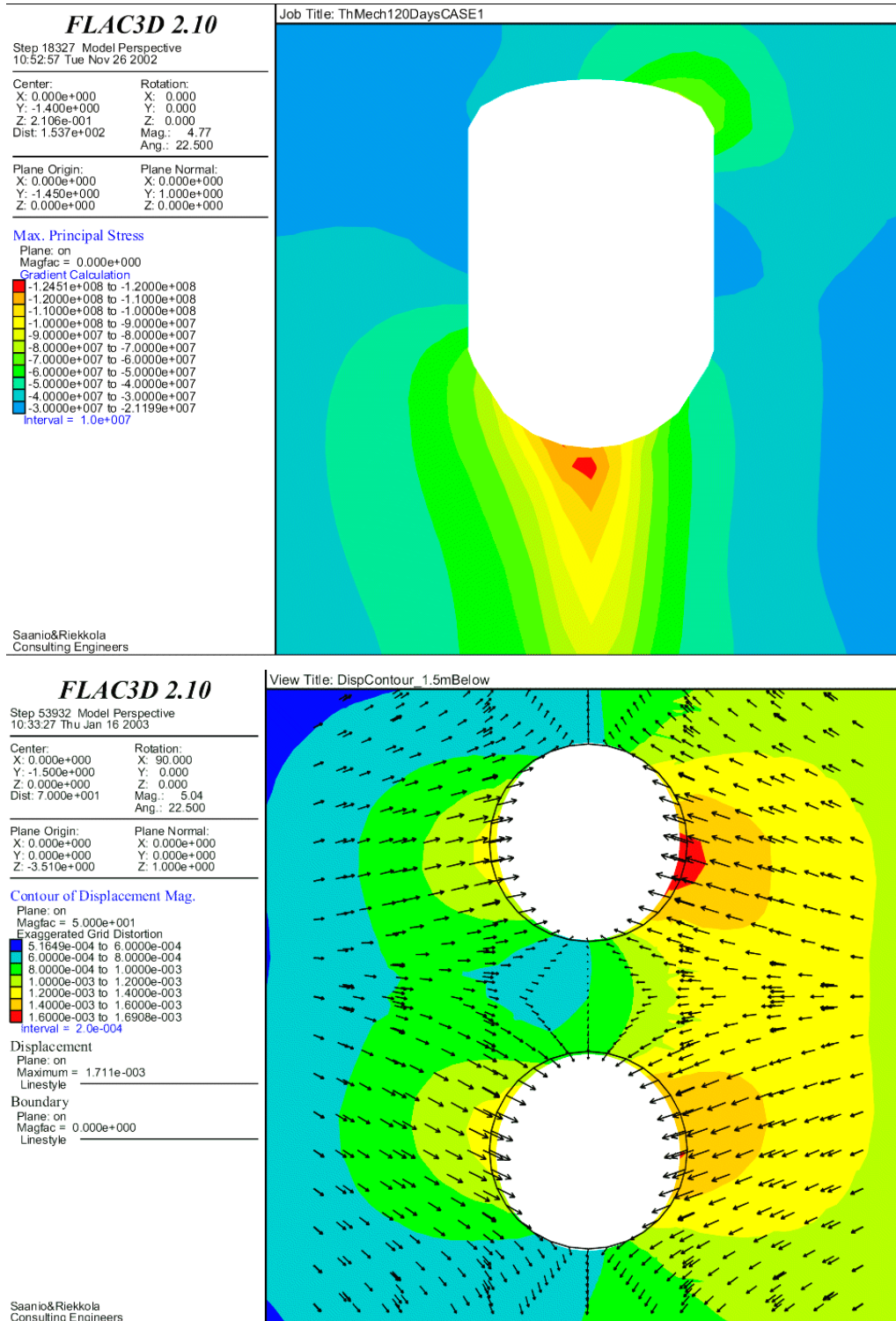
After 120 days of heating the stresses in mid-pillar at the level of 1.5 m below the floor are about 105 MPa. A maximum stress at the top of the pillar is about 170 MPa. Figure 3-10 shows maximum stress contours on a vertical section of the model near the holes and at the horizontal section 1.5 m below the floor.



**Figure 3-10.** Model with thermal load and no slots. Maximum principal stresses at the pillar area. At the first 4 meters (black arrow) of the pillar the stresses are over 120 MPa which is close to the crack initiation stress. Vertical line spacing at the pillar is about 0.5 m. Model without slots. Upper section is vertical and aligned along the tunnel axis. The lower section is horizontal at a depth of 1.5 m below the tunnel floor.



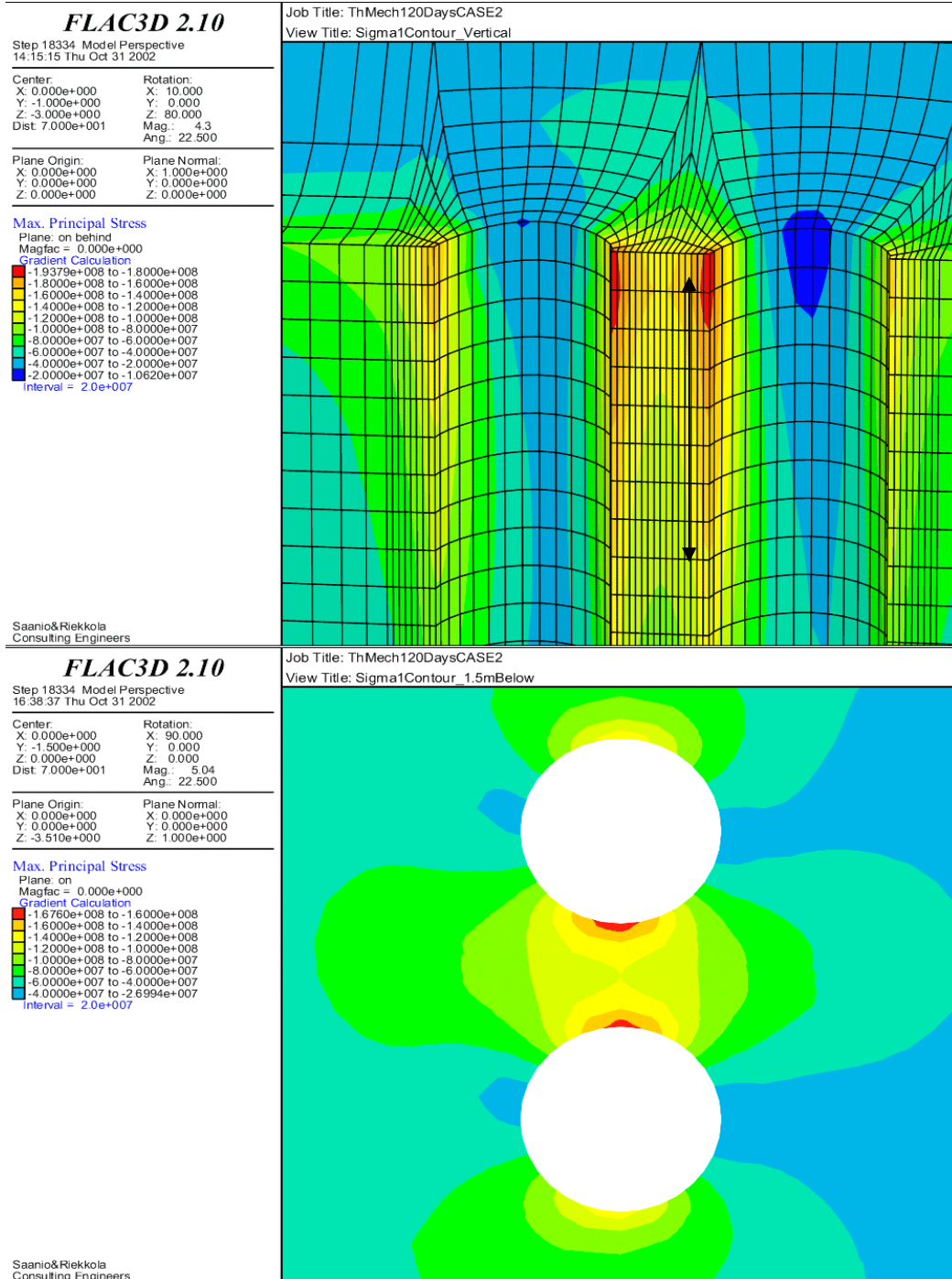
Vertical section perpendicular to the tunnel axis shows that the stresses are not symmetrically distributed around the excavation which is due to the inclined in-situ maximum principal stress. Maximum displacement at the level of 1.5 m below the tunnel floor is 1.7 mm towards the hole midpoint, see Figure 3-11.



**Figure 3-11.** Model with thermal load and no slots. Maximum principal stresses at the mid-pillar cross-section perpendicular to the tunnel axis (upper). Displacements (magnitudes and directions) at the section in horizontal plane at a depth of 1.5 m below the tunnel floor (lower). Situations after 120 days of heating.

### 3.6 Stress state 2 (30, 15, 10 MPa) without slots

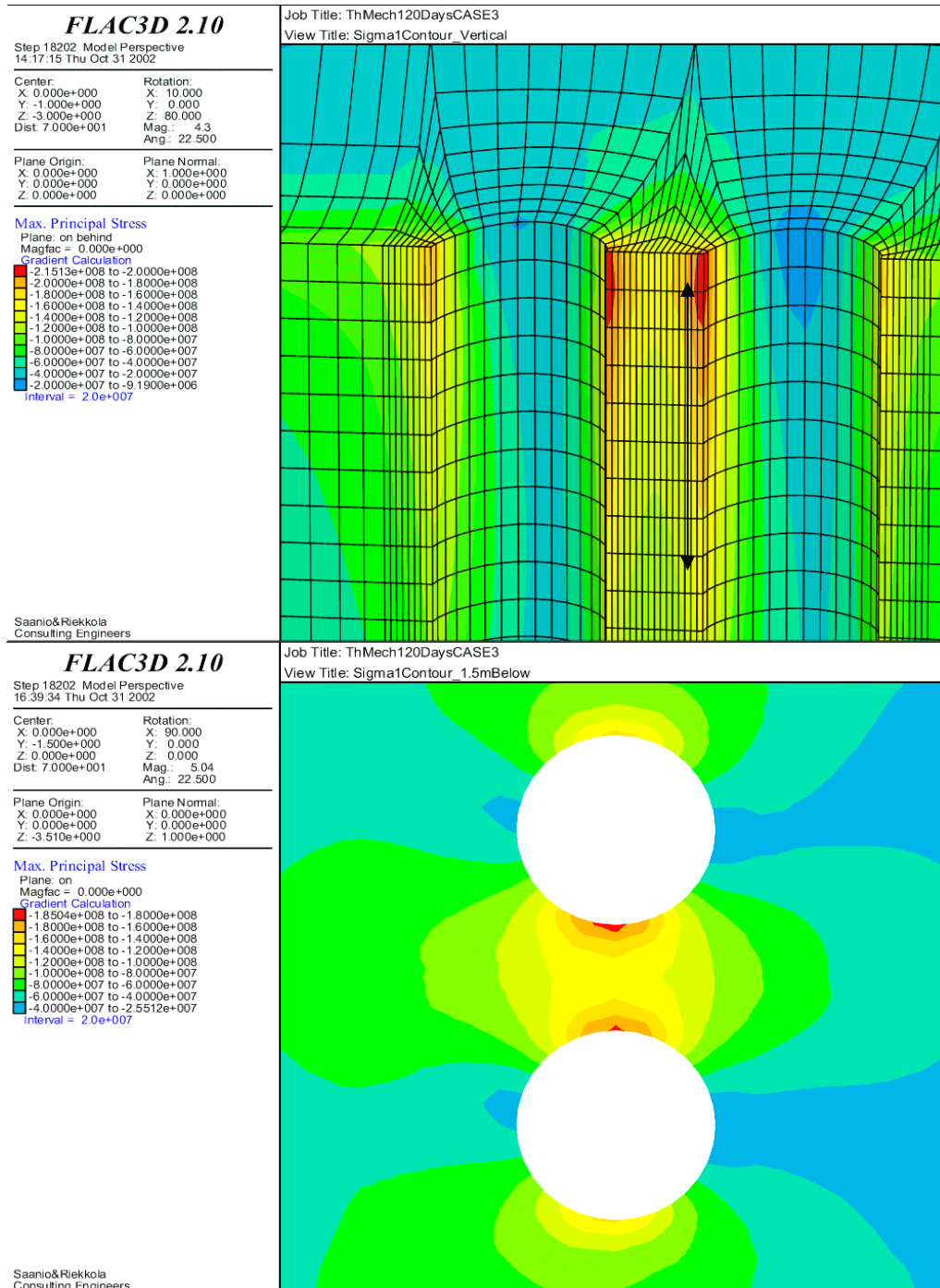
After 120 days of heating the stresses in mid-pillar at the level of 1.5 m below the floor are about 120 MPa which is close to the crack initiation stress. A maximum stress at the top of the pillar is about 190 MPa. Figure 3-12 shows maximum stress contours on a vertical section of the model near the holes and at the horizontal section 1.5 m below the floor.



**Figure 3-12.** Model with thermal load and no slots. Maximum principal stresses at the pillar. At the first 3.5 meters (black arrow) of the pillar the stresses are over 140 MPa. Vertical line spacing at the pillar is about 0.5 m. Model without slots. Upper section is vertical and aligned along the tunnel axis. The lower section is horizontal at a depth of 1.5 m below the tunnel floor.

### 3.7 Stress state 3 (35, 15, 10 MPa) without slots

After 120 days of heating the stresses in mid-pillar at the level of 1.5 m below the floor are about 135 MPa. A maximum stress at the top of the pillar is about 215 MPa which is higher than the crack damage stress. Figure 3-13 shows maximum stress contours on a vertical section of the model near the holes and at the horizontal section 1.5 m below the floor.



**Figure 3-13.** Model with thermal load and no slots. Maximum principal stresses at the pillar. At the first 3.5 meters (black arrow) of the pillar the stresses are over 160 MPa. Vertical line spacing at the pillar is about 0.5 m. Model without slots. Upper section is vertical and aligned along the tunnel axis. The lower section is horizontal at a depth of 1.5 m below the tunnel floor.

### 3.8 Sensitivity analyses

For the determination of the influence of the thermal properties and Young's modulus on the outcome of the modeling results few simulations were performed with alteration of the parameters. The in-situ stress state was 30, 15, 10 MPa, the model without slots, and other properties as previously. Each simulation was performed so that it produced results after 30, 60, 90, and 120 days of heating. The first cases were thermal only simulations and the second were with thermal-mechanical coupling. This totals 24 simulations save files and 2000Mb of saved information. Table 3-2 shows the analyzed cases.

**Table 3-2. Sensitivity analyses were performed with two parameters.**

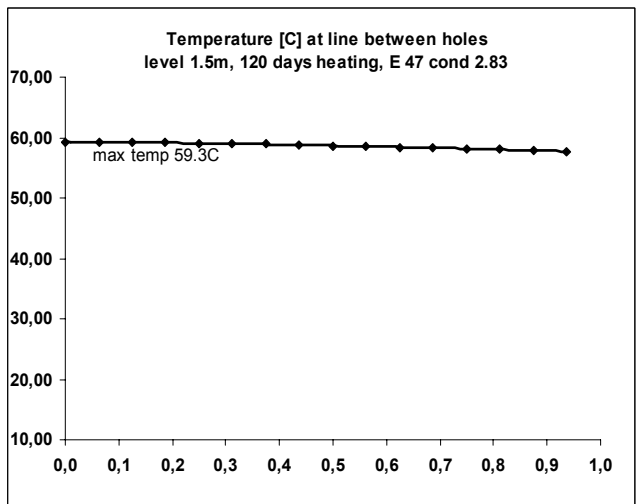
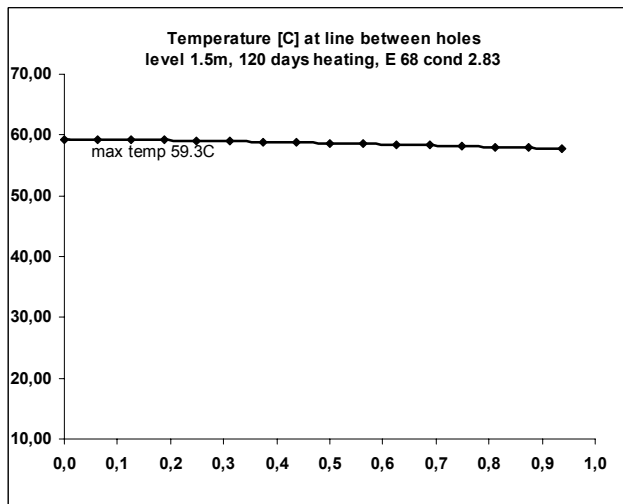
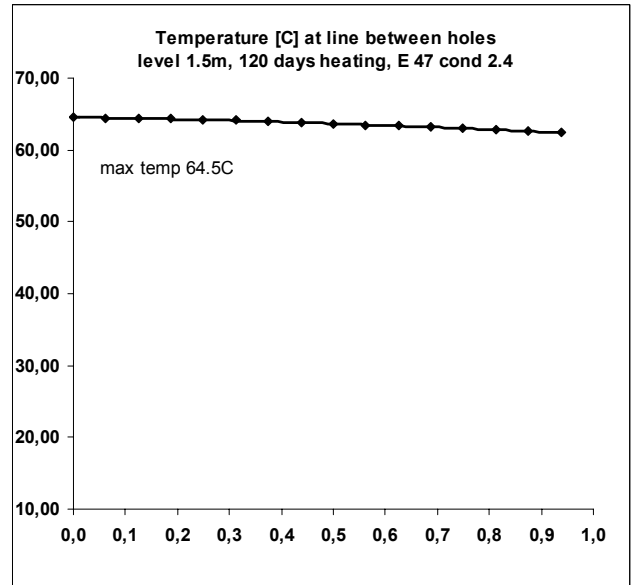
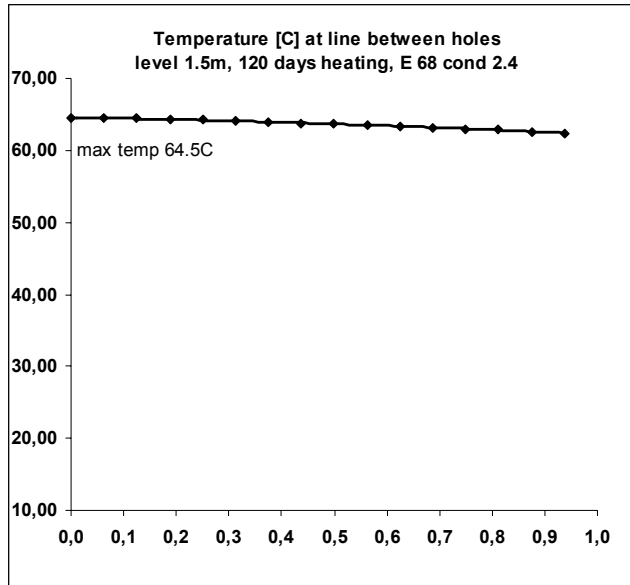
Analysis	Young's modulus [GPa]	Conductivity [W/m, K]	Modulus-Conductivity combinations
#1	68	2.83	High-High, [basic case]
#2	68	2.4	High-low
#3	47	2.83	Low-high
#4	47	2.4	Low-low

The results show that the parameters have an influence to the results. Table 3-3 summarizes the sensitivity results in a plane of 1.5 m below the tunnel floor. Figure 3-14 shows temperature profiles at the level of 1.5 m below the tunnel floor for each analyzed case after 120 days heating. Figure 3-15 shows stress profiles from same location. Figure 3-16 shows the stresses in the mid-pillar area during heating.

In Figure 3-15 there are four stress values in each point because in 3D environment in FLAC3D there is no stress value for any given one dimensional point in space. All the stress values are obtained from a volume. The line of interest (shortest between the holes) is located along an intersection of zones. Looking along the line the zones are located at up-left, up-right, down-left, and down-right. Along the line there are approx. 16 zones (times four). For a stress inquiry from any given point at the line it outputs four closest stress values which come from the adjacent zones. Those are plotted in Figure 3-15. The upper stress values are from zones above the level of interest and the lower values from under the level of interest. The fitted black line is thought to be the average stress obtained from the zones and represent the stress value at the level of interest (ex. at a level of 1.5 m).

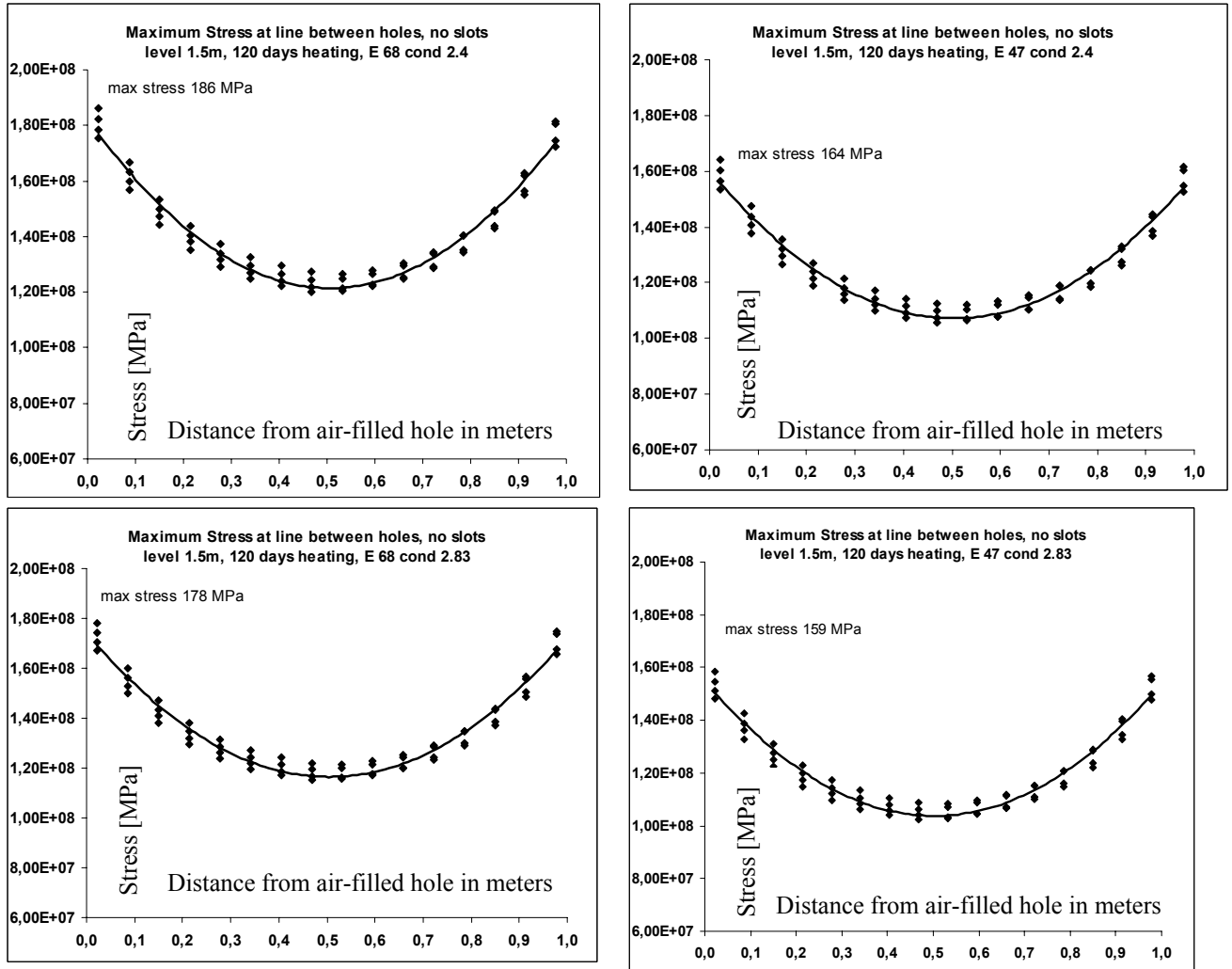
**Table 3-3. Maximum stresses at the level of 1.5 m below the tunnel floor for different modulus and thermal conductivity values after 120 days heating. Upper table shows values near the hole and the lower table values at the mid-pillar area.**

<b>Maximum stresses at the level of 1.5 m below the tunnel floor, near hole walls</b>		
<i>Young's modulus [GPa]</i>	<i>Conductivity [W/m, K]</i>	
	2.4	2.83
47	<b>164 MPa</b>	<b>159 MPa</b>
68	<b>186 MPa</b>	<b>178 MPa</b>
<b>Maximum stresses at the level of 1.5 m below the tunnel floor, mid-pillar area</b>		
47	<b>106 MPa</b>	<b>102 MPa</b>
68	<b>120 MPa</b>	<b>115 MPa</b>

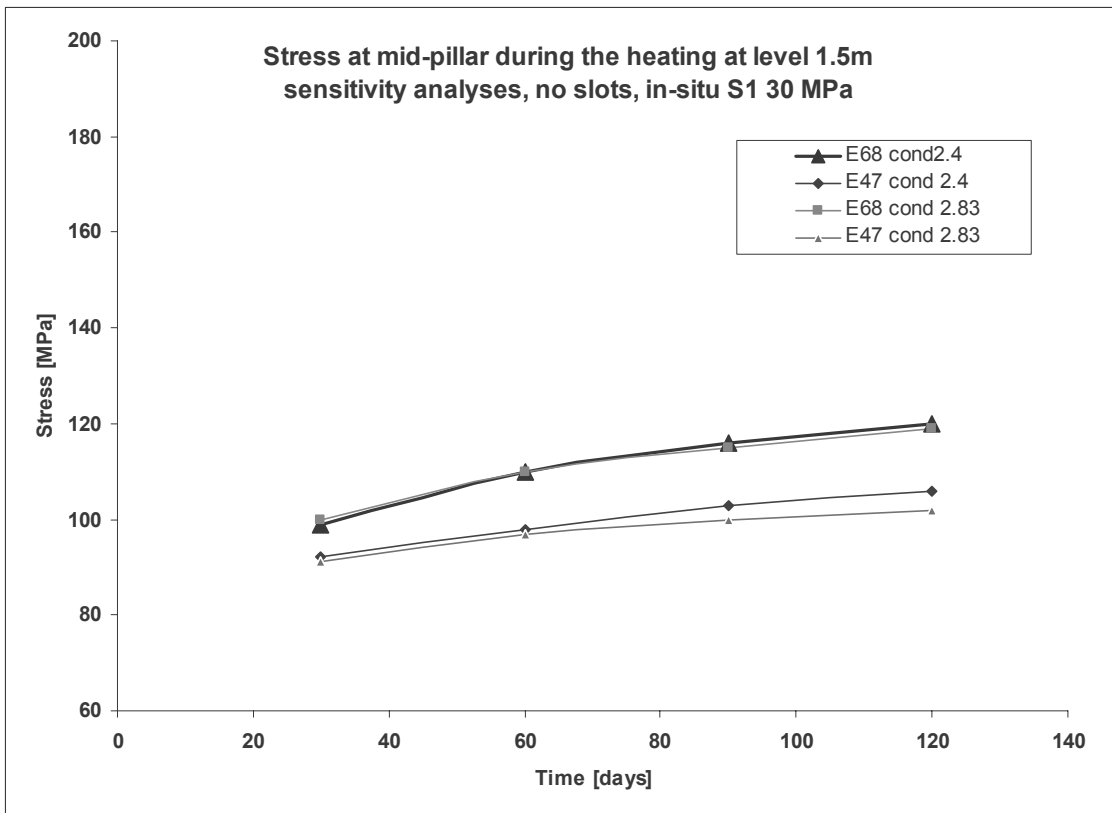
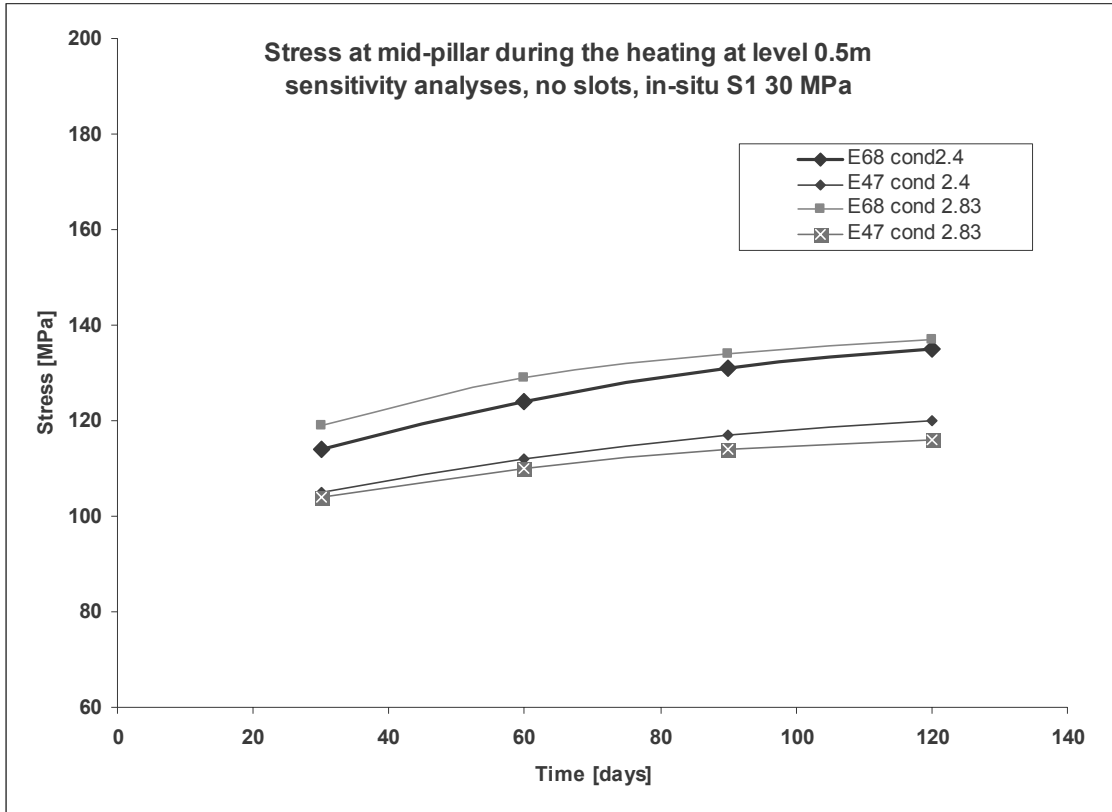


**Figure 3-14.** Temperature profiles for sensitivity analyses. Profiles at the level of 1.5 m below the tunnel floor after 120 days heating. Up-left: E 68 cond. 2.4, up-right: E 47 cond. 2.4, bottom-left: E 68 cond. 2.83, bottom-right: E 47 cond. 2.83. Horizontal axis from air-filled to water-filled hole in meters. Refer figures 3-1 and 3-3 for further explanation of the axes scale.





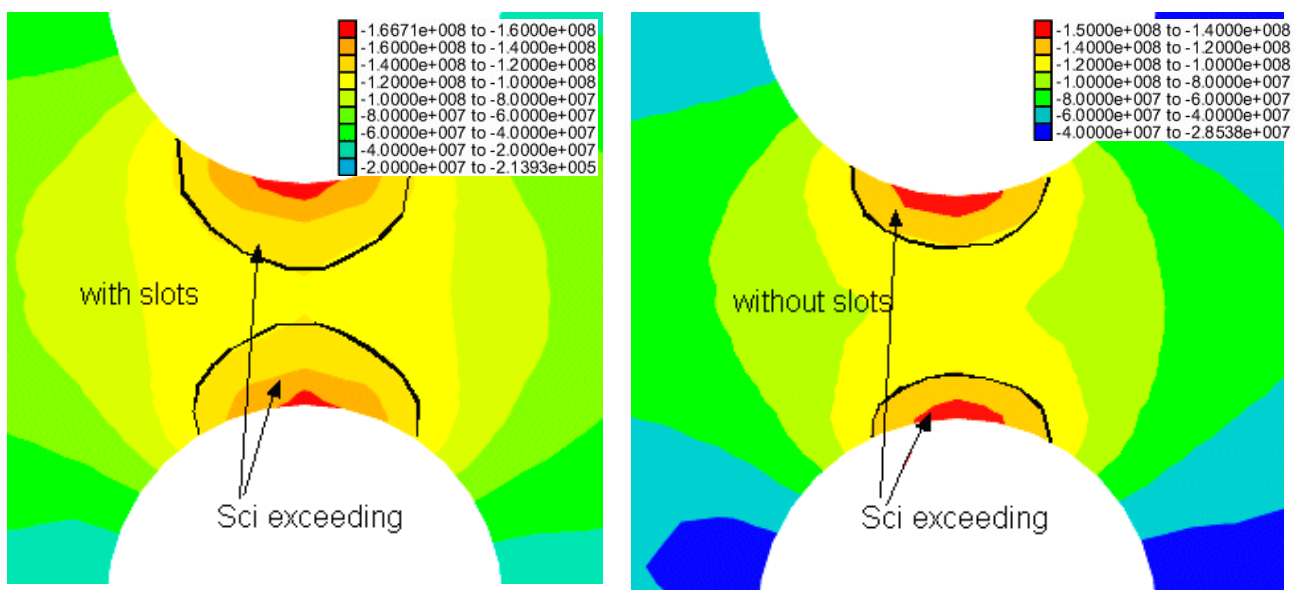
**Figure 3-15.** Stress profiles for sensitivity analyses. Profiles at the level of 1.5 m below the tunnel floor after 120 days heating. Up-left: E 68 cond. 2.4, up-right: E 47 cond. 2.4, bottom-left: E 68 cond. 2.83, bottom-right: E 47 cond. 2.83. Horizontal axis from air-filled to water-filled hole in meters. Refer figures 3-1 and 3-3 for further explanation of the axes scale.



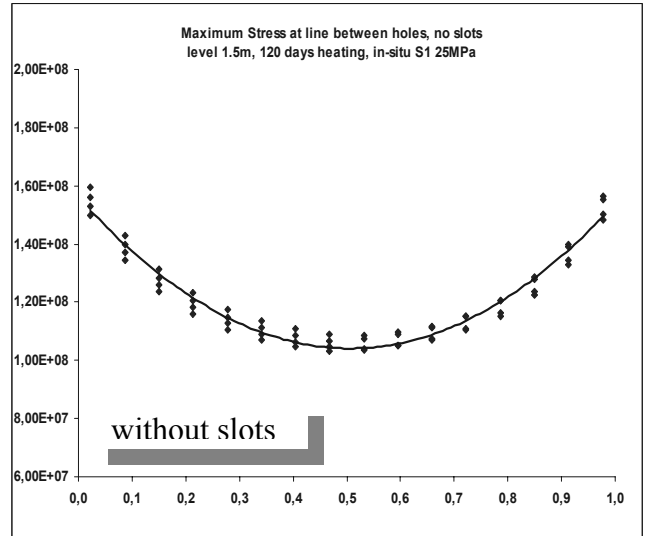
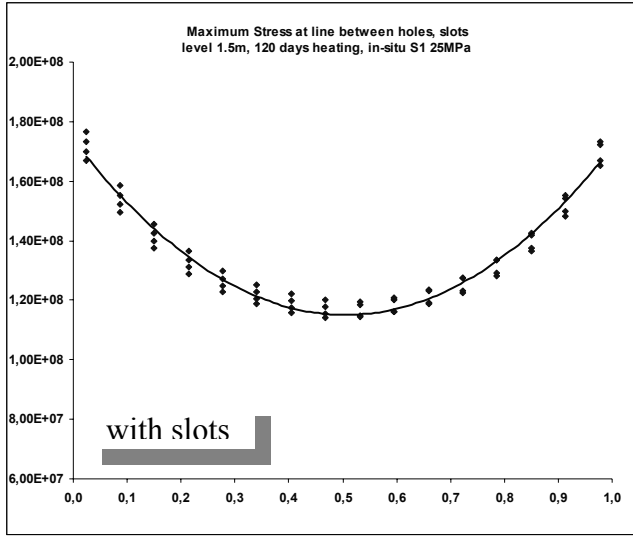
**Figure 3-16.** Stresses during the 120 days heating at the levels of 0.5 m (upper) and 1.5 m (below) the tunnel floor for model without slots for different thermal properties. In-situ stress state 30, 15, 10 MPa.

## 4 Comparison Slot - No slot

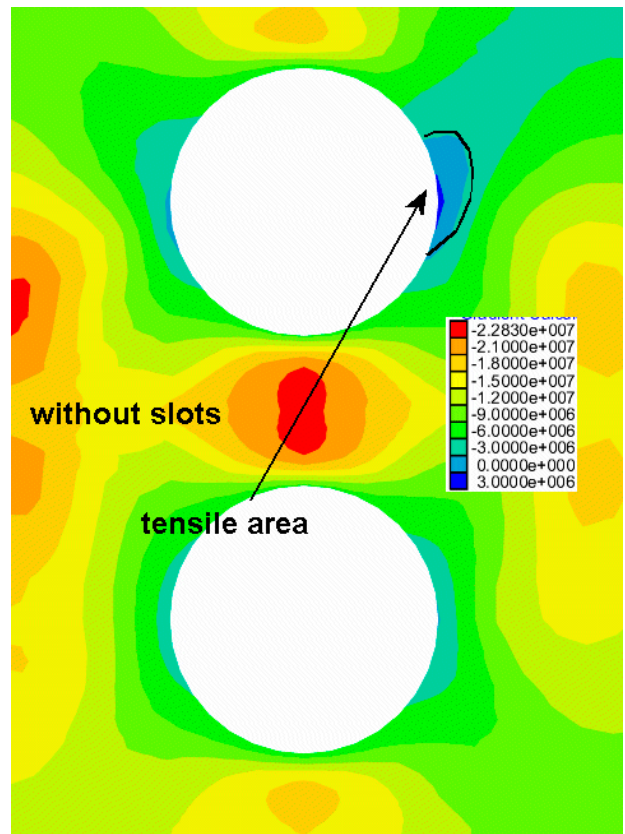
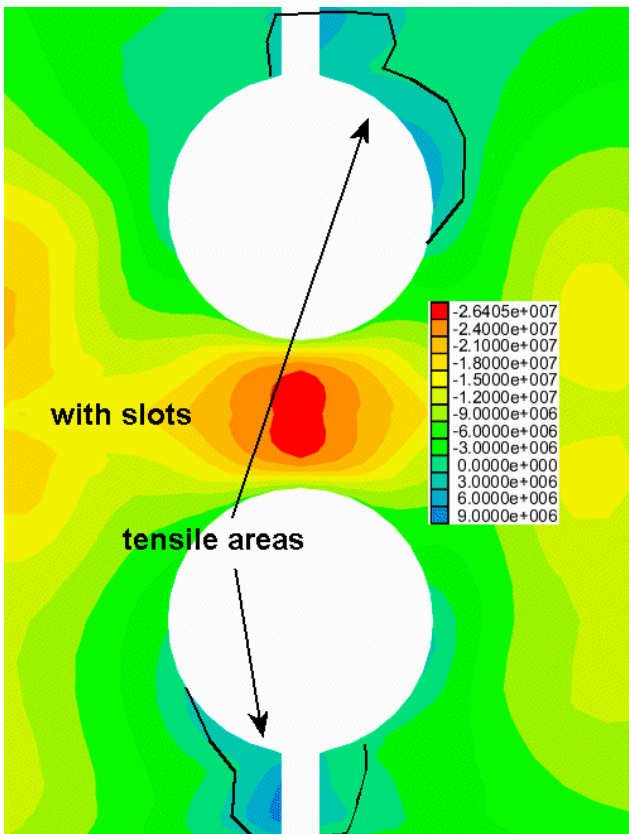
Comparison was made between the models with and without slots. The increase of the maximum principal stresses induced by the slots is about 10 MPa in mid-pillar area and about 20 MPa near the holes. The slots increase also the tensile stress areas as well as the tensile stress values. In both cases the stresses at the hole wall exceed the crack initiation strength but not the crack damage strength. Figures 4-1 to 4-3 compare the stresses at the level of 1.5 m below the tunnel floor for the in-situ stress state of 25, 15, 10 MPa.



**Figure 4-1.** Comparison of the maximum principal stress contours at the horizontal section at a level of 1.5 m below the tunnel floor after 120 days heating. Left the model with slots and right the model without slots. In-situ stress state 25, 15, 10 MPa.



**Figure 4-2.** Comparison of the maximum principal stress profiles at the level of 1.5 m below the tunnel floor after 120 days heating. Left the model with slots and right the model without slots. In-situ stress state 25, 15, 10 MPa.



**Figure 4-3.** Comparison of minimum principal stress contours at the horizontal section at a level of 1.5 m below the tunnel floor after 120 days heating. Left the model with slots and right the model without slots. In-situ stress state 25, 15, 10 MPa. Tensile stress areas are marked with arrows.

## 5 Summary

The complex geometry of the experiment area causes high stresses. When the maximum in-situ stress is 25 MPa the induced maximum principal stress at the top of the pillar is over 130 MPa in the geometry with slots and no thermal loading. The stress increase effect of the slots is about 10-20 MPa (~10%) depending on the location.

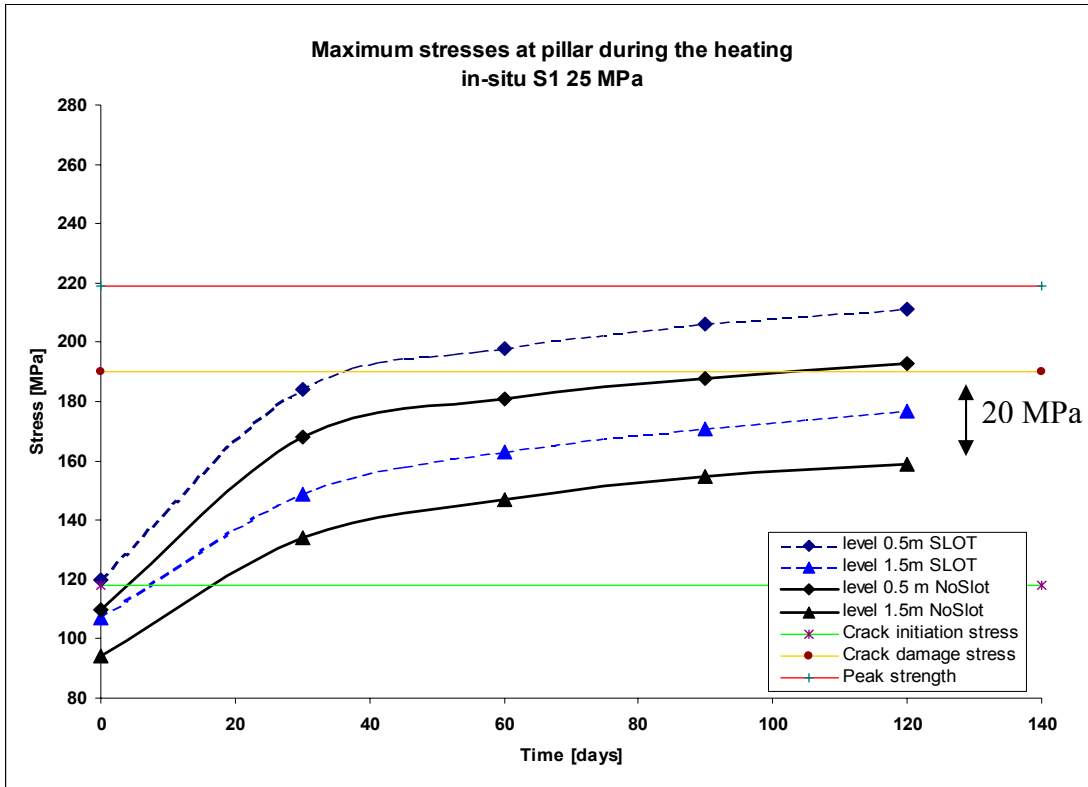
The initial temperature of 15°C rises about 50 degrees in the pillar area during the heating period of 120 days. The rising temperature induces stresses in the pillar area and after 120 days heating the stresses have increased about 40%. Figures 5-1 to 5-3 show the increase in stress at the two levels during the 120 days heating for model with and without slots and for each in-situ stress state. In the first case (Fig. 5-1) also the pre-heating stresses are presented.

The crack initiation stress ( $\sigma_{ci} \sim 118$  MPa) is exceeded even before the heating at the upper part of the pillar in each modeling case. Crack damage stress ( $\sigma_{cd} \sim 190$  MPa) and peak strength ( $\sigma_p \sim 219$  MPa) are exceeded in the hole wall after 120 days heating in every in-situ stress state case with slots. However in the model without slots the  $\sigma_{cd}$  and  $\sigma_p$  stresses are exceeded only with higher in-situ stress states ( $S1 = 30$  and  $35$  MPa). In some cases the slots have some meaningful effects, for example the crack damage stress is exceeded after 90 days heating when the maximum in-situ stress is 25 or 30 MPa with slots but not without slots. It should be noted that the strength values presented here correspond to an uniaxial stress state and in a triaxial situation the strength values are higher e.g. the peak strength of Äspö diorite is about 346 MPa with confinement of 20 MPa (Nordlund 1999). Since the presented rock strength properties are based on samples taken from overall Äspö area it is recommended that the rock strength values will be verified with laboratory tests on samples taken from the actual in-situ test site.

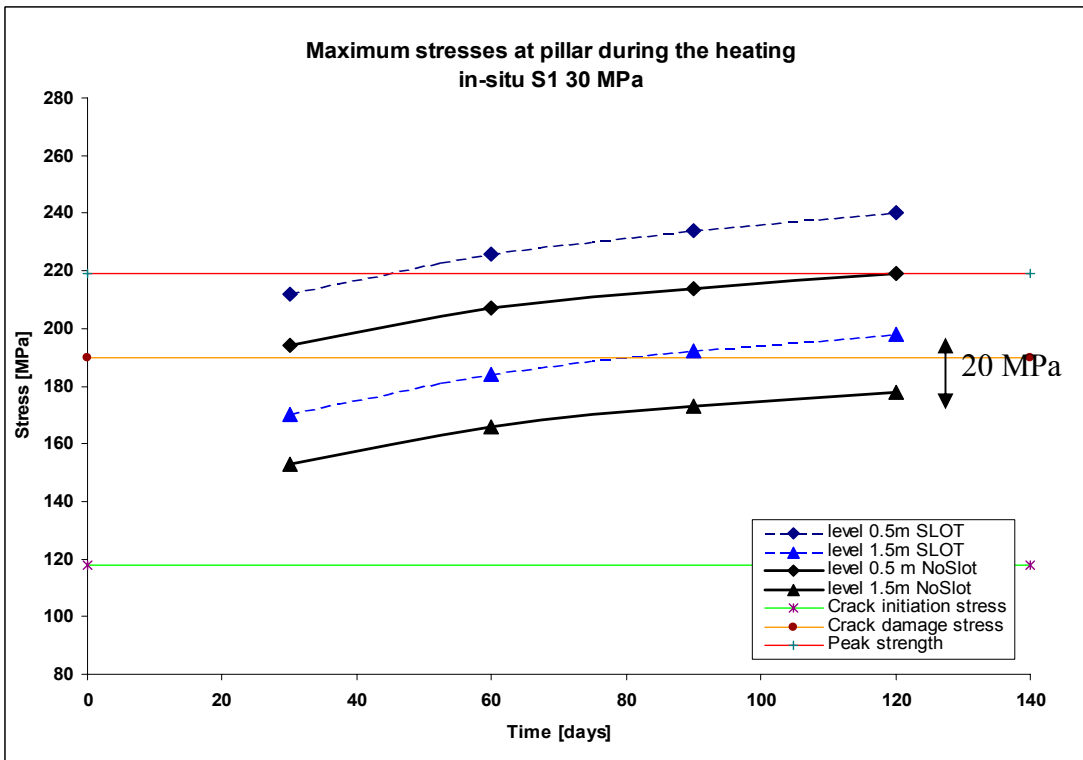
The tensile stress areas are located at hole walls. The areas exist even before the heating starts and are growing when the heat is on. Tensile stresses in addition to high compressive stresses might also induce some AE activity from the very beginning of the test and are thus potential areas where AE activities will be detected.

The sensitivity analyses showed that the modeled stresses are to some extent dependent on the used parameter values. As the conductivity increased by 15% the stresses decreased by 4%. And when the modulus value was increased by 45% the stresses increased 13%. This holds only for thermal calculation. When the thermal effect is neglected the modulus change does not affect the stresses. In order to verify the actual induced stresses on location the parameter values of thermal conductivity and Young's modulus at the test site should be checked by laboratory tests.

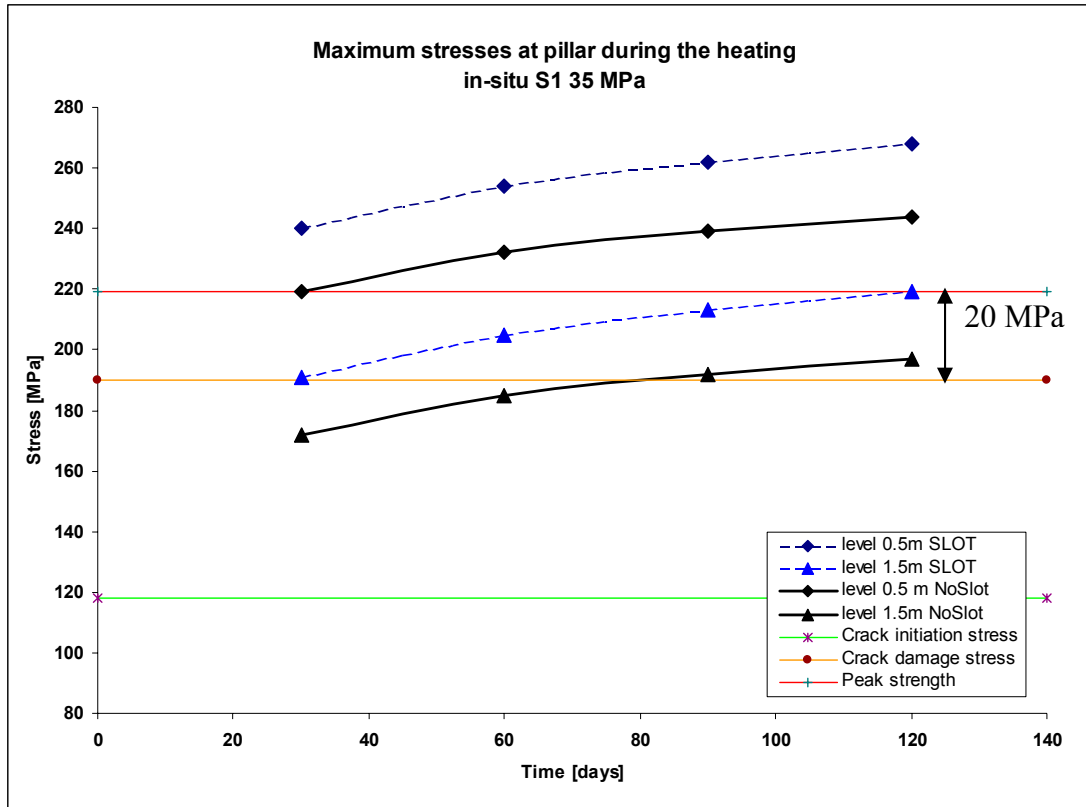
Based on the stress measurements in Äspö site the average major in-situ stress is  $27 \pm 2$  MPa so the analyzed cases with 35 MPa major stress is not regarded as realistic. The modeled cases with 25 and 30 MPa major in-situ stresses are considered to bound the right solution. However the in-situ stress state needs to be measured and confirmed at the exact test location.



**Figure 5-1.** Stress at the hole wall during the 120 days heating at the levels of 0.5 m and 1.5 m below the tunnel floor for model with [dashed line] and without slots [solid line]. In-situ stress state 25, 15, 10 MPa.



**Figure 5-2.** Stress at the hole wall during the 120 days heating at the levels of 0.5 m and 1.5 m below the tunnel floor for model with [dashed line] and without slots [solid line]. In-situ stress state 30, 15, 10 MPa.



**Figure 5-3.** Stress at the hole wall during the 120 days heating at the levels of 0.5 m and 1.5 m below the tunnel floor for model with [dashed line] and without slots [solid line]. In-situ stress state 35, 15, 10 MPa.





## 6 References

**Andersson C. 2003.** Äspö Pillar Stability Experiment. Feasibility study. IPR-03-01. SKB. Stockholm, Sweden.

**Fredriksson A., T. Janson & I. Staub. 2003.** Äspö Pillar Stability Experiment. Design of heaters and preliminary results from coupled 2D thermo-mechanical modelling. IPR-03-03. SKB. Stockholm, Sweden.

**Itasca consulting group, Inc. 2002.** FLAC3D (Fast Lagrangian Analysis of Continua in 3 Dimensions). Version 2.1. Minneapolis, USA.

**Staub, I., T.Janson & A. Fredriksson. 2003.** Äspö Pillar Stability Experiment. Geology and properties of the rock mass around the experiment volume. IPR-03-02. SKB. Stockholm, Sweden.

**Nordlund E., C. Li & B. Carlsson. 1999.** Mechanical properties of the diorite in the prototype repository at Äspö HRL. Laboratory tests. International progress report. IPR-99-25. SKB. Stockholm, Sweden.



## **7 List of appendices**

A: Temperature profile plots from APSE thermal-mechanical simulation, pages 30-34

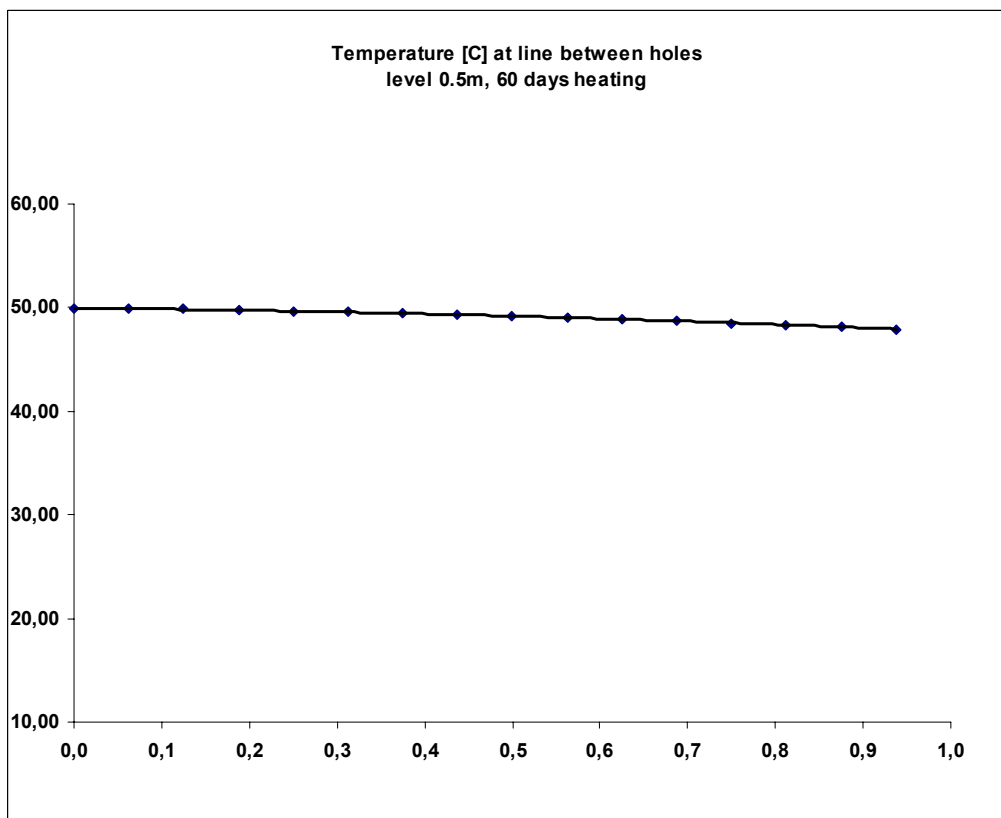
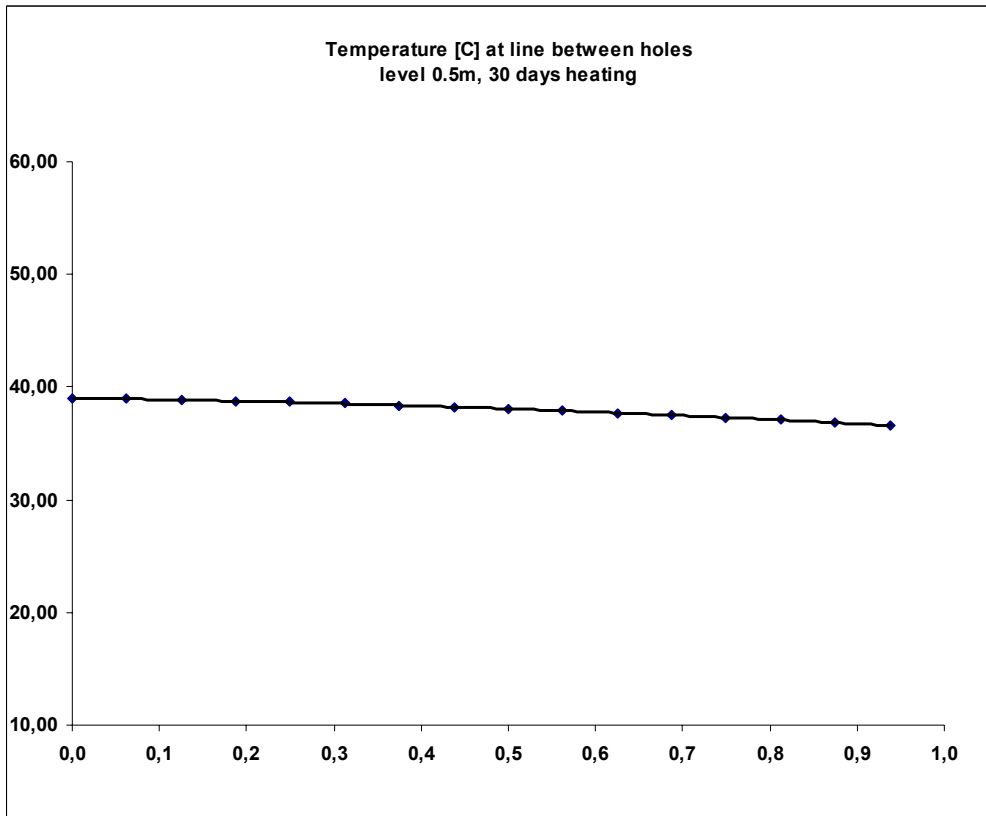
B: Stress profile plots from APSE thermal-mechanical simulation, pages 35-47

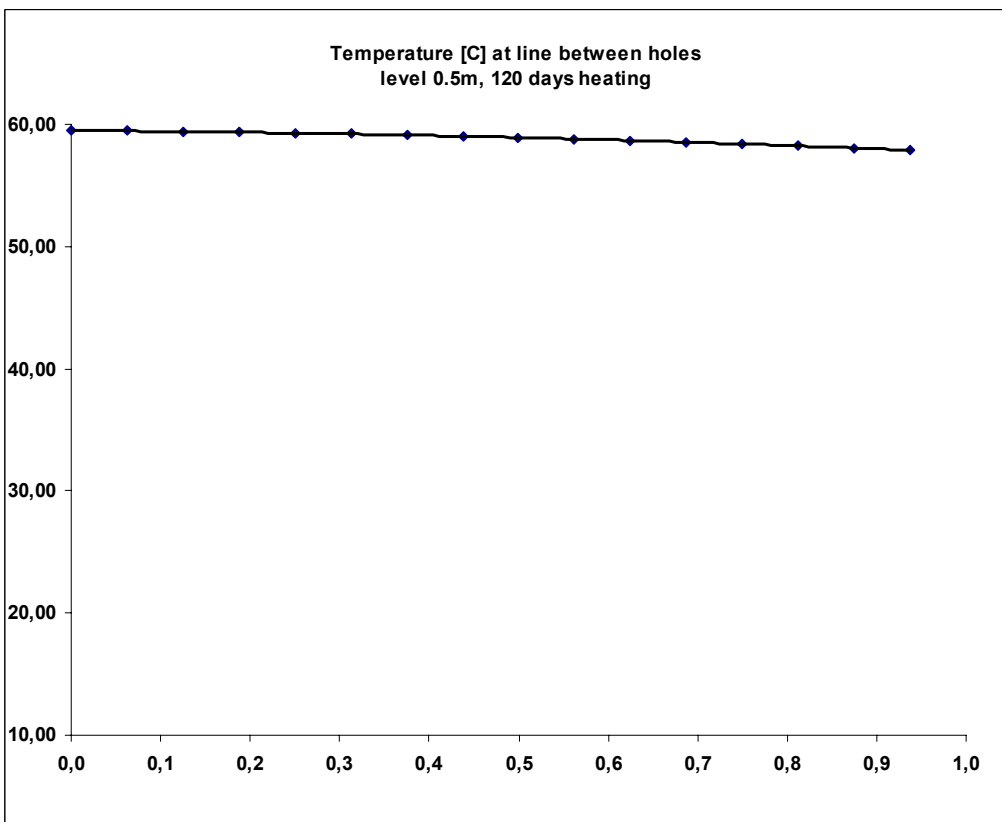
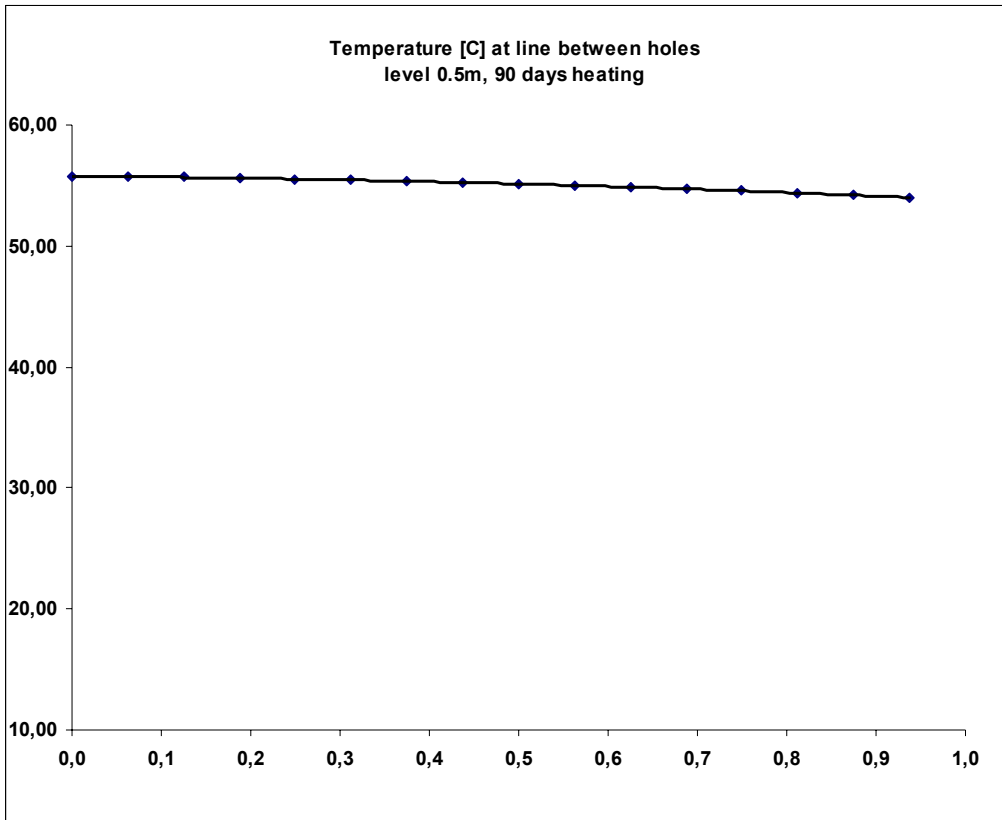


## **8 Appendix A: temperature profile plots from APSE thermal-mechanical simulation.**

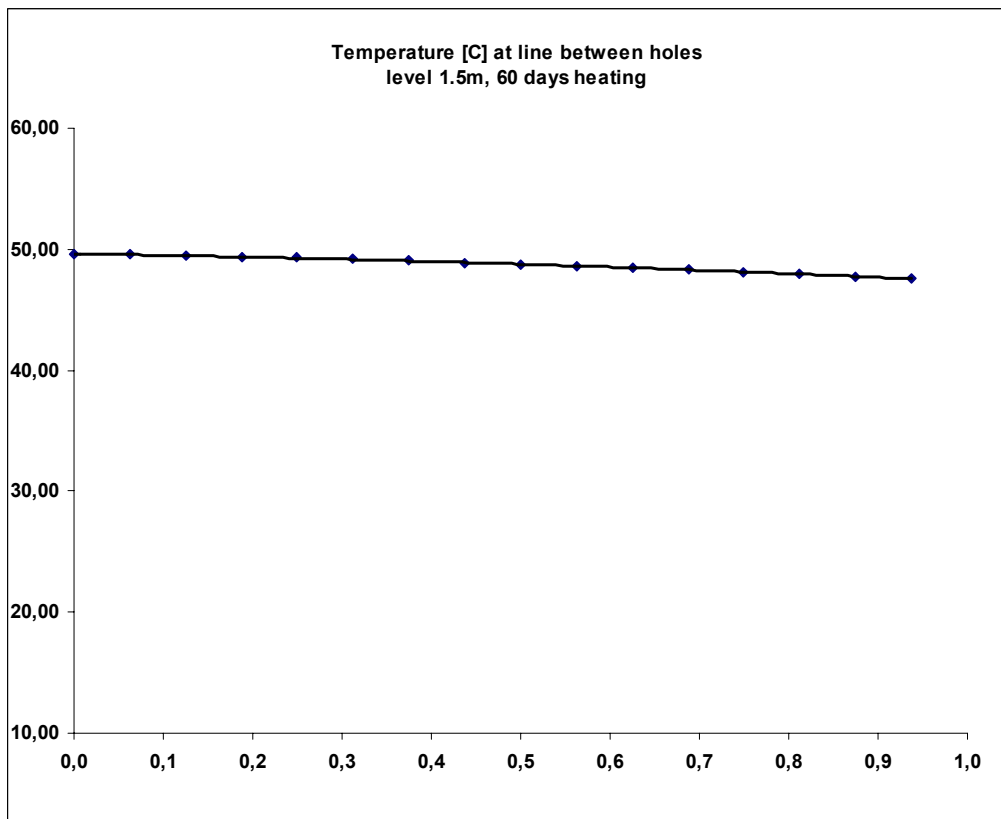
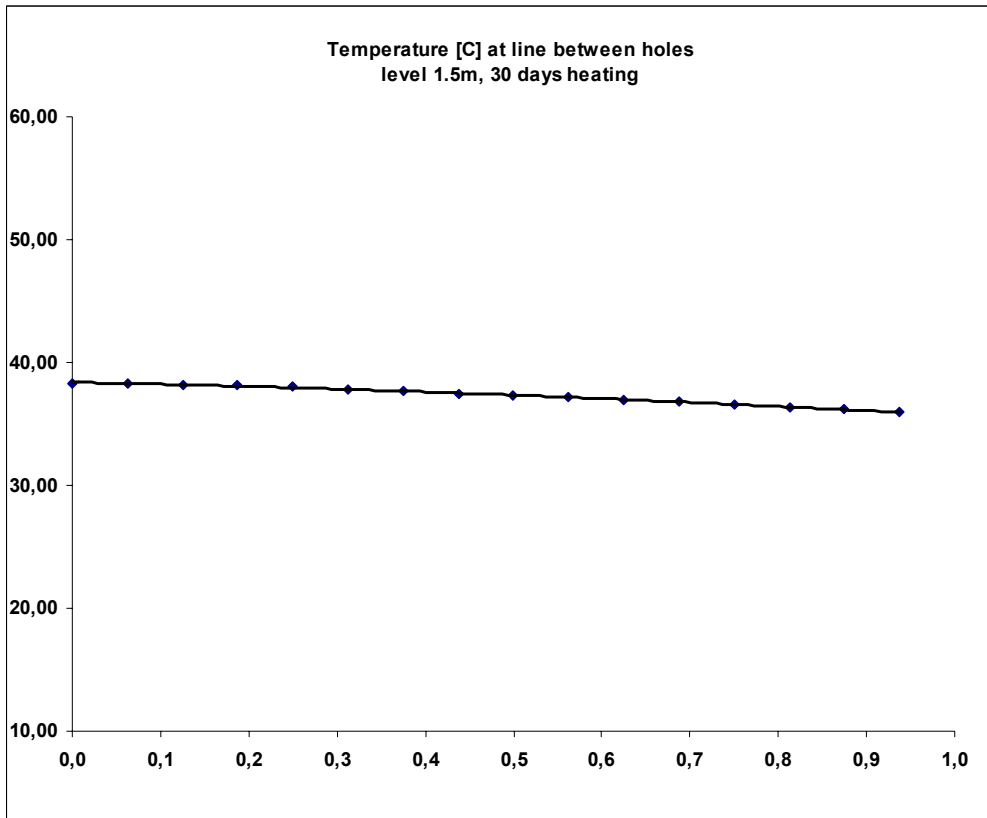
The horizontal axis scale is from air-filled hole (left) to water-filled hole (right) in meters. The plots are presented after 30, 60, 90, and 120 days of heating.

## 8.1 Temperature profiles at level 0.5m below the tunnel floor

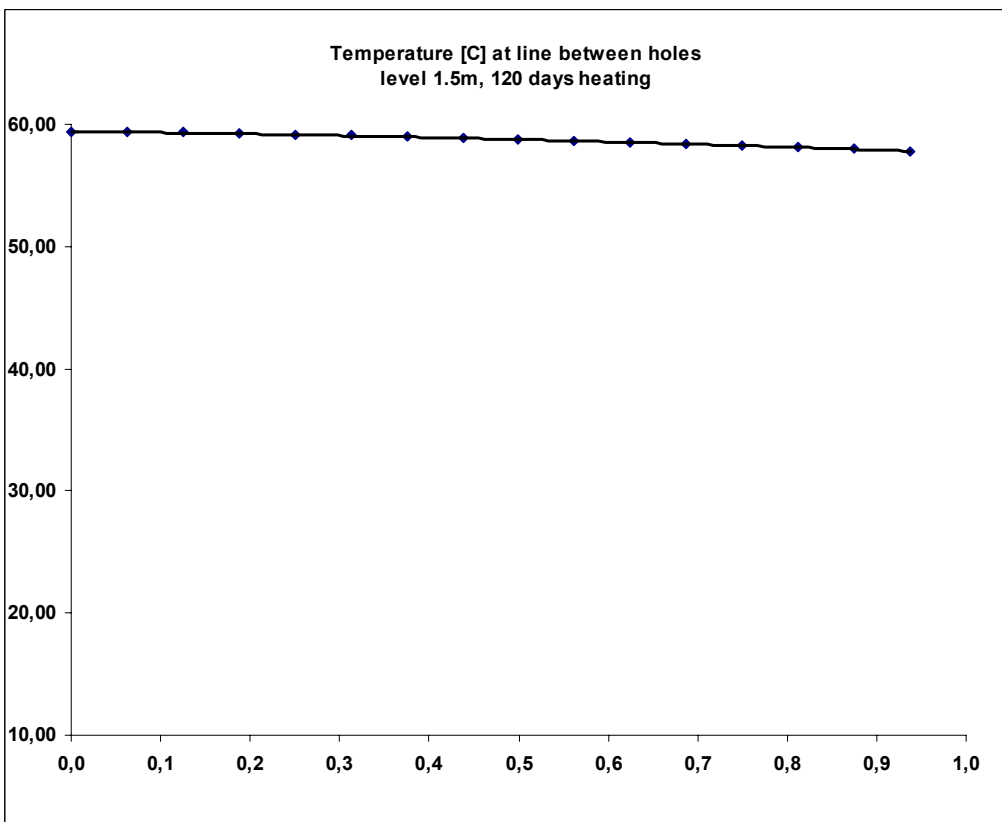
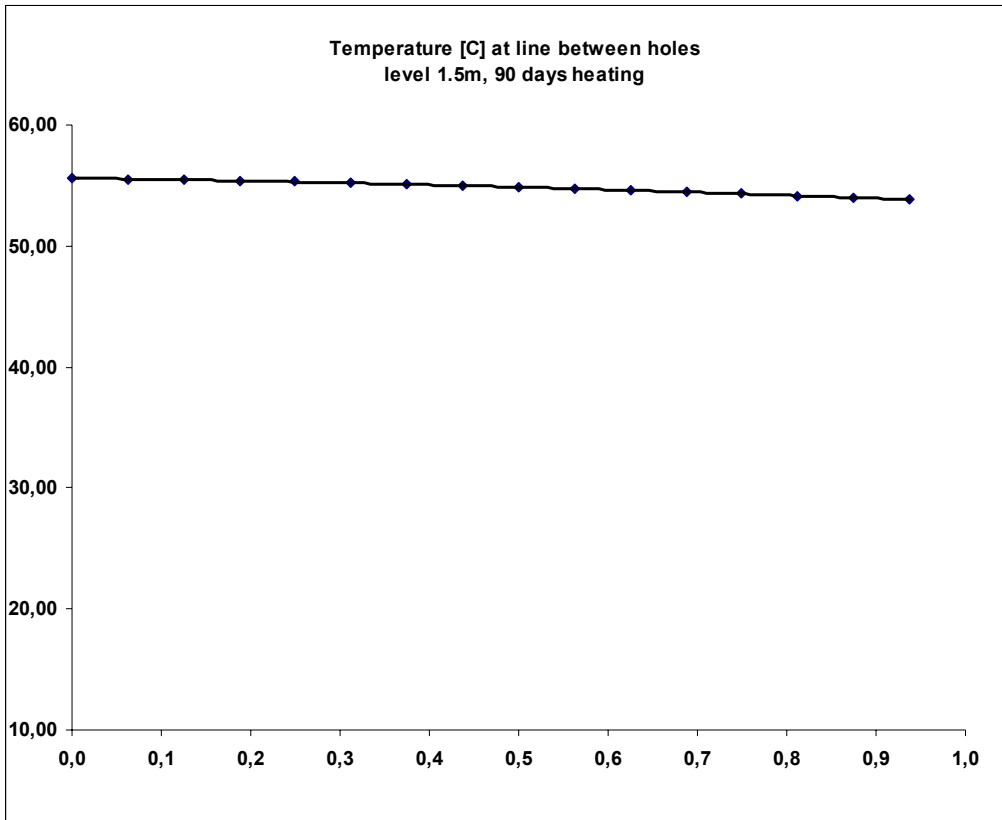




## 8.2 Temperature profiles at level 1.5m below the tunnel floor









## **9 Appendix B: Stress profile plots from APSE thermal-mechanical simulation.**

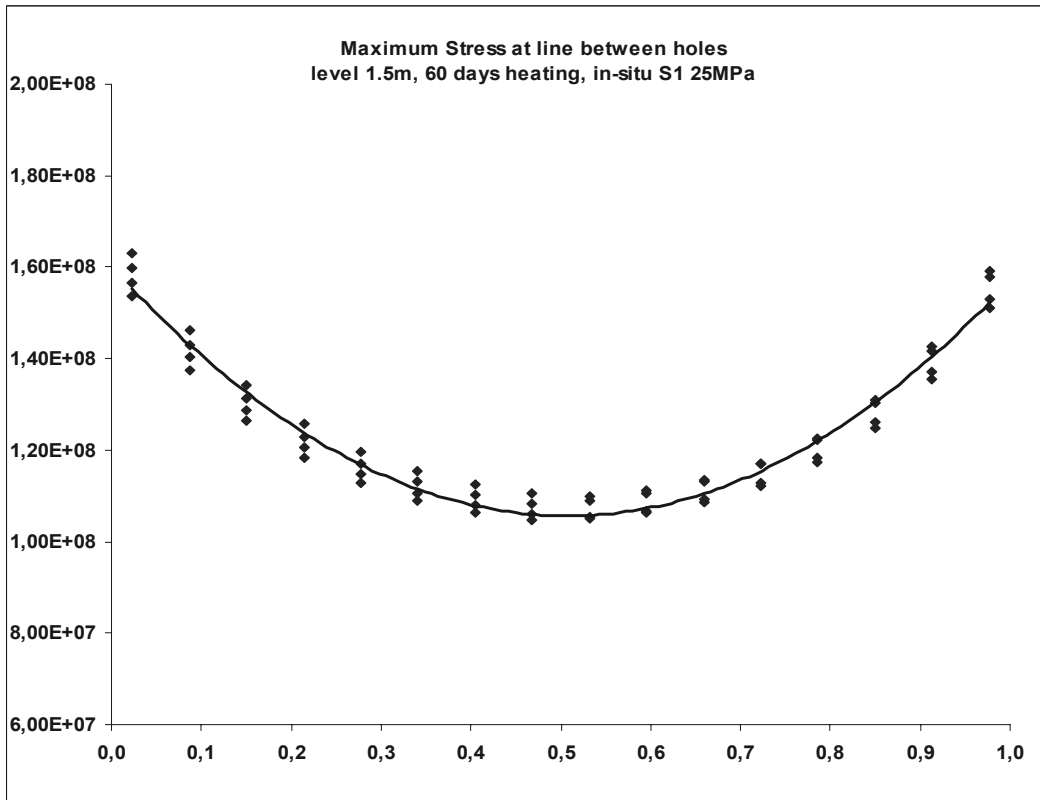
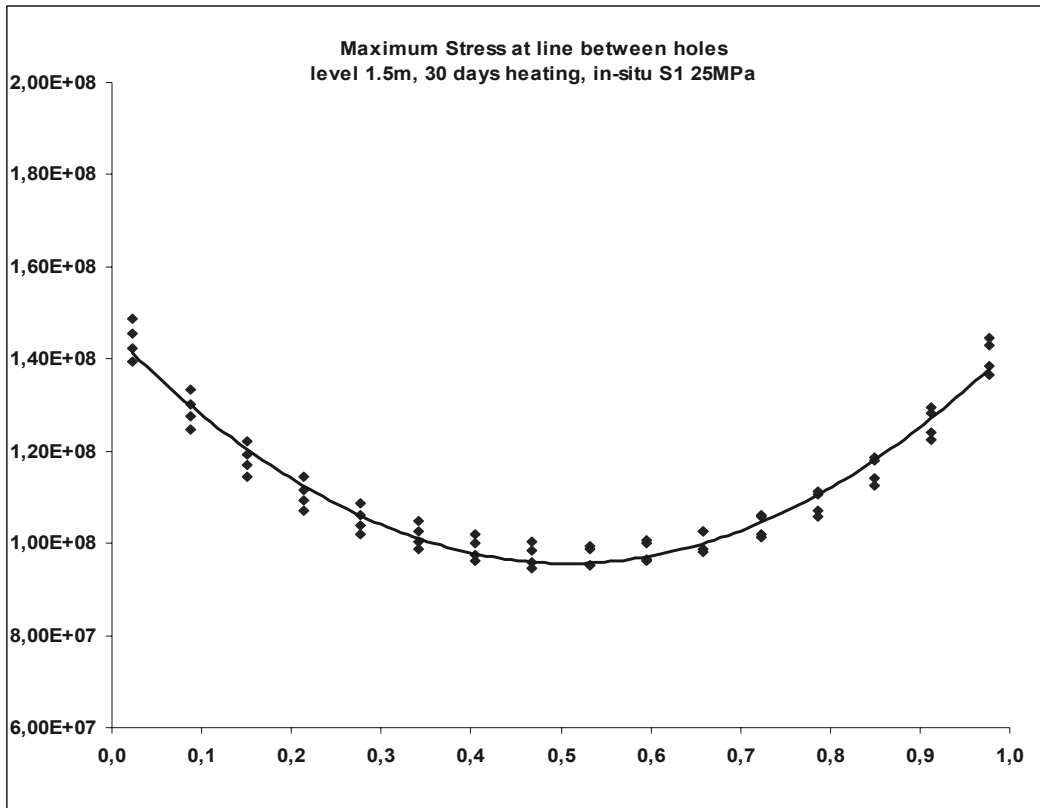
Plots represent maximum principal stresses at the line between the holes at the level of 1.5 meters below the tunnel floor. The horizontal axis scale is from air-filled hole (left) to water-filled hole (right) in meters. The plots are presented after 30, 60, 90, and 120 days of heating for three different in-situ stress state.

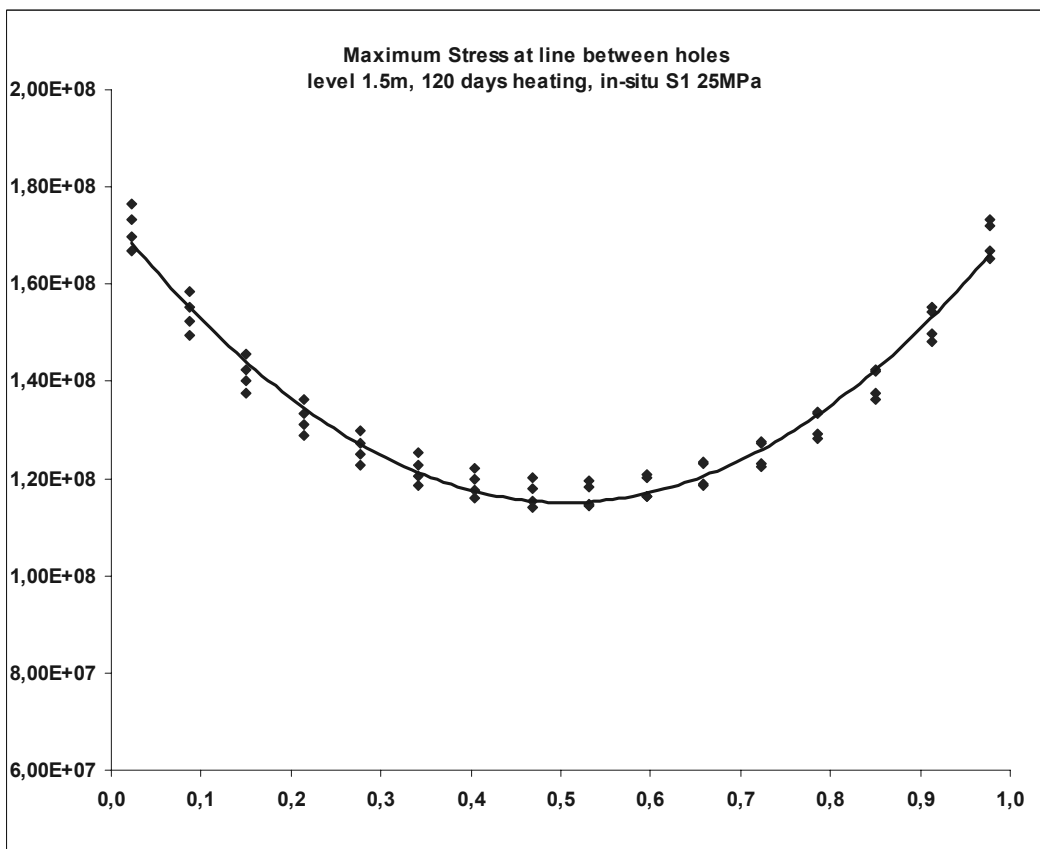
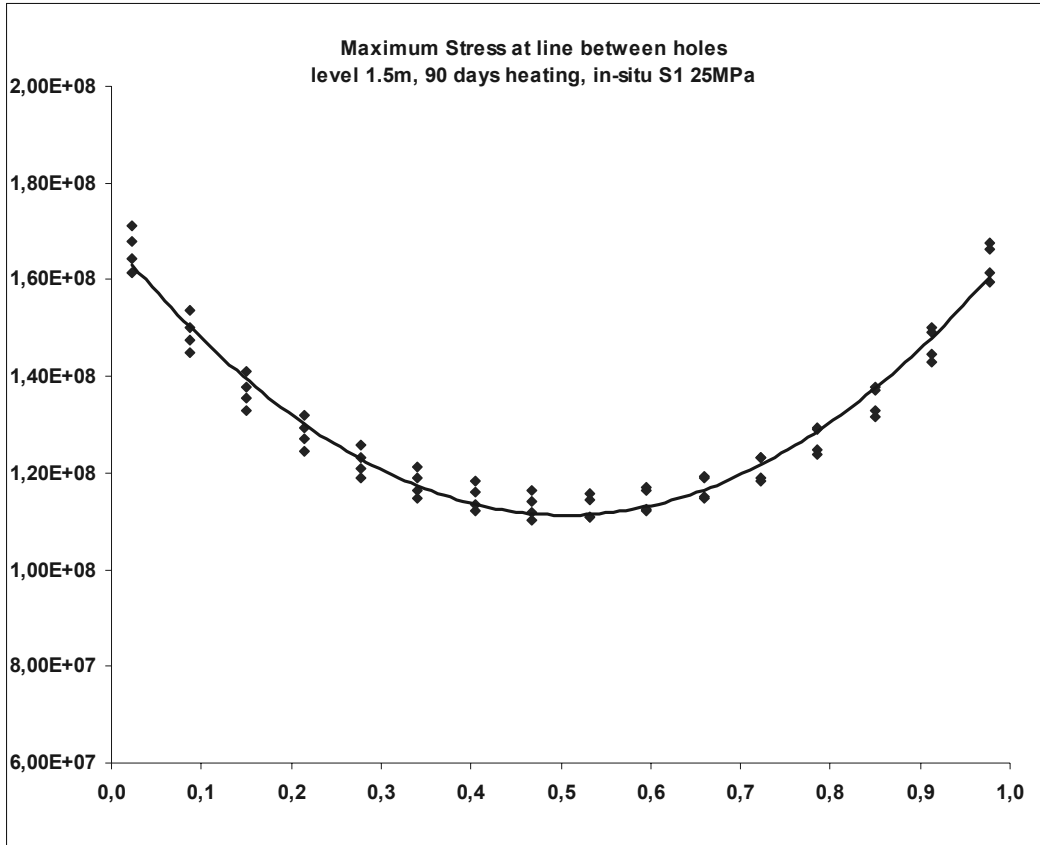
The report presents profile plots for the following cases and are mainly not presented in this appendix:

- Temperature profiles after 120 days heating for basic case on 0.5 m and 1.5 m levels
- Temperature profiles after 120 days heating for sensitivity analyses on 1.5 m level
- Stress profiles after 120 days heating for sensitivity analyses on 1.5m level.

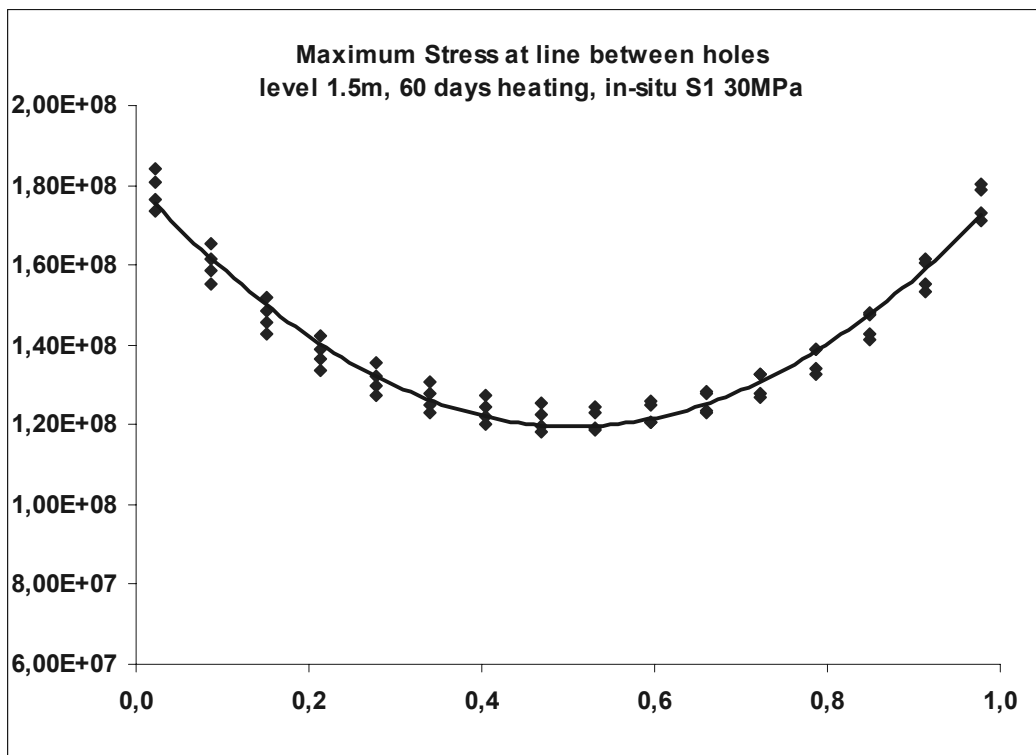
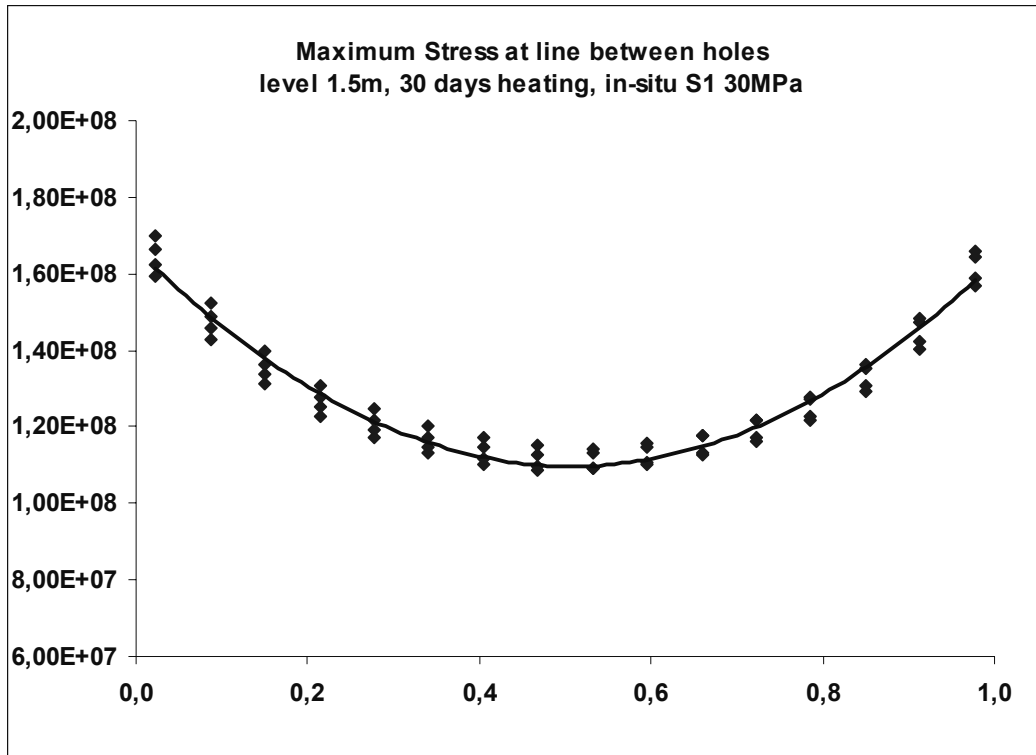
# 9.1 MODEL WITH SLOTS

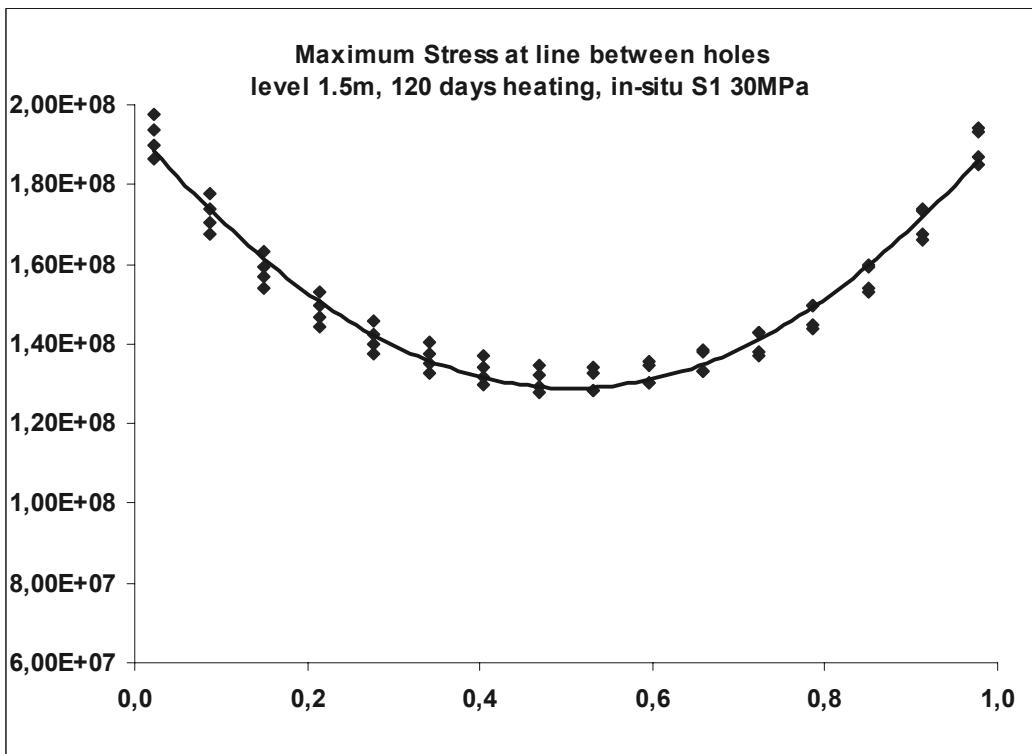
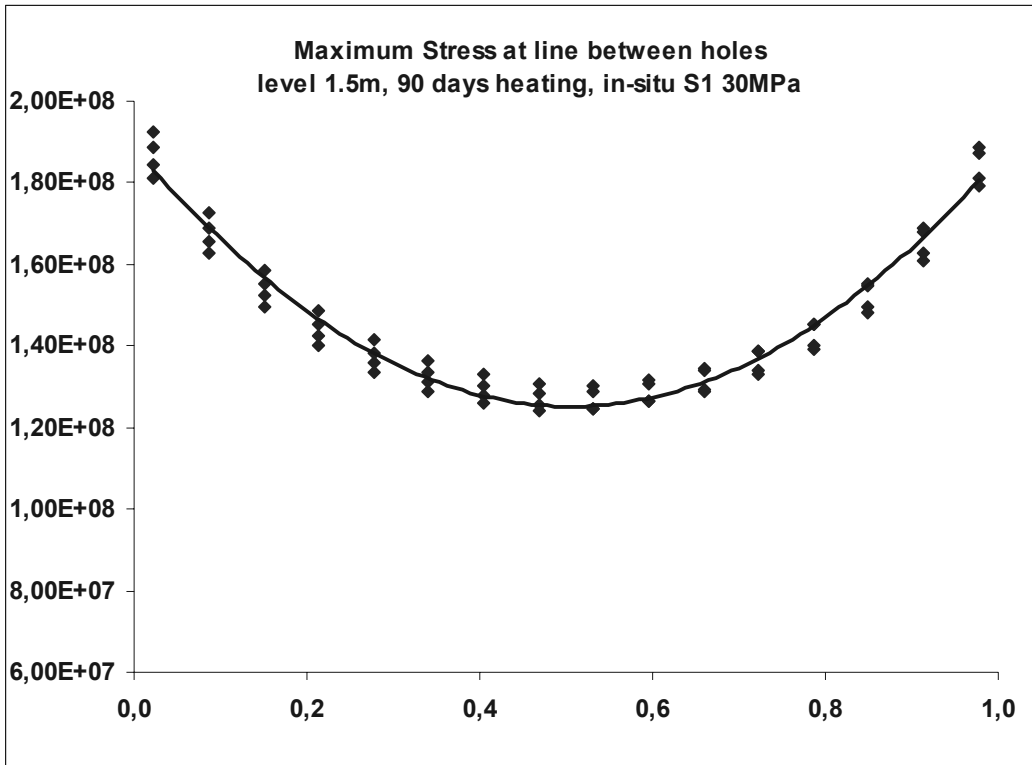
In-situ 25, 15, 10 MPa



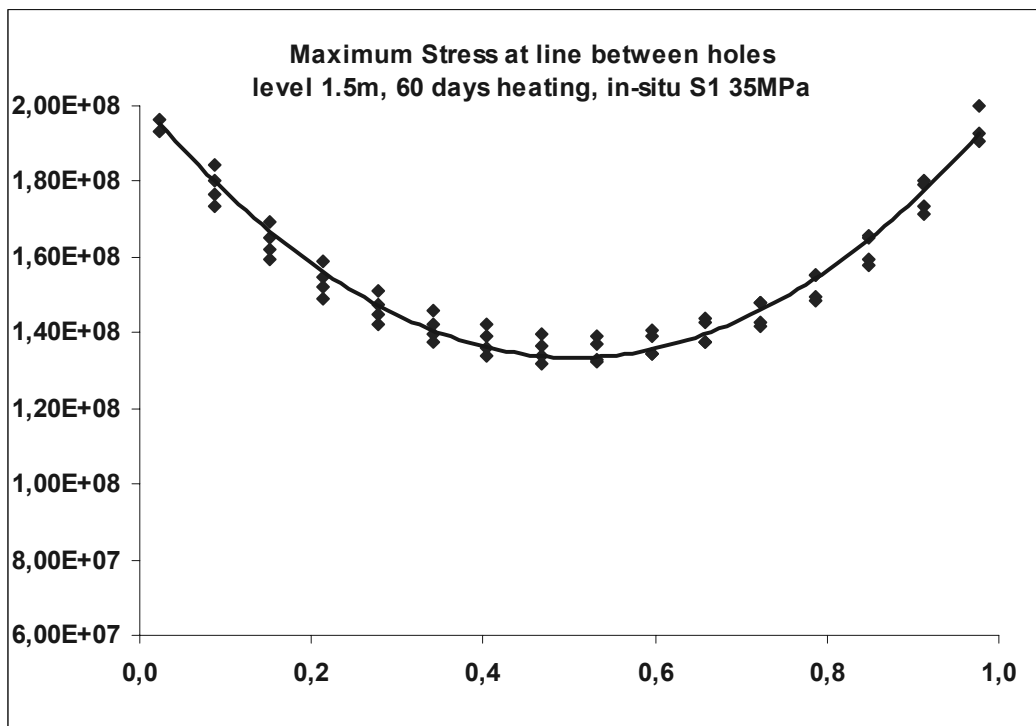
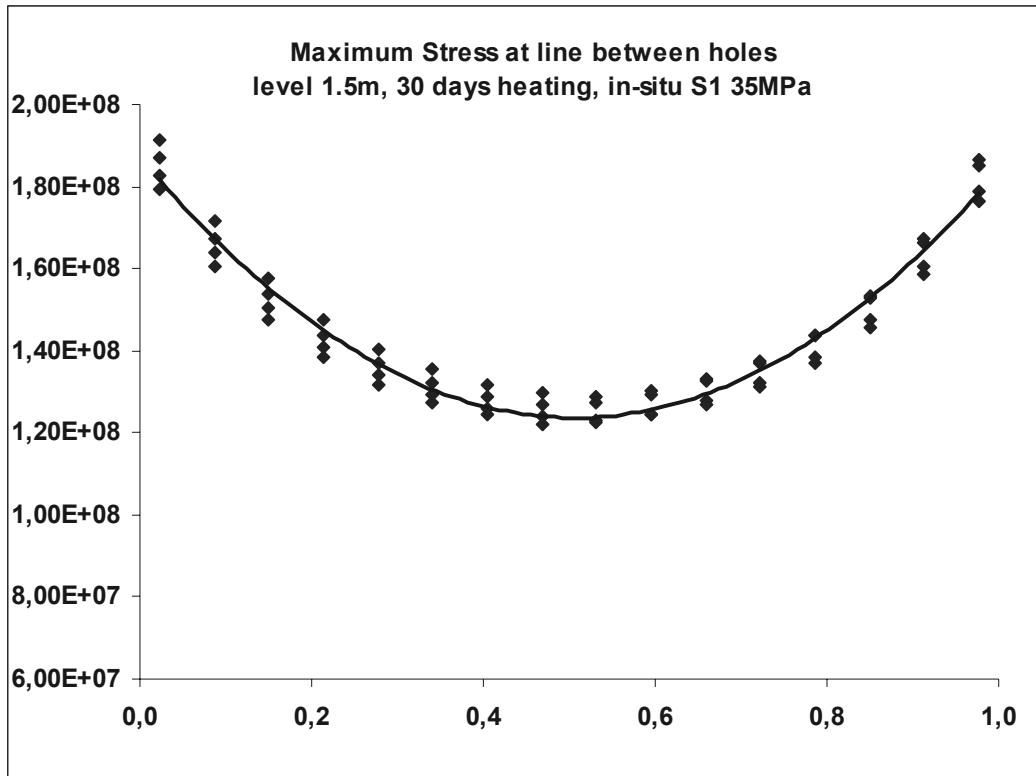


In-situ 30, 15, 10 MPa

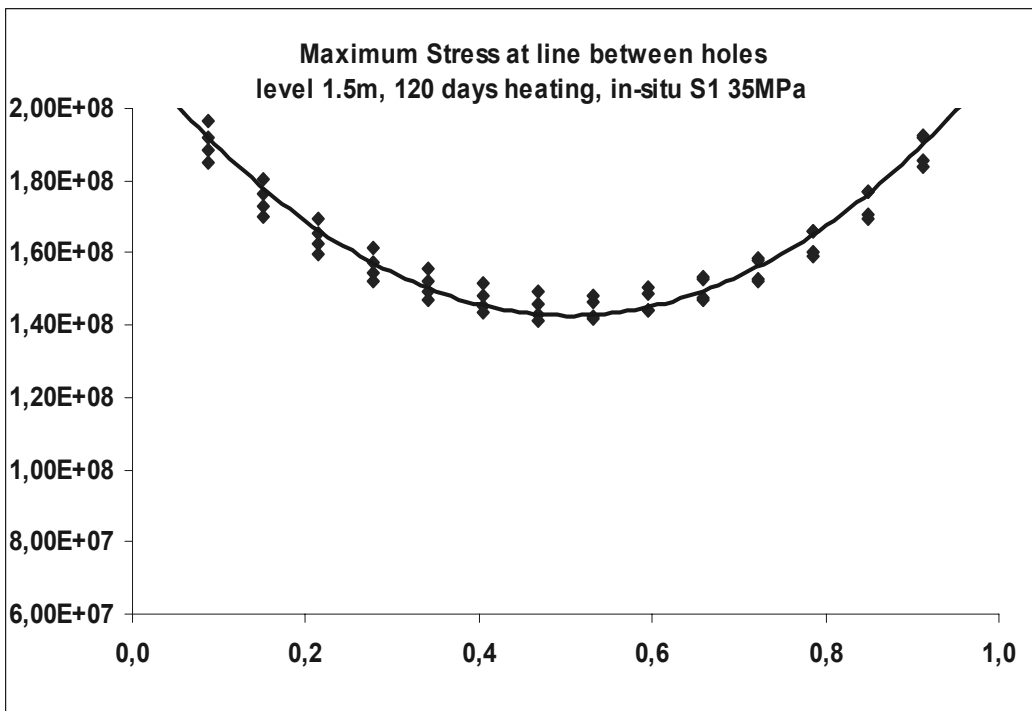
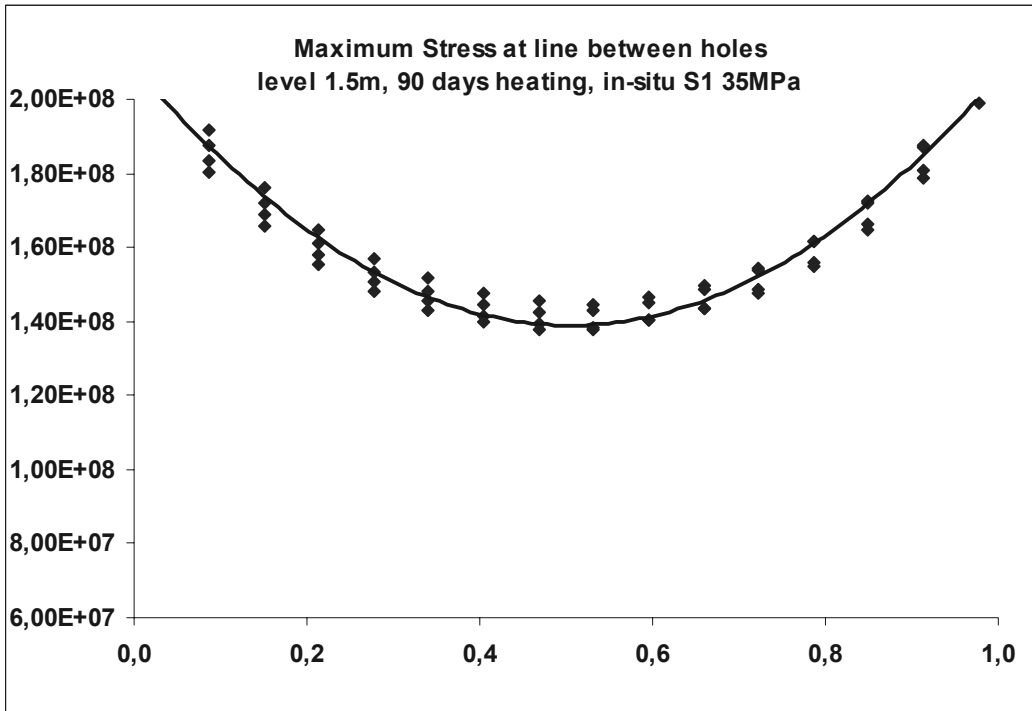




In-situ 35, 15, 10 MPa

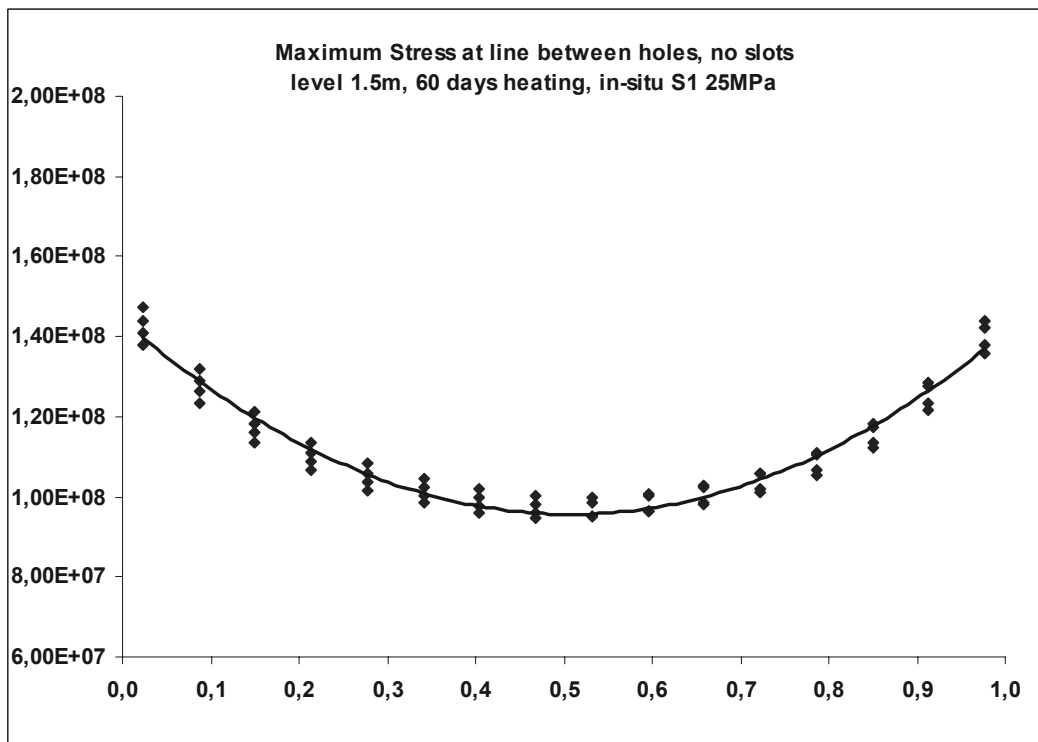
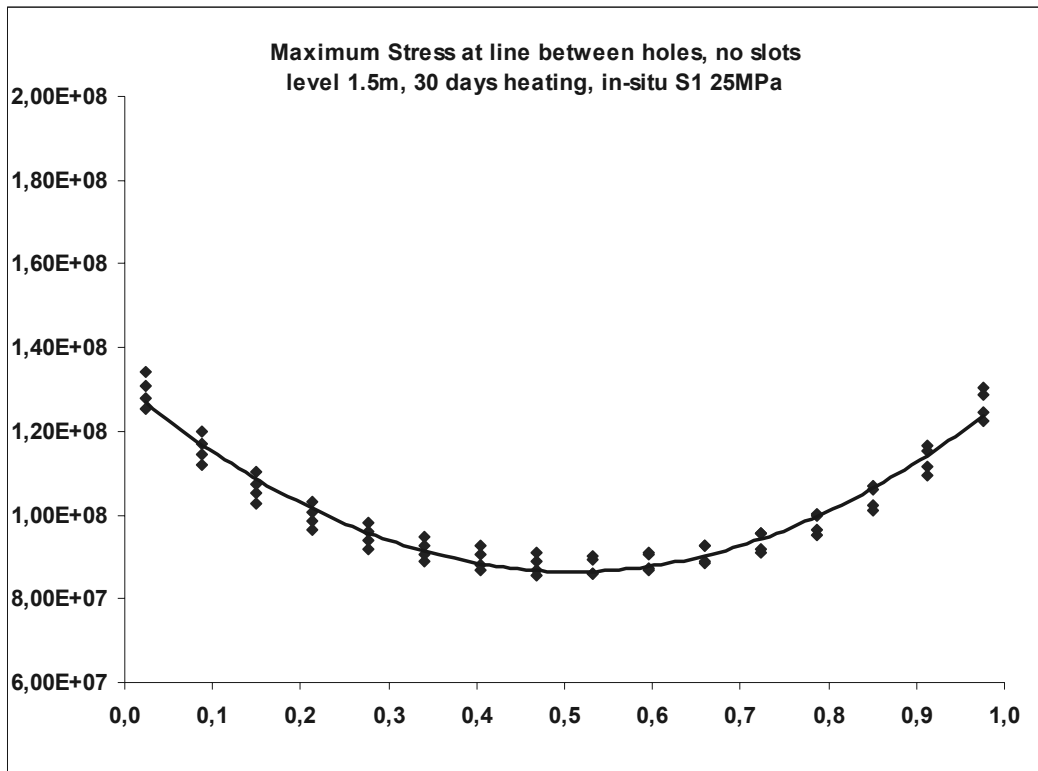


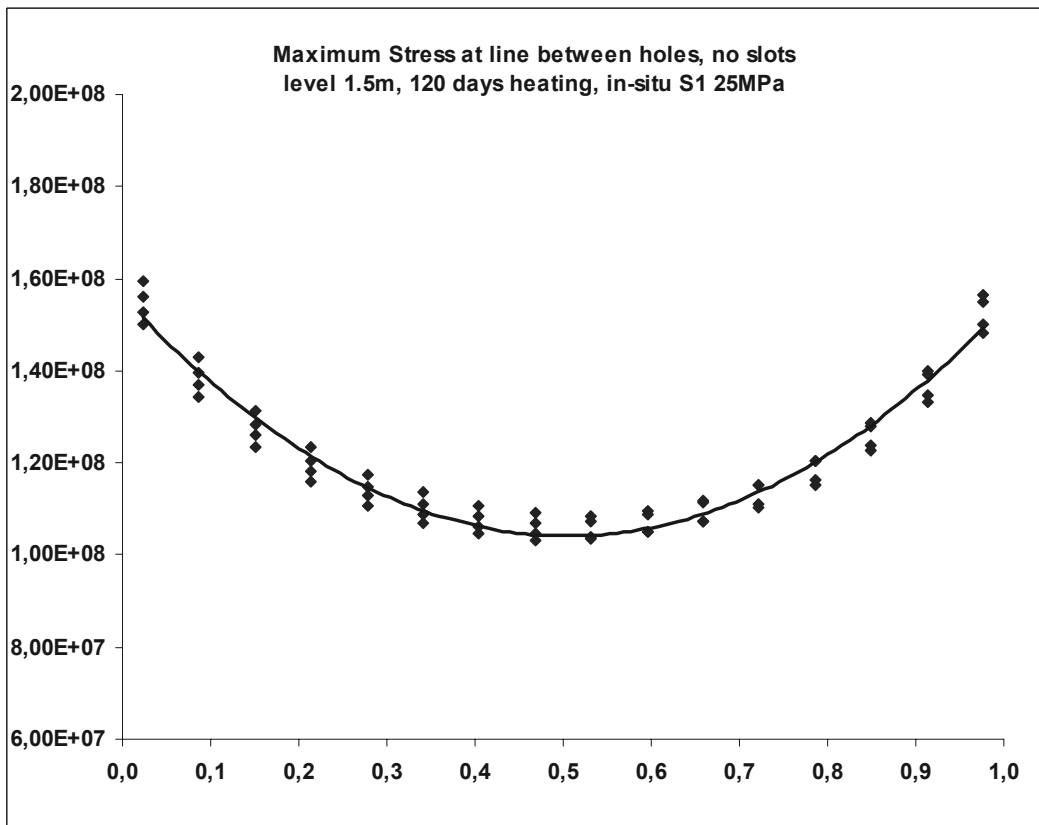
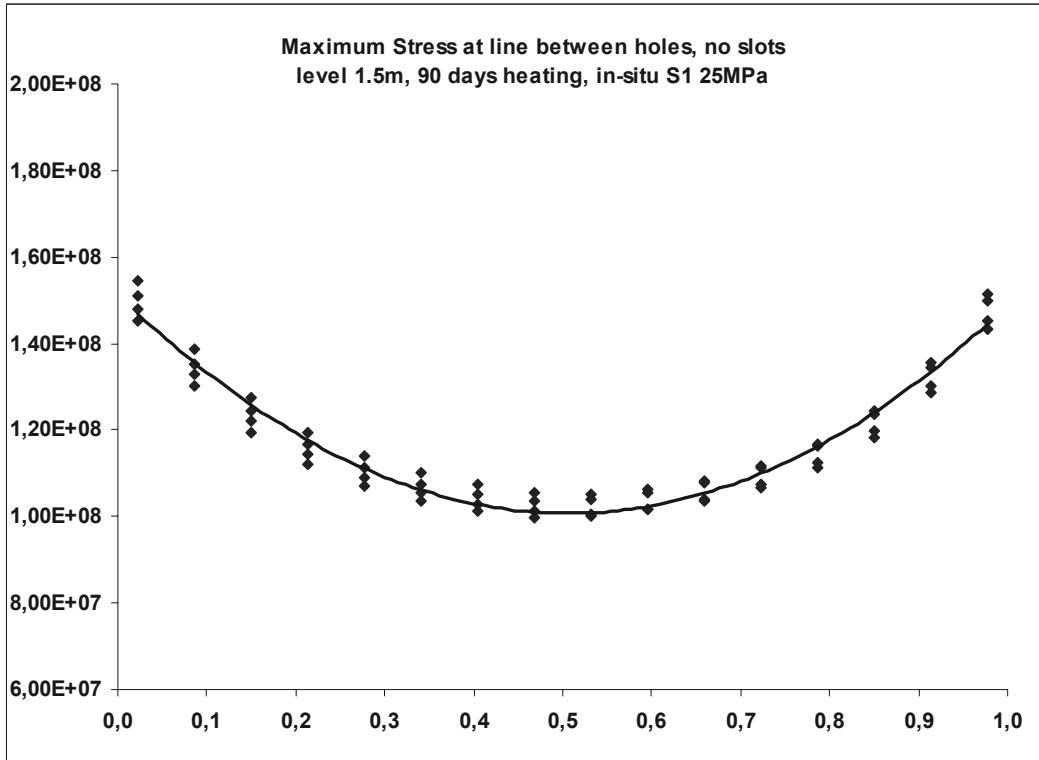




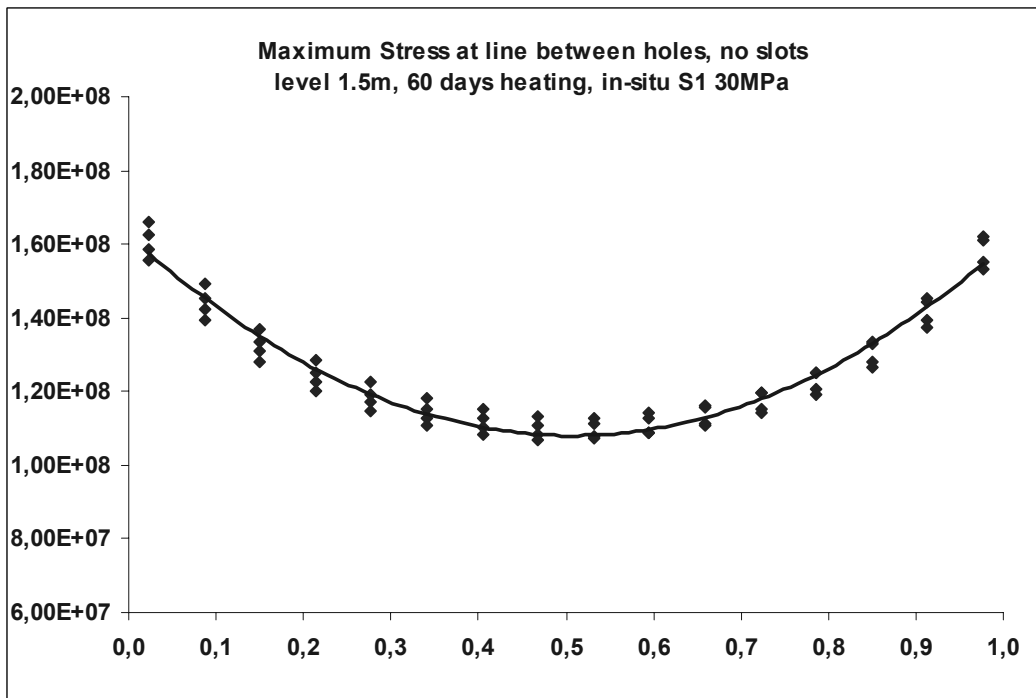
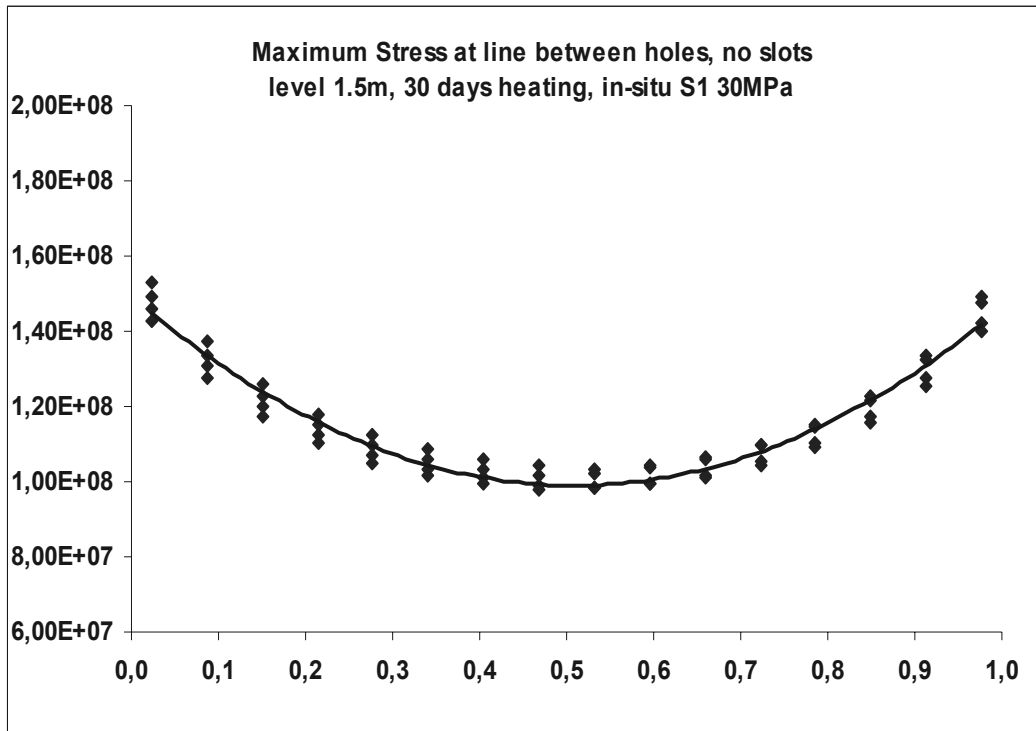
## 9.2 MODEL WITHOUT SLOTS

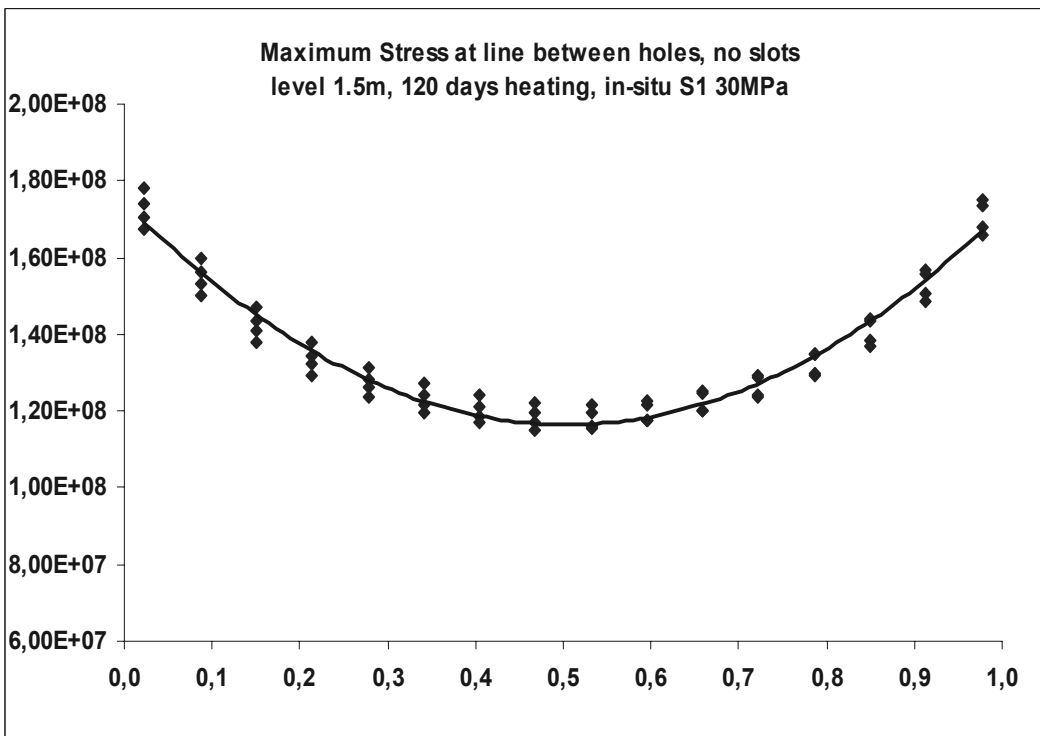
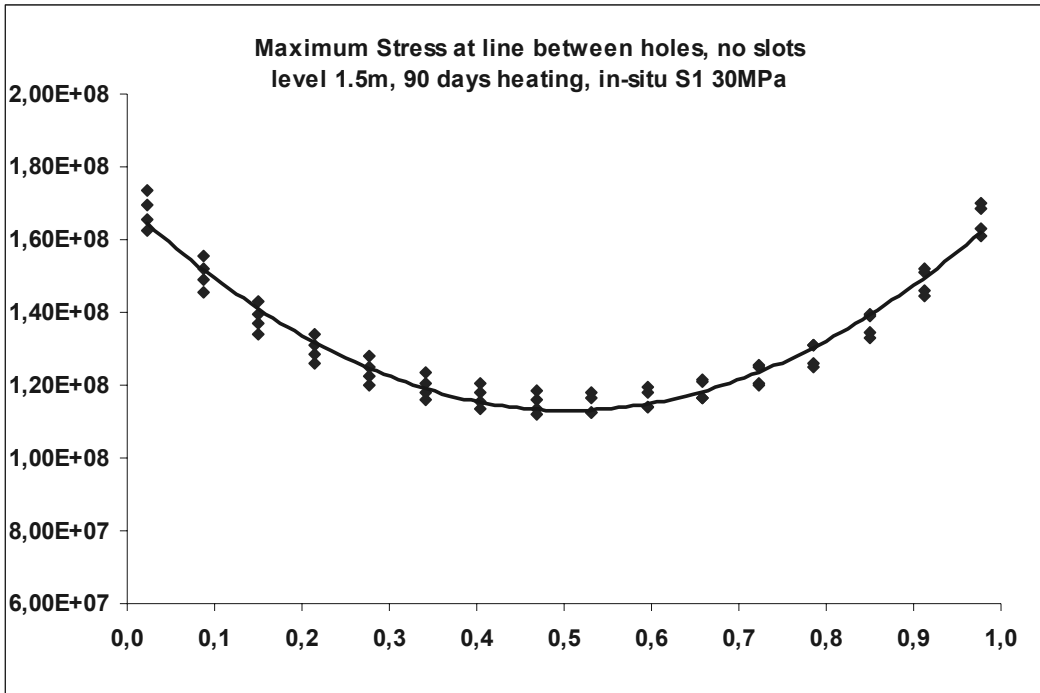
In-situ 25, 15, 10 MPa





In-situ 30, 15, 10 MPa





In-situ 35, 15, 10 MPa

