

**International
Progress Report**

IPR-03-18

Äspö Hard Rock Laboratory

Temperature Buffer Test

Feasibility study for the heating system at the TBT test carried out at the Äspö HRL in Sweden

J. L. García-Siñeriz

J. L. Fuentes-Cantillana

AITEMIN

October 2002

Svensk Kärnbränslehantering AB

Swedish Nuclear Fuel

and Waste Management Co

Box 5864

SE-102 40 Stockholm Sweden

Tel +46 8 459 84 00

Fax +46 8 661 57 19



**Äspö Hard Rock
Laboratory**

Report no.

IPR-03-18

Author

**J.L. García-Siñeriz,
J.L. Fuentes-Cantillana**

Checked by

Approved

**Bertrand Vignal
Christer Svemar**

No.

F12K

Date

02-10-02

Date

Date

03-03-03

Äspö Hard Rock Laboratory

Temperature Buffer Test

Feasibility study for the heating system at the TBT test carried out at the Äspö HRL in Sweden

J. L. García-Siñeriz

J. L. Fuentes-Cantillana

AITEMIN

October 2002

Keywords: Temperature Buffer Test, feasibility study, heating system

This report concerns a study which was conducted for SKB. The conclusions and viewpoints presented in the report are those of the author(s) and do not necessarily coincide with those of the client.

NATURE DU DOCUMENT : NATURE OF DOCUMENT: Report	Identification/ Identification: D.RP.AIT.02.001.B
--	--





Émetteur: <i>Originator:</i>	Repère support/Secrétaire : <i>Support ref./Secretary:</i> DRPAIT02001b.doc	Date d'origine : <i>Original date:</i> 03/10/02	Page <i>Page:</i> 1/19
--	--	--	-------------------------------------

FEASIBILITY STUDY FOR THE HEATING SYSTEM AT THE TBT TEST (Test de Barrière ouvragée en Température) CARRIED OUT AT THE ÄSPÖ UNDERGROUND LABORATORY IN SWEDEN

Documents associés / *Associated documents:*

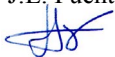
Titulaire / <i>Supplier:</i> 	N° du marché : <i>ANDRA contract or order number:</i> 022443PGR
Référence du titulaire : <i>Supplier's identification:</i> 95.05.8.19-01	Visa ANDRA pour diffusion <i>OK Andra for distribution</i> Nom / <i>Name:</i>

Ce document est la propriété de l'ANDRA et ne peut être reproduit ou communiqué sans son autorisation

Ind. <i>Ind.:</i>	Date : <i>Date:</i>	Nom et visa Rédacteur: <i>Written by:</i>	Nom et visa Vérificateur: <i>Reviewed by:</i>	Nom et visa Approbateur: <i>Approved by:</i>
B	19/12/02	J.L. García-Siñeriz J.L. Fuentes-Cantillana  	J.L. Fuentes-Cantillana J.L. García-Siñertiz  	J.L. Fuentes-Cantillana 



RÉVISIONS / REVISIONS	Identification / <i>Identification</i> : D.RP.AIT.02.001.B
	Page / <i>Page</i> : 2/19
	Rév. / <i>Rev.</i> : Emission mis à jour

Révisions / <i>Revisions</i>		Modifications / <i>Modifications</i>
Ind. / <i>Ind.</i>	Date / <i>Date</i>	
A	3/10/02	Emission initiale / <i>Original version</i>
B	19/12/02	Emission mis à jour / <i>Updated version</i>

ABSTRACT

The TBT experiment includes two heaters in the axis of the deposition hole, one on top of the other, separated by a compacted bentonite block. They are 3 m long and 610 mm in diameter, and are constructed in carbon steel.

The proposed design considers an outer body made with seamless tube with welded lids with a wall thickness of 50 mm, and an internal tube to support the electrical heating elements. These elements are tripled for redundancy, and each one of them is able to provide up to 2980 W. In addition, there are 6 thermocouples inside the heater for condition monitoring, and 11 thermocouples at different points of the external surface of the heater, which will be used for temperature control.

The power regulation system is based on static elements, and is independent for each heating element in order to improve the system reliability.

A specially dedicated data acquisition and control system will control the power regulation system and will provide information about temperatures and electrical parameters.

SAMMANFATTNING

TBT-experimentet omfattar två värmare i rad i ett vertikalt deponeringshål. De skiljs åt av ett förkompakterat bentonitblock. Varje värmare är 3 m lång, har en diameter på 610 mm och är tillverkade i kolstål.

Den föreslagna utformningen består av ett yttre, sömlöst rör med 50 mm godstjocklek och med svetsat lock och botten samt ett inre rör som bär upp de elektriska värmeelementen. Dessa element har tillsammans tredubbel effekt i jämförelse med behovet, och vart och ett är på 2980 W. Inne i respektive kapsel finns sex termoelement för övervakning av temperaturen i kapseln. Elva stycken finns på olika platser på kapselns ytteryta för kontroll av att den avsedda experimenttemperaturen hålls.

Kraftregleringen baseras på statiska element, och kan styra varje värmarelement för sig. Syftet är att få så bra tillförlitlighet som möjligt.

Ett speciellt utformat datainsamlingssystem och kontrollsystem kontrollerar kraftregleringssystemet, och tillhandahåller information om temperatur och elektriska parametrar.

INDEX

1	INTRODUCTION	5
2	BASIC SPECIFICATIONS.....	6
3	DESIGN CRITERIA	6
4	GENERAL DESCRIPTION	7
5	MECHANICAL CONSTRUCTION.....	8
6	ELECTRICAL PARTS	10
6.1	Heating elements.....	10
6.1.1	Power requirements.....	10
6.1.2	Characteristics of the heating elements	10
6.1.3	Internal thermocouples.....	12
6.1.4	Cable through-pass.....	12
6.2	Power regulation system	13
7	INSTRUMENTATION AND CONTROL	14
7.1	External thermocouples.....	14
7.2	Control System.....	15
7.2.1	Functions and structure	15
7.2.2	PID modules.....	17
7.2.3	Data logging unit.....	17
7.2.4	Host Computer	17
7.2.5	Uninterrupted Power Supply	18
8	QUALITY CONTROL	18
9	COSTS.....	19

Annexes:

Annex 1: Mechanical modelling

Annex 2: Drawings

1 INTRODUCTION

ANDRA is planning to carry out an underground test identified as “TBT” (*Test de Barrière ouvragée en Température*) at the Äspö underground laboratory in Sweden.

A basic layout of the test is shown in Figure 1. It includes two heaters in one common vertical deposition hole. Each one simulates a different type of confinement system: a bentonite buffer only (bottom section) and a bentonite buffer with inner sand backfill (upper section).

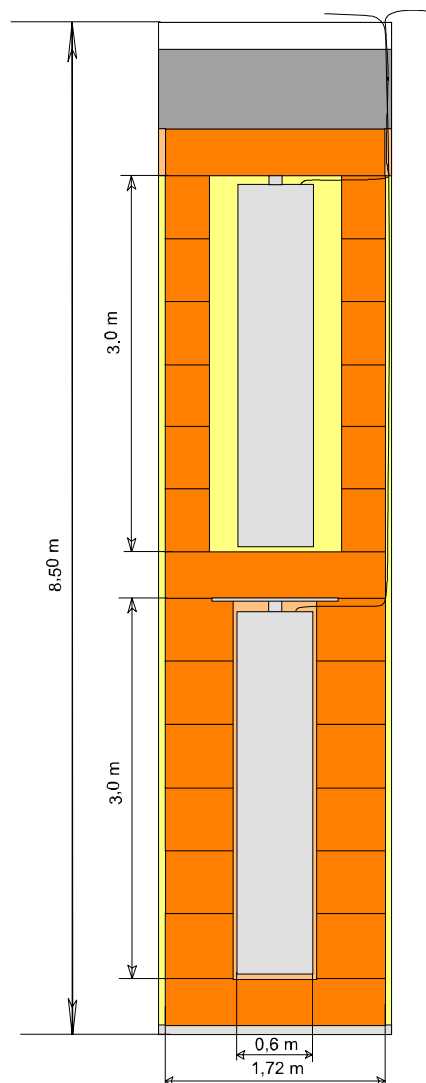

Figure 1: Basic layout of the TBT (conceptual)

The present document, which has been produced under the ANDRA contract No. 022443PGR, refers to the basic design of the heating elements and provides the specifications required for manufacturing.

2 BASIC SPECIFICATIONS

The basic specifications from ANDRA for the heaters design are the following:

Shape:	Cylindrical
Total length:	3 m
Diameter:	610 mm*
Power	Peak 700 W/m**
Casing material:	Carbon steel
Max. surface temperature:	225 °C
Max. external pressure***:	12 MPa
Test duration	7 years

Notes:

(*) Initially established at 600 mm, has been increased up to 610 mm to simplify the mechanical construction

(**) Initially 600 W/m, has been upgraded to 700 W/m to handle predicted power peaks

(***) Combination of bentonite swelling pressure plus expected pore pressure in the buffer

Other requirements

- The two heaters must be mechanically independent to enable the possibility of carrying out a separate retrieval of the units in the future.
- Power regulation should be independent for each unit
- The heaters should include all the instruments and components required for power regulation
- Cables and/or tubes should be taken out from the heaters in a direction perpendicular to their axis

3 DESIGN CRITERIA

From the different possible options, the adopted technical solution is that of two electrical heaters, constructed as fully independent units, and placed one on top of the other as shown in the Figure 1. This solution has the following advantages:

- It is simple and reliable. The life of the electrical resistors may be extended with an adequate design (de-rating) and by installing redundant elements.
- Connections are minimized and can be constructed in a gas-tight mode. They can be flexible, and have a reduced diameter.
- There are no moving parts of fluids as it would be the case for instance of oil heaters. Tubes and other hot connections are avoided.
- Power regulation system can be done easily using electronic systems requiring minimal maintenance.

The only disadvantage of this configuration is the impossibility of servicing the heating units once they are put in place. However, this can be compensated by increasing the reliability of the critical elements (i.e. the heating resistors). As a reference, the heaters used in the FEBEX experiment, that were designed and constructed with the same philosophy, have been in operation for more than 5 years (and the remaining one still goes on) without any problem.

4 GENERAL DESCRIPTION

The basic constructive characteristics of the heaters would be the following:

- Mechanical construction: Each heater will be constructed in a fully closed cylindrical body made on carbon steel with welded lids, in order to avoid joints. The inner part of the container will be filled with inert gas to remove the air inside and hence minimise internal corrosion.
- Electrical design: Shielded heating elements shall be placed inside the heaters in such a way that the heat distribution is uniform. The elements will be redundant by a factor of three for enhanced reliability. The connection cables will come out through the upper lid using high temperature gas-tight cable entries. These elements will have a continuous metal sheath along its full length, till the connection box in the gallery, in order to avoid connections both inside the heaters and in the buffer area. A number of temperature sensors will be installed inside the heaters to monitor the internal temperature.
- Power regulation system: Independent static power regulation systems will be installed for each resistor element. Each circuit would be galvanically isolated to reduce the effects of potential isolation failures. Power control will enable both constant power and constant temperature control modes, and will use phase-angle regulation mode to minimise mechanical stresses in the heating elements. A number of temperature sensors will be placed in the outer surface of the heaters to serve as reference for the power regulation system when working in the constant temperature mode. These sensors will be redundant by a factor of three.

5 MECHANICAL CONSTRUCTION

A general view of the mechanical construction of the heaters is shown in Figure 2. The outer container will be made with a seamless tube and two welded lids. The wall thickness of the outer container is 50 mm, whereas the lids are a bit thicker.

An internal tube with an outer diameter of 457,2 mm will be mounted inside, to serve as support for the heating elements. These will be wound around this tube and fixed to it with metal brackets. The gap between both tubes is 26,4 mm. A number of spacer blocks will be fixed to the inner tube to center it and to protect the heating elements during the assembly process.

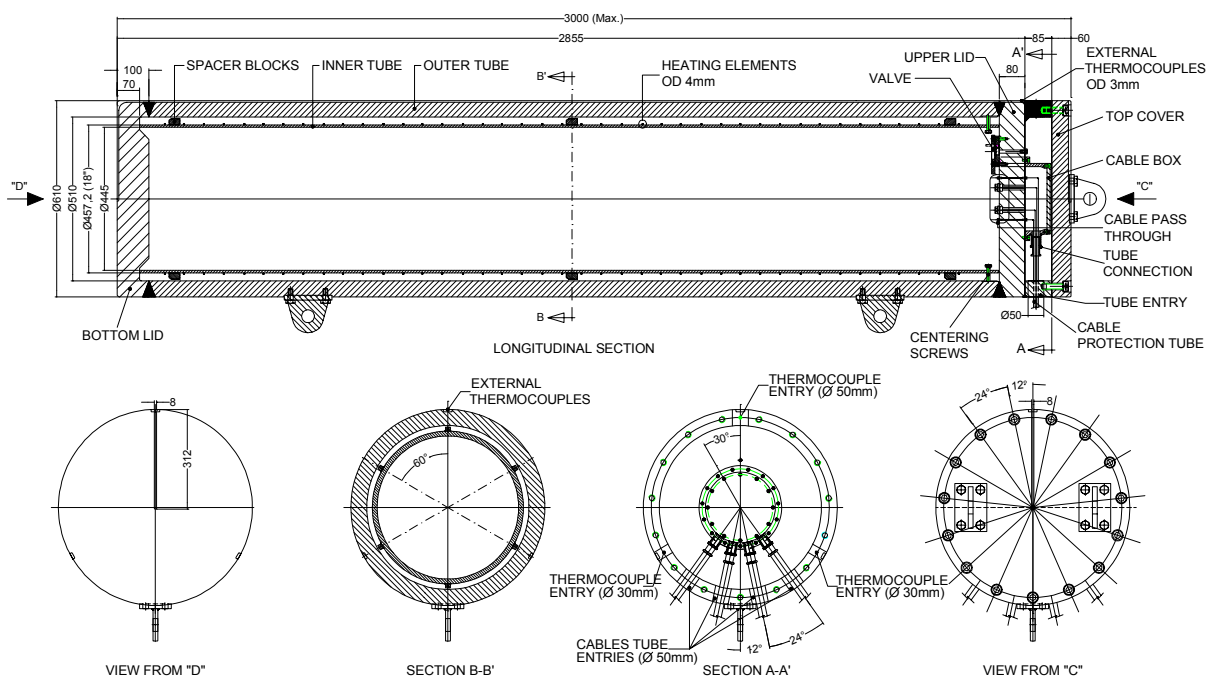

Figure 2: Heaters construction

The cold terminals of the 3 heating elements will be taken out of the main body across holes drilled in the upper lid. These will be sealed by means of compression glands and a high temperature epoxy compound (see section 6.1.4). A similar solution will be adopted for the six internal thermocouples. The tightness of the heater body is guaranteed by these seals.

At the outer part of the upper lid there is a double enclosure:

- The first enclosure is a water tight box used for conducting all the metal sheathed cables (heating elements and internal thermocouples) into copper tubes that protect these cables along their way through the buffer and up to the service gallery. The main function of these tubes is to provide mechanical protection, but they also give to the cables an additional protection against water, serve as electric ground connection and

reduce the EMI that could be generated by the power cables. The terminal box will be filled also with a high temperature epoxy compound for improved tightness.

- The second enclosure is basically a mechanical protection for the terminal box and cables, and will support the weight of the upper heater (or bentonite blocks). This enclosure is not water-tight, and will be filled with 4 mm diameter glass balls to enable water inflow but to prevent the ingress of bentonite.

The basic mechanical characteristics of the heaters are given in Table 1.

Table 1: Basic mechanical characteristics of the heaters

External Dimensions	Diameter	610 mm
	Length	3 m
	Total weight (estimated)	3 000 kg
Outer body	Wall thickness	50 mm
	Material	Carbon steel
Inner tube	Outer diameter	457 mm
	Thickness	6 mm

Annex II includes a more detailed drawing of the mechanical construction of the heater.

The basic structure of the heater has been modeled to validate the soundness of the mechanical design and to anticipate maximum stresses and deformations. This work, included as Annex I, has been carried out by the Department of Applied Mathematics and Informatics of the Polytechnic University of Madrid - School of Mines, and considers the stresses and deformations induced by both the expected thermal conditions plus the external pressure onto the heater. As can be seen from the results, both maximal stresses and deformations are well below limit values.

6 ELECTRICAL PARTS

6.1 Heating elements

6.1.1 Power requirements

According to the specifications provided by ANDRA, the power required to reach the target temperature of 225 °C at the external part of the heater is 600 W/m, but it is expected that in some phases of the experiment power peaks of up to 700 W/m may be required. Considering a safety factor of 1,4 on this last figure, the resulting power for design purposes is 980 W/m. In principle, there will be three independent heating elements for redundancy reasons, and each one of them should be able to provide such power.

6.1.2 Characteristics of the heating elements

Each heating element will be a mineral insulated heating cable, composed by three parts: the heating cable, two cold ends and two connection cables (see Figure 3).

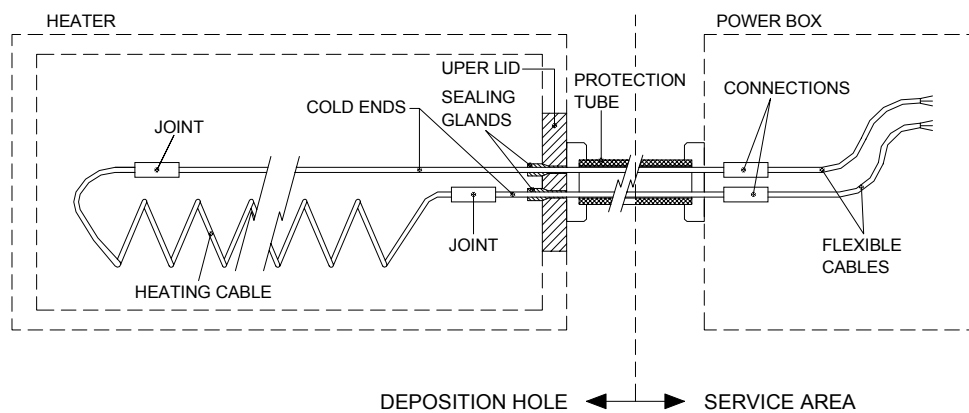

Figure 3: Layout of the heating elements

The heating cables will have a metallic sheath along their full length, made on Inconel 600 and with an external diameter of 4 mm. The active part has a resistor core made in Tophet (80% Ni, 20% Cr) and the insulation is made of compressed magnesium oxide. This part will be about 25 m in length for each heating element and will be wound around the heater inner tube, with a separation between turns of about 150 mm (see Figure 4).

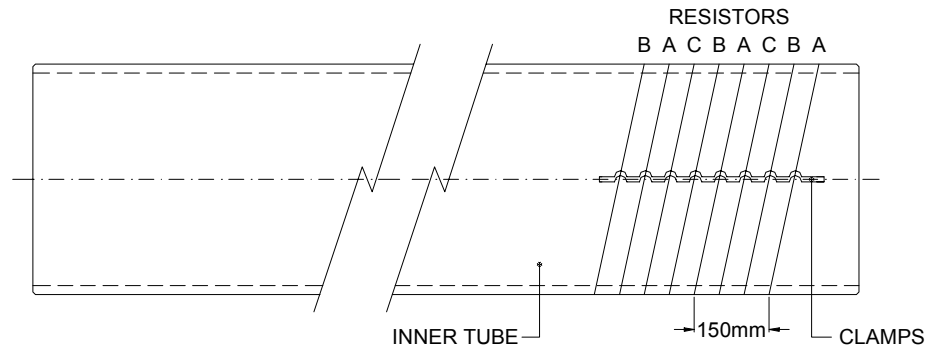

Figure 4: Disposition of heating elements on the inner tube

The cold ends have the same sheath and insulation than the active part, but have a low resistance core. The cold ends will be taken out of the heaters across cable through-passes in the upper lid and then introduced into a protection tube made in copper, all the way from the heater body to the gallery (see Figure 3). There will be one tube for each heating element and an additional tube for the six internal thermocouples. The tubes will be laid horizontally up to slots excavated in the surface of the deposition hole, and taken vertically by this way up to the gallery. The length of the cold ends has been calculated for reaching the wall of the gallery in the nearby of the deposition hole (about 3 m from the concrete plug)

The internal joints making the connection between the heating cable and the cold end provides an adequate continuity of the Inconel 600 sheaths, having the same diameter as the cables (4 mm).

Table 2 summarizes the basic characteristics of the heating elements.

Table 2: Characteristics of the heating elements

		Active part	Cold ends
External diameter		4 mm	4 mm
Sheath material		Inconel 600	Inconel 600
Insulation		MgO	MgO
Core Resistance (20 °C)		0,78 Ω/m	0,04 Ω/m
Continuous service temp.		>600 °C	> 600 °C
Length	Lower unit	25 m	15,5/13 m
	Upper unit	25 m	12/9,5 m

At the end of the metal sheath, a connection is made to a standard Teflon insulated flexible cable. This connection is made encapsulated with an external diameter of about 10 mm and a typical working temperature up to 200 °C, and will be located inside a cable connection box at the service gallery (see Figure 3).

6.1.3 Internal thermocouples

Six thermocouples will be installed inside the heater to monitor the temperature conditions inside the unit. These will be type “J” thermocouples class 1 (range 0-750 °C), calibrated at 4 points: 0, 100, 225 and 350 °C. Two thermocouples will be installed at 200 mm from each end of the inner tube, at opposite sides, and the third pair will be placed in the middle of the heater. All thermocouples will have the same sheath than the heating elements (Inconel 600), with an outer diameter of 3 mm.

6.1.4 Cable through-pass

The six cold ends of the heating elements and the six internal thermocouples will be taken out of the heater body across through-pass holes drilled on its upper lid. Tightness will be achieved using ¼” NPT cone-shaped compression glands made on AISI 316L stainless steel, certified to operate up to 400 °C and 200 bars. The holes will be also sealed on their outer part with a high temperature epoxy compound that has a working temperature over 250 °C (see Figure 5).

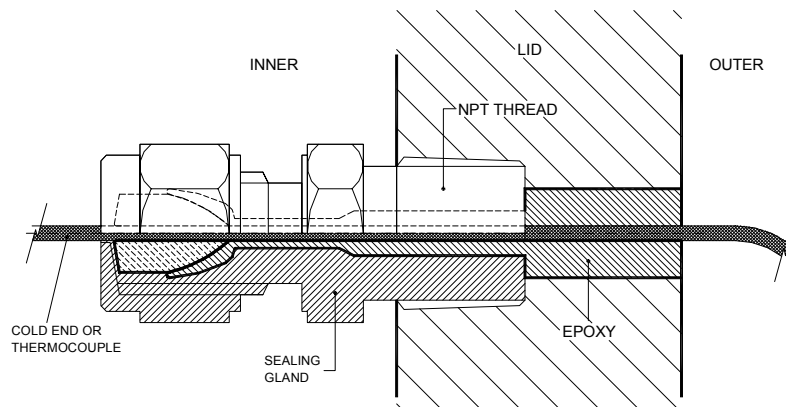

Figure 5: Cable through-passes on the heater upper lid (not to scale)

After crossing the upper lid, the heating elements cables and the internal thermocouples will be introduced into protection tubes made on copper (one for each heating element and one for the six thermocouples), coupled to the cable exit box. This box, and the horizontal section of the protection tubes, will be also sealed with the high temperature epoxy compound for enhanced tightness.

6.2 Power regulation system

The power regulation system will be based on single-phase static regulators, operating in phase angle mode, in order to minimise thermal stresses at the heating elements.

Each heating element unit will be powered from a different mains phase and will have a fully independent power regulation channel. For each channel, the circuit will comprise the following components (see Figure 6):

- Overload and short-circuit protections
- Galvanic isolation transformer
- Voltage presence relay
- Ultra-fast fuses for the semiconductor components
- Thyristor module
- PID controller
- Voltage and current indication (true RMS values)
- Insulation monitor
- Local set-point selector (key protected)
- Set-point and actual maximum external temperature indications
- EMC filter at mains and output

Each thyristor module will be controlled by a PID auto-tuning module. The normal mode of operation will be “constant power”: The PID controller receives an external set-point in power and a feedback of the actual power applied to the heater, and adjusts the power in the heating element by regulating the voltage applied to the element, so to keep the power constant at the set-point value.

The maximum temperature at the heater surface will be limited to 225°C and for that purpose the controller receives inputs from all the thermocouples installed at the outer surface of the heaters and selects the highest temperature among them. When the limit is reached the operation mode will change automatically to “constant temperature” and the highest temperature will be used as feedback reference for the control loop.

Alternatively, the system can also operate in “constant temperature” mode at any time.

The set-point value (target power or temperature depending on the control mode selected) will normally be provided by the computer system (remote control), as a function of the experiment needs. In case of failure of the computer system or because of functional reasons, it is also possible to adjust manually the set-point at the power regulation unit.

The actual voltage applied and current consumption of each heating element (true RMS values), as well as the isolation to earth, will be measured by means of electrical signal converters. These converters will provide a 4-20 mA output that will be used for local indication and also as an input to the data acquisition and control system.

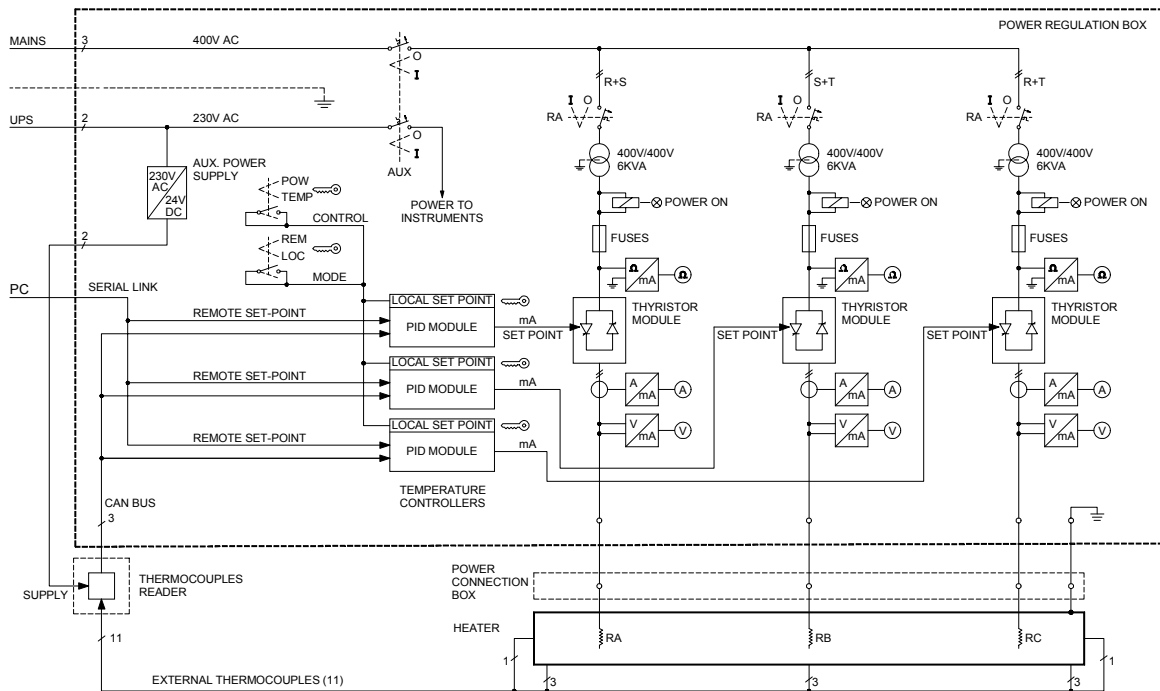

Figure 6: Power regulation system

7 INSTRUMENTATION AND CONTROL

7.1 External thermocouples

The external temperature of the heaters will be measured by eleven type ‘‘J’’ class 1 thermocouples (range 0-750 °C) calibrated for 4 points: 0, 100, 225 and 275 °C. Three groups of three thermocouples, will be installed at 120 mm from each heater end, and at the middle of the heater, with a disposition at 120°. Two additional thermocouples will be installed in the centre of the bottom lid and the top cover.

All thermocouple will have a sheath of the same material as the heating elements (Inconel 600), with an outer diameter of 3 mm. Additionally, they will be protected against corrosion by means of a 6 mm outer diameter copper tube up to the gallery surface. The active junctions of each thermocouple will be provided with a stud termination in order to screw or bolt the end to the heater surface. The thermocouples will be installed in 7,5 mm deep grooves machined along the heater body external surface. At the upper part, they will be taken to the top chamber across entries drilled also at 120°. From this chamber they will be laid across the bentonite buffer up to a slot excavated at the surface of the deposition hole, orientated opposite to the slot corresponding to the power cables. (see Figure 7).

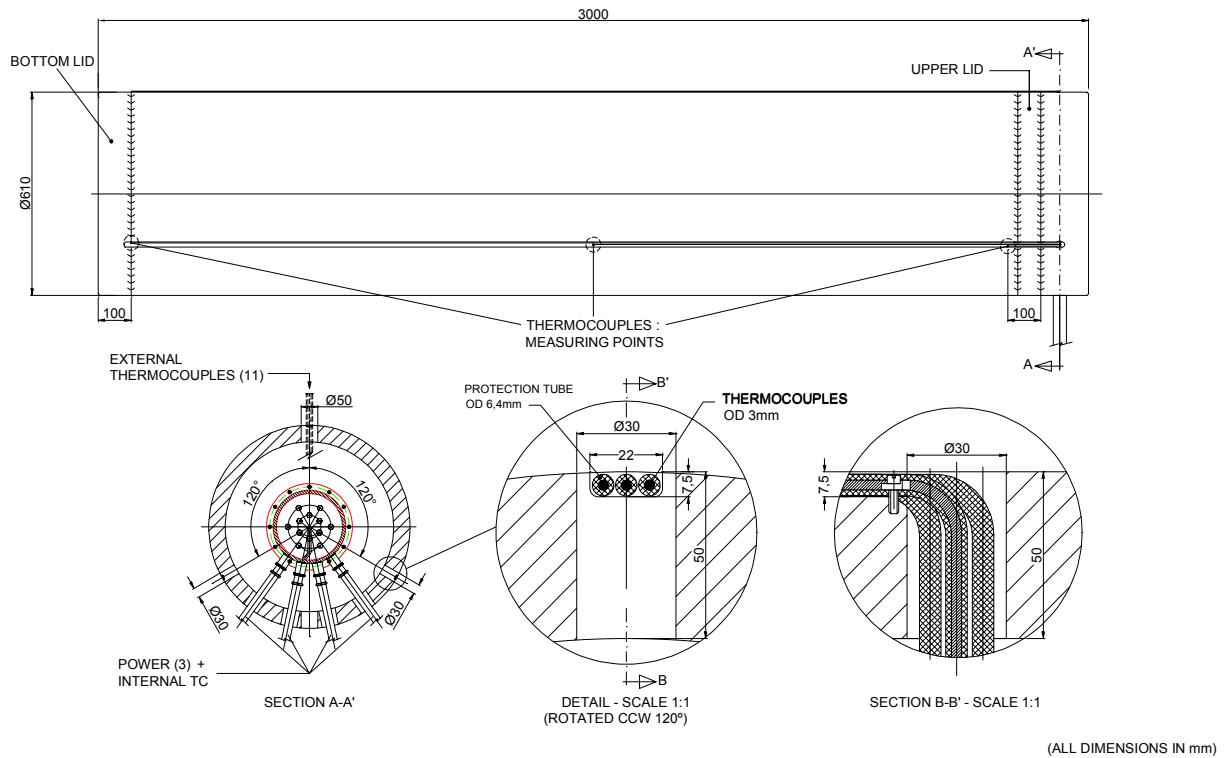

Figure 7: Layout of external thermocouples

7.2 Control System

7.2.1 Functions and structure

The functions of the dedicated data acquisition, display and control system (DADCS) will be the following:

1. To acquire, store and display the information provided by the installed instruments (thermocouples and electrical signal converters)
2. To generate the commands required at each moment for the power regulation, upon the basis of the experiment control strategy.
3. To transfer information to the general data acquisition system installed at Äspö
4. To enable remote access to the system via modem for remote monitoring and maintenance.

The DADCS will be composed by the following main components:

- Signal conditioning and data logging unit
- Host Computer (PC)
- Uninterrupted Power Supply unit

An overview of the DADCS structure is shown in Figure 8. The following sections describe the main components of the system.

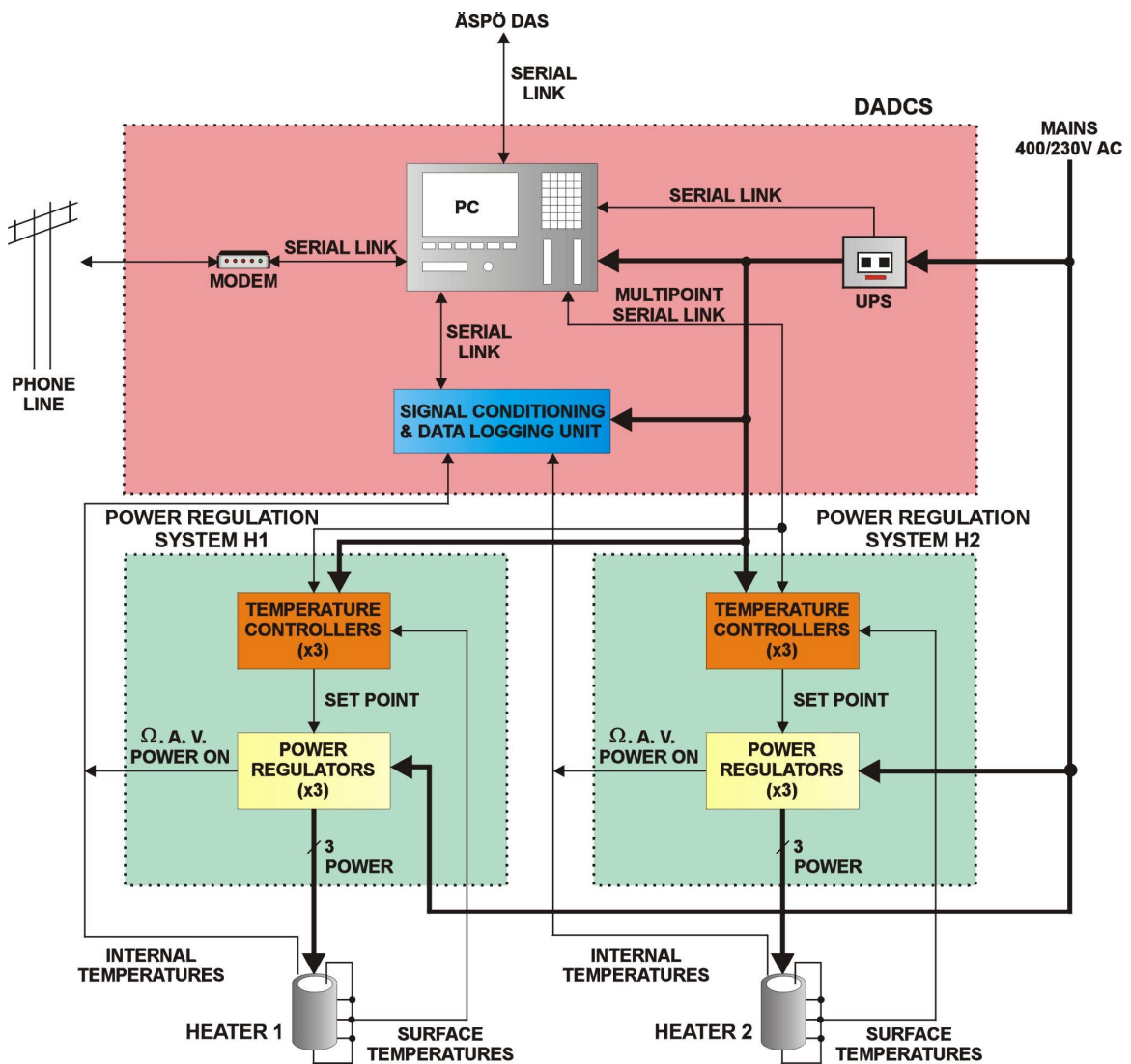

Figure 8: Structure of the data acquisition, display and control system (DADCS)

7.2.2 PID modules

This will receive the signals from almost all the installed instruments (except for heaters internal thermocouples that will be read by the data logger). The signals connected to this unit are:

- Current, voltage and isolation from each heating element (3 analog signals 4-20 mA type)
- Working mode (remote/local) and control mode (power/temperature) for each heater power regulation system (2 digital signals), and power on/off and isolation defect for each resistor (2 additional digital signals)
- Heaters external temperatures (11 analog signals mV type) that are indeed read by a dedicated data converted attached to the PID modules by a high sped can bus.

These signals will be digitised, processed and transmitted to the host computer by a serial link.

7.2.3 Data logging unit

This will be a general conditioning/acquisition and data logging unit that will receive the signals from heaters internal thermocouples.

These signals will be digitised, stored in the internal memory, and transmitted to the host computer by a serial link. The internal data logging capability of this unit provides a redundant storage of data, enabling the recovery of the information in case of PC failure. The information can be recovered totally or in part, depending on the scan rate, memory size and failure duration.

7.2.4 Host Computer

The host computer will be a standard industrial computer (rugged PC). The PC will read the data from the PID modules and the logging unit, and will process, display, and store these data in an internal data base. The computer also will generate the power or temperature set point for the heater power regulation units, as a function of the programmed control strategy, which could be configured and adapted to each situation either locally or remotely. Finally all these data will be transmitted to the general Data Acquisition System of the Äspö laboratory by means of a OPC server.

A general purpose SCADA firmware will be used to perform the following main functions:

- Continuous data acquisition from PID modules and the data logging
- Data conversion into physical units
- Adaptation of conversion functions

- Data presentation (text and graphical)
- Data storage into internal data base
- Heaters set point calculation and writing to the power regulation units
- Display of heaters status and alarms generation

The data base at the PC will contain the values of the measurements in principle each ten minutes period. However this rate can be modified if necessary at some specific moments, for example during the start-up period.

Remote access to the host computer will be possible via standard telephone network using an adequate modem and a well proven dedicated communications firmware. This will enable to perform the heater control remote supervision, to dump stored data, and to modify the power control strategy, if necessary.

The access (by keyboard or by modem) to the computer will be restricted by means of a specific entry password.

7.2.5 Uninterrupted Power Supply

The PC, the data logging unit, the power controllers and the auxiliary power of the power regulation system will be backed-up from an Uninterrupted Power Supply (UPS). In case of mains network shutdown, the UPS will guarantee the power supply to these devices for a 10-15 minutes time period.

The UPS will have a built-in firmware which enables to perform the UPS supervision from the host computer. For that purpose the UPS will be connected to the PC via a RS-232 serial link. The UPS will work in the “on-line” mode (output voltage is separated from input and battery-buffered), minimising disturbances from mains network.

8 **QUALITY CONTROL**

a) Mechanical construction

The construction of the heater body will be carried out according to AD-Merkblatter (DIN) code, at a mechanical construction plant having a certified ISO quality system and certified procedures.

All the main welding cords will be thermally treated for stress release. The ones in the main lids, will be inspected by NDT techniques (X-ray, magnetic particles, eddy currents, ...).

A helium test will be carried out once the main body is assembled, to test the tightness of the cable pass-through. This test will also be used to check the upper lid welding, as X-ray inspection is not feasible in this case.

b) Electrical components

The heating elements and the thermocouples will be purchased to a manufacturer having a certified ISO quality system. Length, Resistance and insulation checks will be carried out on reception.

c) CE marking

The complete heating system will be designed and assembled to comply with LVD 73/23/EEC (Low Voltage Directive) and a Declaration of Conformity will be provided concerning the applicable standards: IEC605519-1 (1984-11) & IEC60519-2 (1992-01).

Regarding the compatibility with EMC 99/336/EEC (Electro Magnetic Compatibility) and because of the thyristor control mode selected (phase-angle that it is not CE marked by the manufacturer: WATLOW USA) the compliance with EMC directive can not be initially guaranteed. In this sense several precautions will be introduced to minimise the EM effects as: to install EMC filters at mains and output for each thyristor module and to shield and ground the resistors power cables from power connection boxes up to the heater body. Additionally, pre-compliance EMI measurements will be done by AITEMIN during functional test, prior to delivery.

The full EMC compliance measurements will be carried out by SKB at Äspö laboratory after delivery.

d) Functional tests

Complete functional tests will be carried out by AITEMIN after assembling the heating units, prior to delivery.

9 COSTS

The estimated cost for the construction of the complete heating system, in case that this is ordered to AITEMIN, would be the following:

Concept	Units	Unit cost €	Total Cost €
Heater	2	62,950	125,900
Power regulation system	2	31,676	63,352
Data acquisition and control system	1	66,650	66,650
Packing and transport	1	5,410	5,410
TOTAL			260,512

Annex 1:

Thermo-Mechanical Model



UPM-DMAMI

ABAQUS VERSION 6.2-1

THERMO-DISPLACEMENT PROCEDURE

DATE 25-SEPT-2002

CANISTER PROPERTIES

(International System of units)

- Conductivity 60 W/m°C
- Density 7850 Kg/m³
- Young's Modulus 2.1e11 pa
- Poisson's Ratio 0.29
- Expansion Coeff alpha 1e-5
- Specific Heat 403 J/Kg°C

APPLIED TEMPERATURES

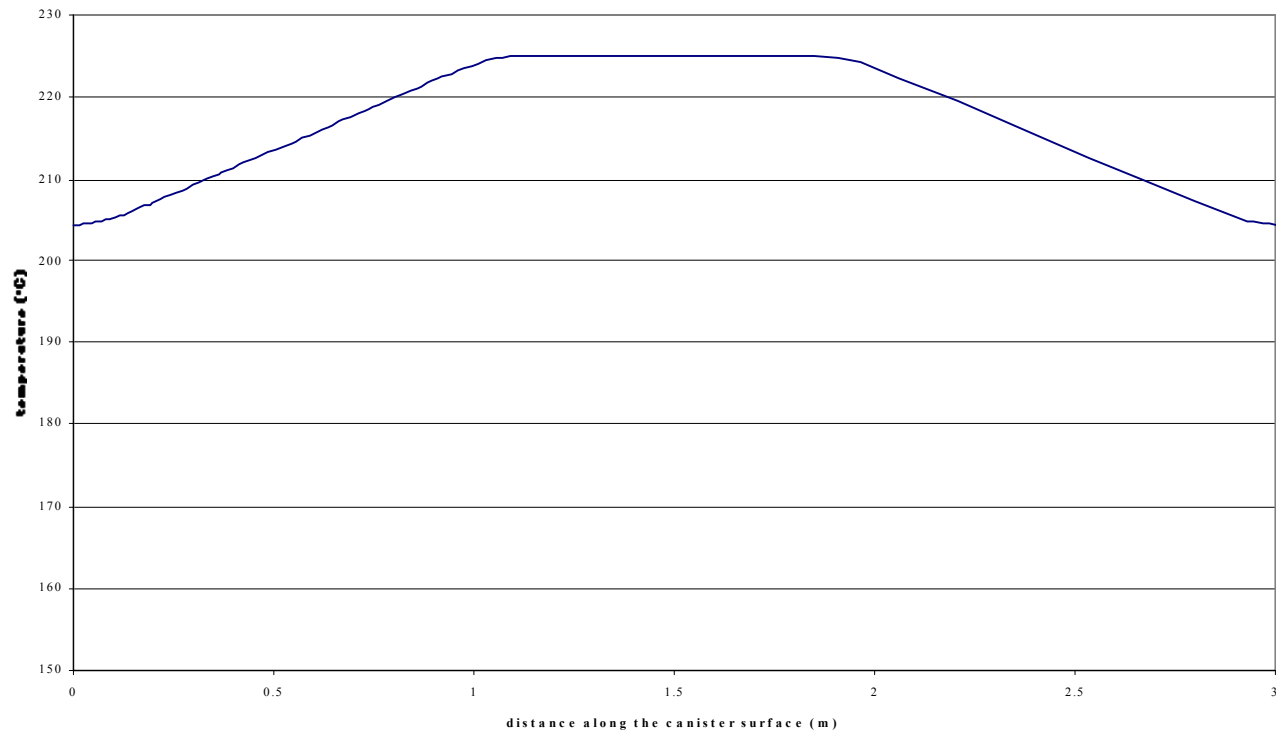

GRID SIZE

- NUMBER OF ELEMENTS IS 15260
- NUMBER OF NODES IS 16293
- NUMBER OF NODES DEFINED BY THE USER 16293
- TOTAL NUMBER OF VARIABLES IN THE MODEL 48879
(DEGREES OF FREEDOM PLUS ANY LAGRANGE MULTIPLIER
VARIABLES)

RESULTS

	Step 2	Step 3
MAXIMUM VALUES		
S11 (pa)	1.51E+07	6.00E+06
S22 (pa)	1.58E+07	4.15E+07
S33 (pa)	1.16E+07	5.97E+06
U (m)	6.56E-03	6.98E-03
U1 (m)	7.89E-04	7.09E-04
U2 (m)	6.53E-03	6.98E-03

Step 2: 20 → 225 °C

Step 3: 0.01 → 12 Mpa

S2-Mises

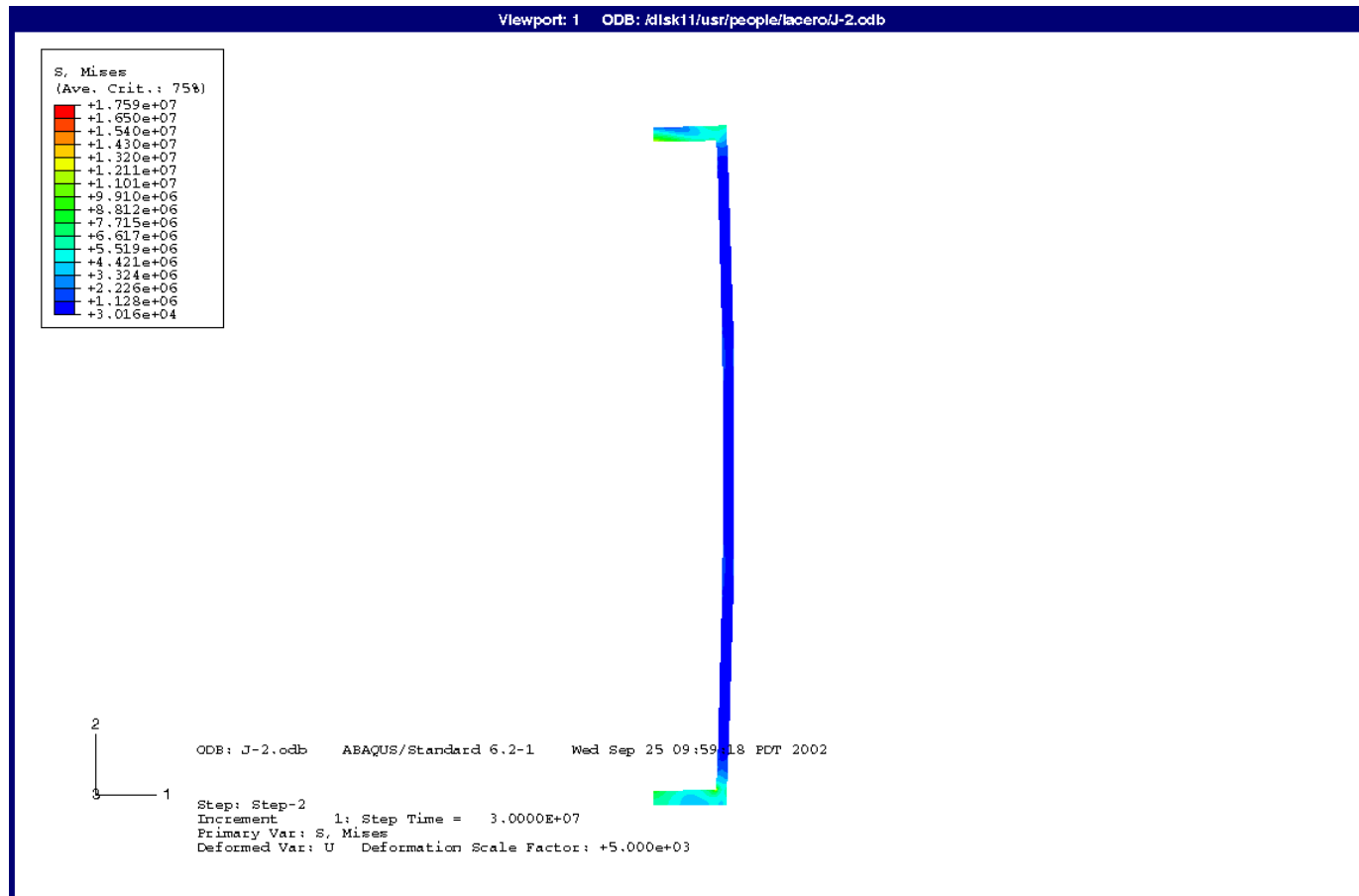

S2-S11

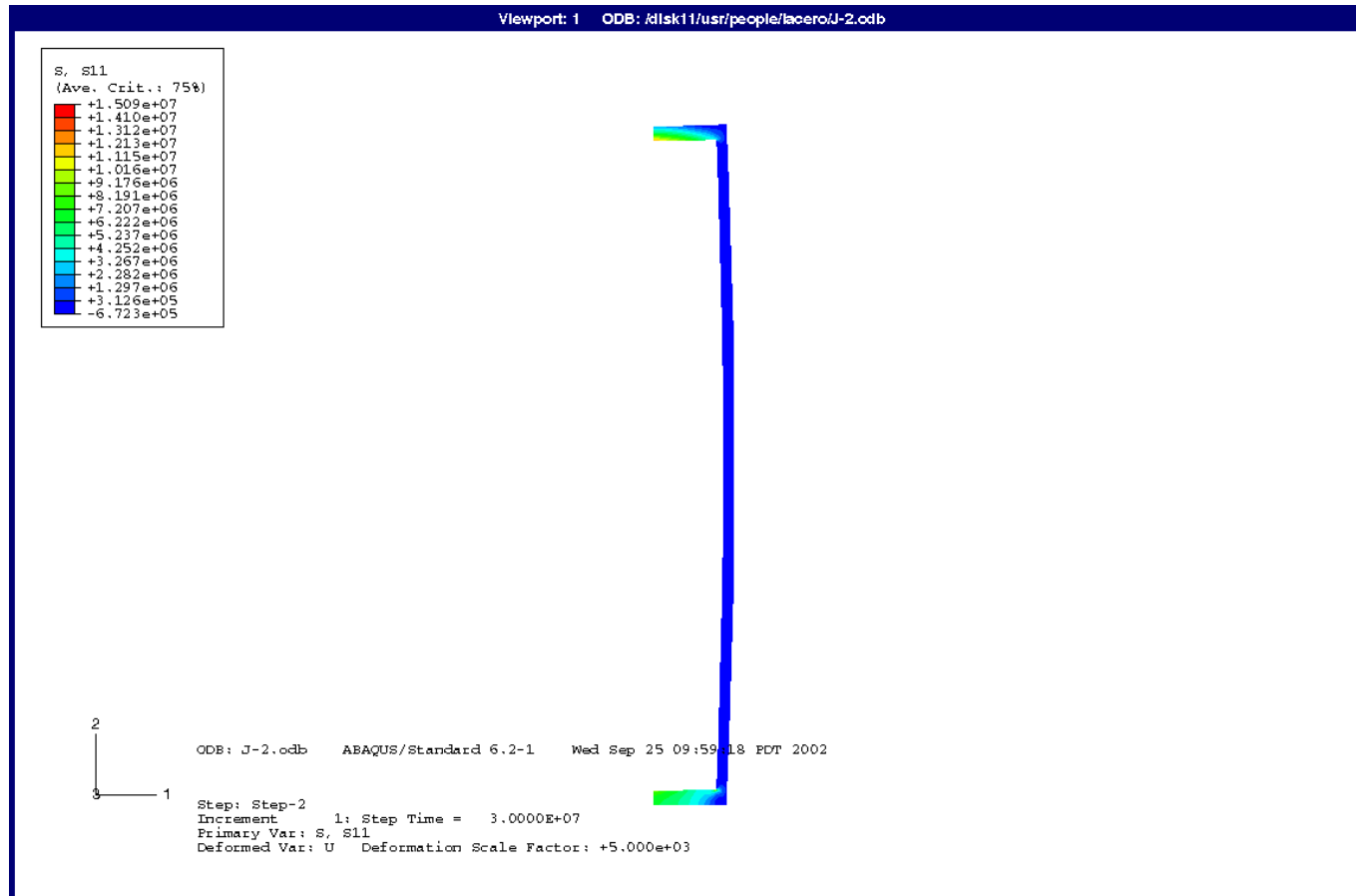

S2-S22

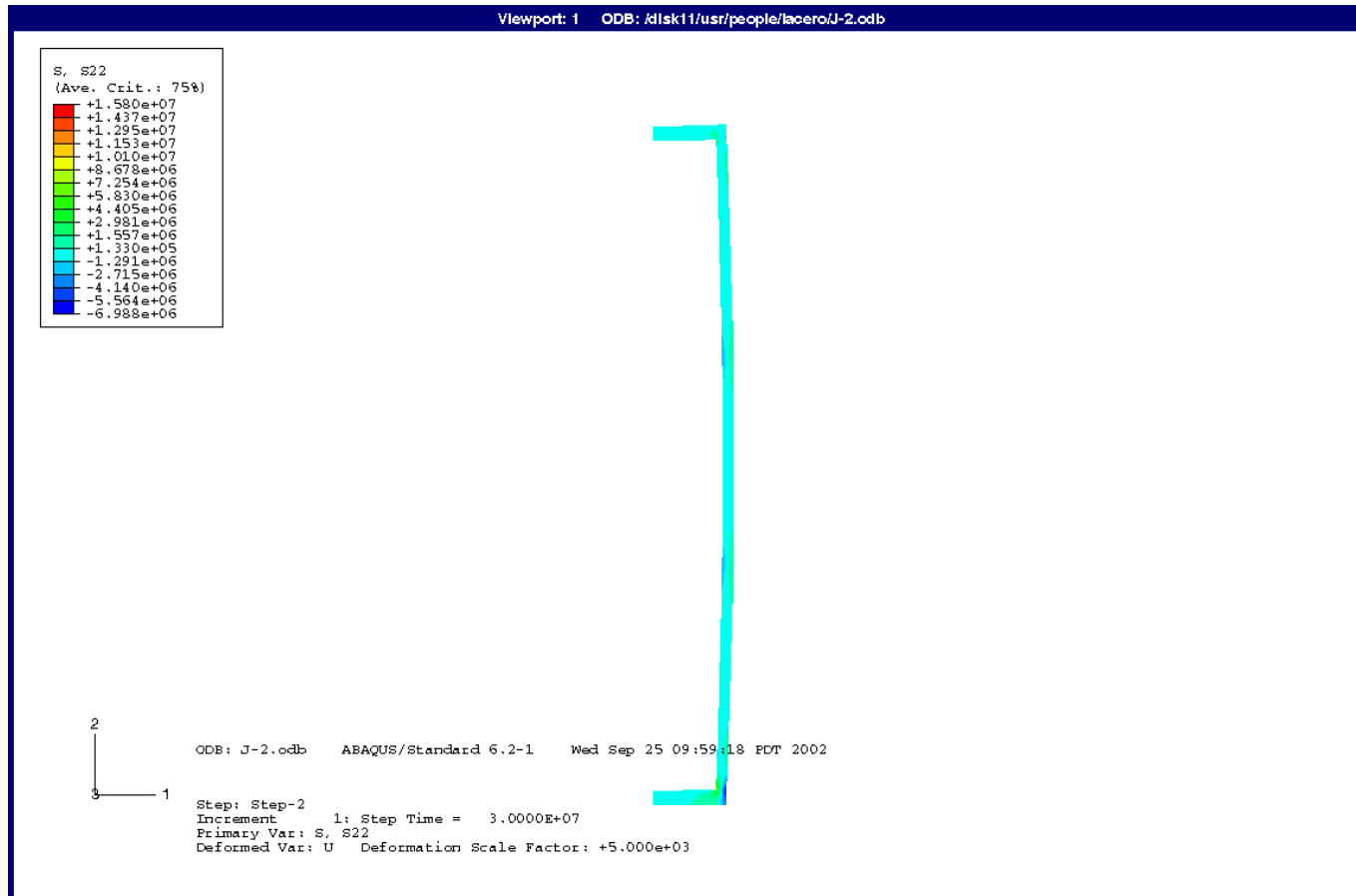

S2-S33

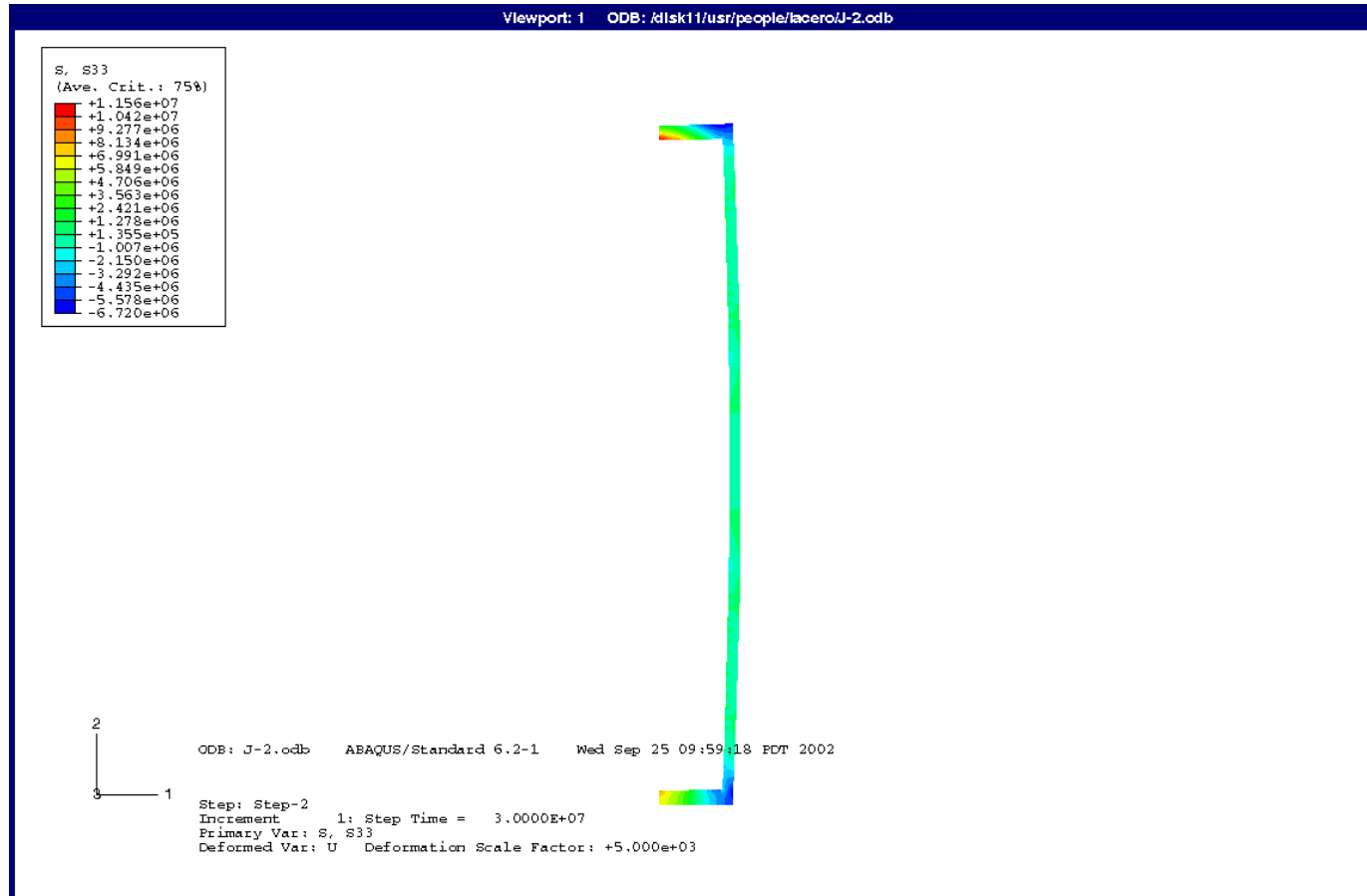

S2-T

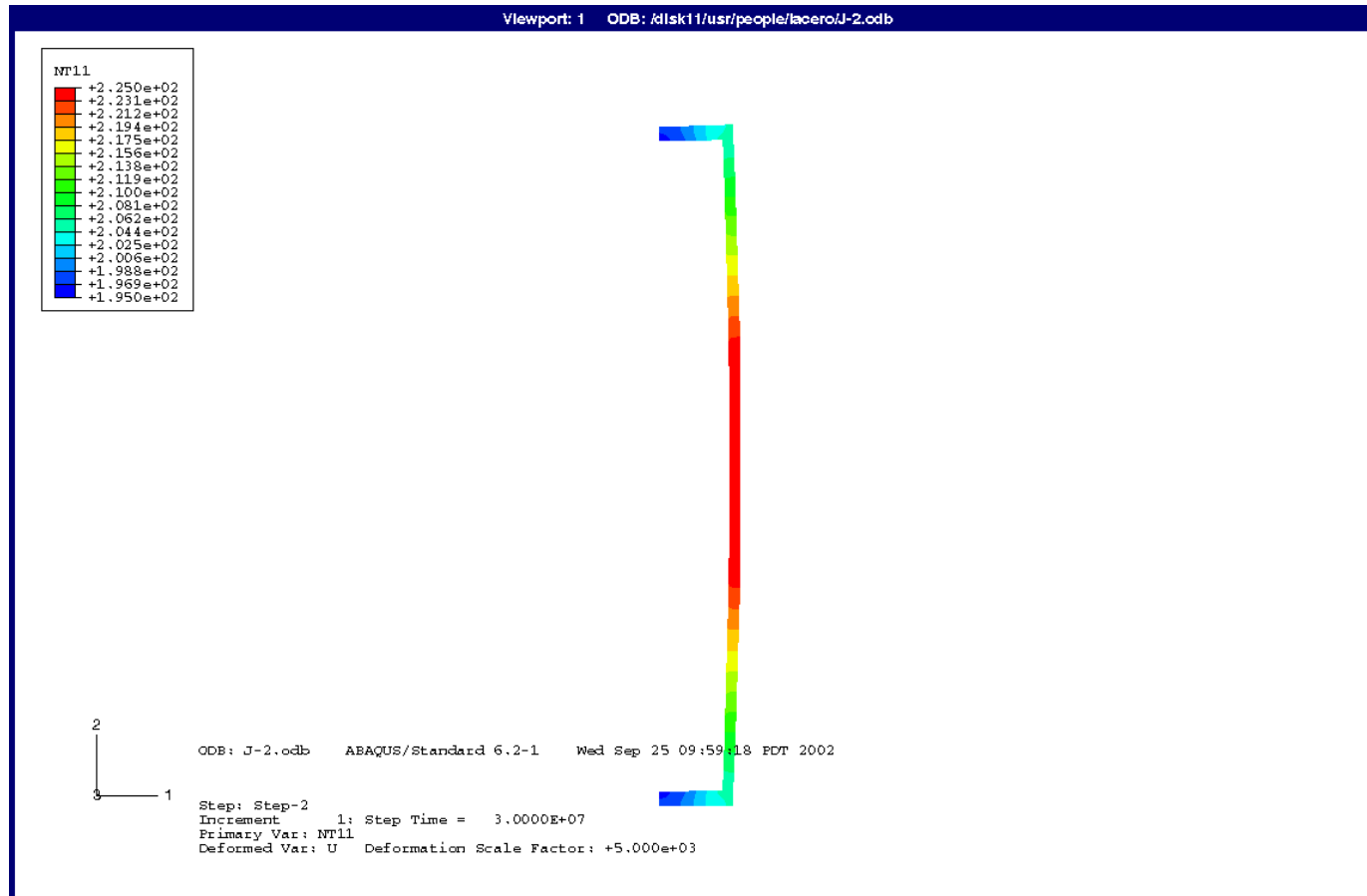

S2-U

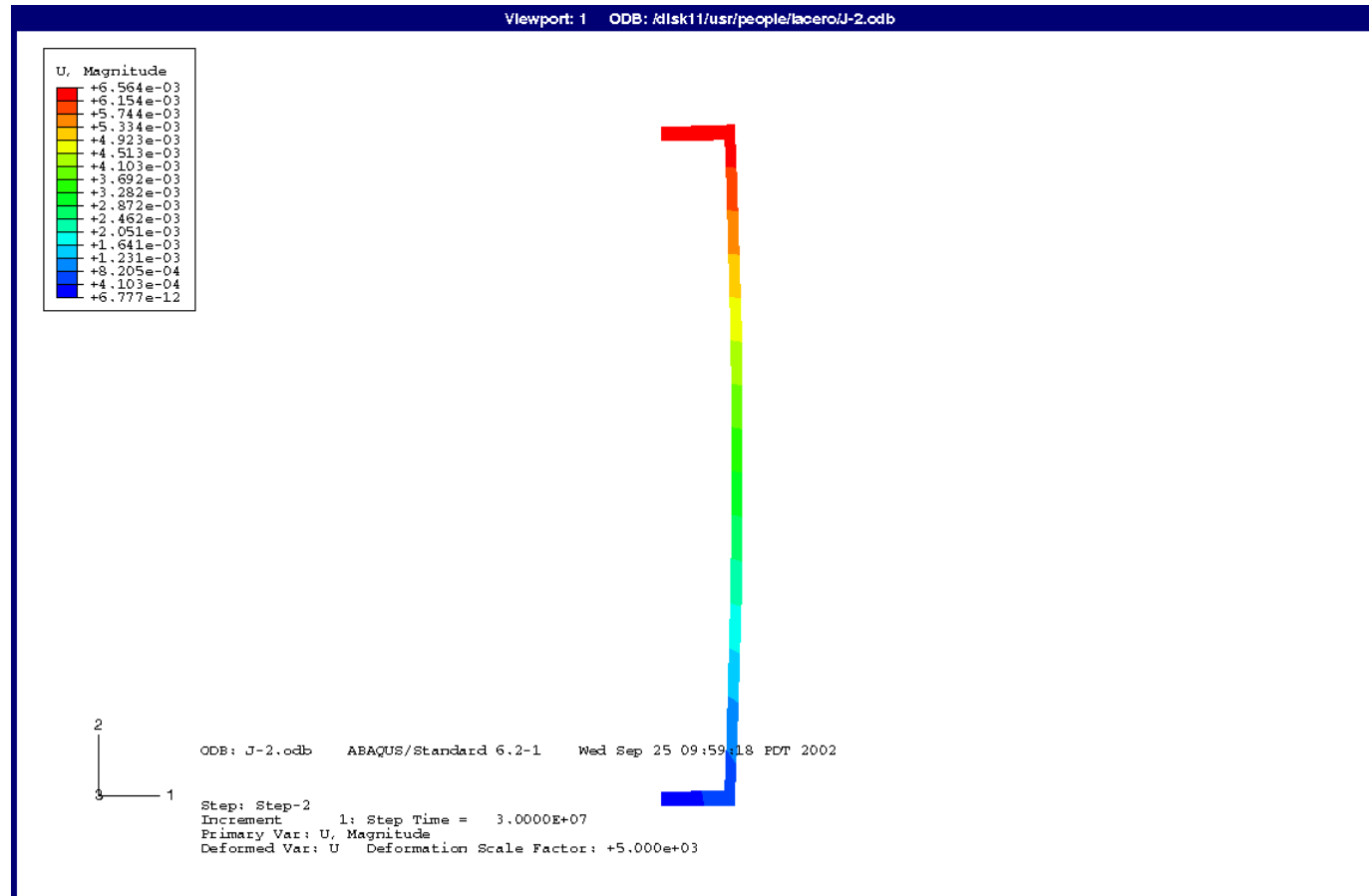

S2-U1

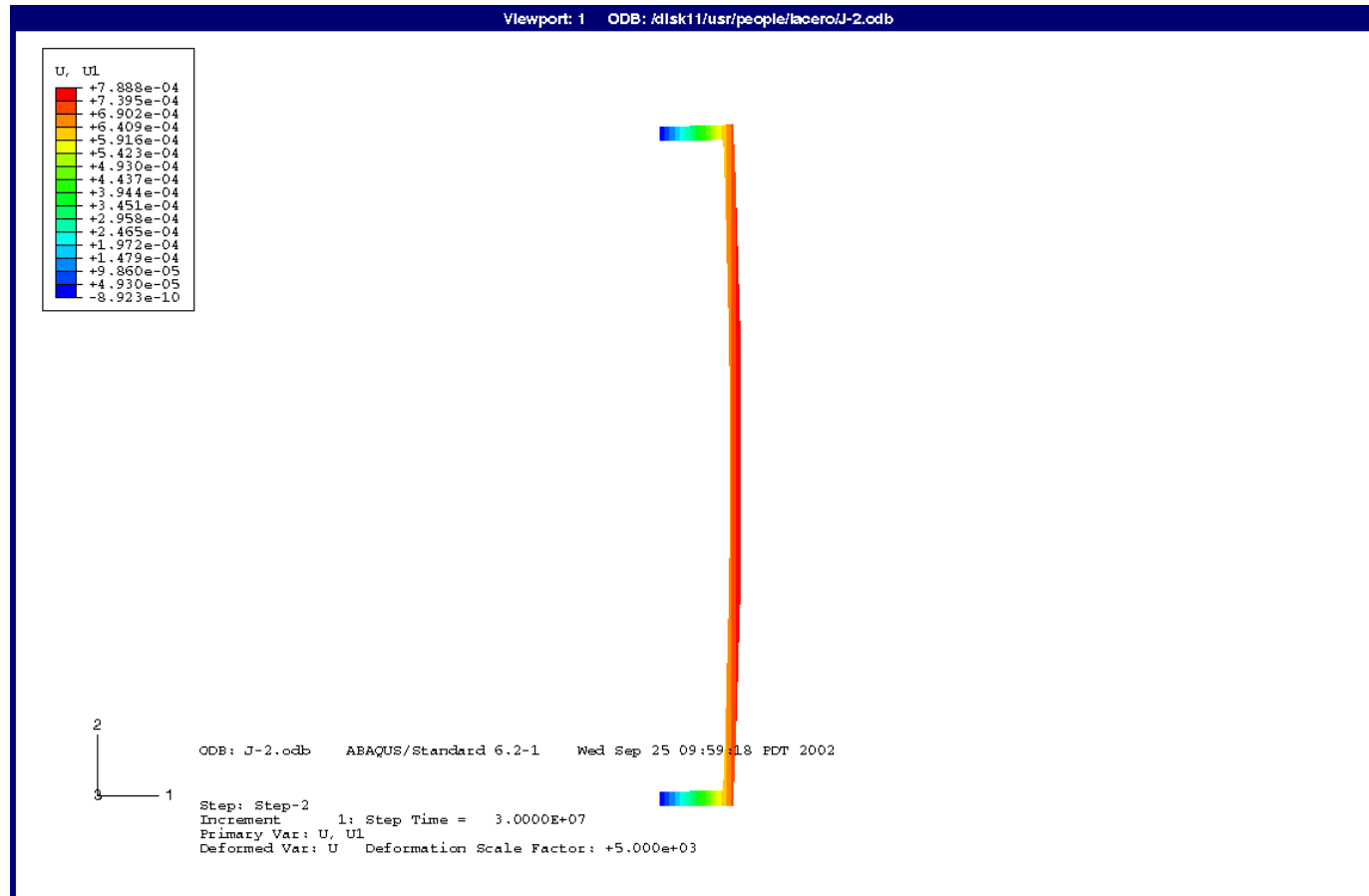

S2-U2

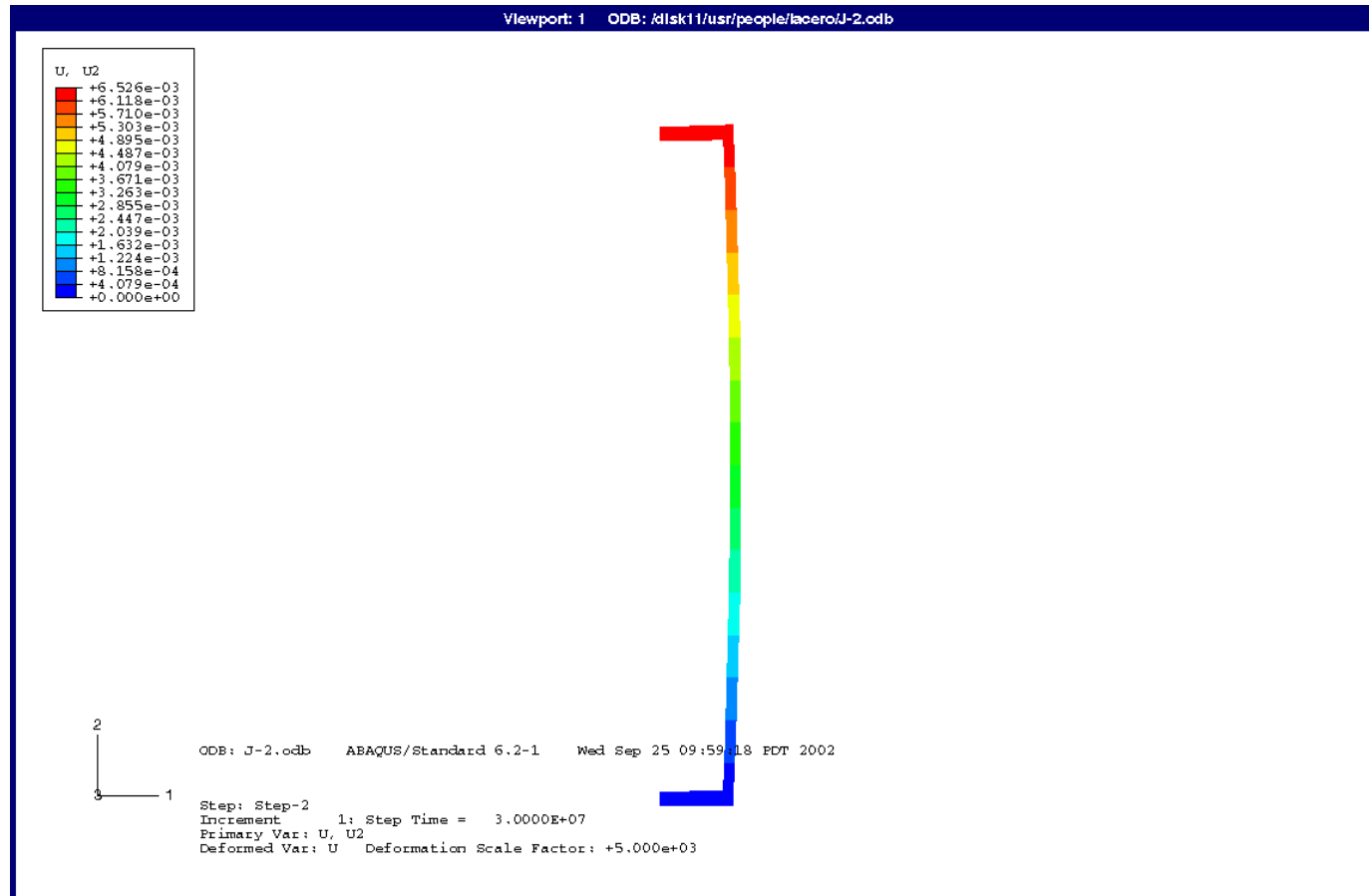

S3-Mises

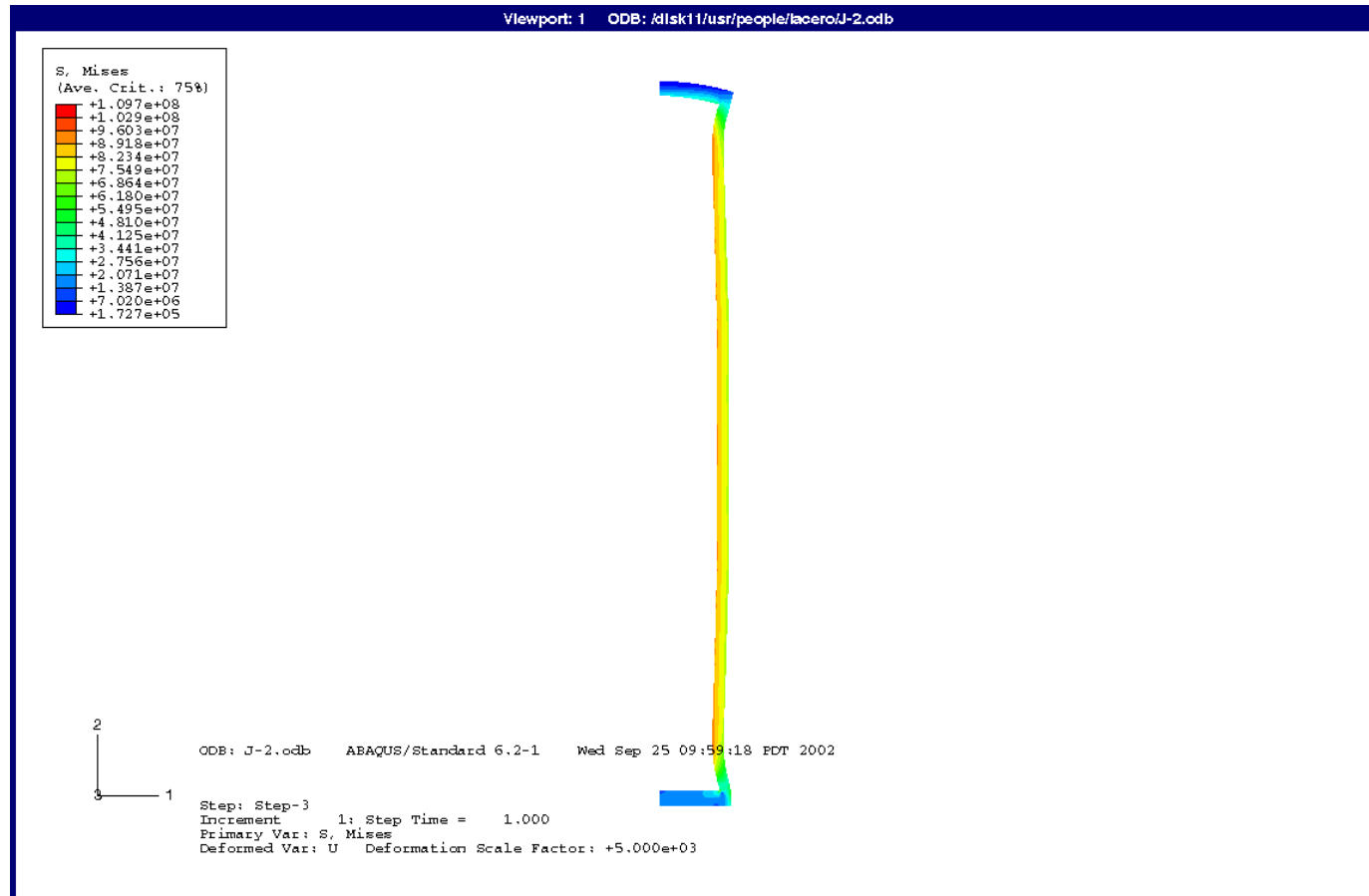

S3-S11



S3-S22

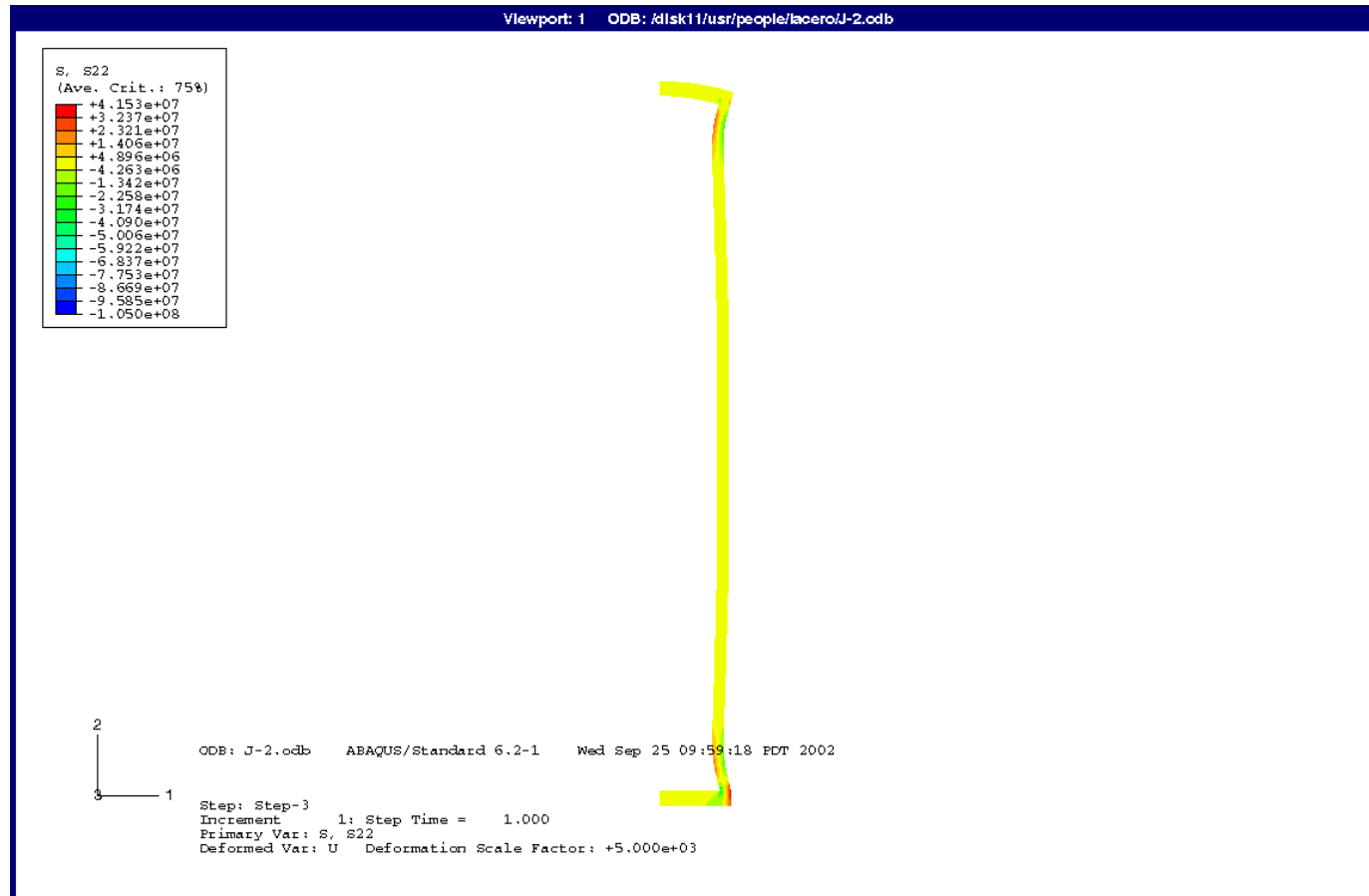

S3-S33

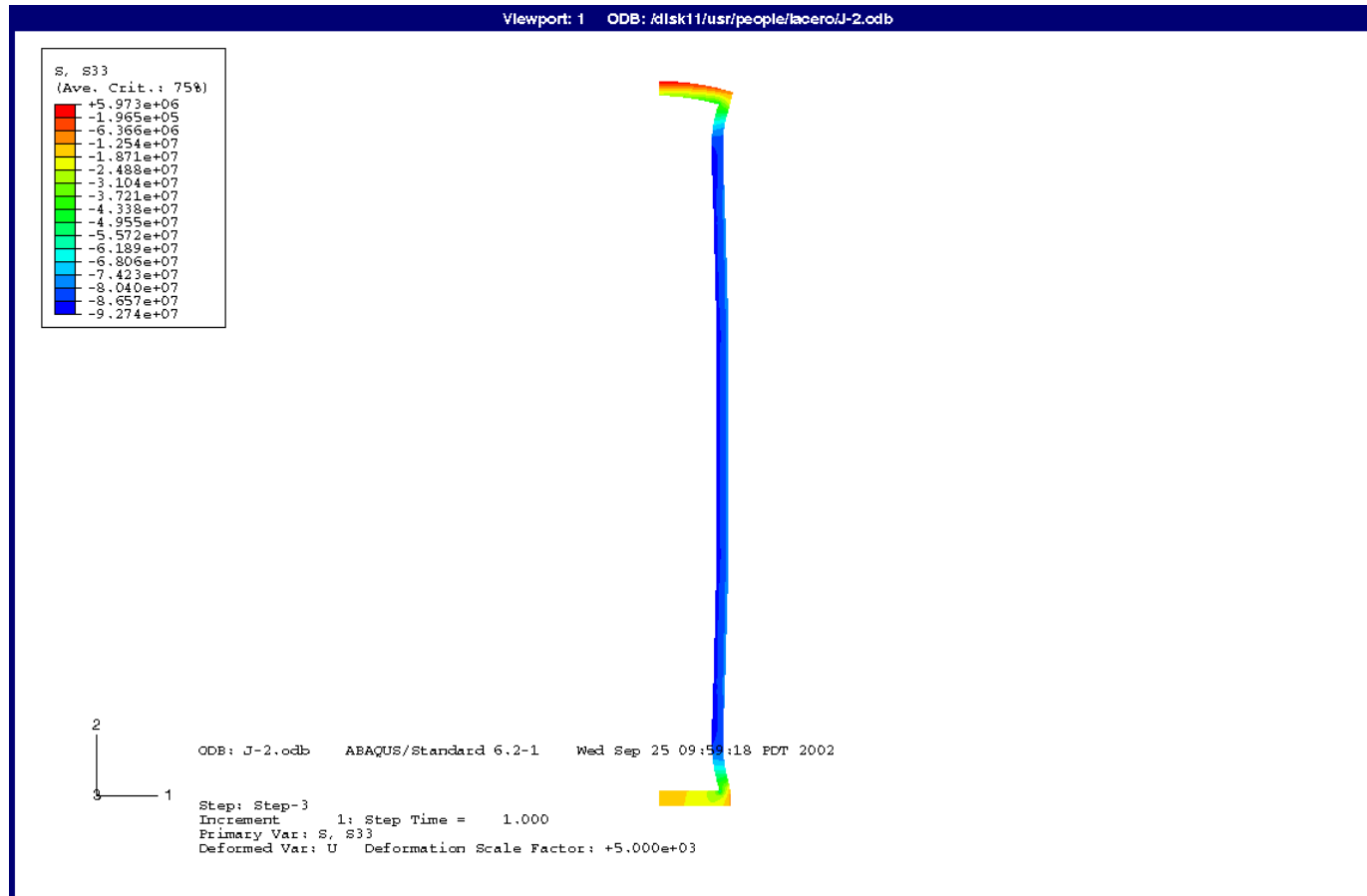

S3-T

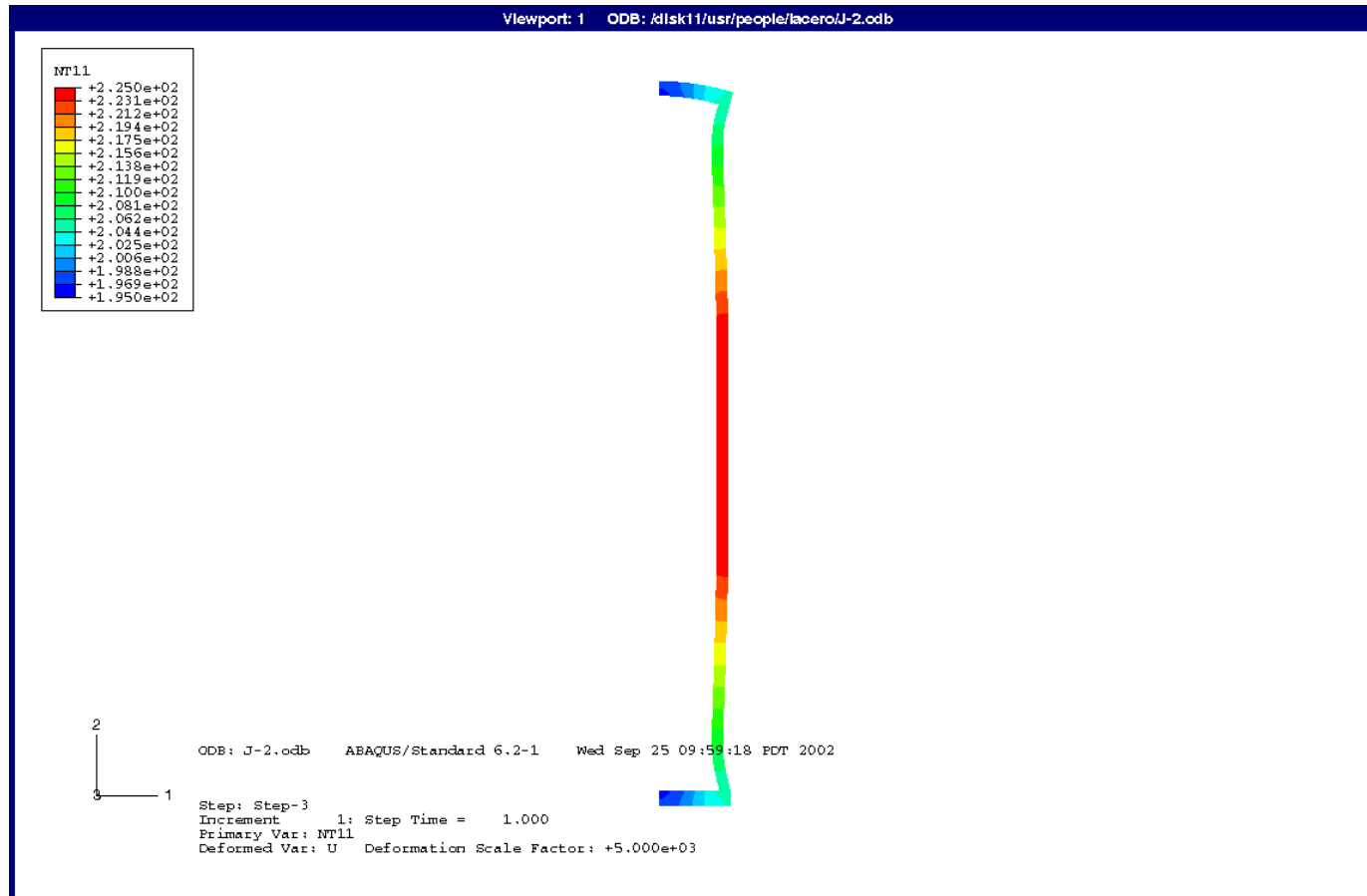

S3-U

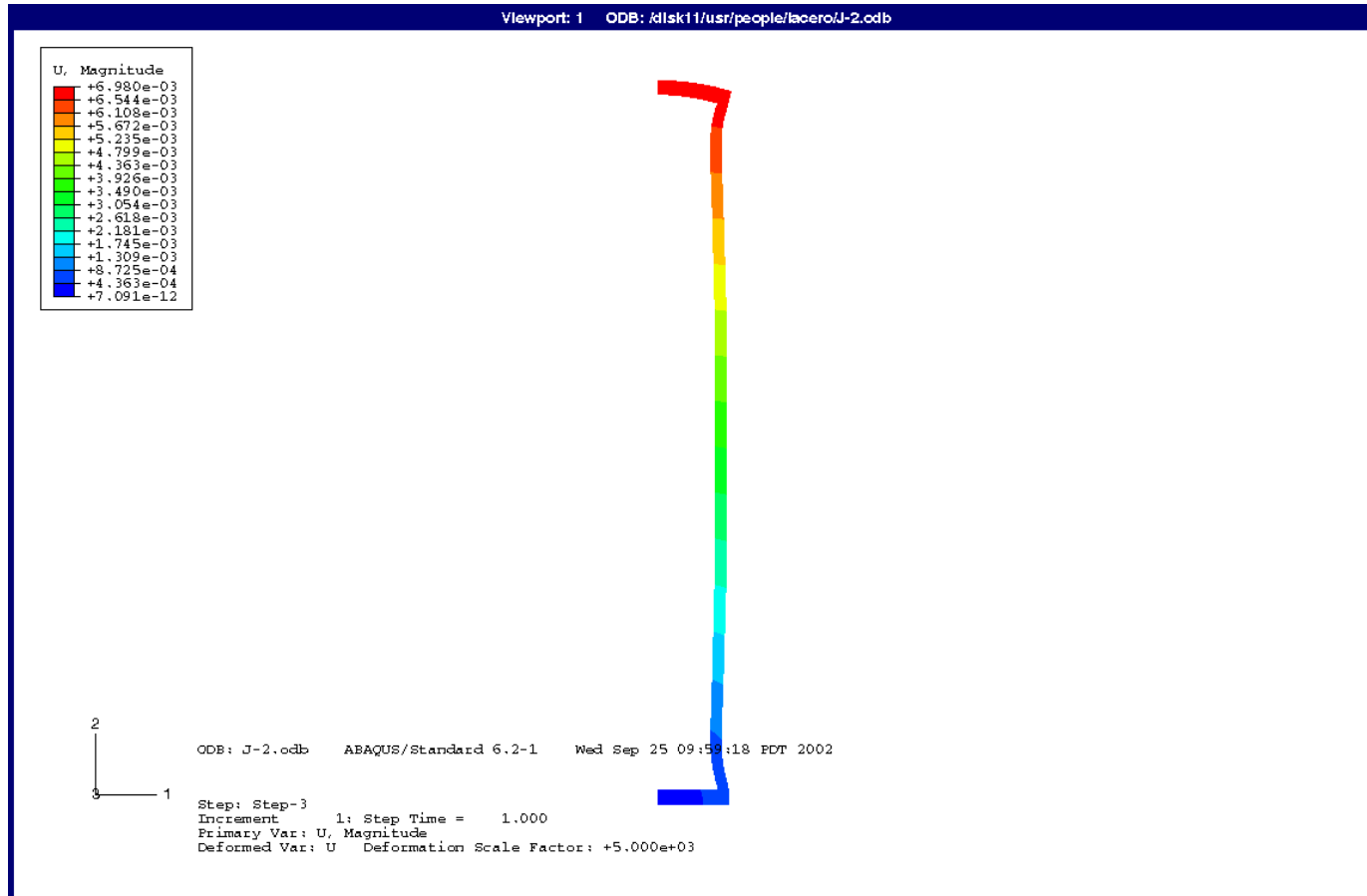

S3-U1

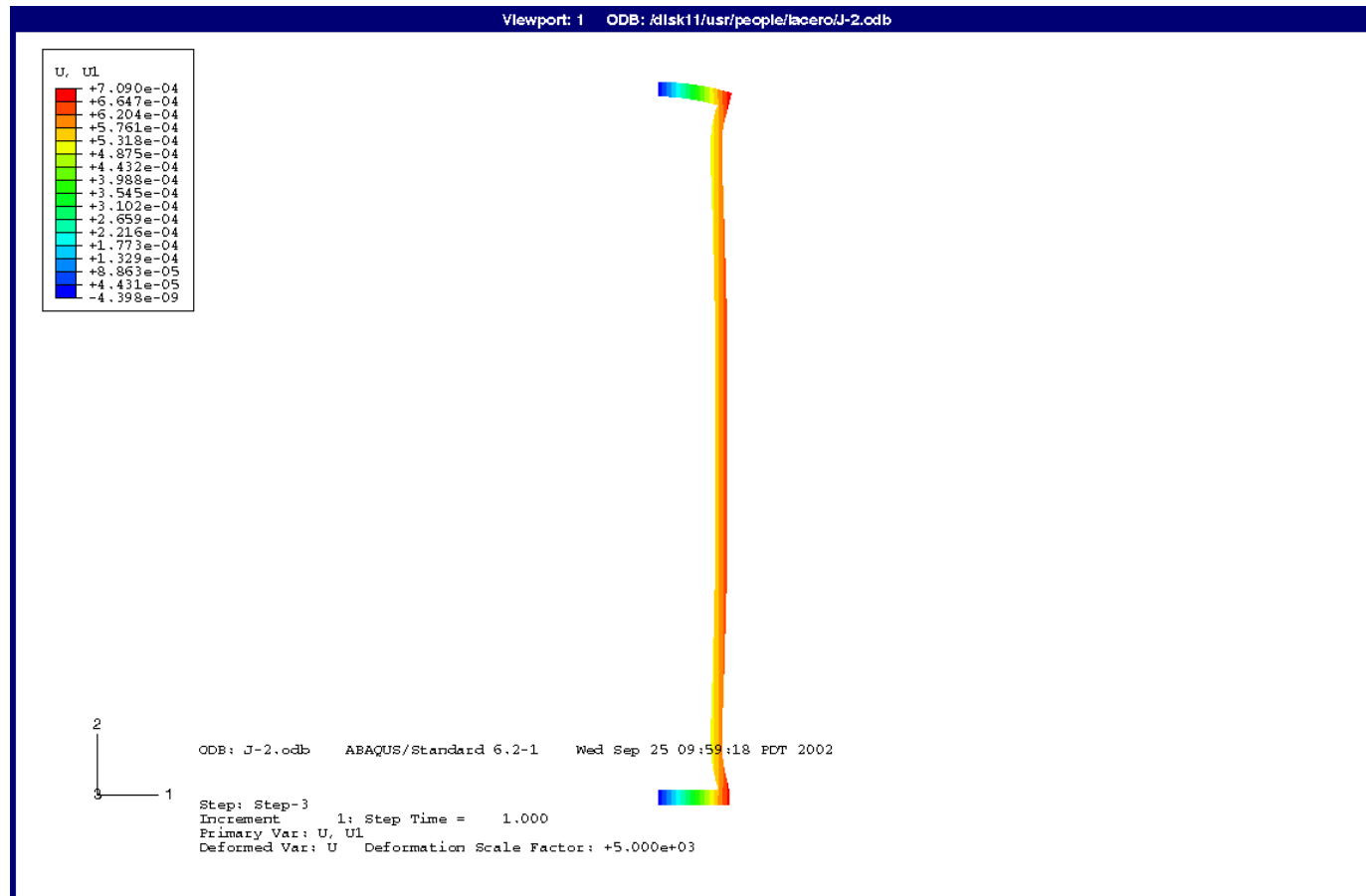

S3-U2

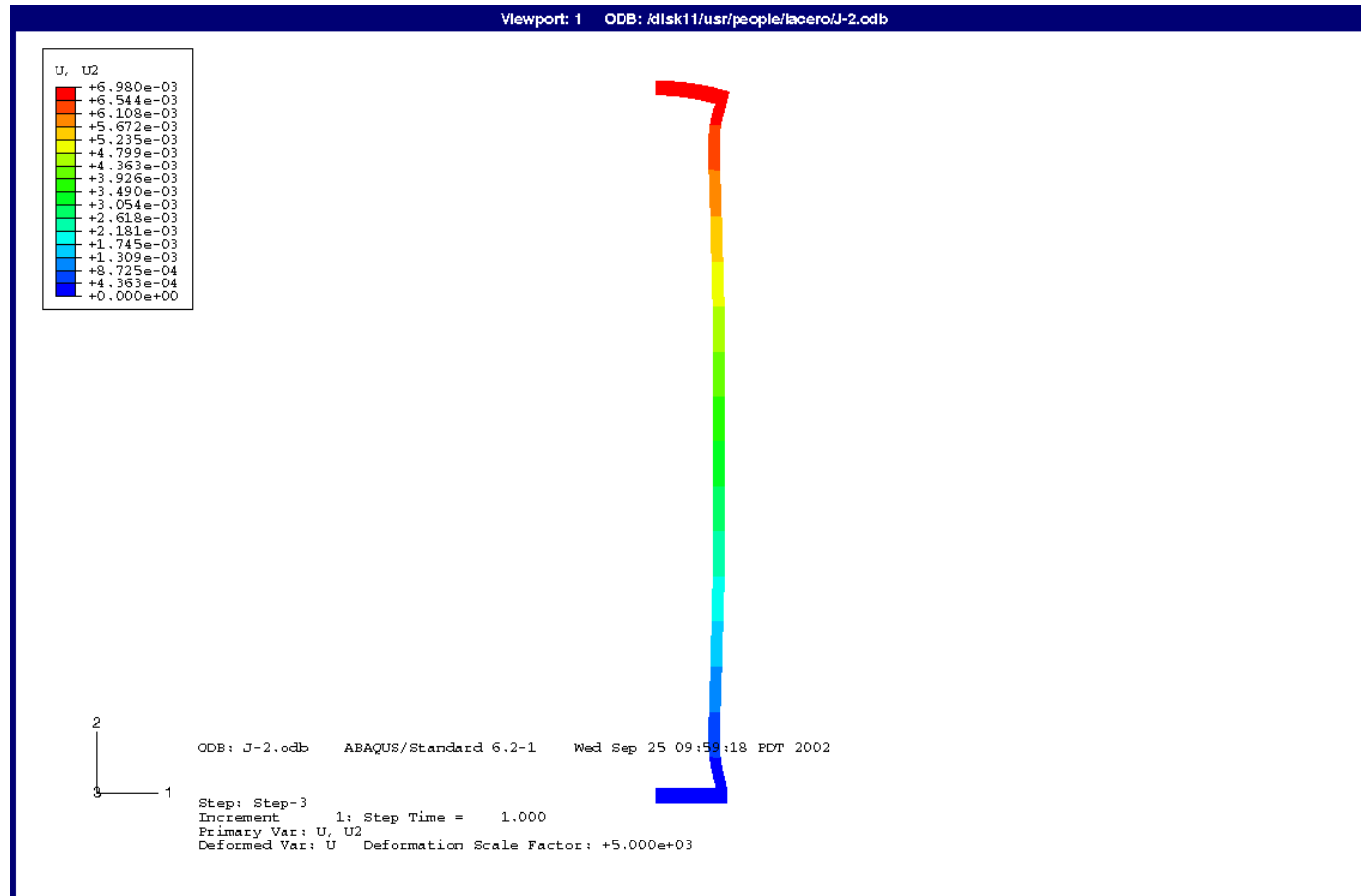

Annex 2:

Drawings

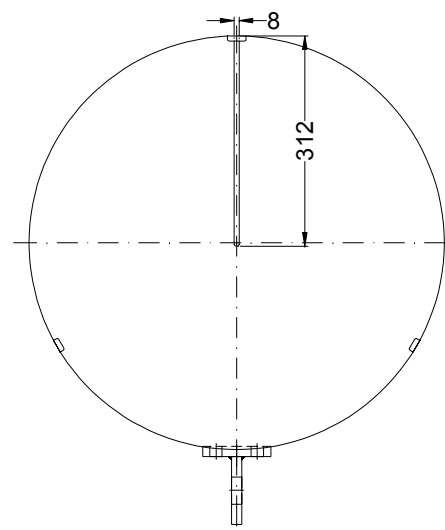
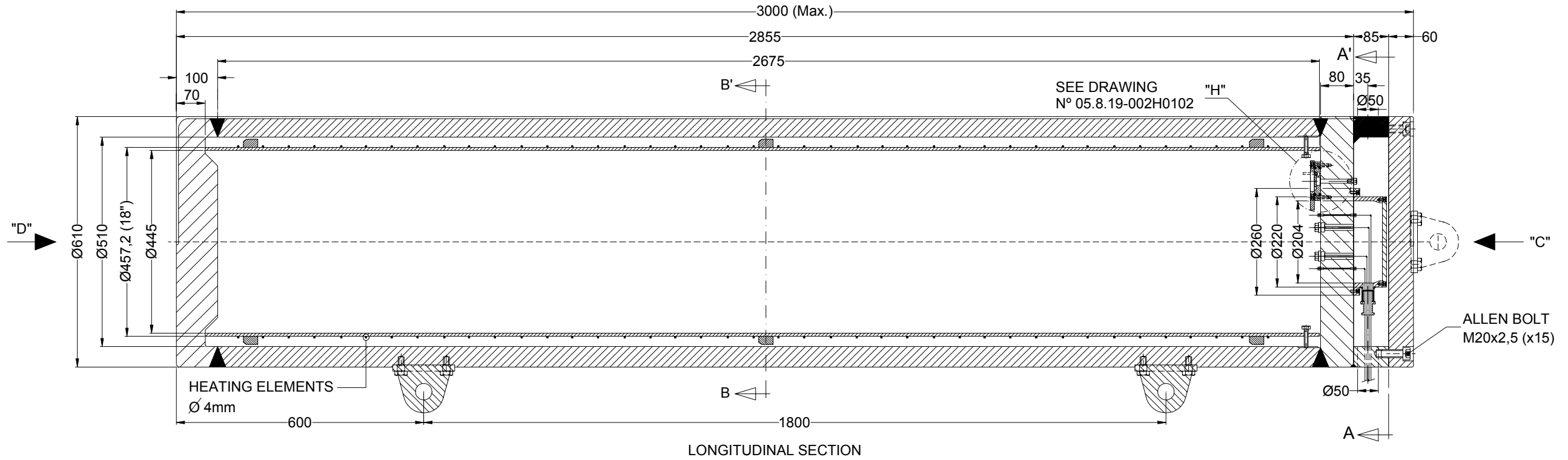

VIEW FROM "D"

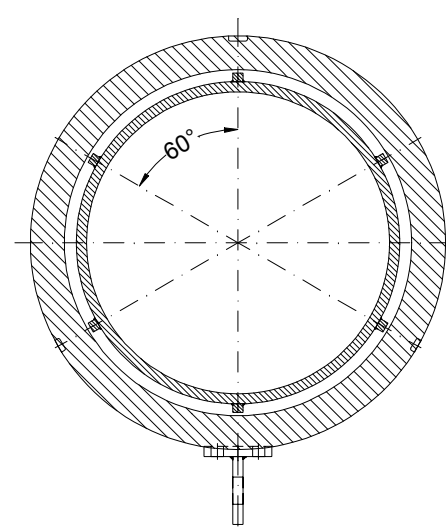

SECTION B-B'

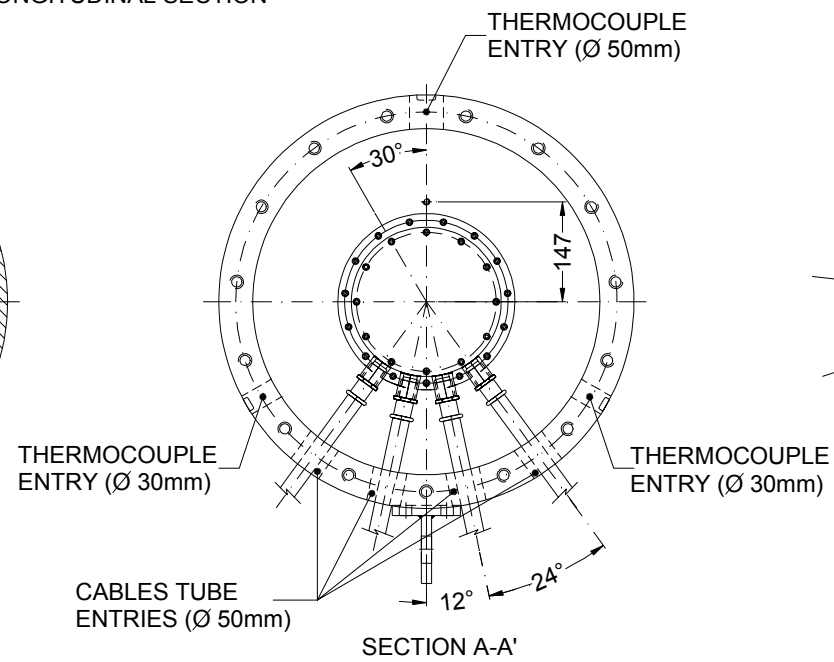

SECTION A-A'

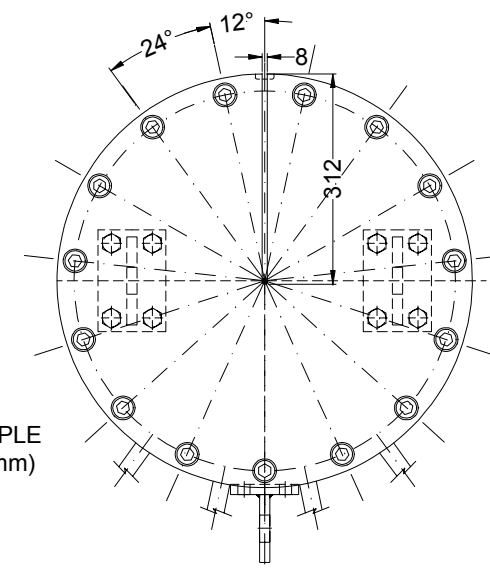

VIEW FROM "C"

	Fecha	Firma	 Aitemin
Diseñado :	02-10-15		
Dibujado :	02-10-19	JMT	
Aprobado :			
Escala 1:10	Proyecto : TBT		No. : 05.8.19-001
Formato A3	HEATER BODY		Revisión : 2 Hoja: 01 de: 06 CD :

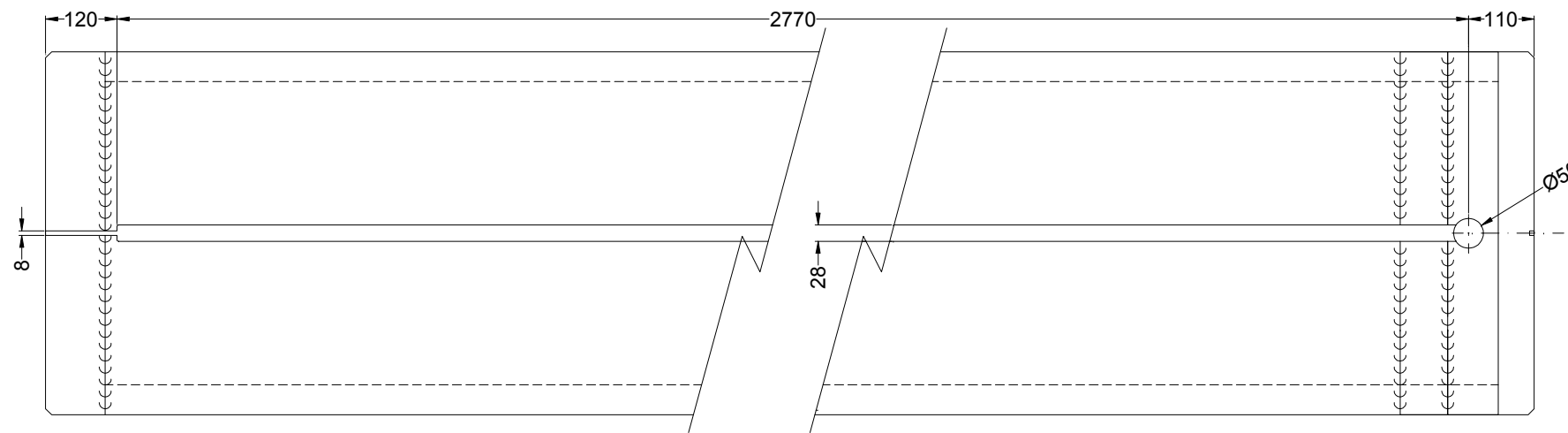

VIEW FROM "A"

BOTTOM

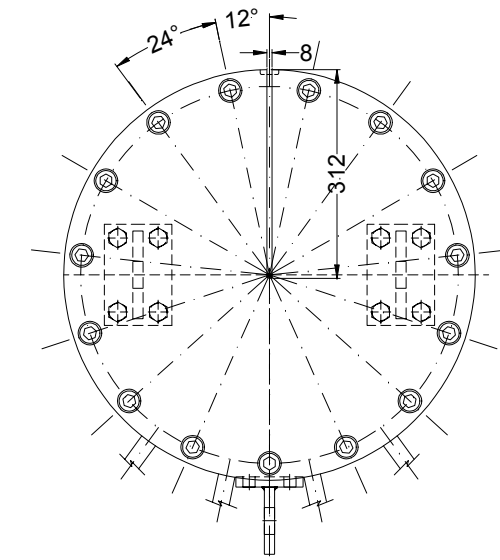

VIEW FROM "E"

TOP

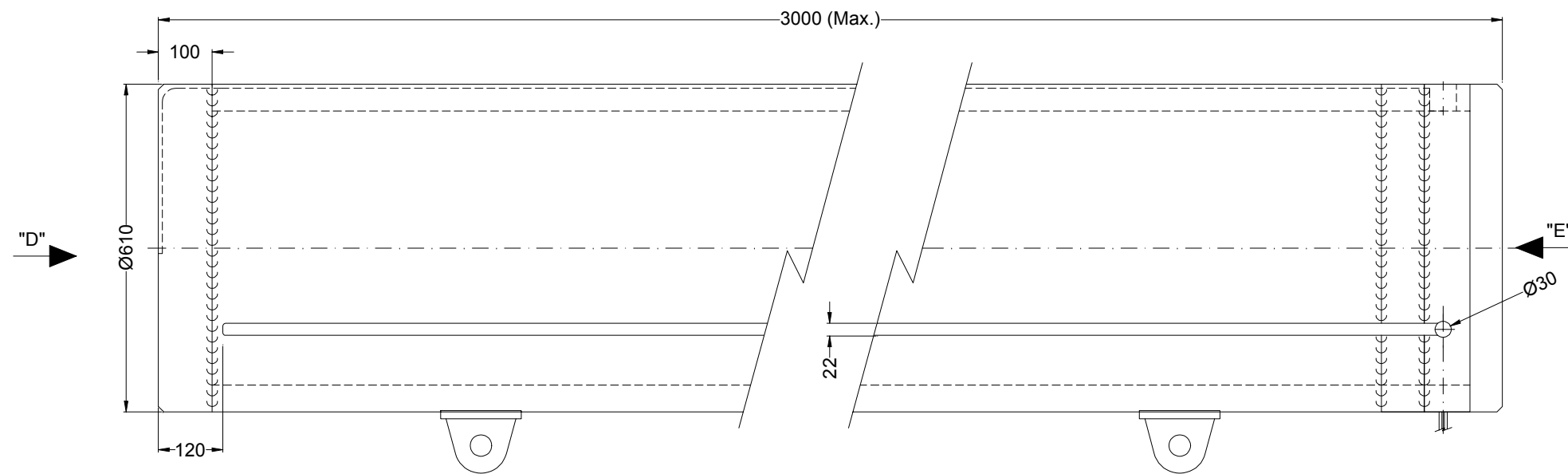

VIEW FROM "B"

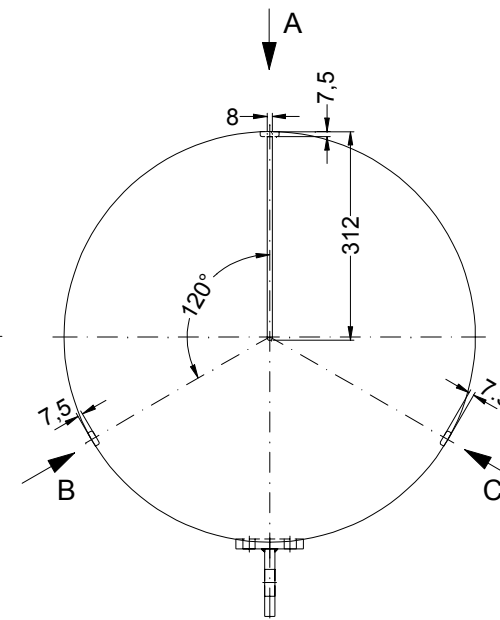

VIEW FROM "D"

VIEW FROM "C" IS SYMMETRICAL TO VIEW FROM "B"

	Fecha	Firma	
Diseñado :	02-10-15		
Dibujado :	02-10-17	JMT	
Aprobado :			
Escala 1:10	Proyecto : TBT		No. : 05.8.19-001
Formato A3	HEATER BODY GROOVES FOR EXTERNAL THERMOCOUPLES		Revisión : 2 Hoja: 02 de: 06 CD :

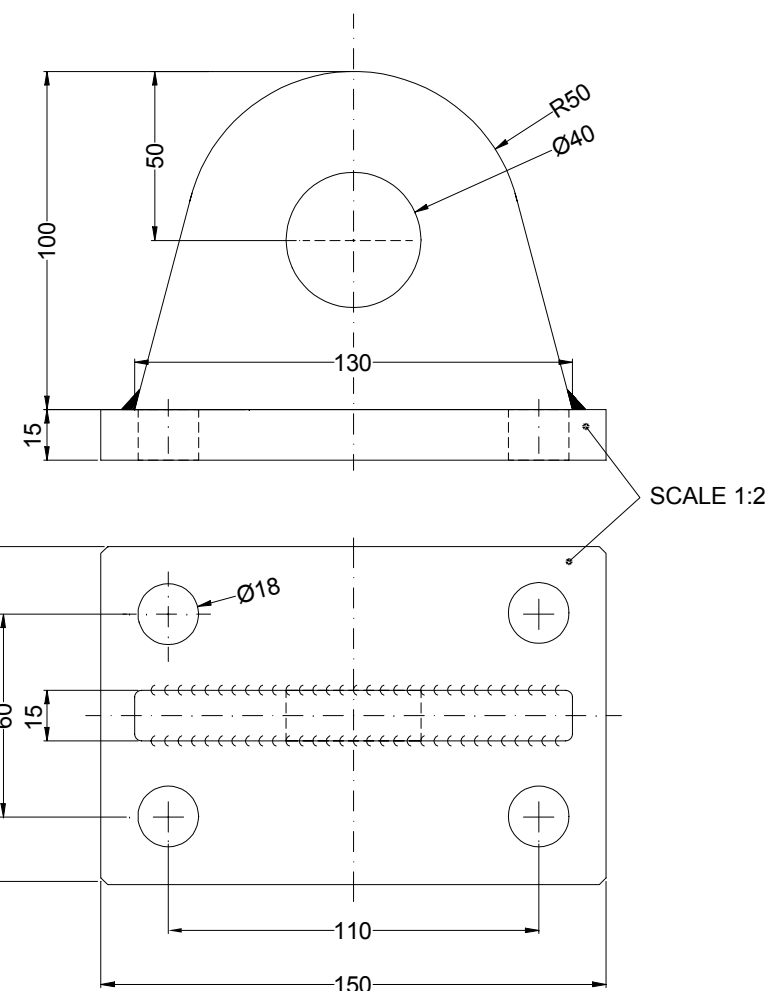
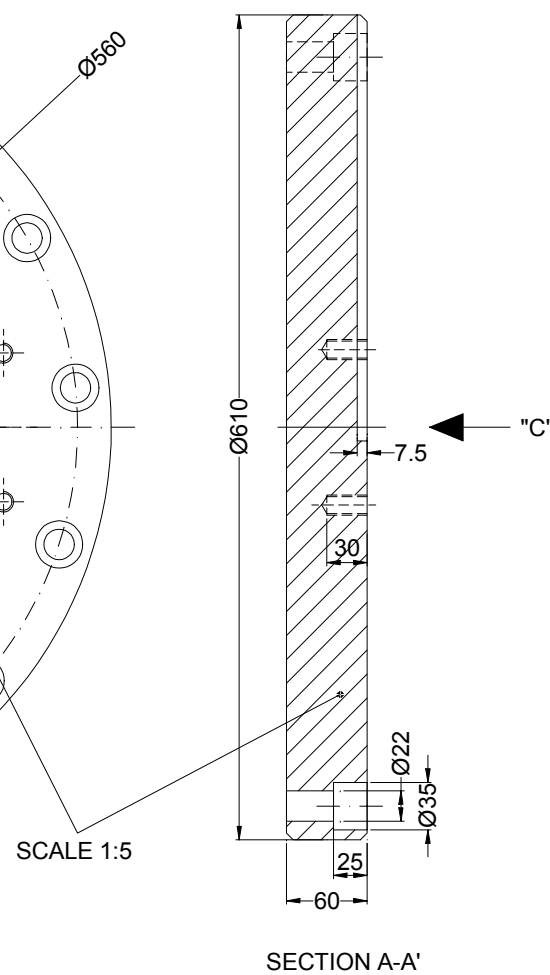
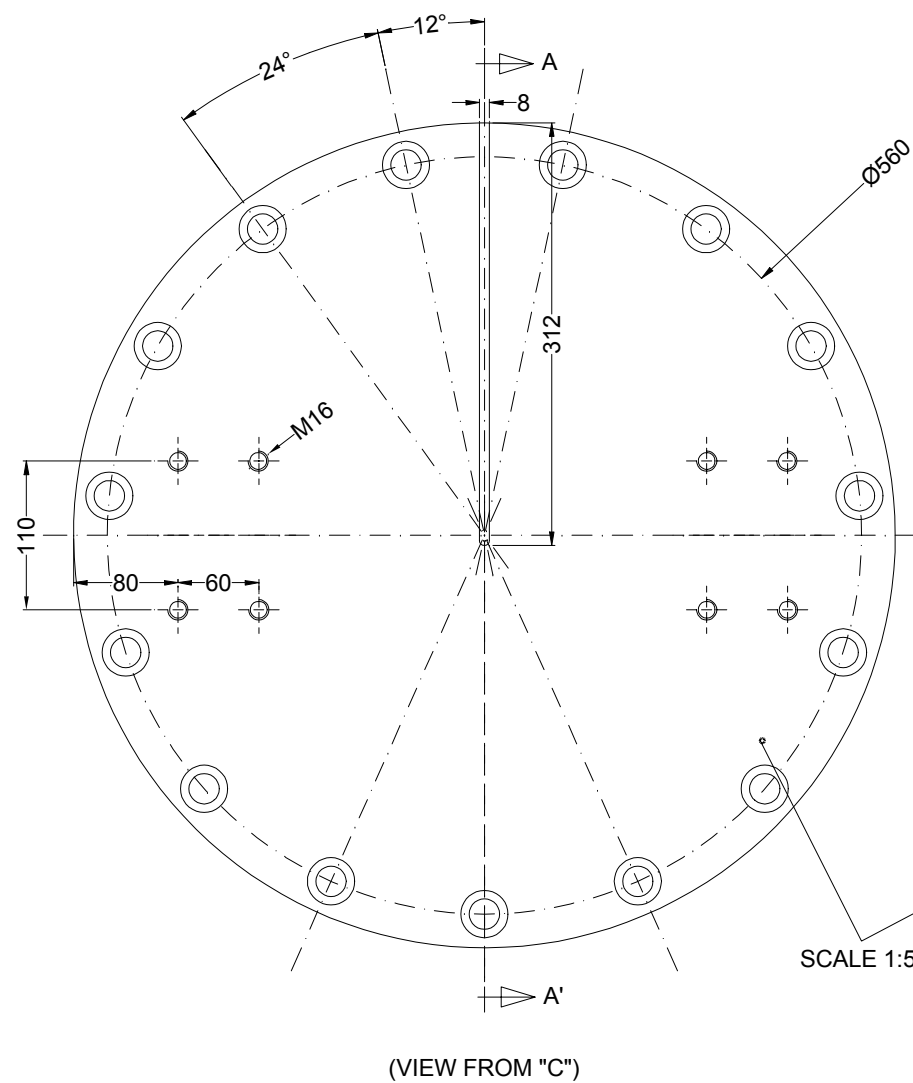

	Fecha	Firma	
Diseñado :	02-09-16		
Dibujado :	02-10-17	JMT	
Aprobado :			
Escala 1:5	Proyecto : TBT		No. : 05.8.19-001
Formato A3	HEATER TOP COVER & HANGER		Revisión : 2
			Hoja: 03 de: 06
			CD :

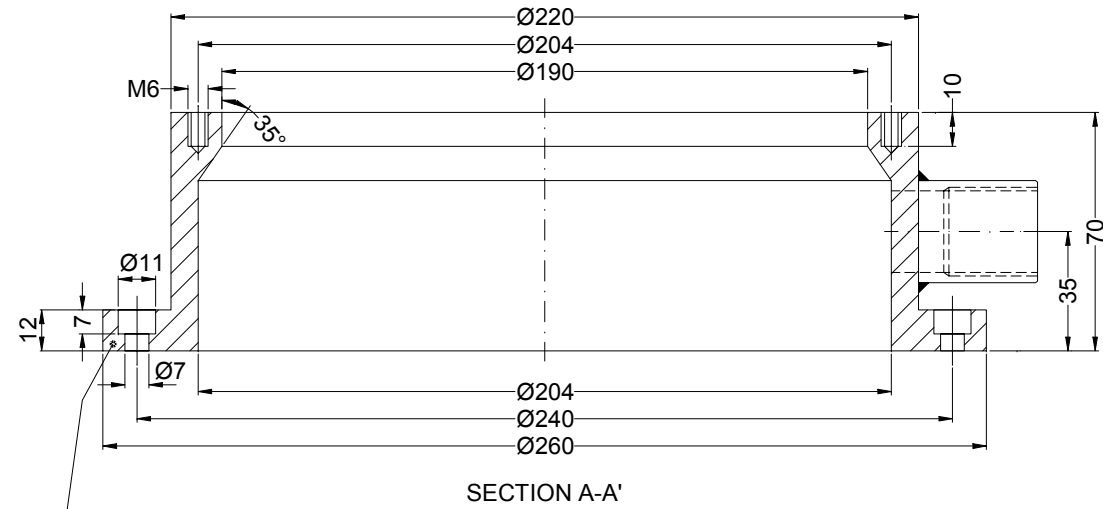

SCALE 1:2

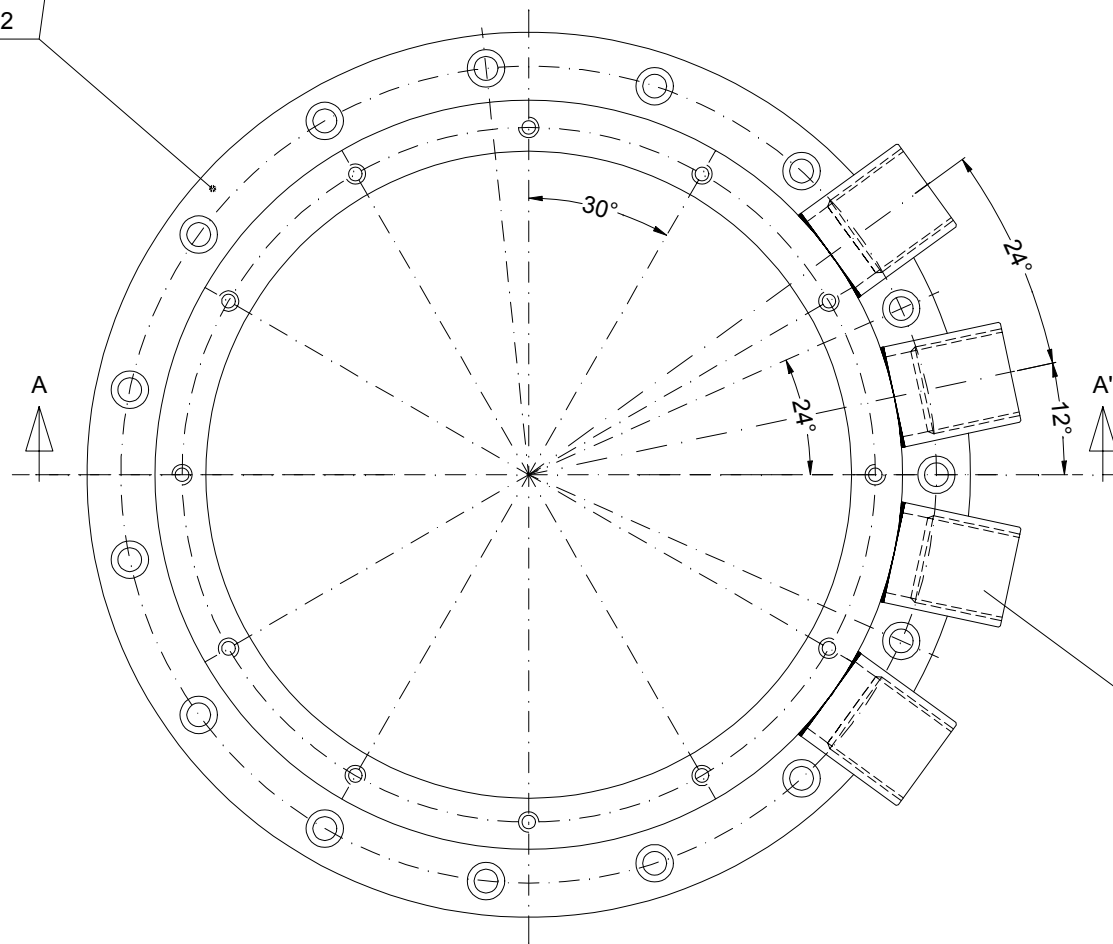

SCALE 1:2

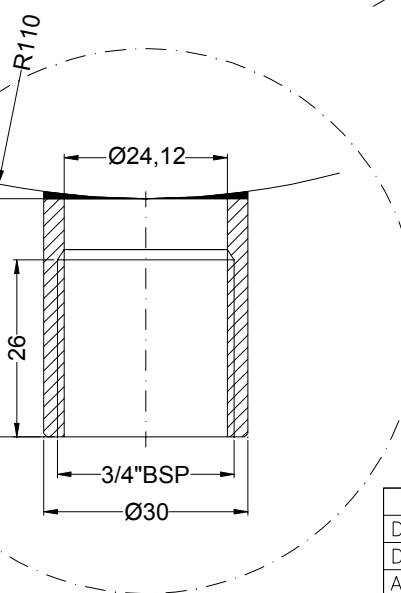
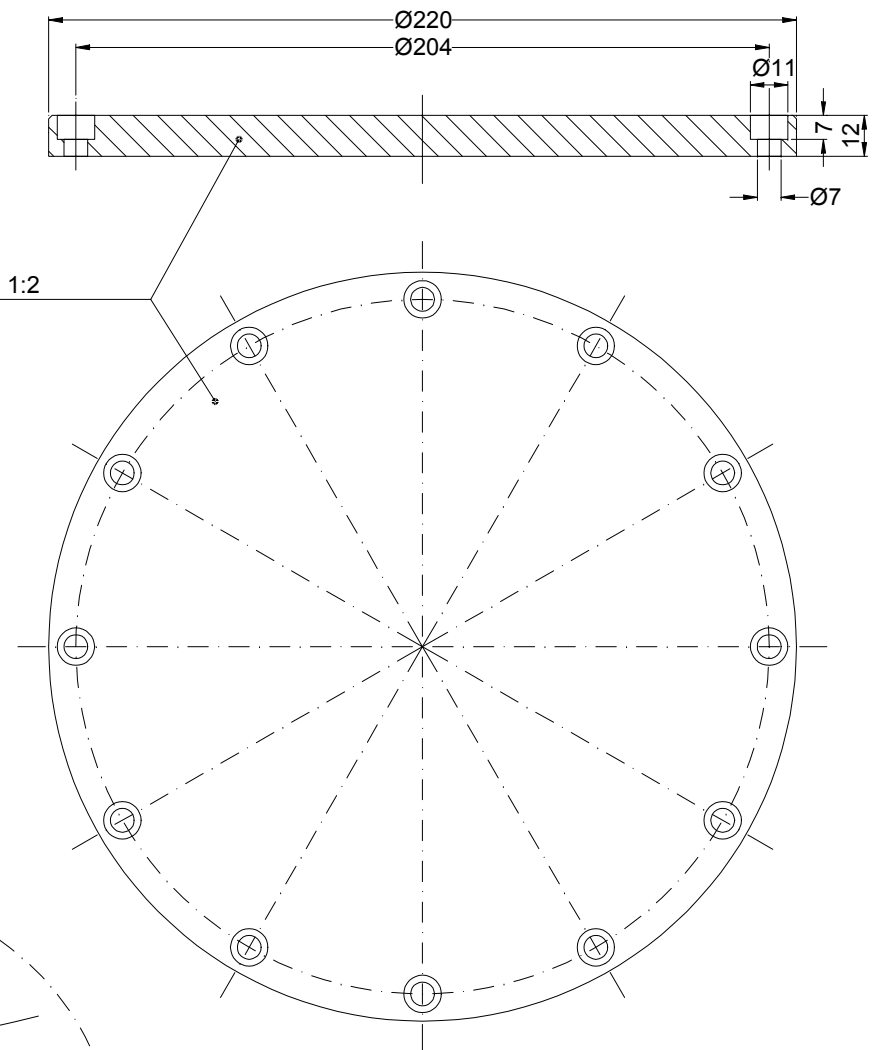

	Fecha	Firma	 Aitemin
Diseñado :	02-09-16		
Dibujado :	02-10-17	JMT	
Aprobado :			
Escala 1:2	Proyecto : TBT		No. : 05.8.19-001
Formato A3	HEATER CABLE BOX		Revisión : 2 Hoja: 04 de: 06 CD :

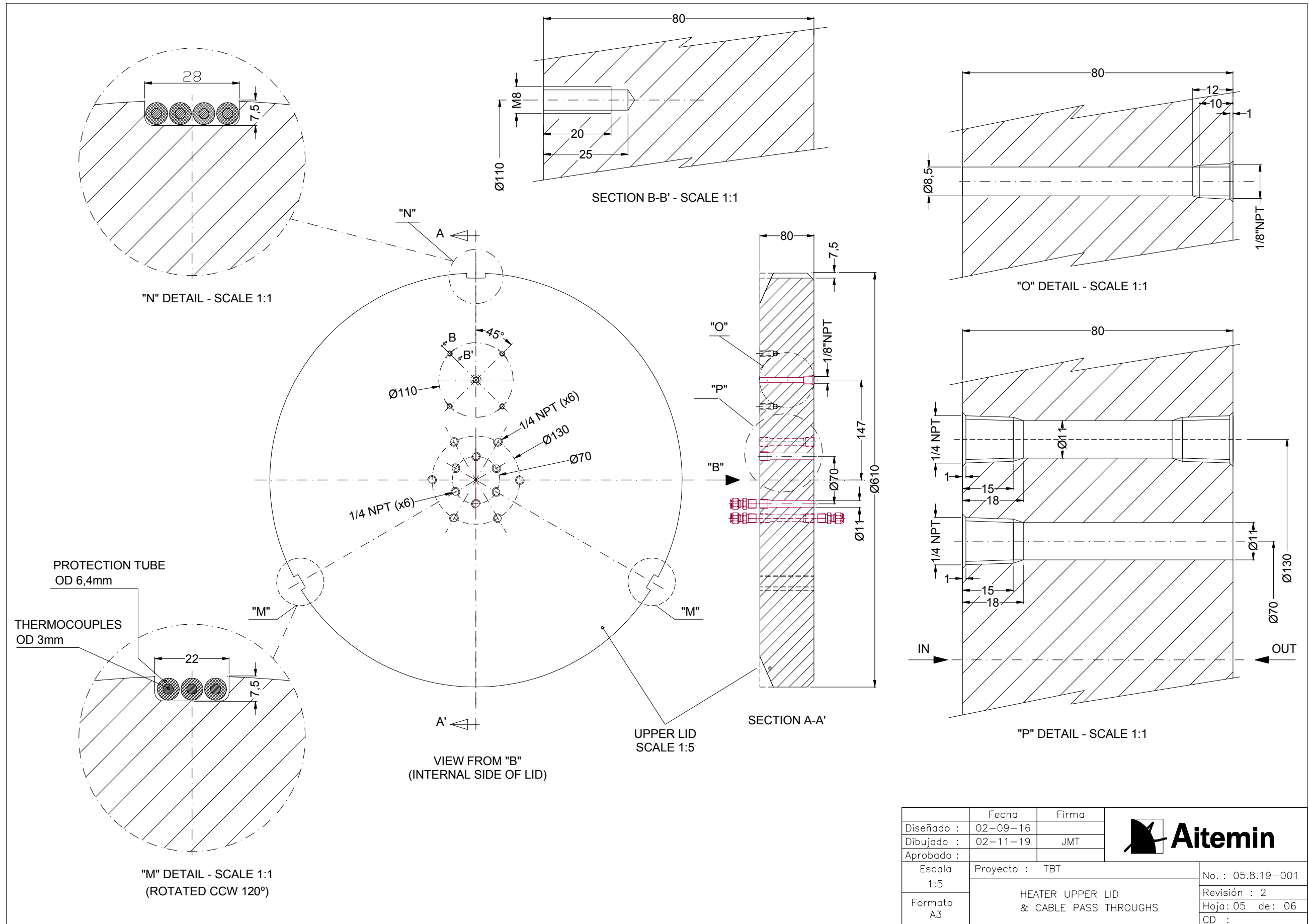

	Fecha	Firma	
Diseñado :	02-09-16		
Dibujado :	02-11-19	JMT	
Aprobado :			
Escala 1:5	Proyecto : TBT		No. : 05.8.19-001
Formato A3	HEATER UPPER LID & CABLE PASS THROUGHS		Revisión : 2
			Hoja: 05 de: 06
			CD :

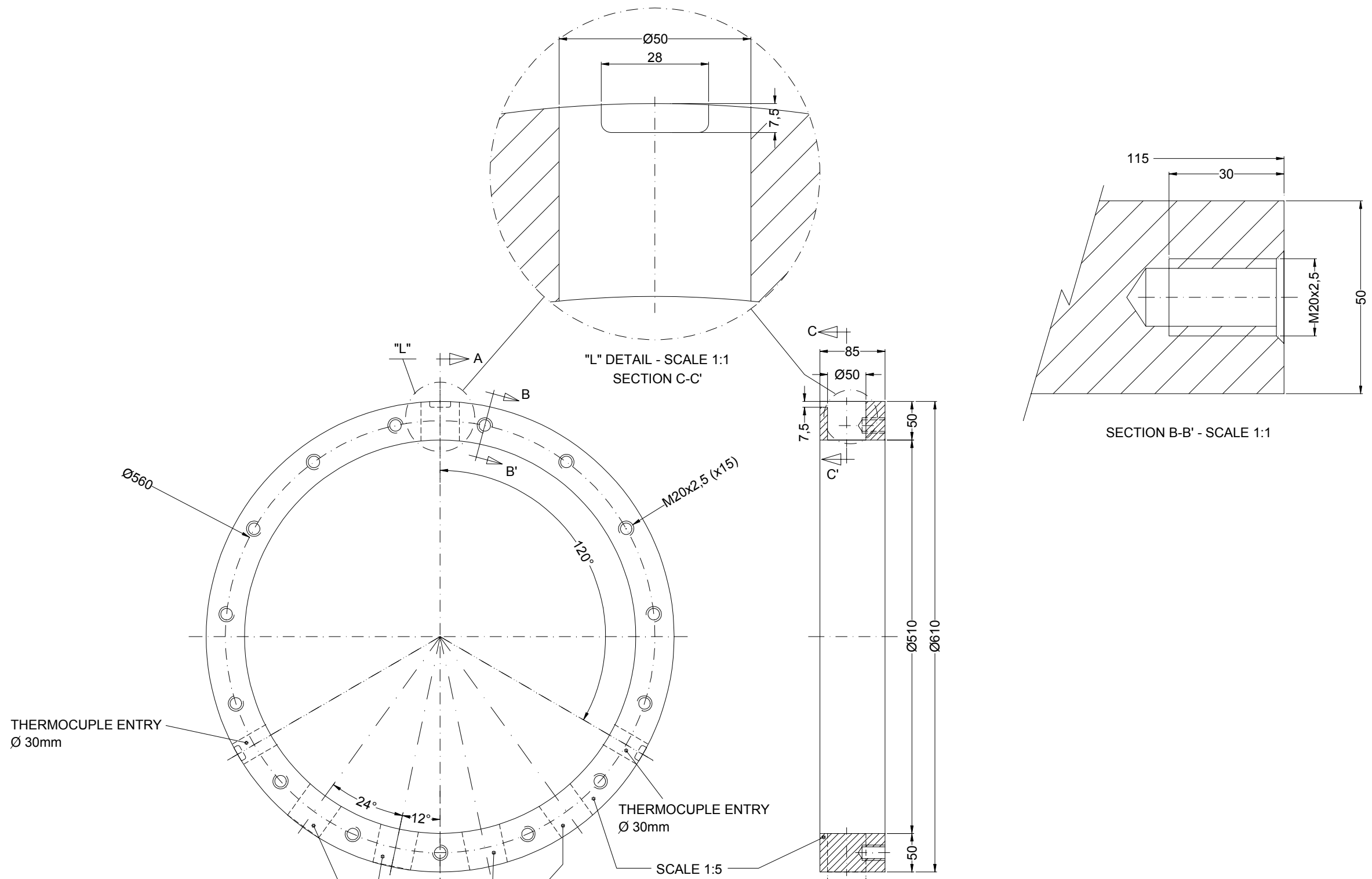

	Fecha	Firma	
Diseñado :	02-09-16		
Dibujado :	02-10-16	JMT	
Aprobado :			
Escala 1:5	Proyecto : TBT		No. : 05.8.19-001
Formato A3	HEATER UPPER RING		Revisión : 2
			Hoja: 06 de: 06
			CD :