

**International
Progress Report**

IPR-03-07

Äspö Hard Rock Laboratory

Difference flow measurements in borehole KA3376B01 at the Äspö HRL

Jari Pöllänen
Pekka Rouhiainen
PRG-Tec Oy

January 2003

Svensk Kärnbränslehantering AB

Swedish Nuclear Fuel
and Waste Management Co
Box 5864
SE-102 40 Stockholm Sweden
Tel +46 8 459 84 00
Fax +46 8 661 57 19



**Äspö Hard Rock
Laboratory**

| | |
|----------------------|----------|
| Report no. | No. |
| IPR-03-07 | F86K |
| Author | Date |
| Pöllänen, Rouhiainen | 03-01-20 |
| Checked by | Date |
| Christer Andersson | 03-01-24 |
| Approved | Date |
| Christer Svemar | 03-01-28 |

Äspö Hard Rock Laboratory

Difference flow measurements in borehole KA3376B01 at the Äspö HRL

Jari Pöllänen
Pekka Rouhiainen
PRG-Tec Oy

January 2003

Keywords: Groundwater, flow, measuerment, bedrock, borehole, electric, conductivity, single point resistance, Posiva flow log

This report concerns a study which was conducted for SKB. The conclusions and viewpoints presented in the report are those of the author(s) and do not necessarily coincide with those of the client.

Abstract

Difference Flow meter can be used for relatively fast determination of hydraulic conductivity and hydraulic head in fractures or fractured zones in cored boreholes. These measurements were carried out in borehole KA3376B01 at Äspö Hard Rock Laboratory in January 2003.

The measurements were carried out using overlapping flow logging; the flow rate into a one meter long test section was measured. Point interval was 0.1 m. The borehole was open during these measurements.

In addition to flow, single point resistance (SPR) of the bedrock was also measured. It was measured with 0.01 m point interval during the detailed flow logging. Electric conductivity (EC) and temperature of borehole water was also measured at the same time with flow measurements.

Sammanfattning

Posiva:s flödeslog/ differensflödesmetod kan användas för att relativt snabbt kunna bestämma hydraulisk konduktivitet och det absoluta vattentrycket i sprickor och sprickzoner i kärnborrhål. Metoden användes i borrhålet KA3376B01 på Äspölaboratoriet i januari 2003.

Mätningarna genomfördes genom en detaljerad överlappande loggning vilket innebär att 1 m borrhål mäts i taget och att sonden flyttas 0,1 m mellan varje ny mätning. Under mätningen är hela borrhålet öppet.

Förutom flödet mättes ”single point resistace” (SPR) i berget. Resistansen mättes med intervallet 0,01 m under flödesloggningen. Borrhålsvattnets elektriska konduktivitet (EC) och temperatur mättes också under flödesloggningen.

Contents

| | | |
|----------|--|-----------|
| | Abstract | 2 |
| | Sammanfattning | 3 |
| 1 | Introduction | 5 |
| 2 | Principles of measurement and operation | 6 |
| 3 | Equipment specifications | 8 |
| 4 | Results | 9 |
| 4.1 | Field work | 9 |
| 4.2 | Overlapping flow logging | 9 |
| 4.3 | EC and temperature of water | 10 |
| 4.4 | Transmissivity | 10 |
| 5 | Discussion and conclusions | 12 |
| | References | 13 |
| | Appendices | 14 |

1 Introduction

Difference flow meter can be used in several ways. The main measurement modes are sequential and overlapping flow logging. In sequential flow logging, both the thermal pulse- and the thermal dilution measurement methods for flow are used, which results in a lower measurement limit for flow. In overlapping flow logging, only the thermal dilution method is used to make the measurements faster but at the price of a higher measurement limit.

The overlapping flow logging was used in this study. The measurements were carried out in borehole KA3376B01 at Äspö Hard Rock Laboratory (HRL) in January 2003.

The Difference Flow meter has been used previously in Posiva's site characterisation in Finland as well as at Äspö Hard Rock Laboratory. Boreholes KLX02 in Laxemar (Rouhiainen 2000) and KOV01 in Oskarshamn (Pöllänen & Rouhiainen 2001) have also been measured using the Posiva Flow Log.

PRG-Tec Oy conducted the field work. Posiva Oy owns the Difference flow meter.

2 Principles of measurement and operation

The Posiva Flow Log consists of the Transverse flowmeter and the Difference flowmeter. Only the Difference flowmeter is discussed in this report.

Ordinary borehole flowmeters measure the accumulated flow along the borehole. However, the incremental changes of flow along the borehole are generally very small and can easily be missed unless they are measured directly. The name "Difference flowmeter" comes from the fact that this flowmeter directly measures differences of flow along the borehole. These differences of flow are seepage from the bedrock into the borehole or flows from the borehole into the bedrock.

With the flow guide of the Difference flowmeter, the flow into or out from the borehole in the test section is the only flow that passes through the flow sensor. Flow along the borehole outside the test section is directed so that it does not come into contact with the flow sensor. A set of rubber disks is used at both ends of the equipment to isolate the test section from the borehole. These guide the flow to be measured, see Figure 2-1.

The main measurement methods of the difference flow meter are the sequential and the overlapping flow logging. The sequential method is used for the determination of hydraulic conductivity and head (Öhberg, Rouhiainen 2000).

Flow rate can be measured in two main ways. Both the thermal dilution and the thermal pulse flow measuring techniques are used in sequential method. The thermal pulse method makes it possible to determine flow direction. To make measurements more quickly, only the thermal dilution method is used in the overlapping flow logging. It is mostly used to determine the exact location of hydraulically conductive fractures and to classify them by flow rates.

The overlapping flow logging was used in this study. It was used while boreholes were open. The length of the test section was 1 m and the spacing between two measuring points (depth increment) was 0.1 m.

Electric conductivity (EC) and temperature of borehole water were measured during flow logging. The occurrence of saline water in the borehole can be monitored using the EC measurements.

The single point resistance measurement (grounding resistance) is another parameter that is possible to measure with the flowmeter tool. The electrode of the single point resistance tool is located within the upper rubber disks, see Figure 2-1. This method is used for depth determination of fractures and geological structures. The point interval is 0.01 m.

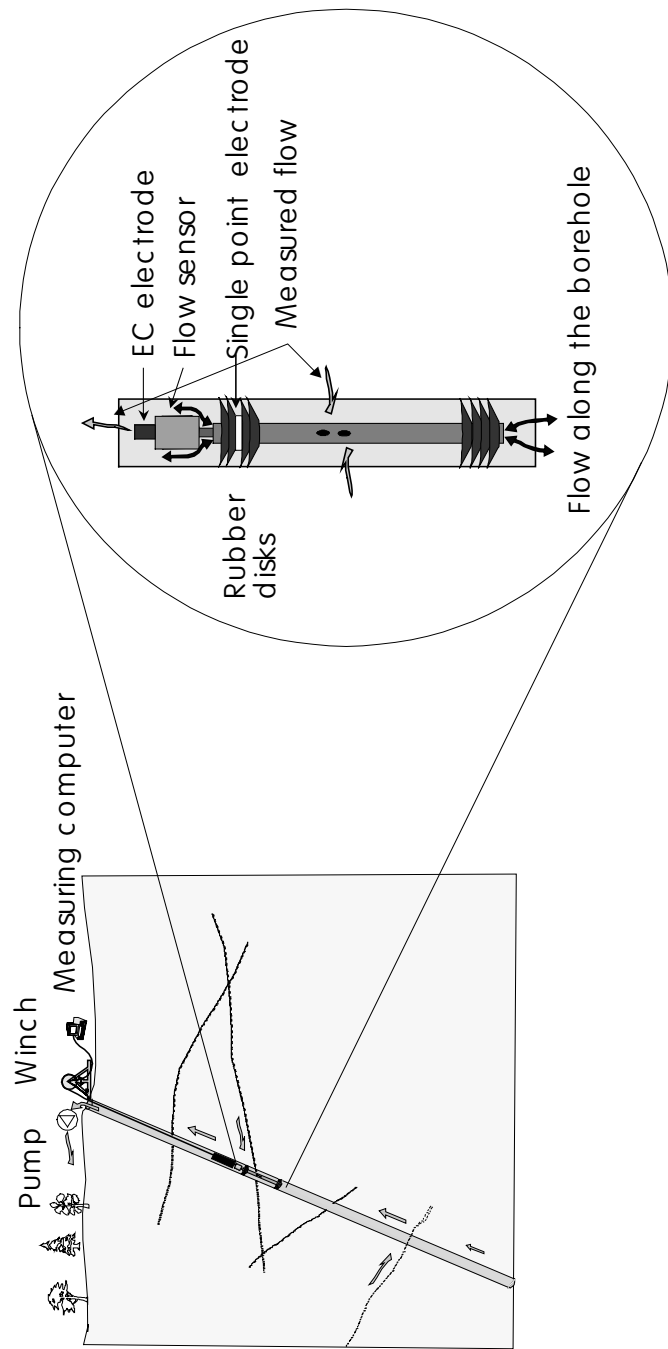

Figure 2-1 Schematic of the equipment used in the Difference flowmeter.

3 Equipment specifications

The Difference Flow meter monitors the flow of groundwater into or out from a borehole by means of a flow guide (discs). That is, the flow guide defines the test section to be measured but does not alter the hydraulic head. Groundwater flowing into or out from the test section is guided to the flow sensor. Flow is measured using the thermal pulse and/or thermal dilution methods. Measured values are sent in digital form to the PC computer (Rouhiainen, Pöllänen 1998).

| | |
|--------------------------------|---|
| Type of instrument: | Posiva Flow Log/Difference Flow meter |
| Measurable borehole diameters: | 56 mm, 66 mm and 76 mm |
| Length of test section: | A variable length flow guide is used |
| Method of flow measurement: | Thermal pulse and/or thermal dilution |
| Range of measurement: | 2 - 5000 ml/min with thermal dilution |
| Additional measurements: | Temperature, Single point resistance, conductivity of water |
| Winch: | Mount Sopris Wna 10, 0.55 kW, 220V/50Hz. Steel wire cable 1500 m, four conductors, Gerhard -Owen cable head |
| Depth determination | Based on the marked cable and on the digital depth counter |
| Logging computer: | PC, Windows 95/98/2000 |
| Software | Based on MS Visual Basic |
| Total power consumption: | 1.5 - 2.5 kW depending on the pumps |
| Method of calibration | Field calibration unit |

4 Results

4.1 Field work

The field work was carried out in the Äspö HRL in January 2003. The activity schedule is presented in Table 4-1.

Table 4-1. Difference flow measurements in the Äspö HRL. Activity schedule.

| Started Date Time | Finished Date Time | Activity |
|-------------------------|--------------------------|---|
| 14.1.2003 15:15 | | Borehole KA3376B01 was opened. |
| 14.1.2003 16:28 | | Flow rate out from the borehole was 95 l/min. |
| 14.1.2003 16:30 | 14.1.2003 24:00 | Overlapping flow logging in the borehole (Depths 78.4 m – 3.2 m). |
| 15.1.2003 7:30 | 15.1.2003 7:45 | Overlapping flow logging in the borehole (Depths 3.2 m – 1.2 m). |
| 15.1.2003 7:45 | | Flow rate out from the borehole was 95 l/min. |
| 15.1.2003 8:15 | | Borehole KA3376B01 was closed. |

4.2 Overlapping flow logging

Overlapping flow logging was performed with 1 m section length and with 0.1 m depth increments, see Appendices 1.1 – 1.4. The method gives the depth and the thickness of the conductive zones with a depth resolution of 0.1 m. To make measurements more quickly, only the thermal dilution method is used for flow determination. The test section length determines the width of a flow anomaly of a single fracture. If the distance between flowing fractures is less than the section length, the anomalies will be overlapped resulting in a stepwise flow anomaly.

The depths of flowing fractures are marked with lines in the appendices of the flow logs. A long line represents the depth of a leaky fracture, a short line denotes that the existence of a leaky fracture may be uncertain or the flow rate is uncertain i.e. the flow rate is under or over the range of measurements.

There was an increased noise level (about 1000 ml/h) in flow during the flow logging. Some small flows may be missing because of the increased noise level. An apparent reason for the increased noise level is gas. Gas outflow was visible at the borehole collar.

High flow rates were detected between depths 45 – 72 m. The upper limit of measurement was exceeded in fractures at 49.8 m, 50.5 m, 51.8 m and 57.0 m. The exact rate of flow is unknown in these cases, but it is probably larger than the presented value, see Appendices 1.3 and 3.

The result of the single point resistance is presented with flow, see Appendices 1.1 – 1.4. The electrode of the single point resistance tool is located within the upper rubber disks. Thus the depth of the resistance anomalies of the leaky fractures fit with the lower part of the flow anomalies.

4.3 EC and temperature of water

EC of borehole water was measured during the flow logging. Measurements were carried out when the flow guide was its normal configuration (with both upper and lower rubber disks). The flow guide may carry water with it making the results less representative at least at tight sections. Borehole was measured from the bottom upwards. The results are presented with flow and SPR, see Appendices 1.1 – 1.4.

Temperature of borehole water was also measured during the flow logging. The results may be unreliable at some depths for the same reason as the EC measurements, the flow guide carries water with it and there was gas at some depths (see Appendix 2). The EC values are temperature corrected to 25 °C using a mathematical model to make them more comparable with other EC measurements (Heikkonen et al. 2001).

EC and temperature were measured as supplementary methods because they didn't increase the duration of the fieldwork. More reliable results of borehole water can be obtained if the tool is used without the lower rubber disks. EC and temperature of fracture-specific water can be measured if the tool using the both sets of rubber disks is stopped on a leaky fracture.

4.4 Transmissivity

Transmissivity of fractures can be calculated on the basis of flow rates if cylindrical flow without skin zones and steady state flow are assumed (Rouhiainen 1996).

$$T=1/L*Q/(a*(h_0-h_1))$$

where

T is transmissivity,

Q is the measured flow into a section,

a is a constant depending on flow geometry ($a=2*\pi*L/\ln(R/r_0)$)

L is the length of test section,

R is radius of influence from the borehole

r is radius of borehole

h₁ is hydraulic head in the borehole,

h₀ is the head of the measured zone far from the borehole

Some assumptions have to be made for the calculation of transmissivity:

$$R/r_0=500$$

$$h_1 = 0,$$

h_0 = is the elevation of fracture in the borehole.

Transmissivity is then

$$T = Q / (h_0 \cdot 2 \cdot \pi / \ln(500))$$

Hydraulic head of a fracture far from the borehole is chosen to be the same as elevation of fracture in the borehole, because no other information is available. The calculated transmissivities are presented in Appendix 3. They are qualitative because of the assumptions presented above.

The upper limit of measurement was exceeded at depths 57.0 m, 58.1 m, 50.5 m and 49.8 m. Flow rate and transmissivity are probably larger than the specified value.

5 Discussion and conclusions

In this study Difference Flow meter with the overlapping flow logging method has been used to determine the depth and flow rate of flowing fractures. Measurements were done using 1 m section length with 0.1 m depth increments when the borehole was open, i.e. water was flowing out of it. Anomalies of open fractures were seen in flow log and in single point resistance log with high depth resolution.

Electric conductivity and temperature were also measured during the flow measurement.

The measurements were quite successful in borehole KA3376B01. Gas bubbles and high out flow rate out from the borehole increased the noise level of flow. Some small flows (< 1000 ml/h) may be missing because of the increased noise level.

Transmissivity of fractures was calculated on the basis of measured flow rates. These are qualitative because of the used assumptions.

The upper limit of measurement was exceeded at four fractures (49.8 m, 50.5 m, 51.8 m and 57.0 m). In these cases, flow rate and transmissivity are probably larger than the specified value. The total inflow from the borehole was 95 l/min. About 46 l/min was detected by the flow meter. The rest 49 l/min probably originates from the mentioned four fractures.

References

Heikkonen, J., Heikkinen, E & Mäntynen, M. 2001. Mathematical modelling of temperature adjustment algorithm for groundwater electrical conductivity on basis of synthetic water sample analysis (in Finnish). Helsinki, Posiva Oy. Working report 2002-10.

Pöllänen, J. and Rouhiainen, P. 2001. Difference flow measurements in borehole KOV01 at Oskarshamn. SKB Rapport R-01-59.

Rouhiainen, P. 1996. Difference flow measurements at the Romuvaara site in Kuhmo, Boreholes KR1-KR4, KR7-KR9. Helsinki, Posiva Oy. Work Report PATU-95-35e.

Rouhiainen, P. 2000. Difference flow measurements in borehole KLX02 at Laxemar. Äspö Hard Rock Laboratory, International Progress Report IPR-01-06.

Rouhiainen, P. and Pöllänen, J. 1998. Difference flow measurements in Äänekoski, boreholes KR4, KR12 and KR13. Posiva Oy, Working report 98-31e.

Öhberg, A. and Rouhiainen, P. 2000. Posiva groundwater flow measuring techniques. Report POSIVA 2000-12.

Appendices

| | | |
|------------|-----------|-----------------------|
| Appendices | 1.1 – 1.4 | Flow rate, EC and SPR |
| Appendix | 2 | Temperature of water |
| Appendix | 3 | Transmissivities |

ÄSPÖ, Borehole KA3376B01

2003-01-14 - 2003-01-15

Reference level = Rock surface

(Top of casing tube - Rock surface = 0.4 m)

———— Measured flow rate (section 1 m, step 0.1 m)

———— Single point resistance

⊕ Electric conductivity of borehole water

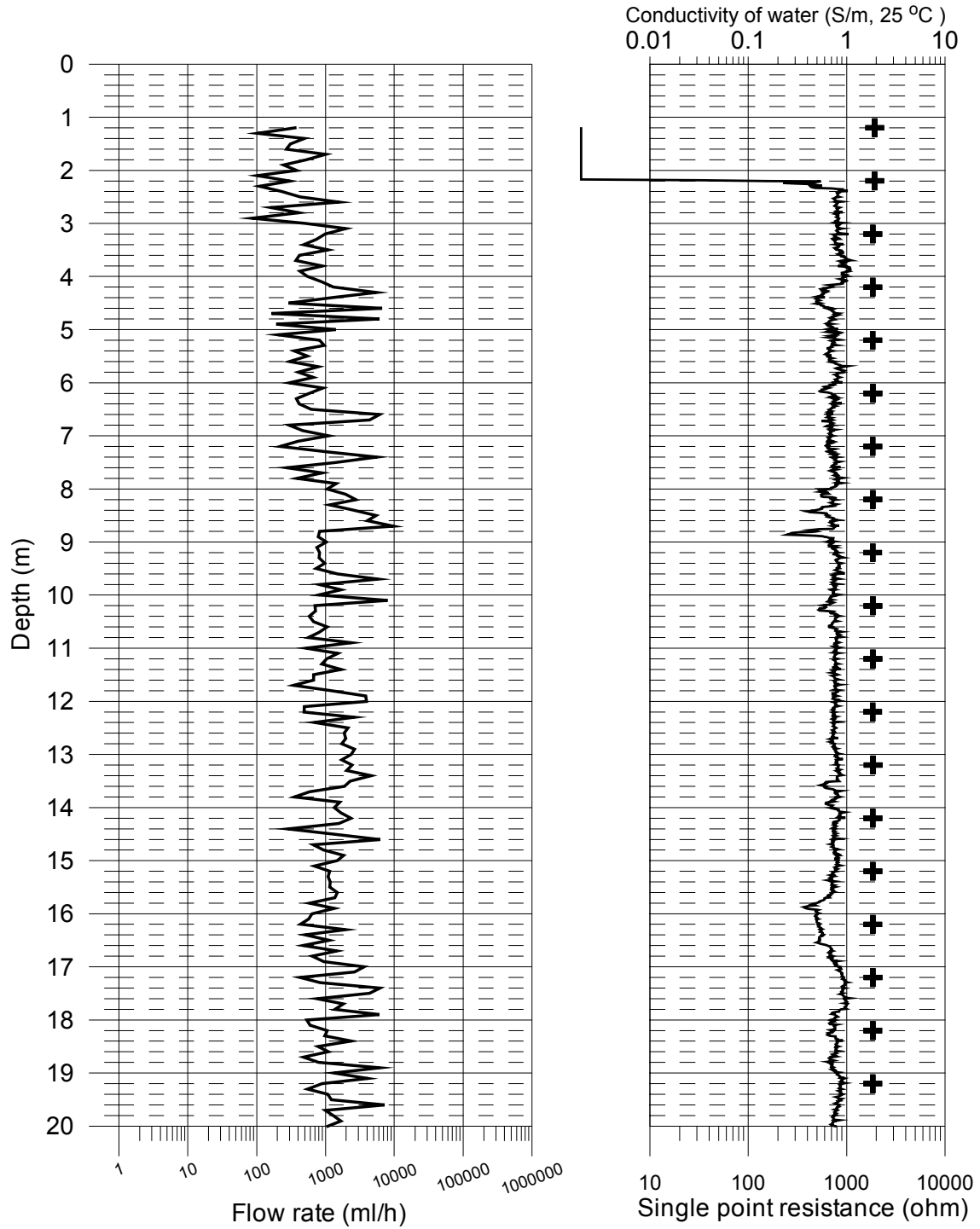

ÄSPÖ, Borehole KA3376B01

2003-01-14 - 2003-01-15

Reference level = Rock surface

(Top of casing tube - Rock surface = 0.4 m)

- Measured flow rate (section 1 m, step 0.1 m)
- Single point resistance
- + Electric conductivity of borehole water

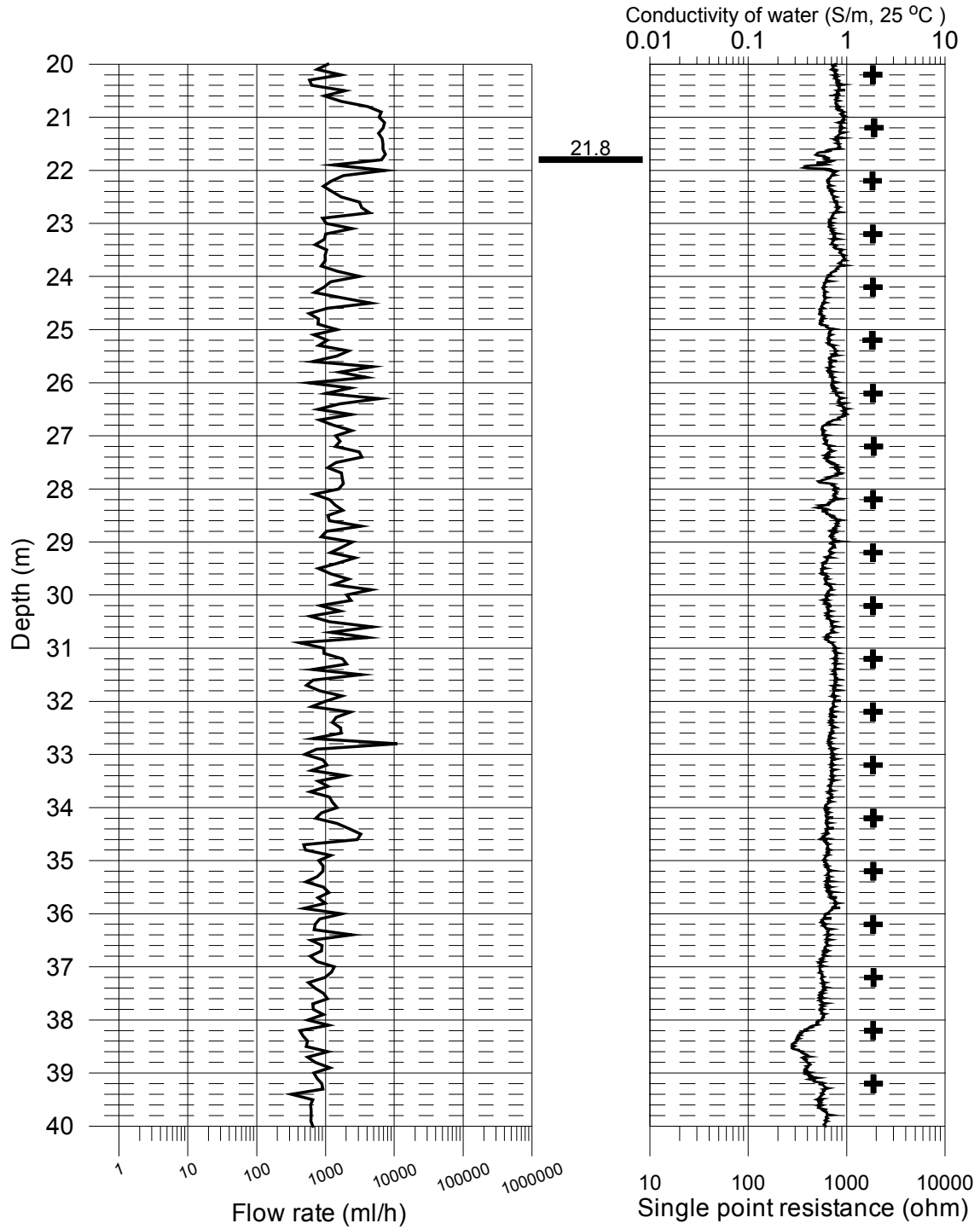

ÄSPÖ, Borehole KA3376B01

2003-01-14 - 2003-01-15

Reference level = Rock surface

(Top of casing tube - Rock surface = 0.4 m)

———— Measured flow rate (section 1 m, step 0.1 m)

———— Single point resistance

+ Electric conductivity of borehole water

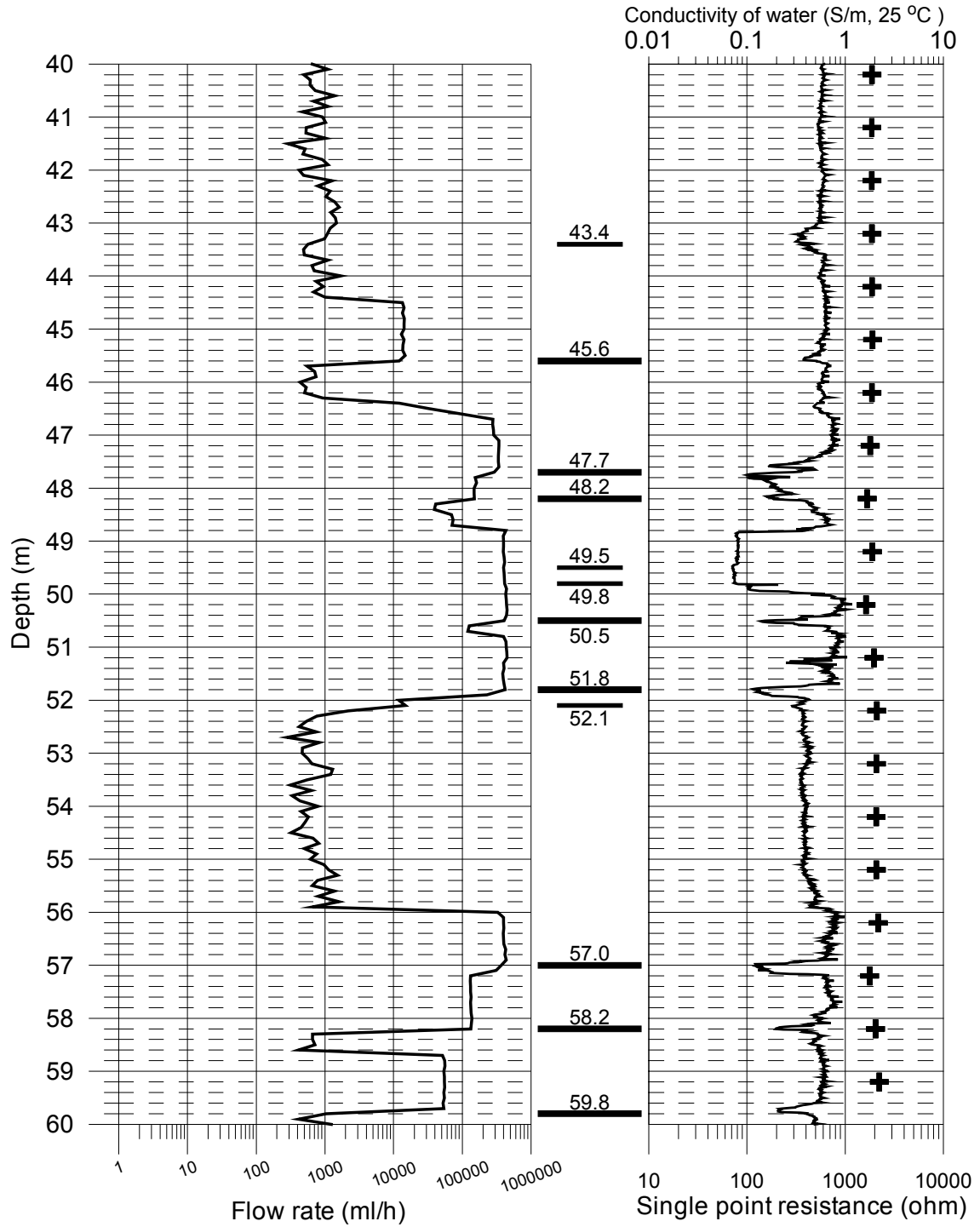

ÄSPÖ, Borehole KA3376B01

2003-01-14 - 2003-01-15

Reference level = Rock surface

(Top of casing tube - Rock surface = 0.4 m)

———— Measured flow rate (section 1 m, step 0.1 m)

———— Single point resistance

+ Electric conductivity of borehole water

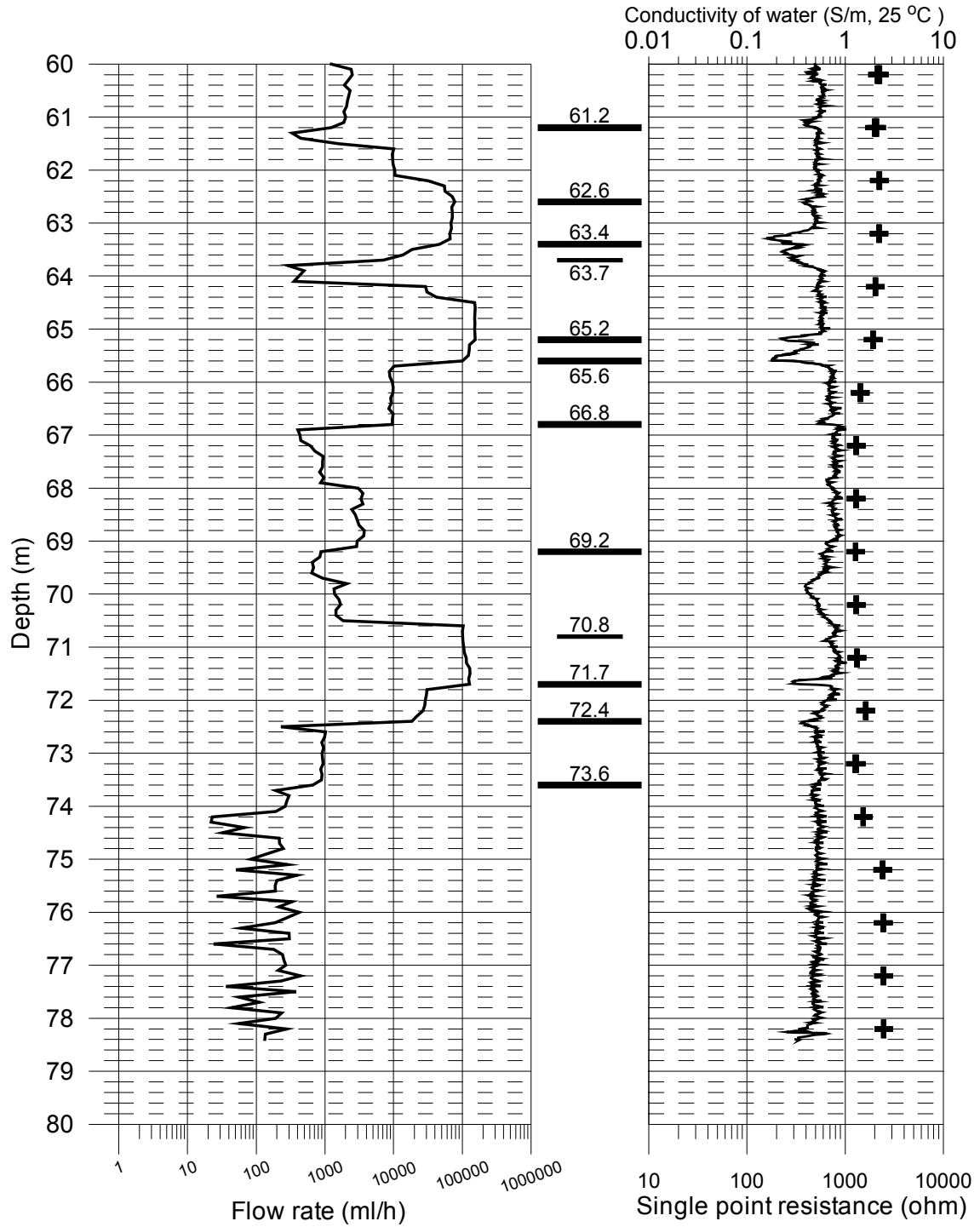

Temperature of borehole water
Äspö Tunnel, borehole KA3376B01
2003-01-14 - 2003-01-15

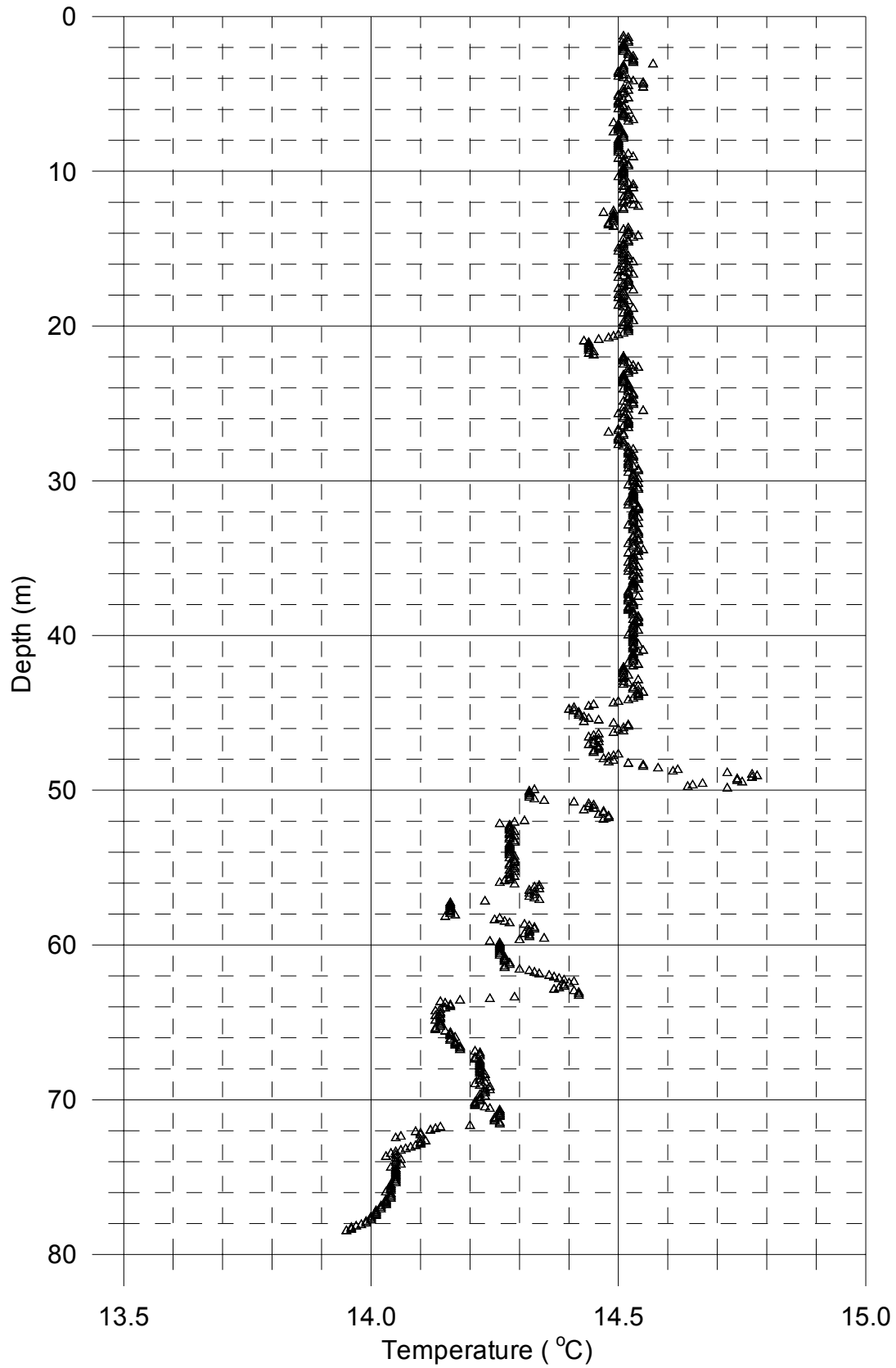

| Depth(m) | Flow(ml/h) | Elevation(m) | Transmissivity | Flow rate |
|----------|------------|--------------|----------------|-----------|
| 73.6 | 920 | -450 | 5.6E-10 | |
| 72.4 | 29000 | -450 | 1.8E-08 | |
| 71.7 | 105000 | -450 | 6.4E-08 | |
| 70.8 | 1400 | -450 | 8.5E-10 | * |
| 69.2 | 2800 | -450 | 1.7E-09 | |
| 66.8 | 9000 | -450 | 5.5E-09 | |
| 65.6 | 126000 | -450 | 7.7E-08 | |
| 65.2 | 30000 | -450 | 1.8E-08 | |
| 63.7 | 7000 | -450 | 4.3E-09 | * |
| 63.4 | 68000 | -450 | 4.2E-08 | |
| 62.6 | 9800 | -450 | 6.0E-09 | |
| 61.2 | 2000 | -450 | 1.2E-09 | |
| 59.8 | 54000 | -450 | 3.3E-08 | |
| 58.2 | 134000 | -450 | 8.2E-08 | |
| 57.0 | 400000 | -450 | 2.4E-07 | ** |
| 52.1 | 12000 | -450 | 7.3E-09 | * |
| 51.8 | 400000 | -450 | 2.4E-07 | ** |
| 50.5 | 440000 | -450 | 2.7E-07 | ** |
| 49.8 | 400000 | -450 | 2.4E-07 | ** |
| 49.5 | 70000 | -450 | 4.3E-08 | * |
| 48.2 | 150000 | -450 | 9.2E-08 | |
| 47.7 | 280000 | -450 | 1.7E-07 | |
| 45.6 | 14000 | -450 | 8.5E-09 | |
| 43.4 | 1300 | -450 | 7.9E-10 | * |
| 21.8 | 6800 | -450 | 4.2E-09 | |

* Flow rate uncertain

** Upper limit of measurement exceeded, flow rate and transmissivity probably larger than the specified value