

P-09-58

Site investigation SFR

Radar and BIPS loggings in KFR105, KFR106 and HFR106

Jaana Gustafsson, Christer Gustafsson
Malå Geoscience AB

December 2009

Svensk Kärnbränslehantering AB
Swedish Nuclear Fuel
and Waste Management Co
Box 250, SE-101 24 Stockholm
Phone +46 8 459 84 00



Site investigation SFR

Radar and BIPS loggings in KFR105, KFR106 and HFR106

Jaana Gustafsson, Christer Gustafsson
Malå Geoscience AB

December 2009

Keywords: P-report SKBDoc id 1230687, Review statement SKBDoc id 1230686, Appendix SKBDoc id 1230690, BIPS, RAMAC, Radar, TV-logging, Forsmark, SFR, AP SFR-09-011, AP SFR 09-019, Project SFR extension.

This report concerns a study which was conducted for SKB. The conclusions and viewpoints presented in the report are those of the authors. SKB may draw modified conclusions, based on additional literature sources and/or expert opinions.

Data in SKB's database can be changed for different reasons. Minor changes in SKB's database will not necessarily result in a revised report. Data revisions may also be presented as supplements, available at www.skb.se.

A pdf version of this document can be downloaded from www.skb.se.

Abstract

This report includes the data gained in geophysical logging operations performed within the site investigation at SFR in Forsmark. The logging operations presented here includes BIPS and borehole radar (RAMAC) logging in the core-drilled boreholes KFR105 and KFR106 and the percussion-drilled borehole HFR106. All measurements were conducted by Malå Geoscience AB during June and September 2009.

The objective of the radar surveys is to achieve information on the rock mass around the borehole. Borehole radar is used to investigate the nature and the structure of the rock mass enclosing the boreholes. The objective of the BIPS logging is to achieve information of the borehole including occurrence of rock types as well as determination of fracture distribution and orientation.

This report describes the equipment used as well as the measurement procedures and data gained. For the BIPS surveys, the results are presented as images. Radar data is presented in radargrams and the identified reflectors are listed.

The borehole radar data quality from KFR105, KFR106 and HFR106 was satisfying, but in parts of lower quality due to high electric conductivity of the borehole fluid. The conductive environment reduces the possibility to distinguish and interpret possible structures in the rock mass which otherwise could give a reflection. The borehole radar measurements resulted in 14 identified radar reflectors of which 7 were orientated (dip/strike). Corresponding figures for KFR106 are 17 and 9 and for HFR106 7 identified reflectors (not orientated). The basic conditions of the BIPS logging for geological mapping and orientation of structures are satisfying for the boreholes in this project, although induced affects from the drilling on the borehole walls limit the visibility.

Sammanfattning

Denna rapport omfattar geofysiska loggningar inom projektet SFR-Utbyggnad. Mätningarna som presenteras här omfattar BIPS-loggning och borrhålsradarmätningar (RAMAC) i kärnborrhålen KFR105 och KFR106 samt i hammarborrhålet HFR106. Alla mätningar är utförda av Malå Geoscience AB under juni och september 2009.

Syftet med radarmätningarna är att samla information om bergmassan runt borrhålet. Borrhålsradar används till att karakterisera bergets egenskaper och strukturer i bergmassan närmast borrhålet. Syftet med BIPS loggningen är att skaffa information om borrhålet inkluderande förekommande bergarter och bestämning av sprickors fördelning och deras orientering.

Rapporten beskriver utrustningen som använts liksom mätprocedurer och en beskrivning och tolkning av data som erhållits. För BIPS loggningarna presenteras data i form av plottar längs med borrhålet. Radardata presenteras i radargram, och en lista över tolkade radarreflektorer ges.

Borrhålsradardata från KFR105, KFR106 och HFR106 var tillfredställande, men tidvis av sämre kvalitet, troligen till stor del beroende på en elektrisk konduktiv miljö. En hög elektrisk konduktivitet minskar möjligheterna att identifiera strukturer från borrhålsradardata. 14 radarreflektorer har identifierats i KFR105, varav 7 är orienterade (strykning och stupning). Motsvarande siffror för KFR106 är 17 och 9 och för HFR106 7 identifierade reflektorer (ej orienterade). BIPS-bilderna visar att förutsättningarna för geologisk kartering och sprickorientering är goda för samtliga borrhål, även om det finns svårigheter på borrhålsväggen som försämrar kvalitén på bilderna.

Contents

1	Introduction	7
2	Objective and scope	9
3	Equipment	11
3.1	Borehole radar equipment “RAMAC”	11
3.2	TV-Camera, BIPS	11
4	Execution	13
4.1.1	RAMAC Radar	13
4.1.2	BIPS	15
4.1.3	Length measurements	16
4.2	Analyses and interpretation	17
4.2.1	Radar	17
4.2.2	BIPS	18
4.3	Nonconformities	18
5	Results	19
5.1	RAMAC logging	19
5.2	BIPS logging	23
	References	24
Appendix 1	Radar logging in KFR105. 0 to 290 m. Dipole antenna 20 MHz.	25
Appendix 2	Radar logging in KFR106. 0 to 290 m. Dipole antenna 20 MHz.	27
Appendix 3	Radar logging in HFR106. 0 to 176 m. Dipole antenna 20 MHz.	29
Appendix 4	BIPS logging in KFR105. 4 to 303 m.	31
Appendix 5	BIPS logging in KFR105, repeat section. 290 to 300 m.	49
Appendix 6	BIPS logging in KFR106. 9 to 297 m.	51
Appendix 7	BIPS logging in KFR106, repeat section. 9 to 20 m.	67
Appendix 8	BIPS logging in HFR106. 9 to 189 m.	69
Appendix 9	BIPS logging in HFR106, repeat section. 9 to 20 m.	81

1 Introduction

This document reports the results gained by BIPS and radar logging operations, which is one of the activities performed within the site investigation at SFR. The work was carried out in accordance with the activity plans AP SFR-09-011 and AP SFR-09-019. In Table 1-1 controlling documents for performing this activity are listed. Both activity plan and method descriptions are SKB's internal controlling documents.

This report includes measurements in the boreholes listed in Table 1-2.

All measurements were conducted by Malå Geoscience AB during June and September 2009. Figure 1-1 shows the borehole location.

The used investigation techniques comprised:

- Borehole radar measurements (Malå Geoscience AB's RAMAC system) with dipole and directional antennas.
- Borehole TV logging with the Borehole Image Processing System (BIPS) which is a high resolution, side viewing, colour borehole TV system.

The delivered raw and processed data have been inserted in the database of SKB (Sicada) and data are traceable by the activity plan numbers.

Table 1-1. Controlling documents for the performance of the activity.

Activity plan	Number	Version
AP SFR-09-011 BIPS och radar loggning i KFR105	AP SFR 09-011	1.0
AP SFR-09-019 BIPS och radar-loggning i KFR106 och HFR106	AP SFR-09-019	1.0
Method descriptions	Number	Version
Metodbeskrivning för TV- loggning med BIPS	SKB MD 222.006	2.0
Metodbeskrivning för borrhålsradar	SKB MD 252.020	3.0

Table 1-2. Technical data for the boreholes.

Borehole parameter	KFR105	KFR106	HFR106
Coordinates (RT 90)	6701789.85 1633072.96	6701541.18 1633592.14	6701574.11 1633579.85
Elevation	-106.82	1.06	1.27
Direction at ref. point	174.5°	195.1°	269.4°
Dip at ref. point	-10.1°	-69.9°	-60.9°
Length (m)	306.81	300.13	190.4
Casing length (m)	2.77	9.13	9.03
Borehole diameter (mm)	75.7	75.7	141-139

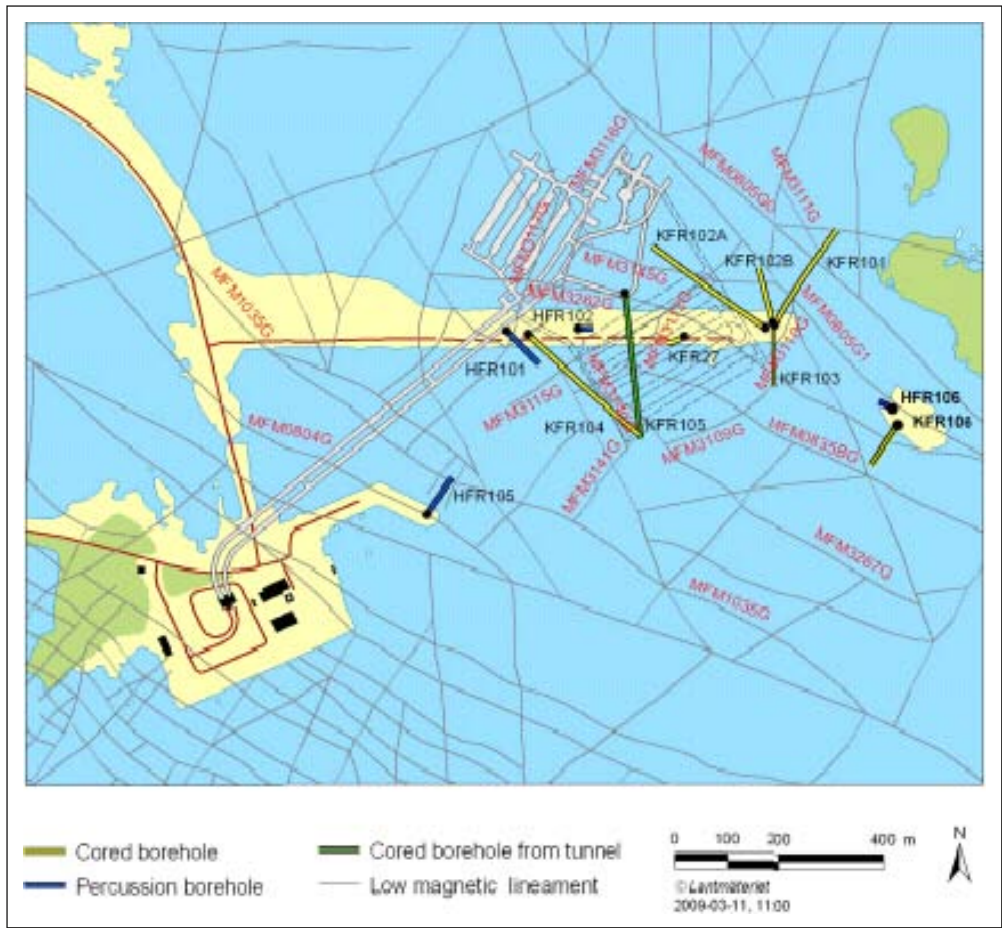

Figure 1-1. Overview over the SFR investigation area, showing the location of the boreholes KFR105, KFR106 and HFR106.

2 Objective and scope

The objective of the radar and BIPS surveys is to achieve information on the borehole conditions (borehole wall) as well as on the rock mass around the borehole. Borehole radar is engaged to investigate the nature and the structure of the rock mass enclosing the boreholes, and borehole TV for geological surveying of the borehole including determination of fracture distribution and orientation.

This report describes the equipment used as well as the measurement procedures and data gained. For the BIPS surveys, the results are presented as images. Radar data are presented in radargrams and the identified reflectors are listed.

3 Equipment

3.1 Borehole radar equipment “RAMAC”

The RAMAC GPR system owned by SKB is a fully digital GPR system where emphasis has been laid on fast survey speed and easy field operation. The system operates dipole and directional antennas (see Figure 3-1). A system description is given in the method description, SKB internal controlling document MD 252.021.

The borehole radar system consists of a transmitter and a receiver antenna. During operation an electromagnetic pulse, with centre frequency 20 MHz (dipole antenna) or 60 MHz (directional antenna) is emitted into the bedrock. Structural features, e.g. a water-filled fractures with sufficiently different electrical properties, causes reflected pulses which are recorded by the receiver.

3.2 TV-Camera, BIPS

The BIPS 1500 system used is owned by SKB and described in SKB internal controlling document MD 222.005. The BIPS method for borehole logging produces a digital scan of the borehole wall. In principle, a standard CCD video camera is installed in the probe in front of a conical mirror (see Figure 3-2). An acrylic window covers the mirror part and the borehole image is reflected through the window and displayed on the cone, from where it is recorded. During the measuring operation, pixel circles are grabbed with a resolution of one pixel per degree. The system orientates the BIPS images according to two alternative methods, either using a compass (in near-vertical boreholes) or with a gravity sensor (in inclined boreholes).

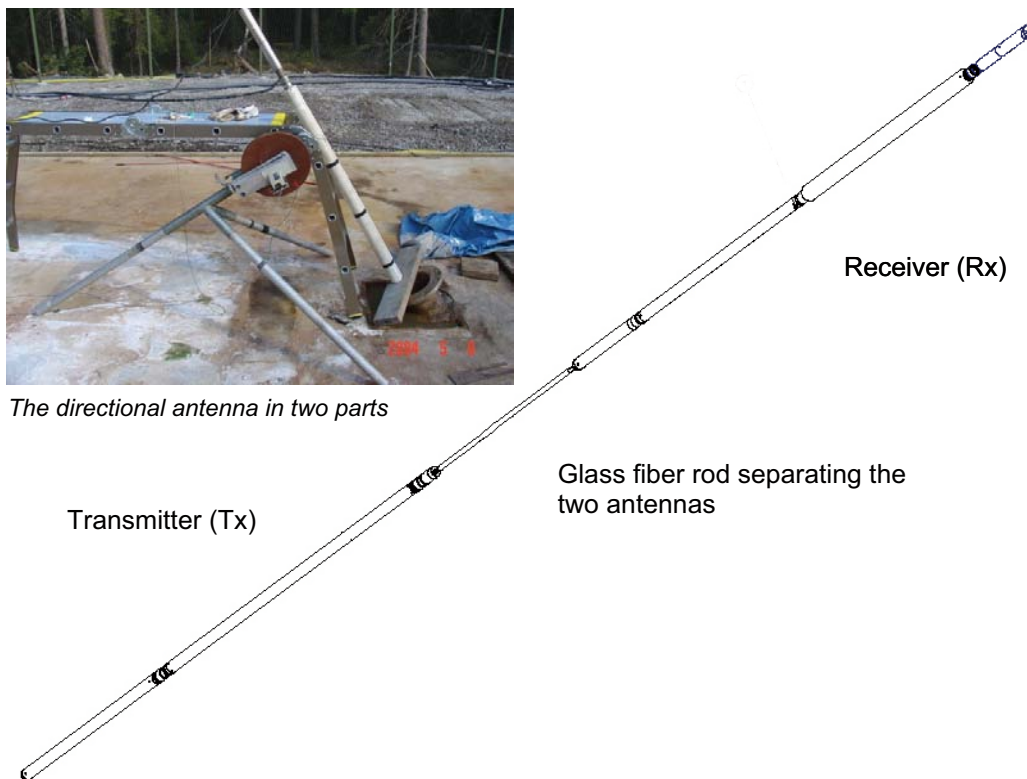

Figure 3-1. Example of a borehole radar antenna.

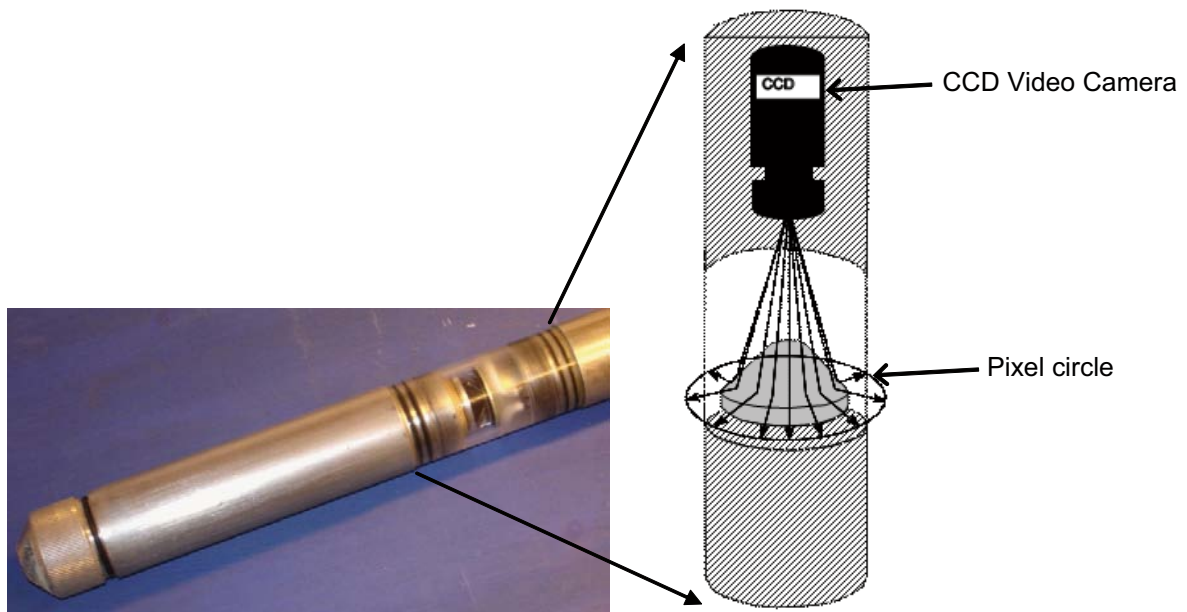

Figure 3-2. The BIP-system. To the right a sketch showing the principles of the conical mirror.

4 Execution

4.1.1 RAMAC Radar

The measurements in KFR105, KFR106 and HFR106 were carried out with dipole radar antennas with a frequency of 20 MHz. In KFR105 and KFR106 measurements were also carried out using the directional antenna, with a central frequency of 60 MHz. During logging the dipole antennas (transmitter and receiver) were lowered continuously into the borehole and data were recorded on a field computer along the measured interval. The measurement with the directional antenna is made in steps of 0.25 m, with a short pause for each measurement occasion. The antennas (transmitter and receiver, both for dipole and directional) are kept at a fixed separation by glass fiber rods according to Table 4-1. See also Figure 3-1 and 4-1.

All measurements were performed in accordance with the instructions and guidelines from SKB (internal document MD 252.020). Before the logging operation, the antennas and cable were cleaned according to the internal document SKB MD 600.004.

The functionality of the directional antenna was tested before measurements in KFR105 and KFR106. This was performed by measurements in the air, where the receiver antenna and the transmitter antenna are placed apart. While transmitting and measuring the receiver antenna is turned around and by that giving the direction from the receiver antenna to the transmitter antenna. The difference in direction is measured by compass and the result difference achieved from the directional antenna was about 2 degrees in KFR105 and 3 degrees in KFR106. This can be considered to be good, considering the disturbed environment with metallic objects etc at the test site.

For more information on system settings used in the investigation of KFR105, KFR106 and HFR106, see Tables 4-1 to 4-3.

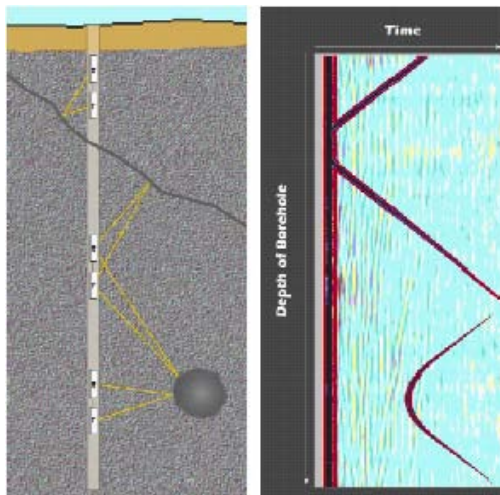

Figure 4-1. The principle of radar borehole reflection survey (left) and an example of result (right).

Table 4-1. Radar logging information from KFR105.

Site: Forsmark	Logging company: Malå Geoscience AB	
BH: KFR105	Equipment: SKB RAMAC	
Type: Directional/Dipole	Manufacturer: Malå Geoscience AB	
Operator: CG		
	Antenna	20 MHz
	Directional	
Logging date:	09-06-17	09-06-17
Reference:	Reference point	Reference point.
Sampling frequency (MHz):	615	239
Number of samples:	512	518
Number of stacks:	32	Auto
Signal position:	410.51	-1.42
Logging from (m):	288.6	296.25
Logging to (m):	6.4	6.25
Trace interval (m):	0.25	0.25
Antenna separation (m):	5.73	10.05

Table 4-2. Radar logging information from KFR106.

Site: Forsmark	Logging company: Malå Geoscience AB	
BH: KFR106	Equipment: SKB RAMAC	
Type: Directional/Dipole	Manufacturer: Malå Geoscience AB	
Operator: CG		
	Antenna	20 MHz
	Directional	
Logging date:	09-09-22	09-09-22
Reference:	T.O.C.	T.O.C.
Sampling frequency (MHz):	615	239
Number of samples:	512	518
Number of stacks:	32	Auto
Signal position:	390.48	-1.42
Logging from (m):	13.4	6.25
Logging to (m):	288.4	291.95
Trace interval (m):	0.25	0.25
Antenna separation (m):	5.73	10.05

Table 4-3. Radar logging information from HFR106.

Site: Forsmark	Logging company: Malå Geoscience AB	
BH: HFR106	Equipment: SKB RAMAC	
Type: Dipole	Manufacturer: Malå Geoscience AB	
Operator: CG		
	Antenna	20 MHz
Logging date:	09-09-23	
Reference:	T.O.C.	
Sampling frequency (MHz):	239	
Number of samples:	518	
Number of stacks:	Auto	
Signal position:	-1.42	
Logging from (m):	6.25	
Logging to (m):	182.65	
Trace interval (m):	0.25	
Antenna separation (m):	10.05	

4.1.2 BIPS

All measurements were performed in accordance with the instructions and guidelines from SKB (internal document MD 222.006). All cleaning of the probe and cable was performed according to the internal document SKB MD 600.004 before the logging operation.

During the measurement, a pixel circle with a resolution of 360 pixels/circle was used and the digital circles were stored at every 1 mm on a MO-disc in the surface unit. The maximum speed during data collection was 1.5 m/minute. A gravity sensor was used to measure the orientation of the images in boreholes KFR105, KFR106 and HFR106.

In order to control the image quality of the system, calibration measurements were performed in a test pipe before logging and after logging, see Figure 4-2 and 4-3. The results showed no differences regarding the colours and focus of the images. Results of the test loggings were included in the delivery of the raw data. The BIPS logging information is found in the header in the presentation in Appendices 4 and 9.

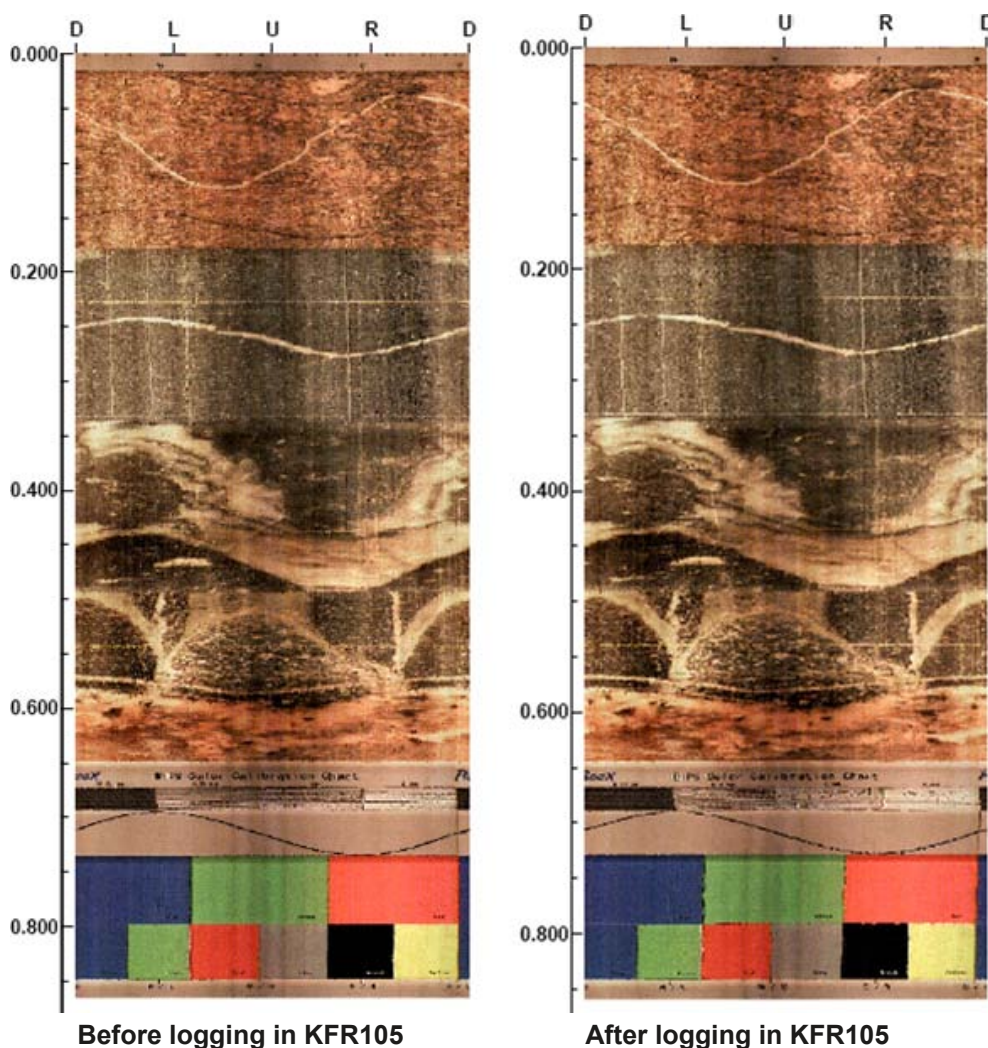

Figure 4-2. Results from logging in the test pipe before and after the logging campaign in June, 2009. The length scales are not essential in the test measurements.

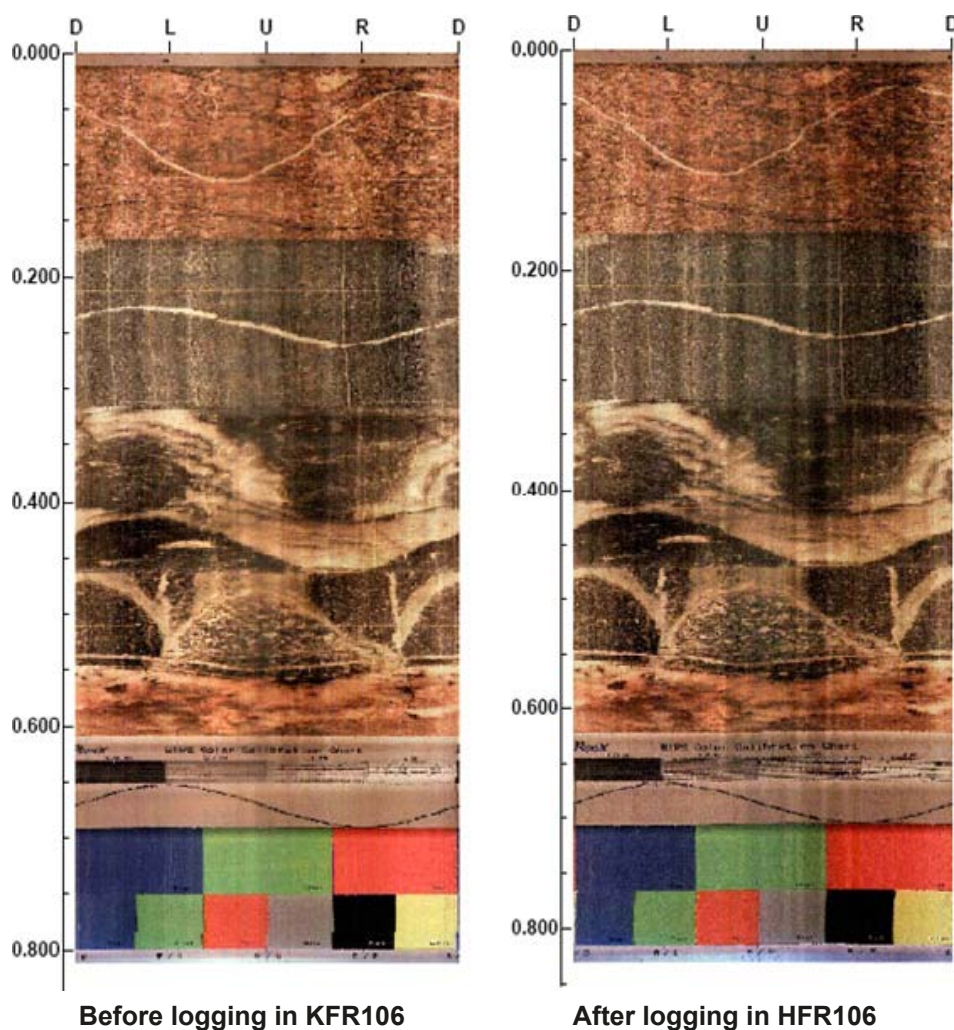

Figure 4-3. Results from logging in the test pipe before and after the logging campaign in September, 2009. The length scales are not essential in the test measurements.

4.1.3 Length measurements

During logging the length recording for the RAMAC systems is taken care of by a measuring wheel mounted on the cable winch. The logging is measured from TOC (Top of Casing) except for KFR105, in which the logging is measured from the reference point. The length is adjusted to the bottom of casing when visible in the BIPS image. During the BIPS logging in core drilled boreholes, where the reference marks in the borehole wall is visible on the image, the position where the length mark is visible is marked with scotch tape on the logging cable. During BIPS logging the measured length was adjusted to true length according to length mark visible in the BIPS image. The adjusted true length is marked with red figures in the image plot together with the non-adjusted measured length. The non-adjusted length is marked with black figures as seen in Appendix 2. The tape marks on the logging cable are then used for controlling the RAMAC measurement.

The experience we have from earlier measurements with dipole antennas in the core drilled boreholes in Forsmark and Oskarshamn is that the length divergence is less than 100 cm in the deepest parts of a 1,000 meter long borehole. The length divergence is taken into account in the resulting tables in Chapter 5.

4.2 Analyses and interpretation

4.2.1 Radar

The result from radar measurements is most often presented in the form of a radargram where the position of the probes is shown along one axis and the propagation and reflection is shown along the other axis. The amplitude of the received signal is shown in the radargram with a grey scale where black color corresponds to the large positive signals and white color to large negative signals. Grey color corresponds to no reflected signals. The presented data in this report is adjusted for the measurement point of the antennas. The measurement point is defined to be the central point between the transmitter and the receiver antenna.

The two basic patterns to interpret in borehole measurements are point and plane reflectors. In the reflection mode, borehole radar essentially gives a high-resolution image of the rock mass, showing the geometry of plane structures which may or may not, intersect the borehole (contact between layers, thin marker beds, fractures etc) or showing the presence of local features around the borehole (cavities, lenses etc). The distance to a reflecting object or plane is determined by measuring the difference in arrival time between the direct and the reflected pulse. The basic assumption is that the speed of propagation is the same everywhere. There are several ways to determine the radar wave propagation velocity. Each of them has advantages and disadvantages. In this project the velocity determination was performed by keeping the transmitter fixed in the borehole while moving the receiver downwards in the borehole. The result is plotted in Figure 4-4, and the calculation shows a velocity of 128 m/ μ s (metres per microsecond) /1/. The velocity measurement was performed with the 100 MHz antenna.

The visualization of data in Appendices 1 to 3 are made with ReflexWin, a Windows based processing software for filtering and analysis of borehole radar data. The processing steps for the data presented in Appendices 1 to 3 are given in Tables 4-4 to 4-6. The filters applied affect the whole borehole length and are not always suitable in all parts, depending on the geological conditions and conductivity of the borehole fluid. During interpretation further processing can be done, most often in form of bandpass filtering. This filtering can be applied just in parts of the borehole, where needed.

For the interpretation of the intersection angle between the borehole axis and the planes visible on the radargrams the RadinterSKB software has been used. The interpreted intersection points and intersection angles of the detected structures are presented in the Tables 5-1 to 5-3 and are also visible on the radargrams in Appendices 1 to 3.

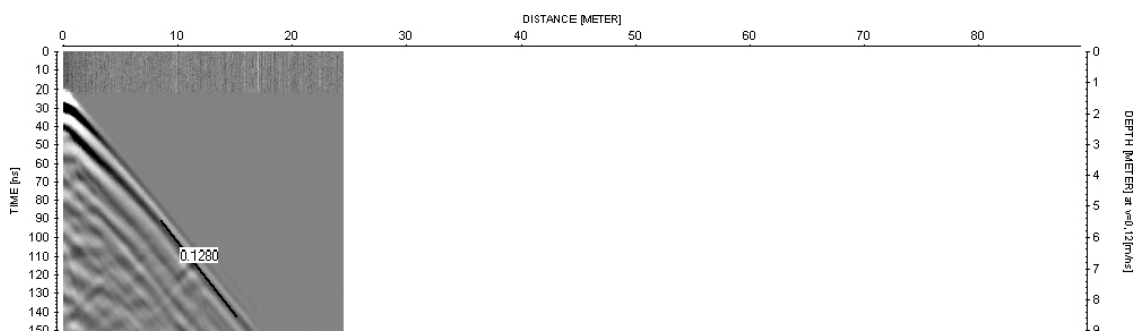

Figure 4-4. Results from velocity measurements in HFM03.

Table 4-4. Processing steps for borehole radar data from KFR105.

Site: Forsmark BH: KFR105 Type: Directional/Dipole Operator: JG	Logging company: Equipment: Manufacturer:	Malå Geoscience AB SKB RAMAC Malå Geoscience AB
	Antenna Directional	20 MHz
Processing steps	Move start time (18 samples) DC shift (410–510) Time gain (start 58 lin 60 exp 2) (FIR)	Move start time (–82) DC shift (1800–1200) Gain (Start 105 lin 3.6 exp 0.1) Bandpass

Table 4-5. Processing steps for borehole radar data from KFR106.

Site: Forsmark BH: KFR106 Type: Directional/Dipole Operator: JG	Logging company: Equipment: Manufacturer:	Malå Geoscience AB SKB RAMAC Malå Geoscience AB
	Antenna Directional	20 MHz
Processing steps	Move start time (36 samples) DC shift (410–510) Time gain (start 54 lin 100 exp 1) (FIR)	Move start time (–75) DC shift (1800–2000) Gain (Start 44 lin 5 exp 0.1)

Table 4-6. Processing steps for borehole radar data from HFR106.

Site: Forsmark BH: HFR106 Type: Dipole Operator: JG	Logging company: Equipment: Manufacturer:	Malå Geoscience AB SKB RAMAC Malå Geoscience AB
	Antenna 20 MHz	
Processing steps	Move start time (–71) DC shift (1800–2000) Gain (Start 100 lin 3 exp 0.13) Bandpass	

4.2.2 BIPS

The visualization of data is made with BDPP, a Windows based processing software for filtering, presentation and analysis of BIPS data. As no fracture mapping of the BIPS image is performed, the raw data was delivered on a CD-ROM together with printable pictures in *.pdf format before the field crew left the investigation site. The printed results were delivered with measured length, together with adjusted length according to the length marks made on the cable when logging core-drilled boreholes (where the length marks are visible in the BIPS image). For printing of the BIPS images the printing software PDPP from RaaX was used.

4.3 Nonconformities

During a revision of the method description SKB MD 252.020 some errors were discovered in the deviation file (“rikt KFR106.mag”) belonging to the directional radar logging in KFR106. These errors caused the strike/dip values, calculated by RadInter, to be incorrect. The strike/dip values from KFR106 presented in this report and stored in Sicada are therefore recalculated separately. These values are based upon the official borehole deviation data from the table denoted “Coordinate Information” in Sicada.

5 Results

The results from the BIPS measurements in KFR105, KFR106 and HFR106 were delivered as raw data (*.bip-files) together with printable BIPS pictures in *.pdf format before the field crew left the investigation site. The information of the measurements was registered in Sicada, and the CD-ROM's stored by SKB.

The RAMAC radar data for KFR105, KFR106 and HFR106 was delivered as raw data (file format *.rd3 or *.rd5) with corresponding information files (file format *.rad) on CD-ROM's to SKB before the field crew left the investigation site, whereas the data processing steps and results are presented in this report. Relevant information, including the interpretation presented in this report, was inserted into the SKB database Sicada.

5.1 RAMAC logging

The results of the interpretation of the radar measurements are presented in Tables 5-1 to 5-3. Radar data are also visualized in Appendices 1 to 3. It should be remembered that the images in Appendices 1 to 3 are a composite picture of all events 360 degrees around the borehole, and do not reflect the orientation of the structures. Only the larger clearly visible structures are interpreted in RadinterSKB. An overview of the three boreholes is given in Figure 5-1. Differences in data quality can be observed along the borehole, as seen the depth penetration is quite limited in both KFR105 and HFR106. Best data quality is seen in KFR106, where several sub-parallel structures can be identified. In Figure 5-2 a detail is shown from KFR106 with two structures visible in the directional antenna data but not in the 20 MHz data. Also observe the two larger hyperbolas (99 and 154 m depth) in HFR106 marked in Appendix 3 and seen in the overview.

A number of minor structures also exist, as indicated in Appendices 1 to 3. Often clusters of structures can be noticed, but often located so close to each other that it is impossible to distinguish one from the other. Larger structures parallel to the borehole, if present, are also indicated in Appendices 1 to 3. It should also be pointed out that an interpreted reflector always results in an intersection with the borehole (unless the reflector is strictly parallel to the hole). However, sometimes this intersection point is localized outside the range of the borehole.

The data quality from KRF105, KFR106 and HFR106 (as seen in Appendices 1 to 3) is satisfying to good, but in some parts of lower quality due to higher electrical conductivity, especially in KFR105 and HFR106. An electrical conductive environment causes an attenuation of the radar wave, which in turn decreases the penetration. This conductive environment of course also reduces the possibility to distinguish and interpret possible structures in the rock which otherwise could give a reflection. This effect is also seen in the directional antenna, which makes it more difficult to interpret the direction to the identified structures.

Tables 5-1 to 5-3 summarises the interpretation of radar data from KFR105, KFR106 and HFR105. In the table the borehole length and intersection angle to the identified structures are listed. For all boreholes the gravity roll is used in the orientation of the direction to the reflectors. As seen some radar reflectors in Tables 5-1 to 5-3 are marked with "±", which indicates an uncertainty in the interpretation of direction. In these cases there is an uncertainty in the direction to the reflectors of ±180 degrees. The direction to the object (the plane) is defined in Figure 5-3. This direction and the intersection angle are recalculated to strike and dip, also given in the tables below. The plane strike is the angle between the line of the plane's intersection with the surface and the Magnetic North direction). A strike of 0 degrees implies a dip to the east while a strike of 180 degrees implies a dip to the west (right-hand rule). The strike is measured clockwise and can vary from 0 to 359 degrees. The dip of the plane is the angle between the ground surface and the plane, and can vary from 0 to 90 degrees. Observe that the interpretation of an undulating structure can result in several different angles and different intersection lengths. An example of this phenomenon is seen in Table 5-2 and Appendix 1: the reflectors named 3 and 3x most likely originate from the same geological structure.

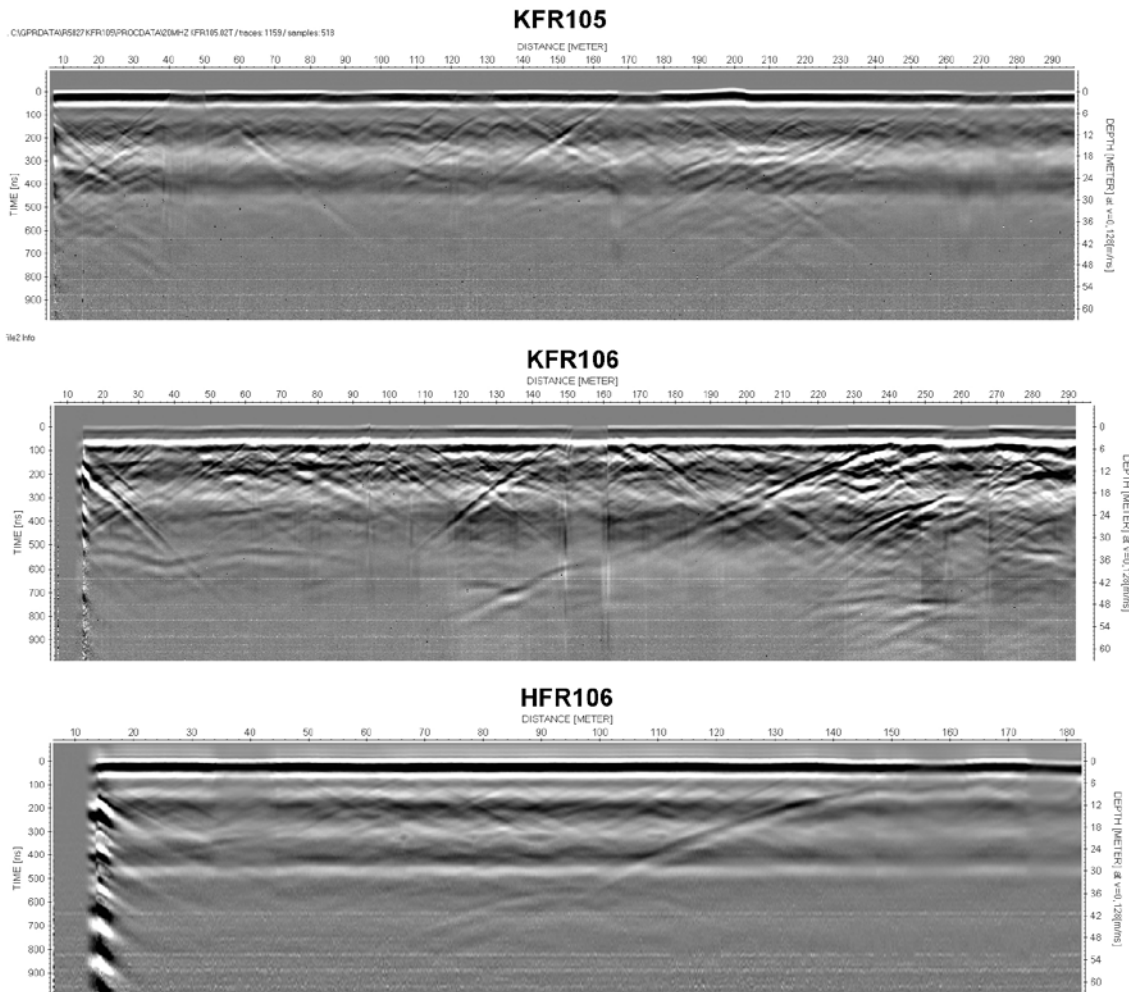

Figure 5-1. An overview (20 MHz data) of the radar data for the boreholes KFR105, KFR106 and HFR106.

Table 5-1. Interpretation of radar reflectors from the dipole antenna 20 MHz and the directional antenna 60 MHz in borehole KFR105.

Radinter model information (Directional and dipole antennas)							
Site: Forsmark							
Borehole name: KFR105							
Nominal velocity (m/ μ s): 128.0							
Name	Intersection length	Intersection angle	RadInter direction to object	Dip 1	Strike 1	Dip 2	Strike 2
4	41.2	55	177 \pm	46	263	65	79
3	47.6	57	327 \pm	72	62	54	282
12	61.7	61					
11	105.9	63					
10	112.3	59					
1	166.7	36	144	43	304		
2	173.6	46	171	38	270		
13	200.1	60	327 \pm	74	63	57	278
14	200.3	65					
7	268.6	25	150 \pm	33	316	45	39
6	271.0	48					
9	277.9	66					
5	296.0	58	171 \pm	50	266	67	75
8	361.0	9					

Table 5-2. Interpretation of radar reflectors from the dipole antenna 20 MHz and the directional antenna 60 MHz in borehole KFR106.

Radinter model information (Directional and dipole antennas)							
Site: Forsmark							
Borehole name: KFR106							
Nominal velocity (m/μs): 128.0							
Name	Intersection length	Intersection angle	RadInter direction to object	Dip 1	Strike 1	Dip 2	Strike 2
4	-705.6	3					
15	37.7	55					
5	41.3	75	249	20	239		
6	47.6	53					
7	71.6	45					
8	85.3	57	174 ±	13	89	53	280
9	111.6	69	201 ±	7	201	41	296
3	147.5	12	105 ±	73	24	84	213
2	157.3	50	9 ±	61	292	20	122
13	169.1	41					
3x	203.2	7					
10	206.9	55	336 ±	55	270	18	56
11	223.3	75	174 ±	13	89	53	280
12	250.7	58	273 ±	39	229	37	349
1	261.7	24	48	81	330		
14	264.5	62					
16	288.2	49					

Table 5-3. Interpretation of radar reflectors from the dipole antenna 20 MHz in borehole HFR106.

Radinter model information (Directional and dipole antennas)		
Site: Forsmark		
Borehole name: HFR106		
Nominal velocity (m/μs): 128.0		
Name	Intersection length	Intersection angle
1	37.5	59
2	60.8	67
3	73.4	63
4	96.2	52
5	127.8	55
6	136.4	53
7	142.7	53
Obj1	98.8	
Obj2	154.2	

Finally, the structures considered as the most important (clear in the radargram, identified with both antenna frequencies, stretching out far from the borehole wall etc) are listed in Table 5-4.

Table 5-4. Some important structures in the boreholes.

Borehole	KFR105	KFR106	HFR106
Structures	2, 3, 6, and 7	1, 2, 3, 3x, and 4	1, 5 and 7

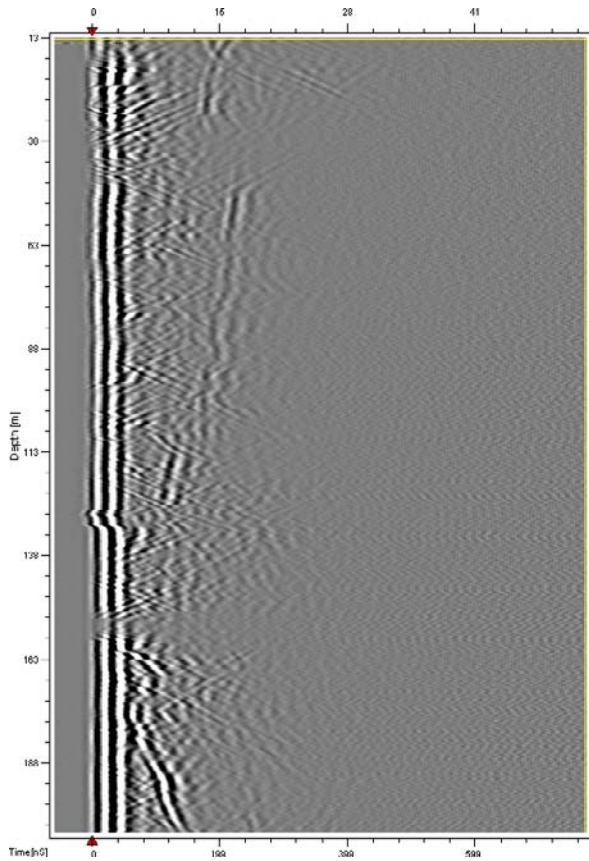

Figure 5-2. Two clear structures in KFR106 (3 and 3x) visible in the directional antenna data but not in the 20 MHz data.

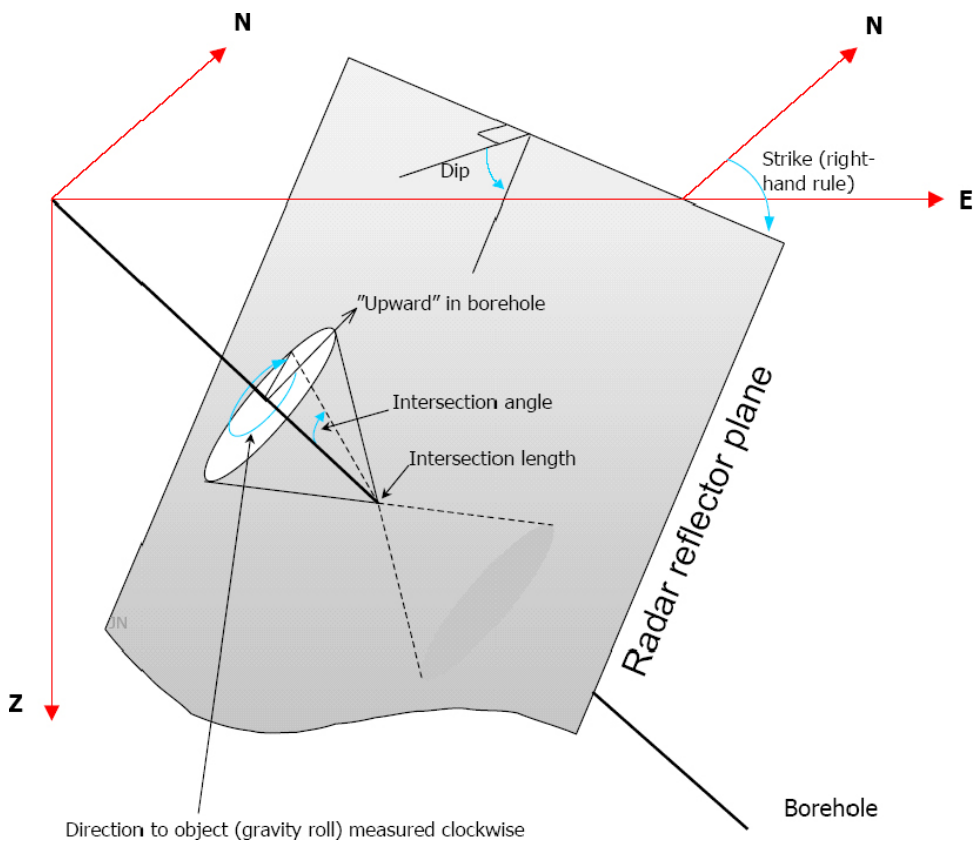

Figure 5-3. Definition of the direction to a reflector (gravity roll) as presented in Tables 5-1 to 5-3.

5.2 BIPS logging

The BIPS pictures are presented in Appendices 4 to 9. To get best possible length accuracy, the BIPS images are adjusted to the reference marks performed during the drilling face and visible on the BIPS images. In the percussion-drilled borehole HFR106 there are no marks on the borehole wall. The length adjustment is therefore performed on the same way as for the radar logging, using previous tape marks on the logging cable. The adjusted true length is marked with red figures in the image plot together with the non-adjusted measured length. The non-adjusted length is marked with black figures.

In order to control the image quality of the system, calibration measurements were performed in a test pipe before logging the first borehole and after logging of the last borehole in the campaign. The resulting images displayed no difference regarding the colours and focus of the images. The results of the test logging were included in the delivery of the field data and are also presented in Figures 4-2 and 4-3 in this report. Values for the inclination and azimuth of the boreholes, presented in the appendices, are based on preliminary values.

The BIPS images show generally acceptable quality for all logged boreholes. However, there always exists mud that covers the lowermost part of the boreholes, especially at the very bottom. In KFR105 the images are partly affected by the induced discoloring on the walls caused by the drilling.

To check the gravity sensor (tool face orientation), BIPS logging has been performed in a repeat section over a distance of 10 meters in the borehole. The main aim for the repeat section is to get a record of the tool face orientation. The repeat sections for the boreholes are presented in Appendix 5, 7 and 9. Features visible in both images from the two runs have been compared. The results are presented in Table 5-5 to 5-7 and shows that the accuracy of the orientation of the images is within the expected accuracy of the BIPS system. The maximum difference is observed in KFR106 and amounts to ca seven degrees.

Table 5-5. Differences in tool face orientation between the delivered logging and repeat section for borehole KFR105.

Feature in KFR105 at borehole length (m)	Tool face orientation in delivered picture (deg)	Tool face orientation in repeat section (deg)	Difference between the two runs (deg)
291.7	103.2	103.8	-0.6
292.7	110.8	109.5	1.3
294.8	317.2	315.9	1.3
295.5	151.1	148.5	2.6
296.3	190.1	188.2	1.9
298.0	215.2	213.4	1.8

Table 5-6. Differences in tool face orientation between the delivered logging and repeat section for borehole KFR106.

Feature in KFR106 at borehole length (m)	Tool face orientation in delivered picture (deg)	Tool face orientation in repeat section (deg)	Difference between the two runs (deg)
10.3	73.2	69.6	3.6
12.3	207.3	211.1	-3.8
14.5	125.2	128.9	-3.7
15.6	150.5	154.3	-3.8
18.1	205.2	208.6	-3.4
19.5	276.2	283.1	-6.9

Table 5-7. Differences in tool face orientation between the delivered logging and repeat section for borehole HFR106.

Feature in HFR106 at borehole length (m)	Tool face orientation in delivered picture (deg)	Tool face orientation in repeat section (deg)	Difference between the two runs (deg)
9.9	305.8	305.7	0.1
11.6	239.4	237.8	1.6
13.8	207.8	209.5	-1.7
15.5	148.3	145.0	3.3
16.7	267.8	270.4	-2.6
17.5	306.9	305.2	1.7

References

- /1/ **Gustafsson C, Nilsson P, 2003.** Geophysical Radar and BIPS logging in borehole HFM01, HFM02, HFM03 and the percussion drilled part of KFM01A. SKB P-03-39. Svensk Kärnbränslehantering AB.

Radar logging in KFR105. 0 to 290 m. Dipole antenna 20 MHz.

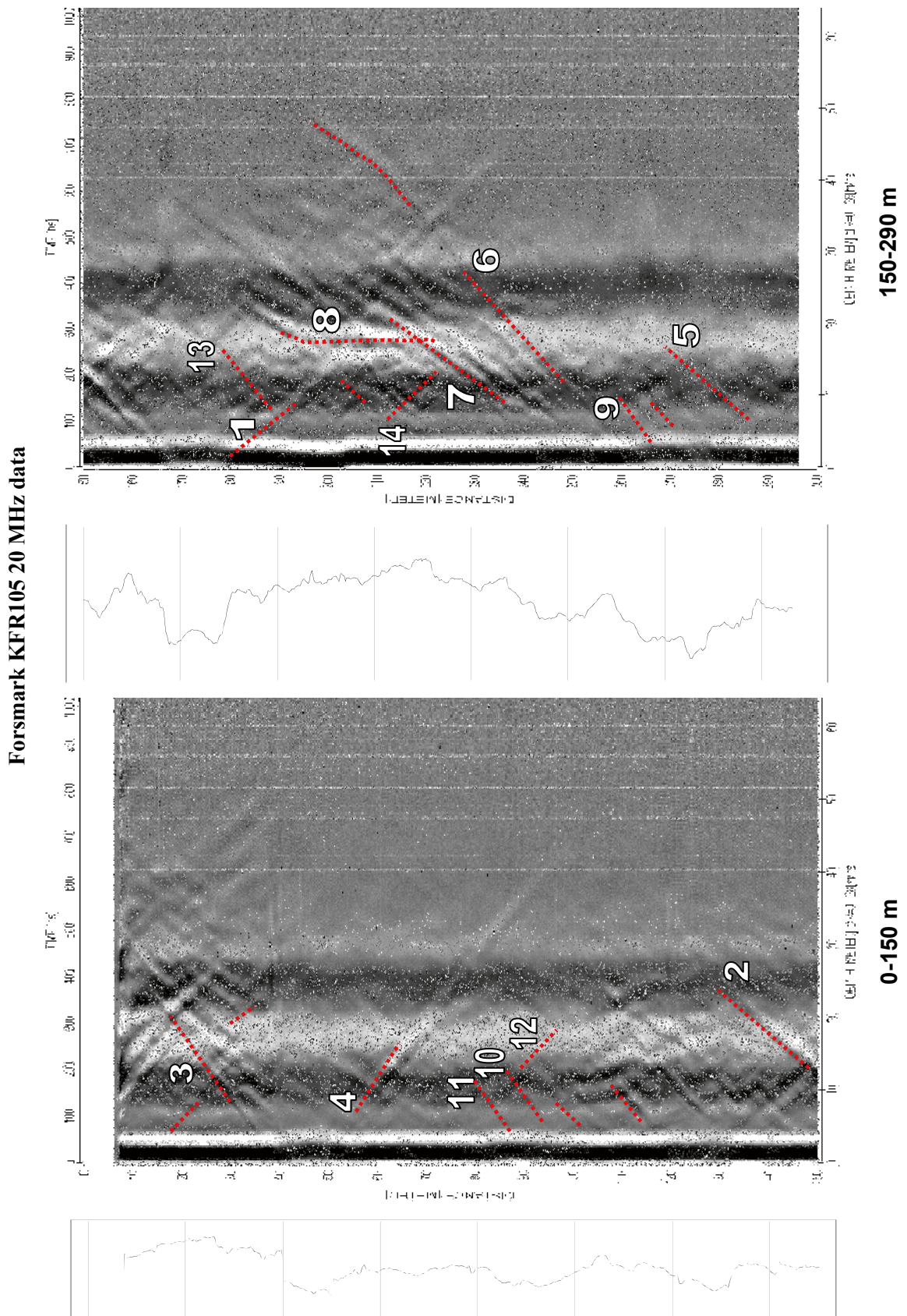

Radar logging in KFR106. 0 to 290 m. Dipole antenna 20 MHz.

Forsmark KFR106 20 MHz data

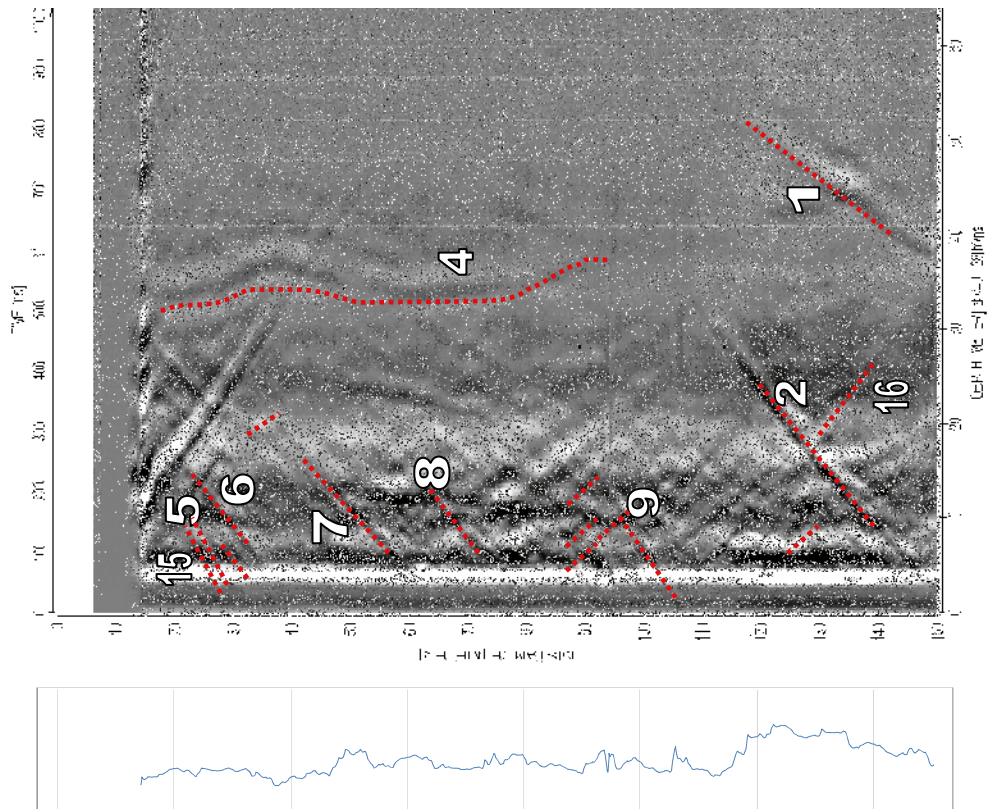
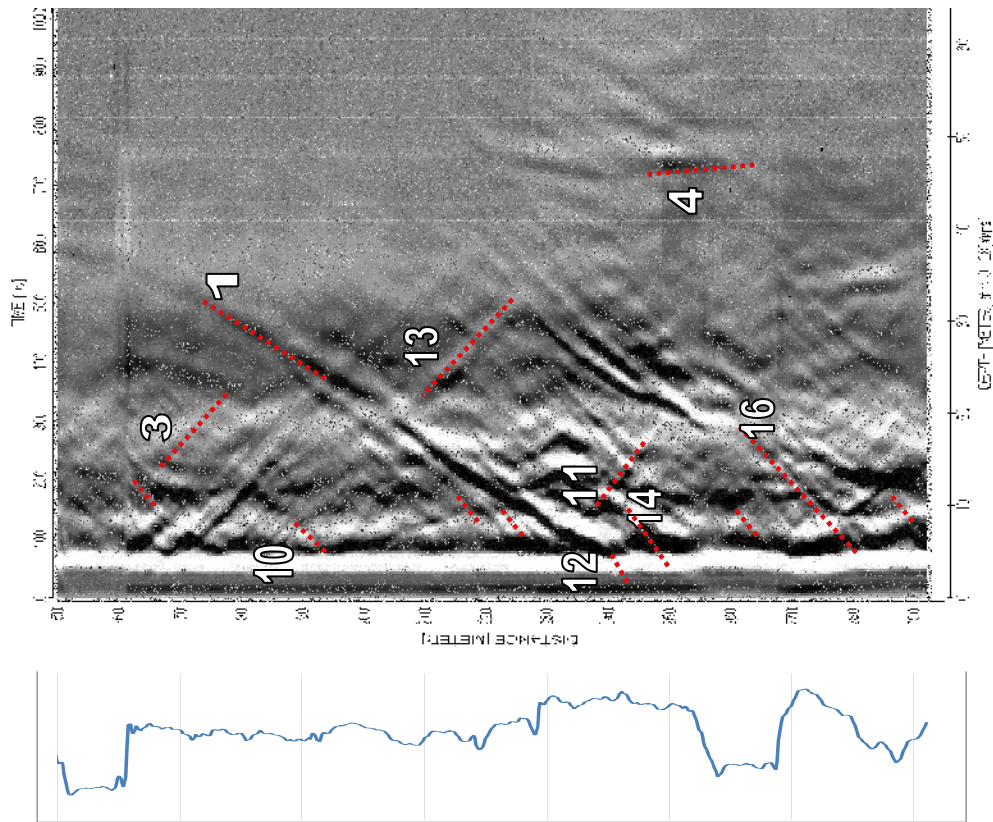

Radar logging in HFR106. 0 to 176 m. Dipole antenna 20 MHz.

Forsmark HFR106 20 MHz data

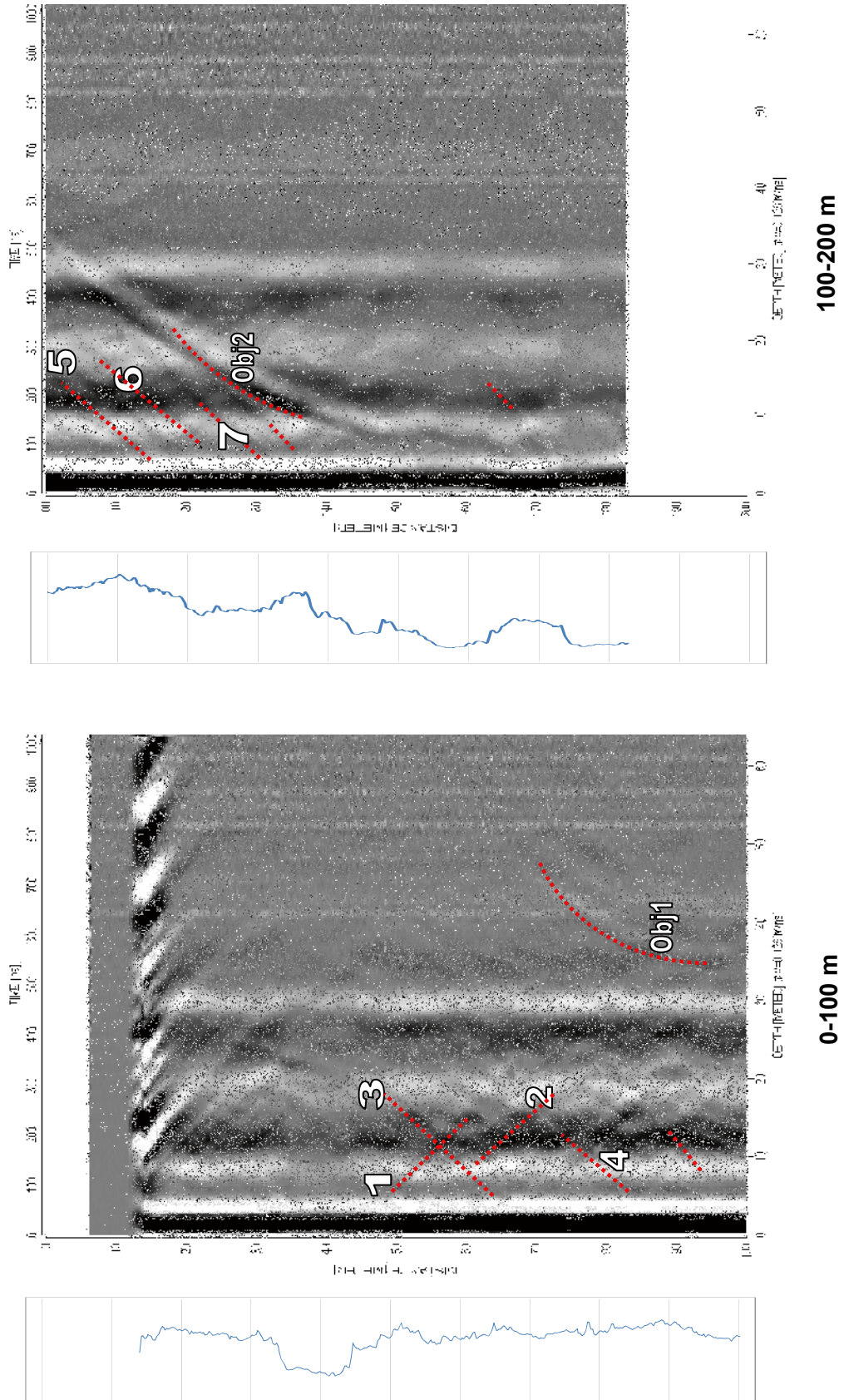

BIPS logging in KFR105. 4 to 303 m.

Project name: SFR

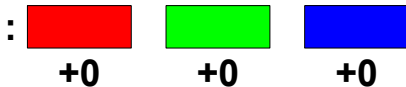
Image file : c:\temp\bipsda~1\kfr105.bip
BDT file : c:\temp\bipsda~1\kfr105.bdt
Locality : SFR
Bore hole number : KFR105
Date : 09/06/16
Time : 12:16:00
Depth range : 4.000 - 303.492 m
Azimuth : 174
Inclination : -10
Diameter : 76.0 mm
Magnetic declination : 0.0
Span : 4
Scan interval : 0.25
Scan direction : To bottom
Scale : 1/25
Aspect ratio : 175 %
Pages : 16
Color : 

Project name: SFR
Bore hole No.: KFR105

Azimuth: 174 Inclination: -10

Depth range: 0.000 - 20.000 m

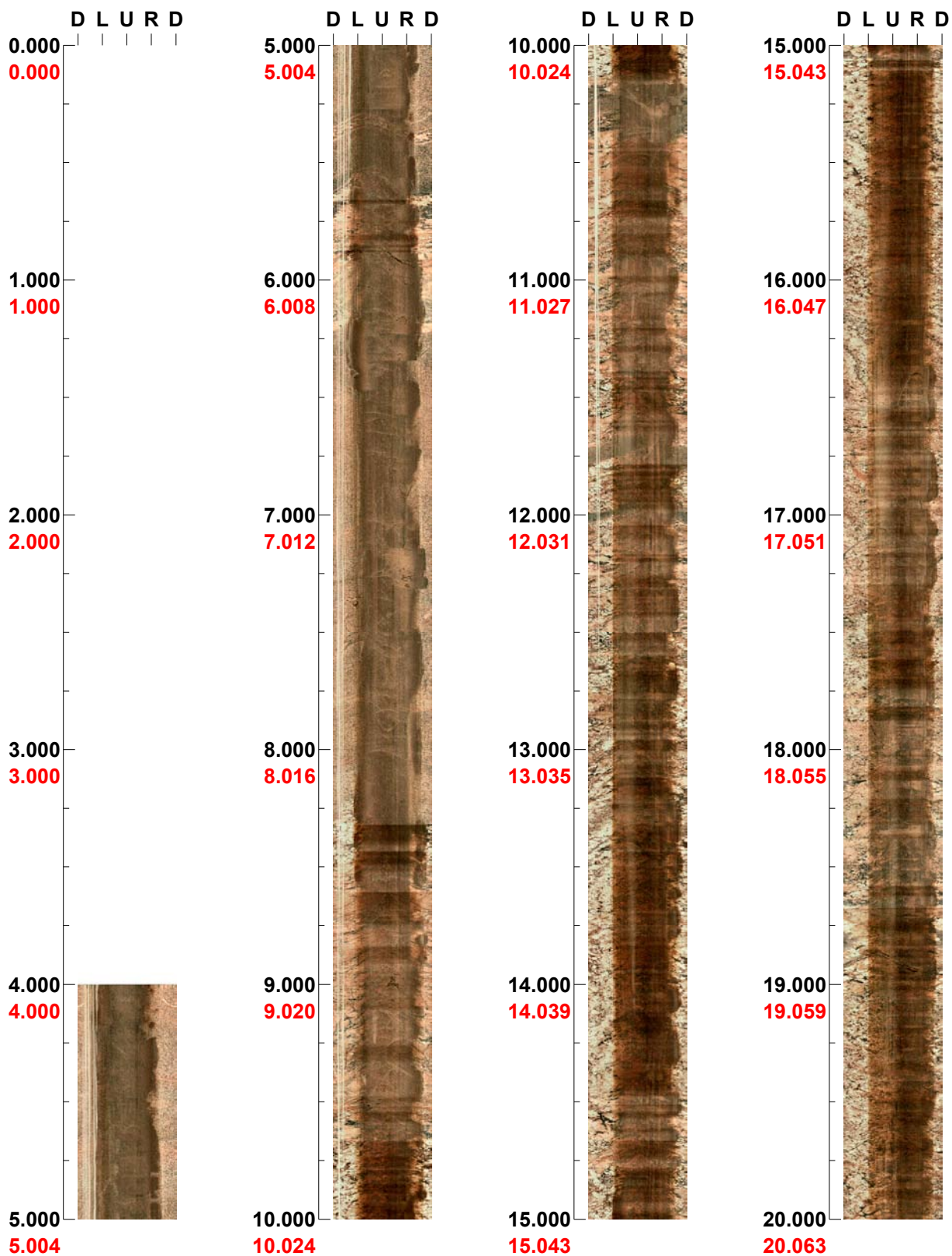

Project name: SFR
Bore hole No.: KFR105

Azimuth: 174

Inclination: -10

Depth range: 20.000 - 40.000 m

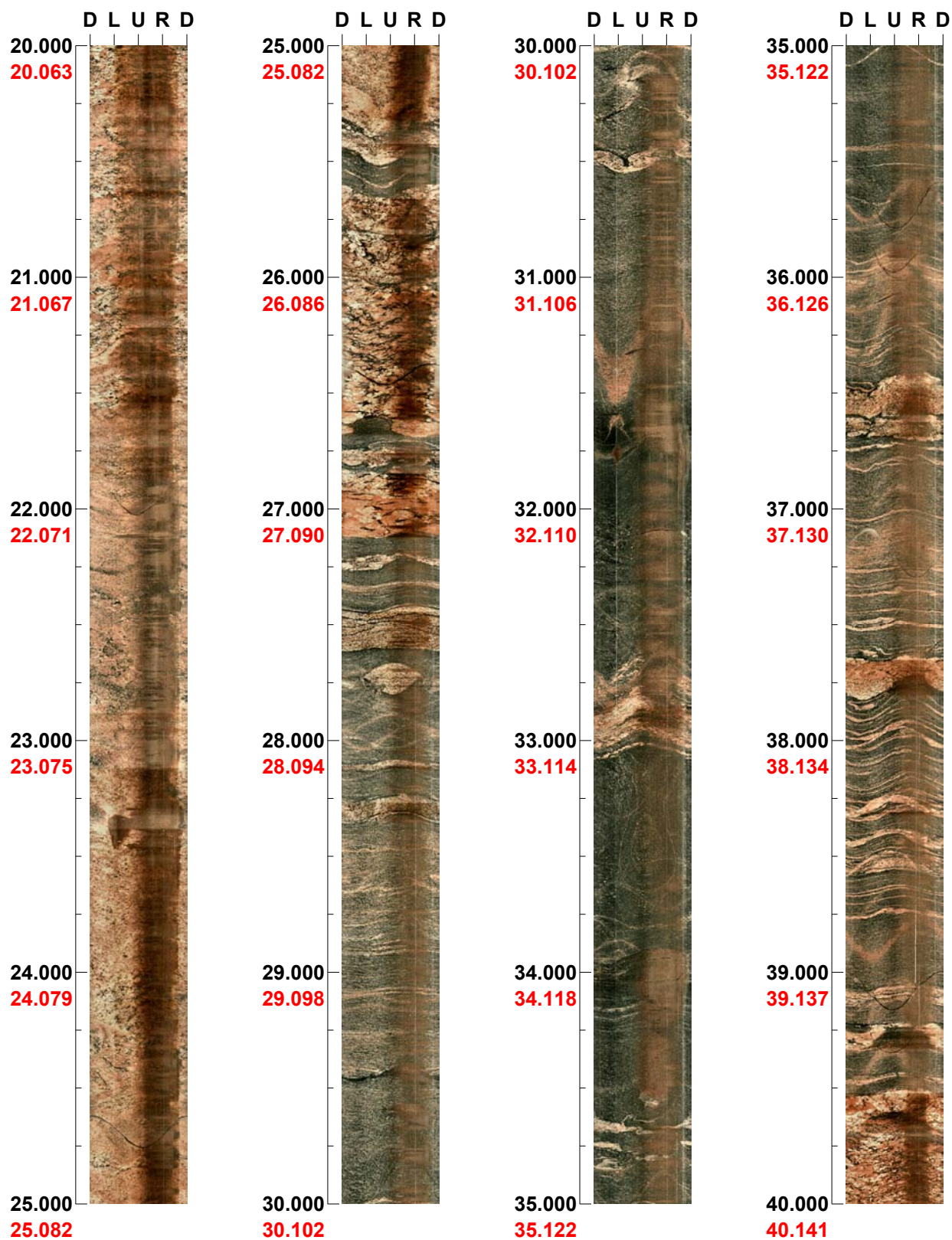

Project name: SFR
Bore hole No.: KFR105

Azimuth: 174

Inclination: -10

Depth range: 40.000 - 60.000 m

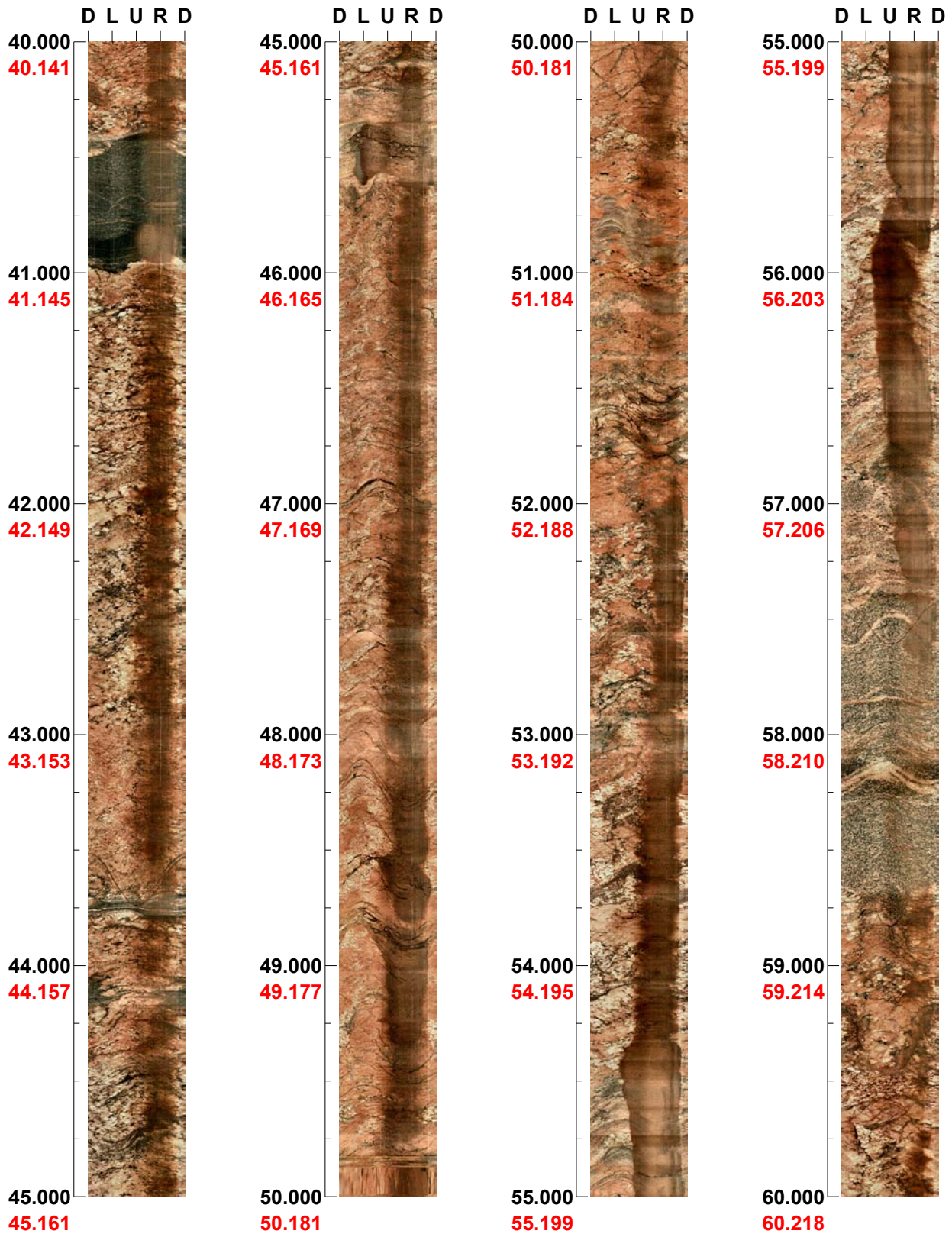

Project name: SFR
Bore hole No.: KFR105

Azimuth: 174

Inclination: -10

Depth range: 60.000 - 80.000 m

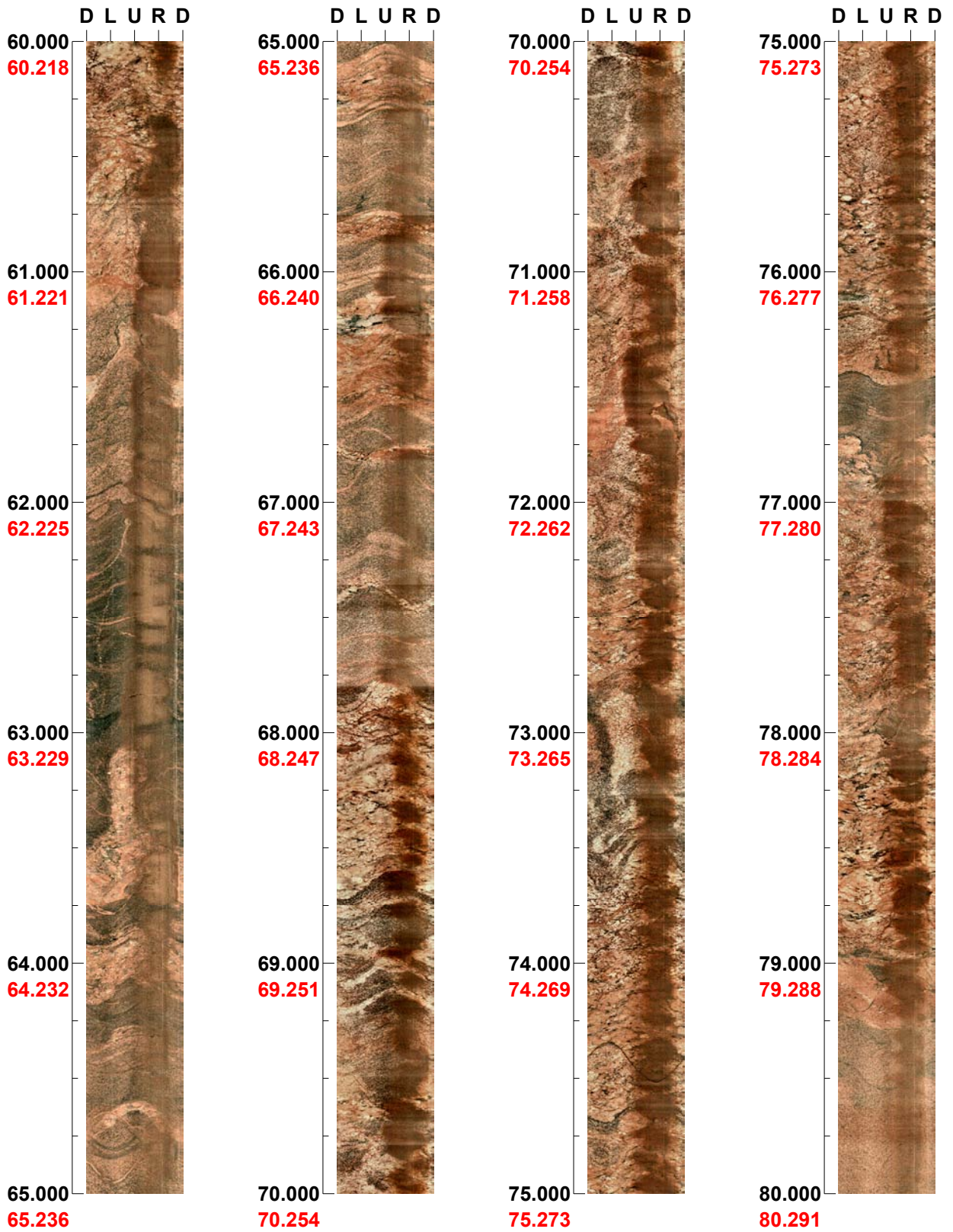

Project name: SFR
Bore hole No.: KFR105

Azimuth: 174 Inclination: -10

Depth range: 80.000 - 100.000 m

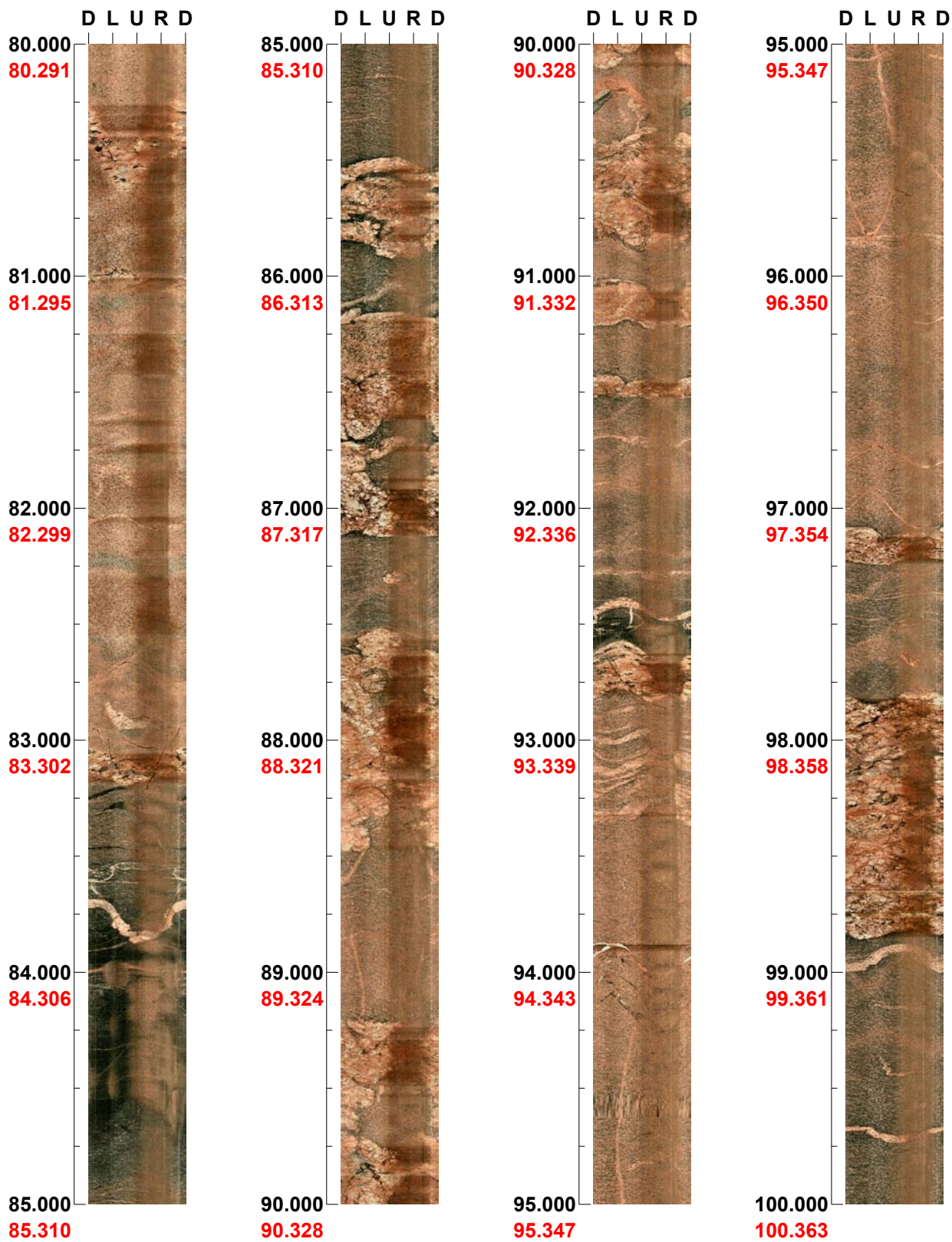

Project name: SFR
Bore hole No.: KFR105

Azimuth: 174

Inclination: -10

Depth range: 100.000 - 120.000 m

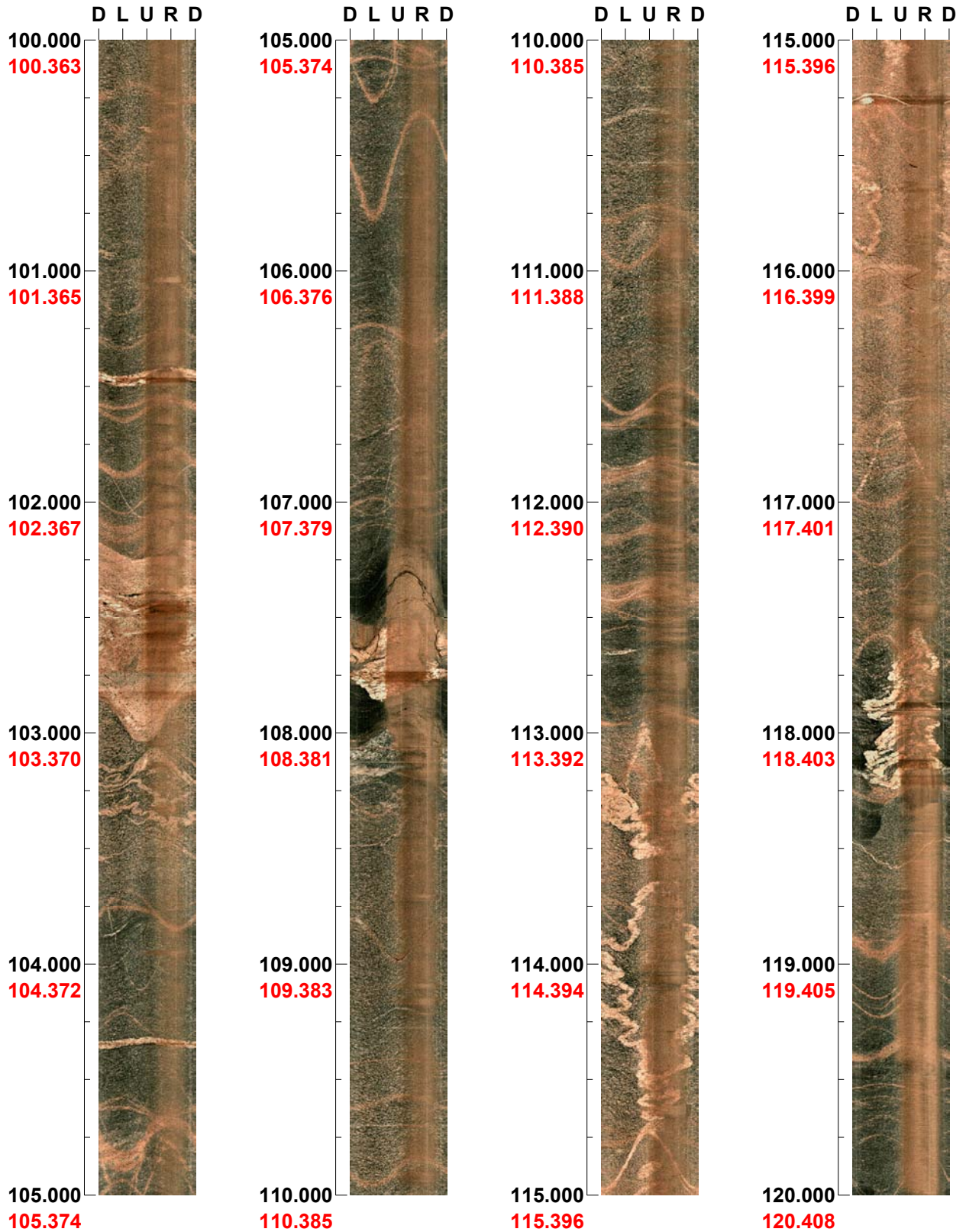

Project name: SFR
Bore hole No.: KFR105

Azimuth: 174 Inclination: -10

Depth range: 120.000 - 140.000 m

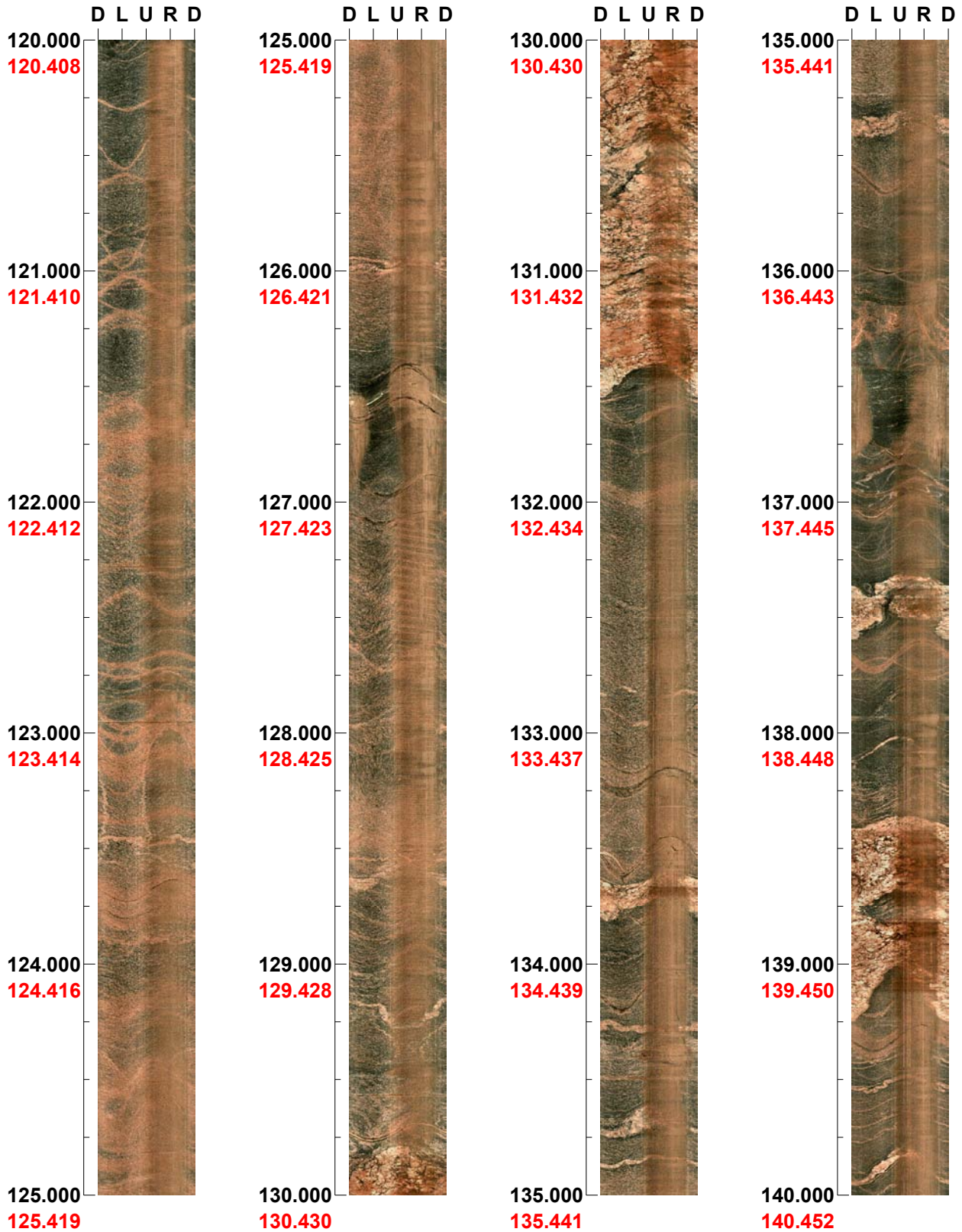

Project name: SFR
Bore hole No.: KFR105

Azimuth: 174 Inclination: -10

Depth range: 140.000 - 160.000 m

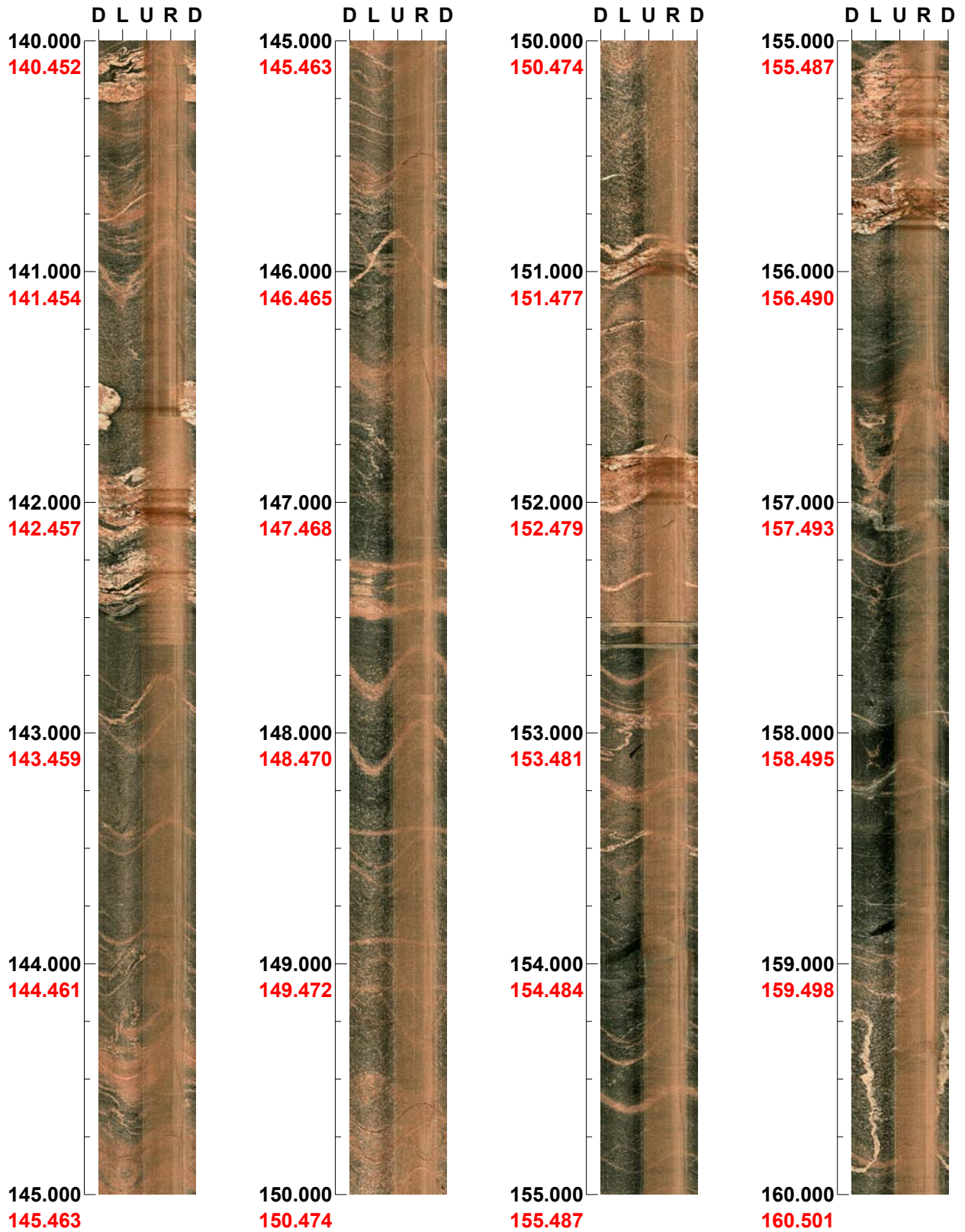

Project name: SFR
Bore hole No.: KFR105

Azimuth: 174 Inclination: -10

Depth range: 160.000 - 180.000 m

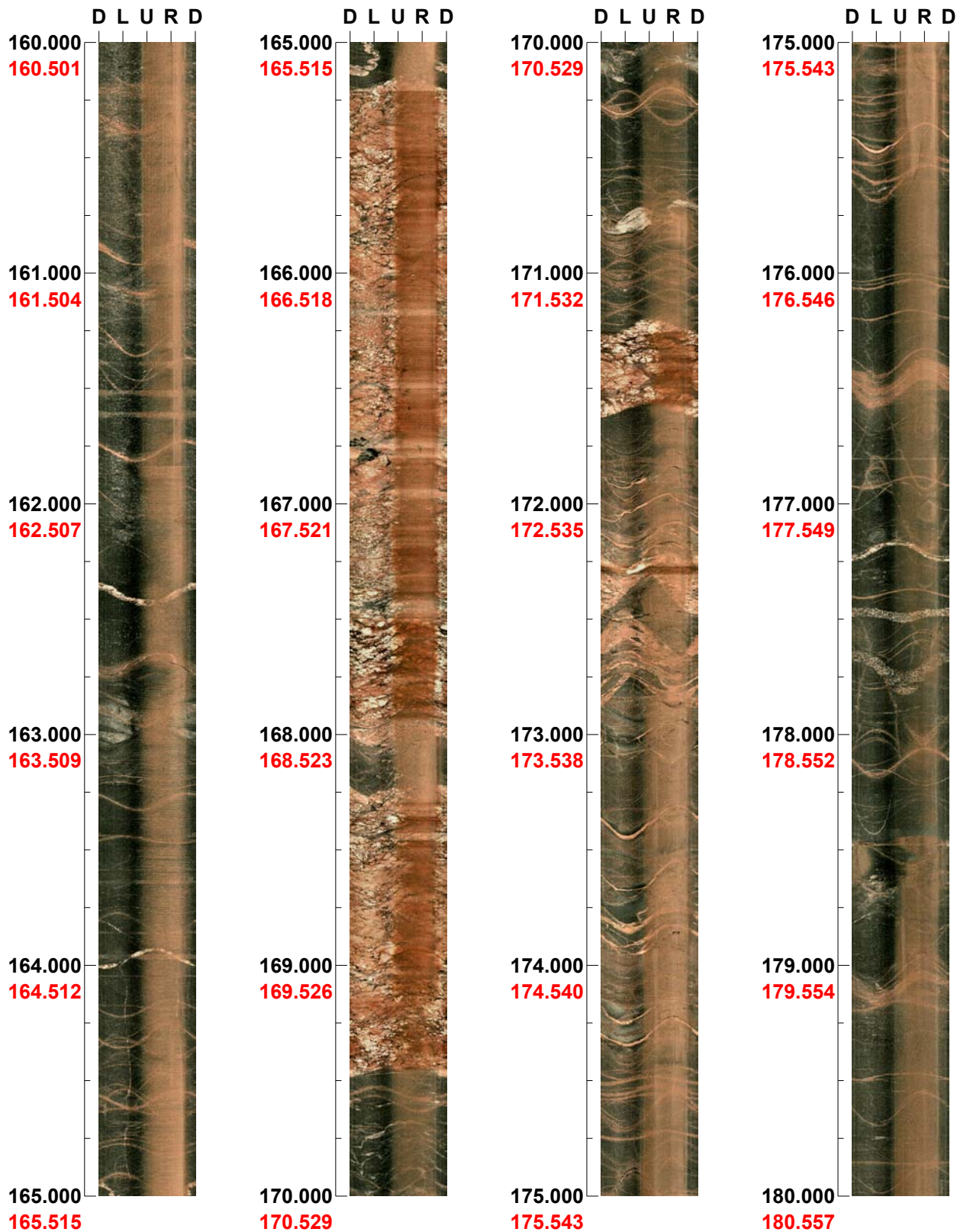

Project name: SFR
Bore hole No.: KFR105

Azimuth: 174 Inclination: -10

Depth range: 180.000 - 200.000 m

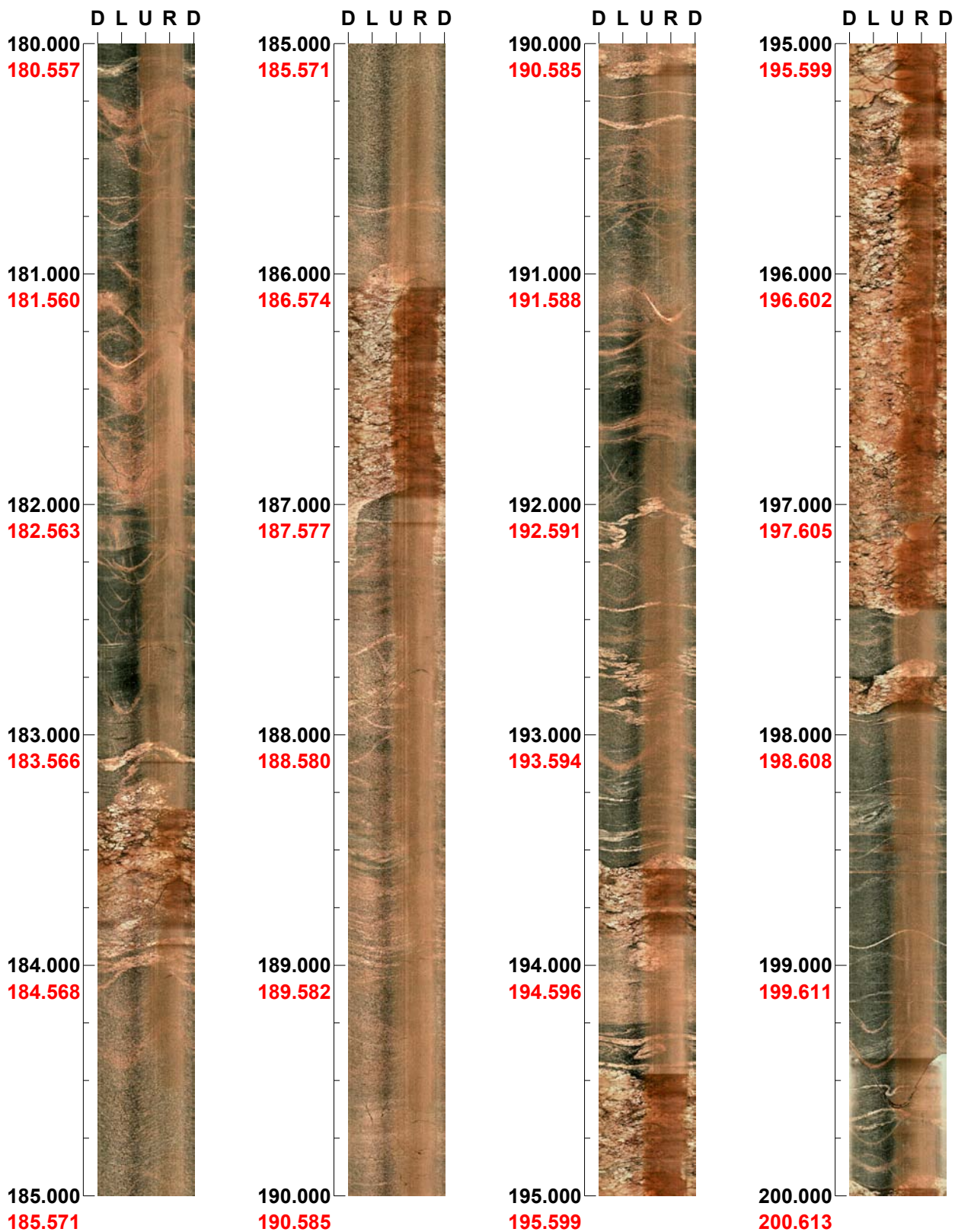

Project name: SFR
Bore hole No.: KFR105

Azimuth: 174 Inclination: -10

Depth range: 200.000 - 220.000 m

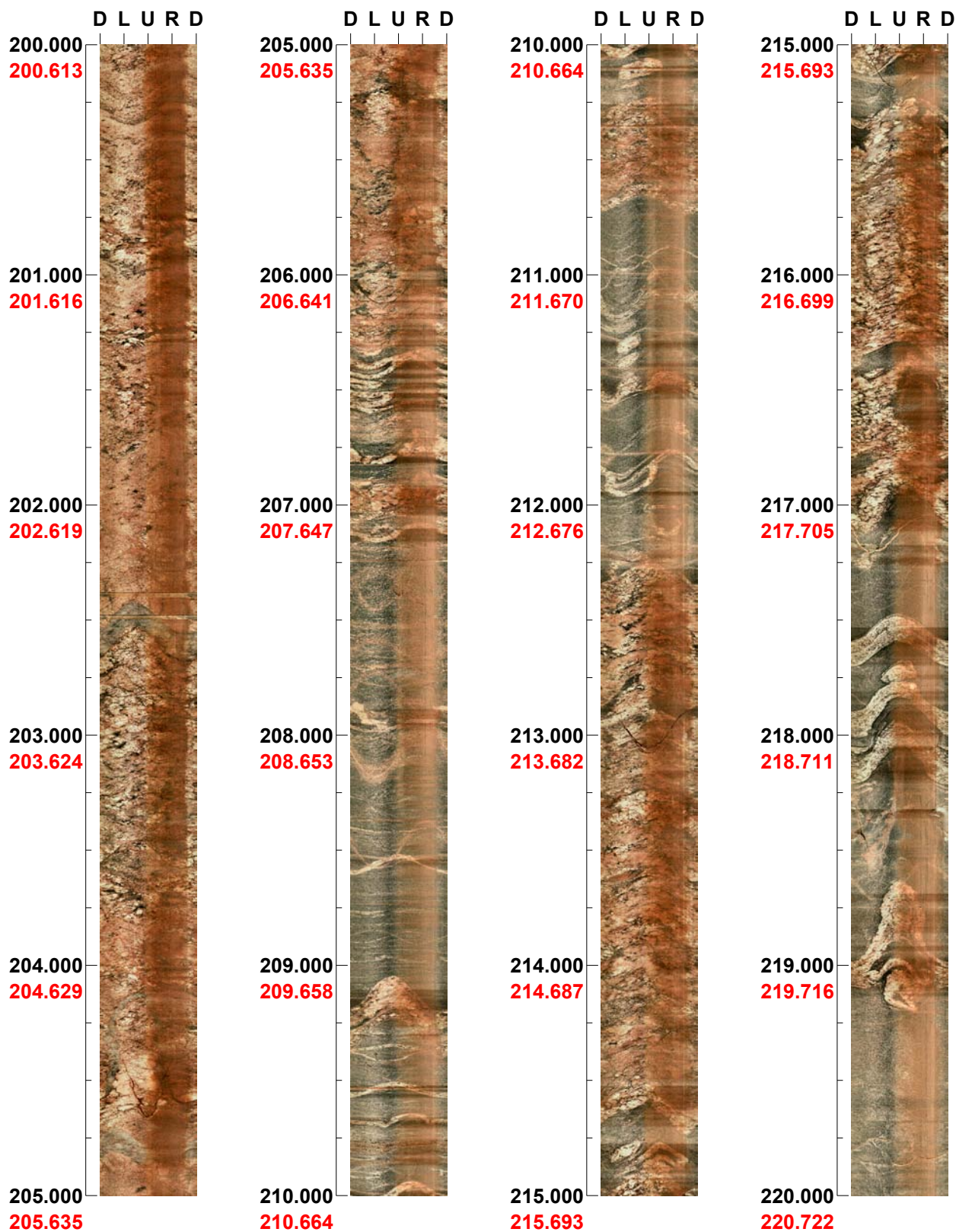

Project name: SFR
Bore hole No.: KFR105

Azimuth: 174 Inclination: -10

Depth range: 220.000 - 240.000 m

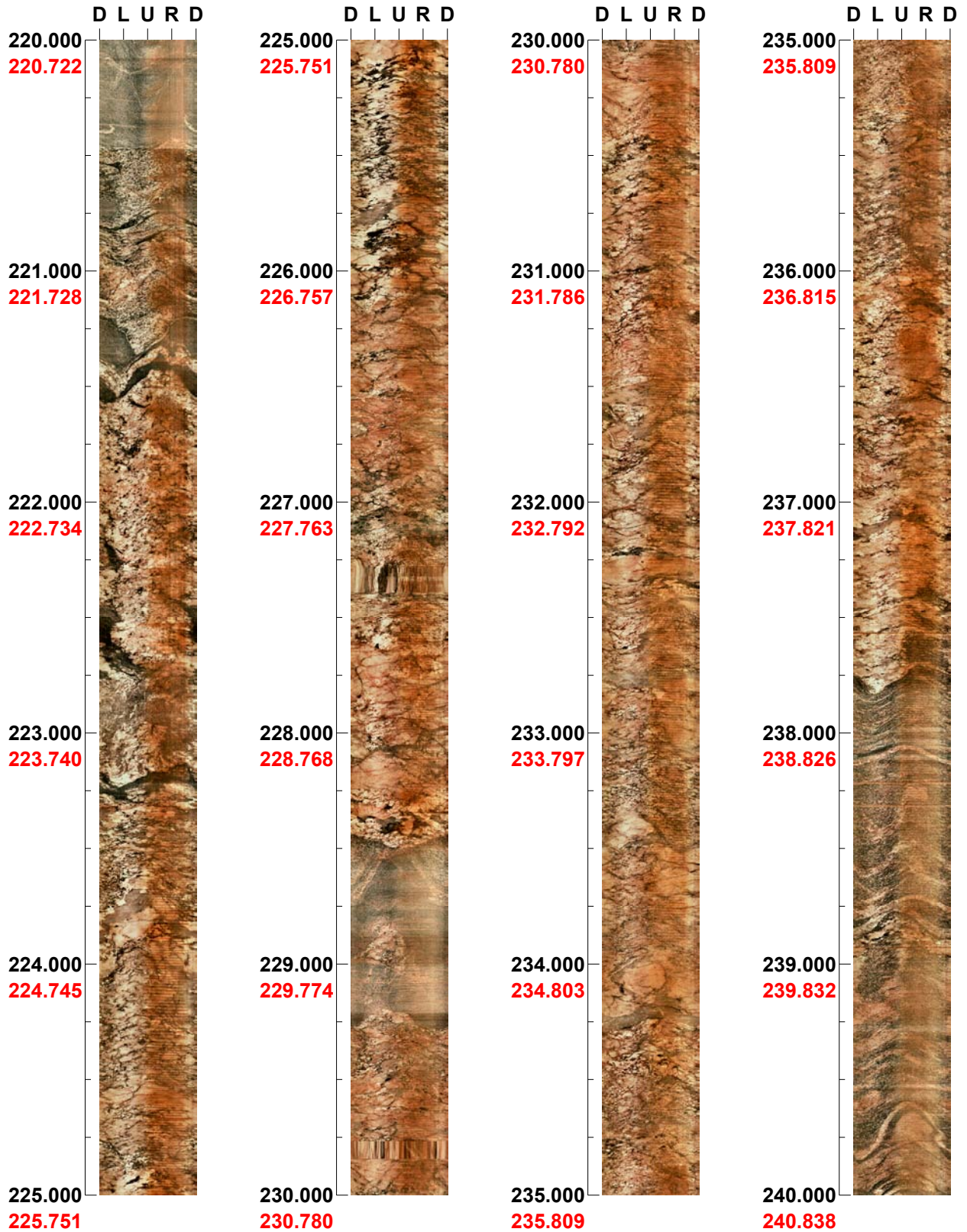

Project name: SFR
Bore hole No.: KFR105

Azimuth: 174 Inclination: -10

Depth range: 240.000 - 260.000 m

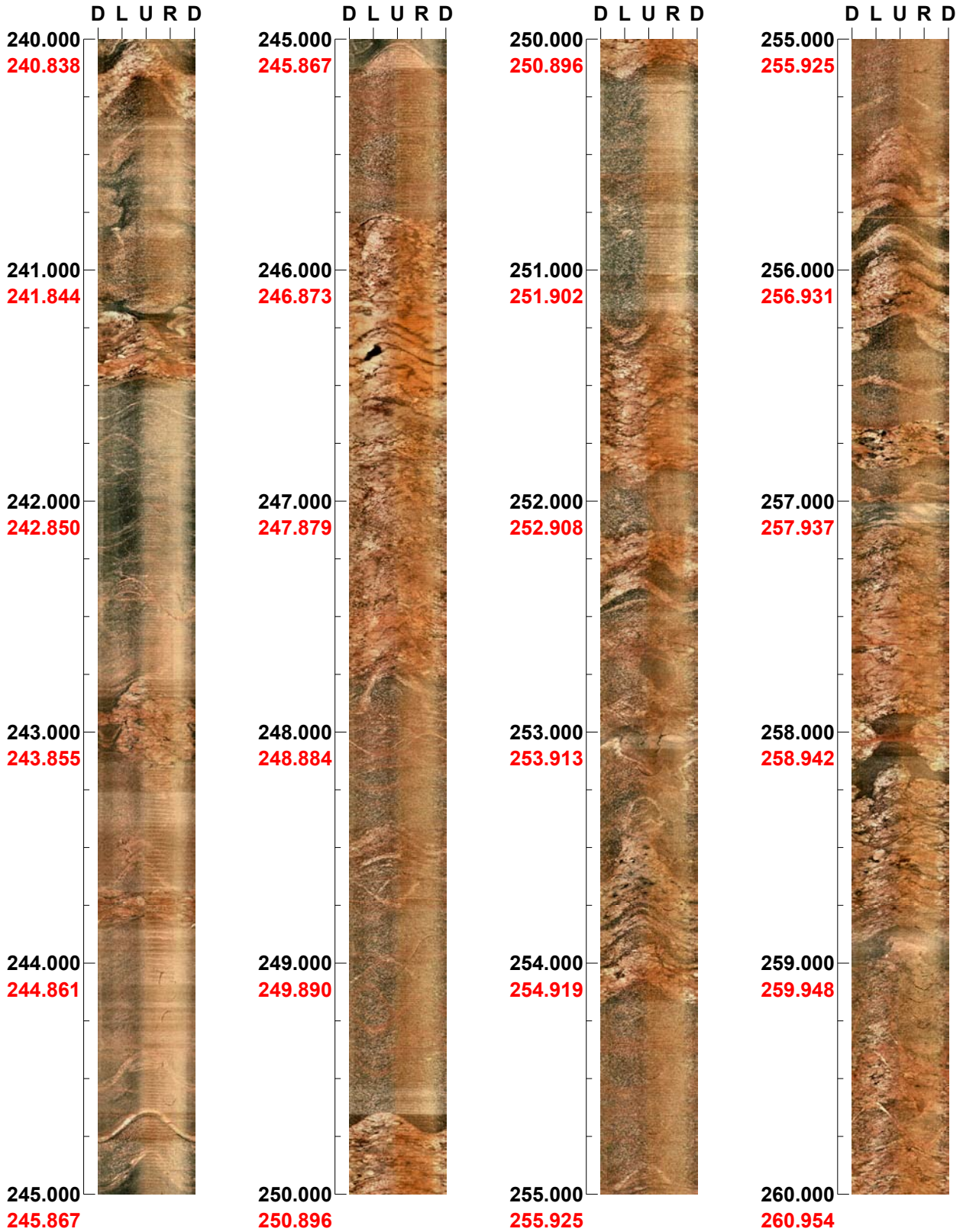

Project name: SFR
Bore hole No.: KFR105

Azimuth: 174

Inclination: -10

Depth range: 260.000 - 280.000 m

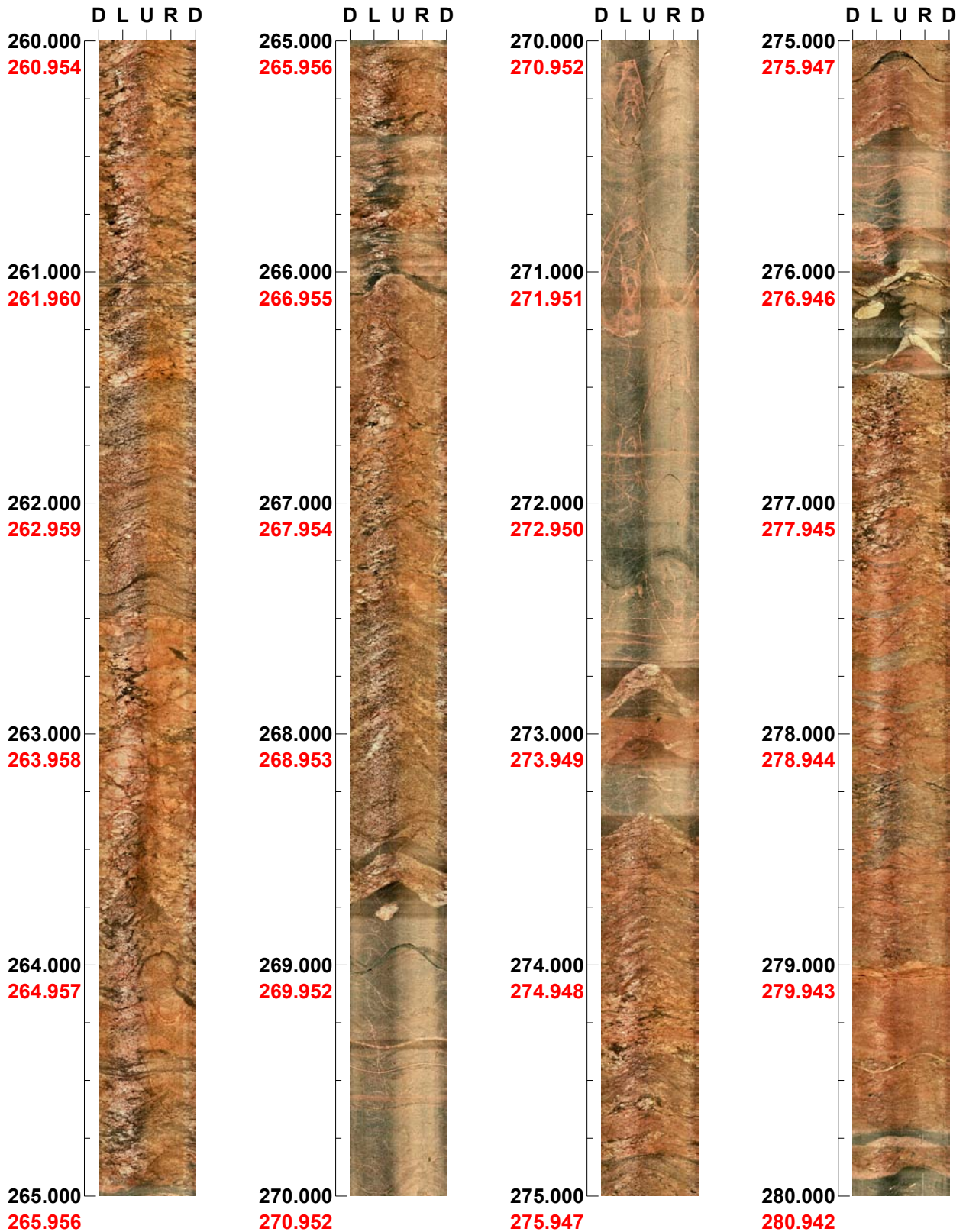

Project name: SFR
Bore hole No.: KFR105

Azimuth: 174

Inclination: -10

Depth range: 280.000 - 300.000 m

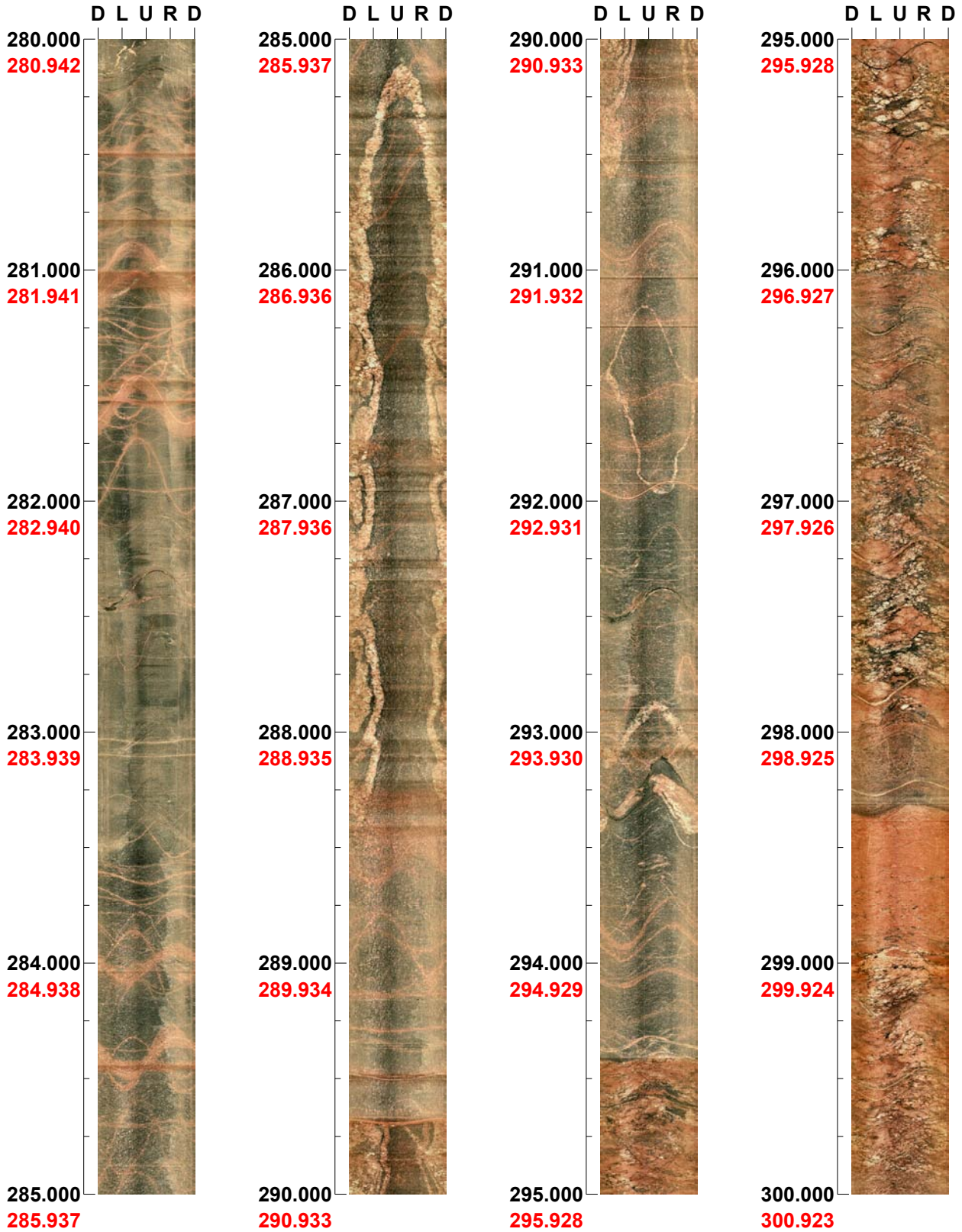

Project name: SFR
Bore hole No.: KFR105

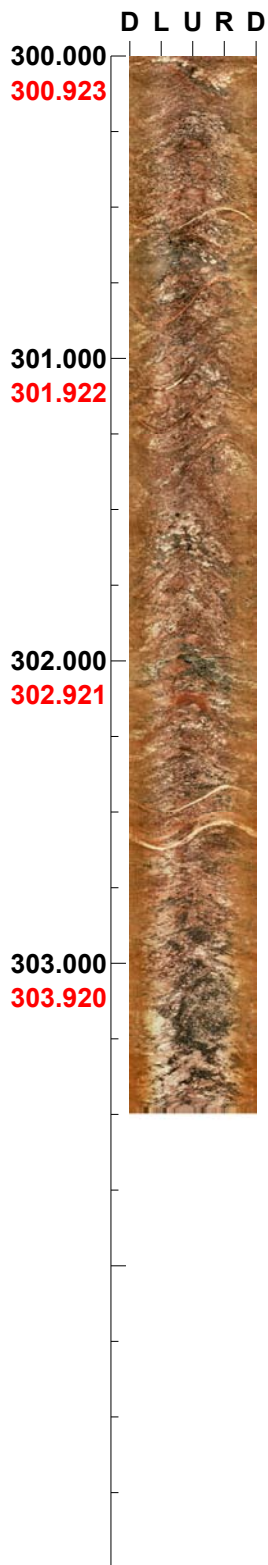

Azimuth: 174 Inclination: -10

Depth range: 300.000 - 303.492 m



BIPS logging in KFR105, repeat section. 290 to 300 m.

Project name: SFR

Image file : c:\temp\bipsda~1\kfr105~1.bip
BDT file :
Locality : SFR
Bore hole number : KFR105
Date : 09/06/16
Time : 15:36:00
Depth range : 289.997 - 300.000 m
Azimuth : 0
Inclination : -90
Diameter : 75.0 mm
Magnetic declination : 0.0
Span : 4
Scan interval : 0.25
Scan direction : To entrance
Scale : 1/25
Aspect ratio : 175 %
Pages : 1
Color :  +0  +0  +0

Project name: SFR
Bore hole No.: KFR105

Azimuth: 0

Inclination: -90

Depth range: 290.000 - 300.000 m



BIPS logging in KFR106. 9 to 297 m.

Project name: SFR

Image file : d:\work\r58xxs~1\bips\kfr106.bip
BDT file : d:\work\r58xxs~1\bips\kfr106.bdt
Locality : SFR
Bore hole number : KFR106
Date : 09/09/21
Time : 15:20:00
Depth range : 9.000 - 297.299 m
Azimuth : 196
Inclination : -69
Diameter : 76.0 mm
Magnetic declination : 0.0
Span : 4
Scan interval : 0.25
Scan direction : To bottom
Scale : 1/25
Aspect ratio : 175 %
Pages : 15
Color : 
 +0 +0 +0

Project name: SFR
Bore hole No.: KFR106

Azimuth: 196 Inclination: -69

Depth range: 0.000 - 20.000 m

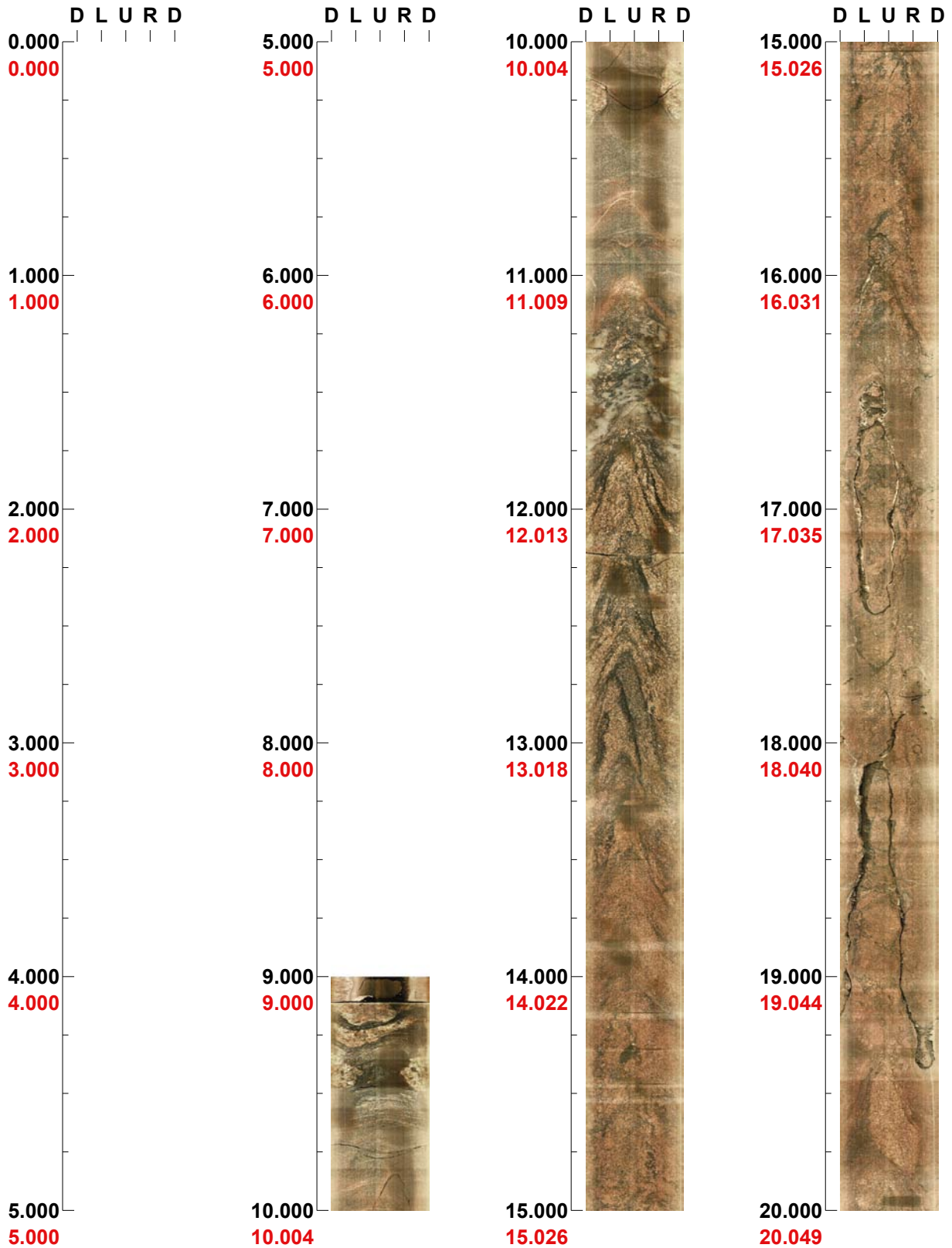

Project name: SFR
Bore hole No.: KFR106

Azimuth: 196

Inclination: -69

Depth range: 20.000 - 40.000 m

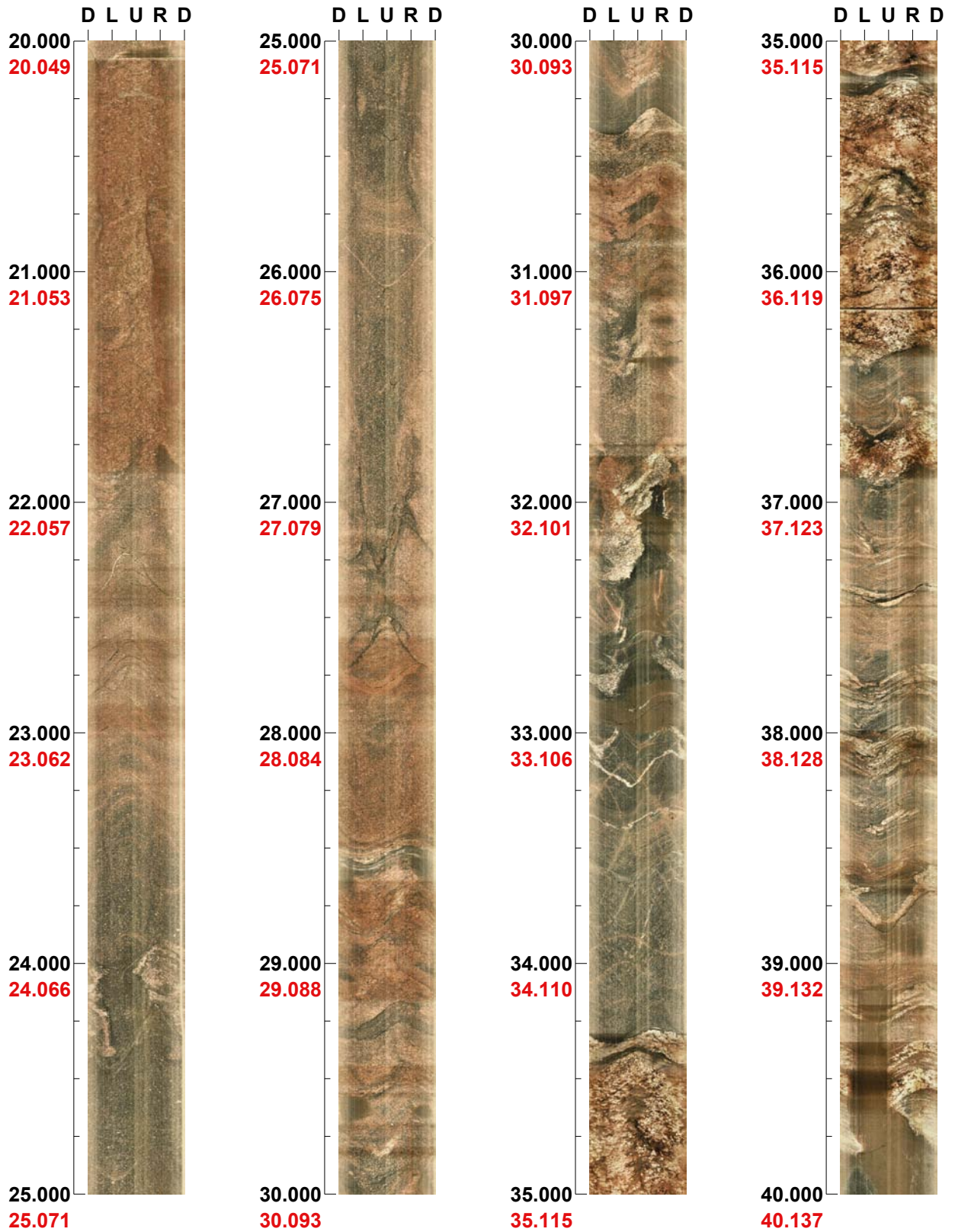

Project name: SFR
Bore hole No.: KFR106

Azimuth: 196

Inclination: -69

Depth range: 40.000 - 60.000 m

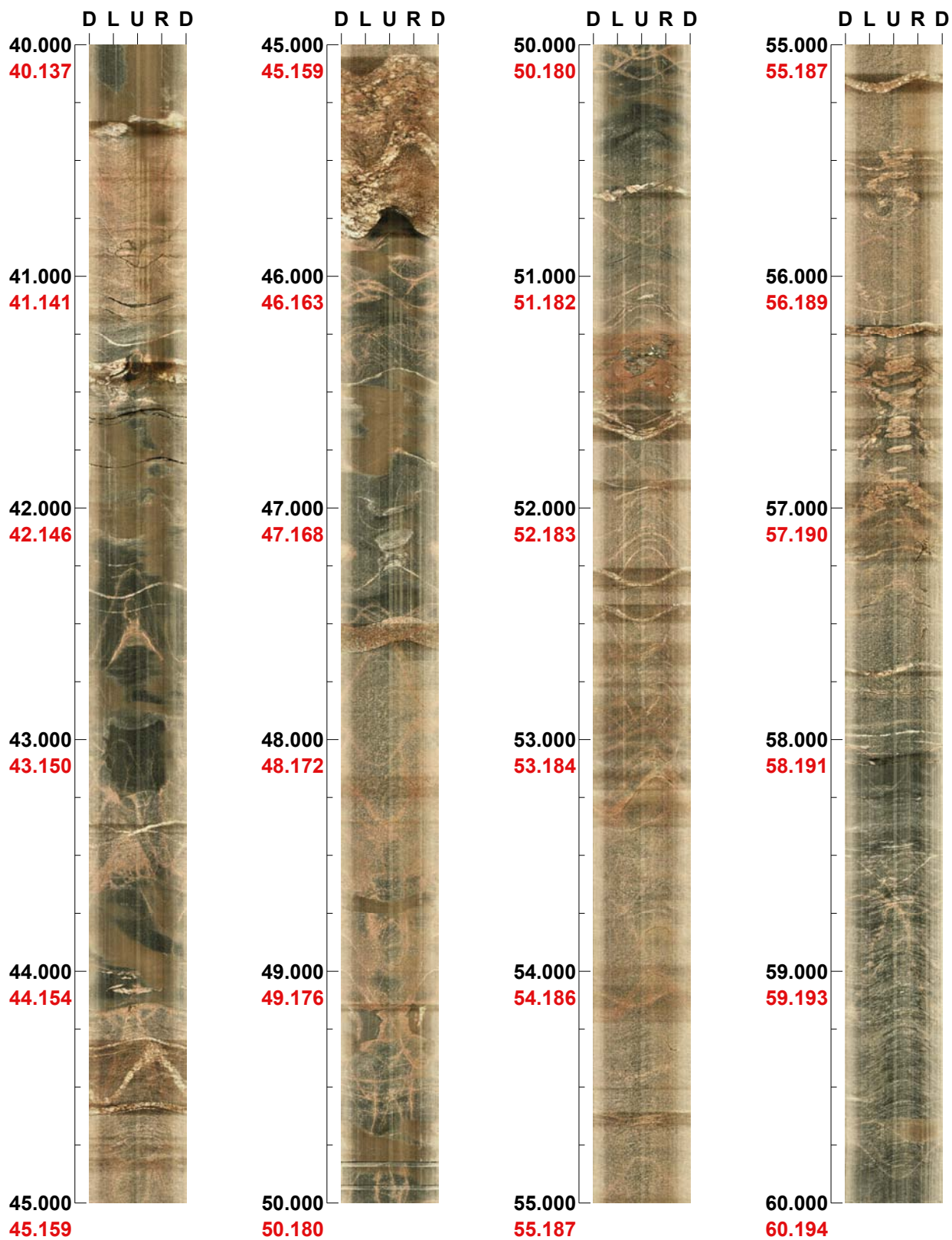

Project name: SFR
Bore hole No.: KFR106

Azimuth: 196 Inclination: -69

Depth range: 60.000 - 80.000 m

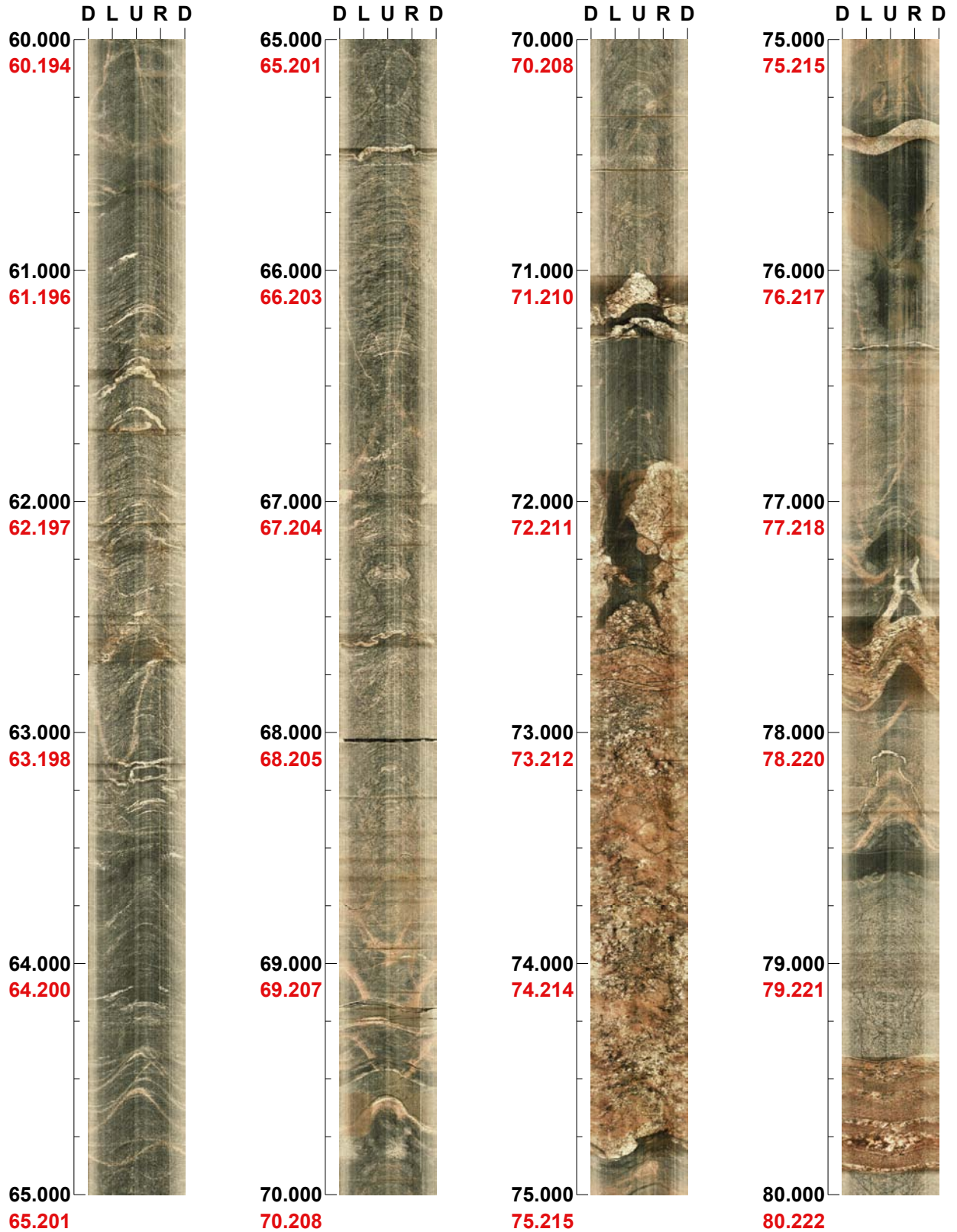

Project name: SFR
Bore hole No.: KFR106

Azimuth: 196

Inclination: -69

Depth range: 80.000 - 100.000 m

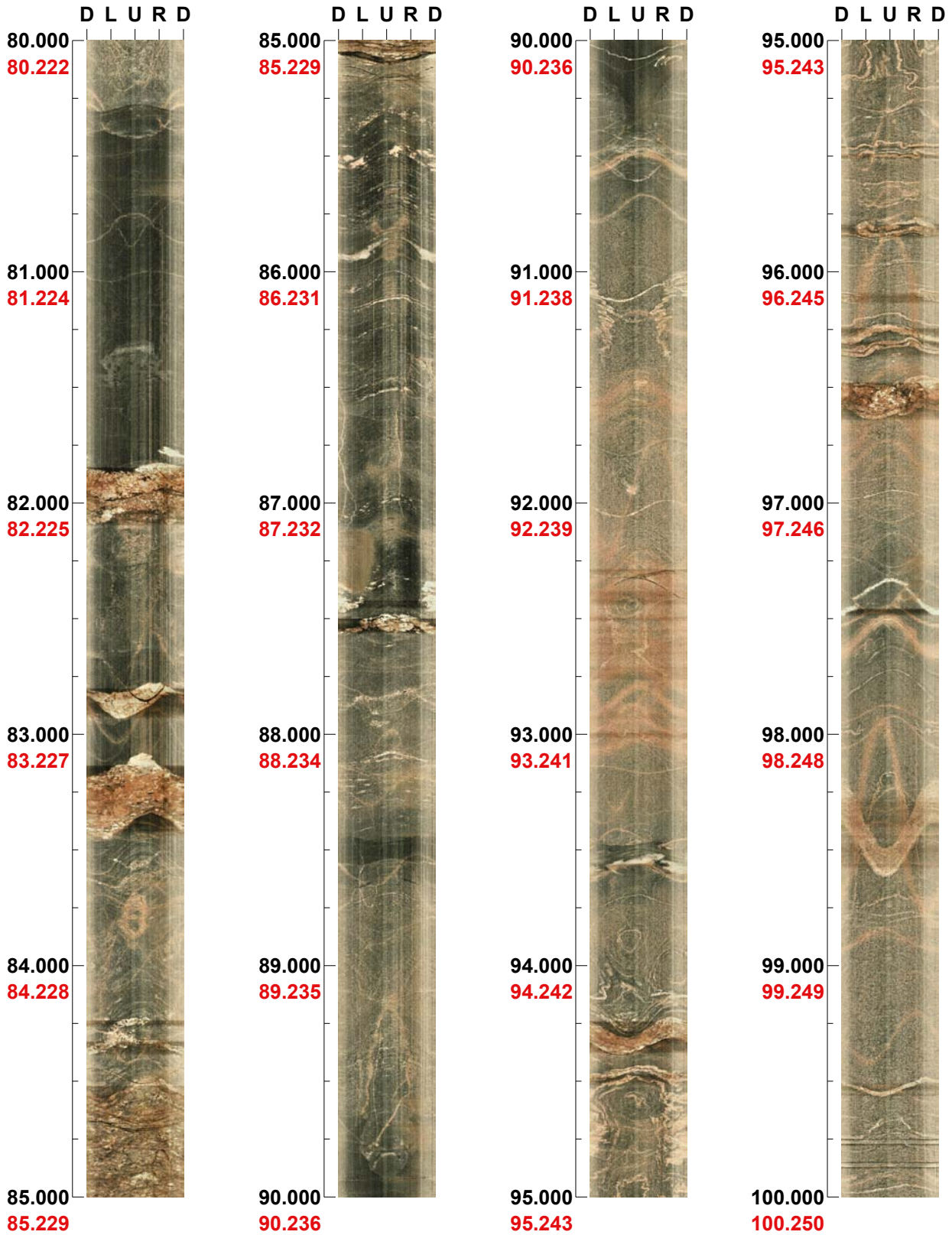

Project name: SFR
Bore hole No.: KFR106

Azimuth: 196

Inclination: -69

Depth range: 100.000 - 120.000 m

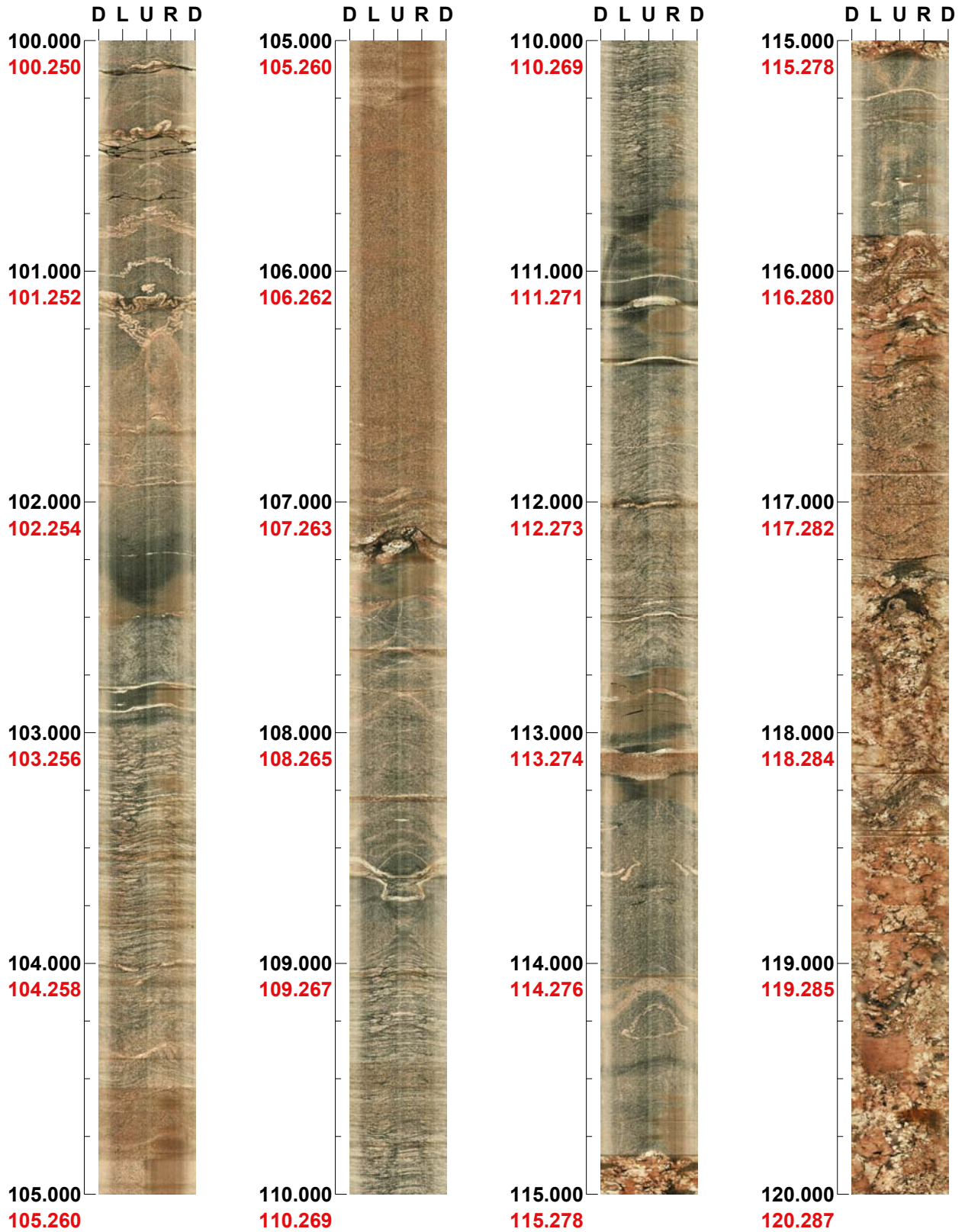

Project name: SFR
Bore hole No.: KFR106

Azimuth: 196 Inclination: -69

Depth range: 120.000 - 140.000 m

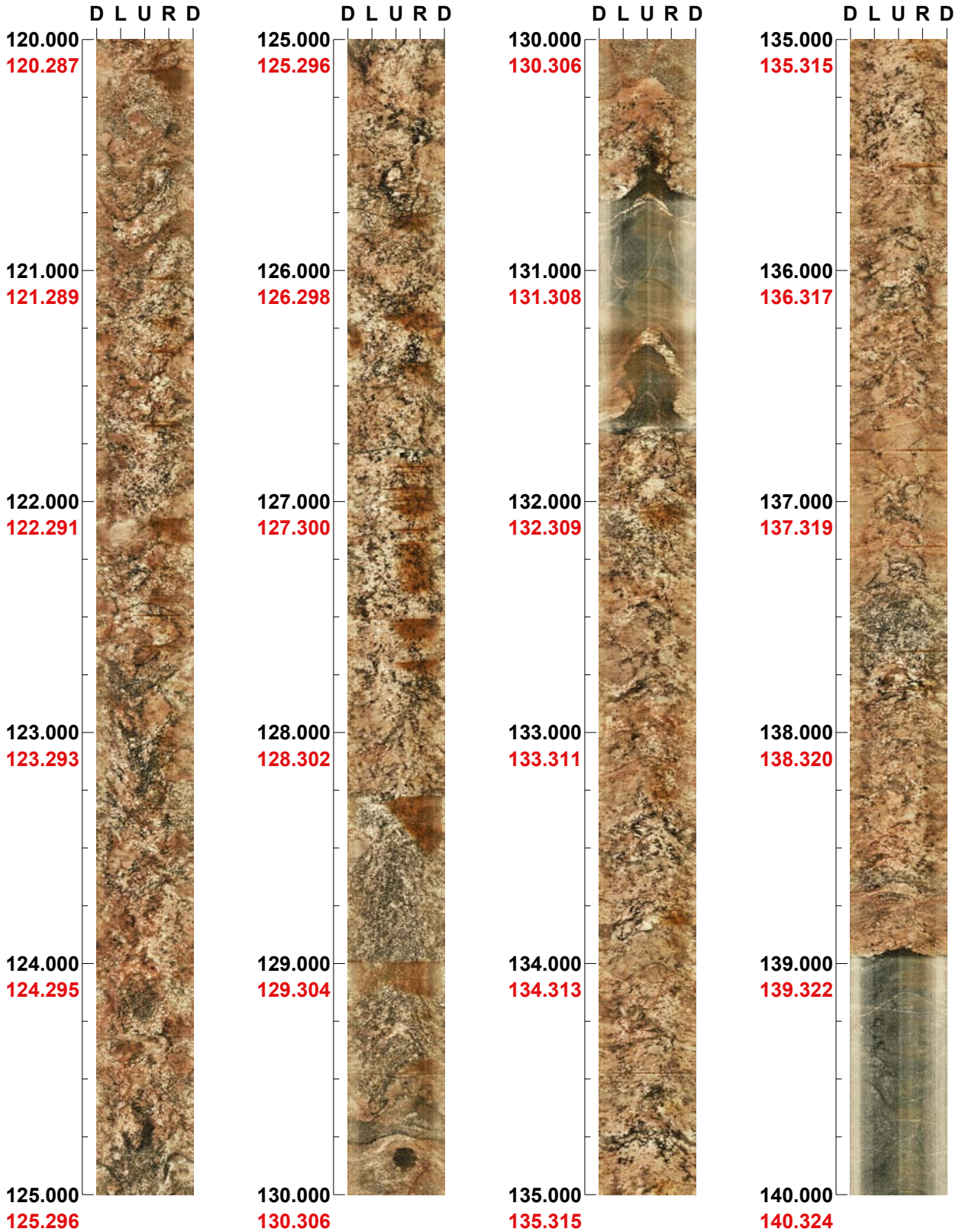

Project name: SFR
Bore hole No.: KFR106

Azimuth: 196 Inclination: -69

Depth range: 140.000 - 160.000 m

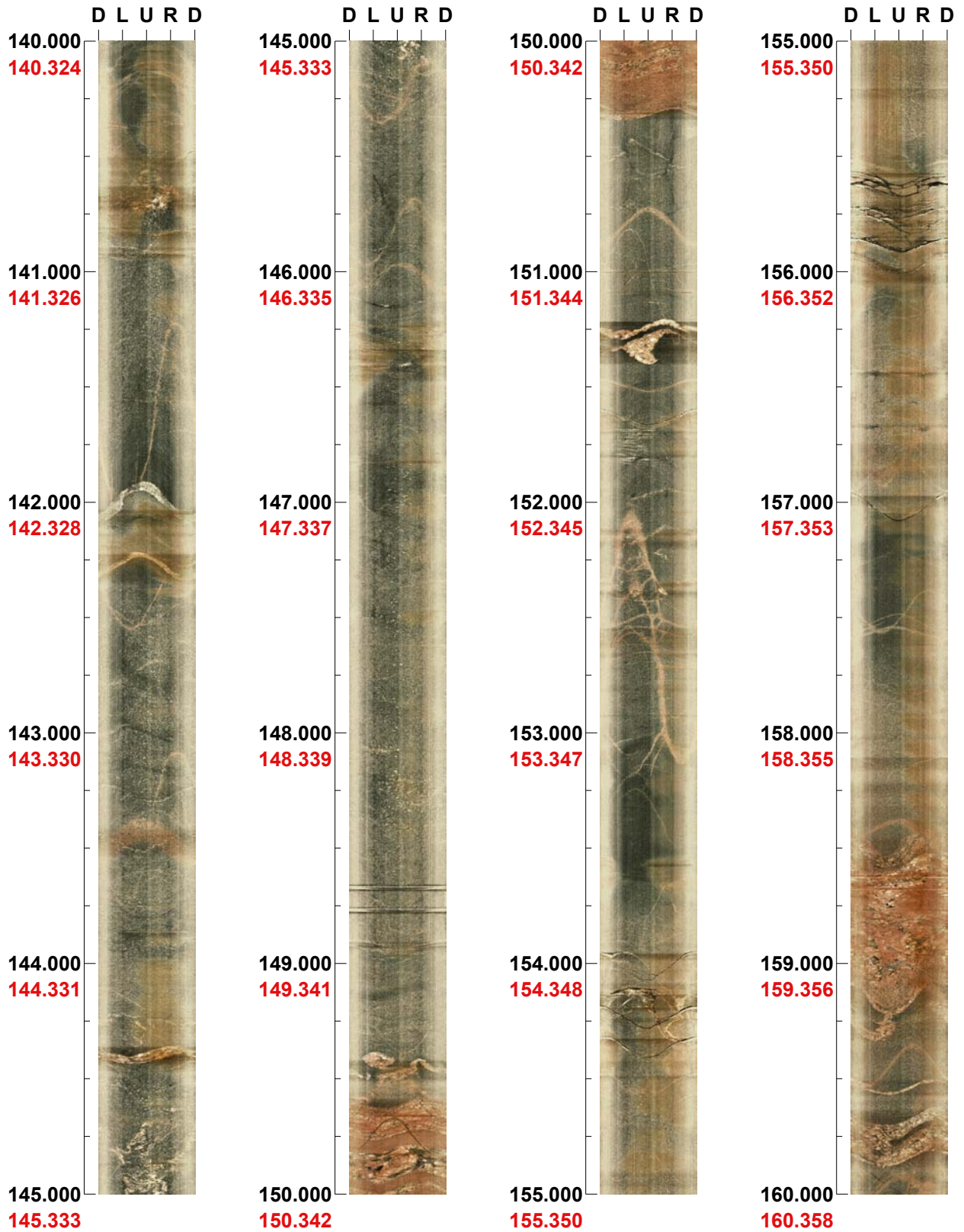

Project name: SFR
Bore hole No.: KFR106

Azimuth: 196 Inclination: -69

Depth range: 160.000 - 180.000 m

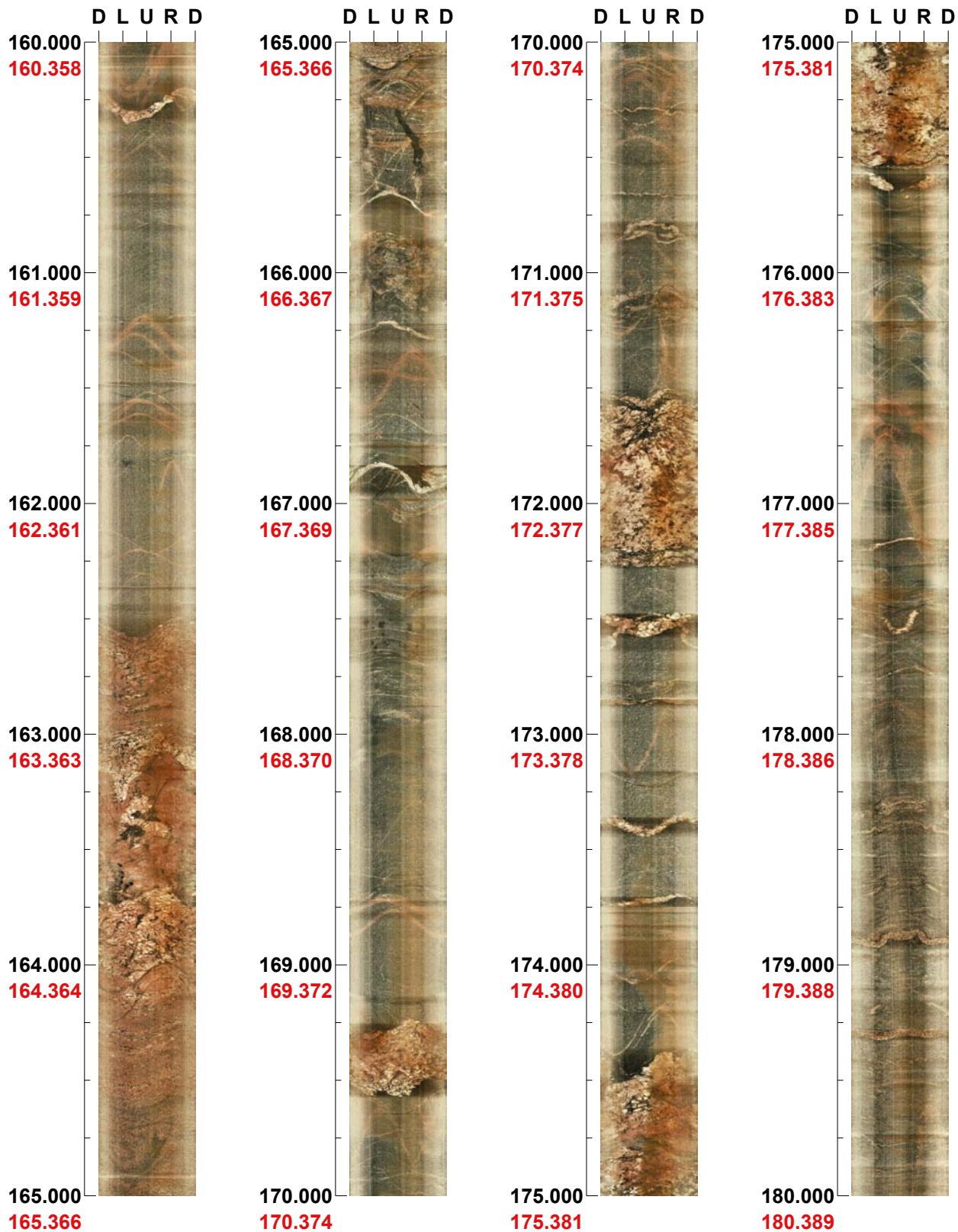

Project name: SFR
Bore hole No.: KFR106

Azimuth: 196

Inclination: -69

Depth range: 180.000 - 200.000 m

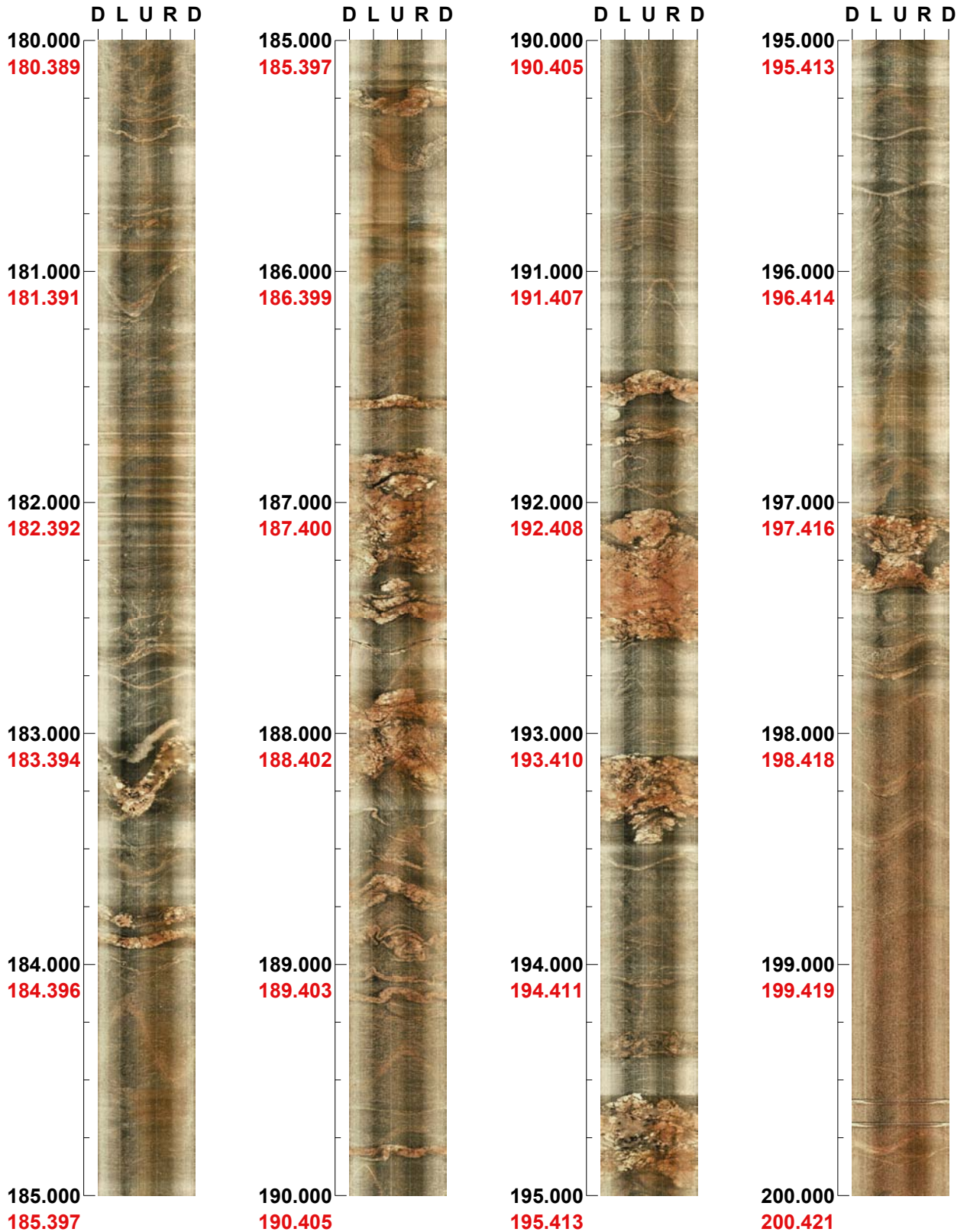

Project name: SFR
Bore hole No.: KFR106

Azimuth: 196 Inclination: -69

Depth range: 200.000 - 220.000 m



Project name: SFR
Bore hole No.: KFR106

Azimuth: 196 Inclination: -69

Depth range: 220.000 - 240.000 m



Project name: SFR
Bore hole No.: KFR106

Azimuth: 196 Inclination: -69

Depth range: 240.000 - 260.000 m

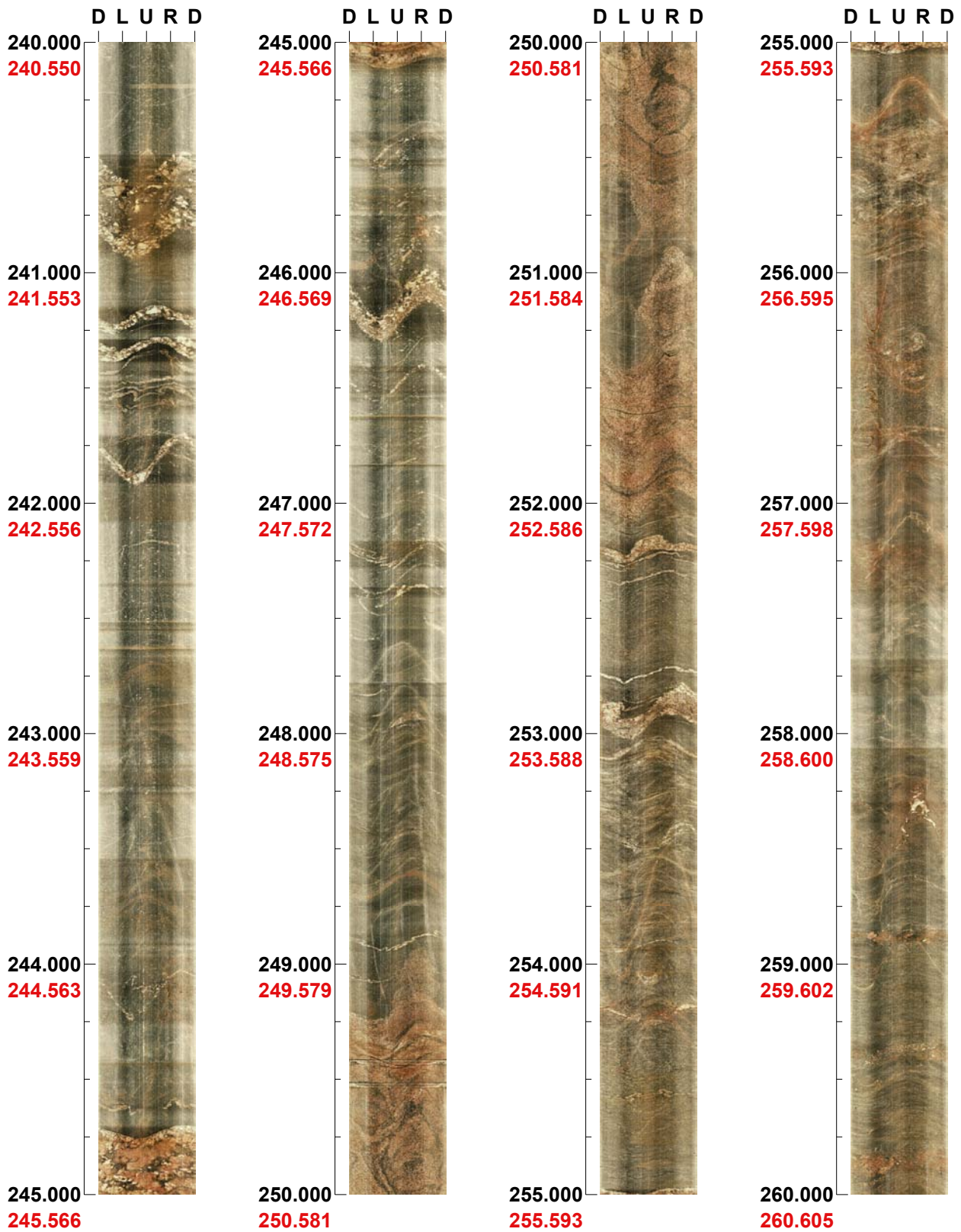

Project name: SFR
Bore hole No.: KFR106

Azimuth: 196 Inclination: -69

Depth range: 260.000 - 280.000 m



Project name: SFR
Bore hole No.: KFR106

Azimuth: 196 Inclination: -69

Depth range: 280.000 - 297.299 m

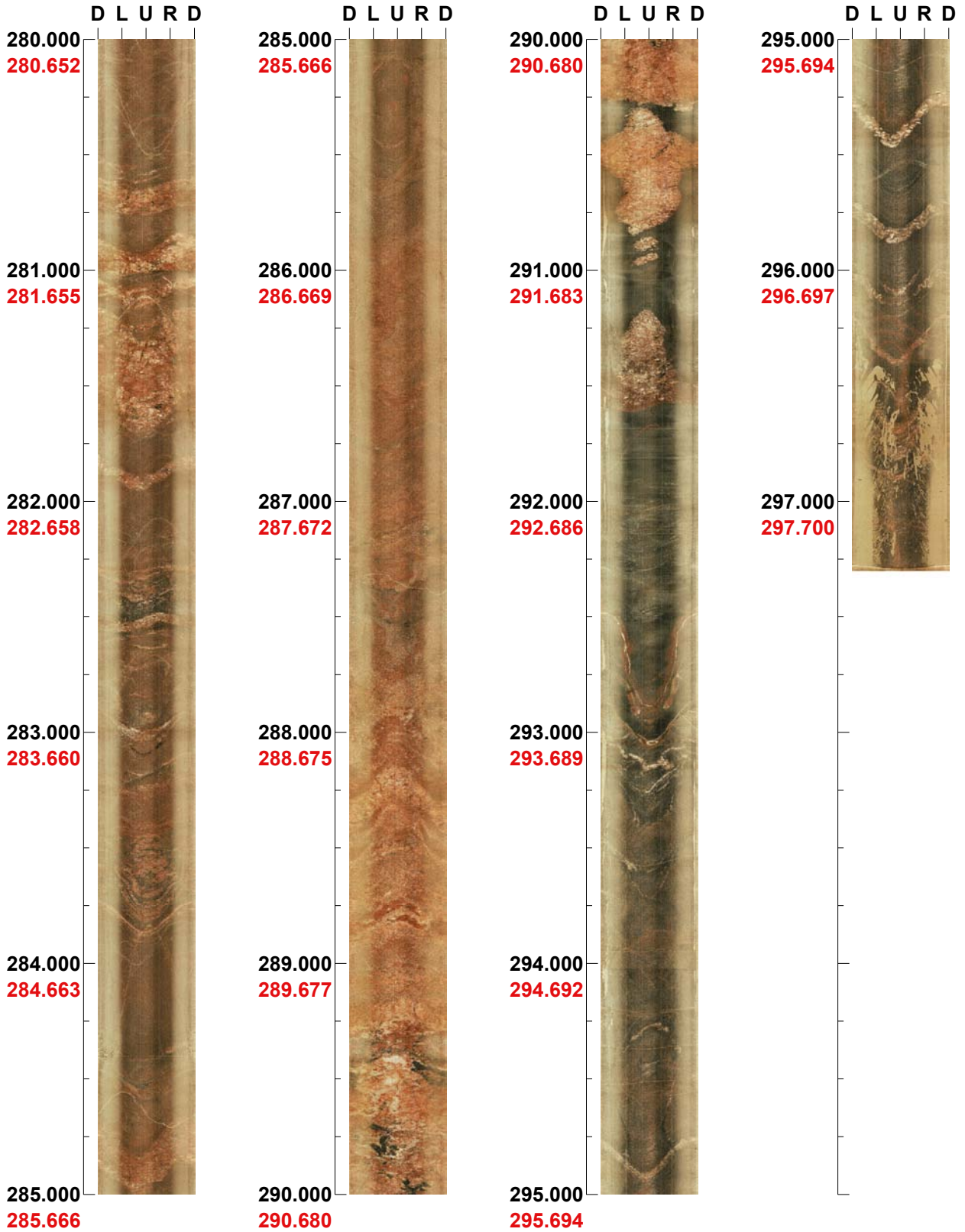

BIPS logging in KFR106, repeat section. 9 to 20 m.

Project name: SFR

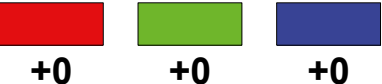
Image file : d:\work\r58xxs~1\bips\kfr106~1.bip
BDT file :
Locality : SFR
Bore hole number : KFR106
Date : 09/09/23
Time : 09:08:00
Depth range : 9.000 - 20.002 m
Azimuth : 0
Inclination : -90
Diameter : 76.0 mm
Magnetic declination : 0.0
Span : 4
Scan interval : 0.25
Scan direction : To bottom
Scale : 1/25
Aspect ratio : 175 %
Pages : 2
Color : 

Project name: SFR
Bore hole No.: KFR106

Azimuth: 0

Inclination: -90

Depth range: 0.000 - 20.000 m

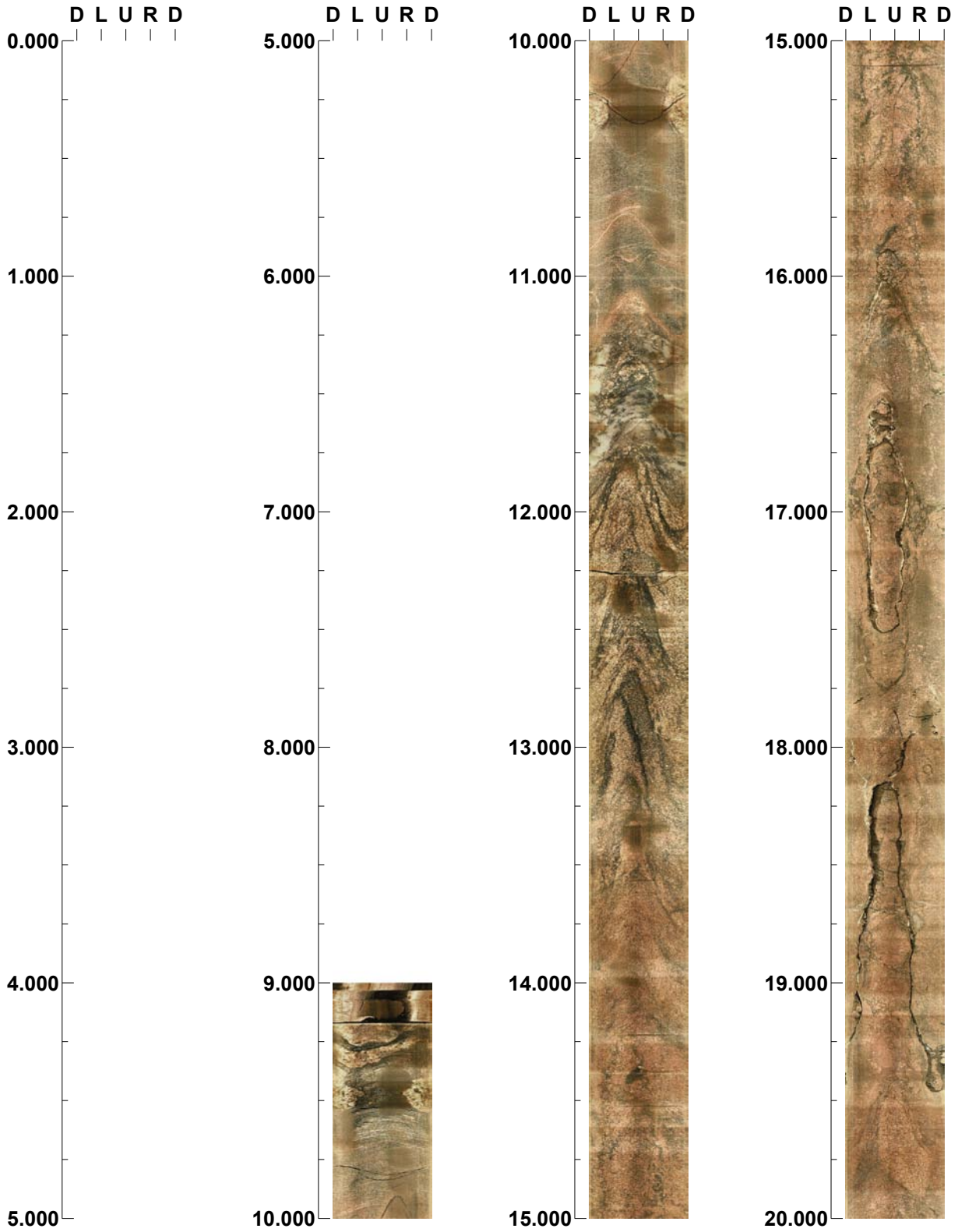

BIPS logging in HFR106. 9 to 189 m.

Project name: SFR

Image file : d:\work\r58xxs~1\bips\hfr106.bip
BDT file : d:\work\r58xxs~1\bips\hfr106.bdt
Locality : SFR
Bore hole number : HFR106
Date : 09/09/23
Time : 11:45:00
Depth range : 9.000 - 189.136 m
Azimuth : 0
Inclination : -90
Diameter : 140.0 mm
Magnetic declination : 0.0
Span : 4
Scan interval : 0.25
Scan direction : To bottom
Scale : 1/25
Aspect ratio : 90 %
Pages : 10
Color : 

Project name: SFR
Bore hole No.: HFR106

Azimuth: 0

Inclination: -90

Depth range: 0.000 - 20.000 m

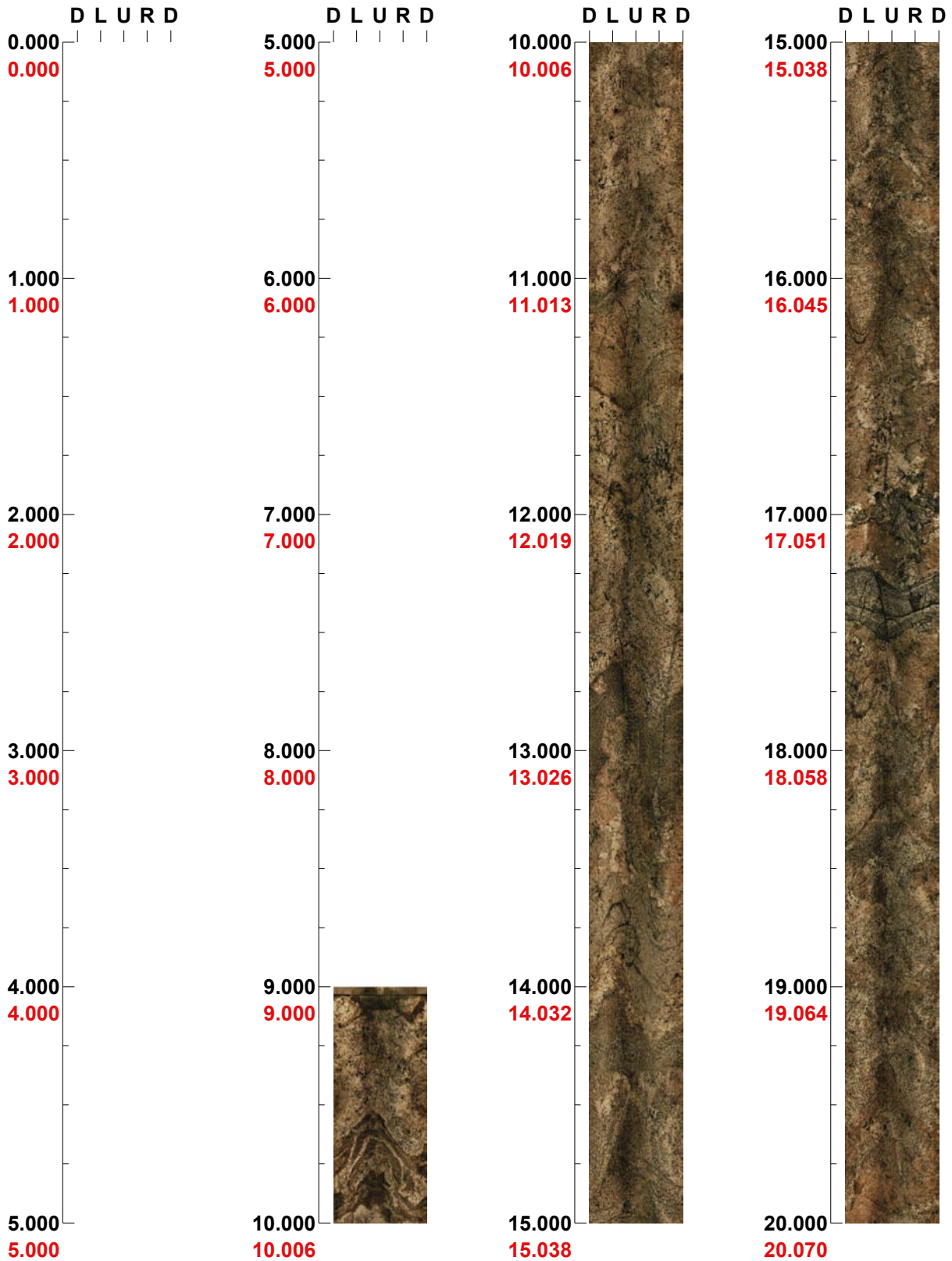

Project name: SFR
Bore hole No.: HFR106

Azimuth: 0

Inclination: -90

Depth range: 20.000 - 40.000 m

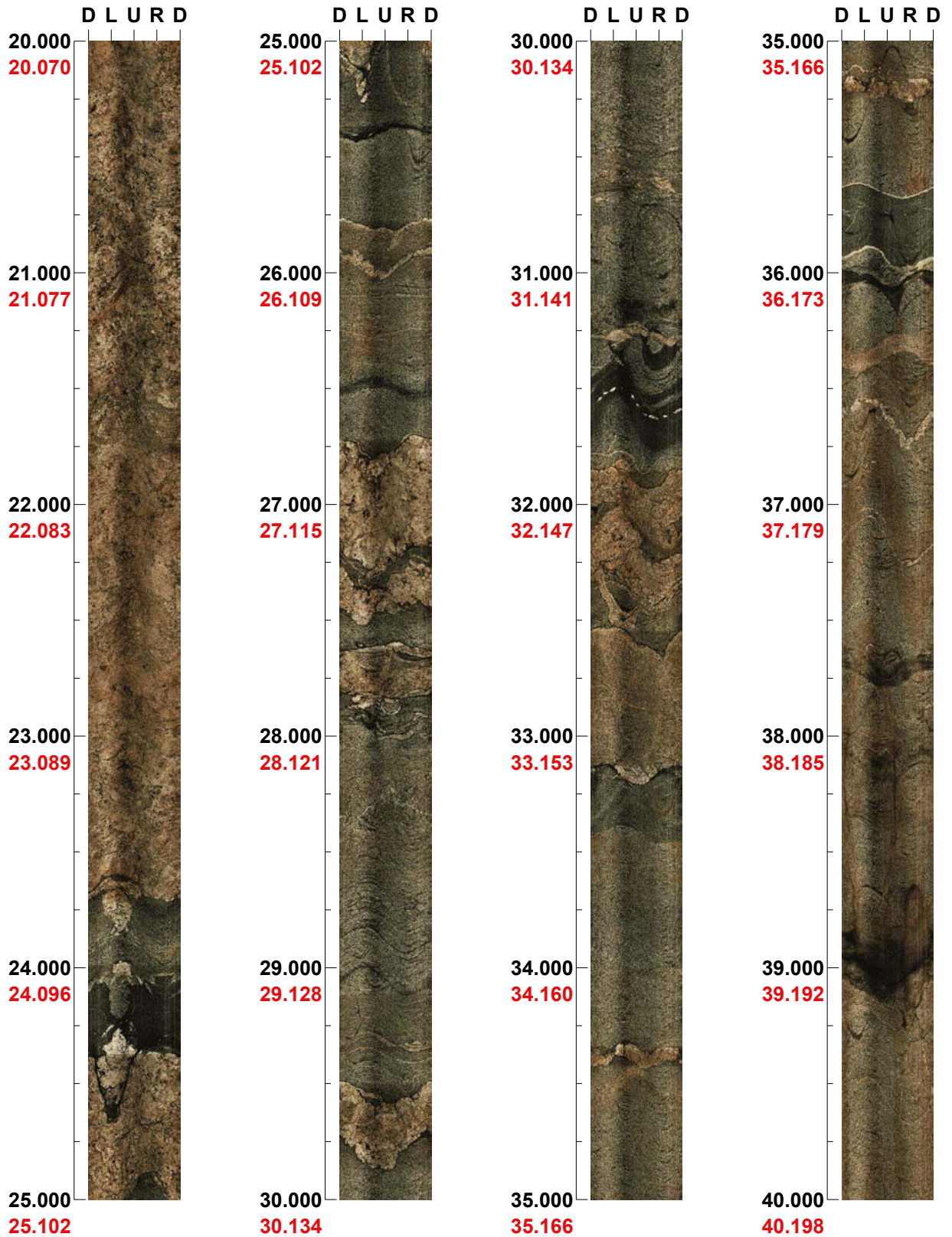

Project name: SFR
Bore hole No.: HFR106

Azimuth: 0

Inclination: -90

Depth range: 40.000 - 60.000 m

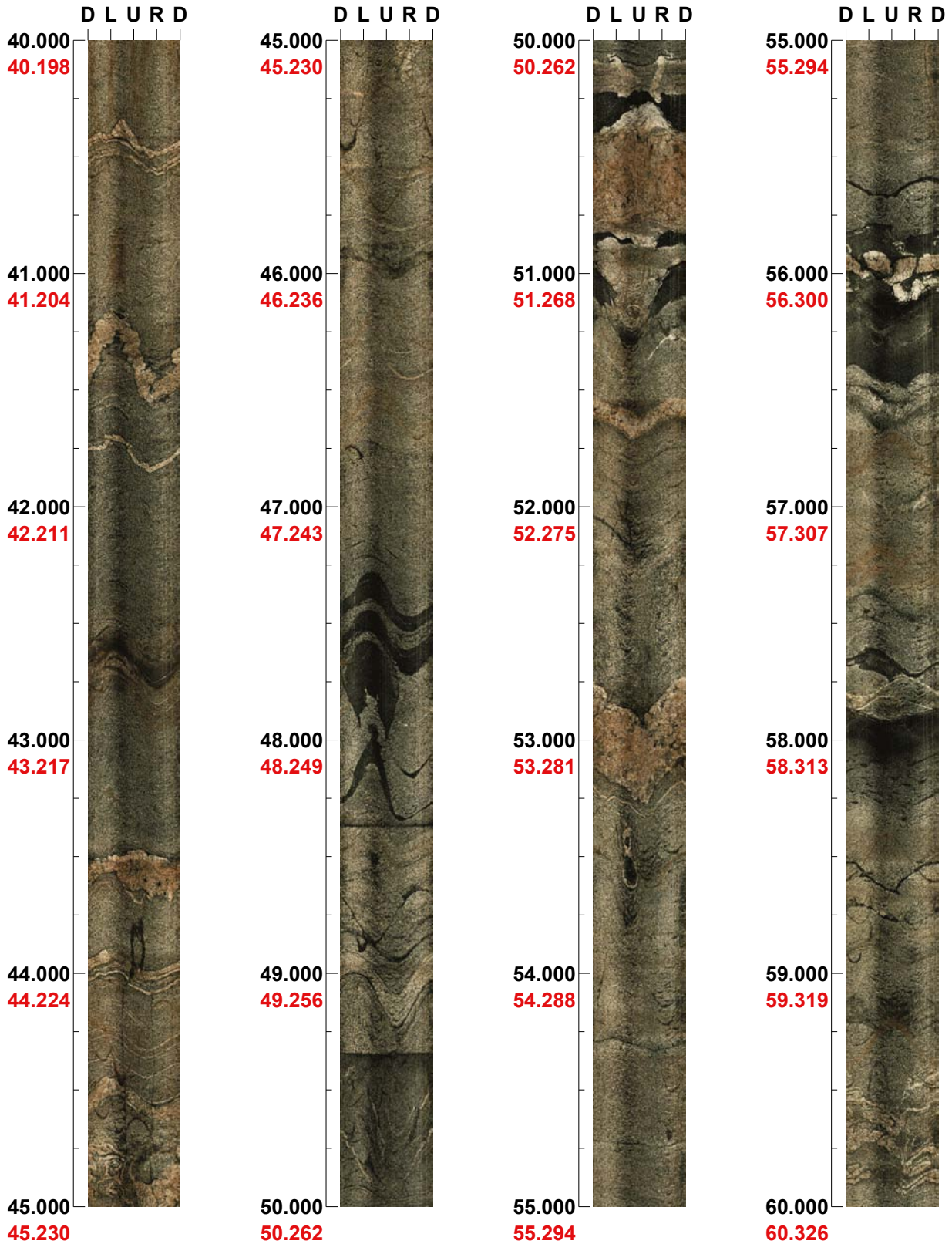

Project name: SFR
Bore hole No.: HFR106

Azimuth: 0

Inclination: -90

Depth range: 60.000 - 80.000 m

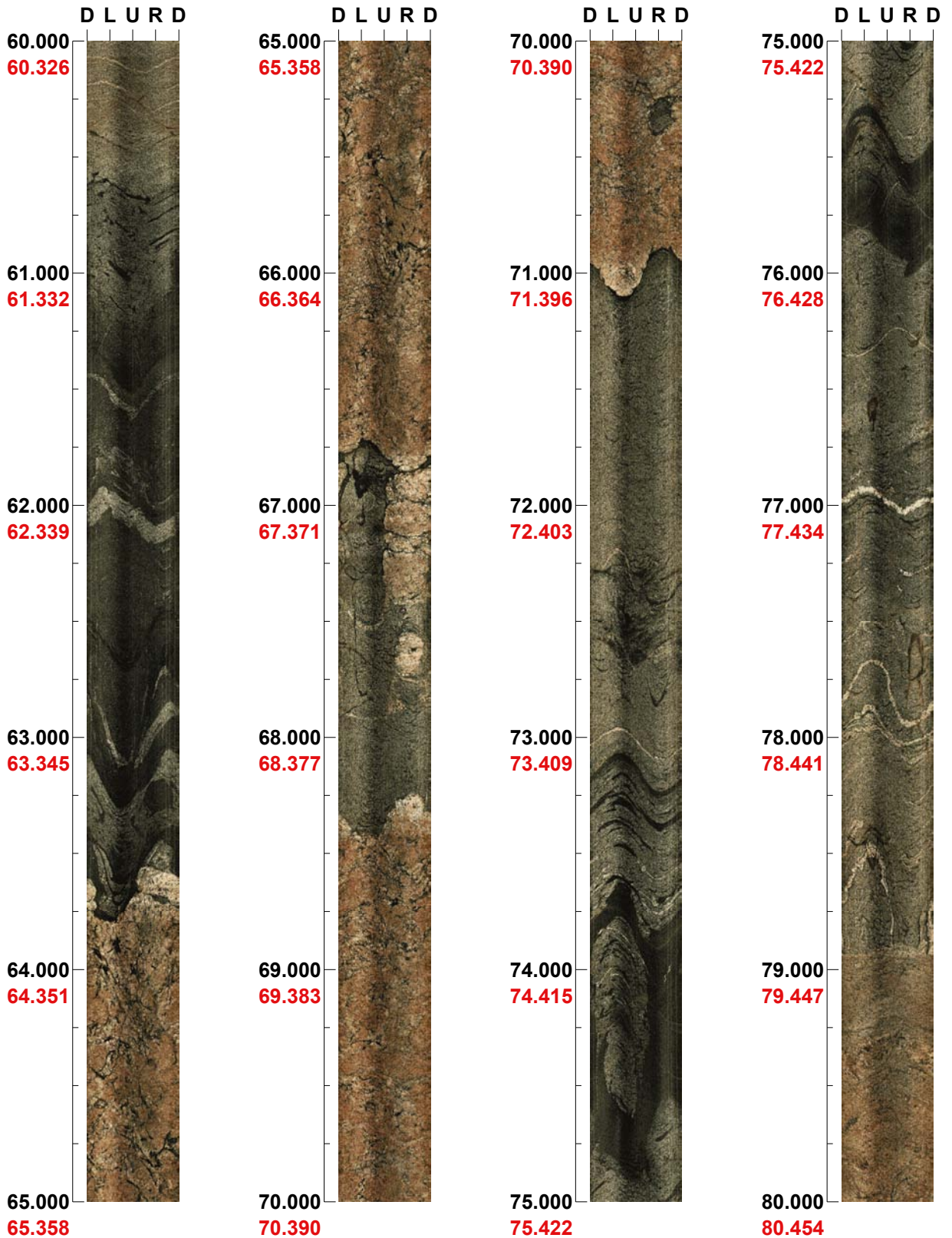

Project name: SFR
Bore hole No.: HFR106

Azimuth: 0

Inclination: -90

Depth range: 80.000 - 100.000 m



Project name: SFR
Bore hole No.: HFR106

Azimuth: 0

Inclination: -90

Depth range: 100.000 - 120.000 m

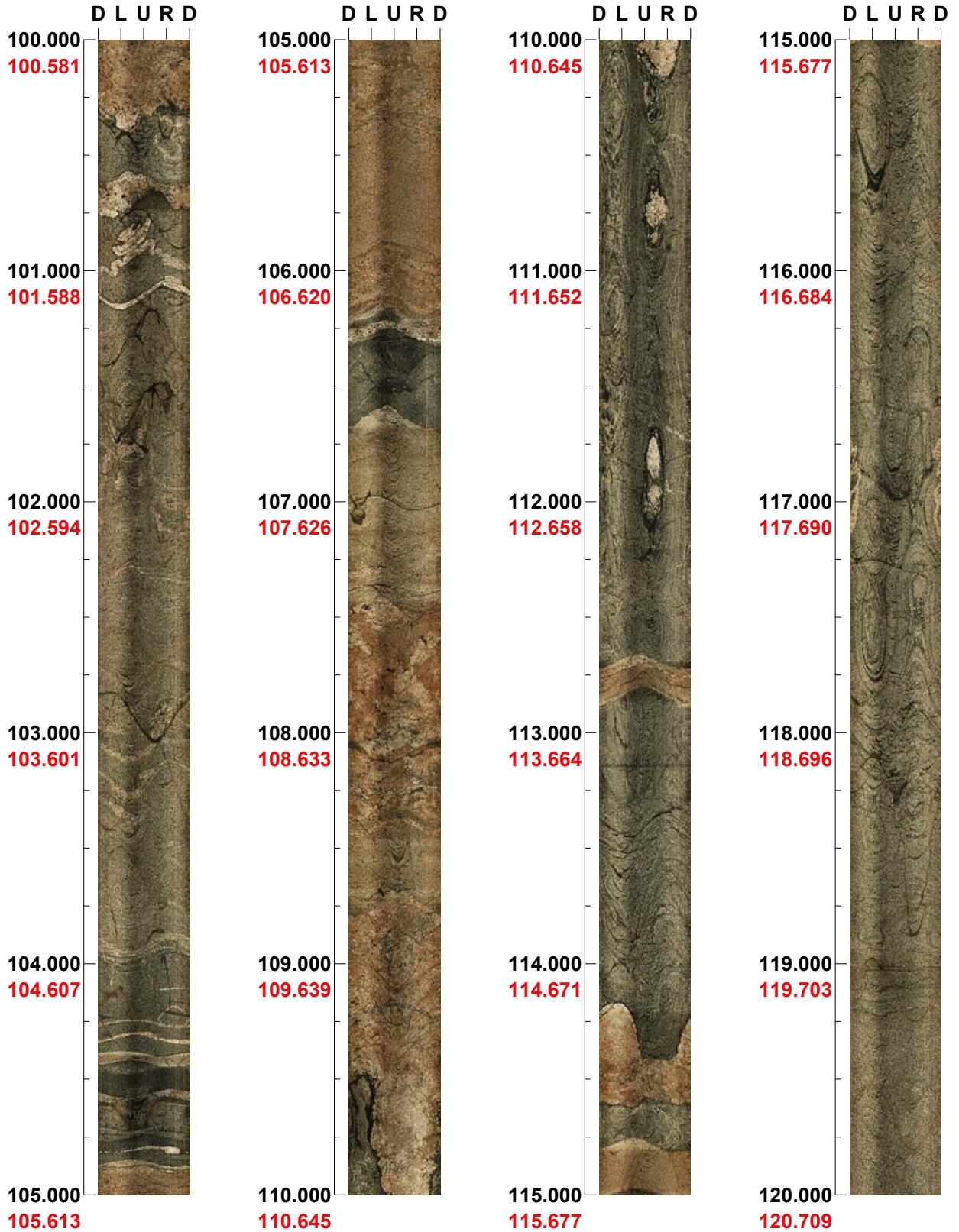

Project name: SFR
Bore hole No.: HFR106

Azimuth: 0

Inclination: -90

Depth range: 120.000 - 140.000 m

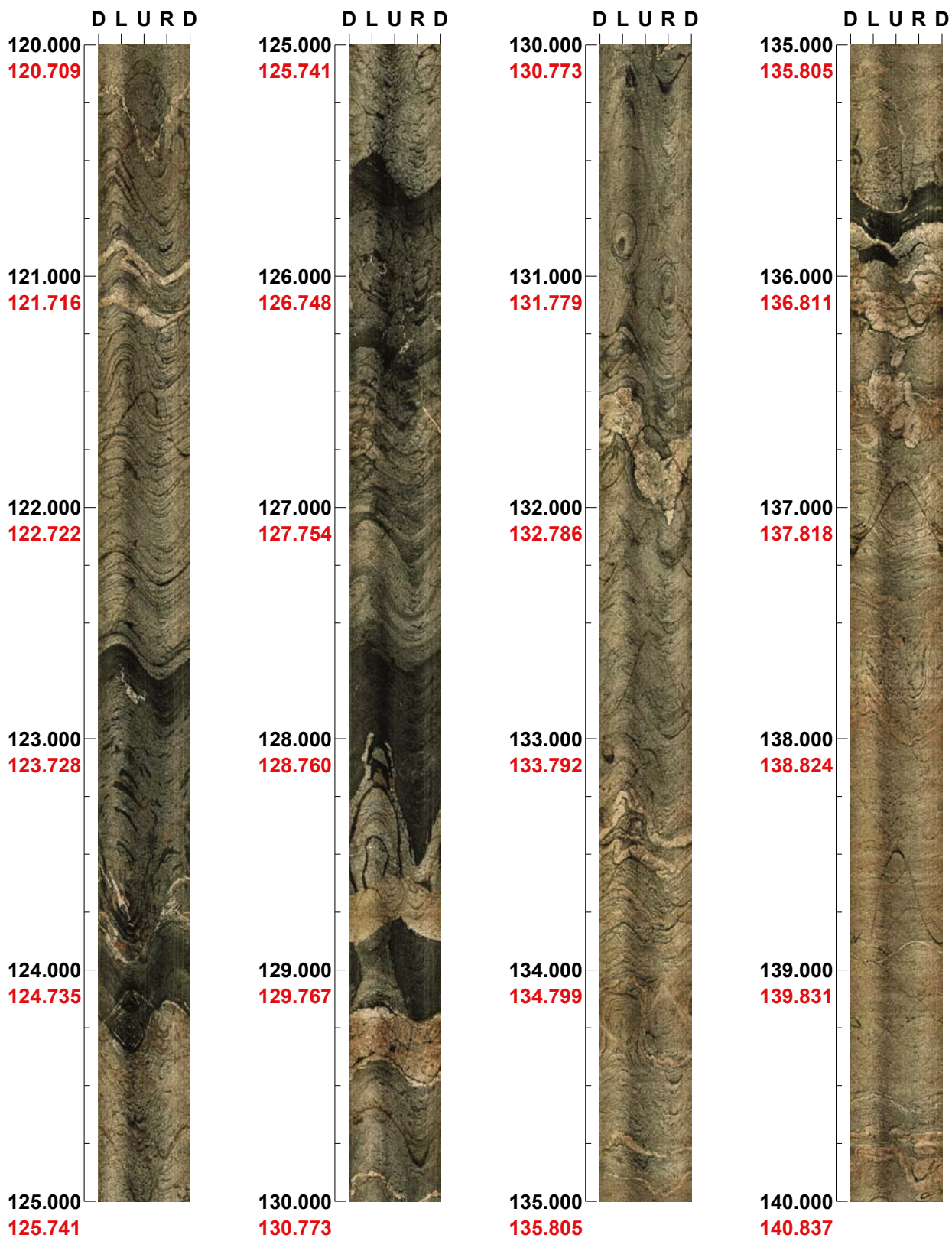

Project name: SFR
Bore hole No.: HFR106

Azimuth: 0

Inclination: -90

Depth range: 140.000 - 160.000 m

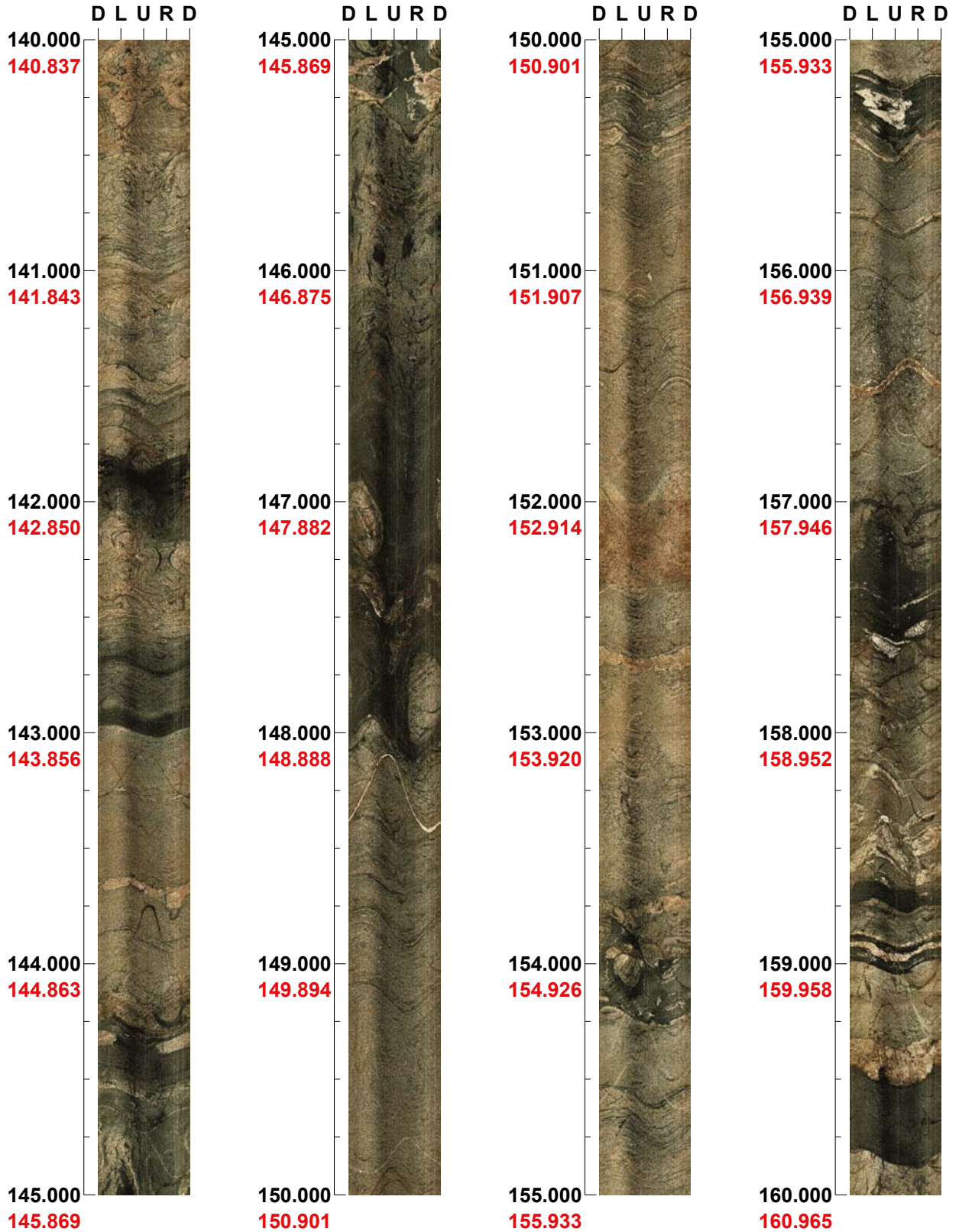

Project name: SFR
Bore hole No.: HFR106

Azimuth: 0

Inclination: -90

Depth range: 160.000 - 180.000 m

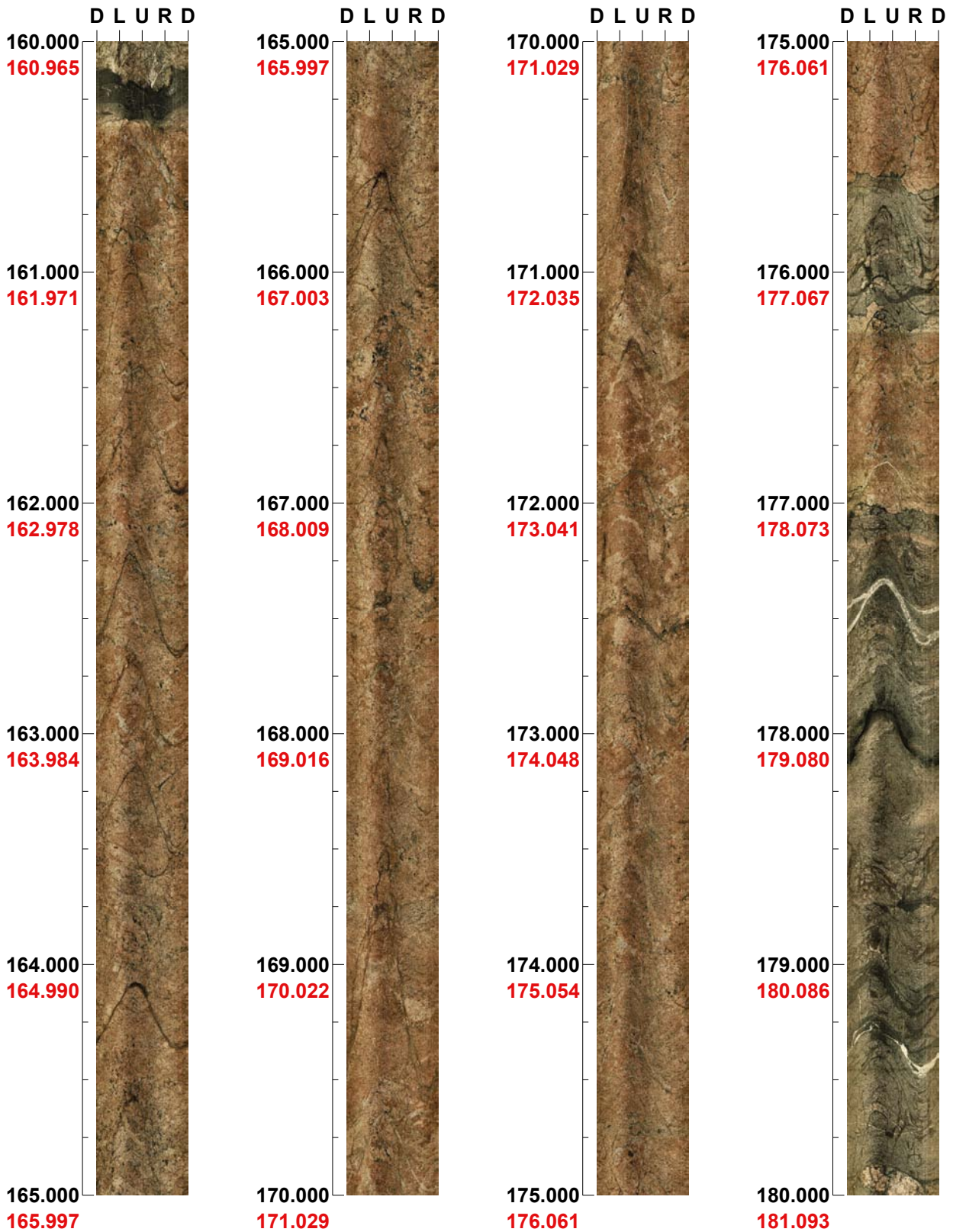

Project name: SFR
Bore hole No.: HFR106

Azimuth: 0

Inclination: -90

Depth range: 180.000 - 189.136 m

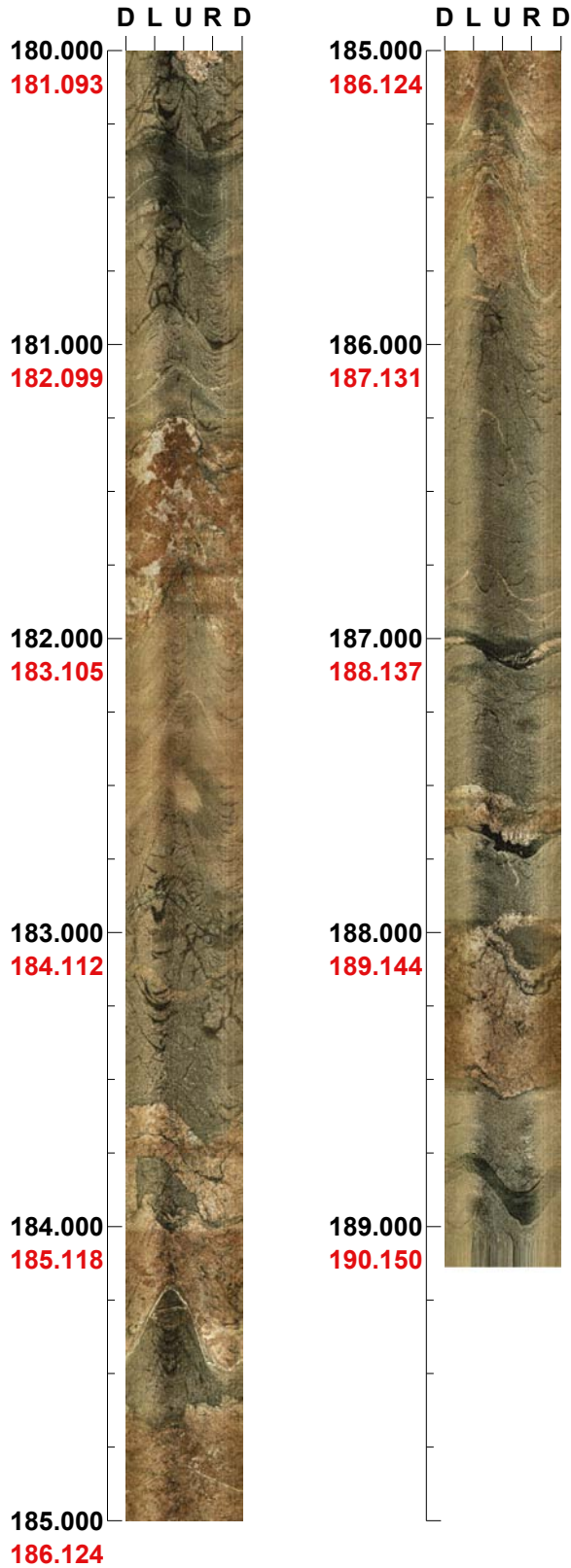

BIPS logging in HFR106, repeat section. 9 to 20 m.

Project name: SFR

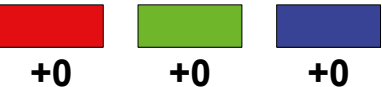
Image file : d:\work\r58xxs~1\bips\hfr106~1.bip
BDT file :
Locality : SFR
Bore hole number : HFR106
Date : 09/09/23
Time : 14:47:00
Depth range : 9.000 - 20.001 m
Azimuth : 0
Inclination : -90
Diameter : 138.0 mm
Magnetic declination : 0.0
Span : 4
Scan interval : 0.25
Scan direction : To bottom
Scale : 1/25
Aspect ratio : 90 %
Pages : 2
Color : 

Project name: SFR
Bore hole No.: HFR106

Azimuth: 0

Inclination: -90

Depth range: 0.000 - 20.000 m

