

**International  
Progress Report**

**IPR-02-07**

## **Äspö Hard Rock Laboratory**

**Äspö Task Force on modelling of  
grounwater flow and transport  
of solutes**

**Proceedings from the 15<sup>th</sup> Task Force  
meeting at Goslar, Germany,  
September 11-13, 2001**

Mansueto Morosini (ed.)

Svensk Kärnbränslehantering AB

January 2002

**Svensk Kärnbränslehantering AB**

Swedish Nuclear Fuel  
and Waste Management Co  
Box 5864  
SE-102 40 Stockholm Sweden  
Tel +46 8 459 84 00  
Fax +46 8 661 57 19



**Äspö Hard Rock  
Laboratory**



Report no.  
IPR-02-07

Author  
Morosini

Checked by

Approved  
Christer Svemar

No.  
F65K  
Date  
02-01-01

Date

Date  
02-06-05

# Äspö Hard Rock Laboratory

## Äspö Task Force on modelling of grounwater flow and transport of solutes

### Proceedings from the 15<sup>th</sup> Task Force meeting at Goslar, Germany, September 11-13, 2001

Mansueto Morosini (ed.)

Svensk Kärnbränslehantering AB

January 2002

*Keywords:* Groundwater flow, solute transport, tracer test, fractured rock, underground laboratory, radionuclide, stochastic modelling, deterministic modelling



# Abstract

This report compiles the presentations of the modelling work done by different modelling groups in the Task Force since the previous meeting as presented at the 15<sup>th</sup> Task Force meeting held 11-13 September, 2001 at Goslar, Germany. The report also constitutes a status report of the Task Force work. The subject of this report is the work performed in the different modelling tasks. Task 4 is dealing with solute transport in one structural feature at a 5m scale. Task 5 is a hydrological-hydrochemical model assessment exercise that specifically studies the impact of the tunnel construction on the groundwater system at Äspö. Task 6 is addressing the issue of performing performance assessment modelling with site characterisation data.



# Sammanfattning

Föreliggande rapport är en sammanställning av det modelleringsarbete som presenterades under det 15:e Internationella Task Force mötet av de deltagande organisationernas modelleringsgrupper. Mötet hölls i Goslar, Tyskland 11-13 September 2001.

Denna rapport utgör även statusrapport för arbetet inom Äspö Task Force. Arbeta pågår inom tre modelleringsövningar Task 4,5 och 6. Inom Task 4 modelleras transport av lösta ämnen i en singel strukturgeologisk enhet i 5m skala. Task 5 är ett försök att värdera modellering där man utnyttjar både hydrologisk och hydrokemisk information vid modelleringen. Frågeställningen är tunneldrivningens påverkan på grundvattensystemet på Äspö. Inom Task 6 studeras olika frågeställningar vid säkerhetsanalysmodellering med platsundersökningsdata.





# Contents

<b>1</b>	<b>Introduction</b>	<b>7</b>
<b>2</b>	<b>Scope</b>	<b>9</b>
<b>3</b>	<b>Task 4 – Tracer retention and understanding experiments, 1<sup>st</sup> stage</b>	<b>11</b>
3.1	Background	11
3.2	Overview of TRUE-1 tracer test experiments	11
3.3	Results Task 4	13
<b>4</b>	<b>Task 5 – Integration of hydrochemistry and hydrogeology</b>	<b>15</b>
4.1	Background	15
4.2	Work performed	15
<b>5</b>	<b>Task 6 – Performance Assessment Modelling Using Site Characterisation Data (PASC)</b>	<b>17</b>
5.1	Background	17
5.2	Modelling tasks	17
5.3	Work performed	18
<b>6</b>	<b>References</b>	<b>21</b>
	<b>Appendices</b>	

## List of Figures

Figure 3-1. Borehole intersections with Feature A shown in the plane of the feature.  
Distances are given in metres.

## List of Tables

Table 5-1. List of presentations at the TF#15 meeting

# 1 Introduction

The Äspö Task Force on Modelling of Groundwater Flow and Transport of Solutes is a forum for the organisations supporting the Äspö HRL Project to interact in the area of conceptual and numerical modelling of groundwater flow and solute transport in fractured rock. In particular, the Task Force proposes, reviews, evaluates and contributes to such work in the Project.

The work within the Äspö Task Force constitutes an important part of the international co-operation within the Äspö Hard Rock Laboratory. The group was initiated by SKB in 1992 and is a forum for the organisations to interact in the area of conceptual and numerical modelling of groundwater flow and transport. The work within the Task Force is being performed on well-defined and focused Modelling Tasks and the following have been defined so far:

- **Task No 1:** The LPT-2 pumping and tracer experiments. Site scale.
- **Task No 2:** Scoping calculations for a number of planned experiments at the Äspö site. Detailed scale.
- **Task No 3:** The hydraulic impact of the Äspö tunnel excavation. Site scale.
- **Task No 4:** TRUE - The Tracer Retention and Understanding Experiment, 1<sup>st</sup> stage. Non-reactive and reactive tracer tests. Detailed scale.
- **Task No 5:** Impact of the tunnel construction on the groundwater system at Äspö, a hydrological-hydrochemical model assessment exercise.
- **Task No 6:** Performance Assessment modelling using Site Characterisation data (PASC).

Eight organisations in addition to SKB are participating in the Äspö HRL. Together these organisations involve twelve modelling groups.

The participating organisations are: Japan Nuclear Cycle Corporation (JNC), Japan; Central Research Institute of Electric Power Industry (CRIEPI), Japan; Agence National Pour la Gestion des Déchets Radioactifs (ANDRA), France; Posiva Oy, Finland; Nationale Genossenschaft für die Lagerung von radioaktiver Abfälle (NAGRA), Switzerland; Bundesministerium für Bildung, Wissenschaft, Forschung und Technologie (BMWi), Germany, Empresa Nacional de Residuos Radiactivos (ENRESA), Spain and US DOE/Sandia National Laboratories, USA.



## 2 Scope

This report is a compilation of the presentations given at the meeting that addressed the status of the experimental work at Äspö and the work performed by the modelling teams since the previous meeting.

Chapters 3-5 give an overview and background of the experiment which form the basis for the modelling in Task 4, 5 and 6. The content of each presentation is given in the appendix.

This proceeding also constitutes a status report of the Task Force work. Tasks 1-3 have been completed and the subject of this report is the work performed in Task 4, 5 and 6.



### **3 Task 4 –**

## **Tracer retention and understanding experiments, 1<sup>st</sup> stage**

### **3.1 Background**

Within the Äspö HRL project, a programme called Tracer Retention Understanding Experiments (TRUE) has been defined for tracer tests at different experimental scales. The overall objective of the TRUE experiments is to increase the understanding of the processes which govern retention of radionuclides transported in crystalline rock, and to increase the credibility in computer models for radionuclide transport which will be used in the licensing of a repository.

The first tracer test cycle (TRUE-1) constitutes a training and testing exercise for tracer test technology on a detailed scale using non-reactive and reactive tracers in a simple test geometry. In addition, supporting technology development is performed in order to understand tracer transport through detailed aperture distributions obtained from resin injection. The TRUE-1 test cycle is expected to contribute data and experience that will constitute the necessary platform for subsequent, more elaborate experiments within TRUE.

### **3.2 Overview of TRUE-1 tracer test experiments**

The Modelling Task 4 consist of several modelling exercises in support of the TRUE-1 tracer tests including predictive modelling where the experimental results are not available beforehand. Previous modelling task, that are now completed are:

- Task 4A consisted of modelling in support of the development of the descriptive structural model of the test site.
- Task 4B whose scope of was to perform modelling in support of the experimental design.
- Tasks 4C and 4D were defined to perform predictive modelling of non-sorbing tracer tests at the TRUE-1 site, including a comparison of model outputs with experimental results.

All these tasks were to a great extent preparatory steps for Tasks 4E and 4F that comprise predictive modelling of tracer tests performed with collection of sorbing, slightly sorbing and non-sorbing tracers. These tests were performed between packed off boreholes penetrating a water-conducting geological feature with a “simple” structure, Feature A. The tracer tests were preceded by a characterisation of the site and a preliminary tracer experiment.

### *Task 4E and 4F*

Task 4E and 4F are based on data from sorbing tracer tests. The objectives of the sorbing tracer test part of TRUE-1 /Andersson et al, 1997B/ are:

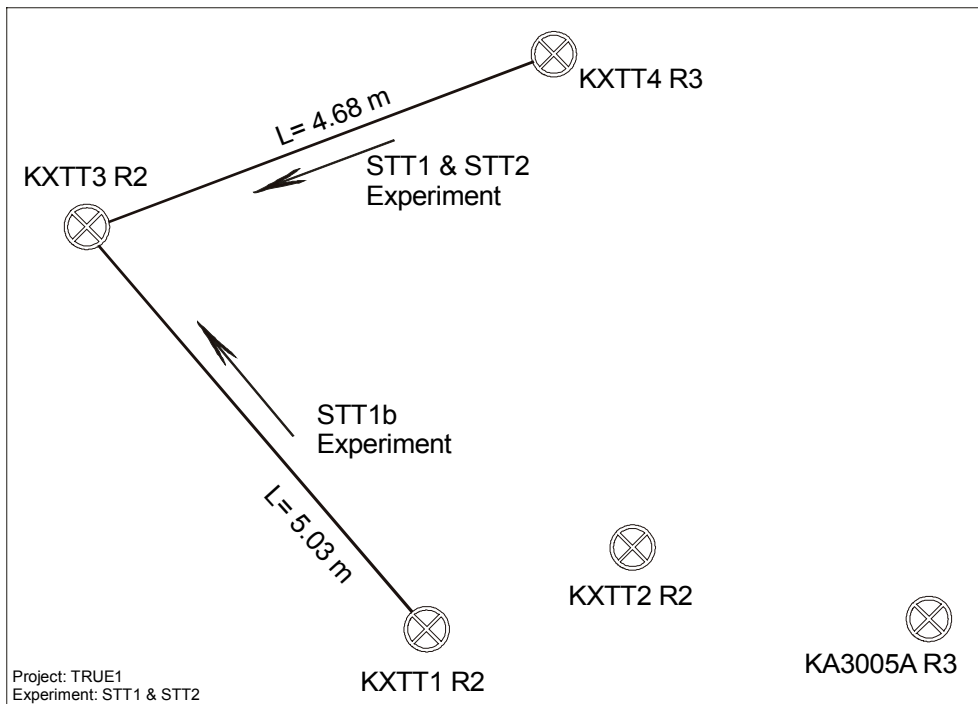
- Test equipment and methodology for performing tracer tests with weakly sorbing radioactive tracers
- Increase understanding of transport of tracers subject to sorption in the studied feature
- Obtain parameters which describe retention of tracer transport
- Test different weakly and moderately sorbing radioactive tracers

The overall experimental scope includes:

- Two main geometrical configurations KXTT4:R3->KXTT3:R2 and KXTT1:R2->KXTT3:R2
- 2 pump rates
- Weakly (Na, Ca, Sr) and moderately (Rb, Cs, Ba) sorbing tracers as well as the two non-sorbing tracers tritiated water and uranine.
- STT-1 (q=400 ml/min): highest flow rate, diffusion into the matrix (dead end pores are minimised). Flowpath was KXTT4:R3 -> KXTT3:R2.
- STT-1b: A complementary injection of sorbing tracers in KXTT1:R2 (q=400 ml/min)
- STT-2 (q=200 ml/min): intermediate flow rate, surface sorption, however there are questions regarding the effect of diffusion into the rock matrix. Flowpath was KXTT4:R3 -> KXTT3:R2.

The TRUE-1 experiment which form the basis for this modelling task has been completed and is reported in Winberg et al (2000) and Cvetkovic et al (2000).





**Figure 3-1** Borehole intersections with Feature A shown in the plane of the feature. Distances are given in metres.

### 3.3 Results Task 4

All work by the modelling teams within this task has been completed. Additionally, evaluation of the modelling done in Task 4C / 4D (Elert, 1999) and 4E / 4F (Elert & Svensson, 2001) have been undertaken. A round up of the latter work was done at the meeting (Appendix B). Results from experiment and its related modelling raised the issue of discrimination between heterogeneity and source function. This warranted two modelling exercises for Task 4E (Elert & Svensson, 1999) and 4F (Elert & Svensson, 2000) respectively where deconvolution of breakthrough curves was applied. Work within the TRUE-1 site will continue under the framework of a new project called TRUE Continuation that also includes components from the TRUE Block Scale site (Appendix C).

Still on going is the overall evaluation for Task 4 with the purpose of to address understanding, methodologies and motivation/expectations from the viewpoint of the participating organisations. Status of this work is presented in Appendix D.



## 4 Task 5 –

# Integration of hydrochemistry and hydrogeology

### 4.1 Background

The chemical composition of the groundwater is a result of the interaction with the rock minerals and the groundwater. The degree of interaction is a function of groundwater transport and residence time. It is therefore of interest to study the combined hydrodynamic and hydrochemical evolution of a groundwater system. However, major difficulties are recognised because the present day (and past) hydrodynamic conditions have resulted in groundwater mixing to varying degree.

The fifth modelling task of the Äspö Task Force, Task No 5, is a hydrological-hydrochemical model assessment exercise that specifically studies the impact of the tunnel construction on the groundwater system at Äspö. The task definition has been successively refined resulting in the following major objectives:

- Assess the consistency of groundwater flow models and hydrochemical mixing-reaction models through integration and comparison of hydraulic and chemical data obtained before and during tunnel construction.
- Develop a procedure for integrating hydrological and hydrochemical information that could be used in the assessment of potential disposal sites.

Organisations participating in this modelling task are SKB, ANDRA, POSIVA, BMWi, JNC, CRIEPI and ENRESA.

The modelling is performed with the objective to replicate observed groundwater compositions and flow into the tunnel and at a few control points away from the tunnel.

### 4.2 Work performed

The modelling exercises by the different modelling groups have all been completed and the reports are ready for printing. Work is underway to compile results and summarise approach, execution and conclusions of Task 5 into one summary report. Prior to the meeting an incomplete draft summary report was distributed. Its content and results were presented at the meeting, Appendix E and F.

Work is also on going with the external reviewers' report. Prior to the meeting an incomplete draft report was distributed to all modellers and Delegates, the results of which was presented in the meeting (Appendix G)



## 5 Task 6 –

# Performance Assessment Modelling Using Site Characterisation Data (PASC)

### 5.1 Background

Task 6 is developed in the context of arguments concerning the usefulness of *in situ* tracer experiments for PA requiring an understanding of slower processes which are sometimes difficult to observe during short duration tracer experiments; *in situ* tracer experiments are dominated by rather faster processes.

Task 6 tries to bridge the gap between Performance Assessment (PA) and Site Characterisation (SC) models by applying both approaches for the same tracer experiment, and also for PA boundary conditions. It is hoped this will help to identify the relevant conceptualisations (in processes/structures) for longer-term PA predictions and identify site characterisation data requirements to support PA calculations. The objectives with this task are to:

1. Assess simplifications used in PA models.
2. Assess the constraining power of tracer (and flow) experiments for PA models.
3. Provide input for site characterisation programs from a PA perspective (i.e., provide support for site characterisation program design and execution aimed at delivering needed data for PA).
4. Understand the site-specific flow and transport behaviour at different scales using SC models.

### 5.2 Modelling tasks

The following specific modelling tasks have been defined<sup>1</sup>:

**Task 6A.** Model and reproduce selected TRUE-1 tests with a PA model and/or a SC model to provide a common reference.

**Task 6B.** Model selected PA cases at the TRUE-1 site with new PA relevant (long term/base case) boundary conditions and temporal scales to understand the differences between the use of SC-type and PA-type models, and the influence of various assumptions made for PA calculations for extrapolation in time.

**Task 6C.** Develop a 50-100m block scale synthesised structural model using data from the Prototype Repository, TRUE Block Scale, TRUE-1 and FCC.

**Task 6D.** Task 6D is similar to Task 6A, using the synthetic structural model and a 50 to 100 m scale TRUE-Block Scale tracer experiment.

**Task 6E.** Task 6E extends the Task 6D transport calculations to a reference set of PA time scales and boundary conditions.

---

<sup>1</sup> These are short versions based on the task definition

### **5.3 Work performed**

Modelling for task 6A and 6B has been performed based on the first data delivery which comprised the modelling task specification for Task 6A and 6B, the tracer test data from STT1b including injection, breakthrough and groundwater head.

Prior to the meeting a one day workshop was held to discuss the approach of constructing a synthetic structural model. The basis for the discussion comprised a proposal that was distributed prior to the meeting (Appendix U) and some general reflections on experiences from the TRUE Block Scale project and ways of working (Appendix V).

Results of this modelling were presented and discussed during the meeting. Presentations are compiled in Appendix H-T.

**Table 5-1. List of presentation at the TF#15 meeting**

<b>Title</b>	<b>Author</b>	<b>Appendix #</b>
T6C Introduction.	J-O Selroos (SKB).	H
T6DE Issues.	J-O Selroos (SKB).	I
Models used for T6A&B in 2D and 3D	L. Moreno (CE-KTH/SKB)	J
Results of modelling T6A&B	J. Crawford (CE-KTH/SKB)	K
Pathway and microstructure channel network model for 5m scale radionuclide transport	W. Dershowits (Golder/JNC)	L
Demonstration simulations for T6B2 fracture network flow and transport	W. Dershowits (Golder/JNC)	M
Modeling of T6A&B	A. Poteri (VTT/POSIVA)	N
Modelling of STT1B for T6A&B	H. Cheng (WRE-KTH/SKB)	O
FRAME: A subgrid model based on FRactal scaling laws and multi rate equations	U. Svensson (CFE/SKB)	P
Simulation results for T6A&B	S. Follin (SF GeoLogic/SKB)	Q
Task 6A and 6B Modelling with 3FLO	D. Billaux (ITASCA/ANDRA)	R
Simulated Flow and Transport through Two-dimensional Stochastically Heterogeneous Feature A Fracture Plane using a Multi-rate Transport Model	T. Feeney (SANDIA/USDOE)	S
Task 6A and 6B Orientations and preliminary results	C. Grenier (CEA/ANDRA)	T
<b>Task 6C workshop</b>		
Proposal for Construction of a Semi-Synthetic conceptual hydrostructural model	A Winberg (Conterra)	U
Views on task 6	M. Mazurek (University of Bern)	V





## 6 References

**Cvetkovic, V., Cheng, H., Selroos, J-O. 2000.** First TRUE stage. Evaluation of tracer retention experiments (first stage) at Äspö. SKB International Cooperation Report ICR-00-01.

**Elert M, Svensson H, 2001.** Evaluation of modelling of the TRUE-1 radially converging tests with sorbing tracers. The Äspö Task Force on Modelling Groundwater Flow and Transport of Solutes. Tasks 4E and 4F. SKB Technical Report TR-01-12.

**Elert M, Svensson H, 1999.** Evaluation of modelling of the TRUE-1 radially converging tests and dipole tests with conservative tracers. The Äspö Task Force on Modelling Groundwater Flow and Transport of Solutes. Tasks 4C and 4D. SKB Technical Report TR-99-04.

**Elert M, Svensson H, 2000.** Äspö Hard Rock Laboratory. Deconvolution of breakthrough curves from TRUE-1 tracer tests (STT-2) with sorbing tracers. Äspö Task Force, Task 4F. SKB International Progress Report IPR-00-22.

**Elert M, Svensson H. 2000.** Äspö Hard Rock Laboratory. Deconvolution of breakthrough curves from TRUE-1 tracer tests (STT-1 and STT-1b) with sorbing tracers. Äspö Task Force, Task 4E. SKB International Progress Report IPR-99-35

**Morosini M, 2001.** Äspö Hard Rock Laboratory. Äspö Task Force on Modelling of Groundwater Flow and Transport of Solutes. Proceedings from the 14th Task Force meeting at Säröhus, Sweden, November 14-16, 2001. Part 1 of 2: Descriptions and Task 4 contributions and Part 2 of 2: Task 5 and Task 6 contributions. SKB International Progress Report IPR-01-30.

**Winberg, A., Andersson, P., Hermansson, J., Byegård, J., Cvetkovic, V., Birgersson, L. 2000.** Final report of the first stage of the tracer retention understanding experiments. Äspö Hard Rock Laboratory. SKB Technical Report TR-00-07.



# Appendices

## ÄSPÖ

A. Status of work at Äspö, P. Wikberg (SKB)

## TASK 4

B. Round up of Task 4EF Evaluation, M. Elert (Kemakta)

C. TRUE1 way forward, A. Winberg (Conterra)

D. Task 4 Overall Evaluation, P. Marshall (Nagra)

## TASK 5

E. Summary report (I. Rhén)

F. Summary report (J. Smellie)

G. Task 5 Reviewer report, A. Bath/P. Jackson (Intelligisci/Serco)

## TASK 6

H. T6C Introduction (J-O Selroos, SKB)

I. T6DE Issues (J-O Selross, SKB)

J. Models used for T6A&B in 2D and 3D, L. Moreno (CE-KTH/SKB)

K. Results of modelling T6A&B, J. Crawford (CE-KTH/SKB)

L. Pathway and microstructure channel network model for 5m scale radionuclide transport, W. Dershowitz (Golder/JNC)

M. Demonstration simulations for T6B2 fracture network flow and transport, W. Dershowitz (Golder/JNC)

N. Modeling of T6A&B, A. Poteri (VTT/POSIVA)

O. Modelling of STT1B for T6A&B, H. Cheng (WRE-KTH/SKB)

P. FRAME: A subgrid model based on FRactal scaling laws and multi rate equations.  
U. Svensson (CFE/SKB)

Q. Simulation results for T6A&B, S. Follin (SF GeoLogic/SKB)

R. Task 6A and 6B Modelling with 3FLO. Billaux (ITASCA/ANDRA)

- S. Simulated Flow and Transport through Two-dimensional Stochastically Heterogeneous Feature A Fracture Plane using a Multi-rate Transport Model" T. Feeney (SANDIA/USDOE)
- T. Task 6A and 6B Orientations and preliminary results. C. Grenier (CEA/ANDRA)

**TASK 6C WORKSHOP**

- U. Proposal for Construction of a Semi-Synthetic conceptual hydrostructural model, A Winberg (Conterra)
- V. Views on Task 6, M. Mazurek (University of Bern)

## Appendix A

Status of work at Äspö  
P. Wikberg (SKB)

# Information Activities

During the first quarter of 2001  
2331 persons visited Äspö HRL  
compared to 2061 persons during  
the same period last year.



# Facility Operation

- Extensiv rock support program has been completed
- An automatic visitor control system is in the pipe-line
- 99% availability of the hoisting system
- Temporary office facility arranged in a two-storey house in Äspö village

# Barrier function of the host rock

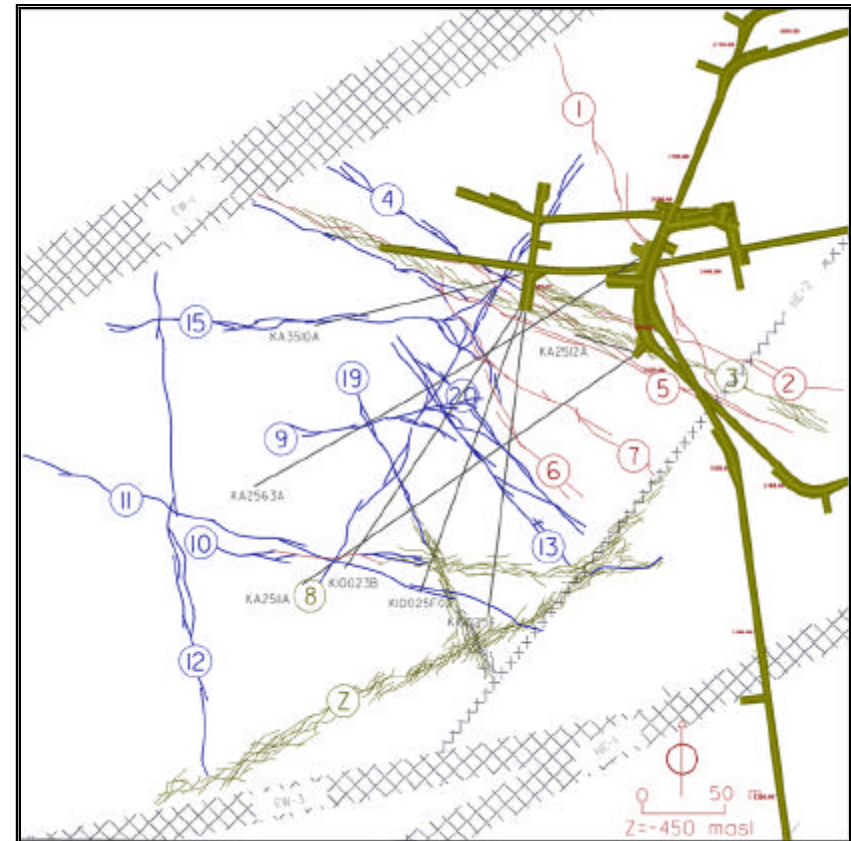
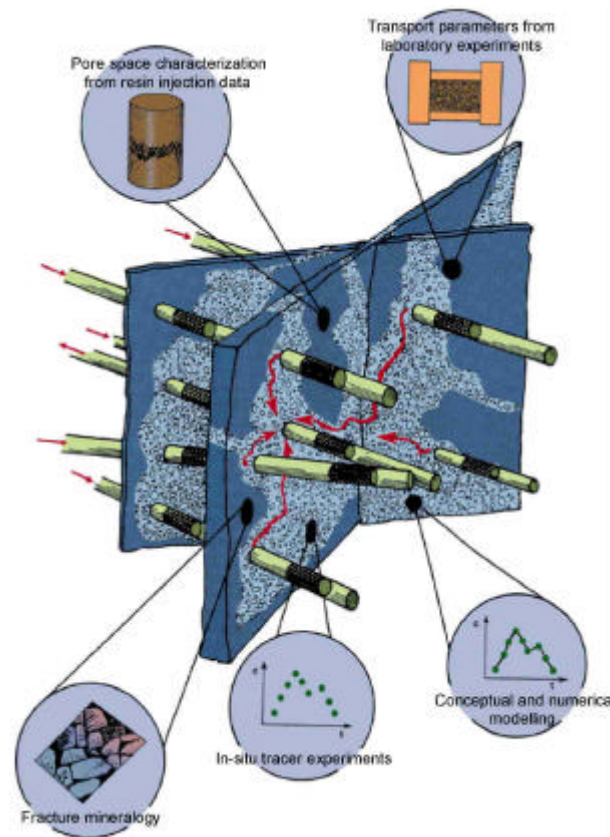
- TRUE 1 and TRUE Block Scale
- Long Term Diffusion Experiment - LTDE
- Chemlab 1 and Chemlab 2
- Two-phase Flow
- Matrix Fluid Chemistry
- Colloid
- MICROBE
- Task Force



# TRUE 1 and TRUE BS

New achievements since TEF 00:

- Final report of TRUE 1 published
- Experimental part of TRUE BS completed

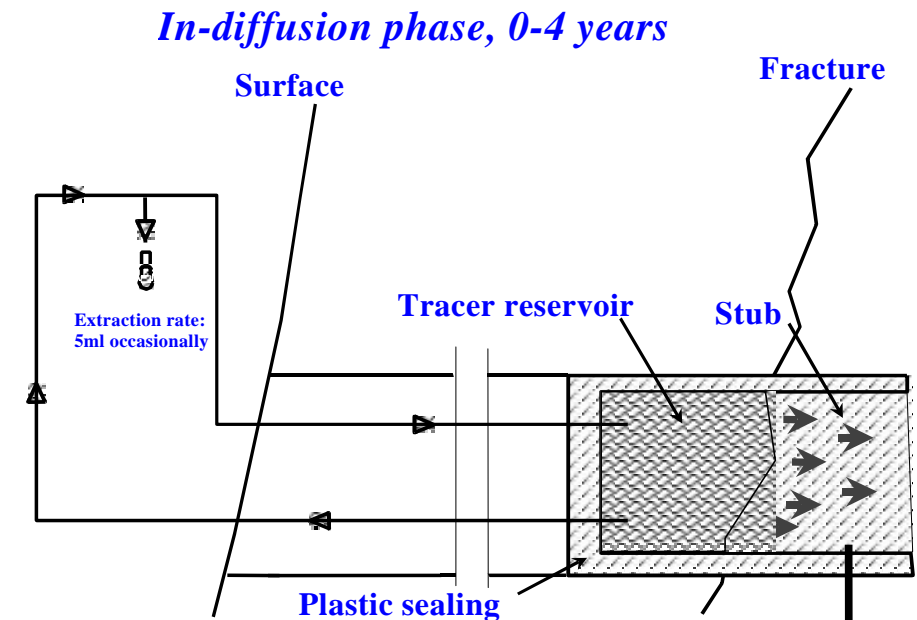


# LTDE

New achievements since TEF 00:

- Drilling and overcoring
- Geoscientific characterisation

## Experimental concept



*Extraction of the stub, after 4 years*

Sample drilling, slicing,  
grinding, leaching,  
dissolution (method  
depending on tracer)

Tracer concentration  
measurement (method  
depending on tracer)

# Radionuclide Retention and CHEMLAB 1 and 2

New achievements since

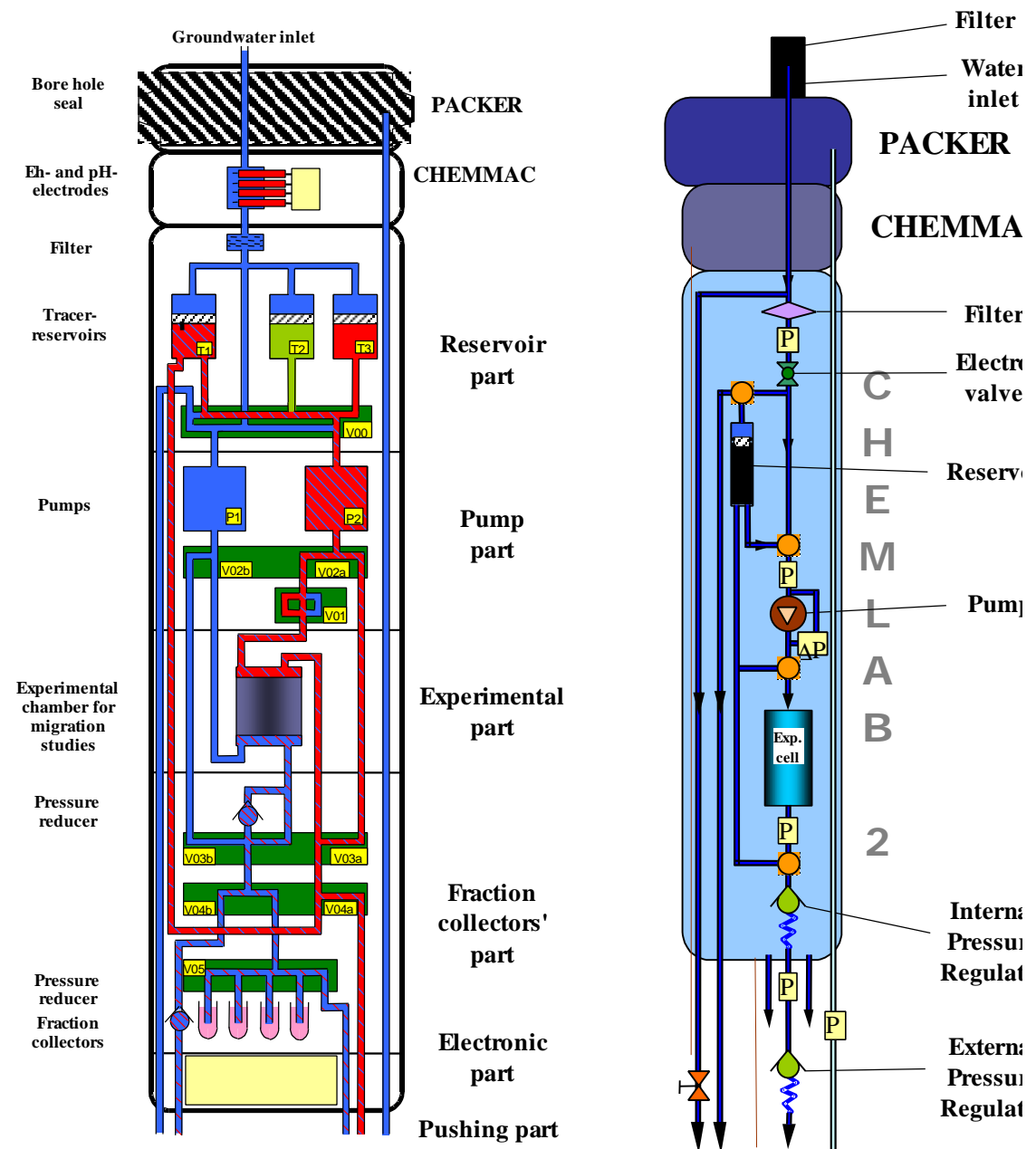
TEF 00:

Chemlab 1:

- Not in use

Chemlab 2:

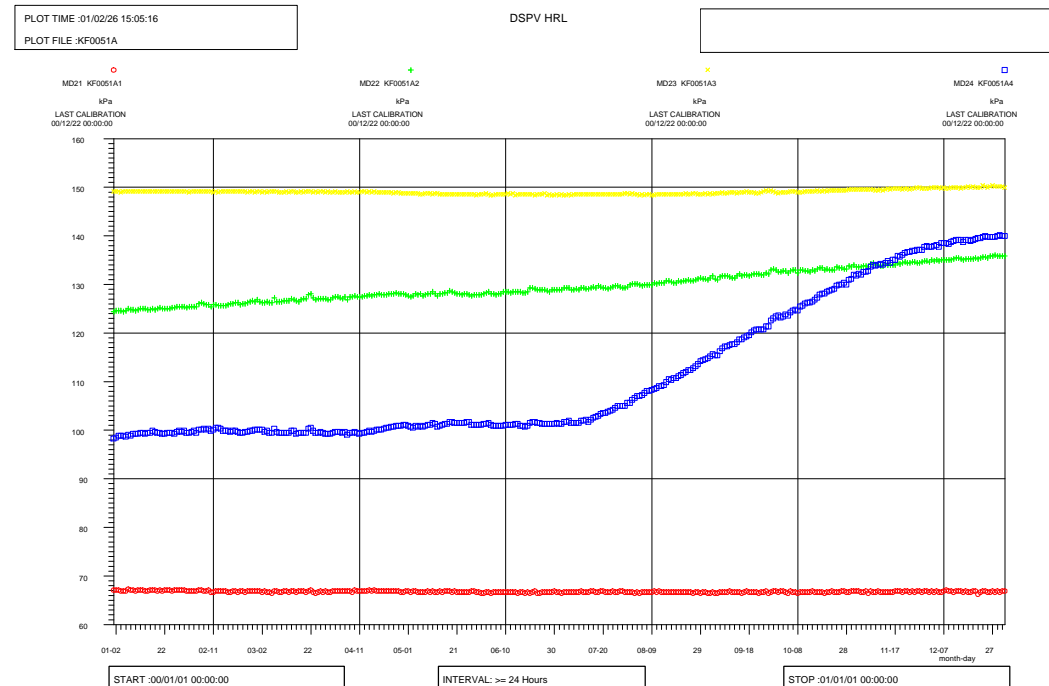
- Migration of actinides (Am, Np and Pu) in a rock fracture
- Analysis of rock sample



# Matrix Fluid Chemistry

## New achievement since TEF 00

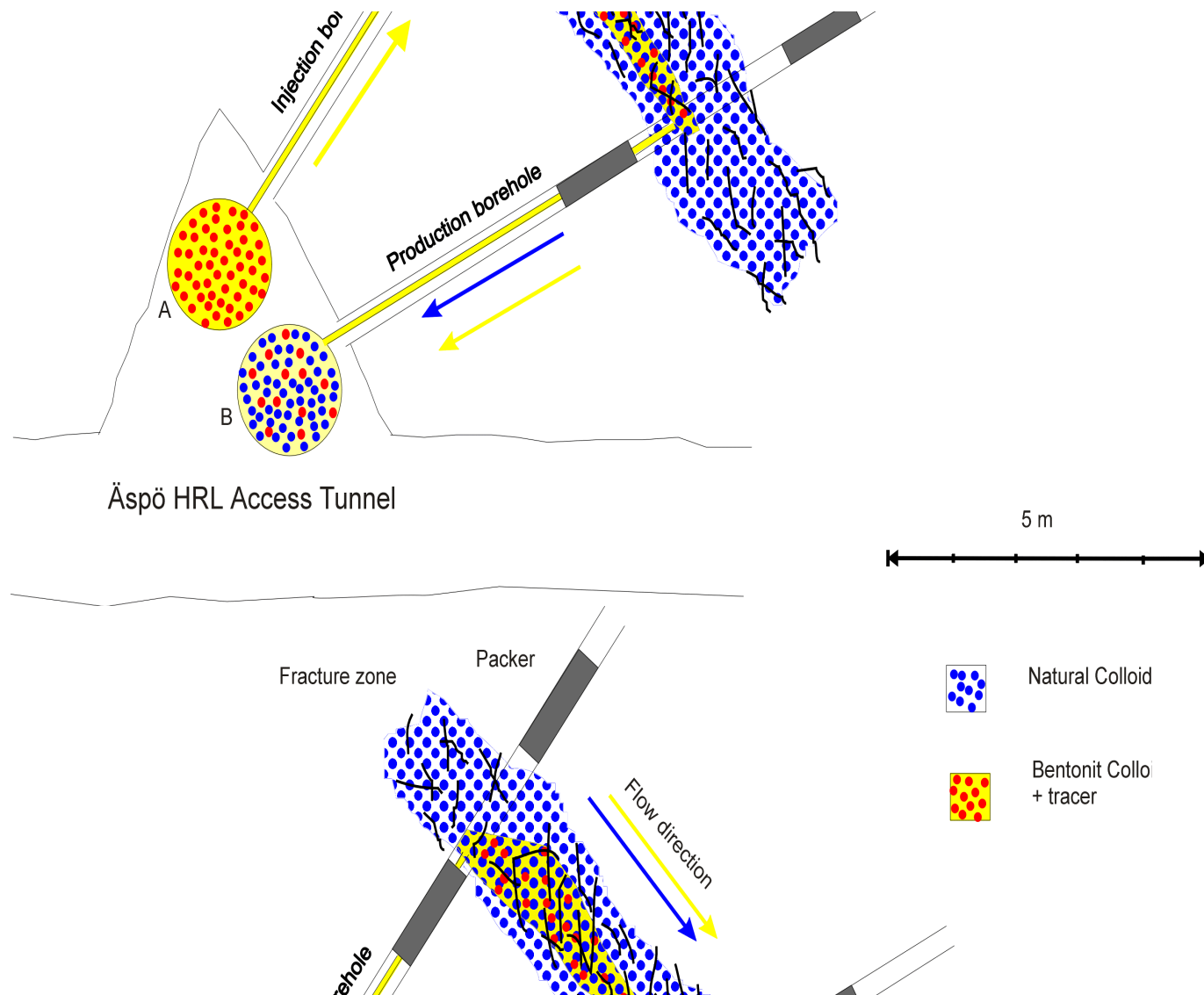
- Laboratory studies on mineralogy, porosity, permeability and leaching
- Steady pressure increase in Section 2 - the section in line for providing water samples



# Colloid

## New achievement since TEF 00

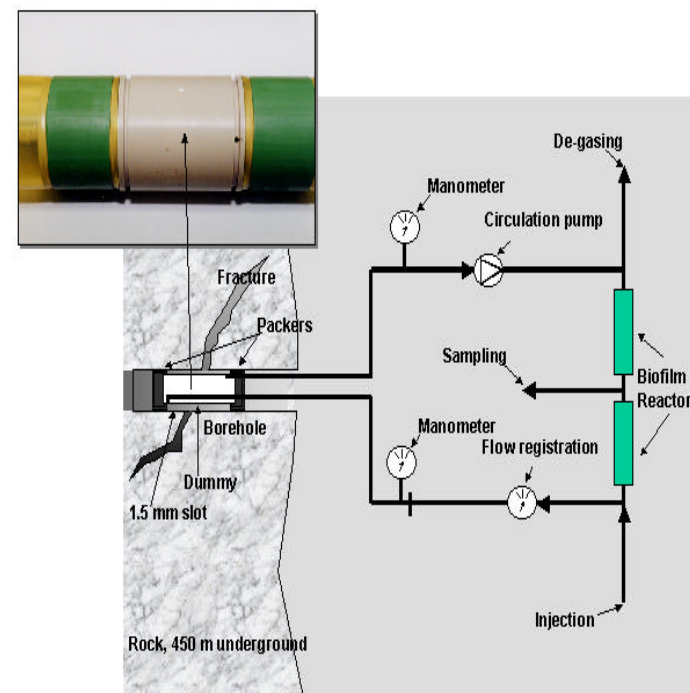
- Project decision  
obtained



# MICROBE

## New achievements since TEF 00

- Preparation of test site - boring of test hole
- Chemical and biological characterisation of bore hole



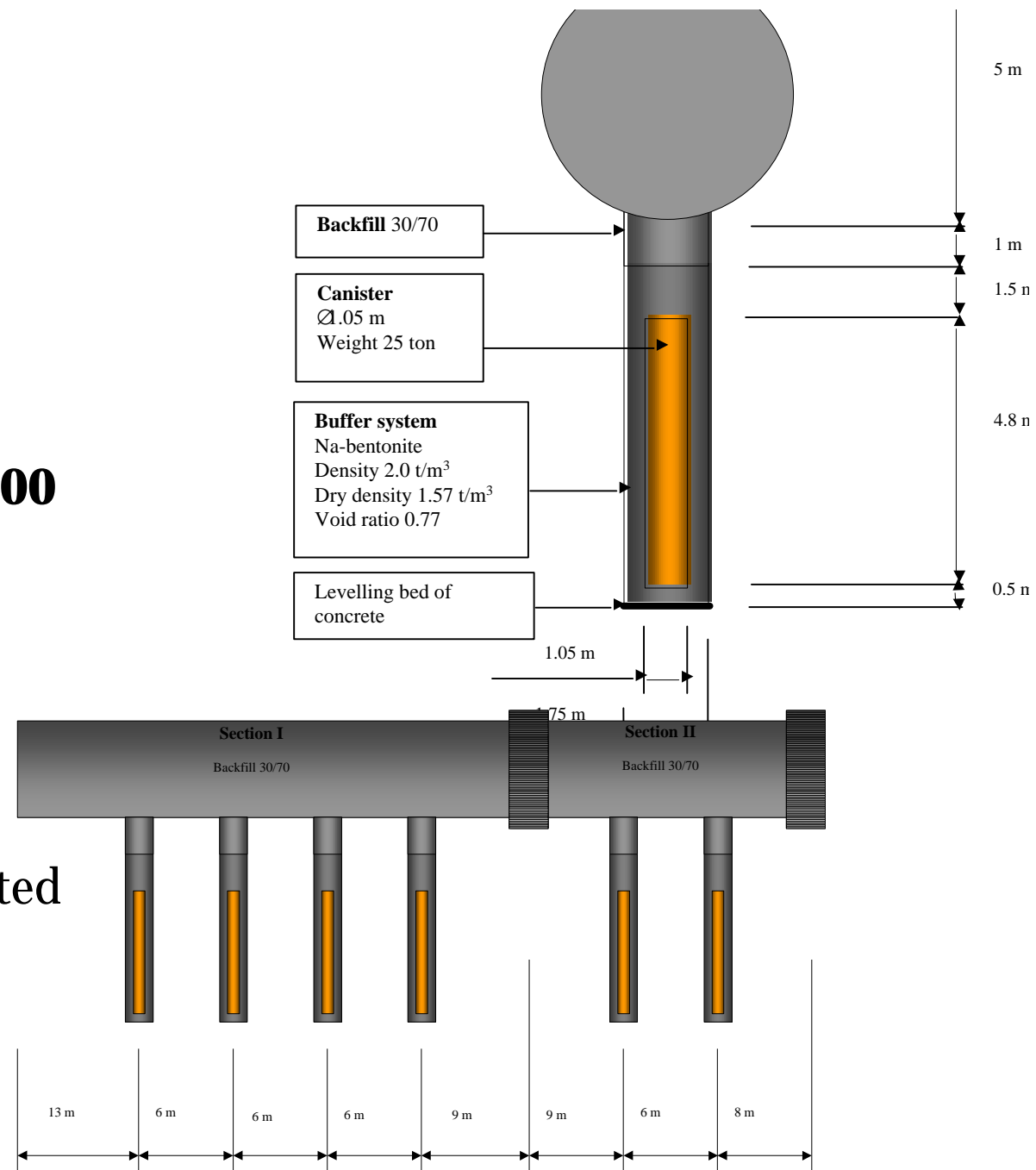
# Technology and important parts of the repository system

- Prototype Repository
- Backfill and Plug Test
- Canister Retrieval Test
- Long Term Test of Buffer Material - LOT
- DEMO of Disposal Technology

# Prototype Repository

## New achievement since TEF 00

- Hydrology characterisation completed
- Section I design completed
- Section I preparation completed
- Lead-throughs completed

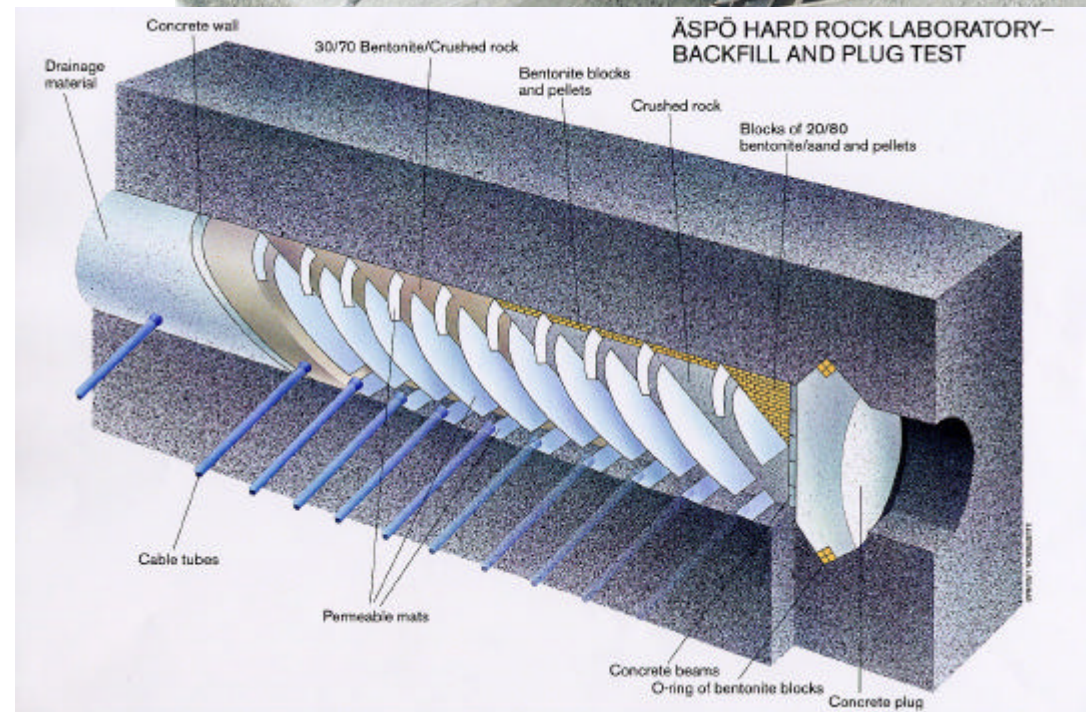




# Backfill and Plug Test

## New achievement since TEF 00

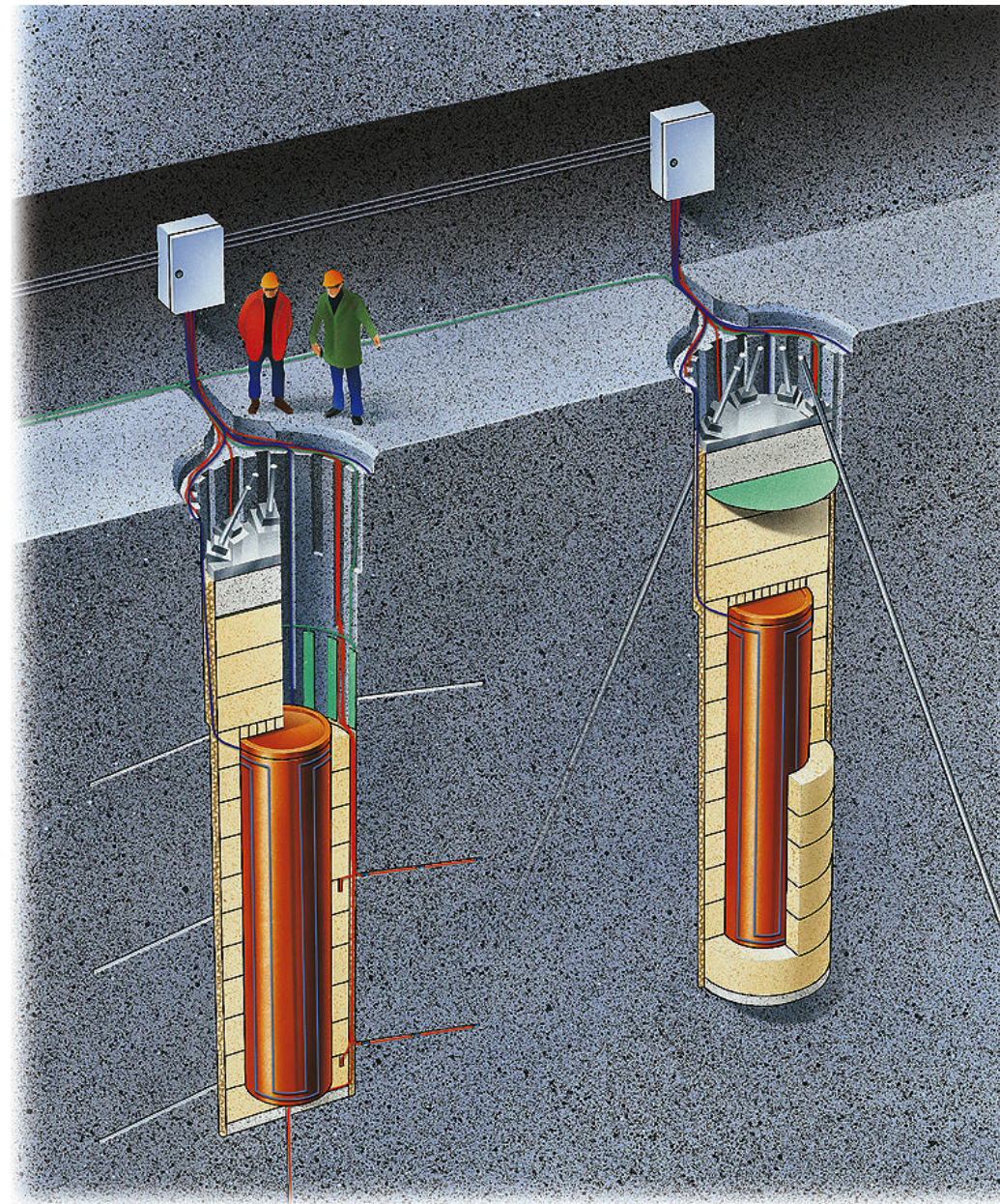
- Artificial saturation is slowly increasing the degree of saturation



# Canister Retrieval Test

## New achievements since TEF 00

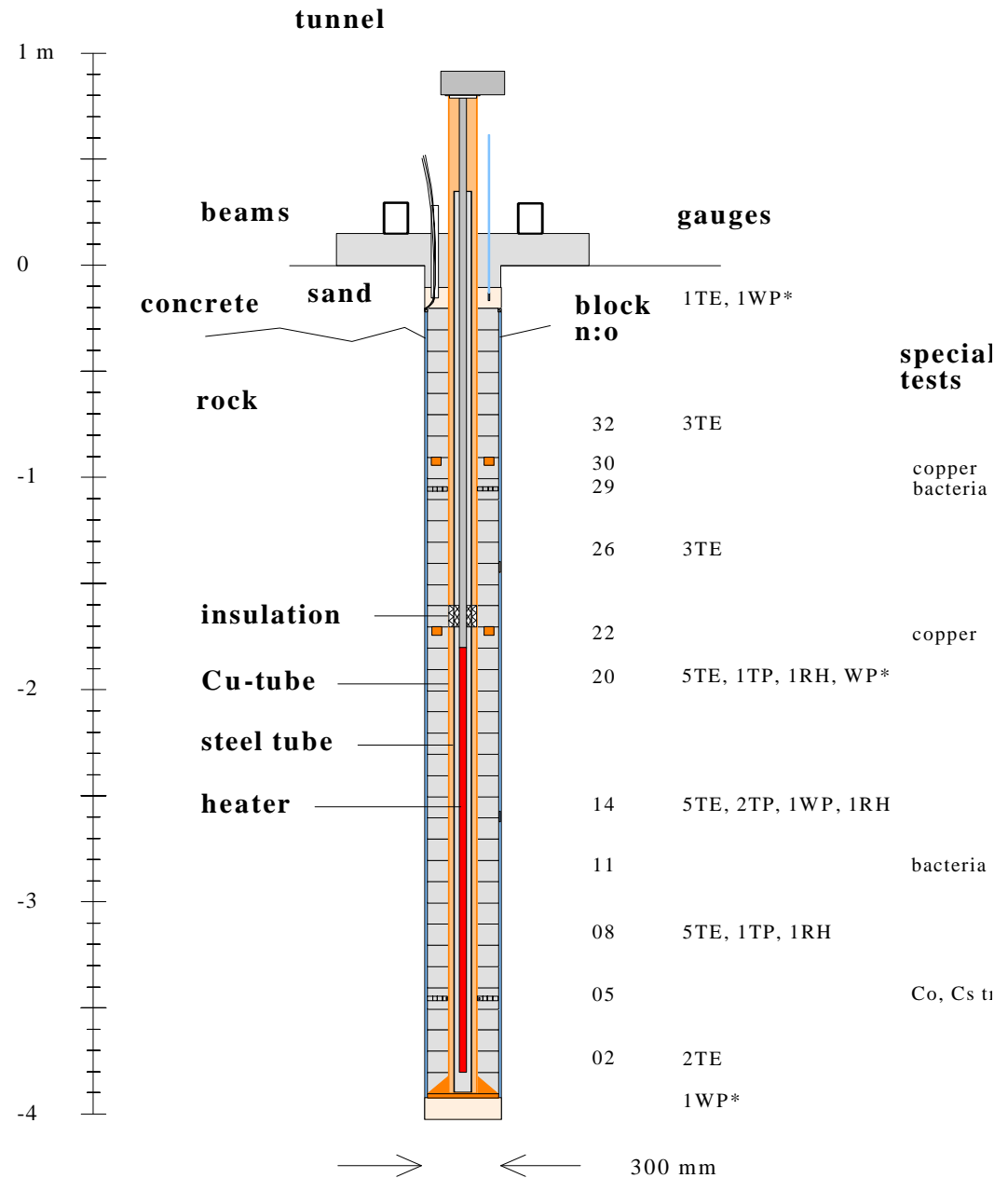
- Installation of one hole completed (second hole on stand-by)
- Heaters turned on with the aim to reach 90°C on canister's surface



# Long Term Test of Buffer Material - LOT

## New achievement since TEF 00

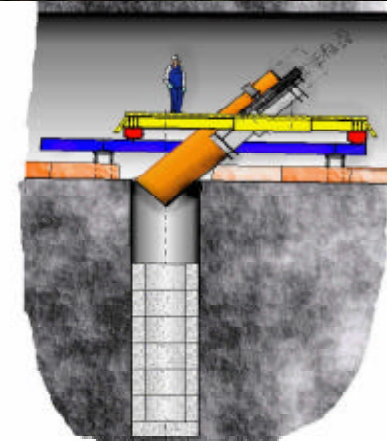
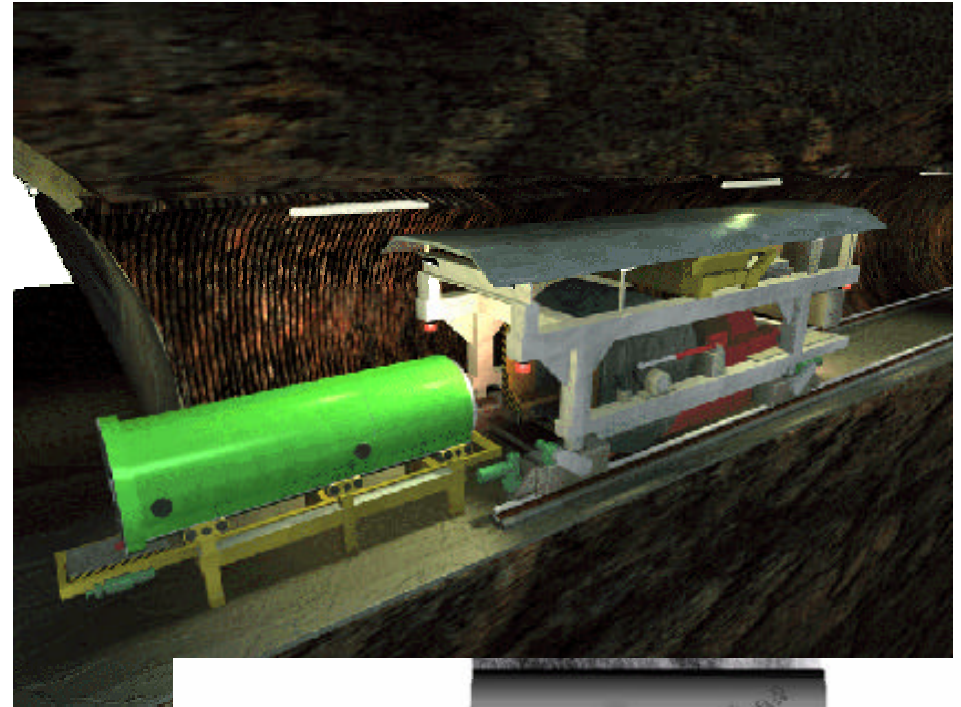
- Intended test temperatures of 90°C and 130°C respectively have been reached.



# DEMO of Disposal Technology

## New achievement since TEF 00

- Adjustment of machine function
- Testing of deposition sequences
- Construction, testing and operation of gantry crane and “small” deposition machine for installation of experiments
- New trailer as carrier for the “small” deposition machine to the Prototype Repository



End



## **Appendix B**

### **Round up of Task 4EF Evaluation** **M. Elert (Kemakta)**

---

# Evaluation of modelling of TRUE-1 radially converging tests with sorbing tracers

STT-1, STT-1b & STT-2  
Tasks 4E and 4F

---

Äspö Task Force meeting  
10-13 September 2001

Mark Elert

*Kemakta Konsult*

# Introduction

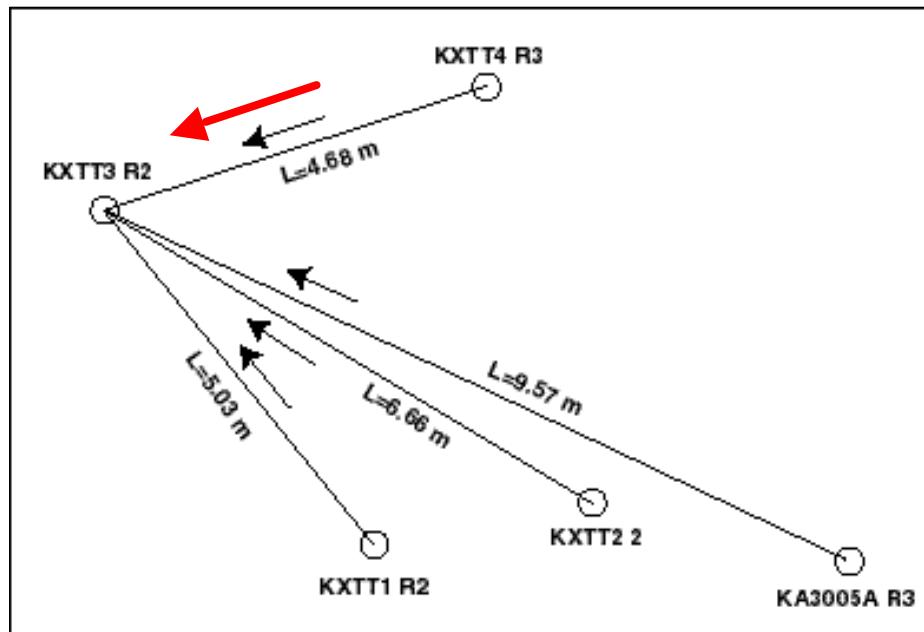
---

- Experiment
- Modelling approaches
- Processes and data
- Calibration and development
- Lessons learned and conclusions

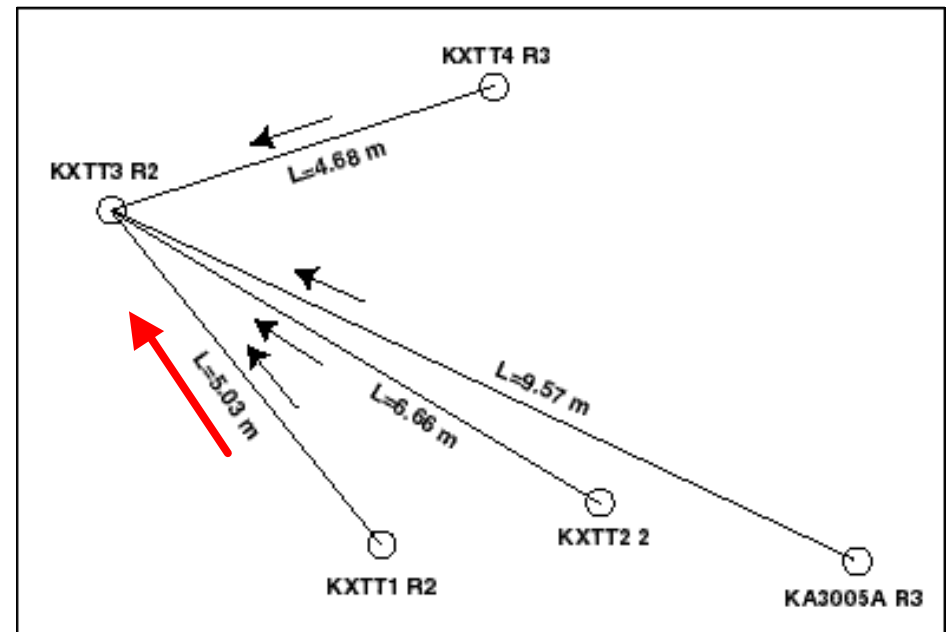


# Experiments

**STT-1** ( $Q=0.4$  l/min) & **STT-2** ( $Q=0.2$  l/min)

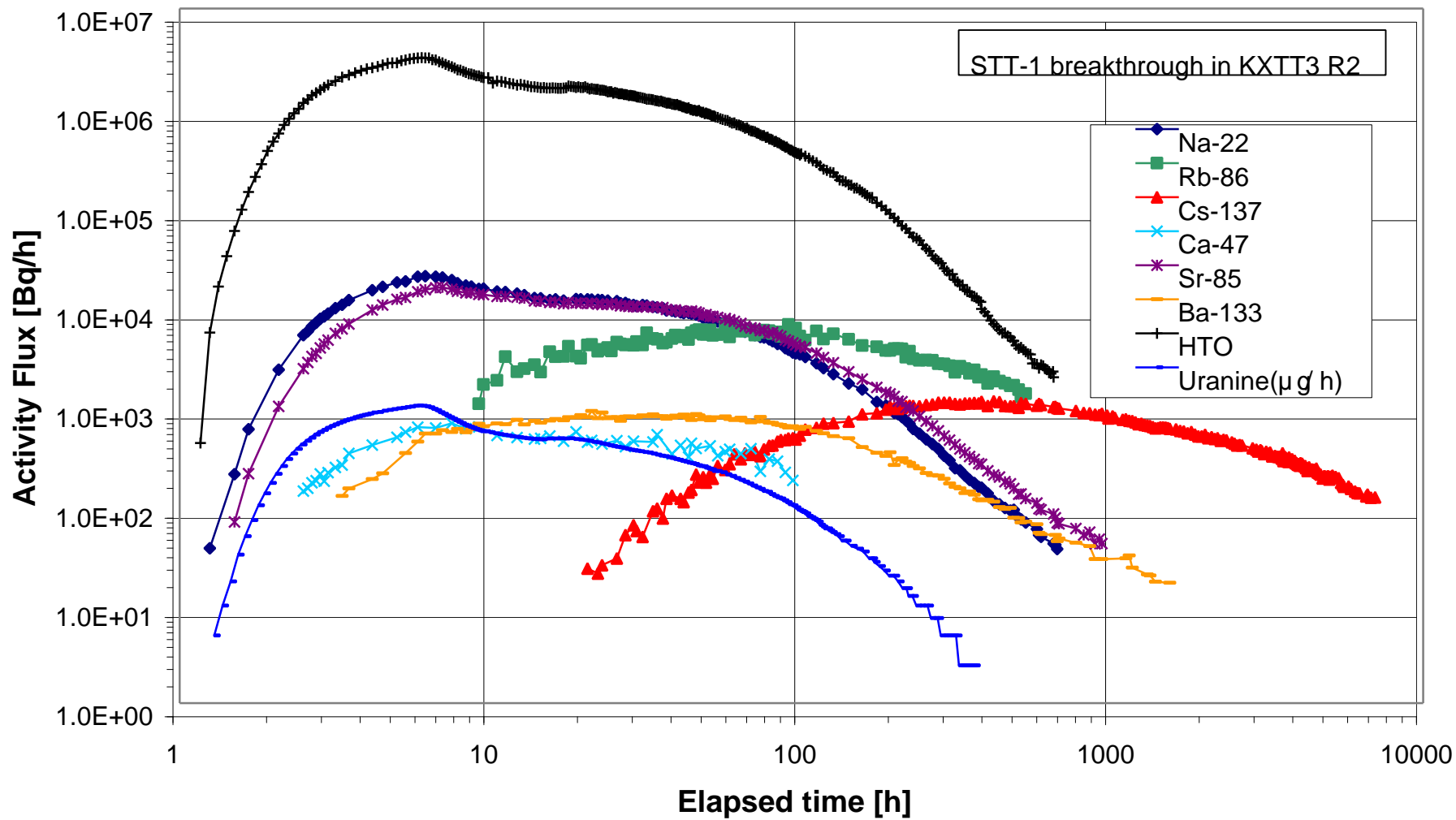


**STT-1b** ( $Q=0.4$  l/min)



Non-sorbing, weakly sorbing and moderately sorbing tracers

# Breakthrough curves from STT-1



# Participating organisations

---

Organisation	Modelling team	Representative	Task 4E	Task 4F
ANDRA	CEA-DMT	E Mouche	X	X
BMWi	BGR	L Liedtke	X	X
CRIEPI	CRIEPI	Y Tanaka	X	X
DOE	SANDIA	S McKenna		X
JNC	Golder Associates	W Dershowitz	X	X
NAGRA	PSI	A Jakob	X	X
POSIVA	VTT Energy	A Poteri	X	X
SKB	KTH-ChE	L Moreno	X	X
SKB	KTH-TRUE	J-O Selroos	X	X

# Modelling approaches - Types of models

---

- Modelling of flow
  - Deterministic continuum model (homogeneous/ heterogeneous)
  - Stochastic continuum
  - Discrete Fracture Network
  - Channel Network
- Modelling of transport
  - Advection-dispersion models
  - Lagrangian stochastic advection reaction model
  - Channel / Channel Network models
  - Multirate mass transfer model

# Model geometry and structural model

---

- Models from Task 4C & 4D generally retained
  - Majority treated Feature A as an isolated single feature
  - JNC/Golder DFN with three deterministic features and stochastic background fractures
  - SKB/KTH-ChE Channel network - Feature B and tunnel
  - BMWi/BGR Feature A and Feature B
- Revised structural model included to some extent
  - different types of geological materials (altered rock, cataclasite, gouge material)

# Modelling of processes

---

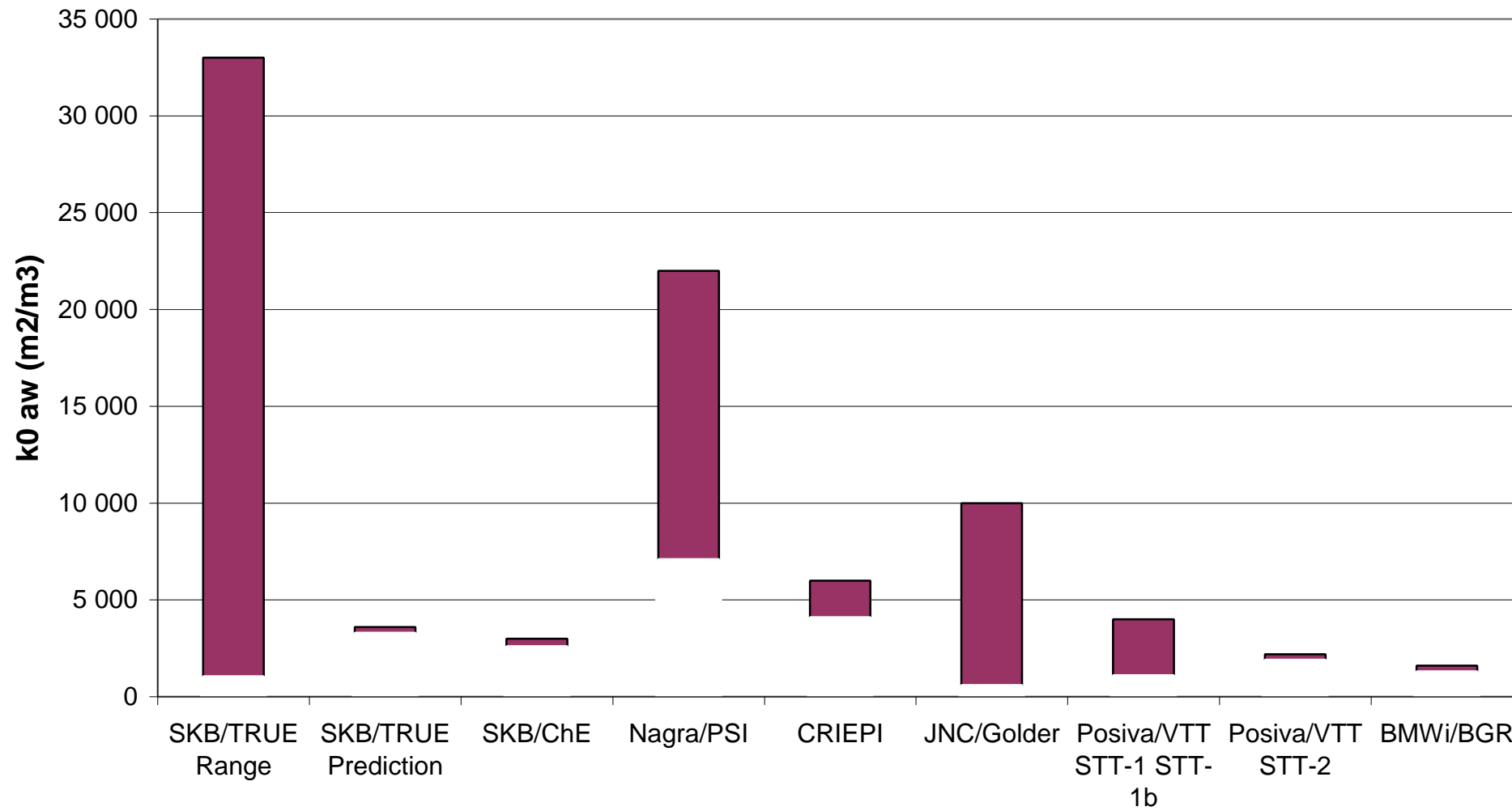
- Darcy flow (head gradients - transmissivity/hydraulic conductivity)
- Advection
- Dispersion (presence of different flow paths/ dispersion coefficient)
- Surface sorption
- Matrix diffusion and sorption
- Diffusion into fault gouge
- Diffusion into stagnant zones

# Model parameters

---

- Hydrology
  - Transmissivity - conductivity      Site characterisation / drawdown previous tests
  - Correlation length      *Preliminary tracer test*
  - Fracture aperture      Non-sorbing tracer BTC
  - Boundary conditions      Constant head 10-15 m from site
- Transport
  - Water residence time - Flow velocity      Hydraulic model/Non-sorbing tracer BTC
  - Dispersion      Non-sorbing tracer BTC
  - Flow path dimensions      Various methods
  - Surface sorption      Batch sorption experiments
  - Matrix diffusivity      Laboratory measurements
  - Matrix sorption      Batch sorption experiments

## Flow-wetted surface per volume of water





# Model calibration and development

---

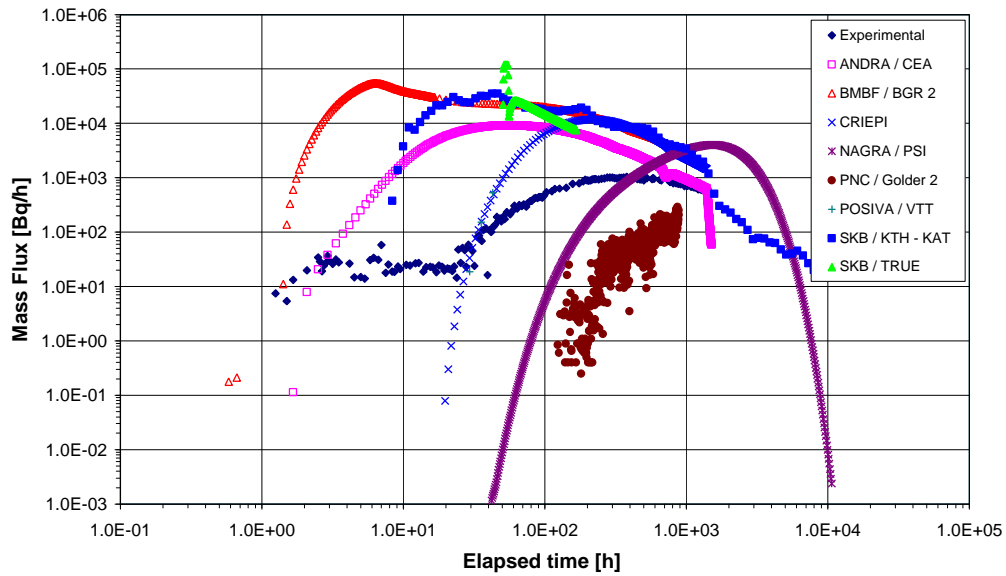
- Calibration to Preliminary Design Tests (PDT1-4) Non-sorbing tracers
- Updated structural model (Task 4F)
- Enhanced matrix diffusion needed to describe observed tailing.
- Retardation of sorbing radionuclides underestimated with laboratory data

# Modifications made for sorbing tracers

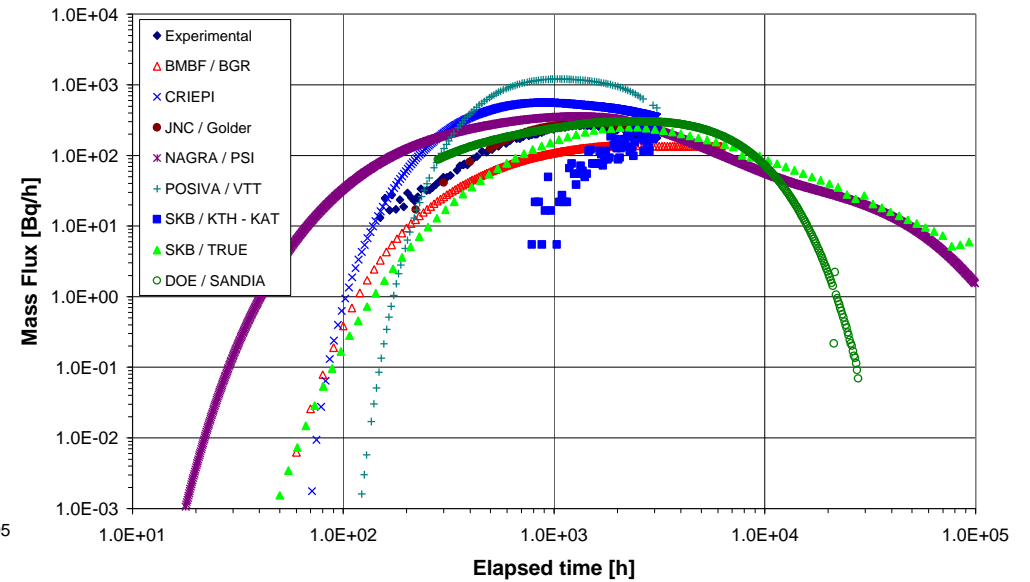
	ANDRA CEA	BMW BGR	CRIEPI	DOE Sandia	JNC Golder	NAGRA PSI	POSIVA VTT	SKB/KTH- ChE	SKB/KTH- TRUE
<b>STT-1</b>	Surface sorption Matrix diffusion	Sorption on fracture material	Surface sorption		Surface sorption	Surface sorption Diffusion & sorption fault gauge	Surface sorption Matrix diffusion	Matrix diffusion	Surface sorption (matrix diffusion)
<b>STT-1b</b>		+ Matrix diffusion	Increased $K_a$		+ Matrix sorption 2 pathways	+Diffusion in cataclasisite 2 pathways Adjusted $D_p$ , $K_a$ , $K_d$	Diffusion into stagnant zones	Increased $K_d * D_e$	+ Diffusion into fault gouge & stagnant water
<b>STT-2</b>	Increased $D_e$ & specific surface	Increased $K_a$ , $K_d$	+ Matrix diffusion Adjusted $K_a$ , $K_d$	Total capacity for mass transfer from STT-1	Adjusted $K_d$ Stagnant zones 9 pathways	Adjusted diffusivities and $K_d$	Adjusted $K_d$ , $K_a$ Channels with varying velocity	Reduced flow rate in flow path	Enhanced diffusion sorption factor

# Predictions Cesium STT-1 vs STT-2

STT-1 Cesium - Breakthrough in KXTT3 R2



STT-2 Cesium - Breakthrough in KXTT3 R2



# Methods to account for increased retardation

---

- SKB/TRUE
  - Rim zone with increased porosity
    - increased diffusivity
    - enhanced sorption
- SKB/KTH-ChE
  - Larger ratio: flow wetted surface/flow rate
    - uneven flow distribution around the extraction section
    - 3D flow field
- Nagra/PSI
  - Feature A a cluster of shorter interconnected fractures
  - Altered rock and fault gouge with increased porosity - diffusivity

# Lessons learned

---

- Experiment well characterised
  - flow rate measurements
  - resin injection -> spatial aperture distribution
  - diffusivity and sorption measurements on altered material
- Well conducted experiments
  - The long injection tail
  - High pumping rate gives short travel times
  - More rock interaction - slightly more sorbing tracers
- Evaluation
  - Post-prediction evaluation important
  - More use of Dirac source term
- Additional data and research
  - structural geology on the detailed scale
  - information on the flow wetted surface

# Conclusions

---

- Task 4E&4F has increased understanding of tracer transport in fractured rock
- A general consensus on the major transport processes
- Different ways of mathematical modelling applied with comparable results
- Transfer of laboratory data to field scale difficult
- Uncertainty in extrapolation to PA-scale

## Appendix C

[TRUE1 way forward](#)  
[A. Winberg \(Conterra\)](#)

# **Short status reports from TRUE Block Scale and Long-Term Diffusion Experiment**

**Anders Winberg, Conterra AB**

*15th Äspö Task Force Meeting  
Goslar, Germany, Sep 11-13, 2001*





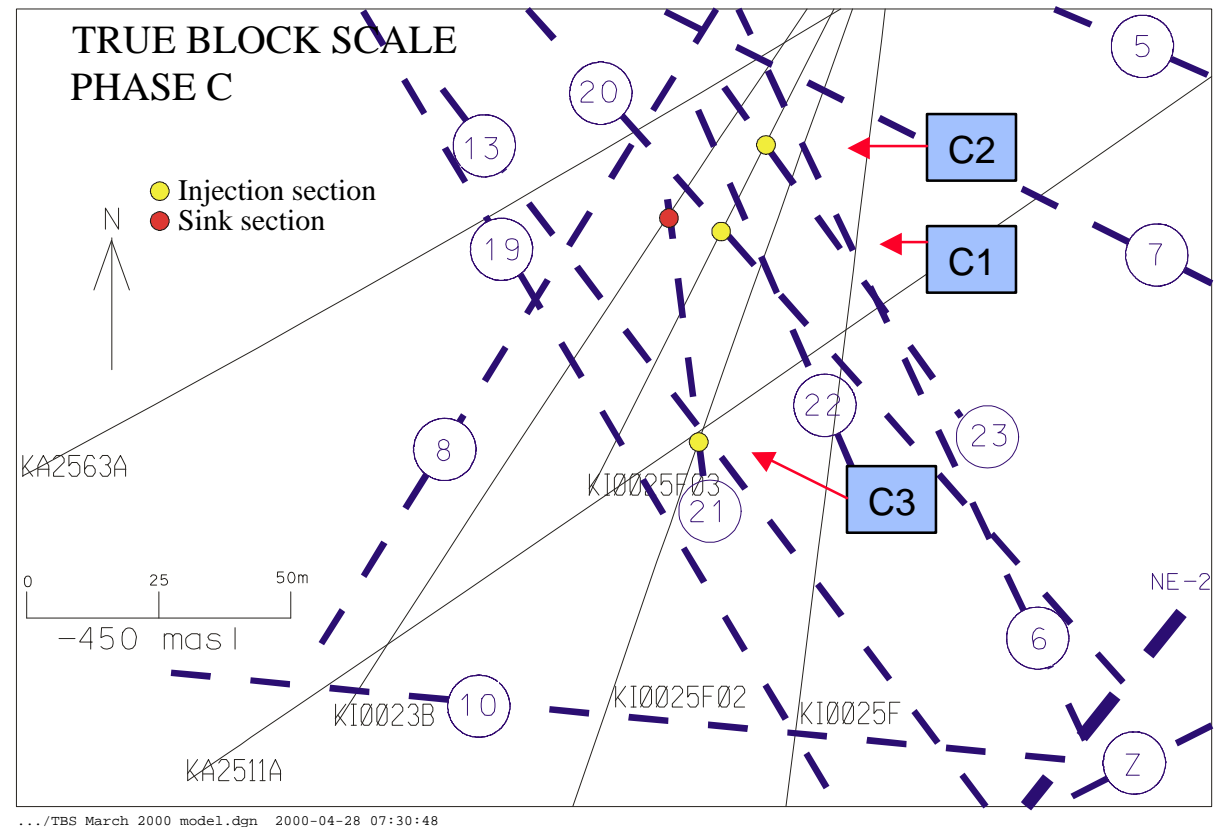
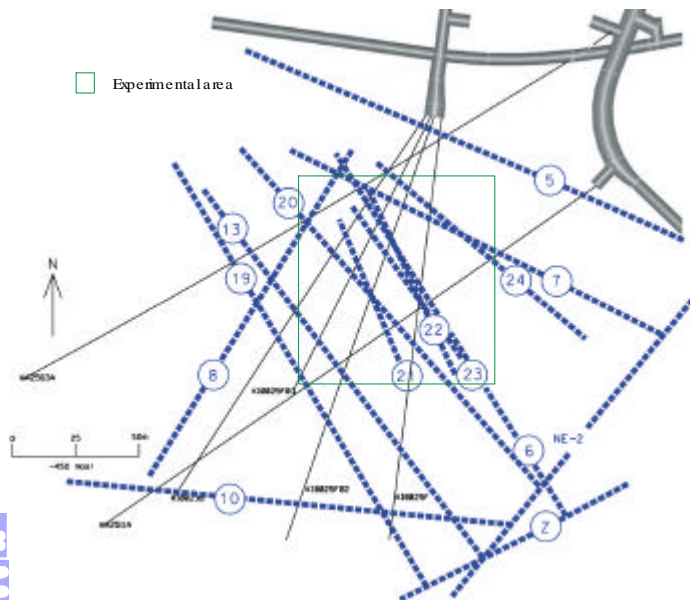
# TRUE Block Scale

## Overview of tracer test programme

### L =15-100 m

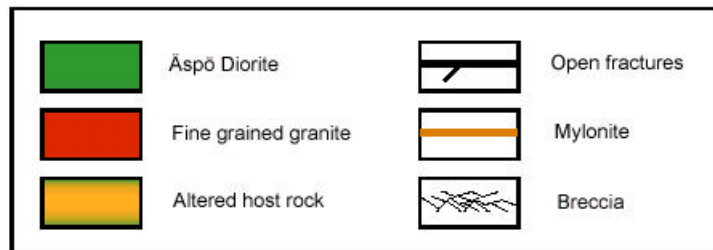
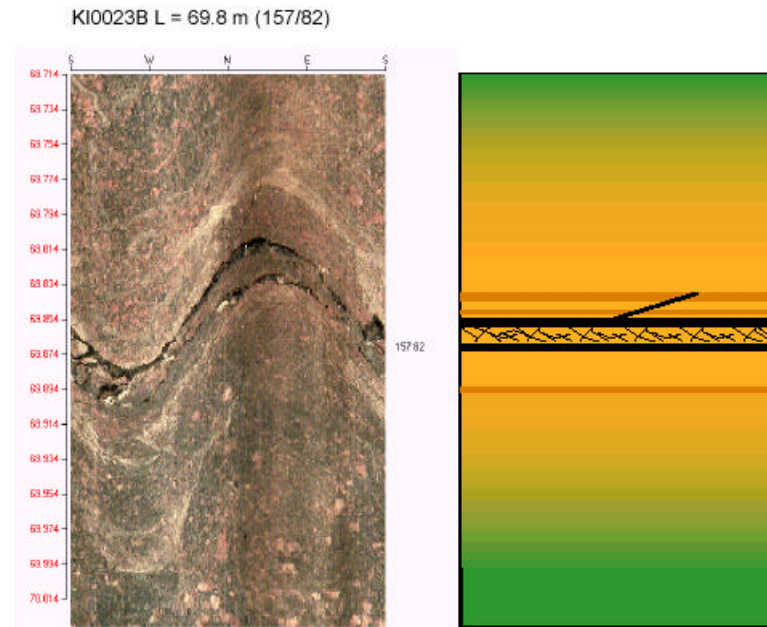
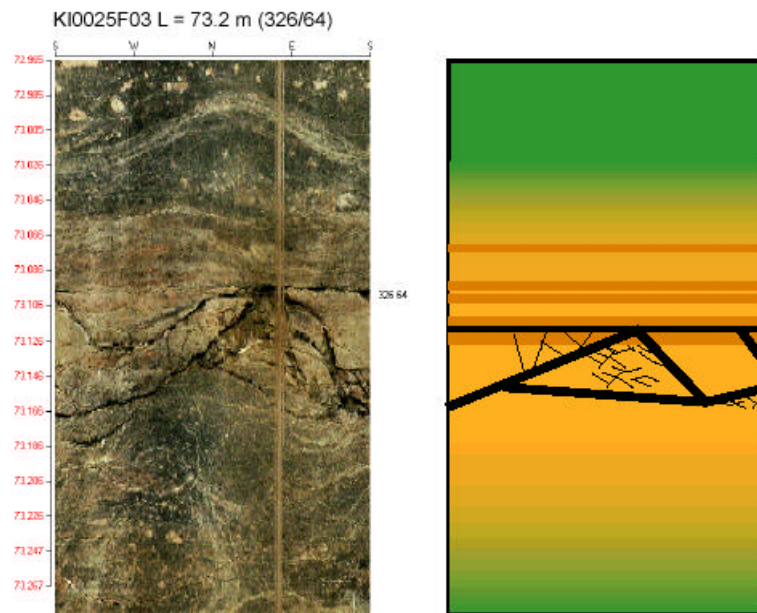
Phase C (Sorbing), Q=2.1 l/min

- C1 (L=16 m, 2 structures)
- C2 (L=97 m, > 3 structures)
- C3 (L=35 m, 1 structure)
- C4 (in C1 configuration)



# TRUE Block Scale

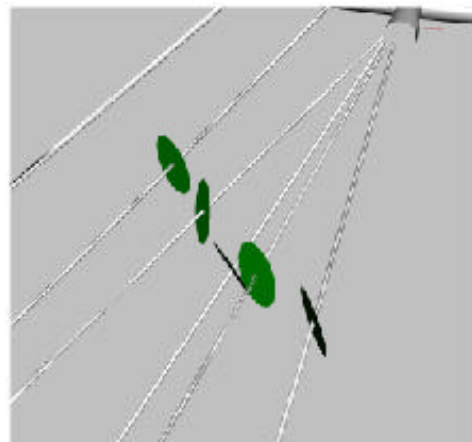
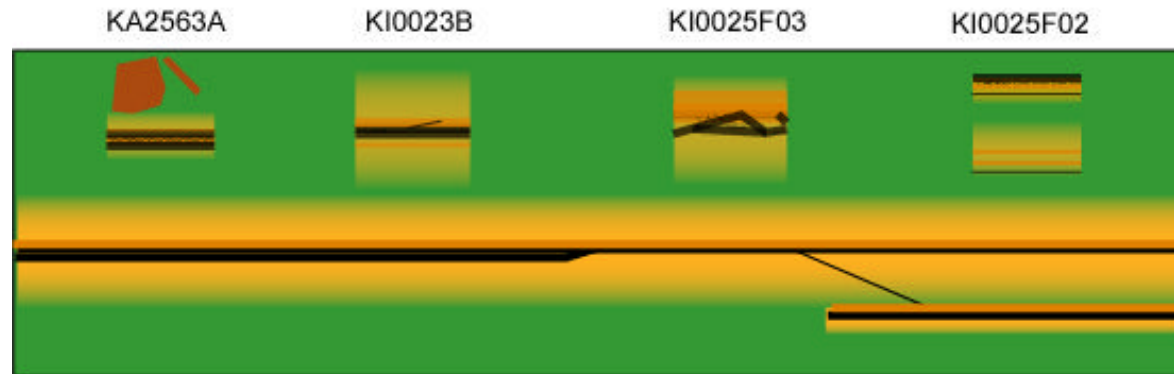
## Conceptual models of structure intercepts, #20



# TRUE Block Scale

## Integrated conceptual model of Structure #20

Conceptual illustration of structure #20



Structure #20 is characterised by a main fault with brecciation between minor fault planes. The structure is a reactivated mylonite with extensive cataclastic deformation and chemical alteration around the structure. The conductive pathway along this structure is likely to involve splay fractures. Fault gouge and fault breccia exists. The characteristics are similar to structure #13.



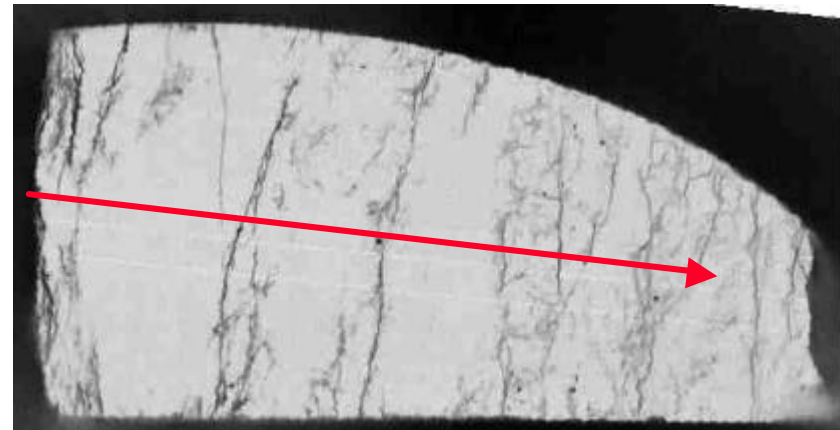


# TRUE Block Scale Porosity - $^{14}\text{C}$ PMMA

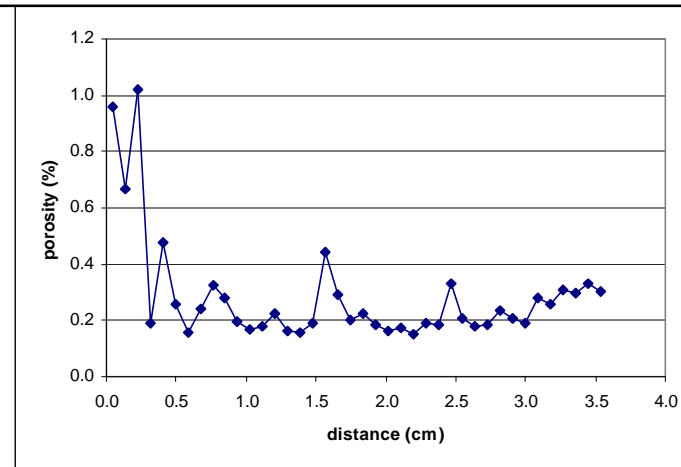
- Repeated impregnation, variable exposure times
- **Wall rock : #20, #21, #22, #23**
- **Pieces : #20, #22**
- **Fragments : #20, #22**
- $^3\text{H}$ -labelled MMA used for some fragment samples (low beta energy (18 keV))

## *Results :*

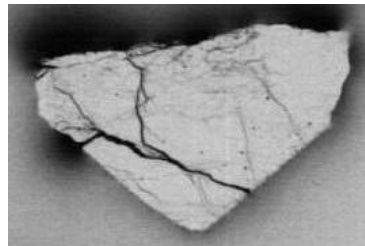
- **Fragments : #22: 1.3-11%, #20: 2-6%**
- **Pieces : #22:0.4-0.8% (high = 8-9%, #20:0.6-0.8% (high=10%))**
- **Wall rock : Similar porosity as seen for "pieces"**



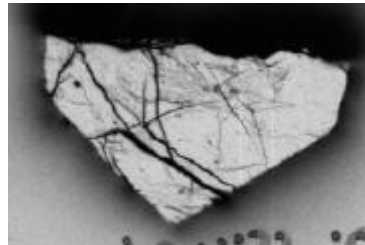
Wall rock, Structure #20, KI0025F02



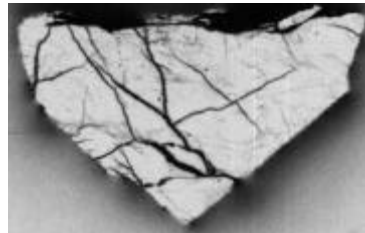
# TRUE Block Scale PMMA Autoradiographs - Breccia piece (#20)



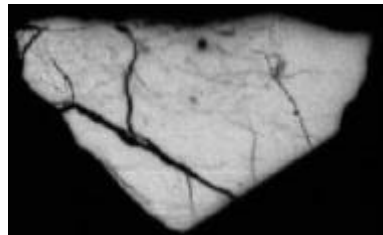
Piece A  
Surface B  
9 days exposure time  
width of sample 2cm



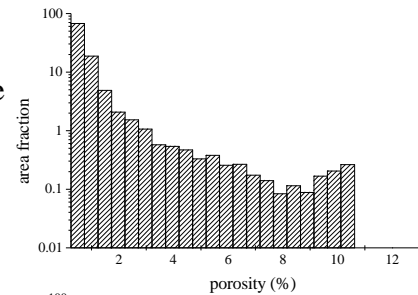
Piece A  
Surface C  
9 days exposure time



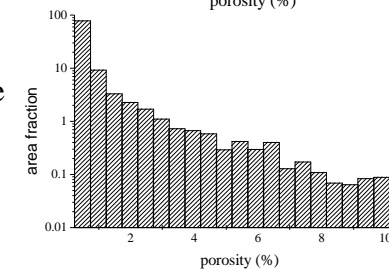
Piece A  
Surface E  
9 days exposure time



Piece A  
Surface F  
7 days exposure time



Surface C  
Total porosity of 0.8 %

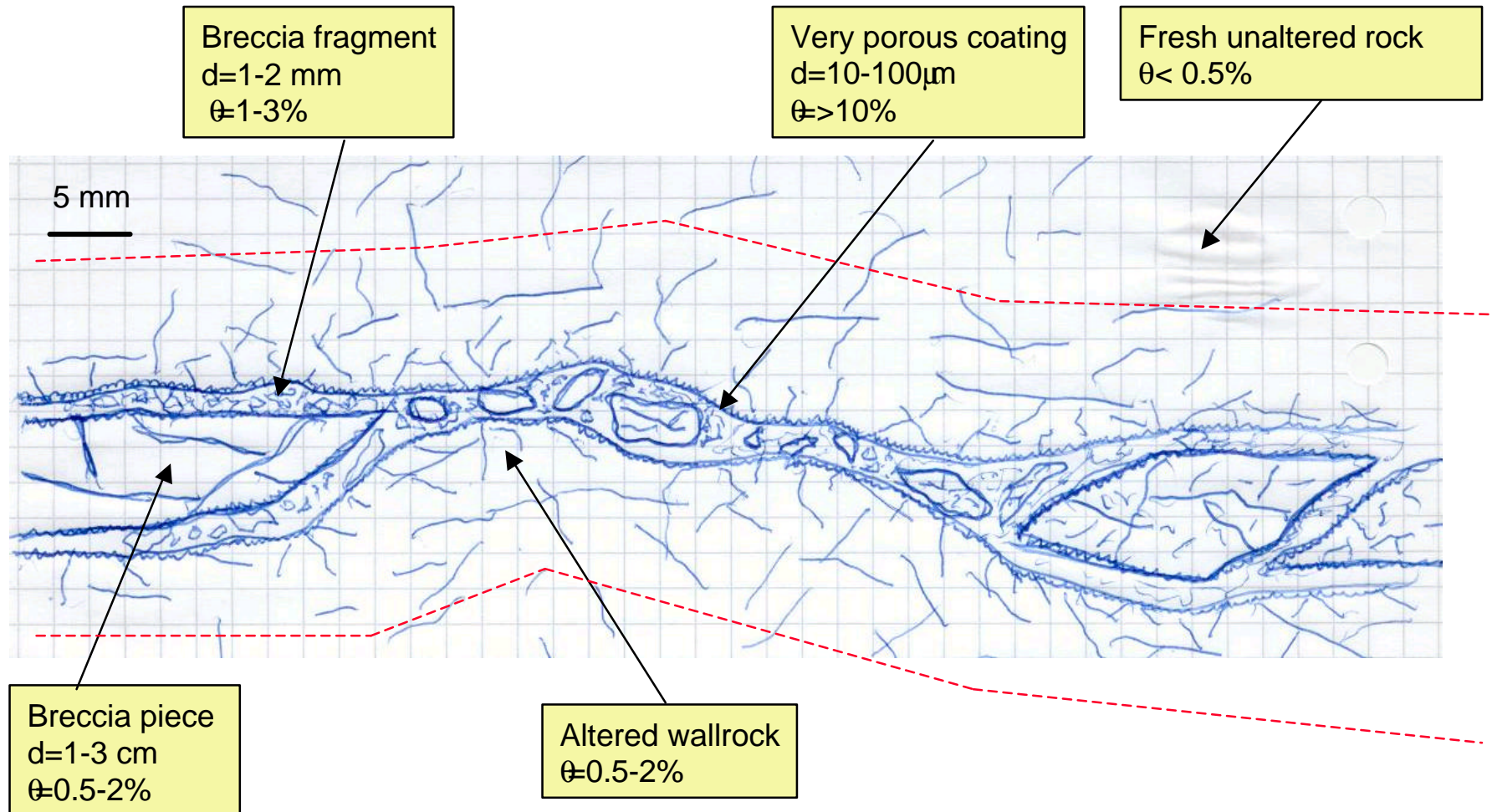


Surface E  
Total porosity of 0.6 %

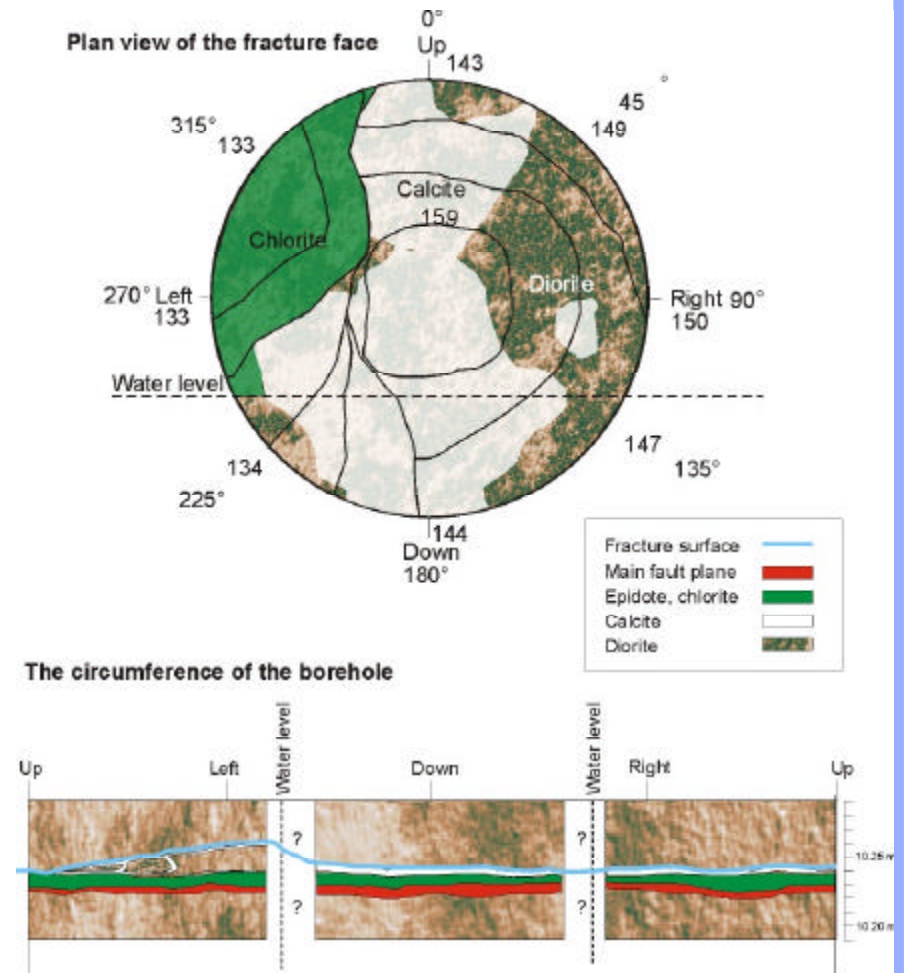
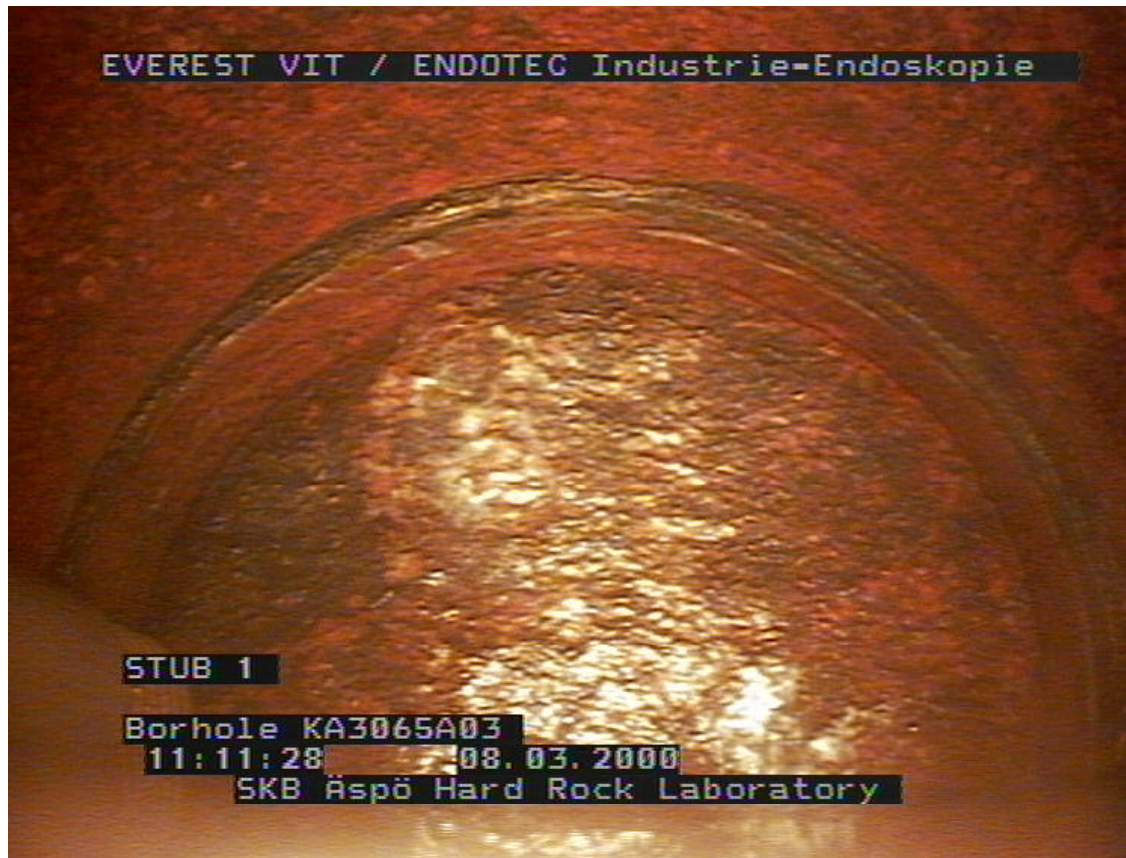
***Kemppainen et al., in prep.***

# TRUE Block Scale

## Preliminary conceptual illustration of a conductive structure involved in the tracer tests



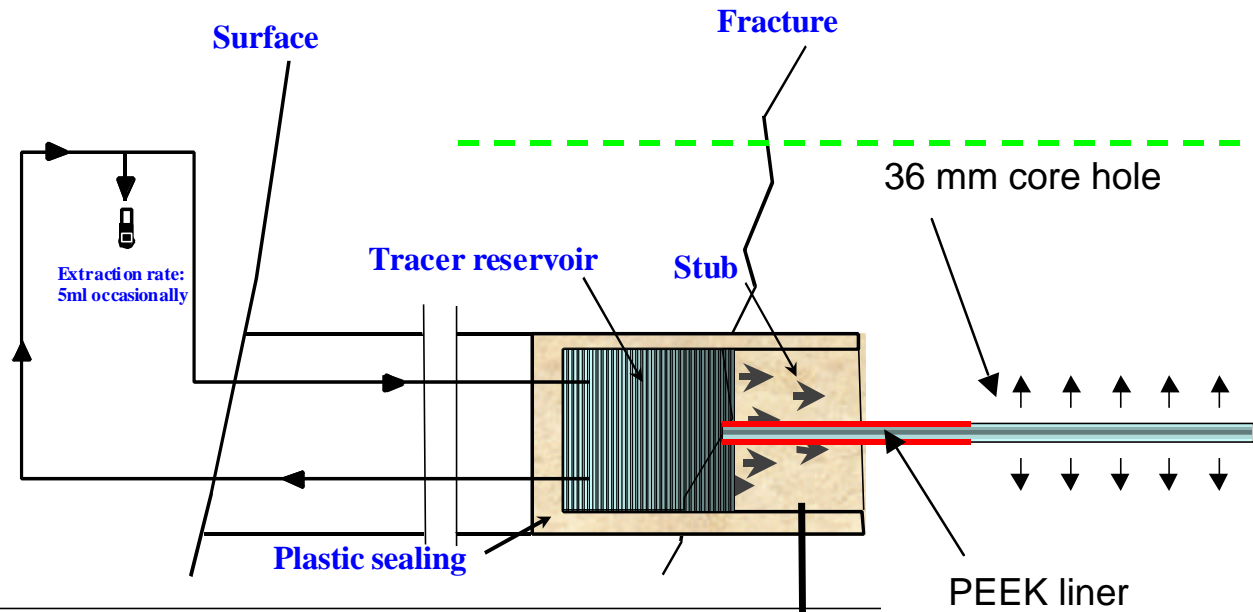
# Long term Diffusion Experiment Imaging of 177 mm stub in KA3065A03





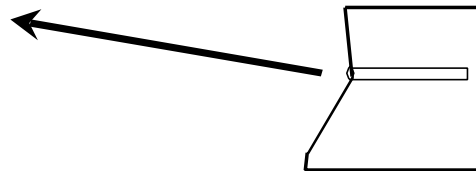
# Experimental concept

*In-diffusion phase, 0-4 years*



*Extraction of the stub, after 4 years*

Sample drilling, slicing,  
grinding, leaching,  
dissolution (method  
depending on tracer)



Tracer concentration  
measurement (method  
depending on tracer)

**LTDE  
Modified  
experimental  
concept**

# **TRUE Continuation**

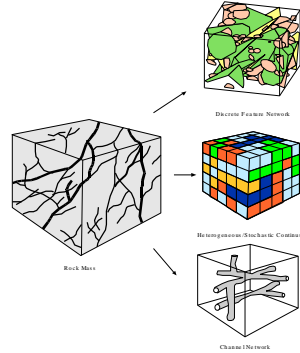
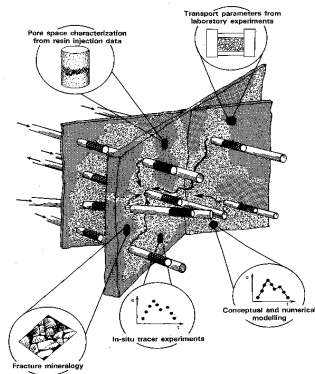
**Proposed plans for complementary work at the TRUE-1 site**

**Anders Winberg, Conterra AB**

*15th Äspö Task Force Meeting  
Goslar, Germany, Sep 11-13, 2001*



Complexity/costs



**Remaining issues (TRUE-1):**

- Flow path geometry/pore space
- Transport properties along flow path
- Transport parameters of rim zone

**TRUE-1**

- Single fracture
- Retention
- Role of rim zone
- Limited site-specific laboratory transport data

**Remaining issues (TRUE BS) :**

- Variable recovery
- Cataloguing of flow paths
- Stagnant water zones
- Transport properties along flow path (and in stagnant water zones)

**TRUE Block Scale**

- Successful characterisation of large rock block
- Quantification of matrix diffusion and sorption effects on a larger scale
- Demonstration/quantification of tracer retention in the block scale

~~**TRUE BS 3**~~

- ~~• Ramp tunnel to area of interest~~
- ~~• Additional borehole/s~~
- ~~• Complementary cross-hole tests and tracer injections~~
- ~~• Extension of tunnel into area of interest~~
- ~~• Epoxy resin injection~~

**BS 2c**

- Remediation of KI0023B
- Complementary cross-hole tests
- Complementary tracer tests

**BS 2b**

- Complementary tracer injections in existing array
- Alternative tracers (gas experiment?)
- Additional study of single features
- Critical geologic element for flow and transport and its parameters

**BS 2a**

- Continued monitoring of tracer breakthrough
- Porosity determinations
- Improved understanding of flow paths

Time



# TRUE Continuation

## General objectives, 1(2)

- **Demonstrate and validate a process for defining the critical geologic element/-s for flow and transport/retention and their transport properties,**
  - *Observations in TRUE possible to generalise for PA purposes?!*
  - *Short-term tests to obtain WL/q!*
- **Define, at different scales, the pore space (responsible for/necessary to explain) transport, diffusion, sorption and loss of tracer,**
  - *Matrix diffusion seen or not in experiments?!*
  - *Long-term properties of intact rock/altered rim zone!?*

# TRUE Continuation

## General objectives, 2(2)

- **Integrate experimental results from the laboratory, detailed scale and block scale to obtain a consistent and adequate description of transport to serve as a basis for modelling transport from canister to biosphere,**
  - *How valid are available laboratory data?!*
  - *Can we use the available laboratory data?!*
  - *Need for data on gouge material (fault breccia/fault gouge)?!*

# TRUE Continuation

**”One project, ... several experimental front lines!”**

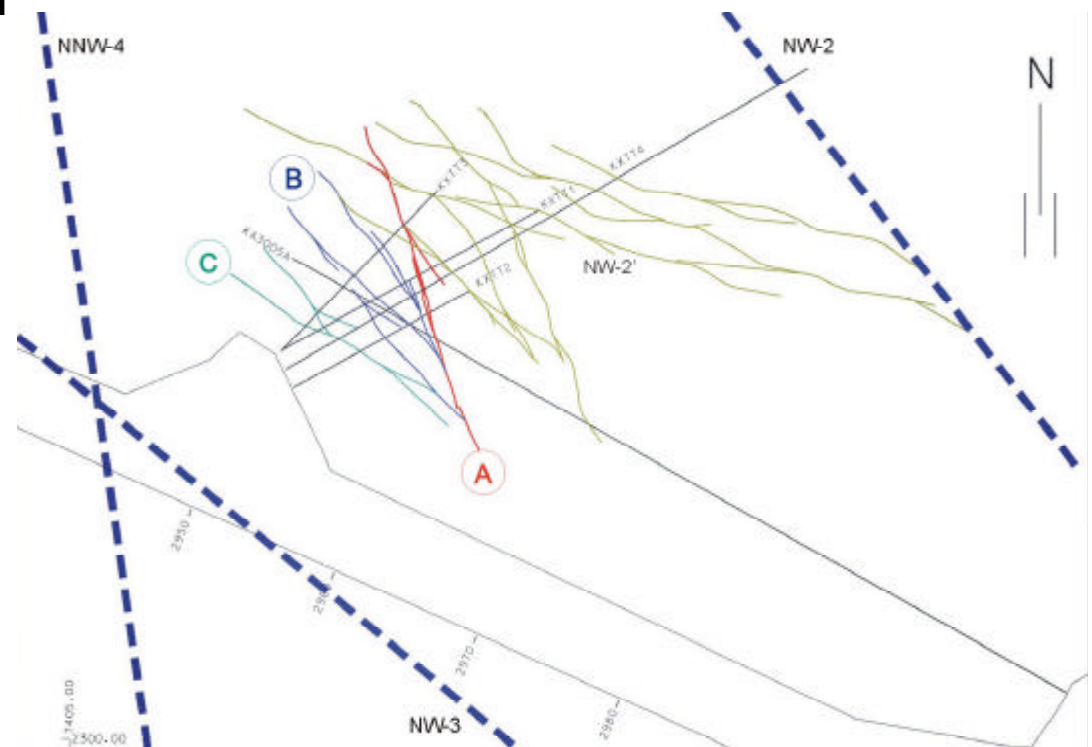
- **TRUE Block Scale**
  - **BS2a - Complementary modelling**
  - **BS2b - *In situ* experimental work followed by evaluation**
  - **Updating of conceptual models**
- **TRUE-1**
  - **Complementary *in situ* experimental work**
  - **Refinement of resin injection methodology**
  - **Resin injection, excavation and analysis**
  - **Updating of conceptual models**

# TRUE Continuation

## Complementary tests at the TRUE-1 site

### Proposed objectives

- Obtain insight into the internal structure of the investigated Feature A to allow resolve of the pore space providing the noted retention in the performed experiments,
- Provide insight into the three-dimensionality of the studied rock block as part of the First TRUE Stage such that the role and effects of the fracture network connected to Feature A on the performed tracer tests can be assessed,



# **TRUE Continuation**

## **Complementary tests at the TRUE-1 site**

### **Feature A specific issues**

- 1 Can the double peak in the breakthrough curve noted for STT-2 be fully attributed to the two fracture intercepts observed in KXTT4:R3, or does the double peak emanate from other internal features/effects?**
- 2 Assessment of the noted factor 1.3-2.2 higher retention for the more strongly sorbing radionuclides, when comparing STT-1 and STT-2. Related either to stronger diffusion/sorption along the flow paths invoked during STT-2, evolving chemistry (less saline groundwater) and/or the lower transport velocity (50% reduction in pump rate)?**



# TRUE Continuation

## Complementary tests at the TRUE-1 site

### Feature A and its relation to the surrounding fracture network

#### 3 Connectivity between Feature A and the more complex Feature B?

*The two features are interpreted to intersect in the vicinity of boreholes KXTT2 and KA3005A.*

#### 4 Connectivity between Feature A and Feature NW-2'.

*These features are interpreted to intersect in the vicinity of borehole KXTT3,*

*The above issues can be addressed by running experiments (**tracer dilution experiments at ambient/pumped conditions**) with new source-receiver combinations, **selected tests driven to breakthrough**.*

*Of particular interest is to assess singularity of Feature A by making use of source-sink pairs located in the same borehole.*

# TRUE Continuation

## Complementary tests at the TRUE-1 site

### Evolution of "Global effects" and its impact on transport in Feature A

- 5 Development of the distribution of **hydraulic head** as a function of time, and its effect on transport/retention in Feature A.
- 6 Development of **groundwater flow** (as determined by inflow to section/-s of the access tunnel) as a function of time, and its effect of transport/retention in Feature A.
- 7 Development of **groundwater chemistry** as a function of time, and its effect of transport/retention in Feature A.

*Compilation of evolution in above parameters compiled in a report by Källgården et al., in prep.*

# TRUE Continuation

## Complementary tests at the TRUE-1 site

### Fracture aperture ( $^{222}\text{Rn}$ ) and Colloid transport

#### Assessment of fracture aperture using measurements of radon content in the groundwater :

- 8 Assessment of possibility to use a combination of radon content in the groundwater and measurements of radon flux from TRUE-1 bedrock to provide estimates of fracture aperture (*this aperture also theoretically linked to  $a_w$* ),

**NOTE : Assessment of  $2b$  and  $q$  (tracer dilution) will be obtained from corresponding sections.**

#### Measurement of colloid transport in a fracture :

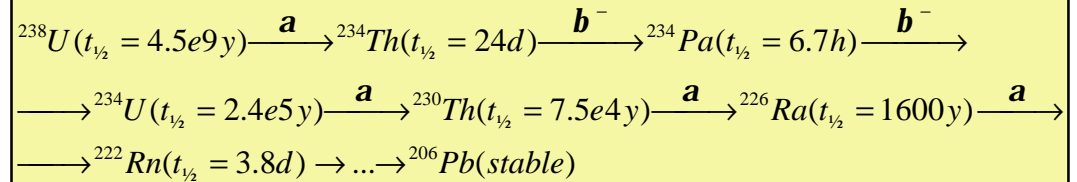
- 9 *In situ* experimentation of transport of artificial colloids in a natural fracture (COLLOID, Laaksoharju (2001).

*Postponed awaiting results of planned in situ chemical reactor experiments*

# TRUE Continuation

## Use of radon data for aperture estimations from Byegård (in prep)

- An equilibrium concentration will be obtained when the numbers of radon atoms diffusing into the fracture per unit time is equal to the numbers of radon atom decayed per unit time.
- The equilibrium concentration of radon in the fracture will depend on:
  - Concentration and spatial distribution of  $^{226}\text{Ra}$  in the rock matrix
  - Diffusion rate of the radon atoms in the rock matrix
  - Fracture aperture
  - Fracture hydraulics ( $q$ ,  $t_w$ )
- Dependence of  $[\text{Rn}]_{\text{aq}}$  on the  $[\text{U}]_{\text{rock}}$  (Eq. 1) (Andrews et al. 1991)
- Estimation of fracture aperture from saturation radon flux and radon concentration in groundwater (Eq. 2), Andrews et al. 1989.



$$[\text{Rn}]_{\text{aq}} = \frac{12.2Er[\text{U}]_{\text{rock}}}{e} \quad (\text{Eq. 1})$$

$$w = \frac{2F}{1000[\text{Rn}]} \quad (\text{Eq. 2})$$

Example based on TRUE-1 data :

$$w = 2b = 769 \mu\text{m}$$

$$\text{Assume plane-parallel fracture : } a_w = k = 2 \cdot (1/w) = 2600 \text{ m}^{-1}$$

Note : Escape of Rn by MD not accounted for.

# Aperture from $^{222}\text{Ra}$ - taking effects of matrix diffusion and exchange with matrix into account (Neretnieks, in press)

- Neretnieks has extended the model of Andrews et al. to also account for production within the matrix, and exchange between fracture and matrix (*to be presented at an IAH conference, Berkeley, March 2002*)
  - Consequence is that the apertures are 10-20% (Carmenellis) and a factor 5-10 (Stripa), respectively. Particularly important for smaller fractures.
  - Äspö example :  $c = 10^4$  Bq/l pore water (*at 30% efficiency*),  $[\text{Rn}] = 300-700$  Bq/l gives  $2b=100-200 \mu\text{m}$  ( $a_w = 1/b = 5000-10000 \text{ m}^{-1}$ ).

## Measurement of *in situ* CEC - Background

- Key radionuclide to investigate following resin injection and subsequent excavation is Cs-137,
- About 60% of the injected Cs is remaining in the fracture/injection section. Assuming a 5 cm wide flow path the projected present activity is about 20 kBq/cm<sup>2</sup> (as low as 20 Bq/cm<sup>2</sup> along the flow path),
- Difficult to use the remaining sorbed Cs-137 as a tool to map the surface area in the fracture,
- May be possible to saturate the cation exchange sites by injection of non-radioactive Cs in higher concentration,
- Use non-radioactive Cs as a tool to map the flow path after the excavation of the fracture,
- Injection of non-radioactive Cs, combined with studies of Cs-137 in the effluent may provide useful information on sorption /desorption mechanisms,
- Mass balance calculation would give an *in situ* CEC.

# **TRUE Continuation**

## **Complementary tests at the TRUE-1 site**

### **Measurement of *in situ* CEC**

- X Proposed procedure for measuring *in situ* CEC**
  - a Injection of desorption agent (preferably Cs, alternatively Co-hexamine or Ba) in successively increasing concentration. The water at the withdrawal borehole is analysed for its content of desorbing agent and desorbed tracer from the STT-1 and STT-2 experiments ( $^{137}\text{Cs}$  and  $^{134}\text{Cs}$ , respectively),**
  - b After the resin excavation at the TRUE-1 site has been performed, measurements of tracer distribution on the fracture surfaces can be performed. Any remaining radioactive Cs could be measured by  $\gamma$ -spectrometry, and the amount of desorption agent (stable Cs or Co-hexamine/Ba) is favourably measured using neutron activation analysis.**

# **TRUE Continuation**

## **Complementary tests at the TRUE-1 site**

### **Schedule (preliminary)**

#### **Schedules**

- **Complementary tests : June - Dec 2001**
- **Complementary laboratory investigations**
- **Resin technology development : Sep 2001- Jan 2003**
- ***In situ* CEC experiment : 2003/2004**
- **Resin injection/excavation/analyses : 2003/2004**
- **Results from resin injection : 2004/2005**



## **Appendix D**

### **Task 4 Overall Evaluation** **P. Marshall (NAGRA)**

---

# Overall evaluation of the modelling of the TRUE-1 tracer tests - Task 4

Mark Elert & Paul Marschall

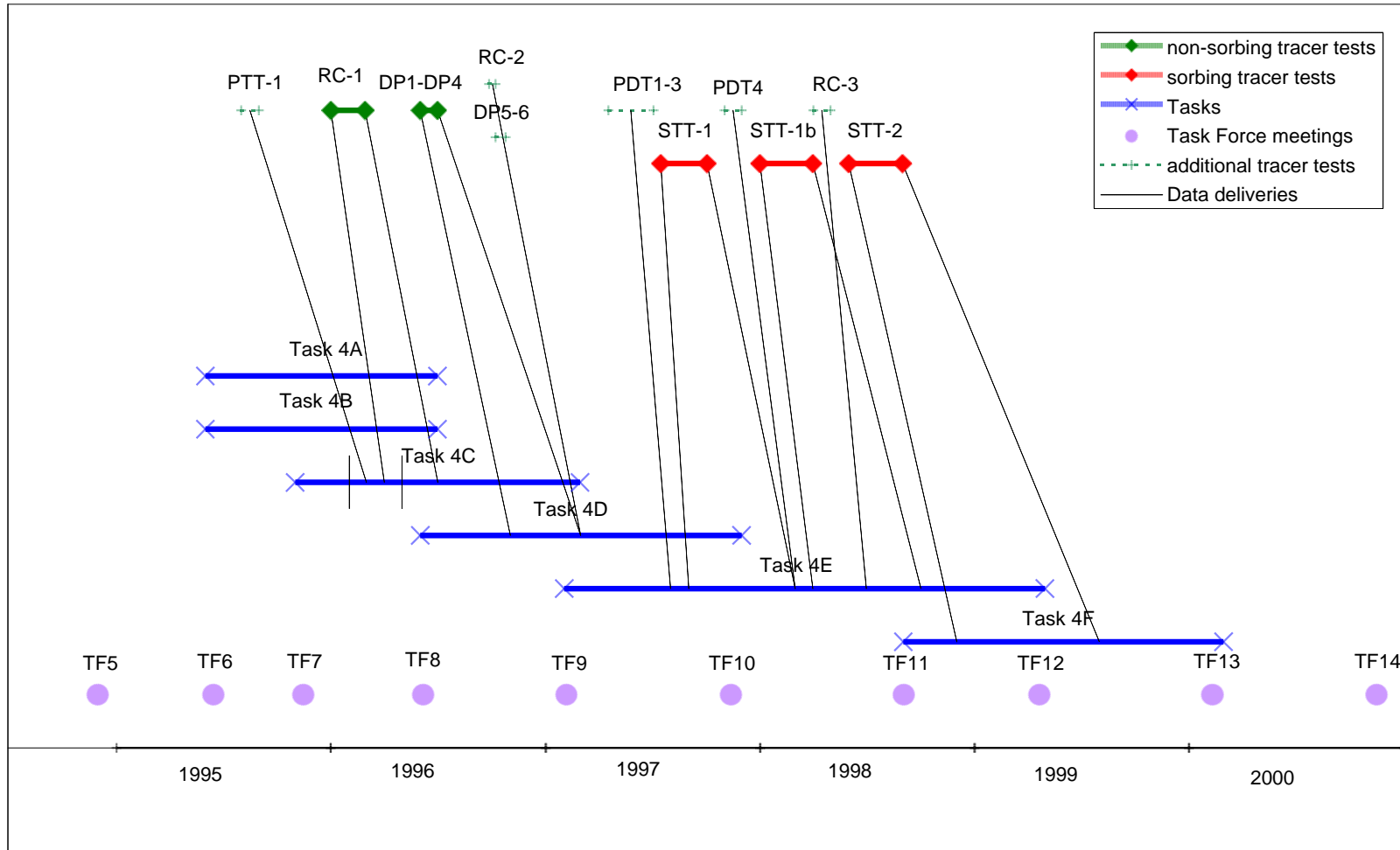
15th Task Force Meeting in Goslar, September 2001

---

**Kemakta Konsult AB**



# Overall evaluation Task 4 (Chapter 2: Task history)



# Overall evaluation Task 4 (Chapter 1: Introduction)

---

- Motivation and Expectations

## Viewpoint of the Task Force Delegate:

- ⇒ How did the **level of conceptual understanding** of solute transport in the TRUE site change in the course of Task 4 and which were the **most successful stages**?
- ⇒ Was there any valuable impact of Task 4 modelling results on the **design of the TRUE** field experiments?
- ⇒ Which of the **site characterisation** data improved conceptual understanding of flow and transport processes in the site?
- ⇒ Which conclusions can be drawn with respect to the suitability of the wide range of **codes** and **model concepts**?
- ⇒ Which of the **steering tools** applied through Task 4 (questionnaires, blind predictions, performance measures, etc.) are recommended for **future modelling tasks**?

# Overall evaluation Task 4

---

## Evaluation Issues proposed at the brainstorming Meeting TF#14 in Gothenborg

- Methodologies for tracer test interpretation/analysis
- Achievements in development of modelling tools
- Evaluation of important SC data
- Role of modelling resources ("cost / benefit")
- Feedback by modellers to SC groups
- Evolution of experimental and modelling ambitions
- Evolution of the TRUE experiment
- Most beneficial stages in the task evolution
- Evolution of the conceptual model
- Interaction between experimental and modelling groups
- Aspects of steering a modelling task (interaction among modellers)
- Assessment of publication strategy
- Relevance of flow model / microstructural models and processes
- Evolution of SC focus / Optimisation of SC strategy
- Transfer of evidences / parameters / methodologies to other sites ("effective properties"), robustness of statements
- The role of modelling workshops / interaction between modellers
- Transfer of understanding to other tasks (Task 5)
- Shortcomings from experimental set-ups (input pulse)
- Data deliveries (operation of interface SC/modellers/information overload)

# Overall evaluation Task 4 (Chapter 3: Evaluation Issues)

---

- Areas of interest
  - assessment of **conceptual understanding** of transport processes with focus on PA-requests (chapter 3.2);
  - achievements in tracer test interpretation / **tool development** (chapter 3.3);
  - assessment of steering tools as part of the **task management** (chapter 3.4)

# Overall evaluation Task 4 (Chapter 3: Evaluation Issues)

---

- Conceptual understanding of transport processes

The agreed procedure was to decompose the problem:

- understanding of **groundwater flow** in a complex hydrogeological environment (Task 4 A - D)
- understanding of **transport mechanisms** (Task 4D - F)

- Evaluation criteria / Definition of „level of understanding“:

Plausibility: The results of a conceptual / numerical model are plausible, if they do not contradict general hydrogeological experience. This level of understanding does not allow any kind of model discrimination ("Which model is better?")

Consistency: If model results are consistent with independent evidences, confidence in general system understanding will increase.

Quantitative performance: If the model output matches in a satisfactory way a quantitative performance measure, a certain amount of confidence in model predictions will be given

# Overall evaluation Task 4 (Chapter 3.2: Groundwater flow)

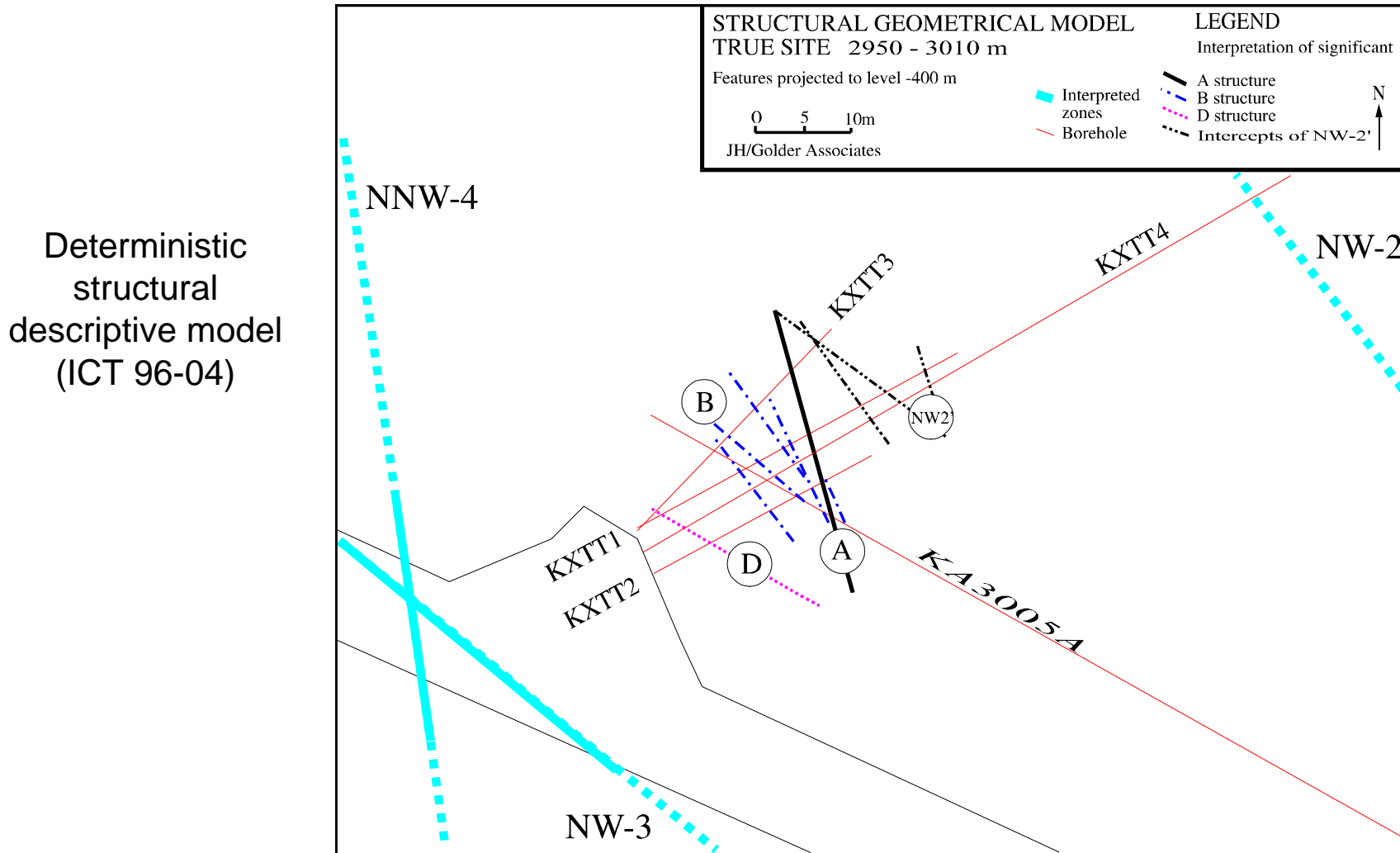
- Which site characterisation data improved significantly the level of understanding?  
(++ suitable for model discrimination, + consistency of conceptual assumptions, o plausibility)

Method	Purpose	Data used by:	Relevance
<b>Early stage of TRUE-1 site characterisation (before packer emplacement)</b>			
Structural Investigations - tunnel mapping, geophysical surveys - borehole logging - core mapping	- fracture / rock classification - fracture statistics (orientation, frequency, width, trace lengths)	PNC/Golder	++
Geochemical Investigations - groundwater sampling - rock samples	- fracture / rock classification	-	o
Hydraulic Investigations - Flow logging - Single hole packer tests	- Fracture transmissivity	CRIEPI, PNC/Golder, SKB KTH-ChE, POSIVA, SKB-TRUE, Nirex, AEA	++
<b>TRUE-1 site characterisation after packer emplacement</b>			
Hydraulic Interference Tests	- transmissivity distribution & hydraulic connectivity (- hydraulic boundary conditions)	PNC/Golder, SKB-TRUE	++
Long-term Monitoring of Head	- hydraulic boundary conditions	PNC/Golder, SKB-TRUE, CRIEPI, POSIVA	+
Solute Tracer Tests (RC1)	- consistency check / system understanding	all groups	+



# Overall evaluation Task 4 (Chapter 3.2: Groundwater flow)

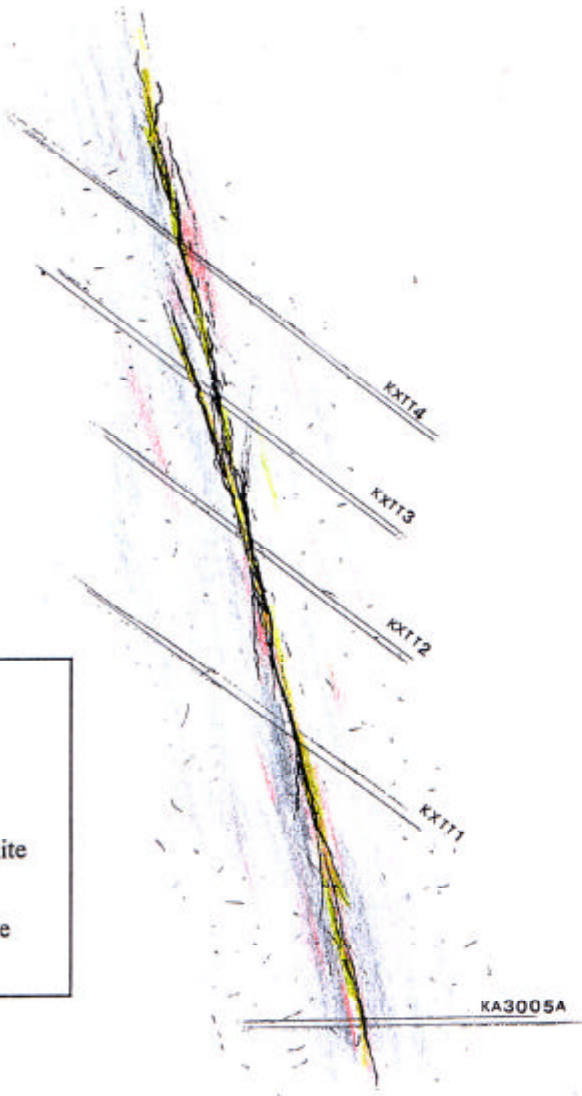
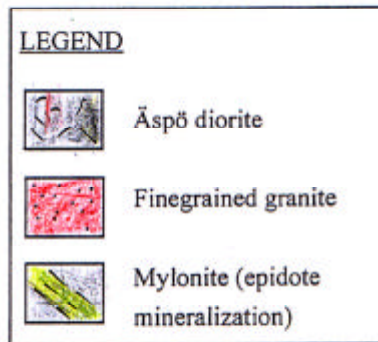
- Structural descriptive model at the end of Task 4B: TRUE-1 site



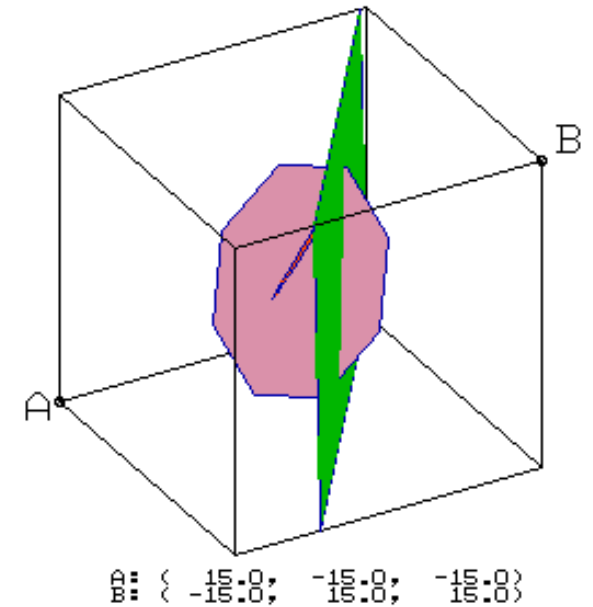
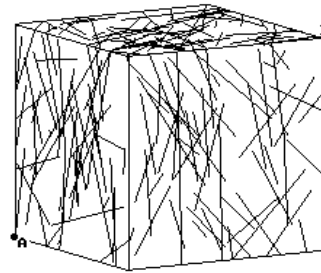
# Overall evaluation Task 4 (Chapter 3.2: Groundwater flow)

- Structural descriptive model at the end of Task 4B: Target Feature A

Deterministic structural descriptive model (ICT 96-04)



Stochastic structural descriptive model (ICT 96-05)



Both models were consistent within the geoscientific data base, available before packer emplacement

...but: lack of information on spatial continuity

# Overall evaluation Task 4 (Chapter 3.2: Groundwater flow)

---

- Consistency of the Task 4 A/B structural descriptive model with crosshole data
  - instrumentation of the boreholes was based on the structural descriptive model of the early TRUE-1 site characterisation work
    - ⇒ packer positions fixed according to the spatial definition of Features A-D
    - ⇒ risk of distortion of natural groundwater flow by short circuiting through b.h.
  - further site characterisation after site instrumentation (interference tests, longterm monitoring of head, tracer tests)
    - ⇒ lack of reciprocity in interference tests
    - ⇒ „cross-talks“ between the different features (interference tests)
    - ⇒ strong hydraulic responses in far distant boreholes
    - ⇒ no recovery in some of the pilot tracer tests

Significant discrepancies between observations and model results despite the vast amount of SC data

# Overall evaluation Task 4 (Chapter 3.2: Groundwater flow)

---

- Understanding of groundwater flow in the TRUE-1 site / **Conclusions**
  - The conceptual descriptive model of the TRUE-1 site was largely derived from geological and hydraulic borehole data. Subdivision of the inventory of structural elements in **4 more or less independent planar features was to some extent arbitrary**, nevertheless plausible from a geological perspective.
  - The **instrumentation of the site** was designed on the basis of the **pre-mature structural model**. Particularly, the spatial continuity of the features and possible interconnectedness were still unknown.
  - Hydraulic **interference tests** and tracer tests showed to be **suitable for validation** of the conceptual model. Major inconsistencies were identified.
  - Interference tests could have been used for refinement of the conceptual descriptive model.

⇒ More insight by arrangement of site instrumentation?

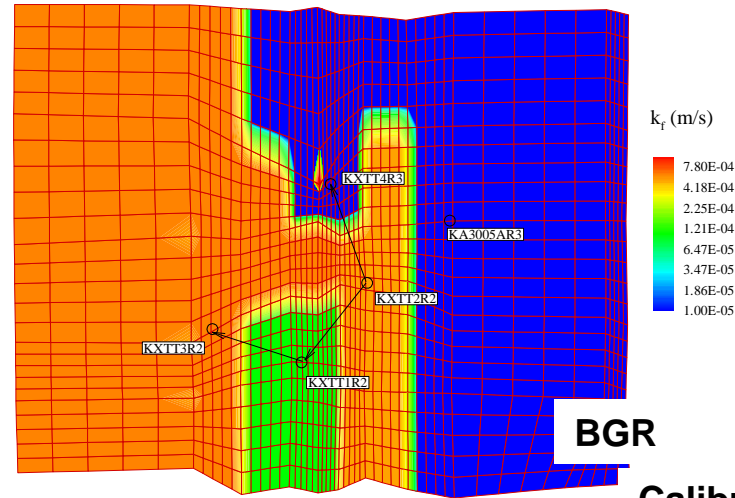
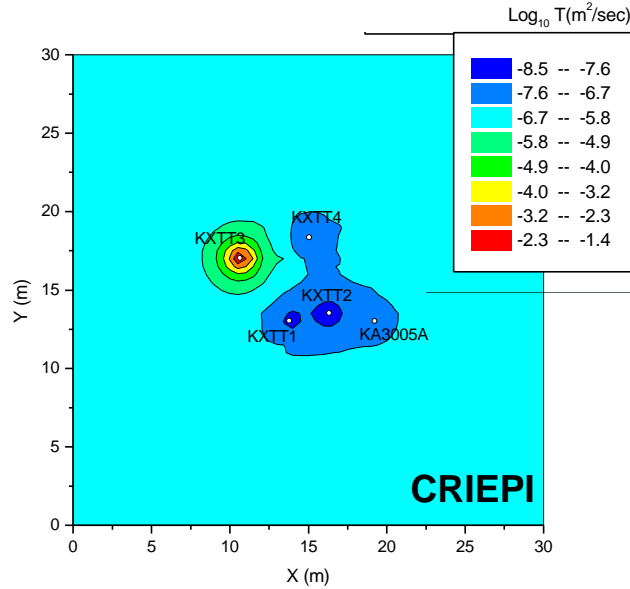
# Overall evaluation Task 4 (Chapter 3.2: Groundwater flow)

- Assessment of modelling tools / Convergence of modelling approaches
  - wide spectrum of models
  - only 2 of them could address 3-D flow conditions

Team	Model Type	Dimensions
CRIEPI	Deterministic / stochastic continuum	2-D
PNC/Golder(II)	Deterministic continuum / Fracture network	2D / 3D
SKB KTH-ChE	Channel network	3D
POSIVA/VTT	Stochastic continuum	2D
BMWI/BGR	Deterministic continuum	2D
SKB KTH-TRUE	Stochastic continuum	2D
Andra	Analytical model	2D
Nirex/AEA	Stochastic continuum	2D

# Overall evaluation Task 4 (Chapter 3.2: Groundwater flow)

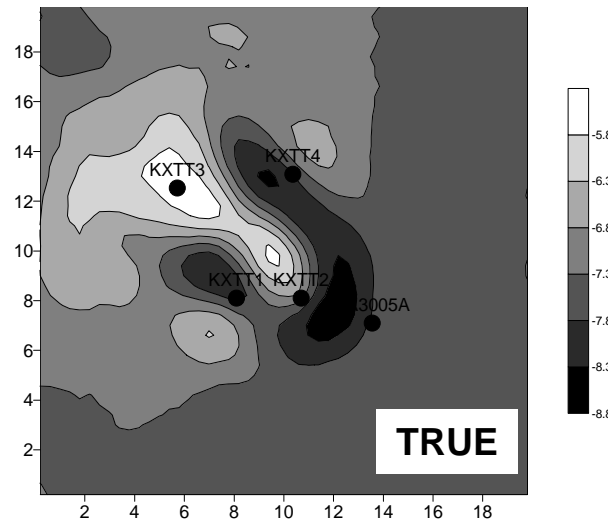
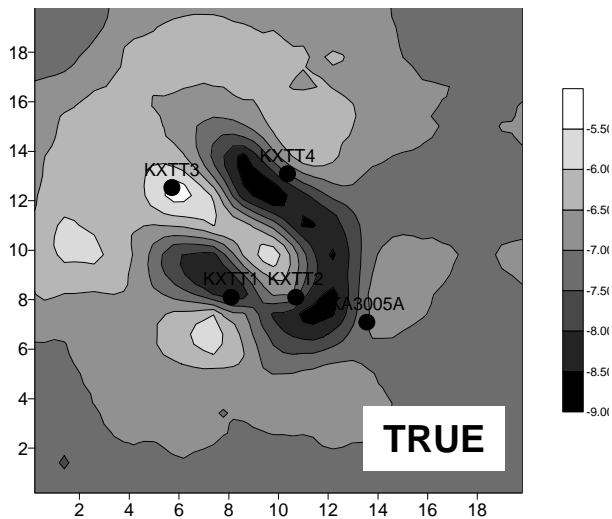
- Assessment of modelling tools / Convergence of modelling approaches



Calibration / conditioning on RC1:

- no significant differences in model performance
- some of the drawdowns were not well matched

(... All models were plausible, but not consistent ...)



# Overall evaluation Task 4 (Chapter 3.2: Groundwater flow)

---

- Assessment of tools / Convergence of approaches - **Conclusions**
  - inherent restrictions of the 2-D models - dimensionality of flow could not be fully assessed (use of “leakage” concepts, ...)
  - performance of most of the models was comparable.
  - wide spectrum of K-distributions, considerable degree of uncertainty concerning the role of boundary conditions
  - the DFN approach seems to be most promising for model analysis (test of hypotheses) and for model refinement

# Overall evaluation Task 4 (Chapter 3.2.3: **Transport**)

---

- Understanding of transport mechanisms in the TRUE-1 site

... Not yet done

- Assessment of tools / Convergence of approaches

....



# Overall evaluation Task 4 (Chapter 3.2.4: Interpretation)

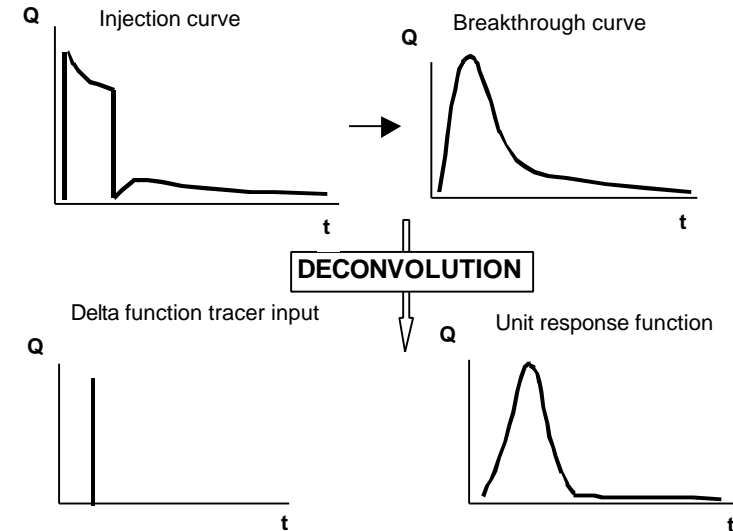
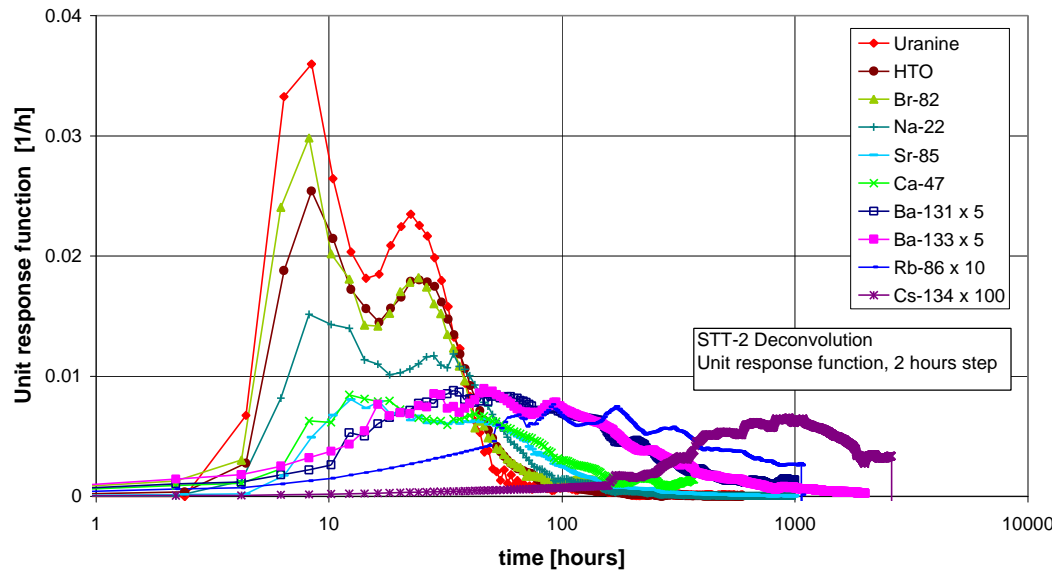
---

- Highlights in methodology development
  - Analysis of groundwater flow: Dershowitz / Cherbourg
  - Interpretation of non-reactive / reactive tracer tests: Cvetkovic
  - Deconvolution approach

# Overall evaluation Task 4 (Chapter 3.2.4: Interpretation)

- Deconvolution approach

- high potential for diagnostic tracer test analysis
- gives insight into “information content” of unit response function



- Unresolved issues

- instability problems at high sampling rates
- possible noise amplification due to truncation errors, noise in data, ...

⇒ further developments  
are recommended

# Overall evaluation Task 4 (Chapter 3.2.5: **Steering Aspects**)

---

- Assessment of steering aspects
  - The role of TF-Meetings and reporting
  - Prediction / Evaluation Tasks, performance criteria
  - Questionnaires, external advisors, ...
  - Recommendations

... not yet done

# Overall evaluation Task 4

---

<b>1</b>	<b>Introduction</b>	<b>0</b>
1.1	Background and scope	0
1.2	Objectives	0
→ 1.3	Expectations of the participating organisations	0
<b>2</b>	<b>Task 4 - Overview</b>	<b>0</b>
2.1	Overview of the TRUE-1 project	0
2.2	Task concept	0
2.3	Aims and overview of subtasks within Task 4	0
2.4	Modelling groups and approaches applied	0
2.5	Task history	0
<b>3</b>	<b>Evaluation Issues</b>	<b>0</b>
3.1	Areas of interest and evaluation approach	0
3.2	Conceptual understanding of transport processes in the TRUE-1 site	0
3.2.1	Background and evaluation issues	0
3.2.2	Understanding of groundwater flow in the TRUE-1 site	0
3.2.3	Understanding of transport mechanisms	0
3.2.4	Interpretation methodologies	0
3.2.5	Steering aspects	0
<b>4</b>	<b>Conclusions and outlook</b>	<b>0</b>
4.1	Conclusions	0
4.2	Outlook	0
<b>5</b>	<b>References</b>	<b>0</b>

**Contributions received:**

**CRIEPI, Nagra,  
Sandia, SKB**

# Overall evaluation Task 4

---

- Milestones, Schedule and Responsibilities

Overall Evaluation Task 4		
Action	deadline	Resp
Proposed report outline (extended outline)	end Nov.00	Mlp/ME
Review of report outline	end Dec.00	TF-D, MG
Statements by the participating organisations	end Mar.01	TF-D
Chapters 1-2: First Draft	Sept. 01	ME/Mlp
Chapter 3: Extended outline	Sept 01	Mlp/ME
Comments by TFD	mid Oct. 01	TF-D
First complete draft	end Nov 01	all
Review of draft report	end Dec01	
....		

## **Appendix E**

### **Summary report - Hydrology** **I. Rhén (SWECO)**

# Task 5 Summary Report

- Due to time constraints, the distributed Summary Report should be considered a rough draft
- Nevertheless it provides a detailed overview of the proposed lay-out
- Much work still remains to be done
- Some sections need to be shortened
- Other sections are incomplete and still others need to be rechecked for accuracy and misinterpretation
- All comments are welcome to facilitate completion of the report

# Task 5: Outline of Summary Report

- Chapter 1: Background
- Chapter 2: Geological and hydrogeological setting
- Chapter 3: Available sources of data
- Chapter 4: Modelling: Background perspective and Task 5 issues
- Chapter 5: Modelling: Application and results
- Chapter 6: Summary and overall conclusions
- Chapter 7: Acknowledgements
- Chapter 8: References
- Appendices 1-7



# Task 5: Available Sources of Data

- Pre-investigation Phase (1986-1990)
- Construction Phase (1990-1995)
- Operation Phase (1995-2050?)
- Task 5: First Working Group Meeting, October, 1997
  
- Considerable amount of available data:
  - Geological data
  - Hydrogeological data
  - Hydrochemical data (including M3)
- Evolution of conceptual ideas and models

# Task 5: Modelling: Background perspective and Task 5 issues

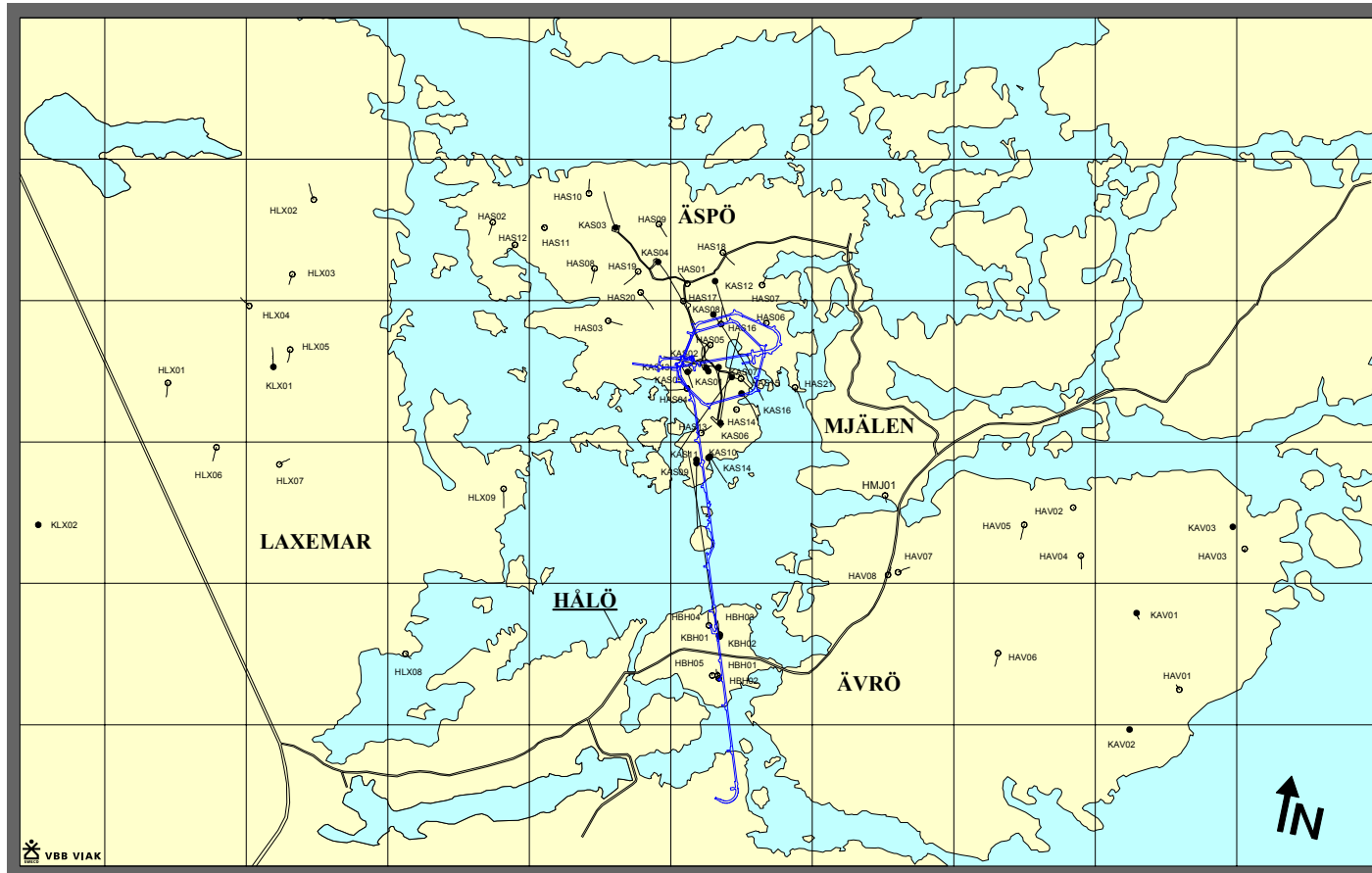
- **General modelling approaches available:**
  - hydrodynamic models (discrete fracture network; stochastic continuum; channel network etc.)
  - hydrogeochemical models (chemical reaction equilibrium/kinetic, coupled flow and reaction; mixing etc.)
- **Task 5 Modelling. Main objectives:**
  - to assess the consistency of groundwater flow models and hydrochemical mixing-reaction models through integration and comparison of hydraulic and chemical data obtained before and during tunnel construction
  - to develop a procedure for integration of hydrological and hydrochemical information which could be used for disposal site assessments

- **Task 5 Modelling. Performance measures:**
  - to facilitate comparison and integration of hydrological and hydrochemical, a series of control points were identified along the tunnel
  - based on these locations, a series of measures were identified to check the performance of the models:
    - the nature of the groundwater flow pattern through the bedrock to the tunnel control points
    - the advective groundwater travel time distribution to the control points, and
    - the nature of the groundwater chemical evolution to explain the results at each control point

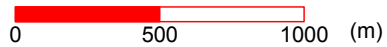
- **Task 5 Modelling. Aims:**

- model calibration along tunnel length 0-2900 m based on available data from the pre-investigation and construction phases
- model predictions of construction phase disturbance along tunnel length 2900-3600 m was based on inflow groundwater data from the entire tunnel section; no hydrochemical data were released

# Task 5: modelling area



VBB VIAK



/13080143/DATA/ÄSPO\_HRL.SRF 10/29/99

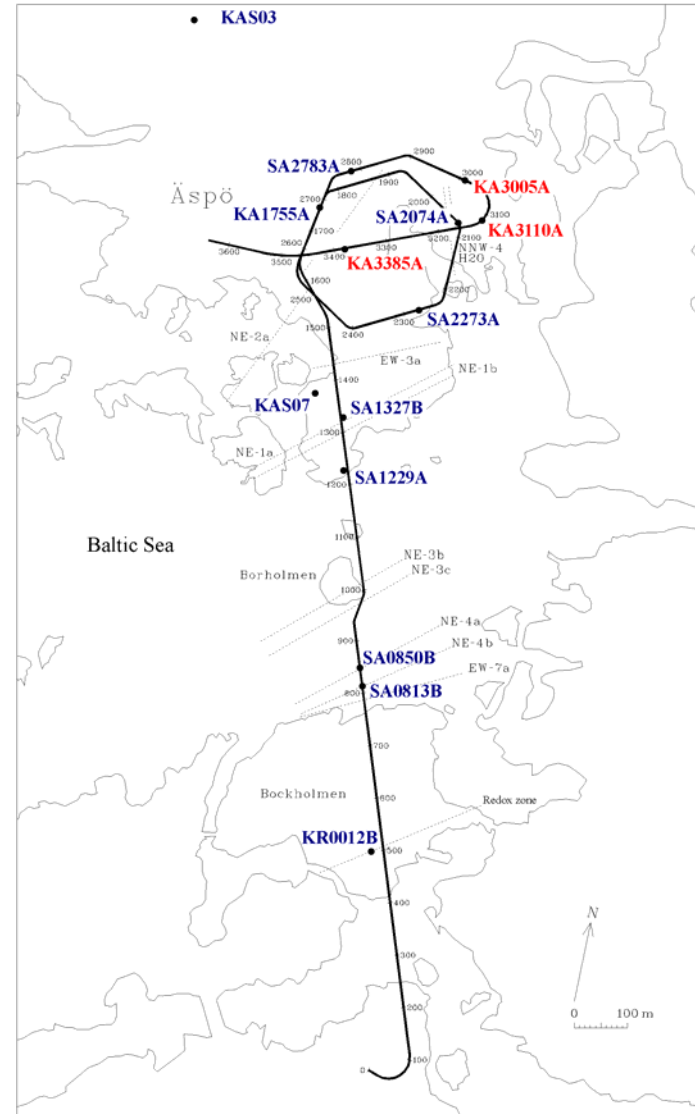


2001-09-13

Task 5. Task Force, Äspö HRL

# Control points

CONTROL POINTS LESS THAN 2900M  
CONTROL POINTS MORE THAN 2900M



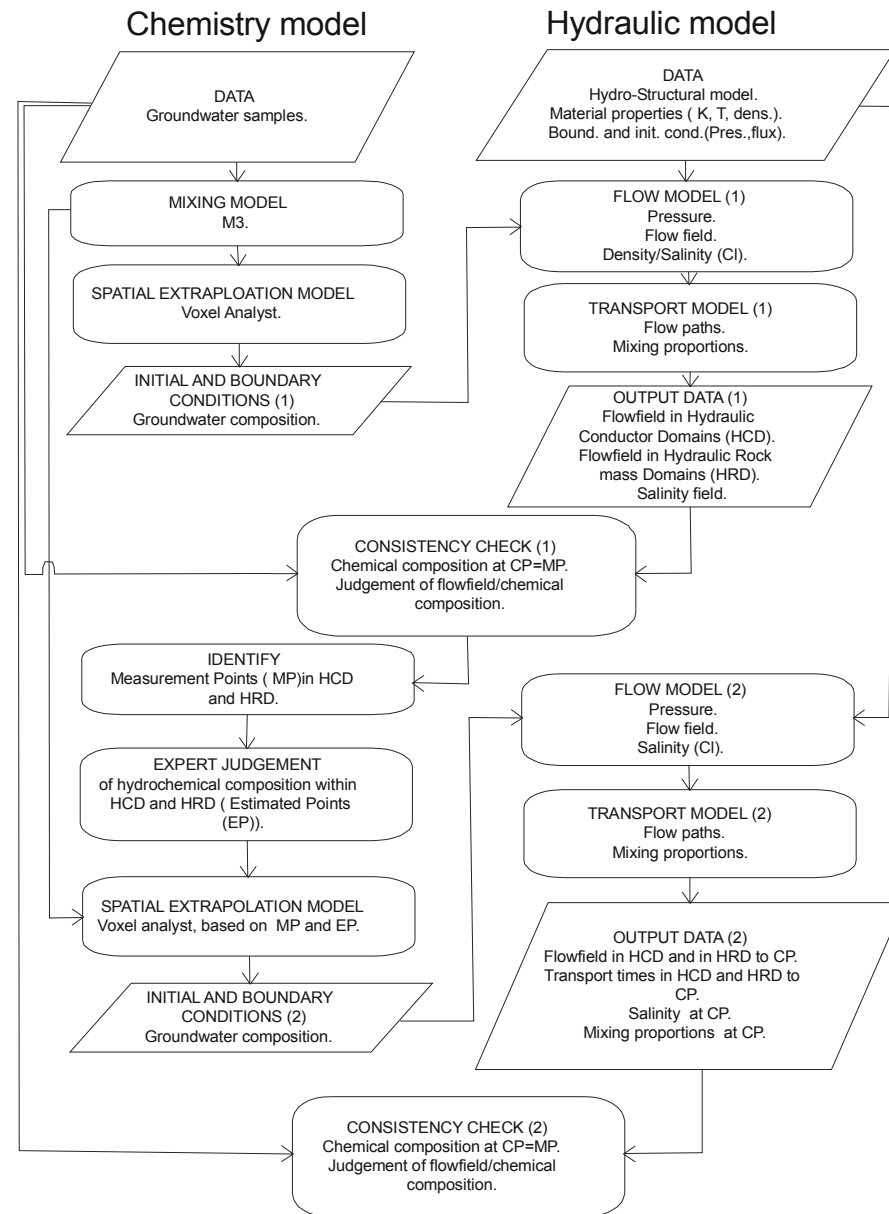
# Task 5: Hydrodynamic Modelling Approaches Applied by the Modelling Teams

# Task 5: Integration of Hydrodynamics and Hydrochemistry



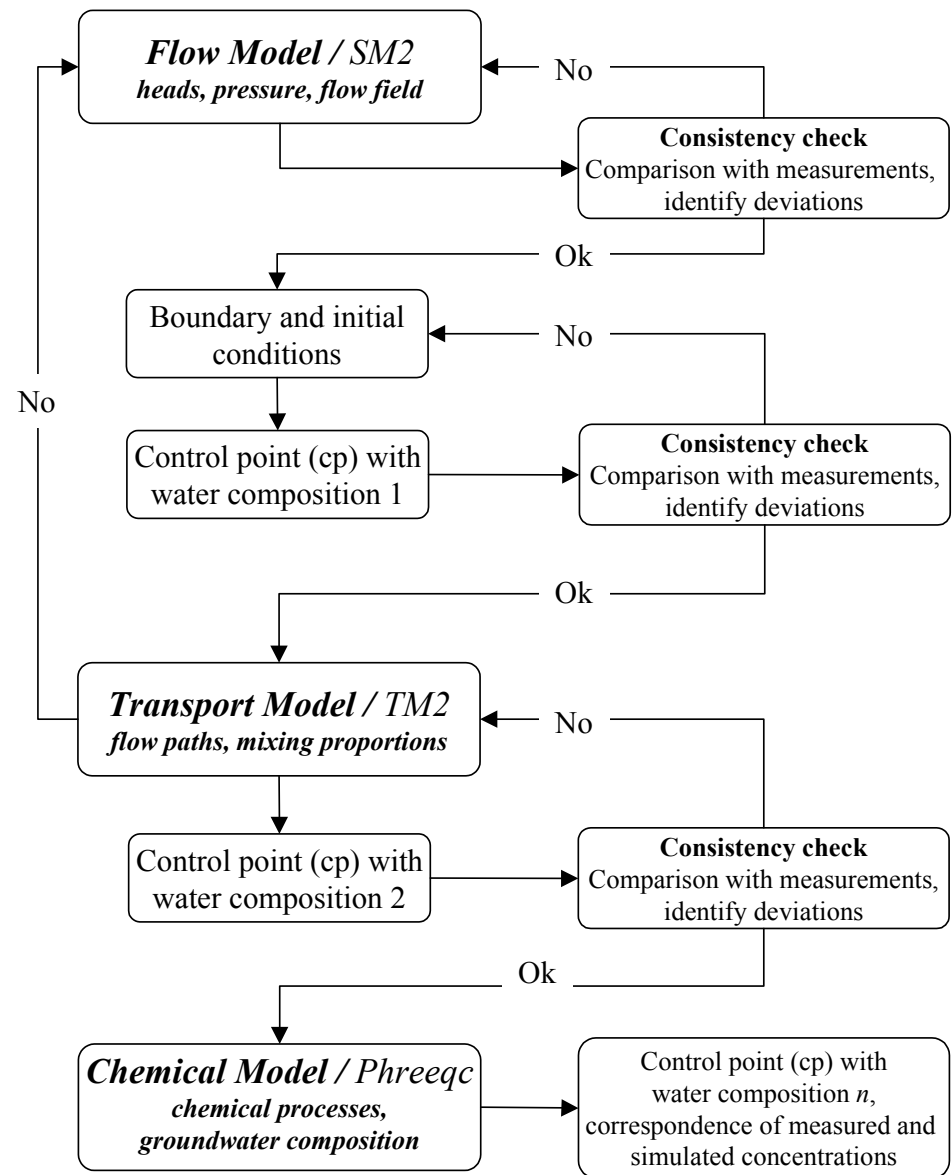
# Modelling steps used (1)

- SKB



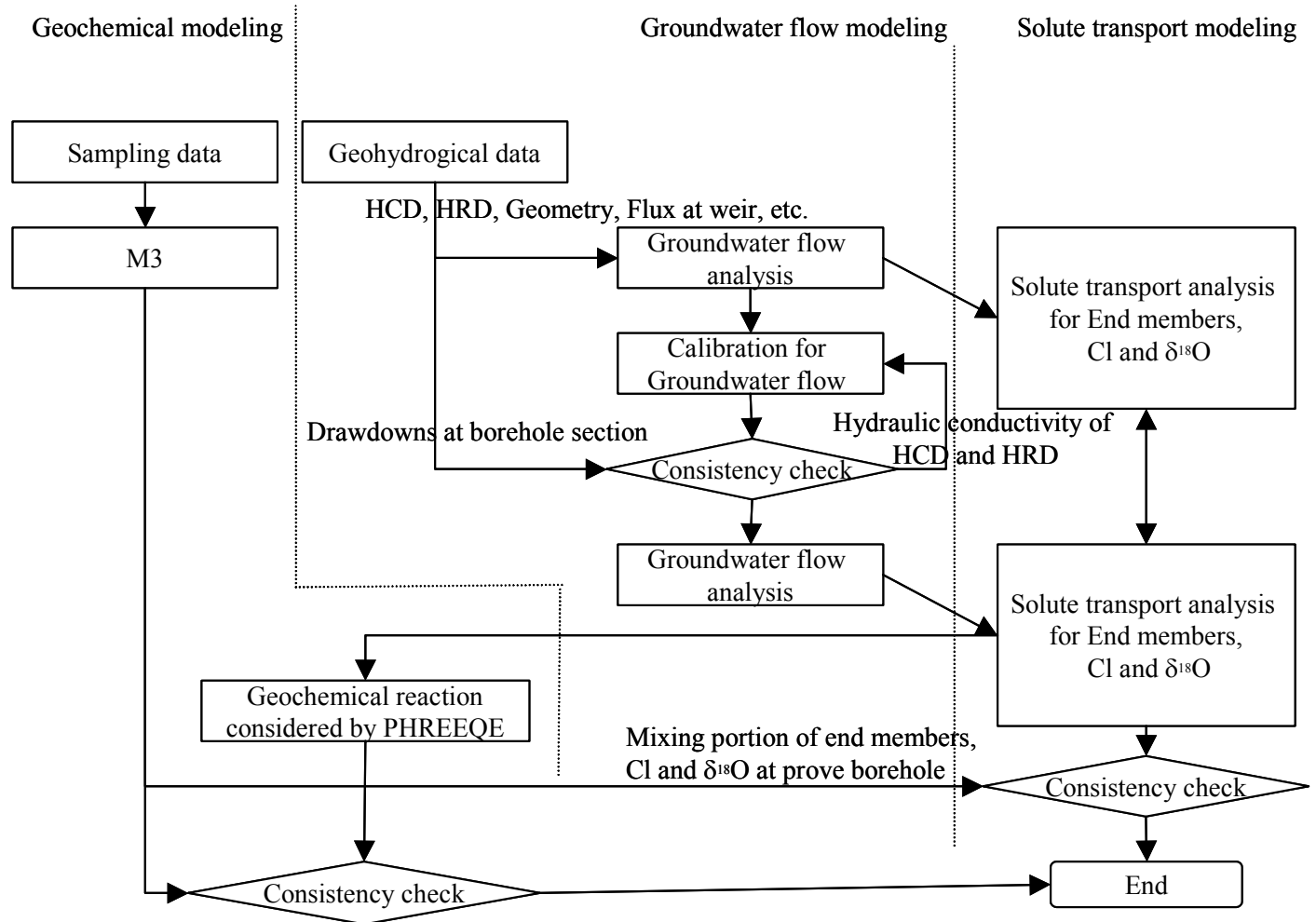
# Modelling steps used (2)

- BMWi/BGR



# Modelling steps used (3)

- CRIEPI



# Task 5: Hydrochemical Modelling

## General

### ***Undisturbed hydrochemical conditions: pre-excavation stage***

- Involves water-rock interaction processes and the mixing of groundwaters from different origins
- The greater the groundwater flow-rate through the bedrock the greater the likelihood that mixing processes dominate
- Since Äspö represents a hydrodynamically active system, at least down to 500-600 m, there is less likelihood of modelling the total system using a near-equilibrium thermodynamic geochemical approach

# Task 5: Hydrochemical Modelling

## General

### ***Disturbed hydrochemical conditions: post-excavation stage***

- Activation of additional mixing processes
- May have also have stimulated chemical reactions
- Some of the chemical reactions may be biologically mediated
- Additional mixing processes and chemical reactions can have a significant impact on modifying the local groundwater chemistry

# Task 5 Modelling: Application and Results

- **Hydrochemical modelling (M3)**

- M3 modelling in Task 5 has a three-fold function:

- to fulfill SKB's contribution to the main Task 5 objective of integrating hydrochemistry with a hydrodynamic groundwater flow model
- to provide the basis to estimate the initial and boundary conditions for the hydrodynamic modelling exercise
- to provide calculated groundwater mixing ratios from each control point to achieve some common ground for model comparison and integration

# Task 5: Hydrochemical Modelling (M3)

- M3 (**M**ultivariate **M**ixing **M**ass balance calculations) was developed to mathematically and objectively classify different groundwater types on the basis of chemistry and degrees of mixing and reactions.
- By identifying the major groundwater sources, i.e. reference water end-members, each groundwater sample can be described by a mixture of all or some of these reference waters by summarising the chemical information in a Principal Component Analysis plot.
- M3, since it considers the effects from mass balance reactions, also has the added advantage of indicating when water/rock interactions are important.

# M3 Modelling: Selected Reference Waters (or end-members)

## ***Selected end-members:***

- Meteoric water - precipitation from the 1960s and infiltration
- Baltic Seawater - modern seawater from Baltic sea
- Brine (saline) water - deep (1700 m) water from Laxemar
- Glacial water - meltwater from last glaciation (10 ka ago)

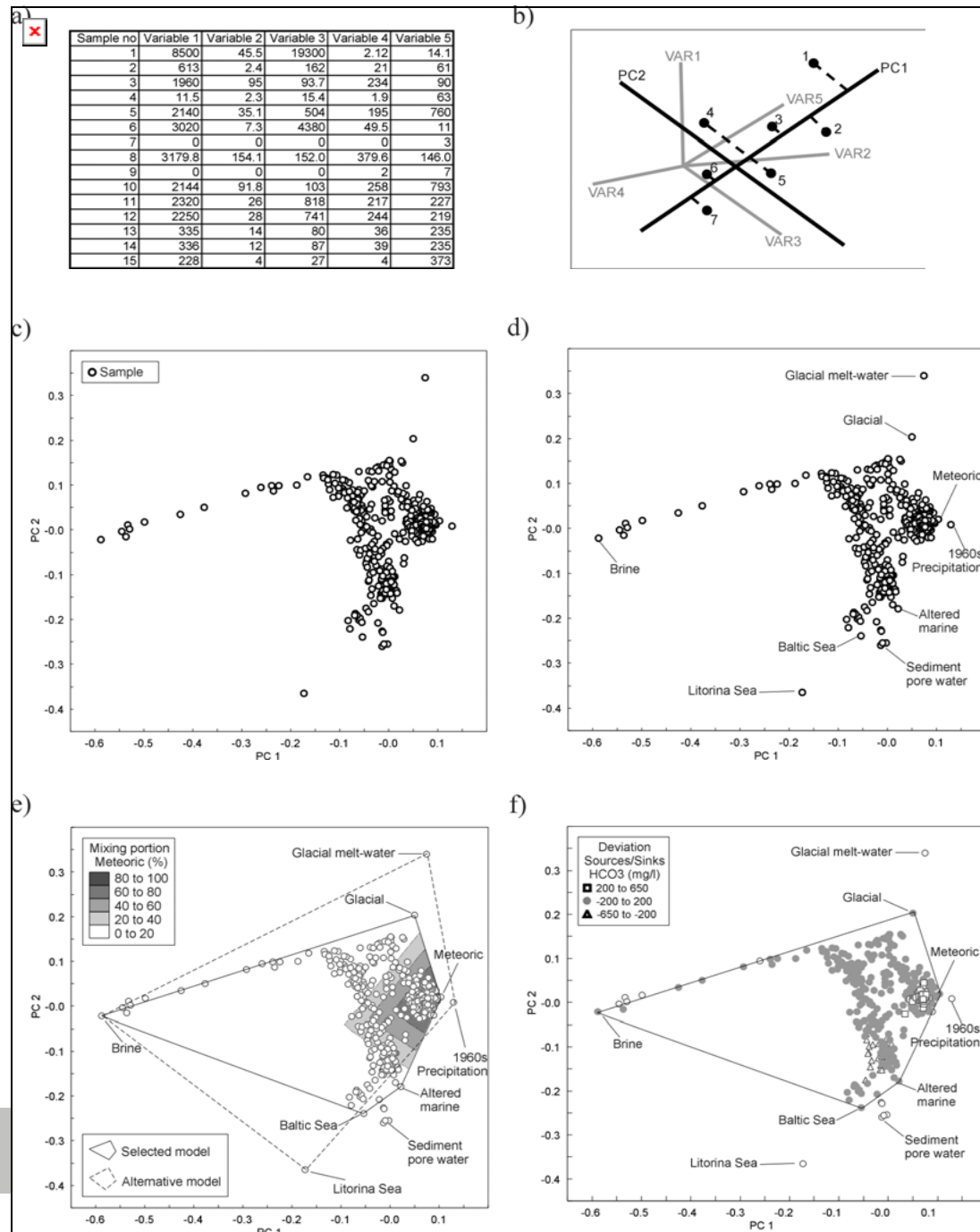
## ***Based on:***

- PCA analysis
- detailed hydrogeochemical study of the Äspö site
- detailed palaeohydrogeological study of the Äspö site
- comparison with other Fennoscandian sites



# M3 modelling

- A schematic visualisation of the different steps in the M3 modelling



# M3 Modelling: Validity of the Model

- This was assessed by comparing the calculated mixing proportions and element contribution for the different reference waters, with the measured values for the difference chemical species in the groundwater samples
- **Agreement:** chemistry largely explained by mixing of selected reference waters
- **Deviation:** Influence of chemical reactions
  - positive deviation indicates a gain (or source) of chemical species
  - negative deviation indicates a loss (or sink) of chemical species

# M3 Modelling: Comparison between average differences in measured vs calculated values for mixing proportion calculations

---

<b>Water Class</b>	<b>Average Difference</b>
<i>Brine</i>	1.2%
<i>Glacial</i>	-0.9%
<i>Meteoric</i>	-0.1%
<i>Baltic Sea</i>	-0.3%

---

# M3 Modelling: Comparison between average differences in measured vs calculated values for mixing proportion

## calculations

Chemical Species	Average Difference
------------------	--------------------

---

<i>Na (mg/L)</i>	-91
<i>K (mg/L)</i>	18
<i>Ca (mg/L)</i>	1356
<i>Mg(mg/L)</i>	-31
<i>CO<sub>3</sub> (mg/L)</i>	-128
<i>Cl (mg/L)</i>	2199
<i>SO<sub>4</sub> (mg/L)</i>	-99
<i>D (‰)</i>	-8
<i><sup>18</sup>O (‰)</i>	-1

---

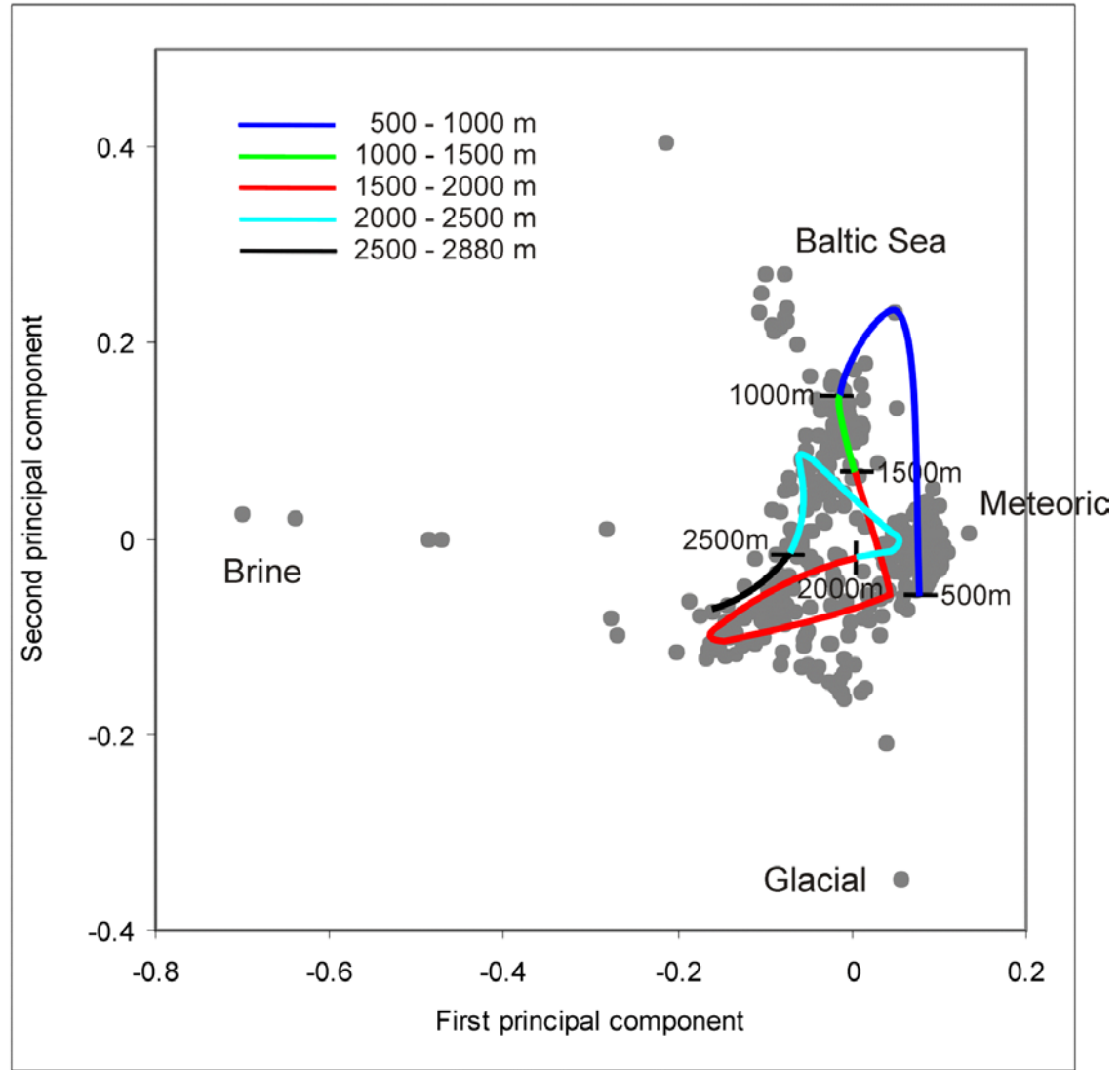
# M3 Modelling: Tunnel Construction

- Modelling and visualising the chemical changes in the groundwater chemistry at the selected Control Points due to tunnel construction (0 to 2900 m tunnel length)

# PCA plot

- PCA plot used to show the general (simplified) changes in groundwater composition in the samples along the tunnel for the **first sample** in the time series.

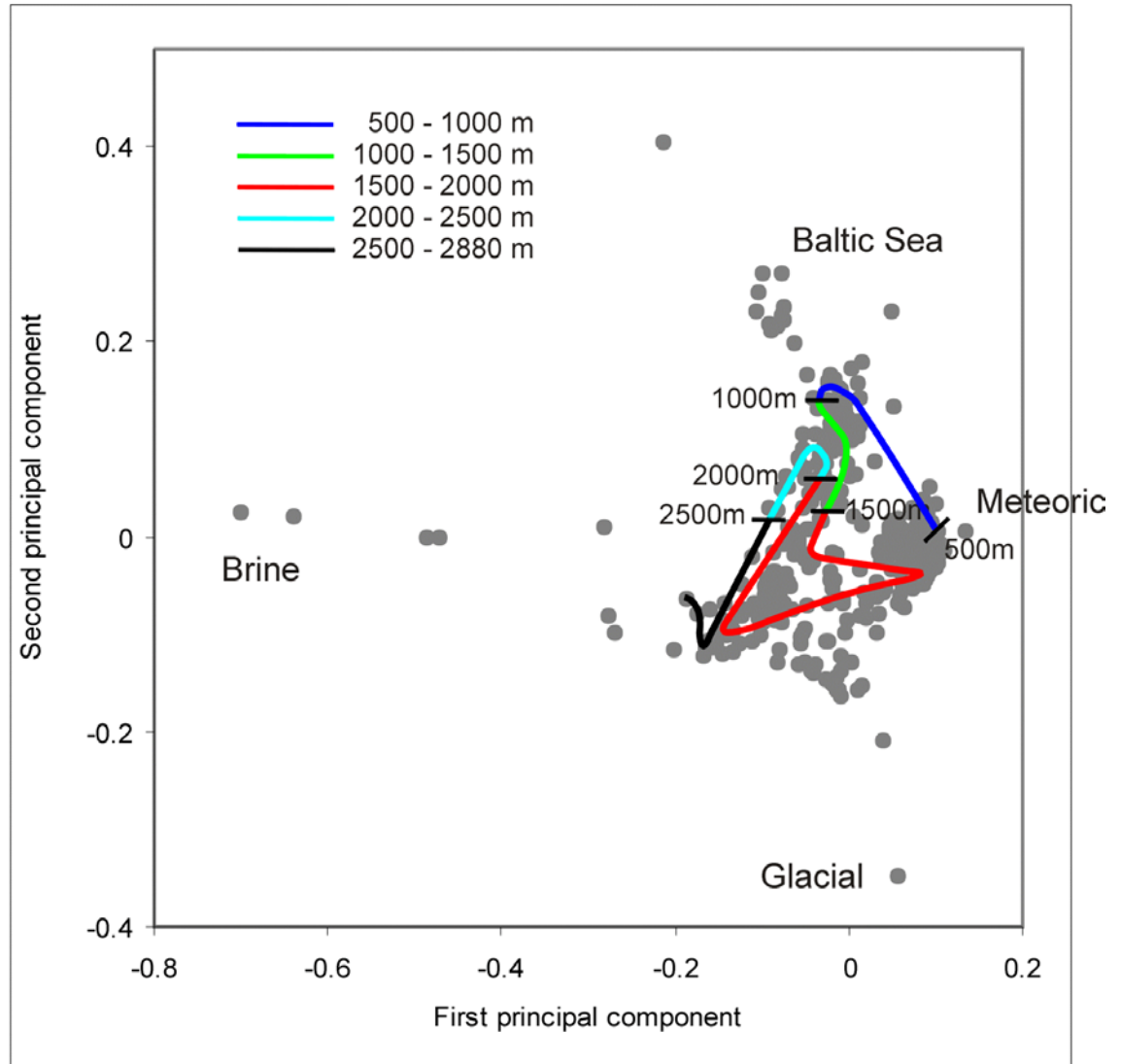
Tunnel position in the PCA, first observation



# PCA plot

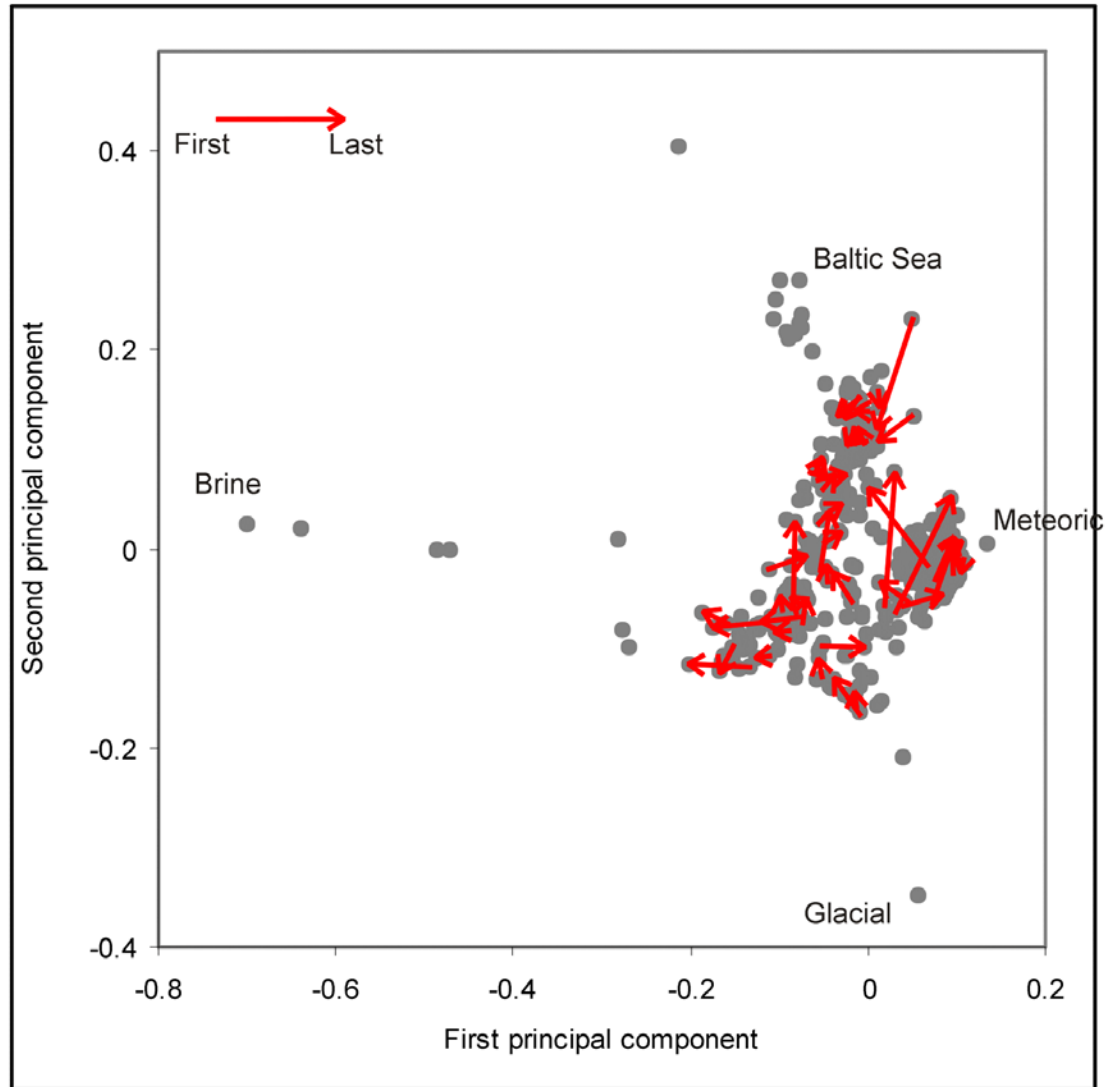
- PCA plot used to show the general (simplified) changes in groundwater composition in the samples along the tunnel for the **last sample** in the time series.

Tunnel position in the PCA, last observation



# PCA plot

- PCA plot used to show the changes in the groundwater composition due to the tunnel construction. **First** refers to the **first sample** taking from the time series, **Last** refers to the **last sample** of that time series.

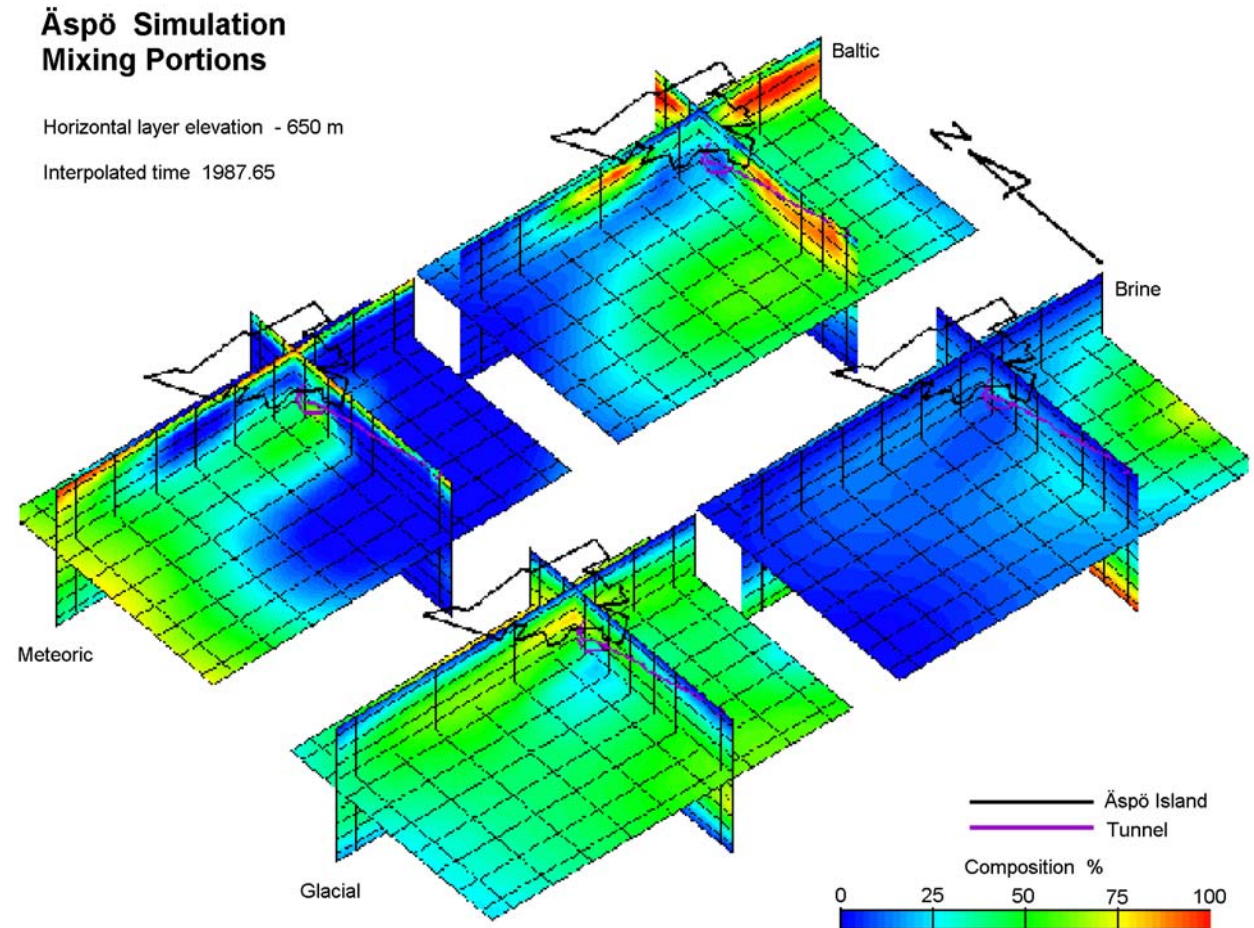




# The result of the interpolation of M3 mixing portion calculations (1)

(3D Voxel Analyst)

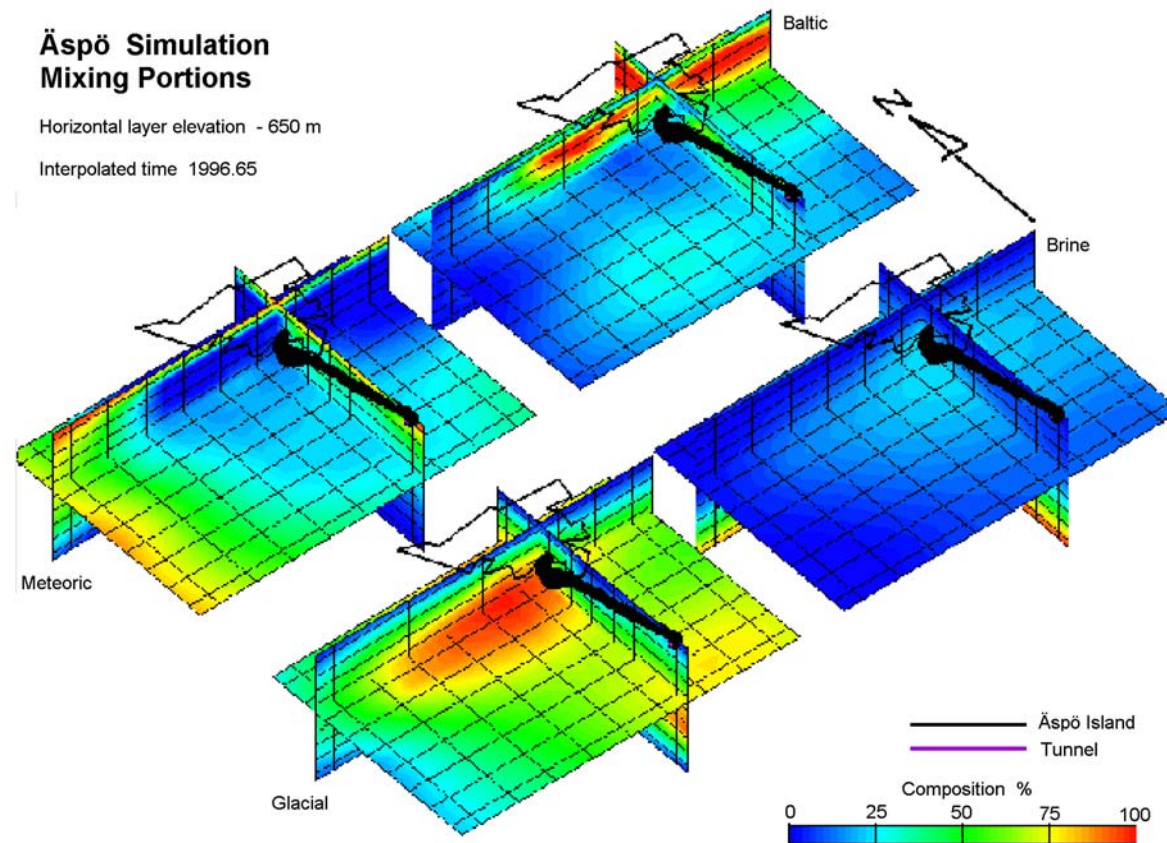
- (Composition %) for Meteoric, Glacial, Baltic and Brine waters **prior** to the Äspö HRL tunnel construction (1987).



# The result of the interpolation of M3 mixing portion calculations (2

(3D Voxel Analyst)

- (Composition %) for Meteoric, Glacial, Baltic and Brine waters **after** the Äspö HRL tunnel construction (1996).



# M3 Modelling

## ***Conclusion on tunnel construction:***

Influence of construction has resulted in:

- drawdown of near-surface Meteoric and Baltic sea signatures towards the tunnel
- inflow of Glacial and Äspö Brine waters from depth

# M3 Modelling: Prediction Exercise

- Comparison of measured and calculated mixing proportions at the selected control points (0 to 2900 m tunnel length)
- Modelled predictions of groundwater mixing ratios at the selected Control Points (2900 to 3600 m tunnel length)

# M3 Modelling

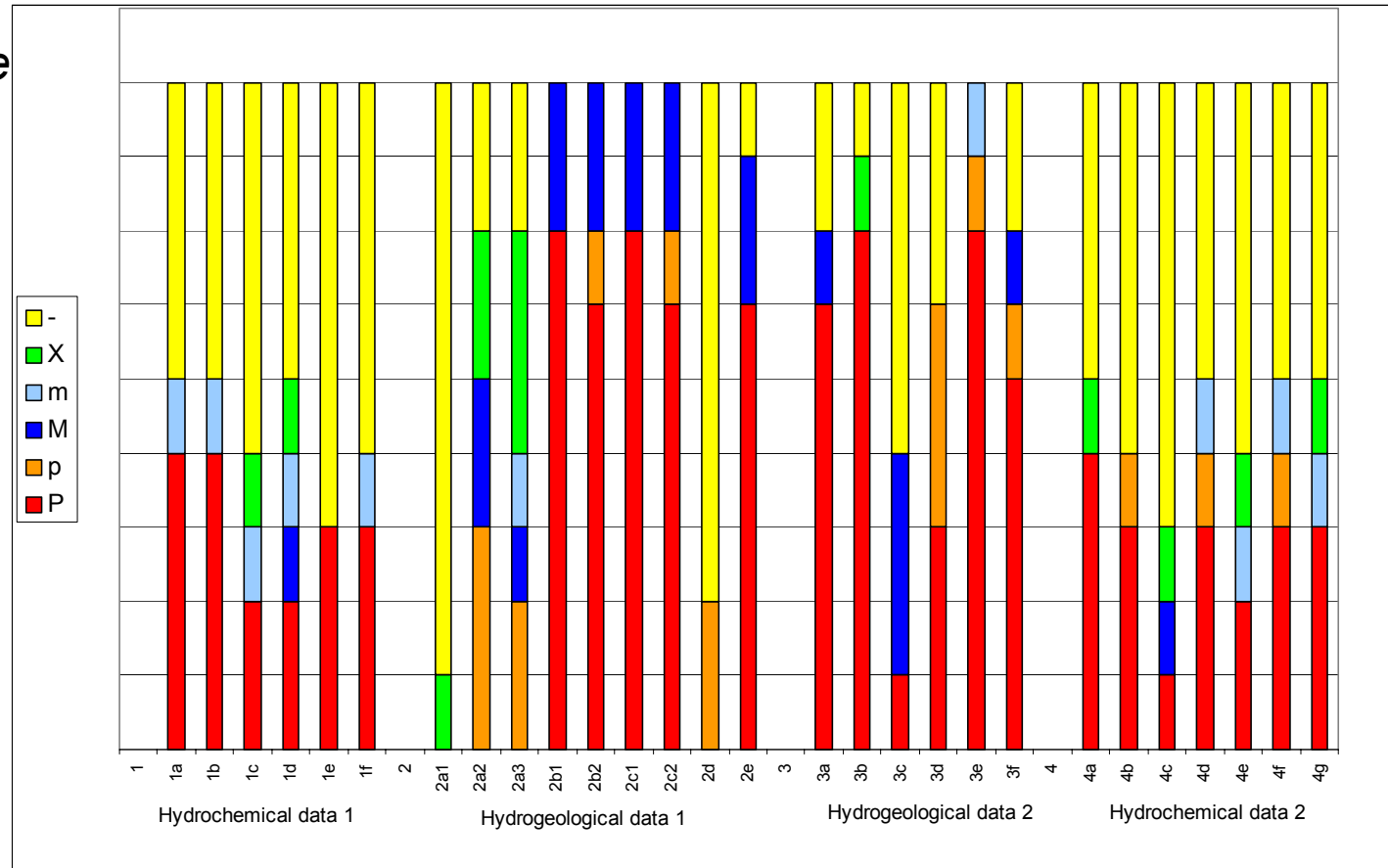
## ***Conclusion on prediction exercise:***

- M3 predictions show a general agreement with the measured values at the Control Points, especially when the uncertainty of the predictions are in the order of +/-0.1 units
- M3 may be used for predictive purposes if there is a time series of observations - this is the case for short-term predictions

# Summary of Data Usage for the Hydrodynamic and Hydrochemical Modelling

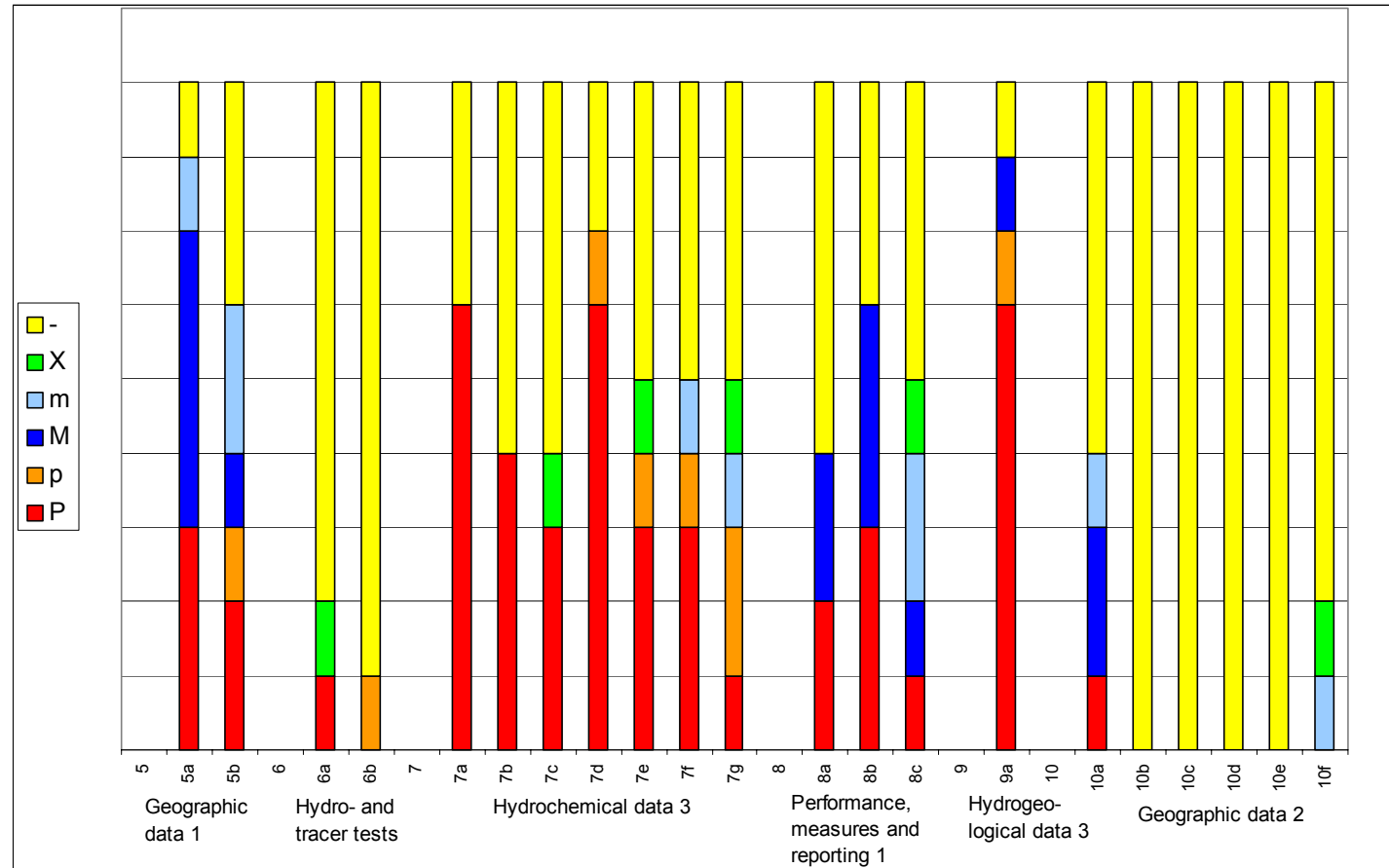
# Data usage (1)

- **P** = data of great importance for quantitative estimation of model parameters,
- **p** = data of less importance for quantitative estimation of model parameters
- **M** = data of great importance used qualitatively for setting up model,
- **m** = data of less importance used qualitatively for setting up model,
- **X** = data useful as general background information,
- **-** = data not used.



# Data usage (2)

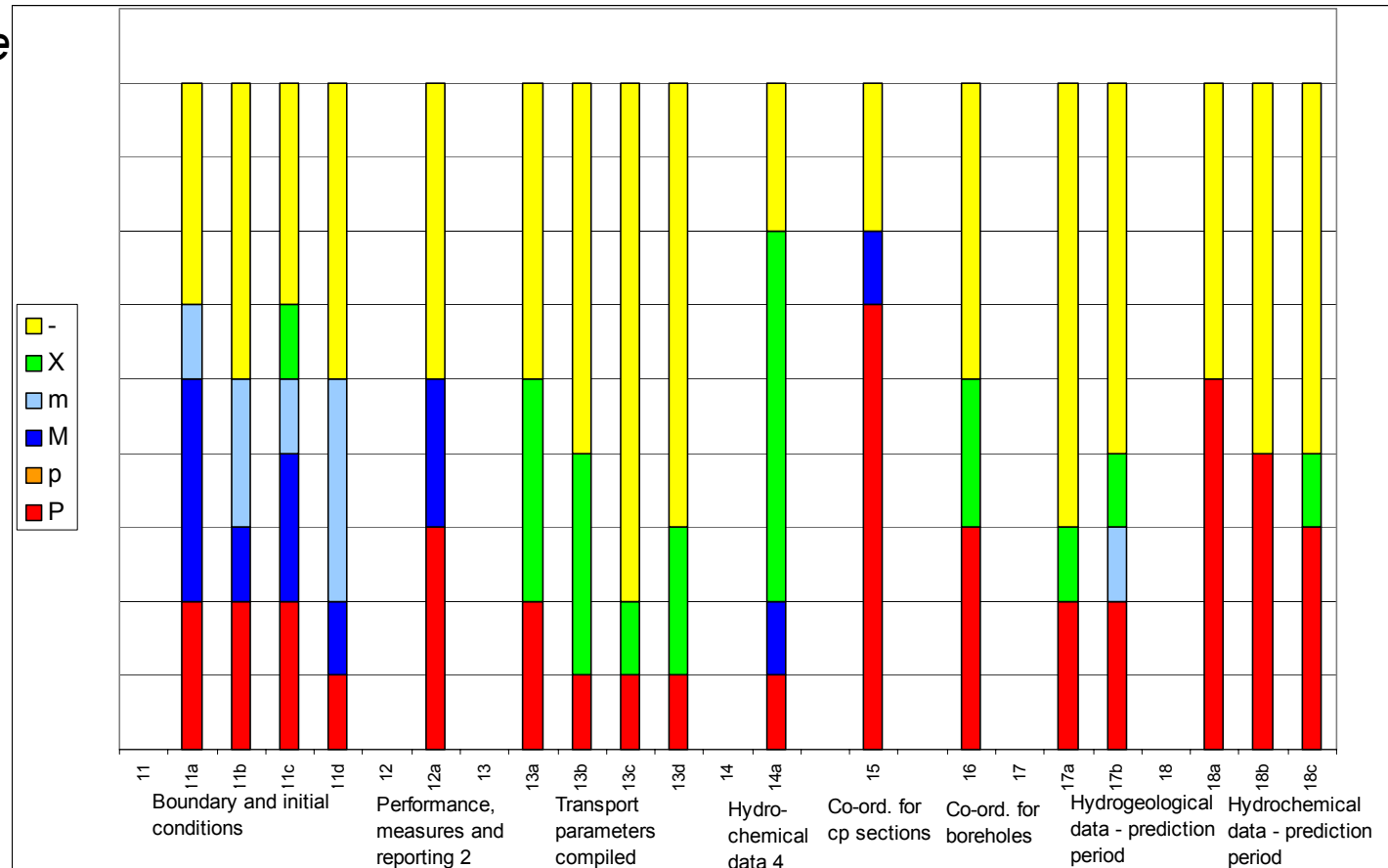
- **P** = data of great importance for quantitative estimation of model parameters,
- **p** = data of less importance for quantitative estimation of model parameters
- **M** = data of great importance used qualitatively for setting up model,
- **m** = data of less importance used qualitatively for setting up model,
- **X** = data useful as general background information,
- **-** = data not used.





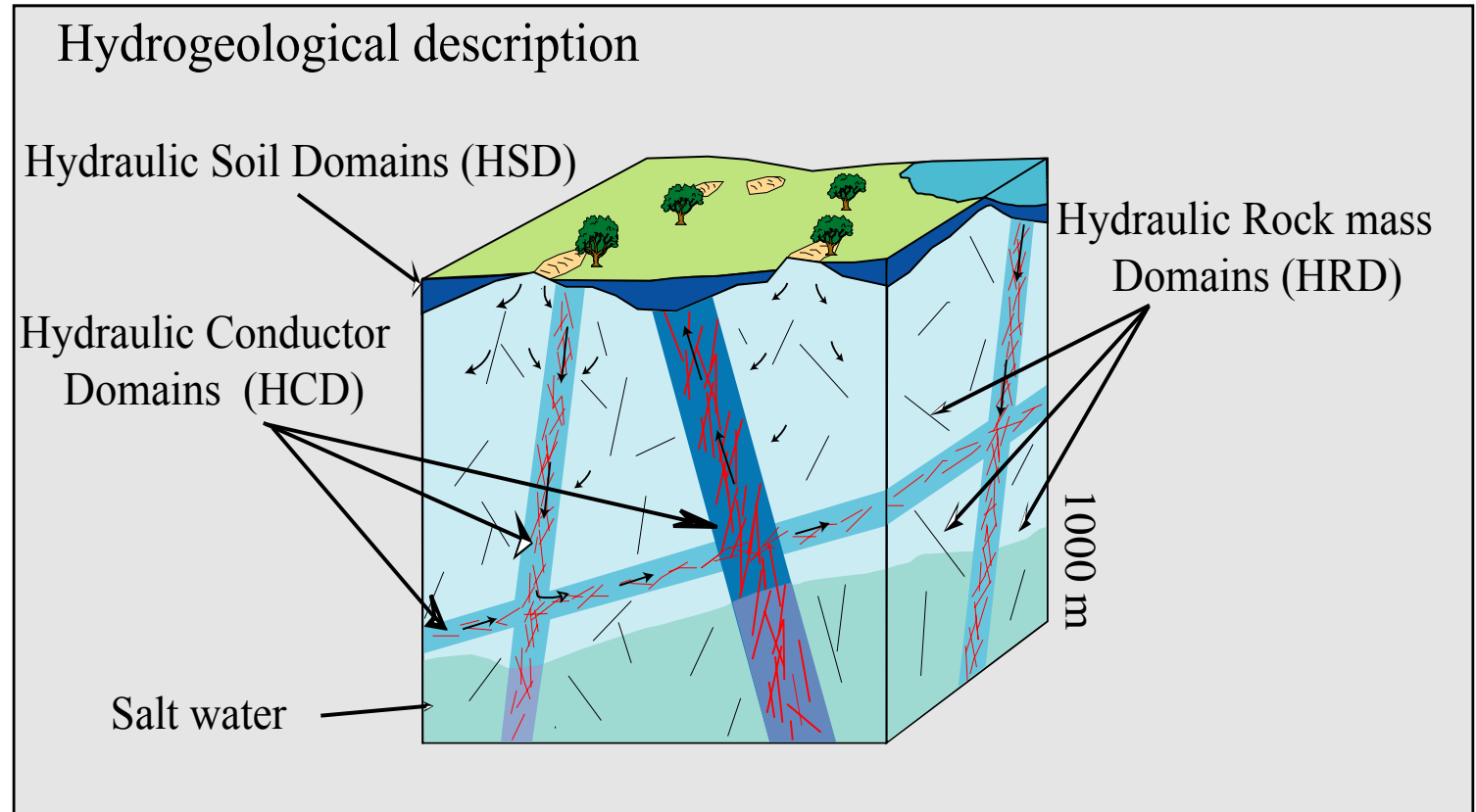
# Data usage (3)

- **P** = data of great importance for quantitative estimation of model parameters,
- **p** = data of less importance for quantitative estimation of model parameters
- **M** = data of great importance used qualitatively for setting up model,
- **m** = data of less importance used qualitatively for setting up model,
- **X** = data useful as general background information,
- **-** = data not used.

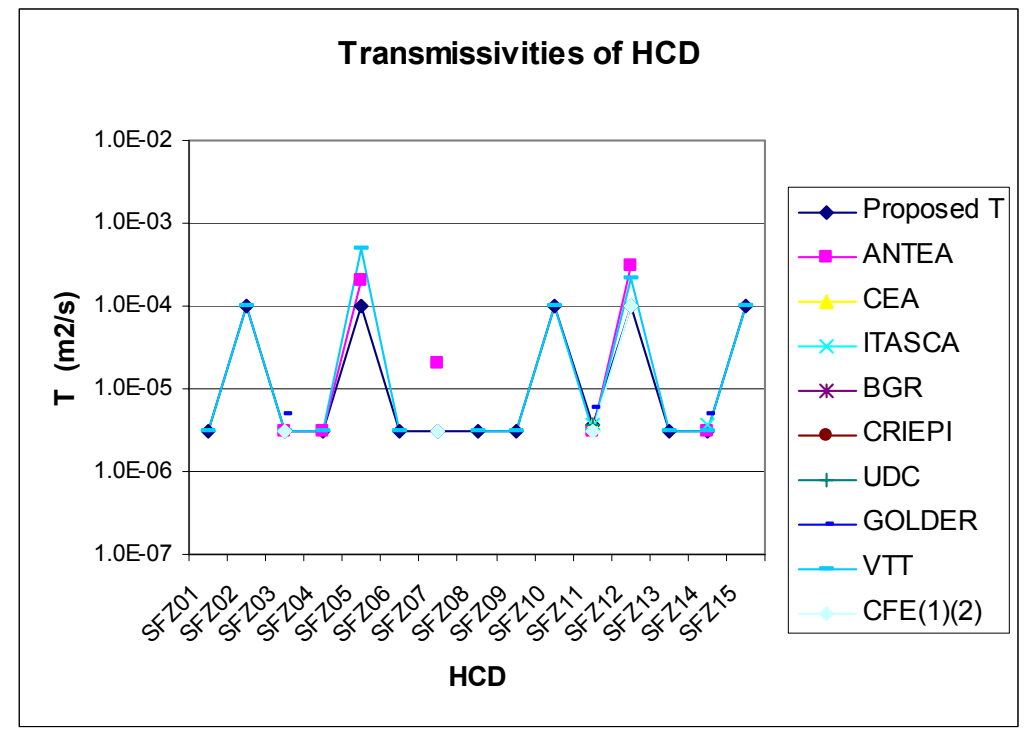
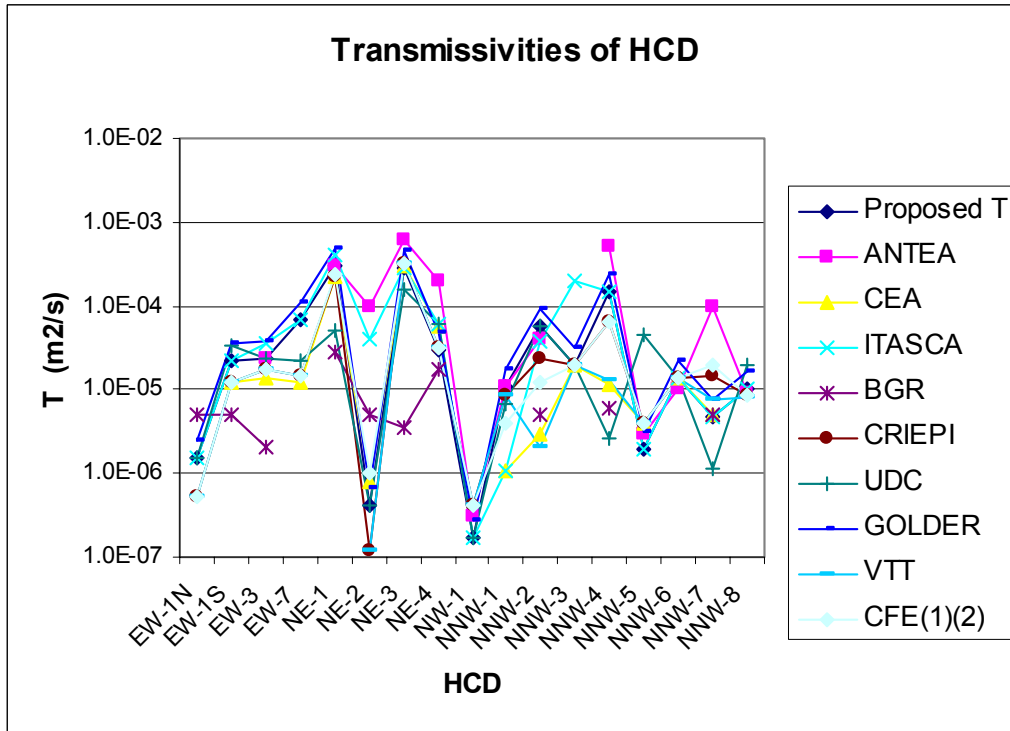


# Task 5: Hydrodynamic Modelling

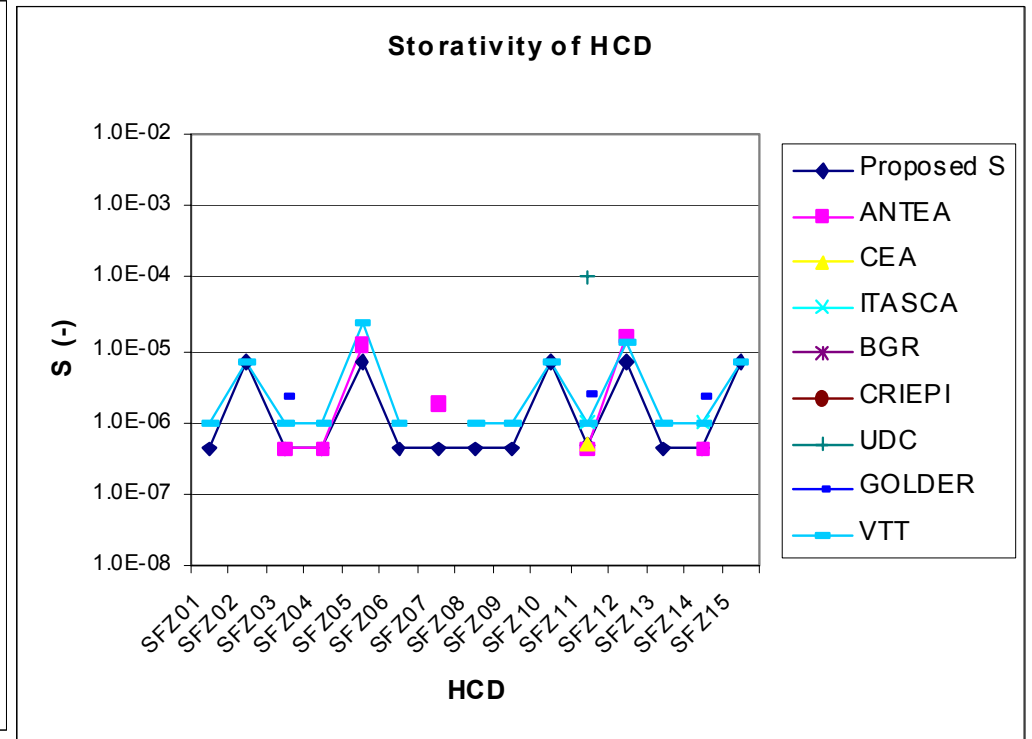
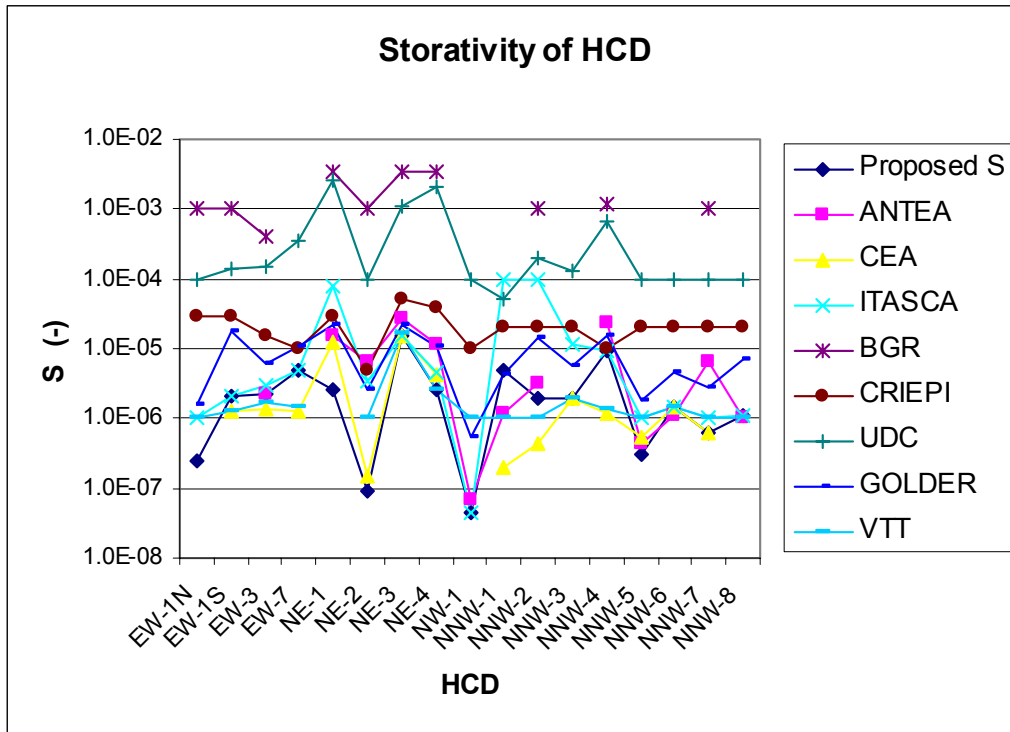
- Main geometrical units



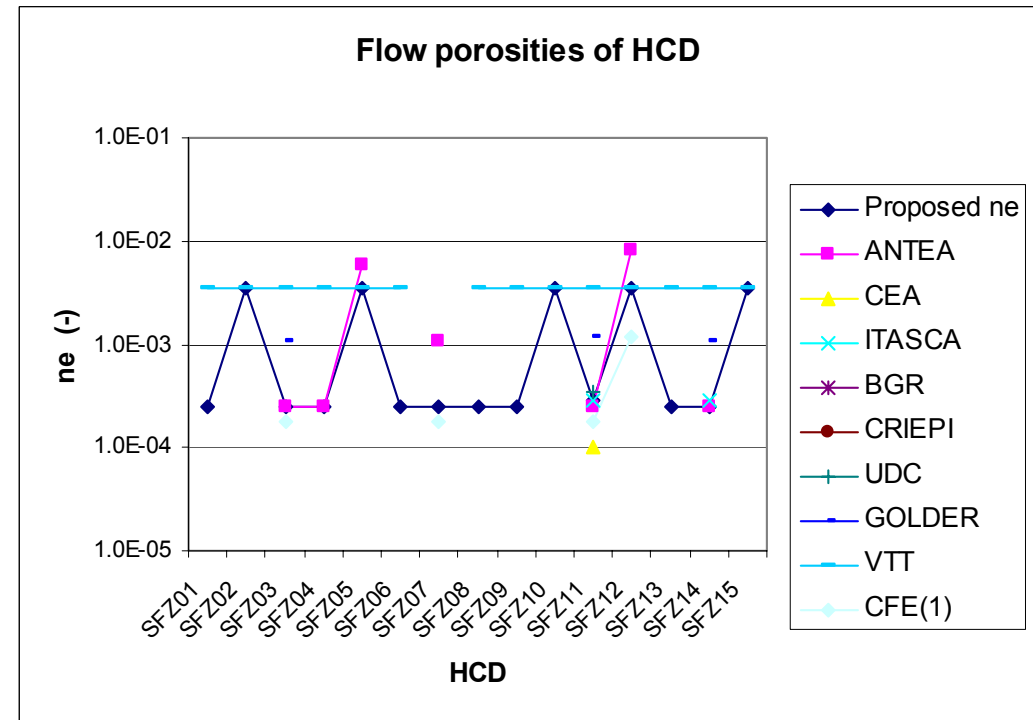
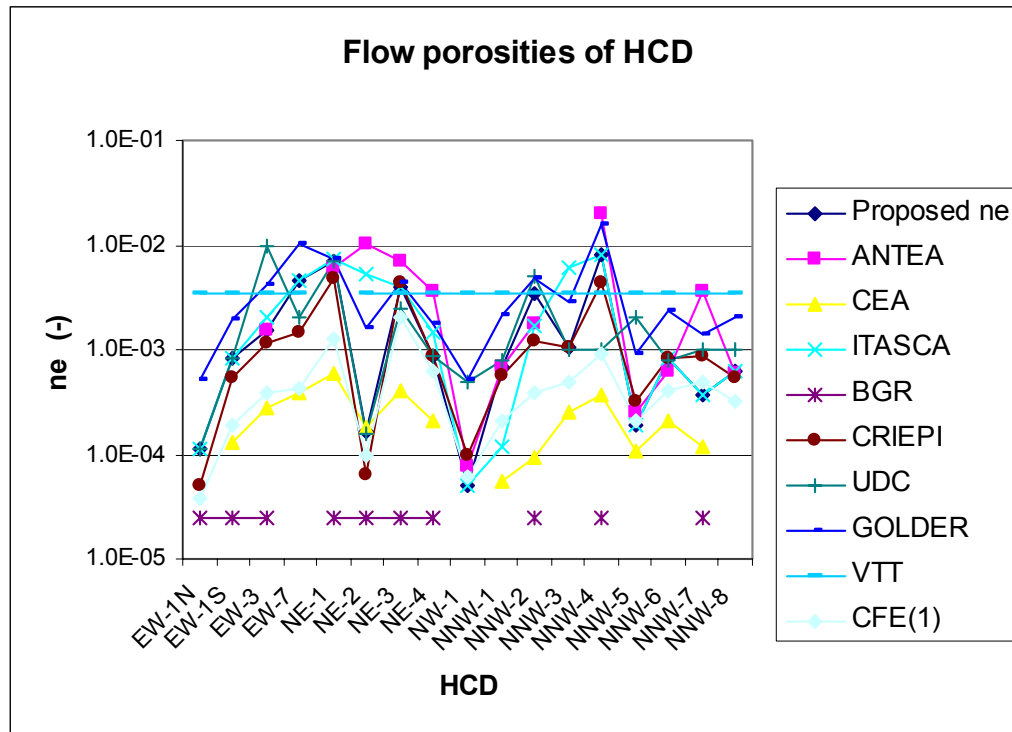
# Final calibration, HCD, transmissivities



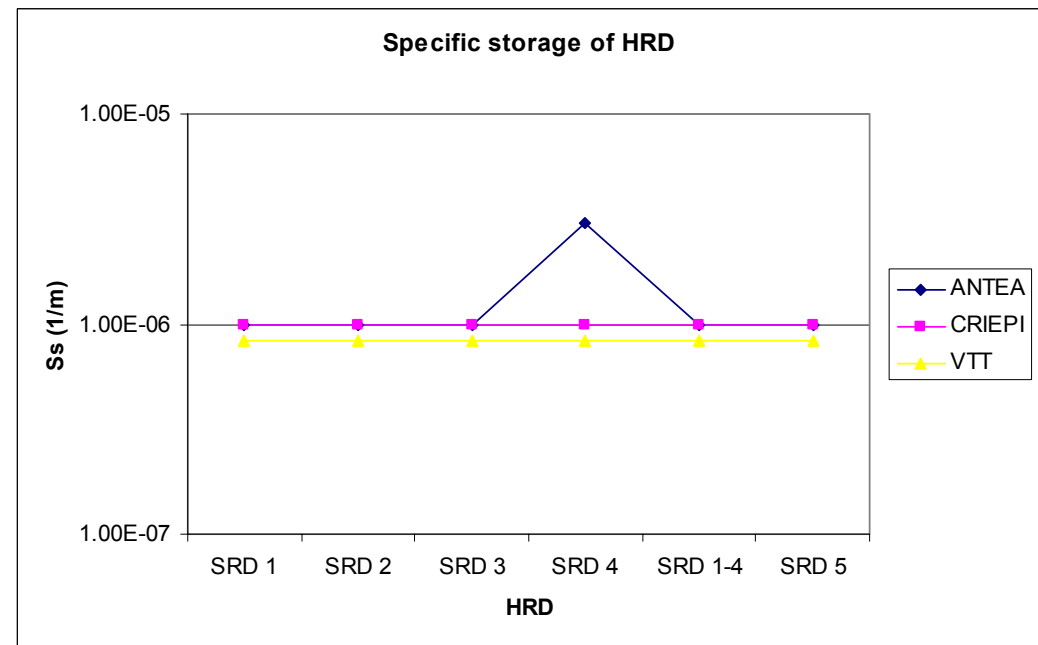
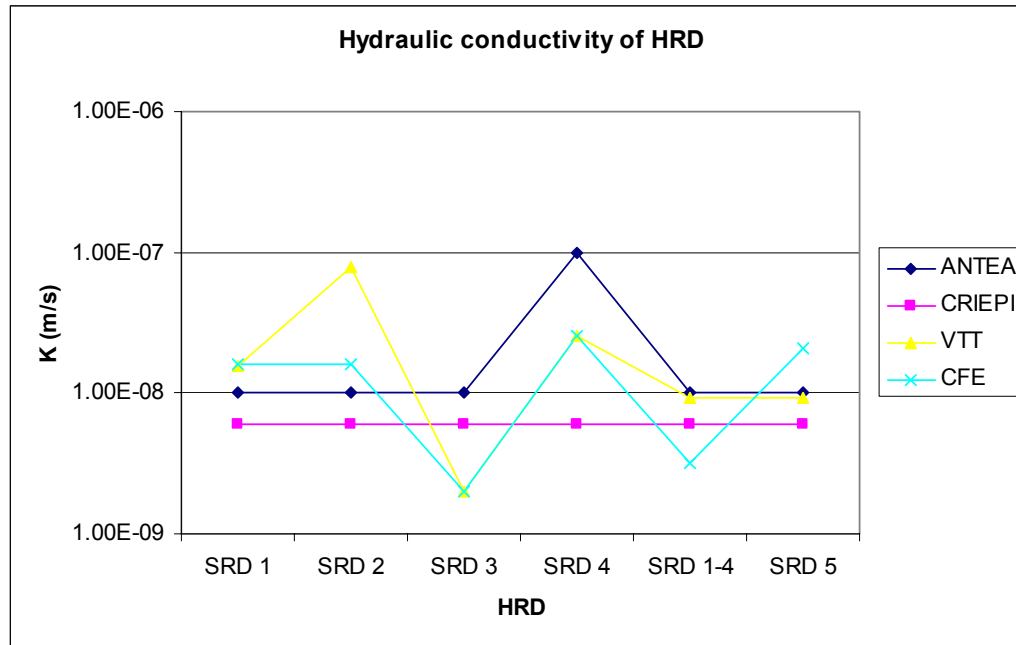
# Final calibration, HCD, storativity



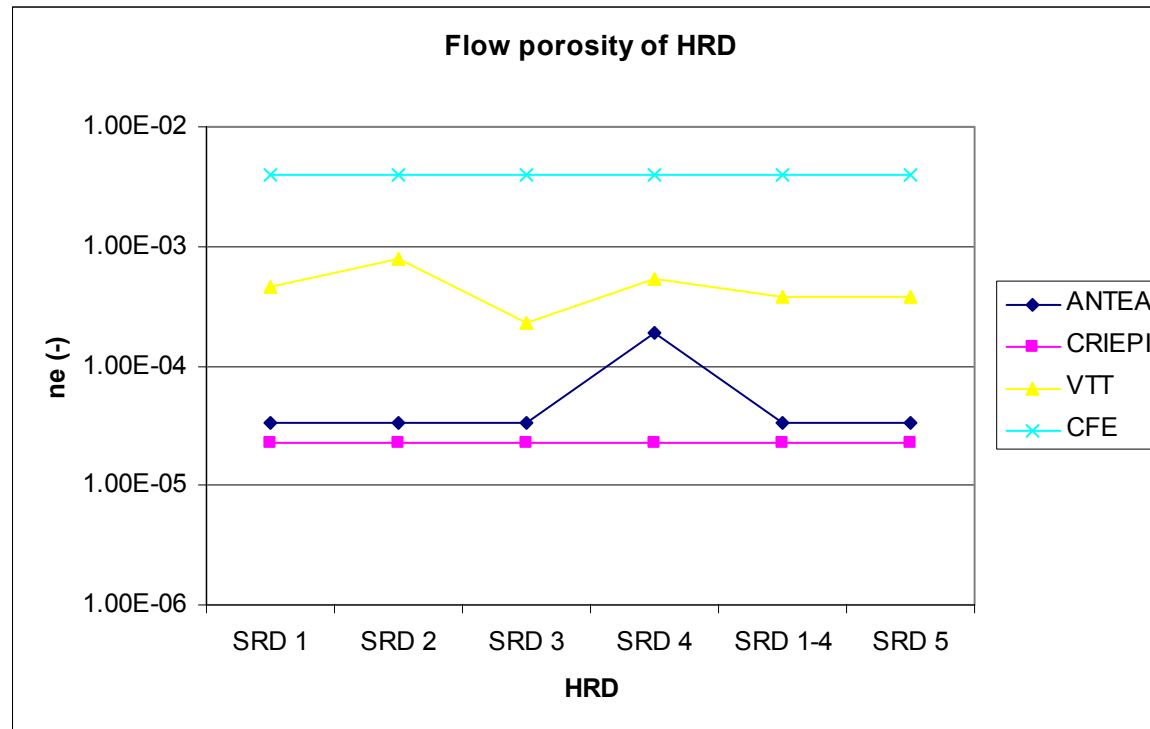
# Final calibration, HCD, kinematic porosity



# Final calibration, HRD, Hydraulic conductivity and specific storage

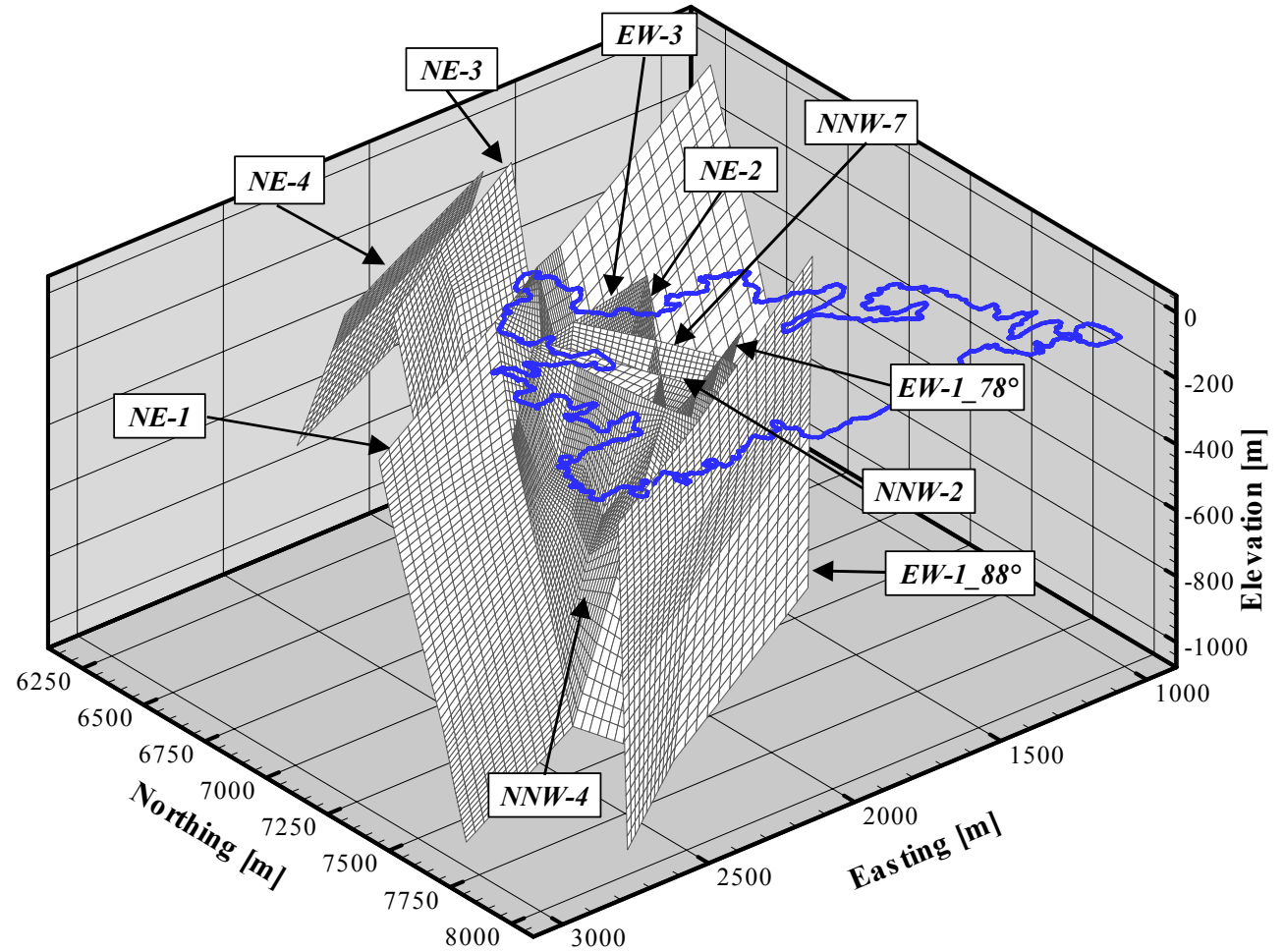


# Final calibration, HRD, kinematic porosity



# Modelling approaches used

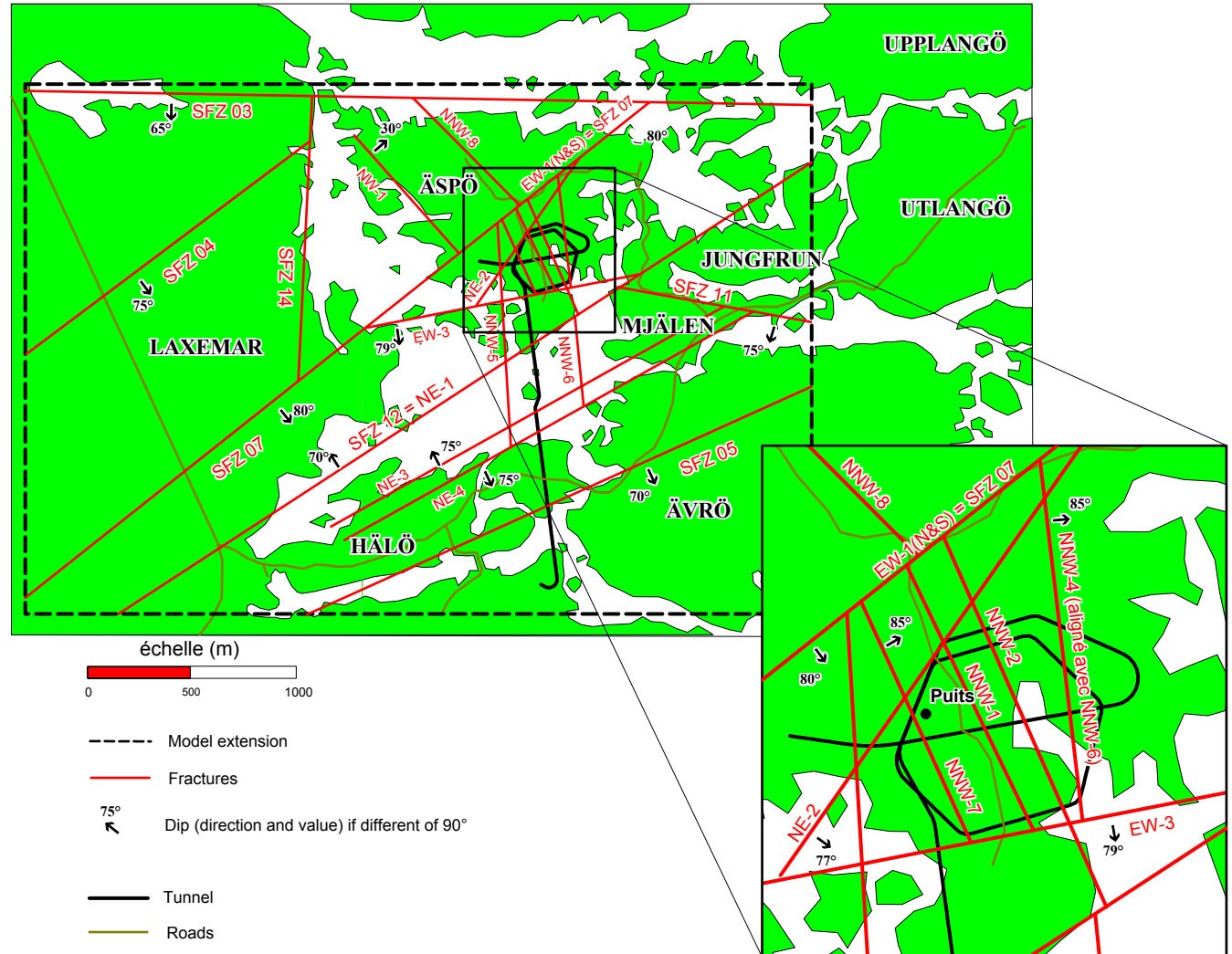
- Modelling HCD
- Example: BMWi/BGR



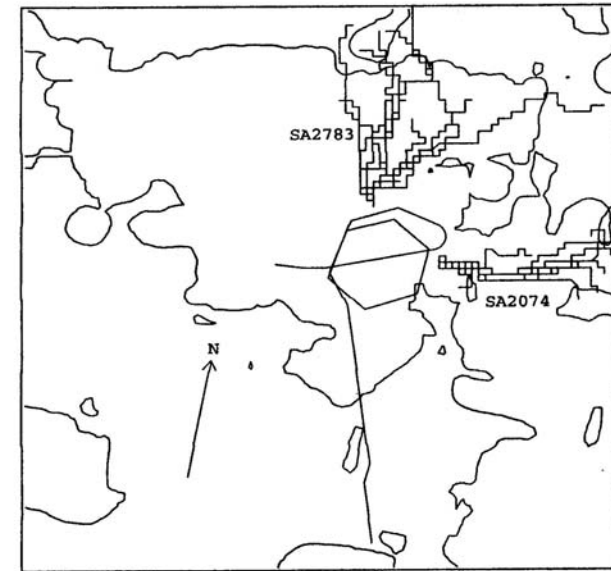
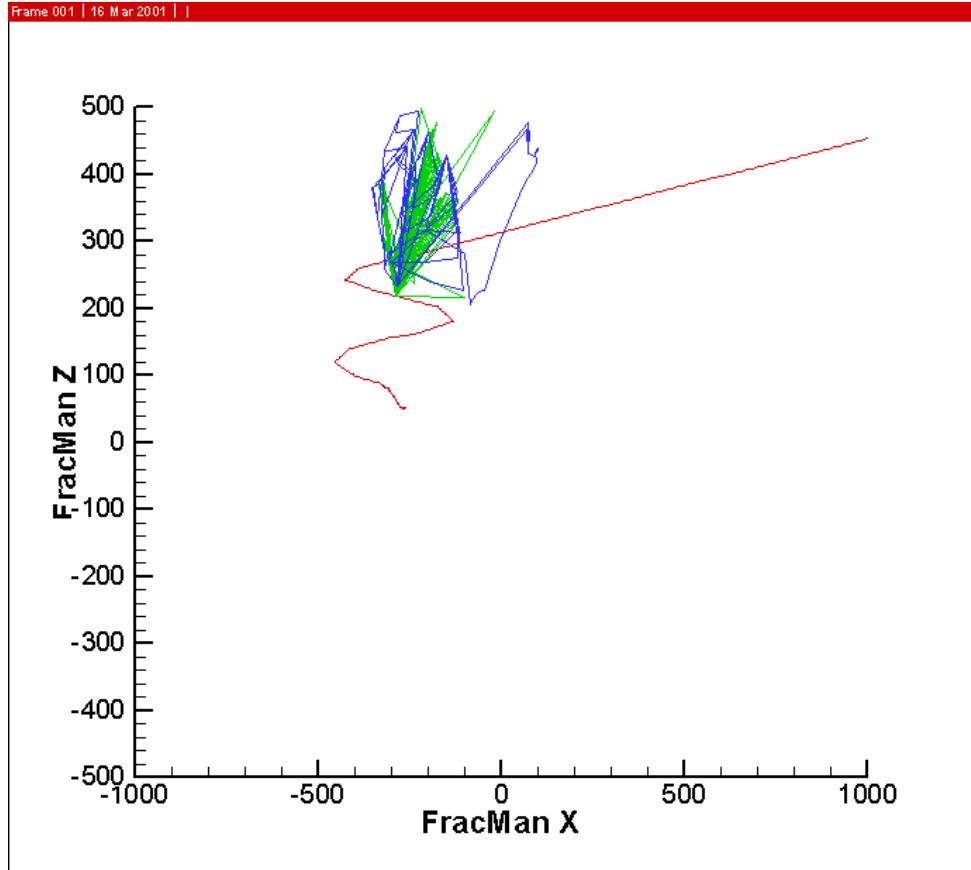


# Modelling approaches used

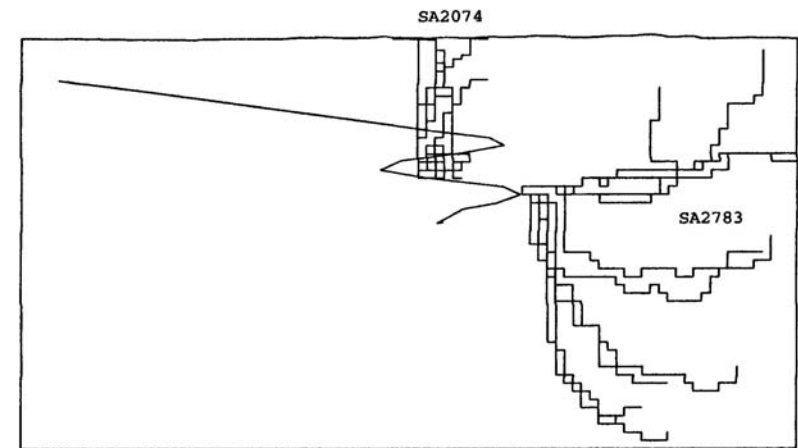
- Modelling HCD+ HRD
- Example: ANDRA/ANTEA



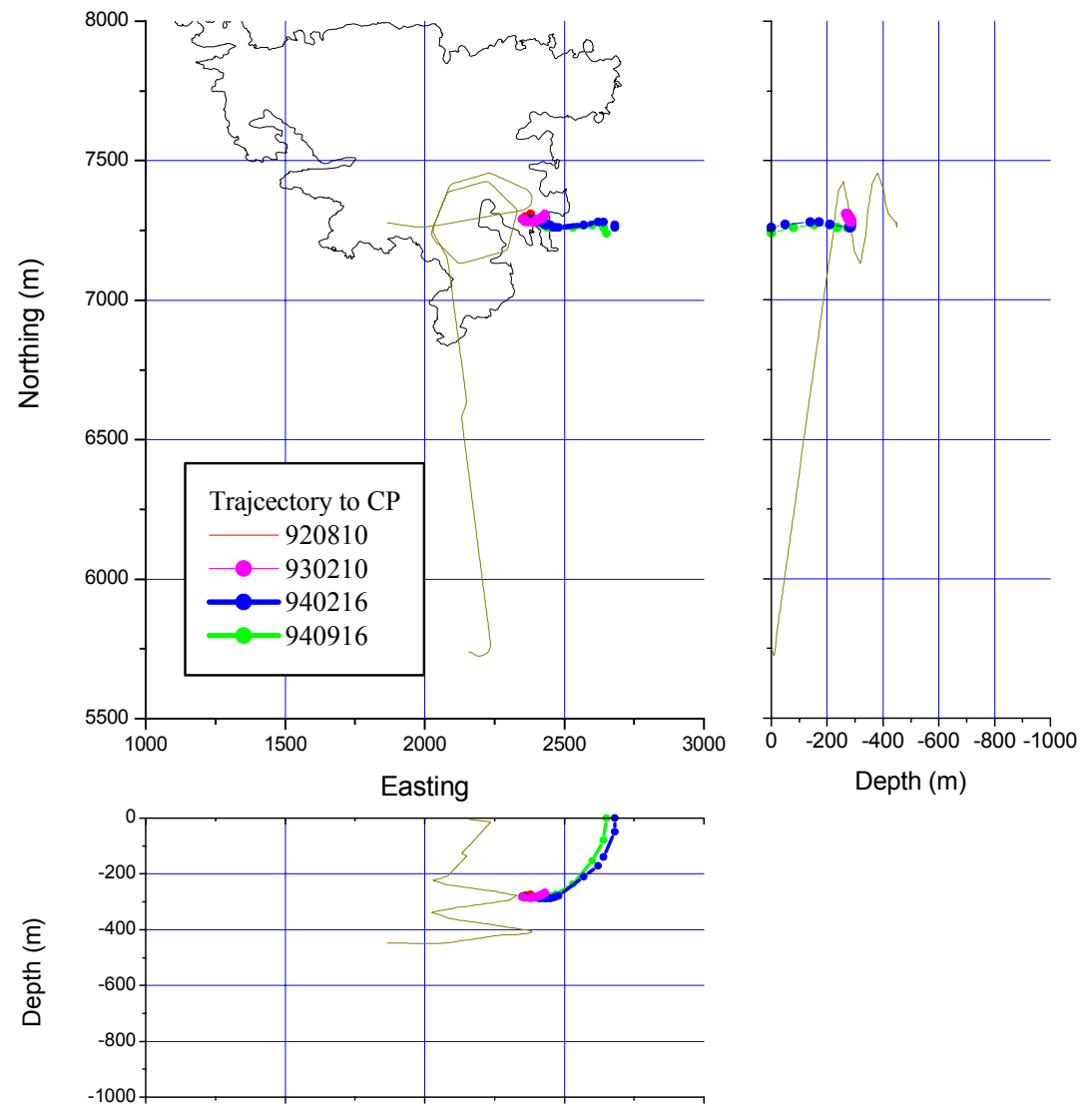
# Flow paths: SKB/CFE and JNC/Golders



Scale: |-----| 200 m



# Flow paths: CRIEPI

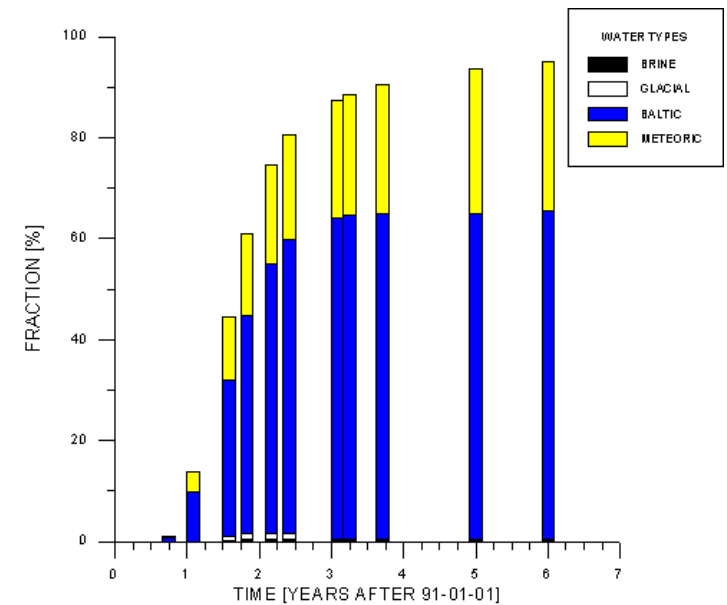
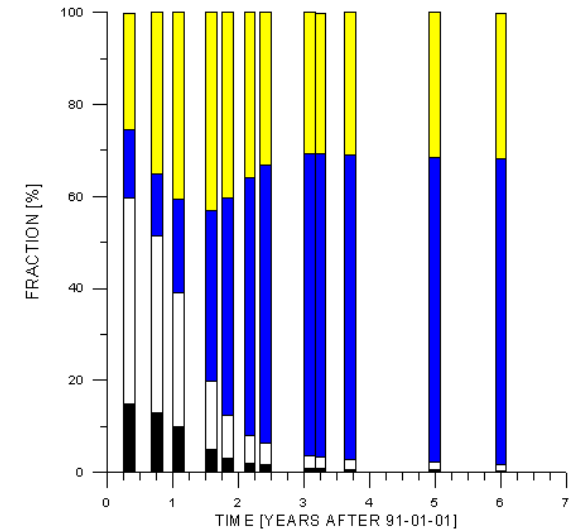
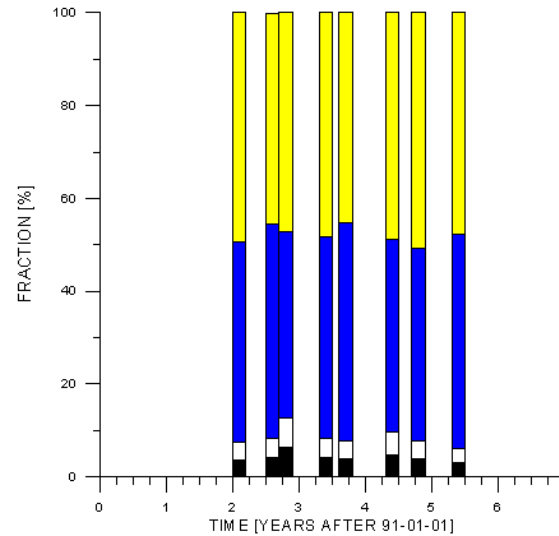


# Task 5: Hydrodynamic Simulation of M3 Mixing Ratios

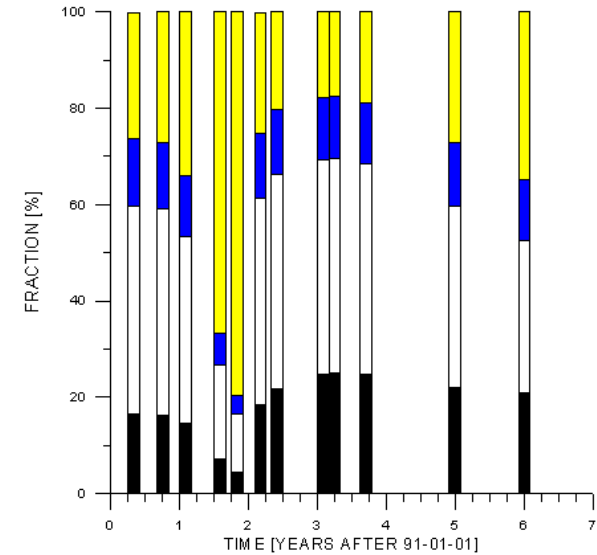
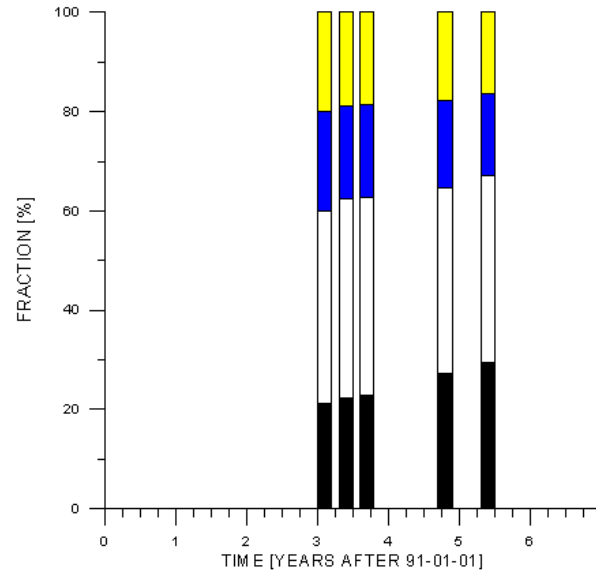
# SKB/CFE: Mixing Proportions (cp)

(~100 m below the Baltic Sea)

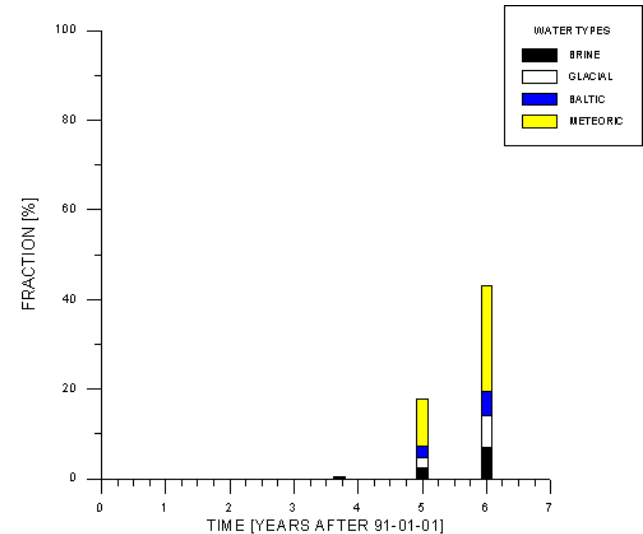
- *Water composition in control point SA0813 as a function of time. Measured (top left) and simulated (top right) composition and fraction coming from the domain boundaries (right). Time for tunnel passing the point: 0.58*



# SKB/CFE: Mixing Proportions (cp) (~400 m below Äspö)



- *Water composition in control point SA2783 as a function of time. Measured (top left) and simulated (top right) composition) and fraction coming from the domain boundaries (right). Time for tunnel passing the point: 3.03.*



# Task 5: Influence of Chemical Reactions on Groundwater Mixing Proportions

# Task 5: Influence of chemical reactions at Äspö

## ***Undisturbed hydrochemical conditions: pre-excavation stage***

- Involves water-rock interaction processes although mixing processes dominate

## ***Disturbed hydrochemical conditions: post-excavation stage***

- Activation of additional mixing processes
- This may have stimulated chemical reactions
- Some of the chemical reactions may be biologically mediated
- Additional mixing processes and chemical reactions can have a significant impact on modifying the local groundwater chemistry



# Task 5: Influence of chemical reactions at Äspö

***Task 5 Project identified the following reactions as being potentially important:***

- Organic decomposition in the uppermost part of the bedrock - can result in a gain of  $\text{HCO}_3$  in the system
- Organic redox reactions in the shallow part of the bedrock - can result in a gain of Fe and  $\text{HCO}_3$  in the system
- Inorganic redox reactions in the shallow part of the bedrock - can result in a gain of  $\text{SO}_4$  in the system
- Dissolution and precipitation of calcite - can result in a loss or a gain of Ca and  $\text{CO}_3$

# Task 5: Influence of chemical reactions at Äspö

- Ion-exchange particularly in the presence of fracture clay material - can result in a change in Na/Ca ratio
- Sulphate reduction by microbiological activity in the upper bedrock - can result in a loss of  $\text{SO}_4$  and a gain of  $\text{HCO}_3$

# Task 5: Hydrochemical Modelling (SKB)

## ***Modelling approach:***

- Mass balance reactions are used to define sources and sinks for different elements which deviate from the ideal mixing model used in the mixing calculations. Deviation indicates potential chemical reactions.
- Thus, by using the M3 modelling approach the degree of groundwater mixing can be estimated and the contribution of chemical reactions indicated.

# Task 5: Hydrochemical Modelling (SKB)

## ***Results:***

- M3 predictions show a general agreement with the measured values at the Control Points
- Significant deviations from ideal mixing are shown by  $\text{Na}^+$ ,  $\text{Ca}^{2+}$ ,  $\text{HCO}_3^-$  and  $\text{SO}_4^{2-}$ , which is consistent with other hydrochemical studies made at Äspö
- This information is useful in qualitatively identifying the nature of the chemical reactions

# Task 5: Hydrochemical Modelling (BMW/BGR)

## ***Modelling approach:***

- Deviations from an ideal mixing model can be identified by applying a chemical model.
- The hydrogeochemical model used is based on PHREEQC (Version 2) which can handle speciation, batch reaction and inverse geochemical calculations.
- The model indicates:
  - which processes dominate and to what extent
  - which constituents and pure phases participate in the reactions

# Task 5: Hydrochemical Modelling (BMW/BGR)

## *Input data:*

- Measured time series groundwater chemistry was used to simulate compositions at the Control Points
- Most important ions used:  $\text{Na}^+$ ,  $\text{Cl}^-$ ,  $\delta^2\text{H}$  and  $\delta^{18}\text{O}$  (conservative) and  $\text{K}^+$ ,  $\text{Ca}^{2+}$ ,  $\text{Mg}^{2+}$ ,  $\text{HCO}_3^-$  and  $\text{SO}_4^{2-}$  (non-conservative/reactive)
- Most important reactions considered:
  - Dissolution/precipitation of carbonate (gain of  $\text{HCO}_3^-$ )
  - Dissolution of gypsum (loss of  $\text{Ca}^{2+}$ )
  - Dissolution of dolomite (gain of  $\text{SO}_4^{2-}$ )
  - Cation exchange (loss of  $\text{K}^+$ ; gain of  $\text{Na}^+$  and  $\text{Mg}^{2+}$ )
  - Organic decomposition (gain of  $\text{HCO}_3^-$ )
  - Oxidation of pyrite/organic matter (gain of  $\text{SO}_4^{2-}$ )
  - Degassing of  $\text{CO}_2$  (loss of  $\text{Ca}^{2+}$ ; loss of  $\text{HCO}_3^-$ )

# Task 5: Hydrochemical Modelling (BMW/BGR)

## ***Calculations and results:***

- For each water sample the proportions of the different groundwater end-members were calculated using chloride, sodium and  $^{18}\text{O}$  as conservative tracers
- Using these proportions the non-conservative elements were determined
- These non-conservative elements showed a deviation from the measured values
- This deviation was minimised by equilibrium calculations
- Cation-exchange reactions were also considered
- Due to the revised mixture ratios the concentrations of the non-conservative species, i.e.  $\text{Ca}^{2+}$ ,  $\text{Mg}^{2+}$ ,  $\text{HCO}_3^-$ ,  $\text{SO}_4^{2-}$  (exception  $\text{K}^+$ ), are in better accordance with the measured values.

# Task 5: Hydrochemical Modelling (CRIEPI)

## ***Modelling approach:***

- Initial compositions of the four recommended end-members were first defined, based on the measured chemistry
- The chemical species of the mixed water (i.e. at the Control Points) were then calculated from the mixing proportions as predicted from the M3 results
- This was repeated using the mixing proportions as predicted from the FEGM/FERM results
- Finally, these mixed water compositions were modelled using the geochemical equilibrium HARPHRQ code to identify which major geochemical reactions have contributed to the calculated chemistry



# Task 5: Hydrochemical Modelling (CRIEPI)

## ***Most important reactions considered:***

- $\text{HCO}_3^-$  production - decomposition of organic material
- Consumption of dissolved oxygen - near-surface pyrite oxidation
- Dissolution and precipitation of calcite
- Cation-exchange between Ca and Na by clay minerals
- Oxidation/reduction between  $\text{HS}^-$  and  $\text{SO}_4^{2-}$

# Task 5: Hydrochemical Modelling (CRIEPI)

## ***Results:***

- decomposition of organic material appears to control the concentration of  $\text{HCO}_3^-$  in the majority of cases
- cation-exchange reactions are significant
- taking both reactions into consideration resulted in a closer agreement with the measured values

# Task 5: Coupling of Transport and Geochemistry (ANDRA/Itasca)

## ***Coupling with geochemistry:***

- Fully coupled reactive transport modelling was restricted to part of the model domain
- Modelling approach assumes thermodynamic equilibrium - reaction kinetics are considered either very fast or very slow with respect to the groundwater residence times
- Chemical species were preferred to the M3 mixing ratios. The principal components (i.e. initial conditions) selected were:  $\text{Na}^+$ ,  $\text{K}^+$ ,  $\text{Ca}^{2+}$ ,  $\text{Mg}^{2+}$ ,  $\text{CO}_3^{2-}$ ,  $\text{Cl}^-$  and  $\text{SO}_4^{2-}$ .

# Task 5: Coupling of Transport and Geochemistry (ANDRA/Itasca)

- Major reaction of concern selected was calcite dissolution/precipitation
- This was extended to include magnesium carbonates and gypsum
- Using the CHEMVAL database all relevant soluble chemical complexes were included

# Task 5: Coupling of Transport and Geochemistry (ANDRA/Itasca)

## ***Procedure and results:***

- Coupled modelling was used to simulate the impact of the tunnel construction over a period of 100 days
- Simulations indicated that variable water salinity influences the aqueous solution ionic strength and consequently the ‘apparently, chemical reaction constants
- Reactive transport results show that even were geochemistry is considered as simple and of little importance, transport of chemical species might in fact be affected by mineral precipitation/dissolution, therefore constraining the hydrodynamic modelling

# Alternative Hydrochemical Approaches to Calculating Groundwater Mixing Proportions

**Posiva**

**JNC/Golders**

- Since different groundwater end-members are used, plus different criteria employed in calculating the mixing ratios, these approaches cannot be compared directly with the M3 calculations and therefore form separate studies within Task 5.

# Task 5: Alternative Hydrochemical Approaches (Posiva)

## ***Background:***

- The method is based on an inverse-modelling approach which is a combination of speciation modelling and mole balance modelling
- Providing constraints on the method is the speciation modelling, petrographic observations, reactions expected to dominate in the groundwater system, and groundwater isotopic data.
- The computations are handled by the PHREEQC-2 program

# Task 5: Alternative Hydrochemical Approaches (Posiva)

## *Input data:*

From palaeohydrogeological considerations a total of seven reference groundwaters have been identified which correspond to four, hydrogeochemically significant stages: Present, Litorina, Glacial and Preglacial. The reference groundwaters selected are:

- Meteoric
- Seawater
- Postglacial (seawater that has infiltrated bottom sea sediments)
- Litorina Sea (7 500-7 000 BP)
- Glacial Melt (Pleistocene)
- Preglacial Altered (deduced from Quaternary history)
- Saline (most saline sample at Äspö)



# Task 5: Alternative Hydrochemical Approaches (Posiva)

## ***Calculation procedure:***

- Basically, inverse modelling describes the chemical evolution of groundwater by giving exact estimates of the mixing and geochemical reactions among known initial water compositions needed for reaching a known final water composition
- The pre-investigation dataset (undisturbed) was used to identify the reference groundwater types that have been active at Äspö
- The tunnel impact dataset (disturbed) was used to monitor the effects of construction on the groundwater chemistry
- The calculations are carried out in steps, assuming steady-state chemical reactions

# Task 5: Alternative Hydrochemical Approaches (Posiva)

- The calculations are based on the assumption that Cl and  $^{18}\text{O}$  behave conservatively
- All other chemical values used in the calculations are subject to mole transfers - i.e. they are involved in dissolution/precipitation to/from reacting phases to satisfy the calculation constraints
- The directions of dissolution/precipitation reactions will move towards achieving steady-state conditions
- A previously successful step (assuming steady-state) will lead to the next step
- These steps ultimately extend to the reference waters, and then to the mixing fractions

# Task 5: Alternative Hydrochemical Approaches (Posiva)

## ***Conclusions:***

- Results show three extensive sources of groundwater that attempt to intrude into the Äspö site during open tunnel conditions
- These reference groundwater types are: Meteoric water, fresh Baltic Seawater and Saline groundwater.
- Geochemical reactions related to these types are strong (Baltic), moderate (Meteoric) and weak (Saline).

# Task 5: Alternative Hydrochemical Approaches (JNC/Golders)

## ***Background:***

Statistical PCA method based on a chemometric algorithm which makes no initial assumptions about the nature of the end-members present, and which considers all the contributions to chemical variability in the groundwaters.

# Task 5: Alternative Hydrochemical Approaches (JNC/Golders)

## ***Main conclusions:***

- The approach considers all groundwater chemical variability; seven principle components were employed
- The method distinguishes clearly between mixing and water-rock reaction processes
- Stable isotope and hydrogen isotope data are necessary to ensure an internally consistent model
- Tritium has a relatively large effect on the calculations because of its short half-life; variations in tritium may be explained by decay rather than by groundwater mixing

# Task 5: Alternative Hydrochemical Approaches (JNC/Golders)

- Inclusion or exclusion of extreme groundwater constituents or groundwater types has a significant effect on predictions
- The proportions of Brine in any groundwater are probably reliable
- Meteoric water does not seem always to be present at intermediate depths

# Task 5 Conclusions: General issues

- **Mixing ratio simulations based on M3 provided convenient means to integrate hydrochemistry and hydrogeology.**
- **The simulations showed that the results over the time period simulated (about 5 years) was sensitive to the boundary conditions of the “regional model” (2000x2000x1000m).**
- **Simulations suggested that the transport times from the vertical boundaries were shorter than the simulation time; thus the boundary conditions greatly influence the simulated chemical composition of the inflowing water to the tunnel.**
- **The reliability of the given boundary conditions was discussed at length, especially the western boundary, as it was mainly based on one deep borehole.**
- **Do the hydrochemical data represent conditions in the entire rock mass or mainly the most conductive features? i.e. how to interpolate reasonable initial and boundary conditions for just HCDs and HRDs.**
- **Below the sea the shortest transport timescales, i.e. approx. a month, indicate that the sampling programme in those cases was inadequate to record the dynamics of the system during tunnel construction.**
- **In some cases a full and direct comparison between groups was not possible due to different levels of ambition, achievement, available time and resources and model development.**

# Task 5 Conclusions: Groundwater Mixing Proportions

- Results essentially show M3 to be a good semi-quantitative tool to calculate mixing proportions and to present and interpret hydrochemical data.
- JNC/Golders' alternative modelling approach uses all the chemical variability of the dataset, thus increasing confidence in the quality of the calculated groundwater mixing proportions.
- Posiva's mixing proportion calculations using different end-members also provides a good alternative, in-depth approach.



# Task 5 Conclusions: Hydrodynamic Modelling

- Most groups were successful in calibrating and testing their respective models to simulate the Äspö groundwater flow conditions.
- Chemistry, in the form of single species or M3 mixing ratios, was used mainly to calibrate and modify properties of the Hydraulic Conductor Domains.

# Task 5 Conclusions: Hydrochemical Modelling

- All groups treated the groundwater mixing ratios in the hydrodynamic simulations as conservative, i.e. assuming no water/rock reactions.
- Hydrochemical modelling was attempted by six out of the nine groups.
- Hydrochemical reaction modelling, assuming thermodynamic equilibrium conditions, was carried out by four groups. Generally, this was successful and showed that reactions have some effect on the groundwater chemistry and therefore the calculated groundwater mixing ratios corresponded closer to the measured values
- However, geochemical reactions, whilst significant, are largely overshadowed when compared to mixing processes.

# Task 5 Conclusions: Integration

- Simple simulation of mixing ratios (+/- chemical reactions) was a base to calibrate (consistency check) the hydrogeological model
- Hydrochemical time-series data at the selected control points can reflect changes in the hydrodynamic flow conditions and be useful for calibration.
- Use of salinity (density) data to simulate large-scale hydrodynamic flow conditions was considered essential by some groups.
- Coupled flow and multicomponent reactive transport modelling was carried out by two groups; this is an area to be developed.

# Task 5 Conclusions: Understanding the Äspö Site

- The provided major HCDs, with one exception, appear to have been relevant and consistent concerning hydraulic responses. Shaft responses from the inflow indicated the absence of a fairly transmissive feature intersecting, or hydraulically well connected to, the shafts.
- A common approach was to derive a calibrated hydrodynamic model based on hydrogeology. This model was then used to predict the chemical distributions and then recalibrated to the measured chemical values by varying the fracture properties and boundary conditions.
- In some of the modelling carried out the travel velocity was poorly predicted. The chemical data provided the opportunity to refine these velocities.

- The use of geochemical data was required to calibrate the model, and aperture and storage parameters
- Confidence in a reliable hydrogeochemical conceptual model is another critical factor when initially deciding the boundary conditions to model the system.
- The future of hydrochemical integration is probably restricted to further refining its present use in the Task 5 modelling. For example:
  - helping to constrain initial and boundary conditions (i.e. conceptualism)
  - providing reference water mixing proportions for time-series samples collected at hydraulically strategic localities
  - using geochemical reaction modelling to further quantify the sample groundwater mixing proportions

# Conclusions: Site Characterisation Implications (1)

- Importance to have a sampling strategy in the regional scale to collect data for the definition of initial and boundary conditions with reasonable resolution, i.e.:
  - important to have good initial idea of processes to guide the sampling strategy
  - important to get undisturbed and representative groundwater samples (i.e. not disturbed by drilling or other borehole activities prior to sampling)
  - important to have a strategy for reasonable sampling time and space for “complete hydrochemical characterisation” and a denser sampling programme in space for a limited number of chemical species
  - identify possible conservative tracers that should be sampled systematically in space and time
  - hydrochemical and hydrogeological data from deep boreholes at some distance from the repository site may be essential for setting up a reliable regional descriptive geoscientific model that allows the interpolation and extrapolation of data to generate necessary boundary conditions in numerical groundwater/hydrochemical flow models

# Conclusions: Site Characterisation Implications (2)

- Importance to judge what can be considered as a large scale model (regional model?) to test a geoscientific model description in a similar way as Task 5.
- This has implications for the above issue to define initial conditions at the site and in the regional area.
- The first drilled boreholes are most likely to be distanced far enough apart to be unaffected by downhole investigations in the boreholes.
- However, when the boreholes are drilled more closely together, as will be the case in the later stage of siting the repository, a more mixed groundwater situation might be encountered due to hydraulic tests and other activities in the boreholes. At least some data might then be considered less valuable than the early samples.

# Conclusions: Site Characterisation Implications (3)

- Importance to have a sampling strategy during repository construction to collect data for the definition of the transient conditions with a reasonable resolution, i.e.:
  - try to take samples ahead of the tunnel excavation at a representative point near the tunnel; when the tunnel chainage has passed this point the sampling programme should be “complete” and intensive during the first months followed by a less frequent sampling programme. Time-series sampling at key points should be identified before excavation by evaluation of hydraulic simulations and the hydrogeochemistry description of the site
  - have a reasonable sampling programme of “complete hydrochemical characterisation” (or nearly the complete programme) at identified localities which are considered to be hydrodynamically connected to the key points along the tunnel
  - have a reasonable sampling programme of “complete hydrochemical characterisation” at identified points which are at some distance from the excavated tunnel system.



# Task 5: Modelling: Background perspective and Task 5 issues

- **Task 5 Modelling. Main objectives:**
  - to assess the consistency of groundwater flow models and hydrochemical mixing-reaction models through integration and comparison of hydraulic and chemical data obtained before and during tunnel construction  
*Have met objective - but can still be improved!*
  - to develop a procedure for integration of hydrological and hydrochemical information which could be used for disposal site assessments  
*Partly successful - but still much to be done!*

- **Task 5 Modelling. Performance measures:**

- To facilitate comparison and integration of hydrological and hydrochemical, a series of control points were identified along the tunnel
- Based on these locations, a series of measures were identified to check the performance of the models:

- the nature of the groundwater flow pattern through the bedrock to the tunnel control points

*Partly accomplished by some groups*

- the advective groundwater travel time distribution to the control points,

*Not clearly indicated in the reporting!*

- the nature of the groundwater chemical evolution to explain the results at each control point

*Accomplished by some groups*

- **Task 5 Modelling. Aims:**

- Model calibration along tunnel length 0-2900 m based on available data from the pre-investigation and construction phases

*Accomplished by all groups but at different levels of ambition!*

- Model predictions of construction phase disturbance along tunnel length 2900-3600 m was based on inflow groundwater data from the entire tunnel section; no hydrochemical data were released

*Accomplished by all groups but at different levels of ambition.*

*Up-dating of model parameters based on all data was not always clear.*

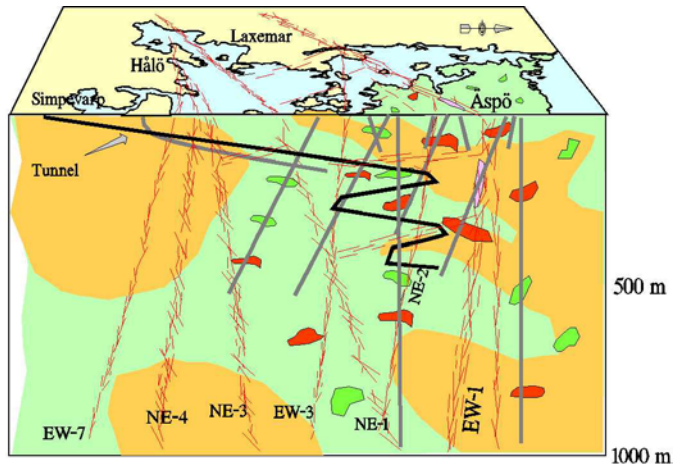
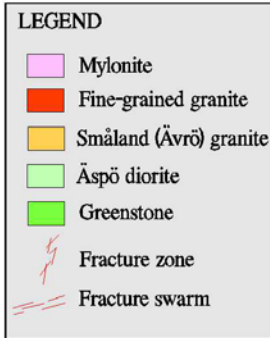
# Task 5. Future Steps for Summary and Review Reports

- **Summary Report:**
  - Modellers should read their 'Table Columns' in the report and appendices carefully and give comments no later than October 10th
  - Read and give overview comments of the rest of the report
  - JS and IR to produce a more complete draft
  - Final review by the modellers and Task Force delegates
- **Review Report**
  - Read and give overview comments of the report
  - Wait for a more final draft of the complete summary report
  - AB and PJ to produce a more complete draft
  - Final review of the modellers and Task Force delegates

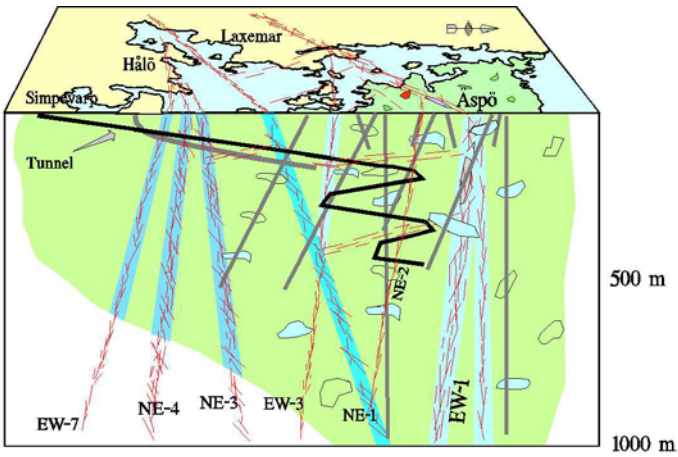
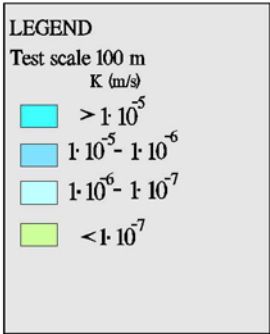
## **Appendix F**

**Summary report - Chemistry**  
**J. Smellie (Conterra)**

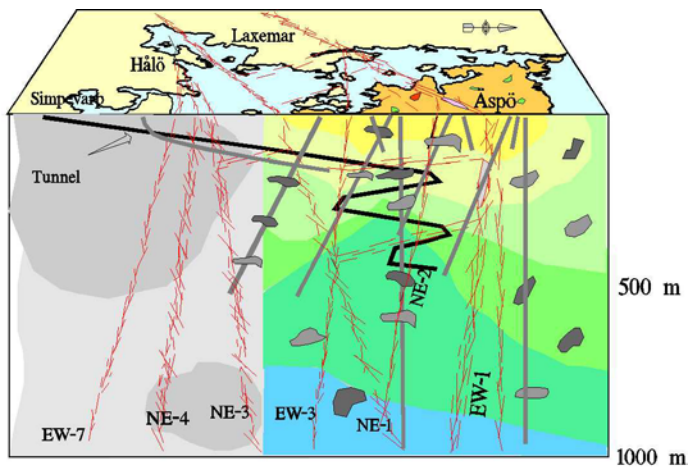
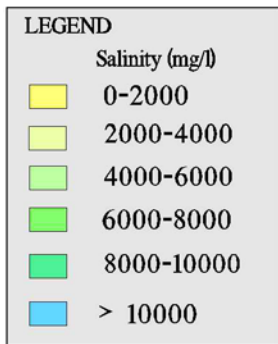
### GEOLOGY



### HYDROGEOLOGY



### CHEMISTRY











Model characteristics	ANDRA / ANTEA	ANDRA / CEA	ANDRA / ITASCA	BMWi / BGR	CRIEPI	ENRES A/ UDC	JNC / GOLDER	POSIVA / VTT	SKB/ CFE/ Intera (1)	SKB/ CFE/ Intera (2)
<b>Boundary conditions - Top – Sea :</b> Increased conductivity uppermost layer Sea-bed “skin”	X?		X				X		X X	X X
Hydrostatic head	X	X X?	X	X	X	X	X	X X	X X	X X
Sea salinity	X	X	X	X	X	X	X	X(1) X(2)	X	X
<b>Baltic Sea Inverse modelling results</b>										
<b>Boundary conditions - Sides</b> Hydrostatic head			X	X	X	X		? ?		
Head from regional model – constant	X						X			
Head from regional model – f(time)		X?							X	X
Salinity from regional model – f(time)		X?							X	X
<i>Mixing ratios – constant</i>		X	X	X	X	X	X(1,2)	X(1)	X	X
<i>Mixing ratios – f(time)</i>	X									
<i>Chemical composition derived from obs.</i>							X(3)			
<i>Inverse modelling results</i>								X(2)		

Model characteristics	ANDRA / ANTEA	ANDRA / CEA	ANDRA / ITASCA	BMW / BGR	CRIEPI	ENRES A/ UDC	JNC / GOLDER	POSIVA / VTT	SKB/ CFE/ Intera (1)	SKB/ CFE/ Intera (2)
<b>Boundary conditions – Bottom :</b> No flow Hydrostatic head Head from regional model – constant Head from regional model – f(time) Salinity from regional model – f(time) <i>Mixing ratios – constant</i> <i>Mixing ratios – f(time)</i> <i>Brine salinity</i> <i>Inverse modelling results</i>	X	X	X	X	X	X	X	? ? ?	X X	X X
<b>Boundary conditions–Tunnel and shafts</b> Specified flow = f(time) Tunnel “skin” (eff. of grouting or geom.) Atmospheric pressure Specified head	X	X X	X	X	X	X X	X	? X	X	X

**Table 4-2. Summary of the use of hydrochemistry by the different modelling groups**

	ANDRA/ANTEA	ANDRA/CEA	ANDRA/ITASCA	BMW/BGR	CRIEPI	ENRESA/UDC	JNC/GOLDER	POSIVA/VTT	SKB/CFE/Intera
Use of M3-calculated groundwater mixing ratios	Yes	Yes	Yes	Yes	Yes	Yes	Yes	Yes	Origin of M3 <sup>1</sup> (Mixing and Massbalance Model)
Alternatively-calculated groundwater mixing ratios	No	No	No	Yes, recalculated using PHREEQC with Cl, Na and <sup>18</sup> O acting as conservative tracers.	Yes, using the FEGM/FERM coupled code for groundwater flow and solute transport	No	Yes, Principle Component Analysis (PCA). Model uses a chemometric algorithm <sup>2</sup>	Yes, inverse geochemical modelling using PHREEQC-2	No
Influence of chemical reactions	Not considered	Not considered	Yes, using the FLO code based on principle components and assuming thermodynamic equilibrium	Yes, geochemical thermodynamic equilibrium modelling using PHREEQC	Yes, geochemical thermodynamic equilibrium modelling using PHREEQE	Not considered	Yes, qualitative indication of reactions using PCA.	Yes, inverse geochemical modelling using PHREEQC-2 <sup>3</sup>	Yes, qualitative indication of reactions using M3 and Voxel 3D interpolation.
<u>Chemical reactions of importance</u>  - HCO <sub>3</sub> production caused by decomposition of organic material in meteoric water	Not considered	Not considered	Not considered	Significant	Significant	Not considered	Significant; suggested microbial processes	Significant	Significant
				Significant	Not		Not indicated	Yes,	Both yes and

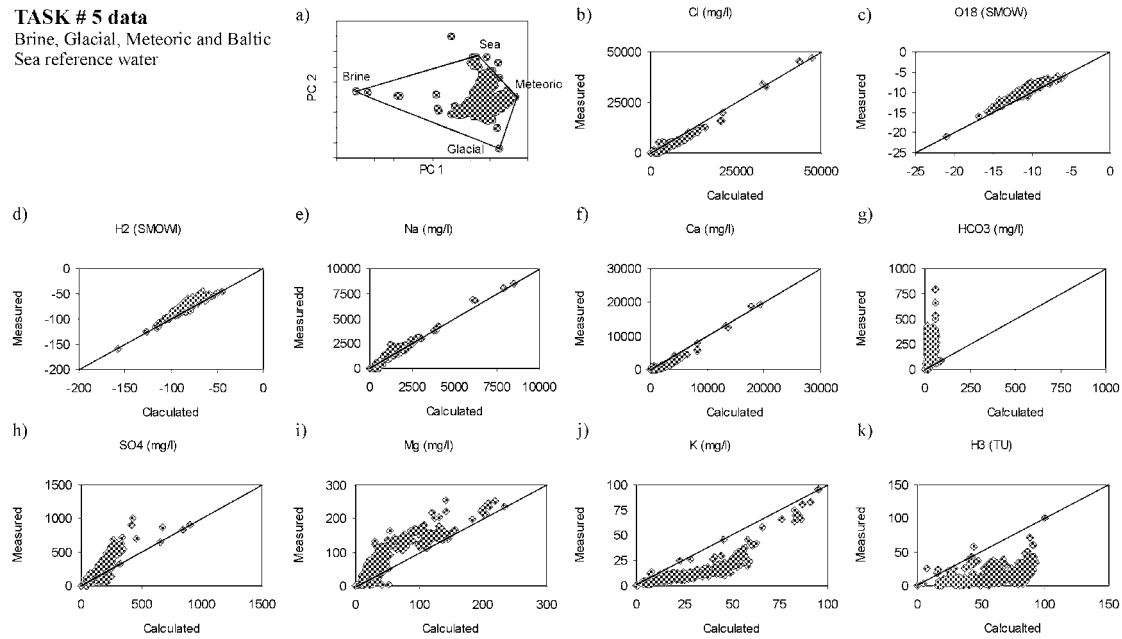
	ANDRA/ANTEA	ANDRA/CEA	ANDRA/ITASCA	BMW/BGR	CRIEPI	ENRESA/UDC	JNC/GOLDER	POSIVA/VTT	SKB/CFE/Intera
- Consumption of dissolved oxygen in meteoric water by pyrite oxidation			Not considered	Significant	significant		Not indicated	dissolution of goethite under undisturbed conditions	no depending on site location
- Precipitation and dissolution of calcite			Significant	Significant; loss of K, gain of Mg and Na	Not significant		Significant; suggested exchange of Ca/Na for Mg/K	Significant	Significant
- Cation exchange by clay minerals			Not considered	Significant	Significant		Not indicated	Yes, Na-Ca; Na-Mg; Na-Fe	Both yes and no depending on site location
- Oxidation-reduction between HS <sup>-</sup> and SO <sub>4</sub> <sup>2-</sup>			Not considered		Not significant			Significant; pyrite precipitation	Both yes and no depending on site location

<sup>1</sup> = Laaksoharju et al. (1999)

<sup>2</sup> = Cave and Wragg (1997)

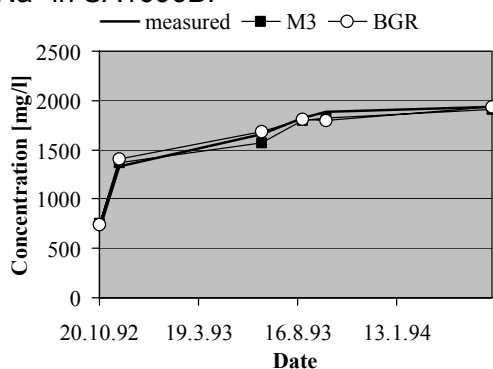
<sup>3</sup> = Pitkänen et al. (1999)

**TASK # 5 data**  
Brine, Glacial, Meteoric and Baltic  
Sea reference water

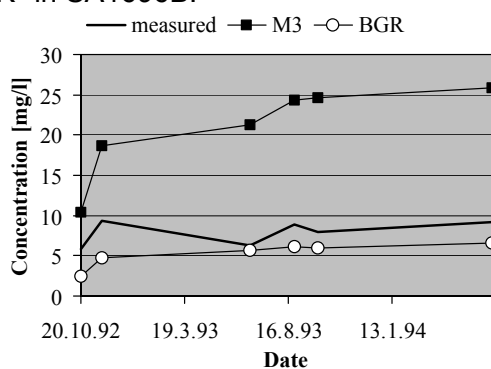


**Figure 4-2:** The TASK#5 groundwater is modelled to be a mixture of Brine, Glacial, Meteoric and Baltic Sea reference waters as shown in the PCA (Figure a). The calculated values based on the mixing proportions and the element contribution from reference waters are compared with measured values for different groundwater constituents (Figures b-k). If the value is on the line the predicted and measured value coincide, if the value is above/under the line there is a deviation between the measured and predicted values. A deviation from the line for the water conservative elements such as Cl, oxygen-18 ( $^{18}\text{O}$ ) and deuterium ( $^2\text{H}$ ) indicates scatter in the model. A deviation for a reactive element such as carbonate ( $\text{HCO}_3$ ) can indicate gain (values over the line) or losses (values under the line) associated with reactions.

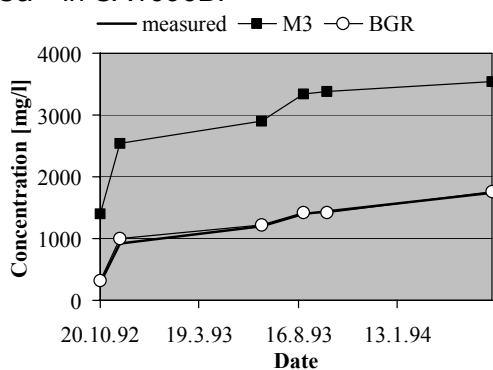
Na<sup>+</sup> in SA1696B:



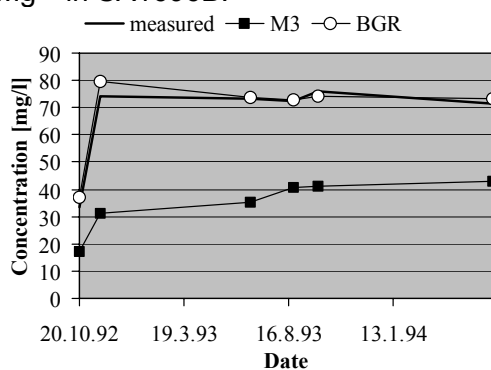
K<sup>+</sup> in SA1696B:



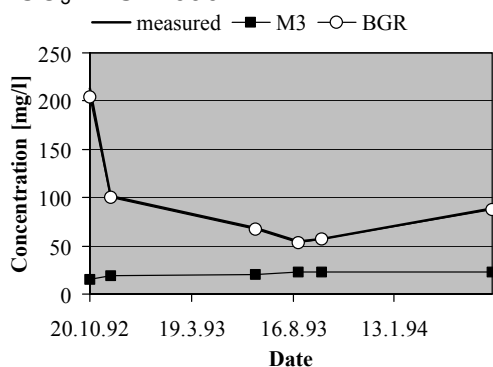
Ca<sup>2+</sup> in SA1696B:



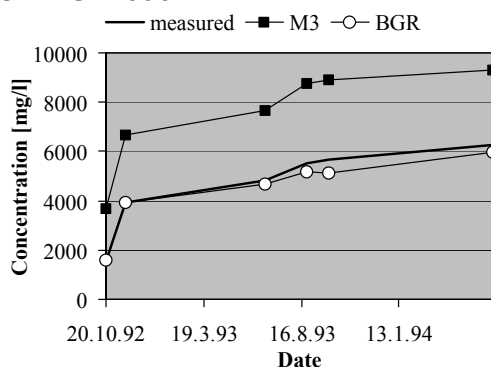
Mg<sup>2+</sup> in SA1696B:



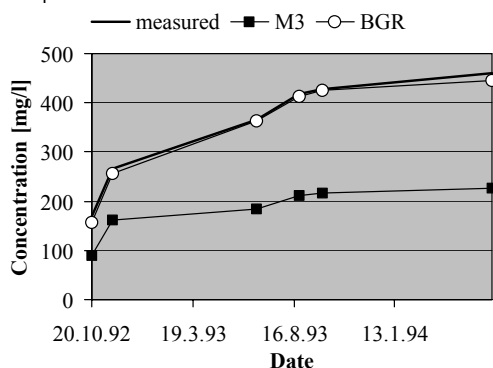
HCO<sub>3</sub><sup>-</sup> in SA1696B:



Cl<sup>-</sup> in SA1696B:



SO<sub>4</sub><sup>2-</sup> in SA1696B:



<sup>18</sup>O in SA1696B:

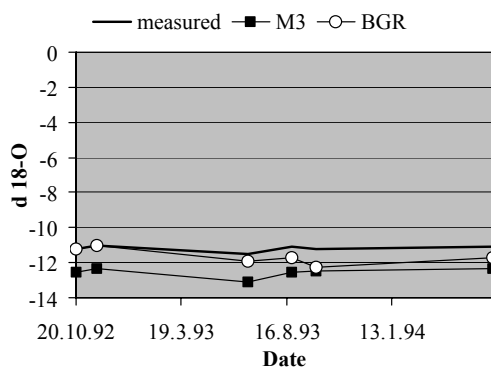


Figure 8-10 Measured element concentrations in borehole SA1696B compared to a mixing-equilibration approach.

## **Appendix G**

**Task 5 Reviewer report**  
**A. Bath (Intellisci) and P. Jackson (Serco)**



# **Review of Task 5: Coupling Geochemistry and Transport**

Adrian Bath\* and C Peter Jackson<sup>¶</sup>

\* Intellisci, UK

<sup>¶</sup>Serco Assurance, UK

# Scope of Review

- Participate in interim meetings & reporting
- Review individual participant reports
- Compare actual procedures with Task plan
- Review approach of participants
- Evaluate outcome of integrating information
- Review process for geochemical data
- Discuss general issues of the overall method

# Summary of Review (1)

- Impressive work, large step forwards in integrating geochemistry with large scale transport model
- General approach is good, but range of detailed variations makes Task #5 difficult to understand
- Process for using geochemical data has additional uncertainties

## Summary of Review (2)

- Measures for comparing models and data need to be established
- Uncertainties are generally underestimated
- Results indicate broad non-uniqueness in resulting transport model

# Structure of Review Report

- Introduction and organisation of Task #5
- Approach to hydrochemical input
- Work by participants
- Discussion of general issues

# Introduction and Organisation of Task #5

- Aims and approach to achieving aims
- Implementation plan
- Participating modelling groups
- Input data deliveries
- Summary of types of models used
- Producing Summary and Review reports

# M3 Approach

- Step-by-step process to calculate mixing fractions
  - Principal Component Analysis of all data
  - Identification of reference waters from M3 plot
  - Determine mixture of reference waters that is equivalent to each sample
  - Determine deviations from non-reactive mixing and interpret as reactions

# Work by Participants

- Key points of individual approaches to Task #5
  - e.g. aims, limitations, model methods, assumptions, flow/transport model, calibration, particle tracking, geochemical reactions
- Specific comments on each approach
  - not comprehensive
  - appraisal: understandable, special aspects, justification, alternative interpretations?



# Discussion of General Issues

- Has Task #5 been useful?
- Procedures – how the task was carried out
- M3 method for geochemical data
- Models: conceptual and numerical
- Uncertainties, sensitivity analysis & uniqueness
- Initial conditions in the model domain
- Presentation

# 1. Has Task #5 been useful?

- A significant step forwards!
- Aspo offers a great opportunity for this
  - unique degree of site characterisation
  - large data sets are available
- Impressive adaptability of numerical models
- Realistic test of method for a disturbed system

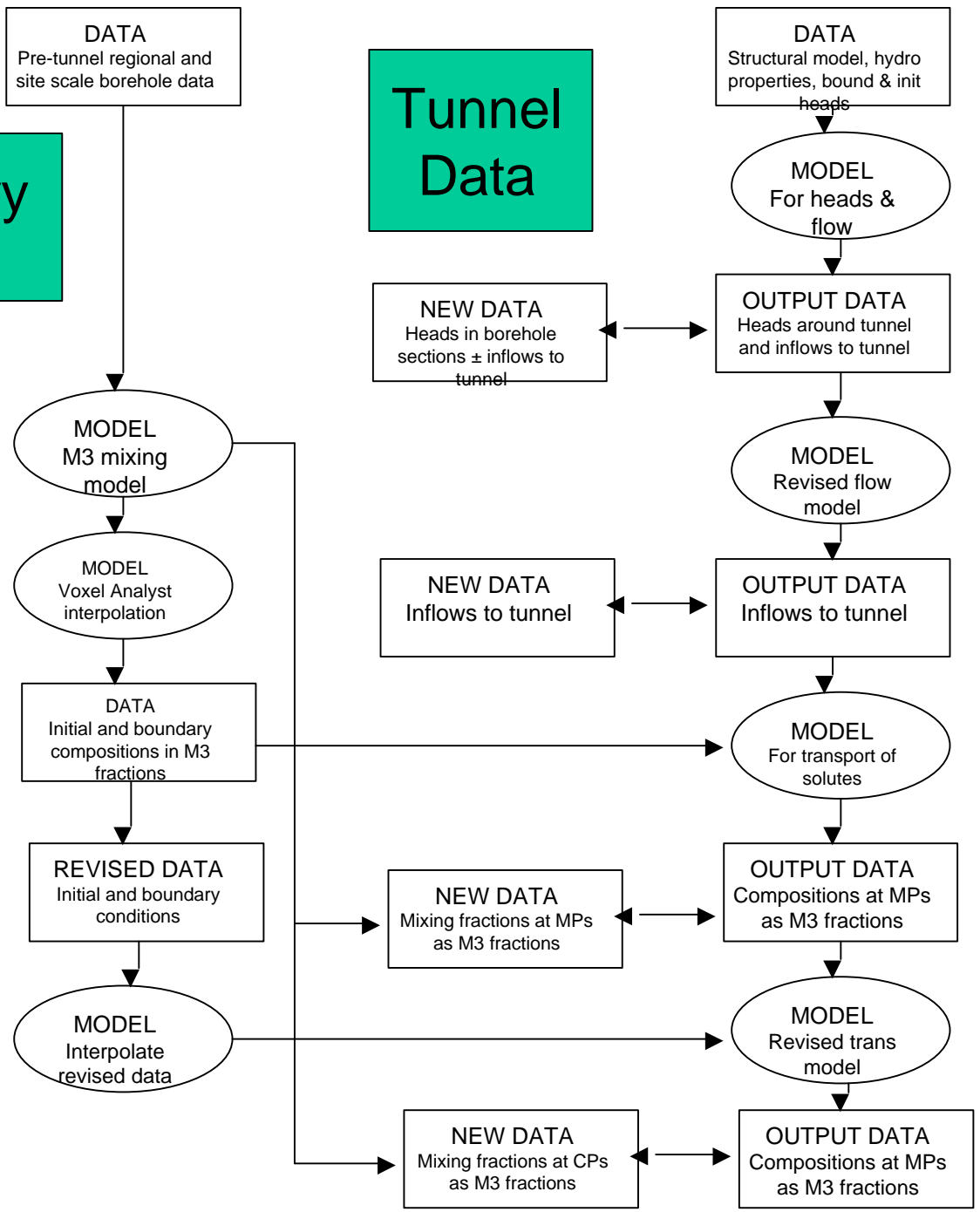
## 2. Procedures – How the Task was carried out

- Work deviated from the original plan
- General consistency, with many detailed variations
- Calibration-testing procedure is not clear in many cases
- ‘Goodness of fit’ measures were needed
- Ideally the target would be the ‘range of acceptable models and parameters’
  - Are ‘blind’ predictions a useful approach?

# Chemistry Model

# Tunnel Data

# Hydraulic Model



## 2. Procedures – How the Task was carried out

- Work deviated from the original plan
- General consistency, with many detailed variations
- Calibration-testing procedure is not clear in many cases
- ‘Goodness of fit’ measures were needed
- Ideally the target would be the ‘range of acceptable models and parameters’
  - Are ‘blind’ predictions a useful approach?

# What are appropriate criteria for comparison of models and data?

- generally, no criteria were used
- some models minimise residuals
- we propose  $\pm 5-10\%$  on head change and on inflows as reasonable targets
- step-changes and general directions of change are also important matching criteria

## 2. Procedures – How the Task was carried out

- Work deviated from the original plan
- General consistency, with many detailed variations
- Calibration-testing procedure is not clear in many cases
- ‘Goodness of fit’ measures were needed
- Ideally the target would be the ‘range of acceptable models and parameters’
  - Are ‘blind’ predictions a useful approach?

### 3. M3 Method in Task #5

- M3 is a valuable tool for visualisation
- Simple way of capturing data – advantages and disadvantages for presentation etc
- Additional uncertainties in mixing fractions relative to using individual constituents
- Prescription for mixing fractions gives concerns about transporting the fractions



## Alternatives for Using Geochemical Information in Task #5

- M3 visualisation with only non-reactive parameters
- JNC-Golder use another PCA method to obtain chemical components
- Posiva-VTT interpret mixing-reactions by inverse modelling
- Various groups have transported non-reactive solutes (Cl) and isotopes ( $\delta^{18}\text{O}$ )

## 4. Models

- Geometry and flow concepts are similar but the simplifications vary
  - HCDs, planar/channels, HRD, density
- Differences in output indicate biases and numerical issues
  - recharge, constant boundaries, variability in HCDs
- All models are ‘reasonable’ approximations

## 5. Uncertainties, sensitivity analysis & uniqueness

- Systematic sensitivity analyses would have increased understanding
- Also, identifying parameters and features to which the model is insensitive
  - Task #5 doesn't test these – other experiments?
- Results from many models provide a first view of non-uniqueness and sensitivity
  - In some aspects, but also other factors

# Sensitivity tests by ANTEA

<i>Parameter</i>	<i>Change</i>	<i>Max effect at CP1 (abs change in % M3 fraction)</i>
Fracture permeability	x10 or x10 <sup>-1</sup>	58% change in meteoric 28% change in brine
Kinematic porosity	x10 or x10 <sup>-1</sup>	58% change in meteoric 32% change in brine
Dispersivity	x2 or x0.5	60% change in meteoric 32% change in brine
Head boundary	init? or 0 masl	56% or 42% in meteo 18% in glacial

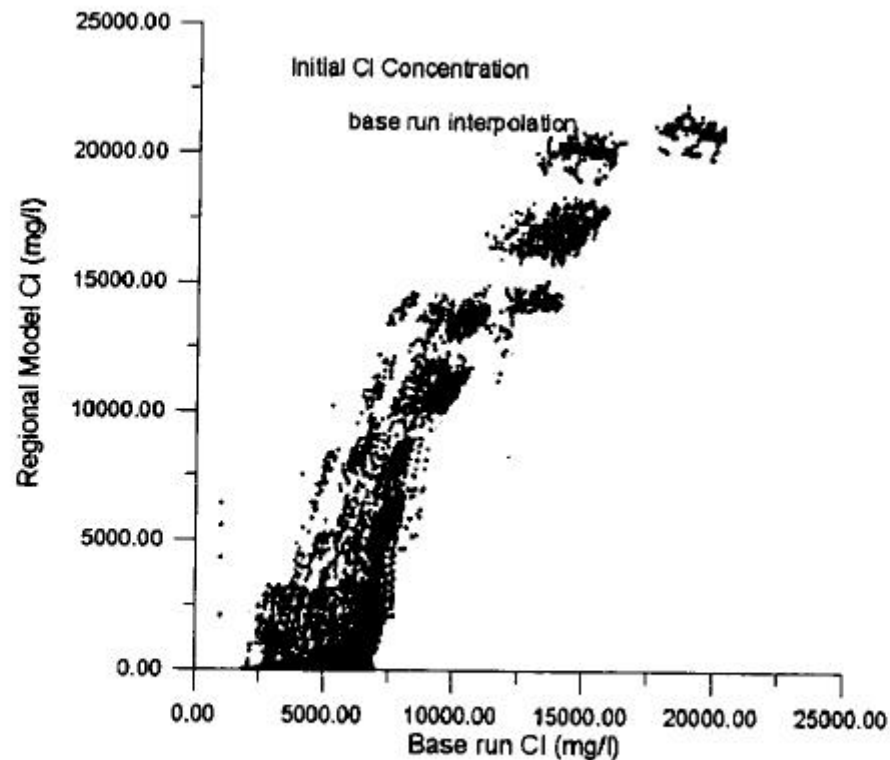
## 5. Uncertainties, sensitivity analysis & uniqueness

- Systematic sensitivity analyses would have increased understanding
- Also, identifying parameters and features to which the model is insensitive
  - Task #5 doesn't test these – other experiments?
- Results from many models provide a first view of non-uniqueness and sensitivity
  - In some aspects, but also other factors

## 6. Initial Conditions (1)

- They dominate the outcome of the transport model
- Interpolation is very uncertain, ‘expert judgement’ may bring it closer to reality
- Sensitivity to initial conditions is mixed up with uncertainty in transport properties, i.e. matrix storage, storativity, kinematic porosity, dispersivity

# Comparison of modelled chloride for different initial conditions (UdC)



Regional Model initial concentrations (X) versus base run initial concentrations (Y).

## 6. Initial Conditions (1)

- They dominate the outcome of the transport model
- Interpolation is very uncertain, ‘expert judgement’ may bring it closer to reality
- Sensitivity to initial conditions is mixed up with uncertainty in transport properties, i.e. matrix storage, storativity, kinematic porosity, dispersivity

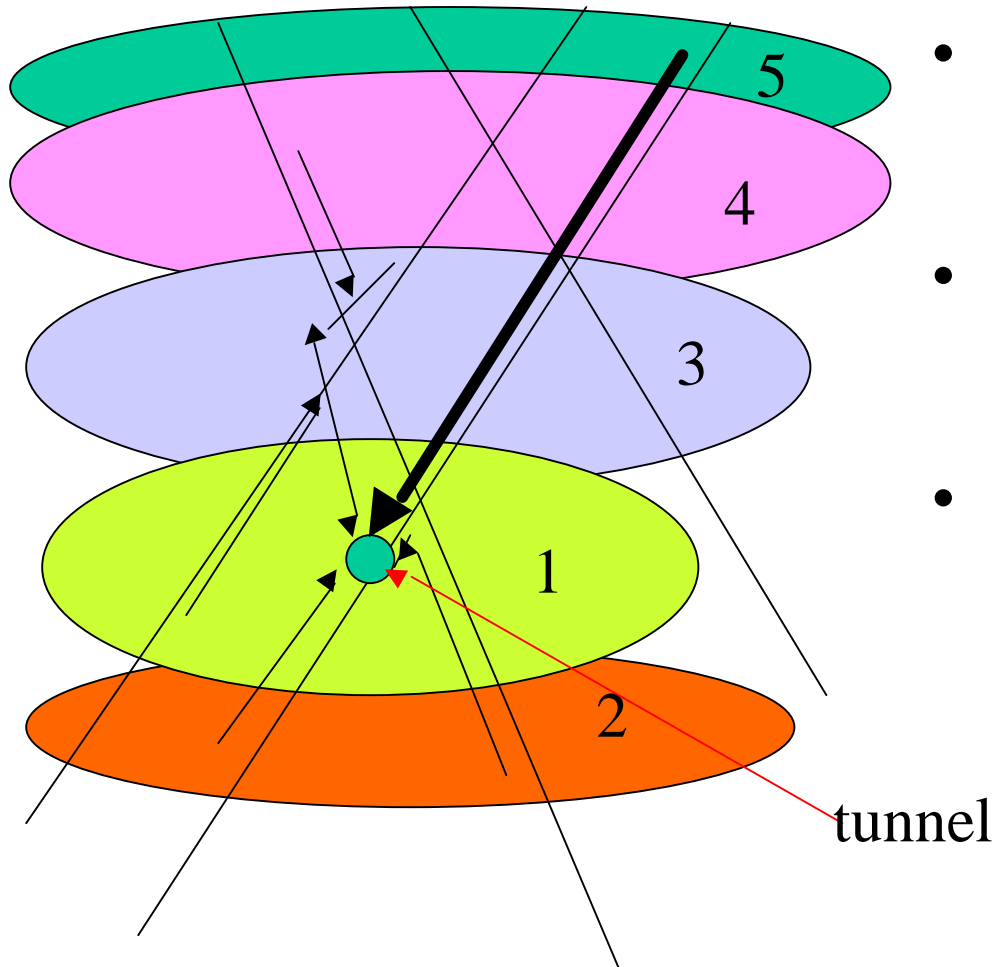


## 6. Initial Conditions (2)

- Testing consistency of geochemical data with the transport model depends critically on knowledge of the initial conditions
  - this could be a requirement for data acquisition in a site investigation

# Example

(the coloured ovals represent a vertical system of water masses  
With different compositions)



- Homogeneous flow should evolve  $1_{2\&3} - 4 - 5$
- Matrix storage should affect mass budget of 1 and delay 2&3
- Sparse anisotropic fracture network and/or hetero-geneous properties could give e.g.  $1 - 5$

## Two further points

- It's not possible to confirm that geochemical data have reduced the range of acceptable models
- Model for site PA is different from model for disturbed system at a URL

# General applicability for site investigation and PA

- Is site evolution or PA flow system being modelled?
- This determines required boundary and initial information and data acquisition strategy

## 7. Presentation

- Choices of parameters are not all physically realistic – justification and reality checks needed!
- Assessments of uncertainties and ‘goodness of fits’ are generally optimistic or uncritical: this works against the preferred strategy of progressively reducing uncertainty

# Finally.....

- Understanding data sources would be helped by a 3D visualisation of borehole locations etc
- Are these reports the best format for communicating and comparing results? – Standardised data tables, figures, explanatory information, etc would help

## Appendix H

T6C Introduction  
J-O Selroos, (SKB)

# TASK 6

## Task Force meeting #15

### Goslar

- Task 6 provides a bridge between Site Characterization and PA models.
- Two spatial scales (single fracture and fracture network).
- Two temporal scales (experimental and PA).
- Task 6A: single fracture, exp. time scale.
- Task 6B: single fracture, PA time scale.



# Task 6: Objectives

- Assess simplifications used in PA models (key PA assumptions, PA model components of a site, rationale for simplifications in PA models, benchmark for comparison of PA and SC models, transfer of SC models to PA models using site data).
- Assess the constraining power of tracer and (flow) experiments for PA models.
- Provide input for site characterization programs from a PA perspective.
- Understand the site-specific flow and transport behaviour at different scales using SC models.

# Task 6A

- Purpose of Task 6A is to provide a common basis for future comparison.
- Task 6A consists of modelling selected tracers in the STT-1b test configuration of TRUE-1.
- Difference relative to Task 4E: Tracers (Tc-99, Am-241), knowledge of increased retention in field compared to lab.
- Experimental and Dirac pulse input, simplified performance measures.

# Task 6B

- STT1-b test adjusted to PA temporal conditions (same flow path, 1000 times lower velocity).
- Same tracers as in Task 6A.
- Constant injection and Dirac pulse input, simplified performance measures.
- Possible Task 6B' should be discussed at TF#15 (=Task 6B but with realistic PA boundary conditions).

## Appendix I

T6DE Issues  
J-O Selroos, (SKB)

# Task 6 Workshop

## Goslar

### September 10, 2001

- Agenda
- Objectives
  - Present and discuss framework for obtaining structural model for Tasks 6 D&E
  - Definition of Tasks 6 D&E revisited

# TASK 6

## Task Force meeting #15

### Goslar

- Task 6 provides a bridge between Site Characterization and PA models.
- Two spatial scales (single fracture and fracture network).
- Two temporal scales (experimental and PA).
- Task 6D: fracture network, exp. time scale.
- Task 6E: fracture network, PA time scale.

# Task 6D

- Purpose of Task 6D is to provide a common reference platform and to ensure a common basis for Task 6E.
- Task 6D consists of modelling selected tracers in a configuration similar to TRUE Block Scale.
- A 50-100 m block scale synthetic structural model is needed (based on data from TRUE BS, Prototype repository, FCC, TRUE-1 block).
- Tracer input and performance measures need to be defined.

# Task 6E

- Purpose of Task 6E is to extend Task 6D transport calculations to a set of PA time scales and boundary conditions (first base case, then possible alternative assumptions).
- Task 6E consists of modelling selected tracers on a 50-100 m scale (same structural model as in Task 6D), but with PA boundary conditions.
- A 50-100 m block scale synthetic structural model is needed (based on data from TRUE BS, Prototype repository, FCC, TRUE-1 block).
- Tracer input and performance measures need to be defined.



# Tasks 6 D&E

## Open issues and questions:

- Definition of structural model (Task 6C): as realistic as possible or generic?
- How should boundary conditions for flow be defined (may have strong impact on what part of model is accessed by tracers)?
- How should boundary conditions for transport be defined (where/what type of fracture should source be located in)?
- Possibility to compare results to experiments (TRUE BS) or previous PA studies (SR 97).

# Tasks 6 D&E

## Open issues and questions (cont.):

- Where should breakthrough be monitored?



# Requirements on structural model:

- Should contain main geologic and hydraulic characteristics of Äspö site.
- Transport properties relevant for short term and long term transport processes should be defined and parametrized (micro-structure).
- Should contain features/fractures where source term can be realistically placed.
- Should be possible to assign both experimental and PA type boundary conditions.

## Appendix J

Models used for T6A&B in 2D and 3D  
L. Moreno (CE-KTH/SKB)

# Predictions of the strongly sorbing tracer tests using independent data

**L. Moreno, I. Neretnieks**

**Chemical Engineering and Technology**

**Royal Institute of Technology**



KTH

---

**Chemical Engineering and Technology**

# BACKGROUND

- **Sorbing and non-sorbing tracer tests were performed at Äspö, TRUE-1**
- **Results from non-sorbing tracer tests were used for calibration ( $t_w$  and dispersion)**
- **Sorbing tracer tests were predicted**



# Solute Transport Model

- For a Channel

$$\frac{C}{C_o} = \text{erfc} \left( \frac{L}{\sqrt{D_e K_d \rho \theta}} \sqrt{\frac{t - t_w}{\theta}} \right) \frac{LW}{Q}$$

- For strongly sorbing species

- Basic entities

$$D_e K_d \rho \text{ and } \frac{LW}{Q}$$

- Secondary entity

$t_w$ , Water Residence Time



KTH

# AIM

- **To predict the sorbing tracer tests using only field and laboratory data**

- **Laboratory (field) data:**

$D_e$   $K_d$   $\rho$

- **Field data:**

- » **Flow Wetted Surface, FWS**
- » **Flow distribution,  $f(Q)$**
- » **Actually FWS/ $Q$  distribution**



KTH

Chemical Engineering and Technology



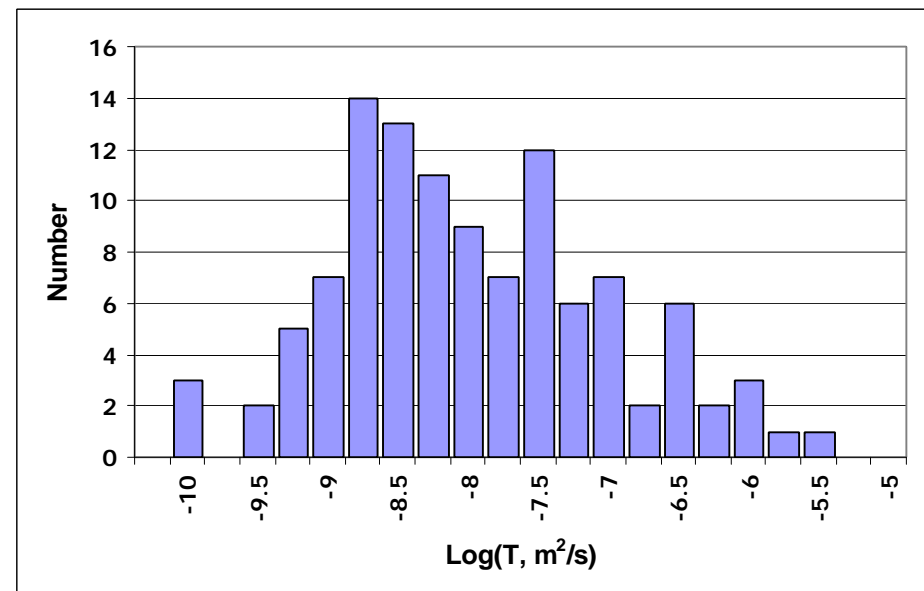
# Flow Wetted Surface, FWS

- **Data with 0.5 m packer distance**
- **30 % of the sections show inflow below detection level**
- **Average fracture frequency was 2 fracture per metre**
- **FWS estimated to be about 8 m<sup>2</sup>/m<sup>3</sup> rock**



# Transmissivity Distribution

- **Five boreholes with 162 0.5-m sections**
- **The standard deviation in transmissivity is about 1.00**



KTH

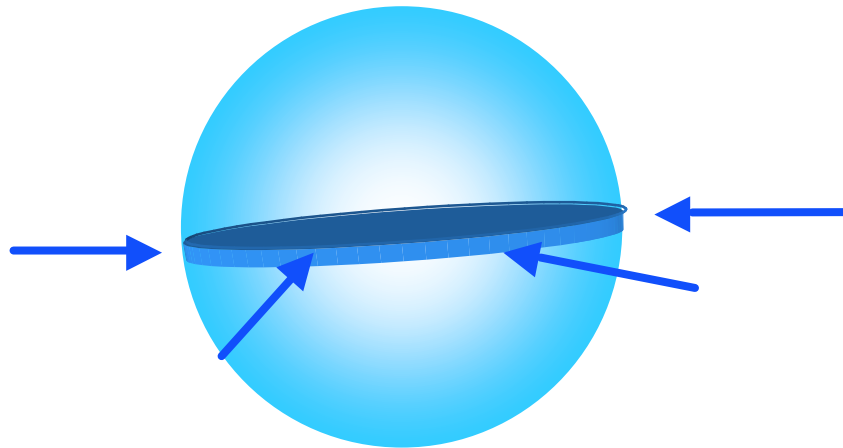
# FWS/Q

- **For converging tracer tests,  $Q$  is the extraction rate**
- **FWS is the surface area that this flow comes in contact with**
- **For TRUE1, FWS depends on the assumption made for flow geometry.**
- **We assume 3-D flow around extraction hole**

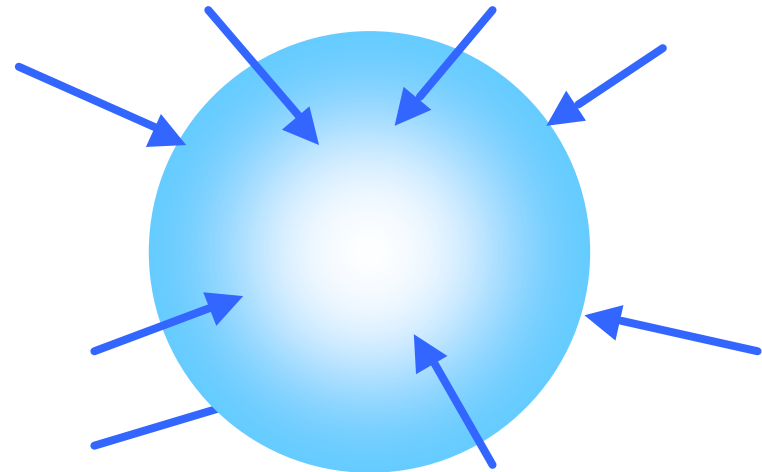


# FWS in 2-D and 3-D flow structures

- **FWS: 157 m<sup>2</sup>**



**FWS: 4533 m<sup>2</sup>**



KTH

Chemical Engineering and Technology

# Other Used Data

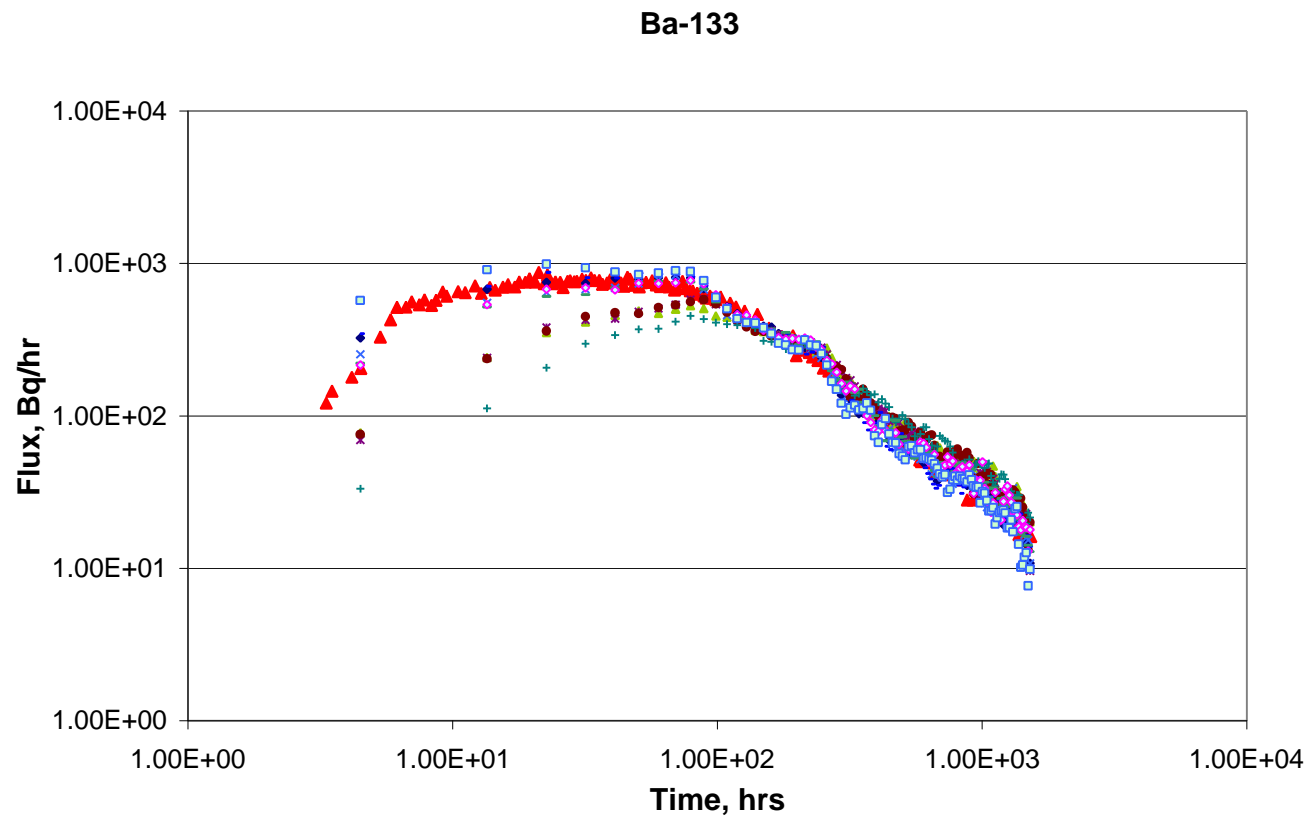
## – Rock data

- » Porosity of matrix = 0.004
- » Rock density = 2700 kg/m<sup>3</sup>
- » Pore Diffusivity = 2•10<sup>-11</sup> m<sup>2</sup>/s

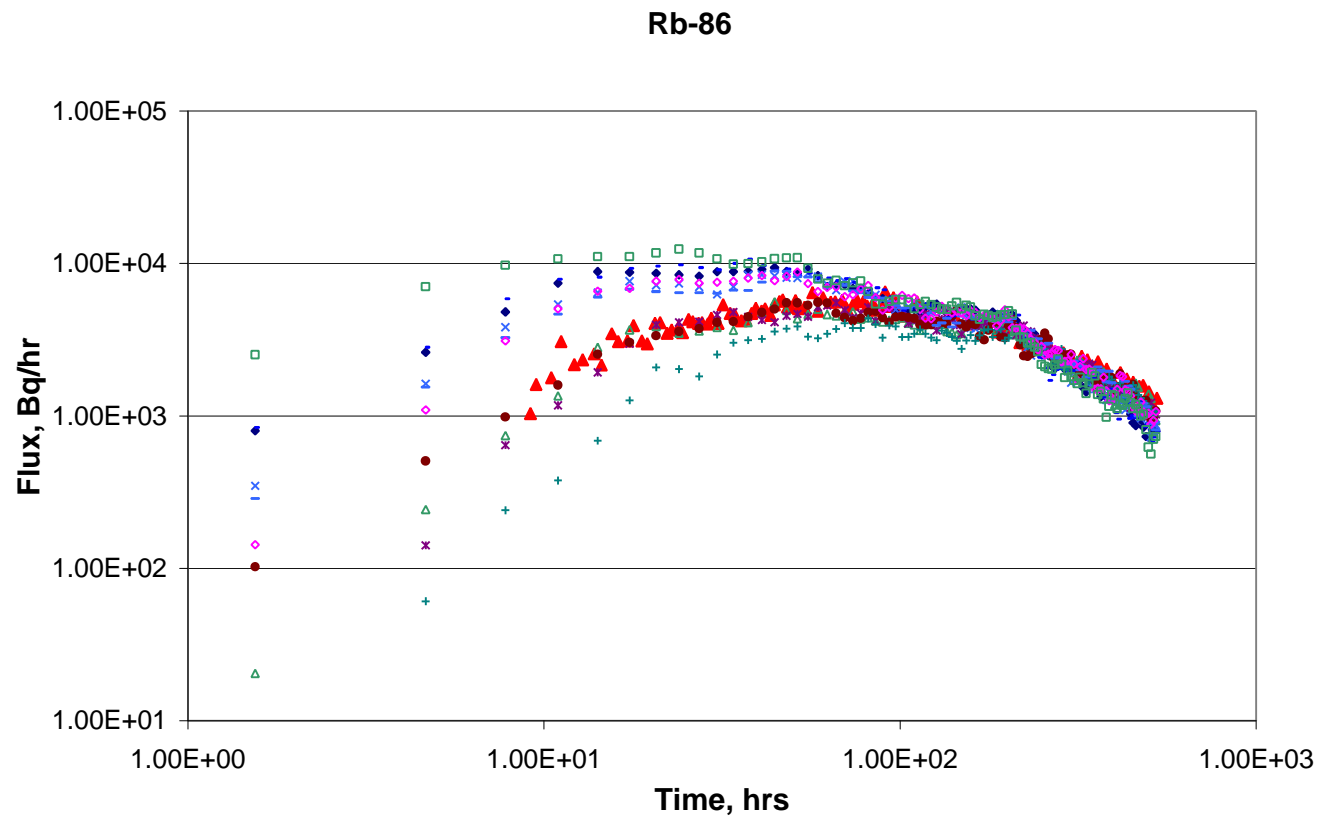
Species	Sorption Constant $K_d, \text{m}^3/\text{kg}$	Flow Wetted Surface, $\text{m}^2/\text{m}^3$
Ba	0.005	
Cs	0.400	8.0
Rb	0.008	



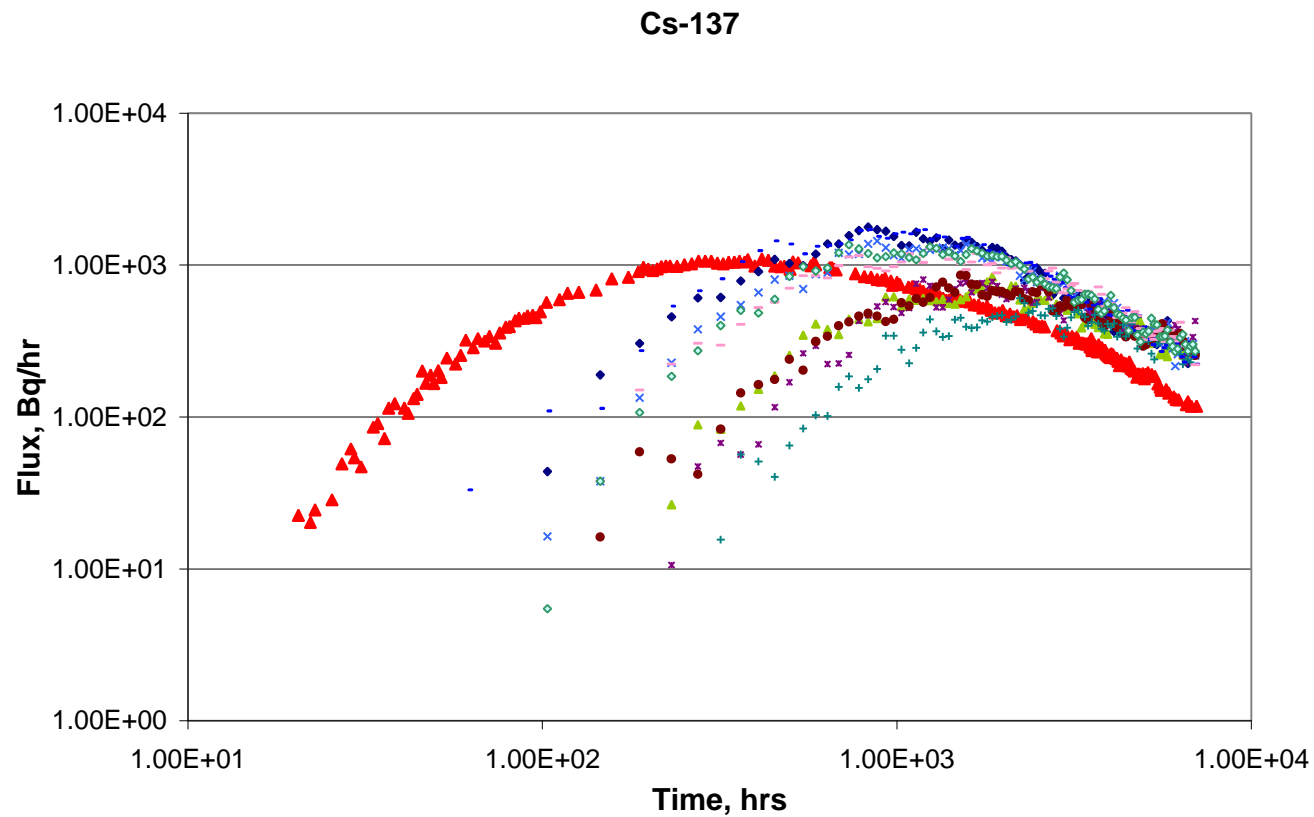
# Prediction for Ba-133 using CHAN3D



# Prediction for Rb-86 using CHAN3D

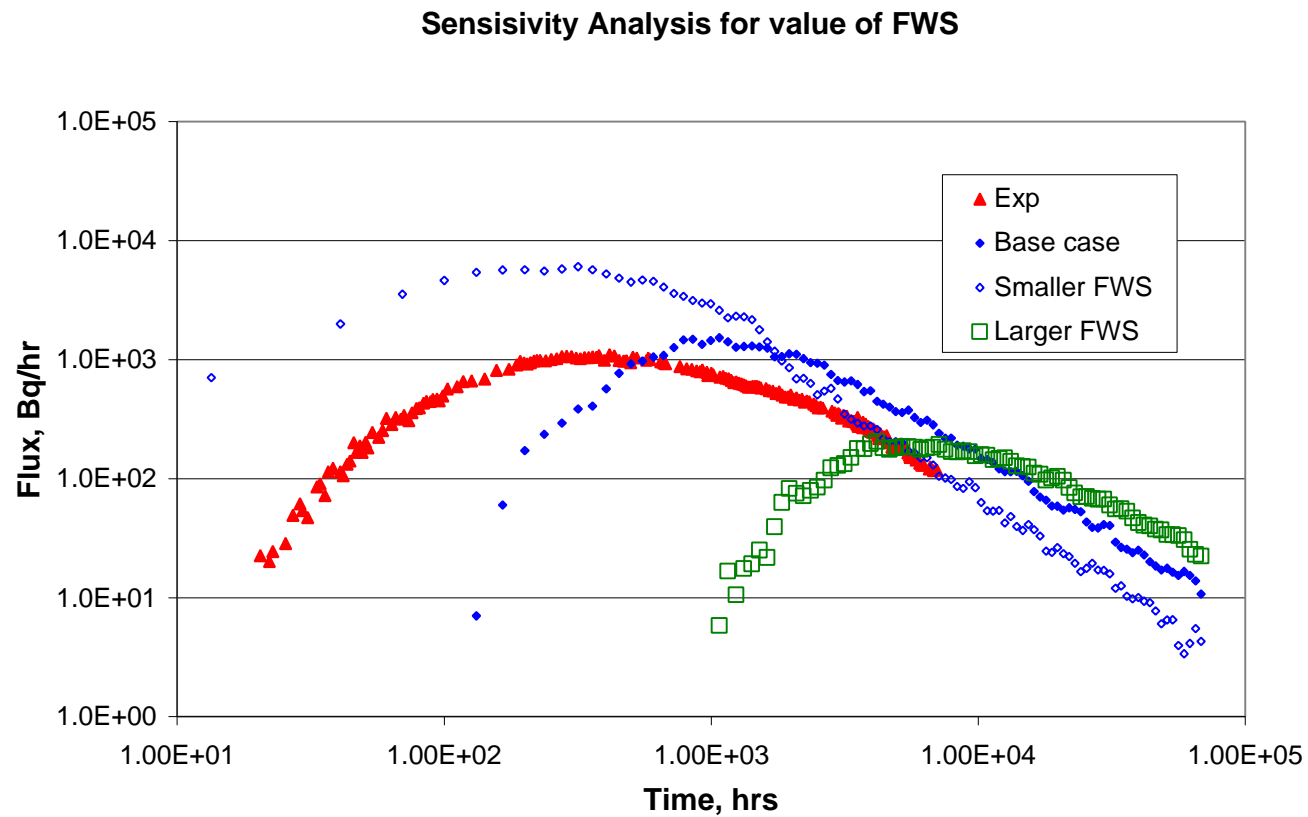


# Prediction for Cs-137 using CHAN3D

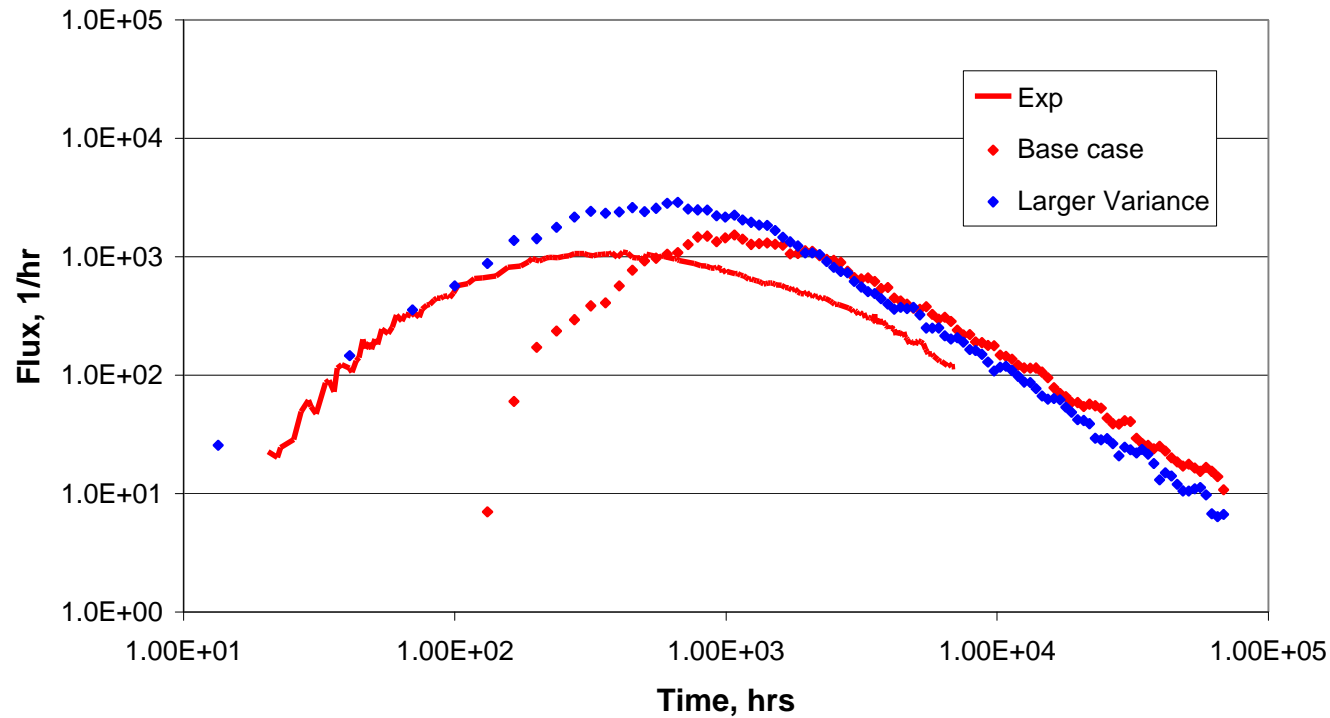




# Sensitivity Analysis, FWS



# Sensitivity Analysis Transmissivity Distribution



KTH

Chemical Engineering and Technology

# CONCLUSIONS

- **Good predictions considering that no adjustable parameters were used**
- **Strong influence of the entities governing matrix interaction and flow-rate distribution**
- **Tracer tests with non-sorbing tracer are not needed**



# SORPTION DATA

- **Determined using too large particles and too short contact times.**
- **Sorption on 1 -2 mm particles over 8.4 days.**

<b>Material / Location</b>	<b>Sorbed fraction After 8.4 days</b>
<b>Mylonite / KXTT2</b>	<b>0.021</b>
<b>Mylonite / KXTT4</b>	<b>0.120</b>
<b>Altered ÄD / KXTT2</b>	<b>0.018</b>
<b>Altered ÄD / KXTT3</b>	<b>0.051</b>
<b>Altered FGG / KXTT4</b>	<b>0.101</b>



## Appendix K

Results of modelling T6A&B  
J. Crawford (CE-KTH/SKB)

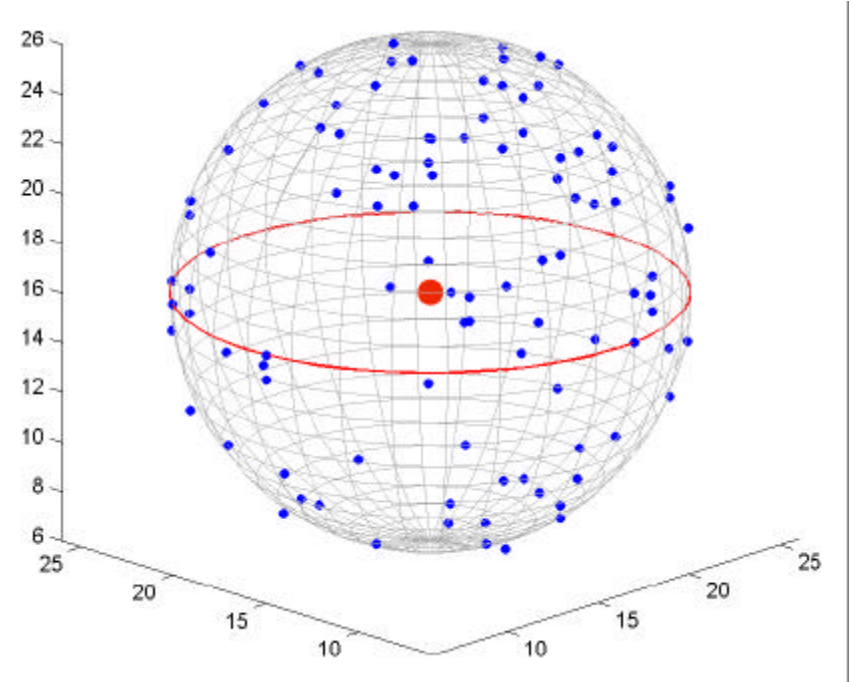
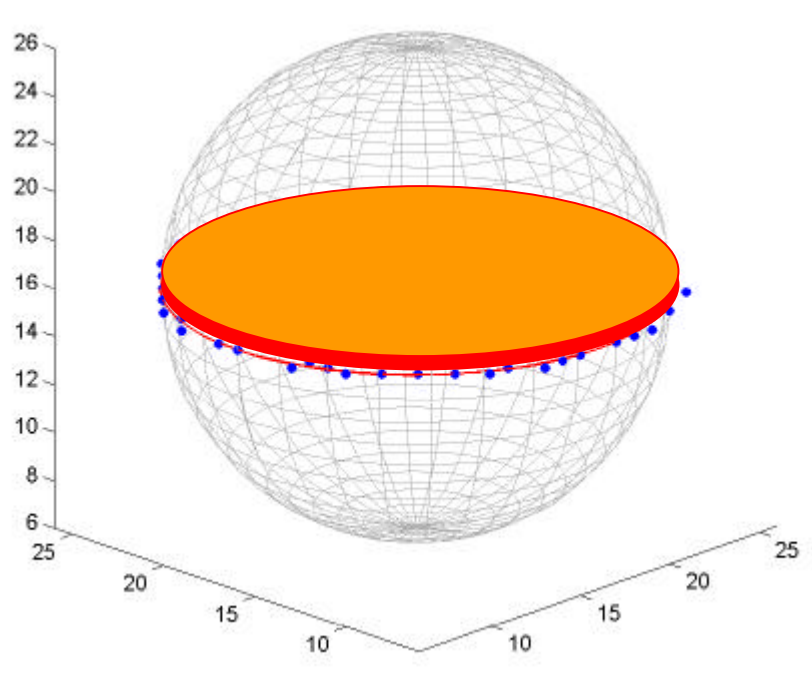
# Modelling of Task 6A and 6B - the impact of 2D and 3D flow field assumptions



**James Crawford**

**Department of Chemical Engineering and Technology  
Royal Institute of Technology  
Stockholm, SWEDEN**

# Is the STT1-b tracer test best described by a 2-D or 3-D Flow System?



## 2-D Flow Field Implications:

- ✓ “Feature A” fracture thickness may be calculated from estimated mean water residence time ( $t_w \approx 8$  h):

$$t_w = \frac{p r^2 \bar{d}}{q} \quad \Rightarrow \quad \bar{d} = 2.4 \times 10^{-3} \text{ m}$$

- ✓ Total flow-wetted surface (FWS) in “Feature A” disk:

$$FWS_{total} = 2p r^2 = 157 \text{ m}^2$$



## 3-D Flow Field Implications:

- ✓ “Feature A” fracture thickness may be calculated from estimated mean water residence time ( $t_w \approx 8$  h):

$$t_w = \frac{4pr^3 e_{flow}}{3q} = \frac{4pr^3 a_R \bar{d}}{3q} \Rightarrow \begin{aligned} \bar{d} &= 5.2 \times 10^{-5} \text{ m} \\ 4 \times 10^{-5} \text{ m} &\leq \bar{d} \leq 7 \times 10^{-5} \text{ m} \end{aligned}$$

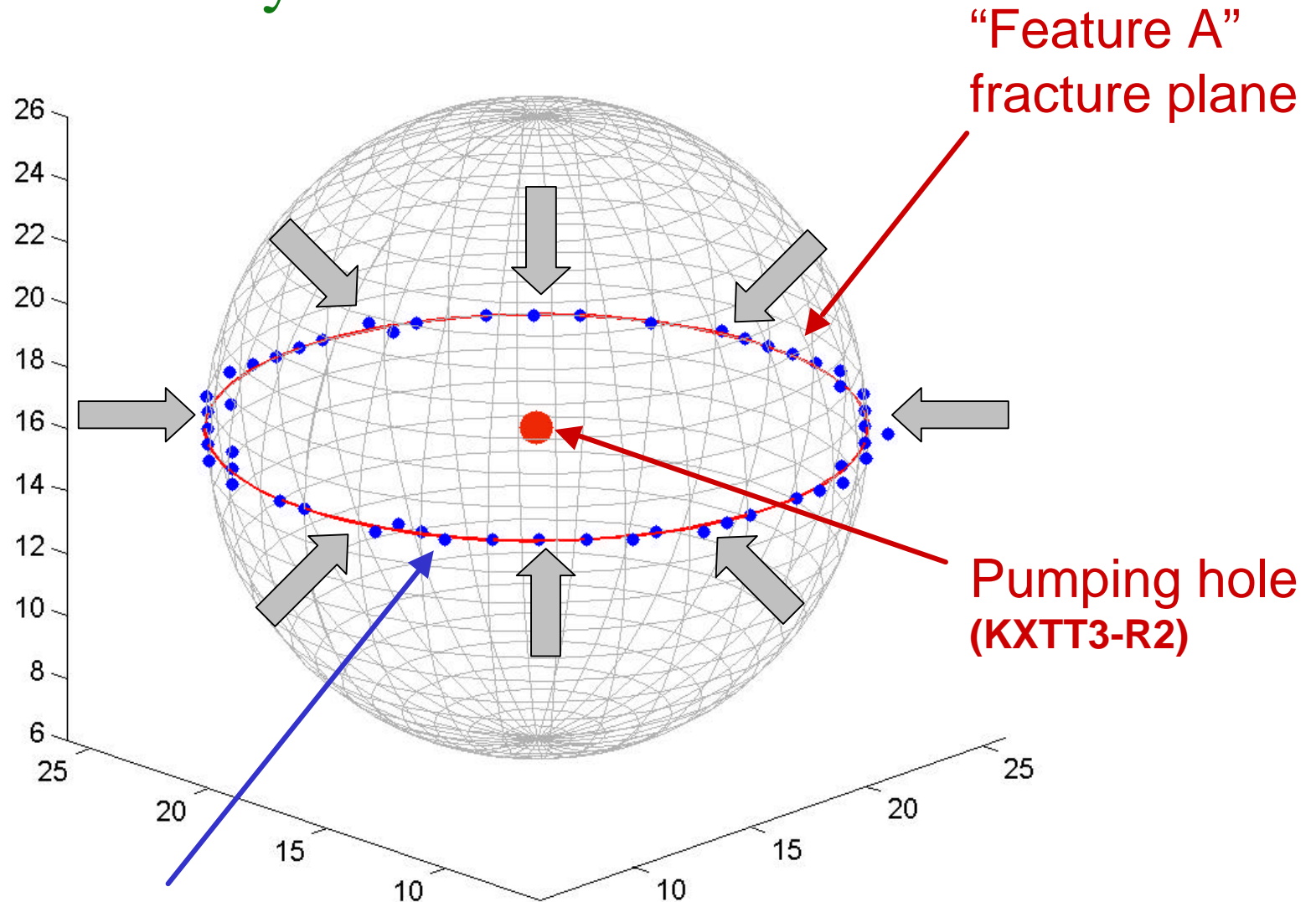
- ✓ Total flow-wetted surface (FWS) in “Feature A” sphere:

$$FWS_{total} = \frac{4pr^3 a_R}{3} \approx 3720 \text{ m}^2$$

$$3000 \text{ m}^2 \leq FWS_{total} \leq 4700 \text{ m}^2$$

**3-D sphere has 20-30 times FWS of a 2-D disk**

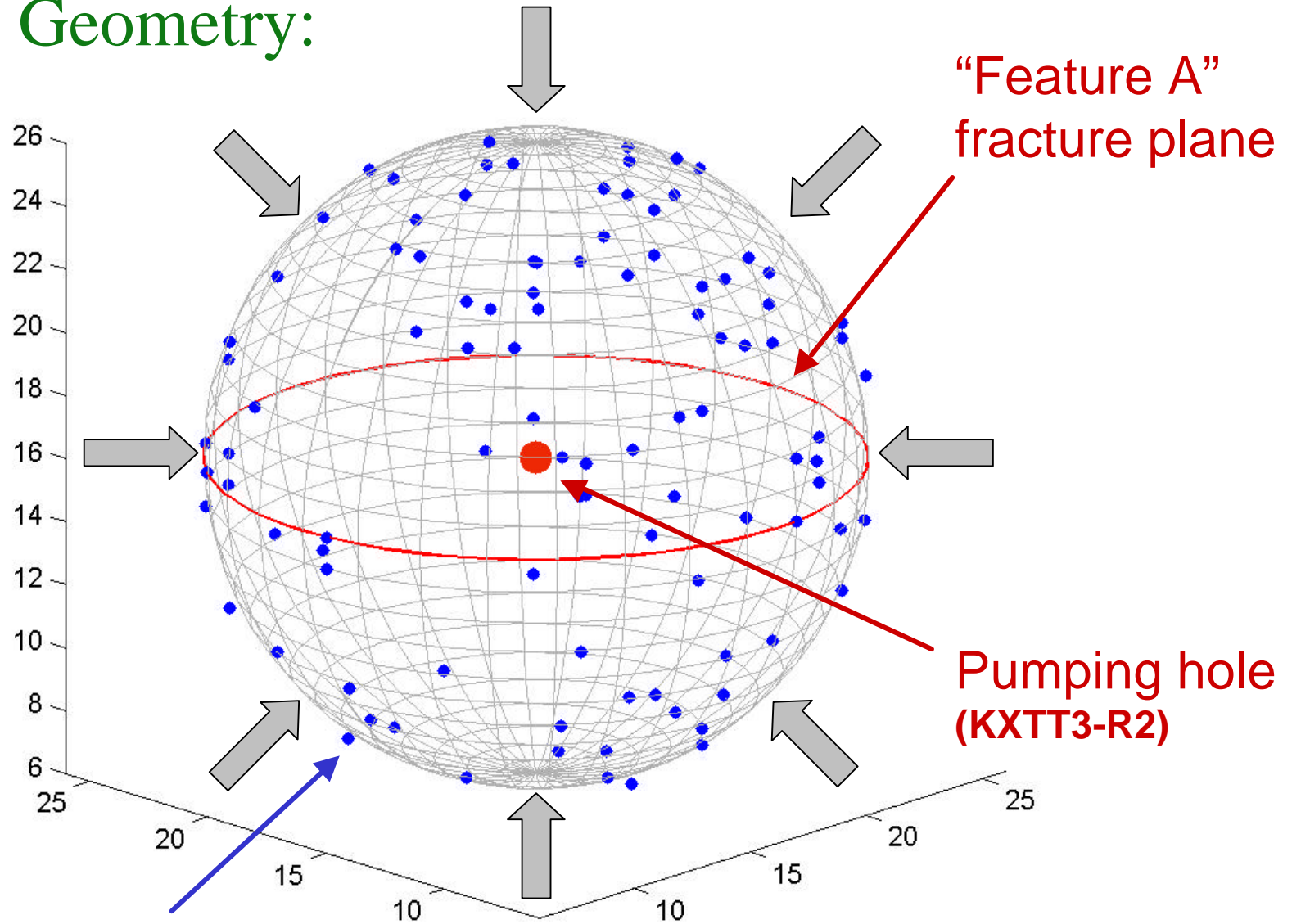
## 2-D Flow Geometry:



Simulated injection locations on  
edge of virtual circle (5m radius)

2-D Flow field  
(flow only in plane of disk)

# 3-D Flow Geometry:



Simulated injection locations on surface of virtual sphere (5m radius)

3-D Flow field (flow in entire volume)

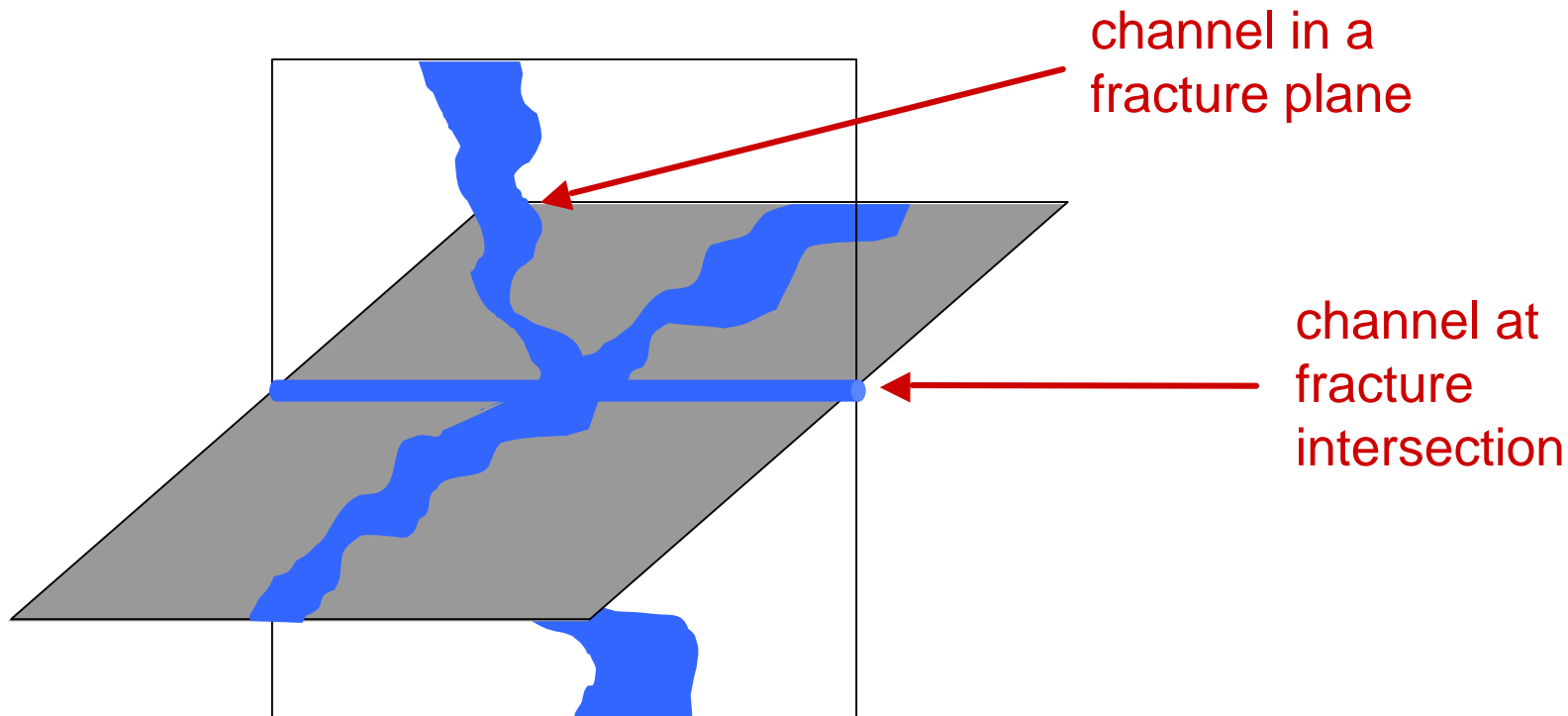
## Channel Network Model (CNM)

- ✓ Fractured rock is modelled as a 3-D network of interconnected channels
- ✓ Radionuclides in each channel have an analytic residence time distribution (RTD):

$$\frac{m}{m_{total}} = \text{Erfc} \left[ \sqrt{\frac{D_e K_d \mathbf{r}_p}{t - R_* t_w}} \right] \times \frac{FWS}{q}$$

- ✓ Dispersion in the system is dominated by the difference in advective travel times in different channels (diffusion/dispersion in individual channels can be neglected)

## CNM Model Concept:



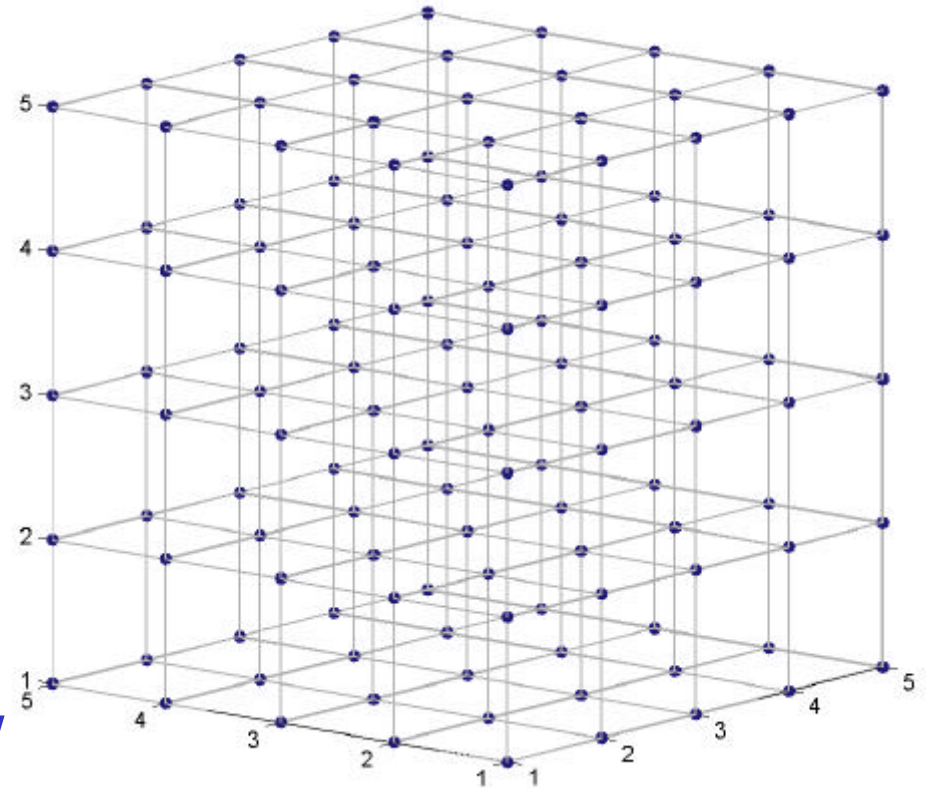
Each node is connected to 6 other nodes

Perfect mixing at each node (an assumption)

Channel conductivity is randomly assigned from a log-normal distribution ( $\log_{10} C = \mu_c \pm \sigma_c$ )

## CHAN3D - flow

- ✓ Network of  $n \times n \times n$  connected nodes
- ✓ Sparse matrix system ( $n^3 \times n^3$ )
- ✓ Constant head and constant flow boundary conditions
- ✓ Flow = conductance  $\times$  hydraulic head difference
- ✓ Iterative numerical solution  $\Rightarrow$  steady state flow  
(biconjugate gradient method with incomplete LU-decomposition)



## CHAN3D - transport

- ✓ Particle tracking technique (ca. 10 000 particles)
- ✓ Particle transit time from injection point to pumping hole is sum of residence times in each channel
- ✓ At nodes the particles “choose” exit flow channels stochastically - probability is proportional to flowrate in each of the 6 neighbouring channels
- ✓ Monte Carlo type simulation - particle tracking performed for many different CHAN3D-flow realisations

## Flow simulations for TASK 6A & 6B

- ✓ Pumping flowrate: 210.24 m<sup>3</sup>/year (6A)  
0.21024 m<sup>3</sup>/year (6B)
- ✓ Conductance:  $\log_{10}C = -0.48 \pm 0.94$  (estimated from borehole data)
- ✓ Cubic volume simulated (31 × 31 × 31 nodes)
- ✓ 2-D and 3-D flow field simulated separately  
(100 realisations each)
- ✓ Flow porosity ( $e_{flow}$ ) adjusted to fit non-sorbing tracer arrival time
- ✓ Channel length 0.5m (i.e., 2 fractures/m, estimated from borehole data)
- ✓ Cubic law for fracture aperture-flow relation ( $q \propto \delta^3$ )



# Transport simulations for TASK 6A & 6B

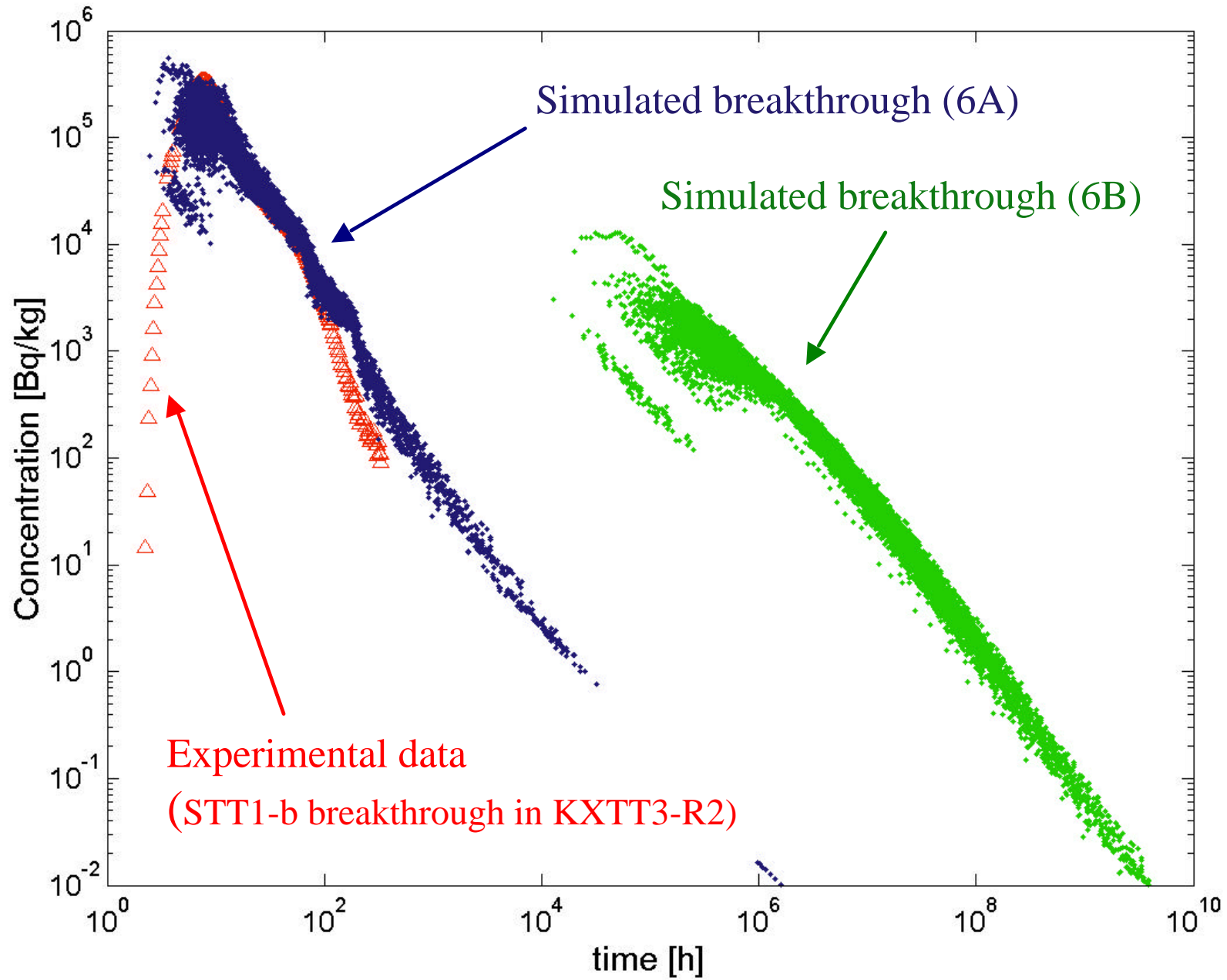
Diffusion & sorption parameters taken from task specification

$$\frac{m}{m_{total}} = \text{Erfc} \left[ \sqrt{\frac{D_e K_d r_p}{t - R_* t_w}} \right] \times \frac{FWS}{q} \left\{ \begin{array}{l} D_e K_d r_p = D_e (e_p + (1 - e_p) K_d r_s) \\ R_* = 1 + \frac{2K_a}{d} \end{array} \right.$$

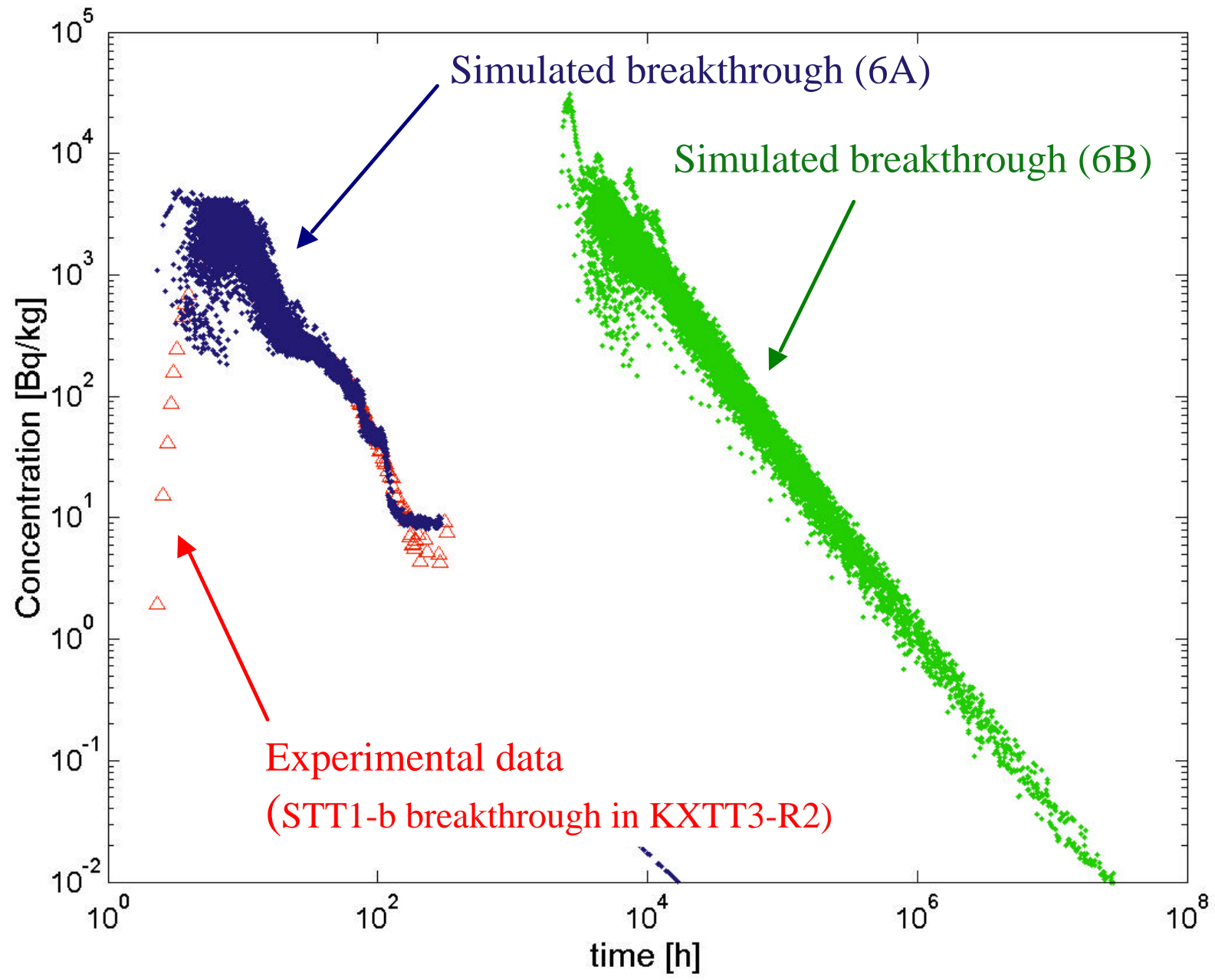
$e_p = 0.001$  (assumed)

	Hto	I <sub>131</sub>	Sr <sub>85</sub>	Tc <sub>99</sub>	Co <sub>58</sub>	Am <sub>241</sub>
$D_e K_d r_p$	$9.64 \times 10^{-7}$	$2.62 \times 10^{-9}$	$4.31 \times 10^{-6}$	$6.80 \times 10^{-4}$	$1.97 \times 10^{-6}$	$1.70 \times 10^{-3}$
$K_a$	0.0	0.0	$8 \times 10^{-6}$	0.2	0.008	0.5
$m_{total}$ [Bq]	$7.59 \times 10^7$	$7.9 \times 10^5$	$3.3 \times 10^5$	$1.7 \times 10^6$	$3.5 \times 10^6$	$3.5 \times 10^6$

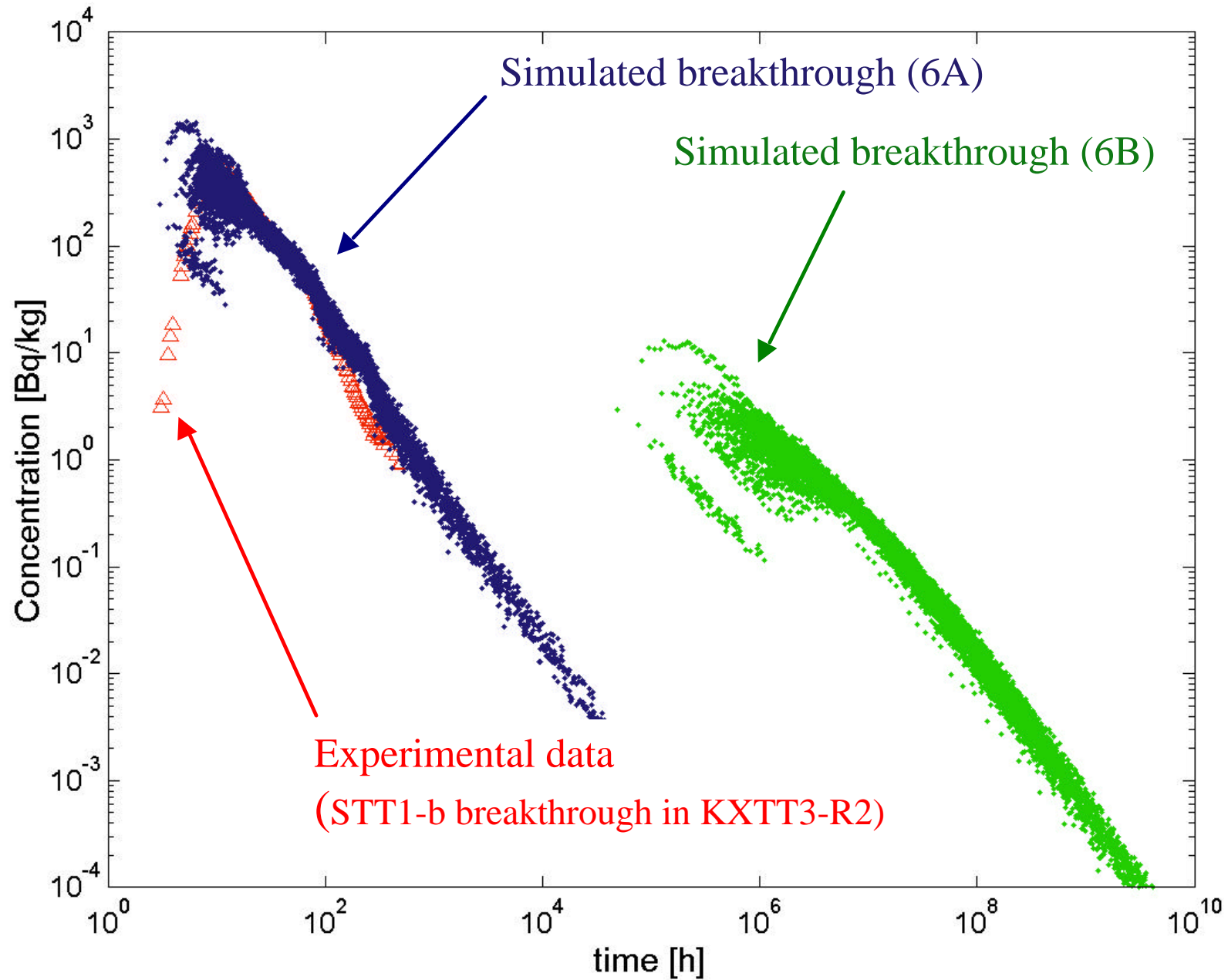
# Tritiated water (Hto) - 3D flow field



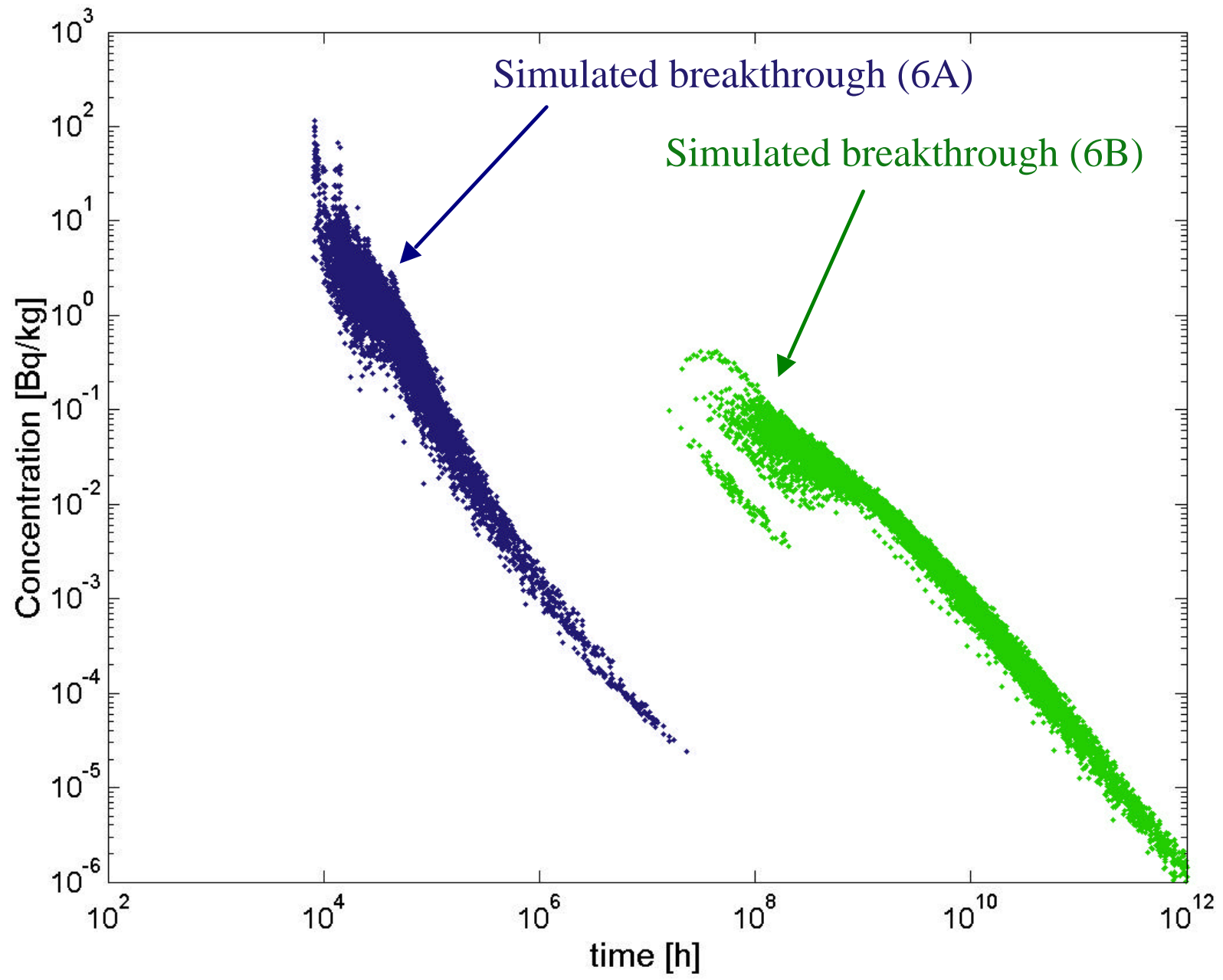
# $I_{131}$ - 3D flow field



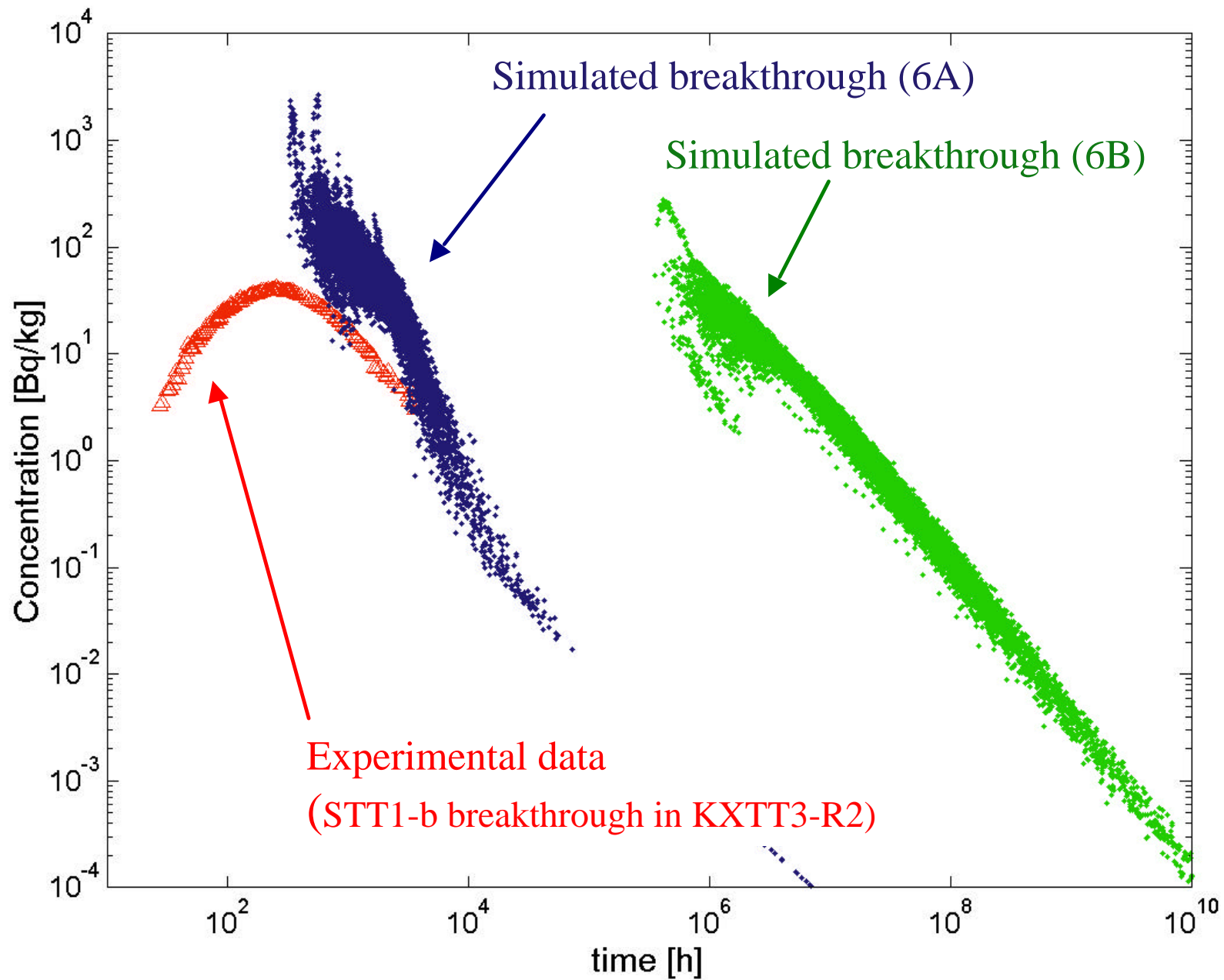
# Sr<sub>85</sub> - 3D flow field



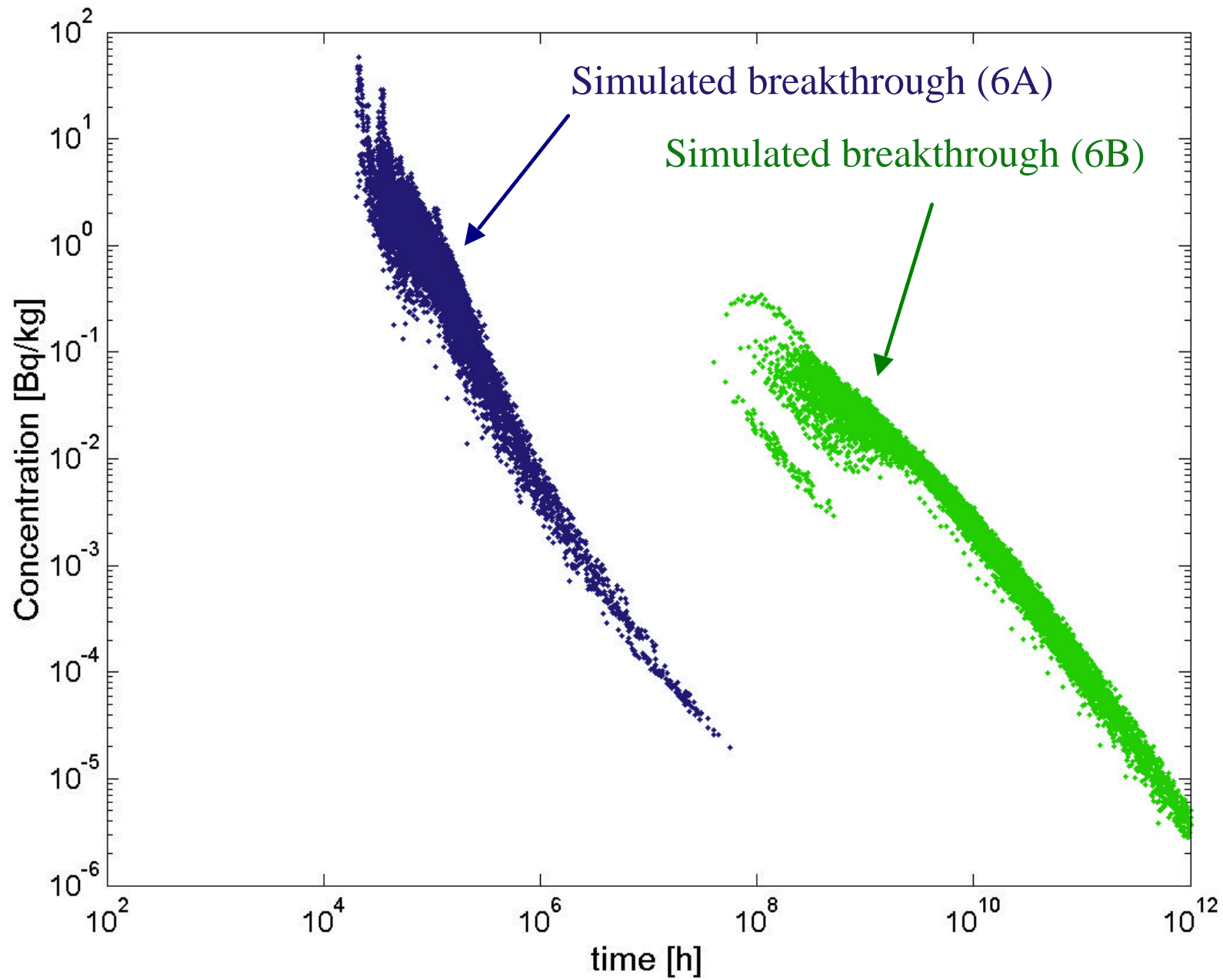
# Tc<sub>99</sub> - 3D flow field



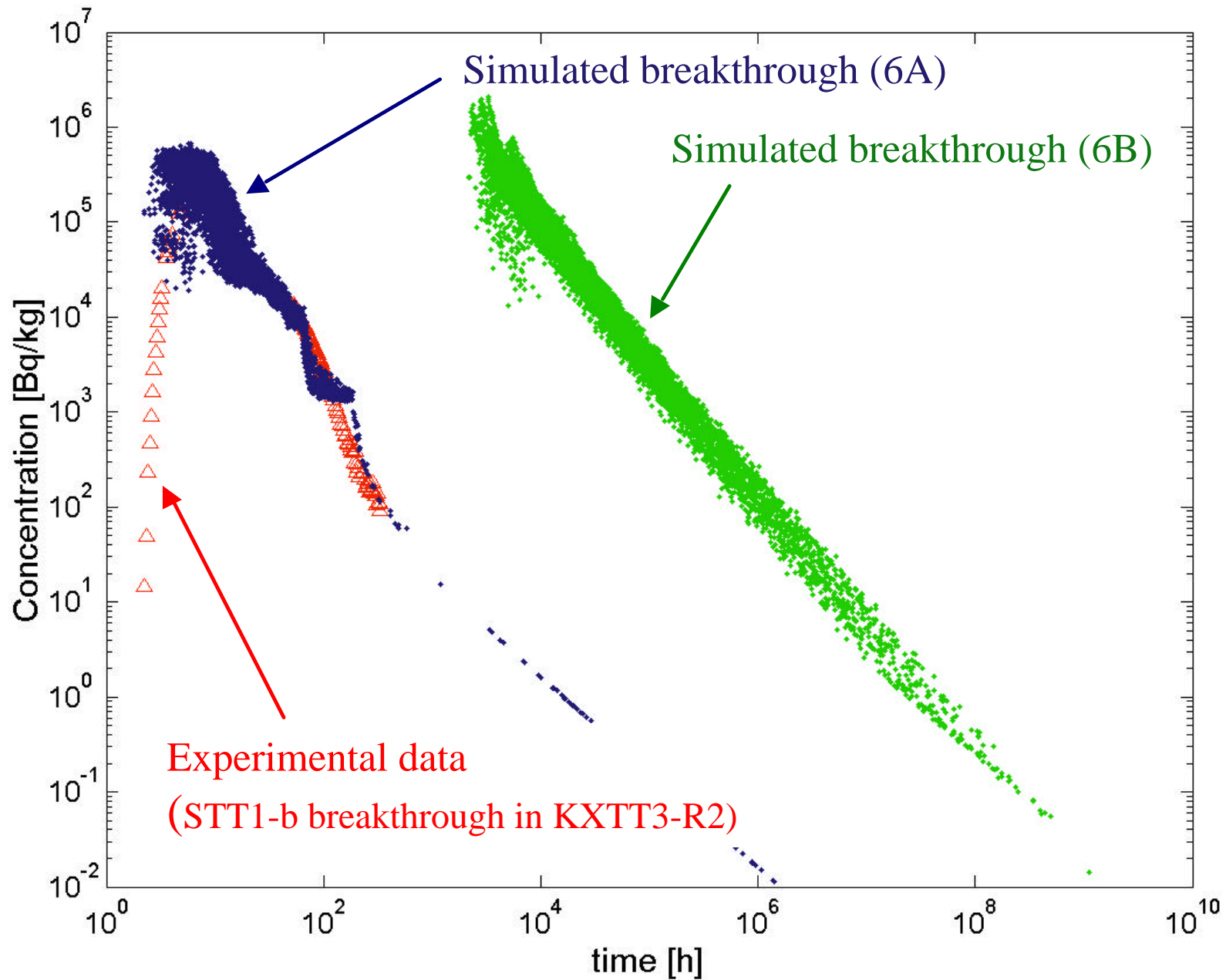
# Co<sub>58</sub> - 3D flow field



# Am<sub>241</sub> - 3D flow field

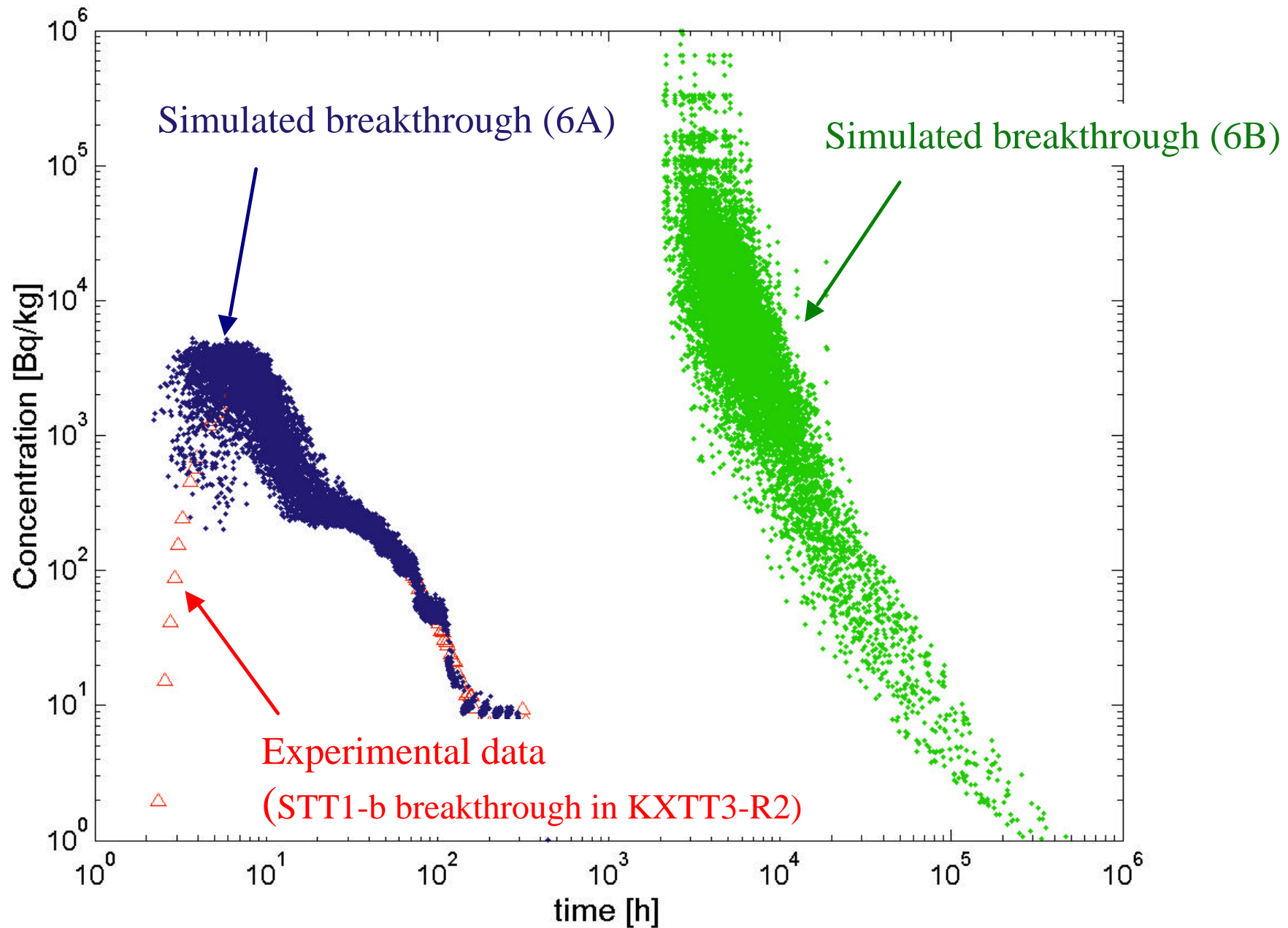


# Tritiated water (Hto) - 2D flow field

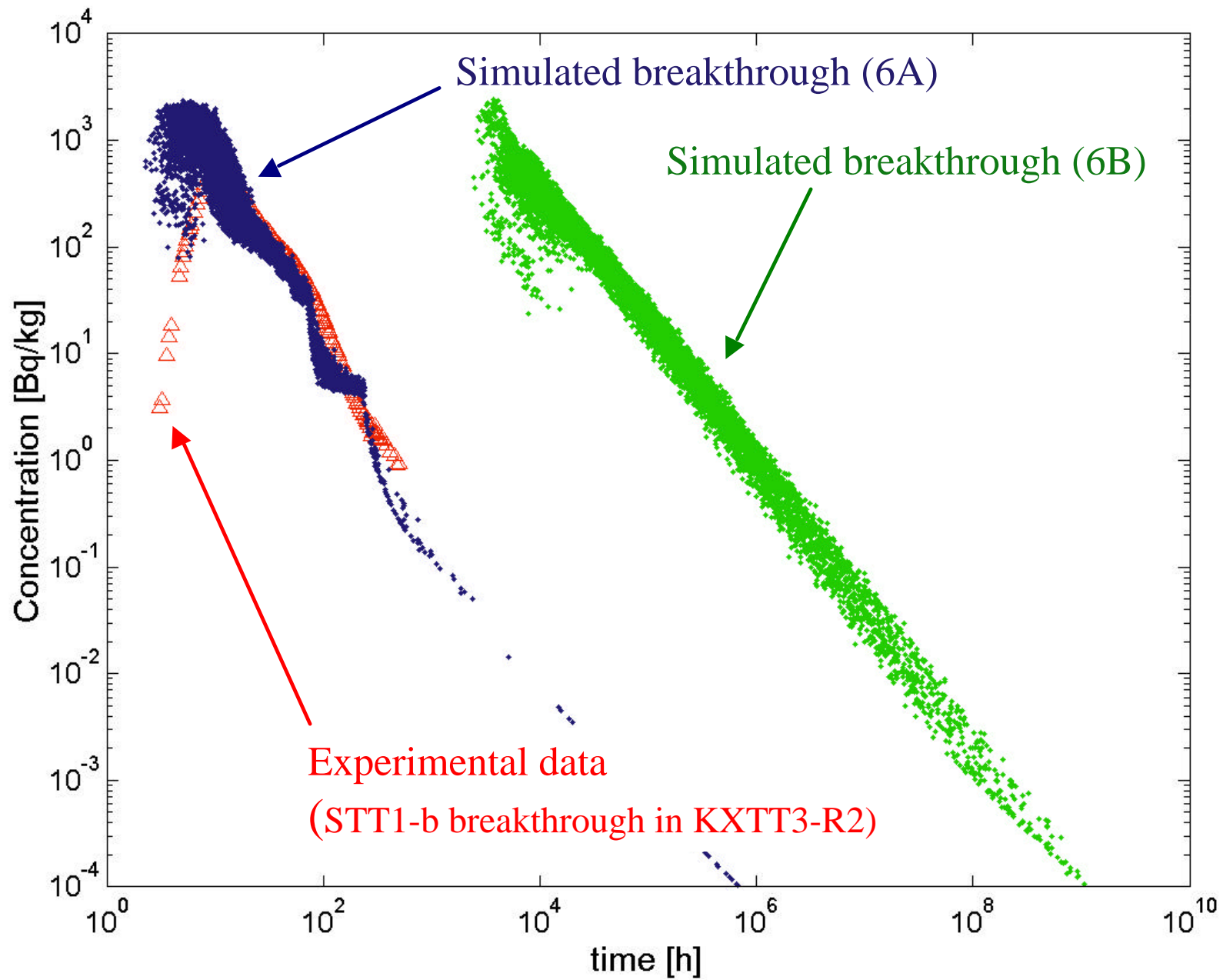




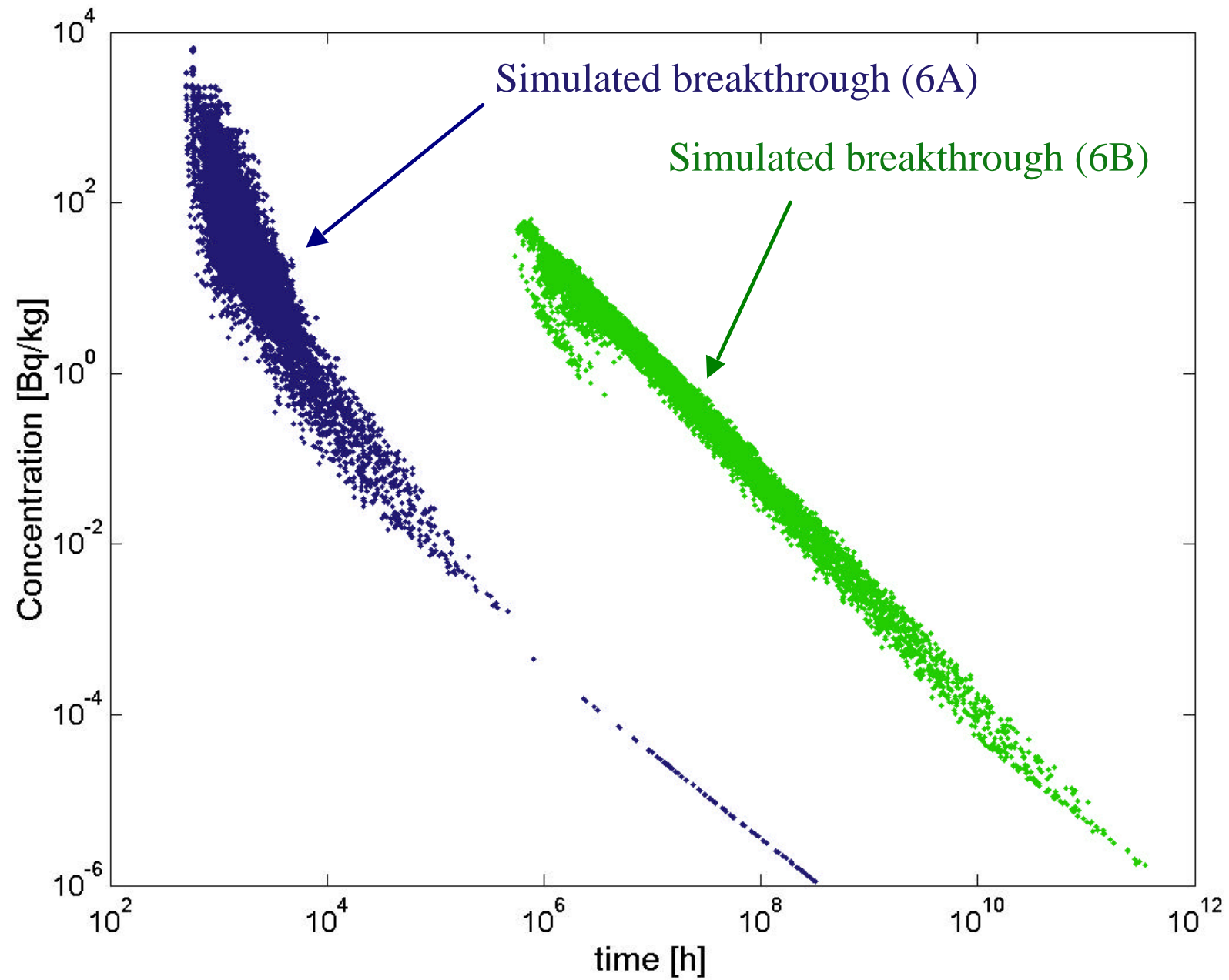
# $I_{131}$ - 2D flow field



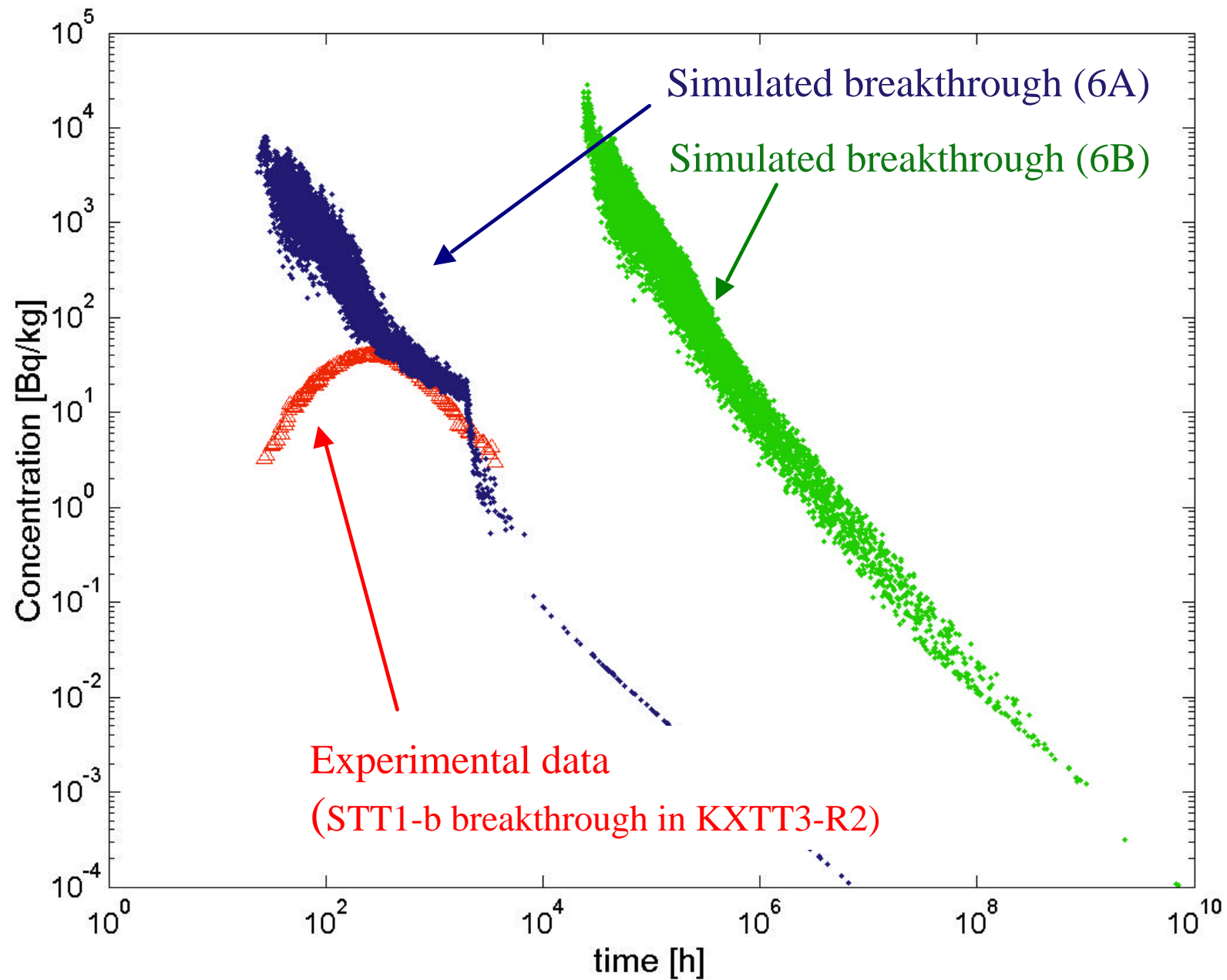
# Sr<sub>85</sub> - 2D flow field



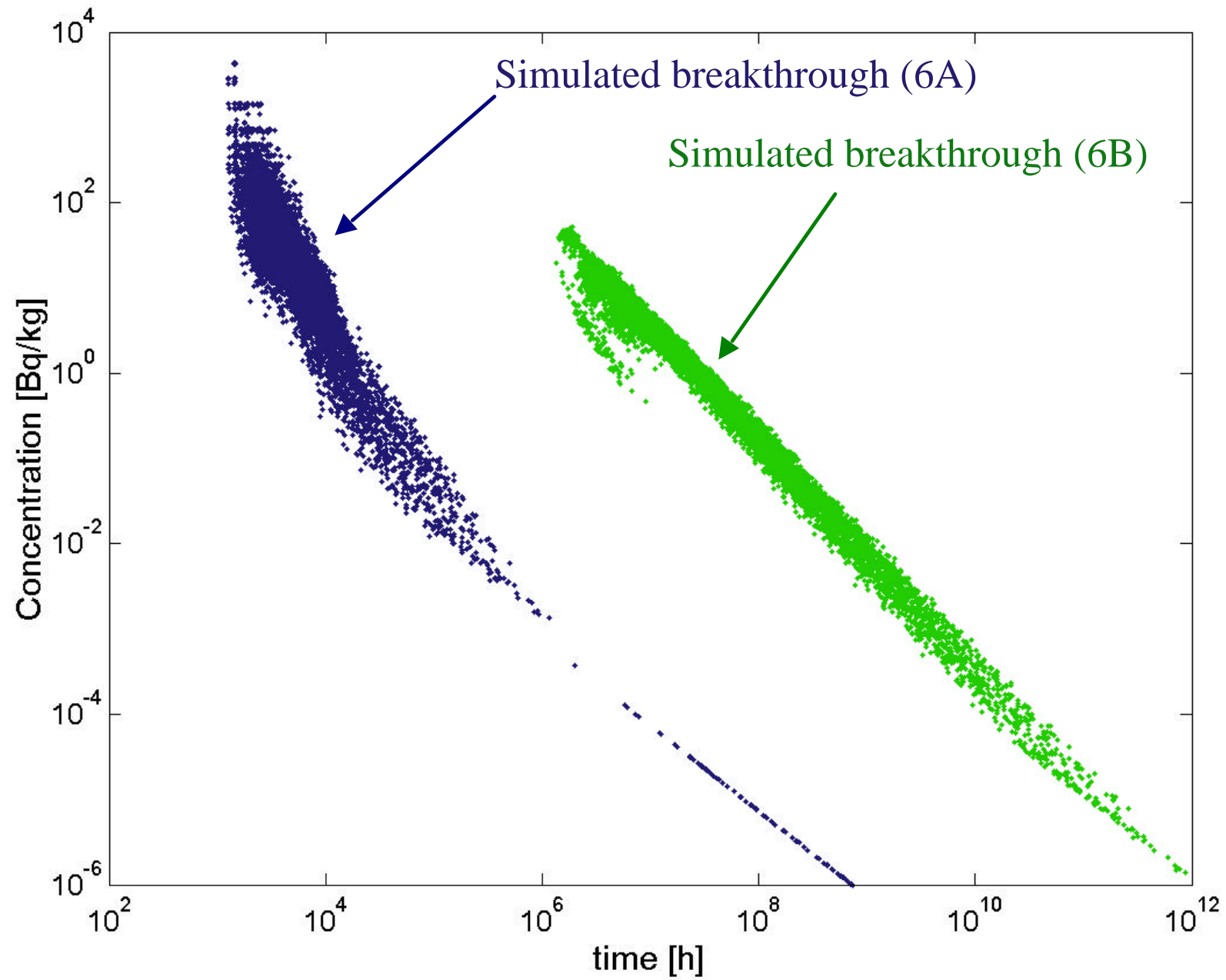
# Tc<sub>99</sub> - 2D flow field



# Co<sub>58</sub> - 2D flow field



# Am<sub>241</sub> - 2D flow field



# 3-D Transport Simulation Results

	$I_{131}$	Hto	$Co_{58}$	$Sr_{85}$	$Tc_{99}$	$Am_{241}$
$D_e K_d \mathbf{r}_p$	$2.62 \times 10^{-9}$	$9.64 \times 10^{-7}$	$1.97 \times 10^{-6}$	$4.31 \times 10^{-6}$	$6.80 \times 10^{-4}$	$1.70 \times 10^{-3}$
$t_{50}$ (STT1-b)	13	11	750	24	n/a	n/a
$t_{50}$ (6A)	15	21	1510	43	4 (y)	10 (y)
$t_{50}$ (6B)	2 (y)	374 (y)	940 (y)	1700 (y)	270 000 (y)	670 000 (y)
$\frac{t_{50} (6B)}{t_{50} (6A)}$	$1.1 \times 10^3$	$1.6 \times 10^5$	$5.4 \times 10^3$	$3.4 \times 10^5$	$6.7 \times 10^4$	$6.7 \times 10^4$

⇒ average drawdown in KXTT3-R2 is **-88 m**

## 2-D Transport Simulation Results

	$I_{131}$	Hto	$Co_{58}$	$Sr_{85}$	$Tc_{99}$	$Am_{241}$
$D_e K_d \mathbf{r}_p$	$2.62 \times 10^{-9}$	$9.64 \times 10^{-7}$	$1.97 \times 10^{-6}$	$4.31 \times 10^{-6}$	$6.80 \times 10^{-4}$	$1.70 \times 10^{-3}$
$t_{50}$ (STT1-b)	13	11	750	24	n/a	n/a
$t_{50}$ (6A)	12	9	120	11	0.2 (y)	0.5 (y)
$t_{50}$ (6B)	0.6 (y)	1.7 (y)	11 (y)	5.4 (y)	950 (y)	2 400 (y)
$\frac{t_{50} (6B)}{t_{50} (6A)}$	450	$1.7 \times 10^3$	800	$4.5 \times 10^3$	$5.4 \times 10^3$	$5 \times 10^3$

⇒ average drawdown in KXTT3-R2 is **-71 m**

# Result Summary

## TASK 6A

$I_{131}$	$12 < t_{50} < 15$
Hto	$9 < t_{50} < 21$
$Co_{58}$	$120 < t_{50} < 1510$
$Sr_{85}$	$11 < t_{50} < 43$
$Tc_{99}$	$0.2 < t_{50} \text{ (y)} < 4$
$Am_{241}$	$0.5 < t_{50} \text{ (y)} < 10$

## TASK 6B

$0.6 < t_{50} \text{ (y)} < 2$
$1.7 < t_{50} \text{ (y)} < 374$
$11 < t_{50} \text{ (y)} < 940$
$5.4 < t_{50} \text{ (y)} < 1700$
$950 < t_{50} \text{ (y)} < 270\ 000$
$2\ 400 < t_{50} \text{ (y)} < 670\ 000$



## Observations:

- ✓ Experimental breakthrough times are “windowed” by the predicted breakthrough times given by the 2-D and 3-D flow simulations, respectively
- ✓ For strongly sorbing tracers, the travel time is governed by the **FWS/q** ratio and is independent of water residence time (flow porosity and fracture thickness not required)

For a single fracture:

$$t_{50} \approx K_a \left| \frac{FWS}{q} \right| + \frac{D_e K_d \mathbf{r}_p}{2 \times \text{Erf}^{-1}[0.5]} \left| \frac{FWS}{q} \right|^2$$

## Conclusions:

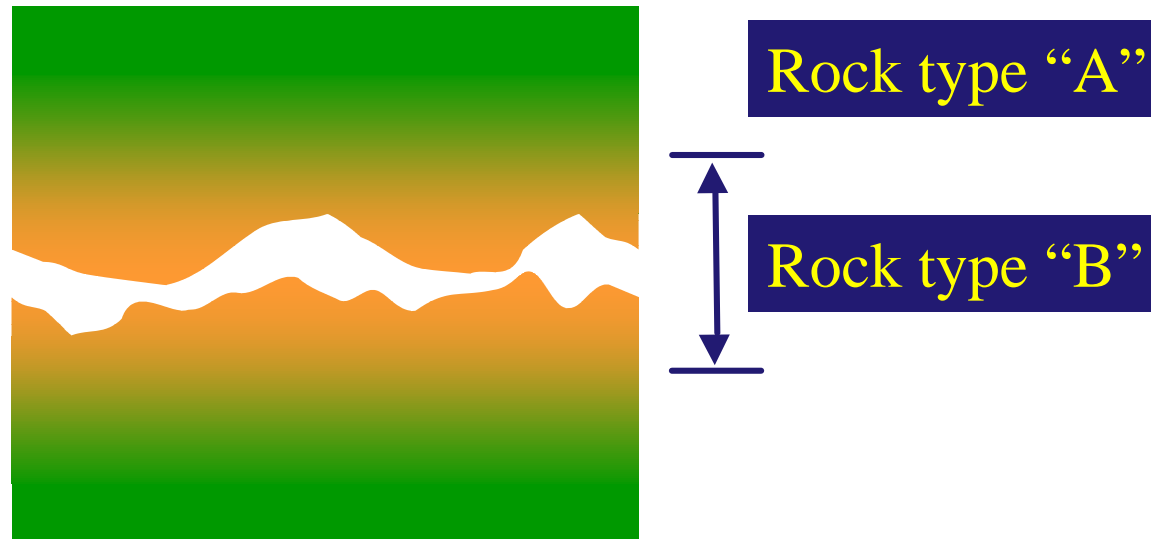
- ✓ Neither 2-D nor 3-D flow simulations give results that are entirely consistent with the experimental breakthrough data.

**A highly conductive “Feature A” combined with a less conductive 3-D flow structure is a distinct possibility that has not been explored in this preliminary study**

- ✓ The transport of strongly sorbing tracers can be modelled using data obtained independently ( $\mu_c, \sigma_c, K_a, K_d, D_e, e_p$ ) **without calibration** of hydraulic parameters

## Simulation on Longer Time-Scales (i.e. low flowrates)

- ✓ The diffusion/sorption properties of individual tracers should be considered when assigning average rock matrix parameters (these may differ when going from high- to low flowrate conditions)



## High Flowrates?

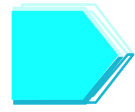
- ✓ The  $K_d$ ,  $D_e$ , and  $\varepsilon_p$  values should reflect the rock properties near the surface of the fracture for both sorbing- and non-sorbing tracers

## Low Flowrates?

- ✓ For very strongly sorbing tracers, the  $K_d$ ,  $D_e$ , and  $\varepsilon_p$  values should reflect the rock properties near the surface of the fracture
- ✓ For weakly- or non-sorbing tracers, the  $K_d$ ,  $D_e$ , and  $\varepsilon_p$  values should reflect the rock properties in the main rock volume

## Appendix L

Pathway and microstructure channel network model for  
5m scale radionuclide transport  
W. Dershowitz (Golder/JNC)



# Pathway and Microstructure Channel Network Model for 5 meter scale Radionuclide Transport

Äspö Task 6

Integrated Performance Assessment and Site  
Characterization Modeling

11 September, 2001

Masahiro Uchida/JNC

Bill Dershowitz/Golder

Dawn Shuttle/Golder

# Presentation

- Purpose and objectives of Task 6
- Summary of first modeling task
- The JNC/Golder approach
- Results of analyses
- Importance for PA models
- Conclusions

## Overview

- **Task 6 combines the use of Performance Assessment (PA) and Site Characterization (SC) models, using both PA and SC type boundary conditions.**
- **There is no formal difference between PA and SC models, however typically SC models are more complex than the models used for PA.**
- **Focusing on the 50-100m scale, both PA and SC models will be used to predict releases.**



## Objectives of Task 6

- Assess simplifications used in PA models.
- Assess the constraining power of tracer (and flow) experiments for PA models
- Provide input for site characterization programs from a PA perspective (i.e., provide support for site characterization program design and execution aimed at delivering needed data for PA).
- Understand the site-specific flow and transport behavior at different scales using SC models

## Objective 1 may be elaborated to:

- Identify key assumptions needed for long term prediction in PA and identify less important assumptions in PA
- Identify the most significant PA model components of a site.
- Prioritize assumptions in PA modeling and demonstrate a rationale for simplifications in PA-models by parallel application of several PA models of varying degree of simplification.

## Objective 1 may be elaborated to: (cont)

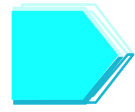
- Provide a benchmark for comparison of PA and SC models in terms of PA measures for radionuclide transport at PA temporal and spatial scales
- Establish how to transfer SC models using site characterization data to PA models, i.e., how to simplify SC models into PA models in a consistent manner

# Initial Simulations

- TRUE-1 site at the 5m scale
- Selected tracer tests modeled to provide model constraints
- PA time scales. Any assumptions may be made provided the material properties from the SC tracer models are honored.

## JNC/Golder Approach for Task 6A

- Determine the extent to which STT-1b Tracer breakthrough constrain the tracer pathway properties
- Stochastic/ Sensitivity Analysis with the GoldSim PA Code
- Start with single pipe of length 5m with uniform properties
- Sensitivity Study: Advection, dispersion, diffusion, and sorption for advective and immobile porosities



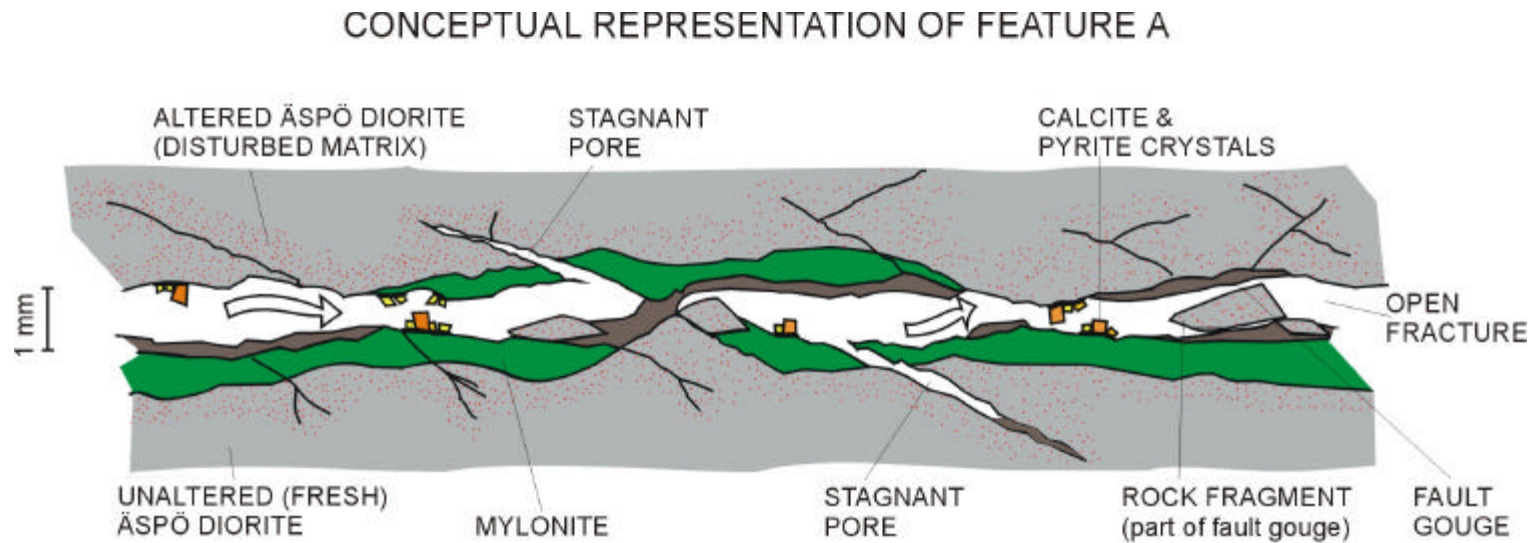
# Transport Properties Constrained by STT-1b Tracer Breakthrough

- Measures for “Goodness of Fit” to STT-1b
  - T05
  - T50
  - T95
  - Time for peak release
  - Peak release rate
- The error term used to rank the simulations was the sum of the squares of the percentage error in the value. This results in the best fits being those with reasonable fits to all “goodness of fit” measures.

## Limitations of Approach

- **The stochastic approach has the advantage of testing multiple parameter combinations. However, as there were many degrees of freedom the unprocessed fits are generally not as good as can be obtained with inversion methods**

# Conceptual Model



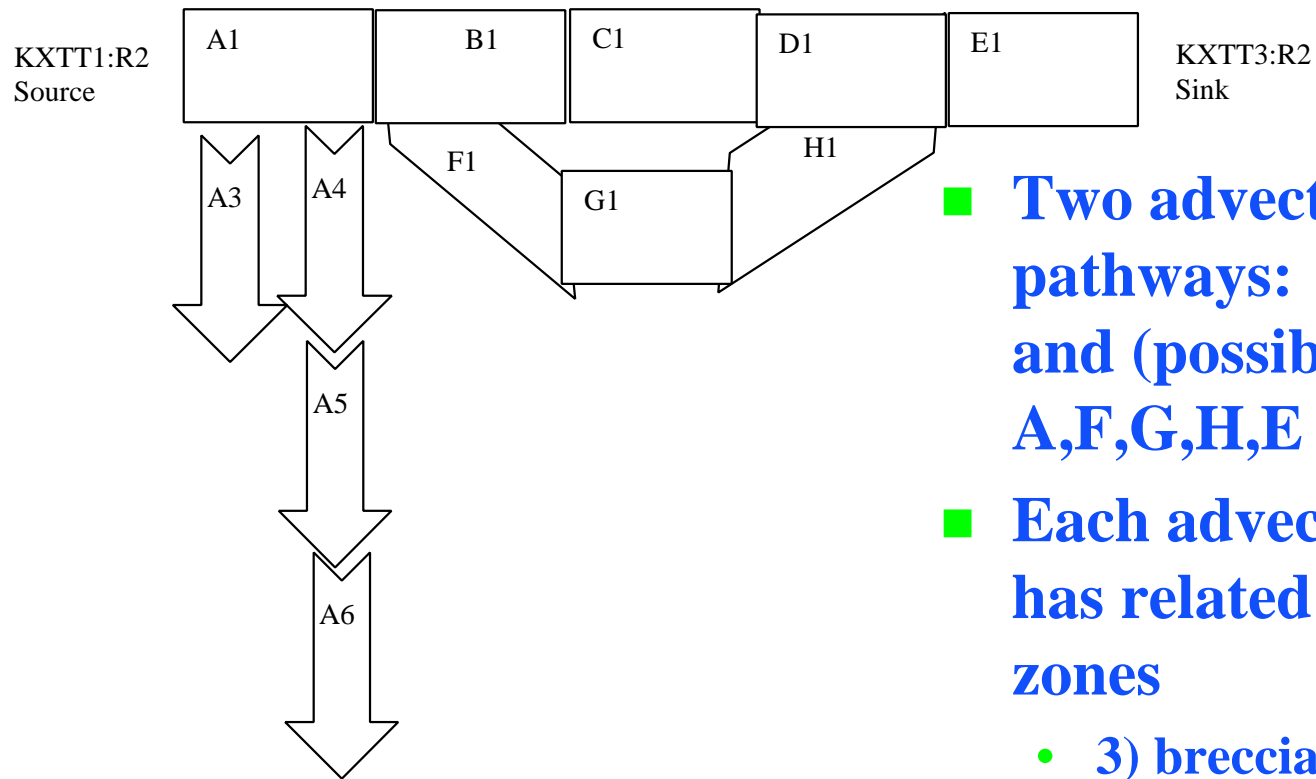
FRACTURE APERTURE TO SCALE. OTHER GEOLOGICAL UNITS NOT TO SCALE

Figure 2-1. Schematic conceptual representation of Feature A in cross section (not to scale).

From Selroos and Elert



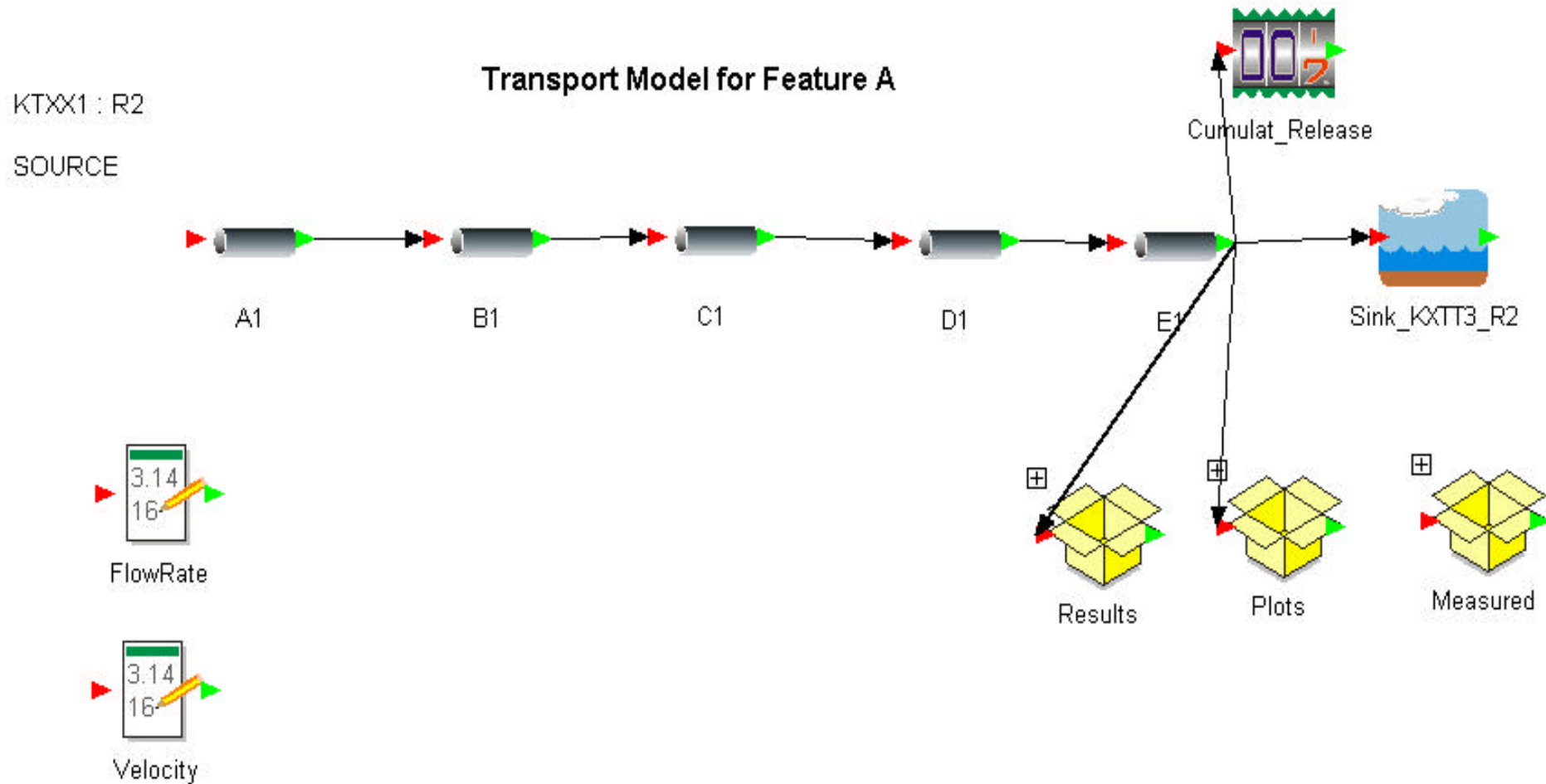
# Implementation of Conceptual Model

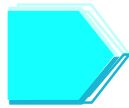


- **Two advective pathways: A,B,C,D,E and (possibly) A,F,G,H,E**
- **Each advective pathway has related immobile zones**
  - 3) breccia/infilling
  - 4) coating/mylonite
  - 5) altered wall rock
  - 6) unaltered rock mass

Note: initial simulations only use single A-E pathway

# GoldSim Implementation of Microstructure/Pathway Model



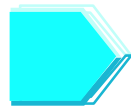


# GoldSim Rock Types

The screenshot shows the GoldSim software interface. On the left is a hierarchical tree view of the model, including components like HTO, I131, MassRelease, Results, and Rock\_Types. The main window displays a grid of elements for different rock types: Breccia, Mylonite, and RockMass. Each rock type has associated elements for Dmax, Tortuosity, and Porosity. The 'Tortuosity\_Mylonite' element is selected, and a text box at the bottom contains the following user-added notes:

Assumed relative to unaltered rock mass.  
Based on back calculation from provided effective Diffusions.  
see Task6 properties.xls for details  
Reference: Task 6A & 6B Modeling Task Specification, pp11 & 19

User added notes for the selected element  
(Tortuosity\_Mylonite)



# GoldSim Matrix Zone Properties

**Pipe Pathway Properties : C1**

Definition | Inflows | Outflows

Element ID:  Appearance...

Description:

Basic Pipe Properties

Length:

Area:

Perimeter:

Dispersivity:

Infill Medium:



C1

**Define Matrix Diffusion Zones**

Source Zone

Skin Medium:  Skin Thickness:

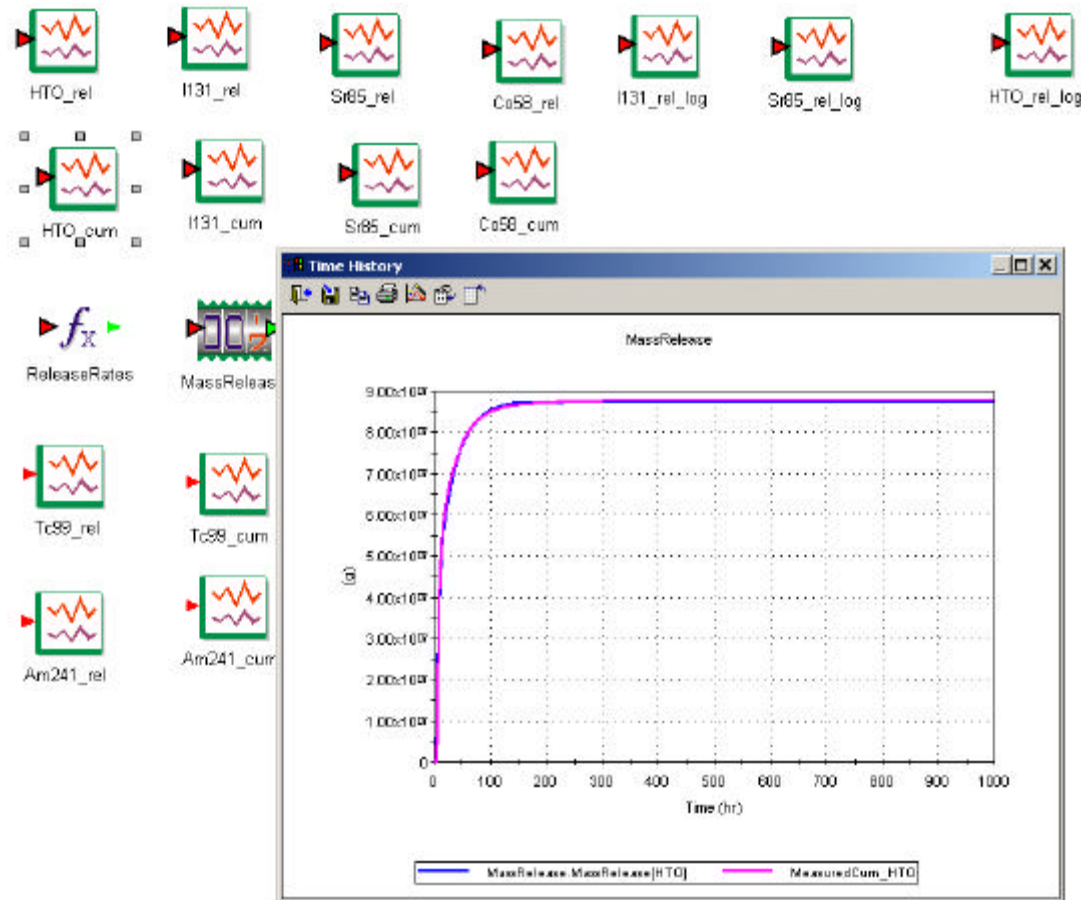
Advanced Pipe

Used	Medium	Geometry	Minimum Thickness	Maximum Thickness	Fraction of Perimeter	Effective Area (m2)
<input checked="" type="checkbox"/>	Microcracks	Slab	<input type="text" value="Dmax_RockMass"/>	<input type="text" value="Dmax_RockMass"/>	<input type="text" value="1.0"/>	0.011 m2
<input type="checkbox"/>		Slab	<input type="text" value="0.0 m"/>	<input type="text" value="0.0 m"/>	<input type="text" value="1.0"/>	
<input type="checkbox"/>		Slab	<input type="text" value="0.0 m"/>	<input type="text" value="0.0 m"/>	<input type="text" value="1.0"/>	

Save Masses as  
M:   
Cc:

OK Cancel Help

# GoldSim Graphical Output



# Definitions

## ■ Transfer Rate

- In summary the transfer rate is related to the rate of mass transfer between the stagnant and flowing portions of the advective pathway
- Analogous to dispersion, but does not allow upstream mixing

# Definitions

## ■ Transfer Rate

- GoldSim allows the user to explicitly represent a single stagnant dispersive zone in a one-dimensional pathway. The user must specify the fraction of the pathway that is stagnant. As noted by its name this portion of the pathway is assumed to have negligible advective velocity. It can be filled with a porous medium (to which species can sorb). Transfer between the stagnant and the mobile zone is advective, and thus varies proportionally to the quantity of fluid flowing through the pathway. The constant of proportionality (the transfer rate) has dimensions of 1/length. It is defined as the probability of an individual solute molecule moving from the mobile zone to the stagnant zone per length of distance traveled in the mobile zone.

# Definitions

## ■ Porosity of AE

- The porosity of the main pathway comprising A-E.
- GoldSim allows the flowing pathway to contain rock onto which the tracers are able to sorb.

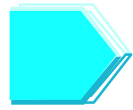


# Single Pathway Parameters

Parameter	Units	Distribution	Minimum	Maximum
Width	mm	Discrete	100	100
Aperture	mm	LogUniform	0.01	0.1
Travel Time	hour	Uniform	0.5	1.5
Dispersion Length	m	Discrete	0.05	1
Stagnant Proportion	-	-	0.8	0.8
Transfer Rate	1/m	-	0.1	0.1
Porosity AE	-	-	1.0	1.0
Porosity Pools	-	PorosityAE		

Note: transfer rate, stagnant proportion and porosity of the flowing zone and pools were set constant for initial simulations

Width scales with flow rate, therefore width set as constant if only one available pathway



# Single Pathway Parameters

## *Probabilistic and Sensitivity Studies*

Rock	Parameter	Units	Distribution	Minimum	Maximum
Breccia/ Infillings	Dmax	mm	Uniform	0	4
	Porosity	-	Uniform	0.01	0.4
	Tortuosity	-	Discrete	0.0125	0.0125
Mylonite/ Altered Wall Rock	Dmax	mm	Uniform	0	20
	Porosity	-	Uniform	0.005	0.2
	Tortuosity	-	Discrete	0.0125	0.0125
RockMass	Dmax	mm	Uniform	10	100
	Porosity	-	Uniform	0.001	0.005
	Tortuosity	-	Discrete	0.0125	0.0125

Note: Tortuosity was back-calculated from the Deff values given in “conceptual transport model for feature A”

# Effective Diffusivities

- **Based on Task 6A & 6B Modeling Task Specification**
- **$D_{\text{eff}} = D_0 * \text{porosity} * \text{tortuosity}$**
- **$D_0 = D_0 \text{ for water} * \text{relative diffusivity}$** 
  - **$D_0 \text{ for water} = 1.e-9 \text{ m}^2/\text{s}$**
  - **$D_{\text{rel\_HTO}} = 2.4$**
  - **$D_{\text{rel\_I}} = 1.66$**
  - **$D_{\text{rel\_Sr}} = 0.79$**
  - **$D_{\text{rel\_Co}} = 0.58$**

# Reference for Kd values

## ■ HTO

- conservative tracer

## ■ I-131

- conservative tracer values gave good fit
- range 0.0 - 0.001 m<sup>3</sup>/kg from Task 6A & 6B Modelling Task Specification, page 11

# Reference for Kd values (values outside this range tested for Sr & Co)

## ■ Sr-85

- $4.7 \times 10^{-6}$  m<sup>3</sup>/kg from Task 6A & 6B Modeling Task Specification, page 20

## ■ Co-58

- references from Task 6A & 6B Modeling Task Specification
- $8.0 \times 10^{-4}$  m<sup>3</sup>/kg from Table 3-2
- 0.024 - 0.049 m<sup>3</sup>/kg in granite at low and medium ionic strength
- 0.01 - 0.1 m<sup>3</sup>/kg recommended for SR 95 study

# Single Pathway Parameters

Element	Kd (m <sup>3</sup> /kg)			
	Distribution	Minimum	Maximum	Most Likely
HTO	Discrete	0	0	n/a
I	Discrete	0	0	n/a
Sr	LogUniform	1.00E-06	1.00E-03	n/a
Co	LogUniform	8.00E-04	2.00E-02	n/a
Tc	Triangular	0.05	2	0.2
Am	Triangular	0.05	5	0.5

Recovery data not available for Tc and Am

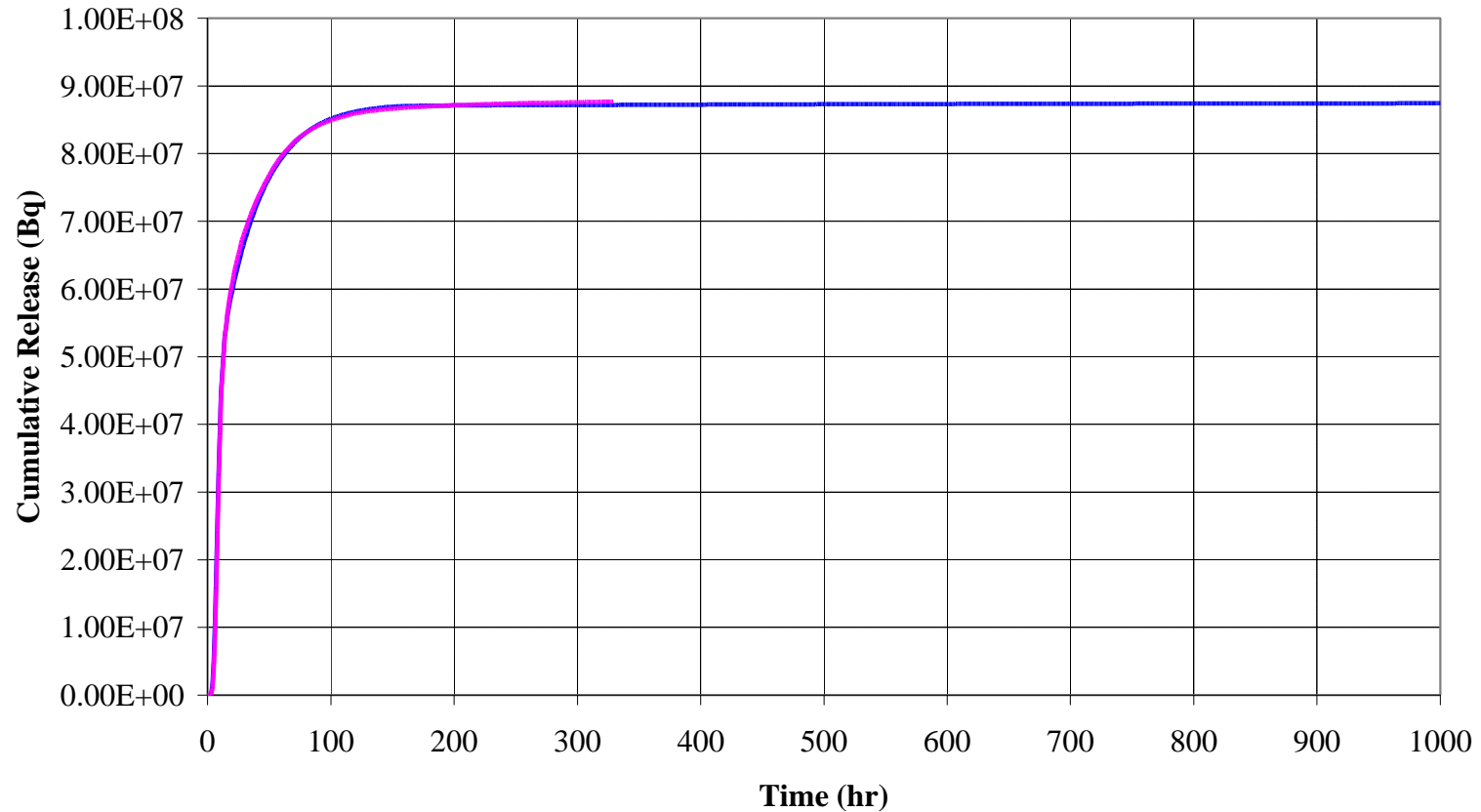
## Results for HTO

- Error Measures Used to Constrain Pathway Properties
- 1500 stochastic simulations



# Realization 624 - HTO Breakthrough

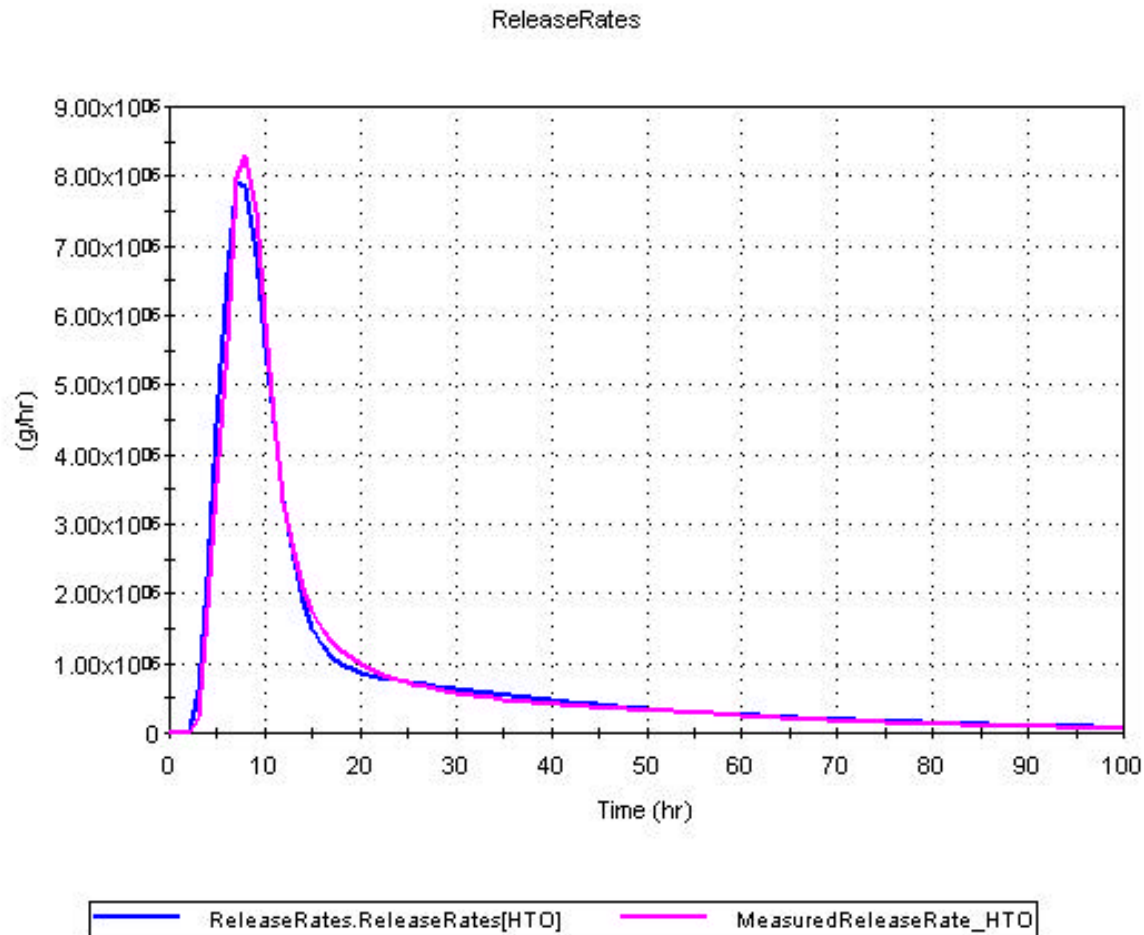
HTO Cumulative Release: Realization 624



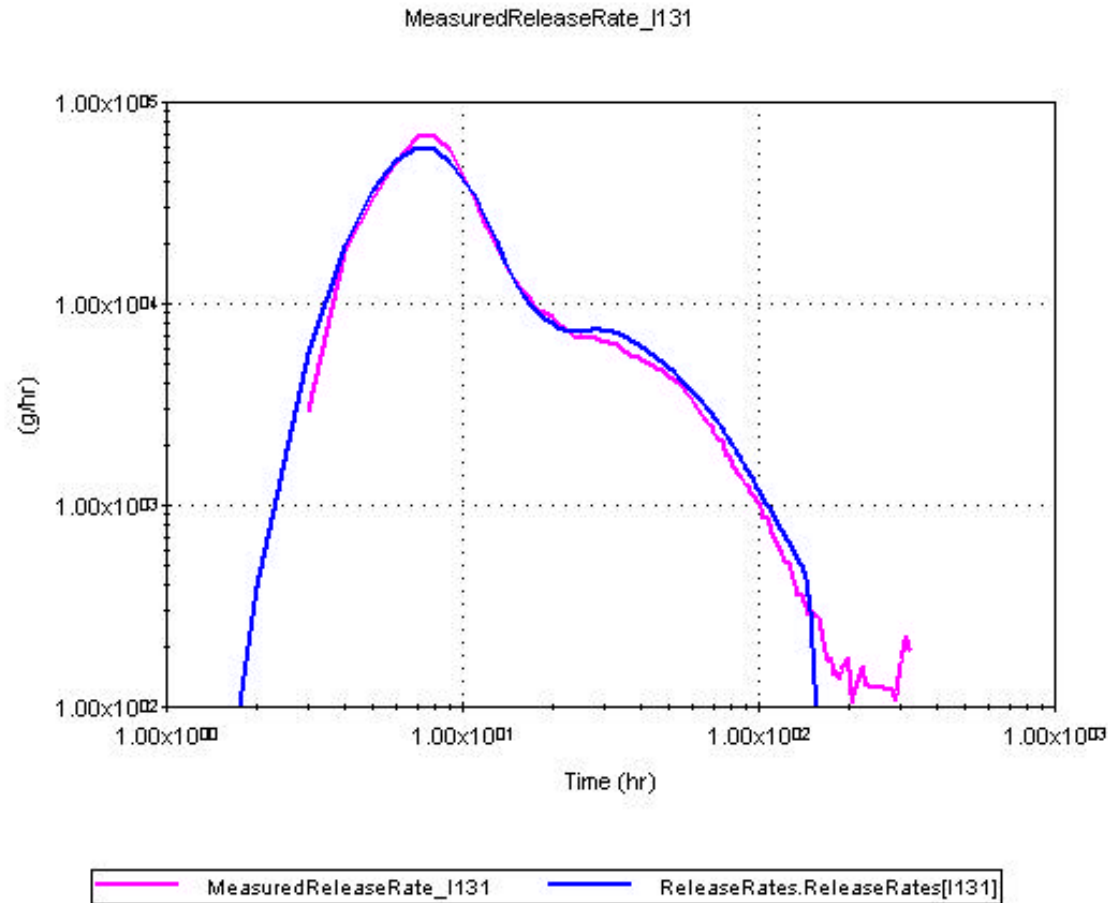
— MassRelease.MassRelease[HTO] [g] — MeasuredCum\_HTO [g]

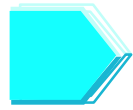


# Realization 624 - HTO Breakthrough



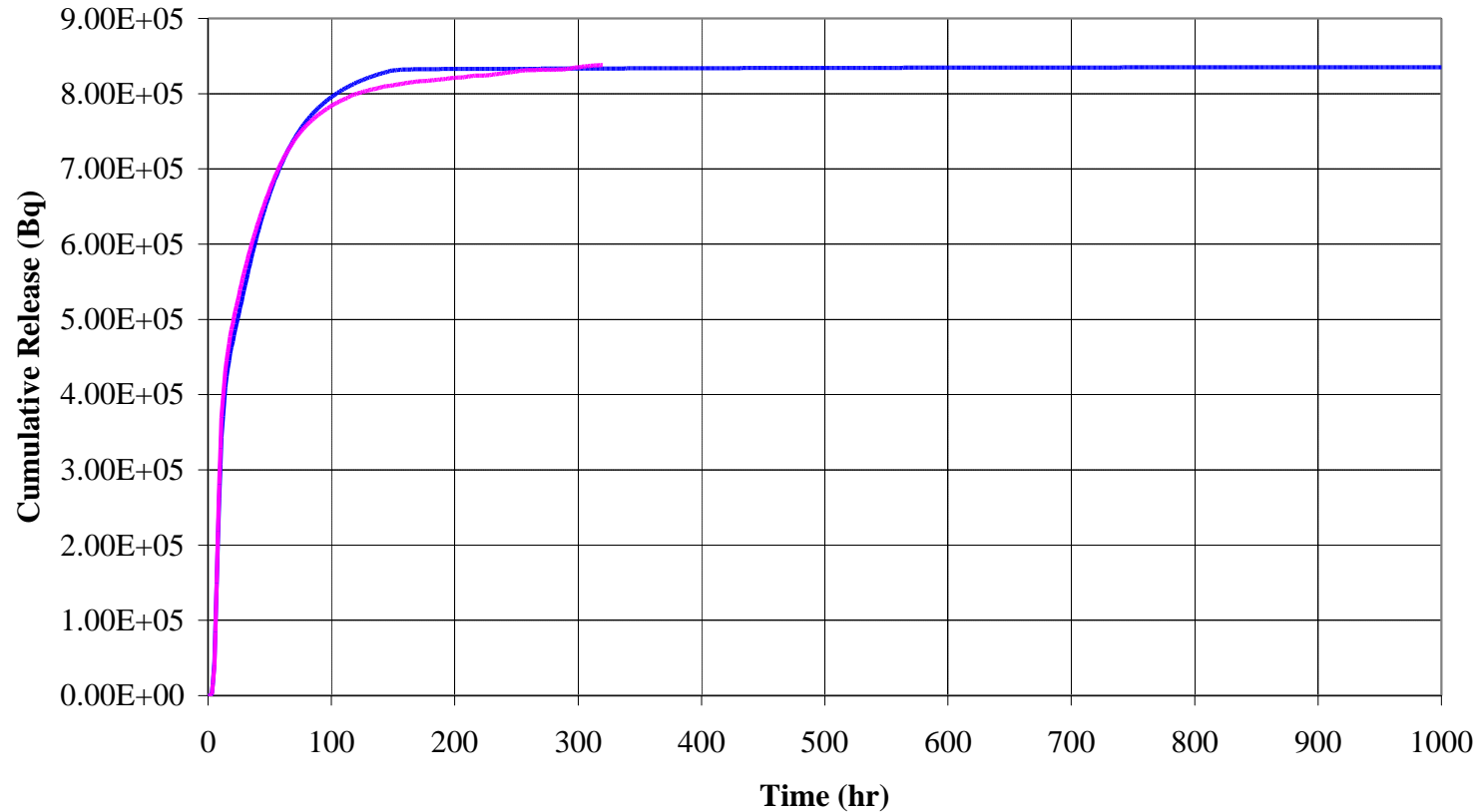
# Realization 624 - I-131 Breakthrough





# Realization 624 - I-131 Breakthrough

HTO Cumulative Release: Realization 624



— MassRelease.MassRelease[I131] [g] — MeasuredCum\_I131 [g]

# 20 “Good Fit” Pathway Realizations STT-1b HTO Breakthrough

Real (-)	Error Measure	Aperture (mm)	Travel Time (hr)	Dispersion (m)	Breccia		Mylonite		RockMass	
					Dmax (mm)	Porosity (-)	Dmax (mm)	Porosity (-)	Dmax (mm)	Porosity (-)
624	12.81%	0.0955	0.8771	0.5	2.4473	0.1186	11.3090	0.0187	52.0950	0.0030
1477	14.76%	0.0590	0.9629	0.5	0.6193	0.2739	14.6100	0.0106	29.9870	0.0027
292	16.78%	0.0671	0.5599	0.5	2.5381	0.1411	2.7768	0.0177	73.2990	0.0050
845	20.23%	0.0259	0.5909	0.5	0.6442	0.2098	16.8330	0.0071	91.2690	0.0010
602	21.28%	0.0430	0.5142	0.5	0.6608	0.3976	11.0030	0.0077	41.5360	0.0035
745	21.31%	0.0730	1.1674	0.5	2.4587	0.0678	1.6373	0.0157	78.2870	0.0024
731	22.80%	0.0632	0.5749	0.5	1.8408	0.1847	8.7847	0.0182	81.0910	0.0014
1084	22.95%	0.0679	1.0613	0.5	1.9541	0.0760	7.3231	0.0092	99.1820	0.0039
478	23.10%	0.0454	1.3132	0.5	1.5920	0.0477	8.7775	0.0100	98.1620	0.0025
1004	25.60%	0.0224	0.7993	0.5	1.0225	0.0734	19.7830	0.0089	89.4160	0.0016
893	25.83%	0.0509	1.3740	0.5	3.0949	0.0257	19.4290	0.0060	25.8680	0.0046
361	26.13%	0.0838	1.2664	0.5	0.6257	0.2397	16.9440	0.0052	58.1330	0.0013
695	27.28%	0.0112	0.5499	0.2	1.2933	0.0379	0.4726	0.0137	77.6840	0.0030
644	27.86%	0.0230	1.0208	0.5	0.4752	0.1097	8.4663	0.0087	29.4220	0.0047
1221	31.83%	0.0832	1.3865	0.5	2.0364	0.0771	8.6703	0.0192	36.0590	0.0014
625	33.70%	0.0869	1.0240	0.5	0.6912	0.2782	6.7990	0.0117	33.9660	0.0027
640	35.20%	0.0174	0.8084	0.5	0.7253	0.0772	1.0834	0.0161	90.1220	0.0017
1452	35.48%	0.0465	0.7614	0.5	0.6504	0.2279	15.1800	0.0057	90.8690	0.0045
1269	36.55%	0.0424	0.6381	0.2	3.3784	0.0497	15.4600	0.0196	93.8030	0.0014
760	37.66%	0.0361	0.7460	0.2	0.5748	0.1969	3.7313	0.0114	88.0550	0.0035
<b>min</b>	<b>n/a</b>	<b>0.0112</b>	<b>0.5142</b>	<b>0.2</b>	<b>0.4752</b>	<b>0.0257</b>	<b>0.4726</b>	<b>0.0052</b>	<b>25.8680</b>	<b>0.0010</b>
<b>max</b>	<b>n/a</b>	<b>0.0955</b>	<b>1.3865</b>	<b>0.5</b>	<b>3.3784</b>	<b>0.3976</b>	<b>19.7830</b>	<b>0.0196</b>	<b>99.1820</b>	<b>0.0050</b>

# Uniqueness of Transport Parameters for STT-1b Measured Breakthrough

- The range of values for each parameter for the top 20 simulations is nearly as wide as the range of input parameters !!!
- Results re-interpreted in terms of  $\beta$  and other index measures to better constrain transport properties.

# Transport Pathway Measures

Parameter	Units	Definition
$a_r$	$\text{mm}^2 / \text{mm}^3$	$2 / (\text{aperture} + 2 * D_{\text{max}})$
F factor (or $\beta$ )	hr/m	$2 * \text{travel time} / \text{aperture}$
$k$	$(\text{m}^2/\text{hr})^{0.5}$	$\text{porosity} * (D_{\text{eff}} * R_{\text{matrix}})^{1/2}$
$k * F$	$\text{hr}^{0.5}$	see above
$k * F * t$	$\text{hr}^{1.5}$	see above
Volume Ratio	hr	Matrix Volume / Flowing Volume * travel time * Retardation $(2 * D_{\text{max}} + e) n / e * t * R$

# HTO Transport Pathway Properties

## HTO

		a_r	F factor	k	k*F	k*F *time	Volume Ratio
All 1500	min	0.24838	10.735	2.38E-06	4.515E-05	2.820E-05	0.11
	max	34.0588	292.924	8.48E-05	1.976E-02	2.856E-02	317.12
Top 10	min	0.3889	16.678	1.01E-05	4.604E-04	2.794E-04	4.46
	max	1.5413	71.454	8.44E-05	2.031E-03	1.827E-03	6.49
Proportion of Range		3.41%	19.41%	90.06%	7.97%	5.43%	0.64%

# I-131 Transport Pathway Properties

## I-131

		a_r	F factor	k	k*F	k*F *time	Volume Ratio
All 1500	min	0.248	10.73	2.380E-06	4.515E-05	2.820E-05	0.11
	max	34.059	292.92	8.480E-05	1.976E-02	2.856E-02	317.12
Top 10	min	0.282	22.33	2.949E-06	2.917E-04	2.014E-04	3.73
	max	2.786	99.68	8.031E-05	3.052E-03	1.753E-03	5.16
Proportion of Range		7.41%	27.41%	93.87%	14.00%	5.44%	0.45%



# Sr-85 Transport Pathway Properties

## Sr-85

		a_r	F factor	k	k*F	k*F *time	Volume Ratio
All 1500	min	0.248	10.73	3.527E-06	1.038E-04	8.428E-05	0.22
	max	34.059	292.92	2.265E-04	5.148E-02	7.232E-02	2045.12
Top 10	min	0.272	15.93	1.437E-05	7.223E-04	4.158E-04	10.86
	max	2.511	220.59	1.312E-04	7.101E-03	7.417E-03	14.23
Proportion of Range		6.62%	72.52%	52.42%	12.42%	9.69%	0.16%

# Co-58 Transport Pathway Properties

## Co-58

		a_r	F factor	k	k*F	k*F *time	Volume Ratio
All 1500	min	0.248	10.73	3.266E-05	8.520E-04	5.123E-04	3.70
	max	34.059	292.92	9.419E-04	2.138E-01	2.897E-01	33188.69
Top 10	min	0.587	48.11	6.119E-05	1.015E-02	1.278E-02	458.60
	max	6.026	200.27	4.191E-04	6.023E-02	6.565E-02	930.64
Proportion of Range		16.09%	53.92%	39.37%	23.52%	18.28%	1.42%

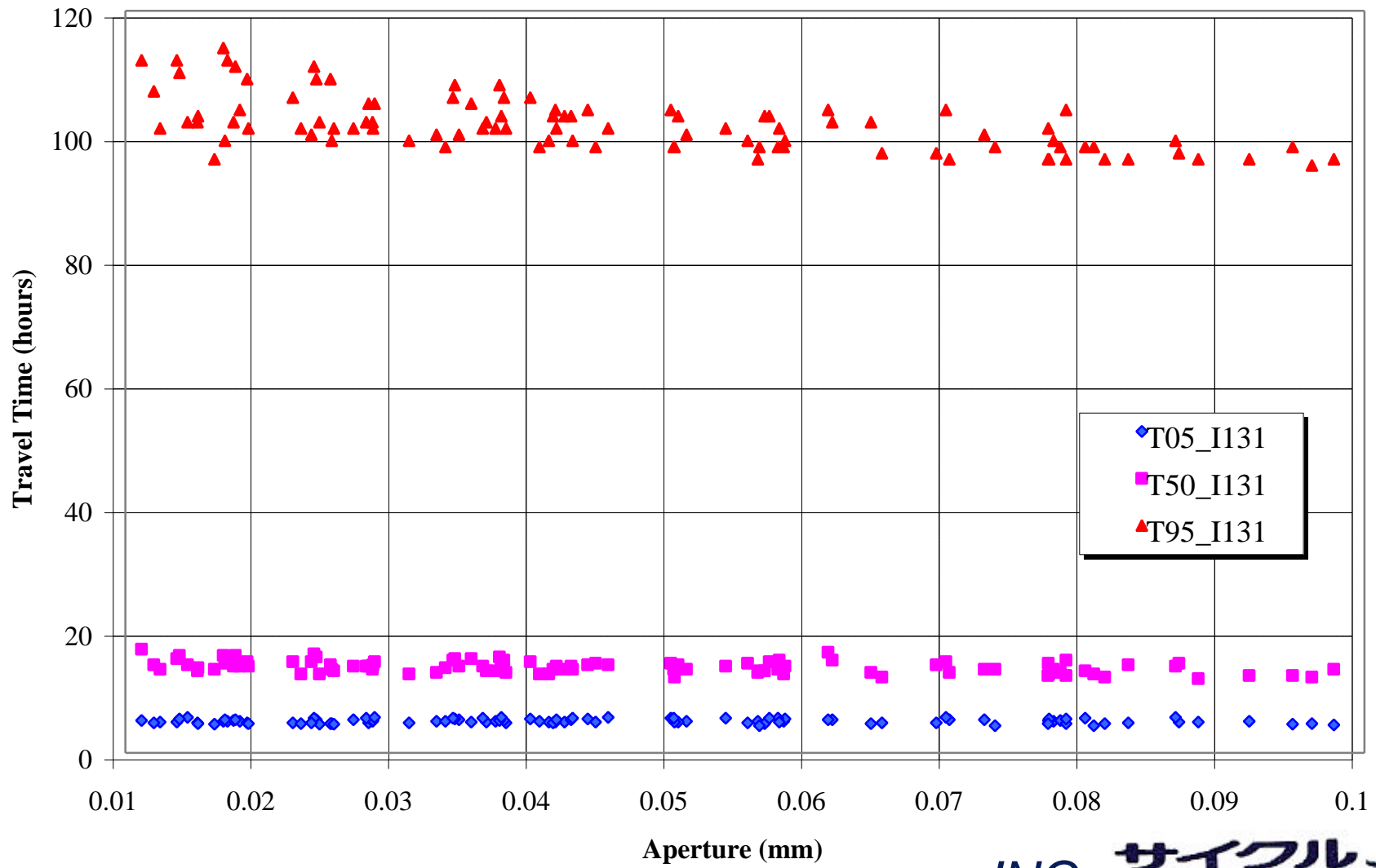
## Refined Single Path Sensitivity

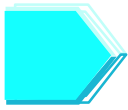
- **Range for Mobile/Immobile Volume Ratio 3.5 to 6.5 hr<sup>0.5</sup> (Best fit values from the previous simulations)(previous range was 0.11 to 317)**
- **Transfer rate 0.01 to 1.0 (triangular) (was previously constant at 0.1)**
- **The dispersion length was set to 0.2m or 0.5m (the best fit values from the previous simulations) (Range was 0.05 m to 1.0 m)**

# Results from Simulations - 10 best

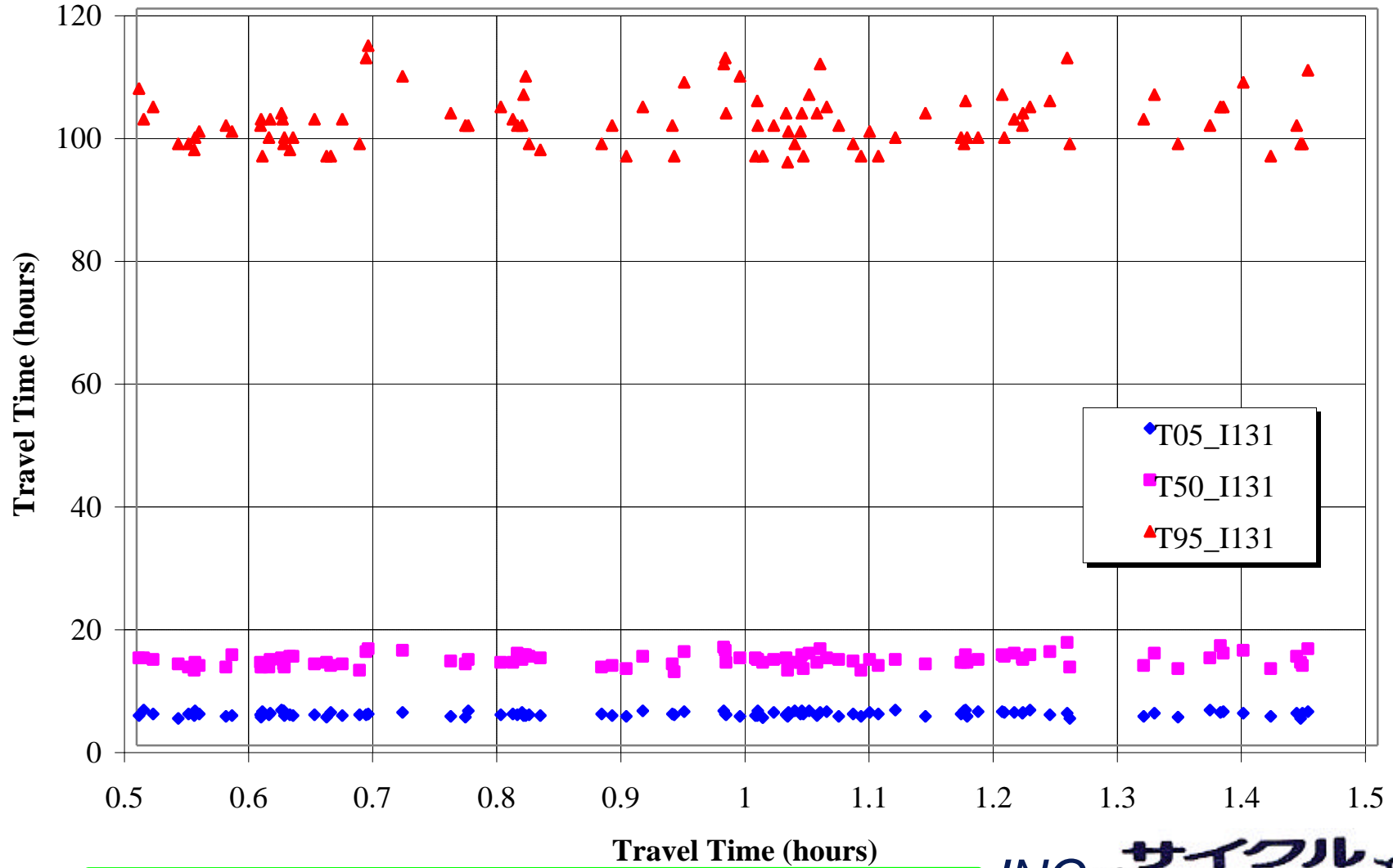
Real (-)	Error Measure	Aperture (mm)	Travel Time (hr)	Dispersion (m)	Breccia / Infillings		Mylonite / Altered Wall Rock		RockMass	
					Dmax (mm)	Porosity (-)	Dmax (mm)	Porosity (-)	Dmax (mm)	Porosity (-)
372	11.90%	0.017223	1.1992	0.2	2.7841	0.0120	0.3928	0.0100	25.272	0.002293
220	13.78%	0.061343	1.2072	0.2	2.9969	0.0423	3.5883	0.0146	28.353	0.004546
386	14.24%	0.077032	1.4347	0.2	2.4600	0.0509	18.0110	0.0136	61.577	0.004236
225	14.31%	0.044159	0.81627	0.5	3.8445	0.0390	19.1550	0.0055	64.103	0.003629
252	15.40%	0.027987	1.2138	0.2	1.9358	0.0281	14.9510	0.0060	71.345	0.002044
309	15.81%	0.023513	0.57681	0.5	2.2913	0.0493	16.8250	0.0077	20.117	0.003246
199	15.98%	0.086519	0.62345	0.5	2.3158	0.1739	15.5170	0.0098	71.077	0.004141
396	16.52%	0.055197	0.62606	0.5	3.6638	0.0662	16.3610	0.0136	64.104	0.002138
6	17.65%	0.068892	0.82531	0.5	3.1667	0.0712	19.2720	0.0059	40.532	0.004477
376	17.74%	0.035114	1.2359	0.2	3.5028	0.0177	3.1379	0.0132	41.868	0.004563
2	18.38%	0.082838	0.9986	0.5	1.1449	0.1864	16.4610	0.0052	82.643	0.0042
299	18.83%	0.077415	1.1643	0.2	1.9401	0.0794	3.8506	0.0118	62.918	0.0029
74	18.98%	0.03423	1.0906	0.2	0.7732	0.0997	16.0100	0.0061	72.595	0.004881
106	19.08%	0.063242	0.86335	0.5	2.1433	0.0918	12.7310	0.0107	32.894	0.001694
306	19.20%	0.035705	0.72015	0.5	0.3888	0.3788	6.6946	0.0075	35.862	0.004918
55	19.50%	0.061041	1.3734	0.2	0.2810	0.3995	7.5830	0.0142	34.615	0.003829
394	19.56%	0.058875	0.78661	0.5	3.8099	0.0530	15.8250	0.0152	25.671	0.001808
4	19.75%	0.044805	0.62563	0.5	2.6309	0.0796	9.4470	0.0165	35.09	0.001862
288	20.18%	0.055702	0.64256	0.5	2.7259	0.0967	19.1210	0.0129	86.738	0.002666
318	20.50%	0.050762	1.0349	0.2	3.1421	0.0361	18.2810	0.0106	67.131	0.002555
<b>min</b>	<b>n/a</b>	<b>0.0172</b>	<b>0.5768</b>	<b>0.2</b>	<b>0.2810</b>	<b>0.0120</b>	<b>0.3928</b>	<b>0.0052</b>	<b>20.1170</b>	<b>0.0017</b>
<b>max</b>	<b>n/a</b>	<b>0.0865</b>	<b>1.4347</b>	<b>0.5</b>	<b>3.8445</b>	<b>0.3995</b>	<b>19.2720</b>	<b>0.0165</b>	<b>86.7380</b>	<b>0.0049</b>

I-131 T05, T50, T95 versus Aperture for best 100 Realizations



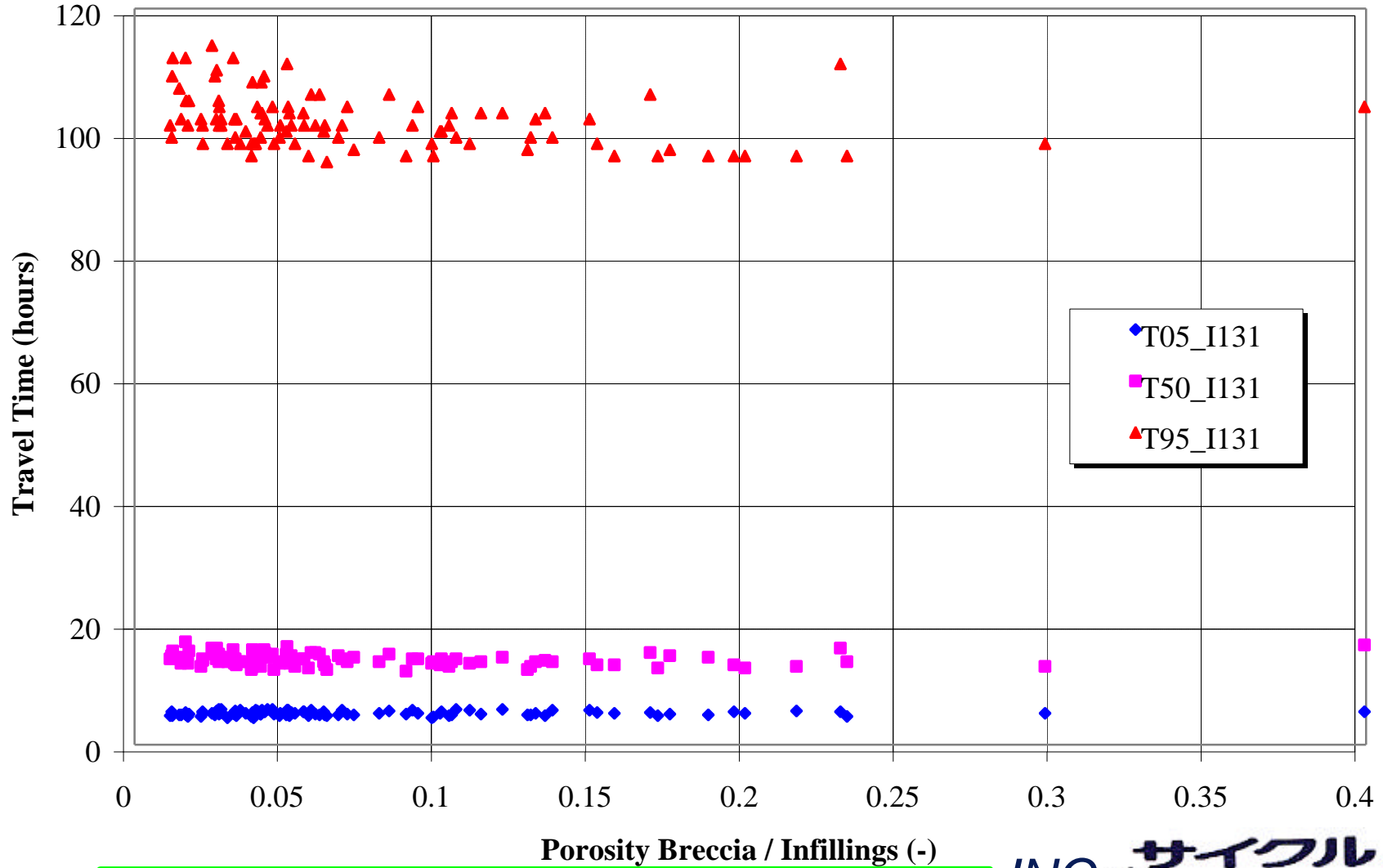


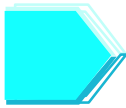
### I-131 T05, T50, T95 versus Advective Travel Time for best 100 Realizations



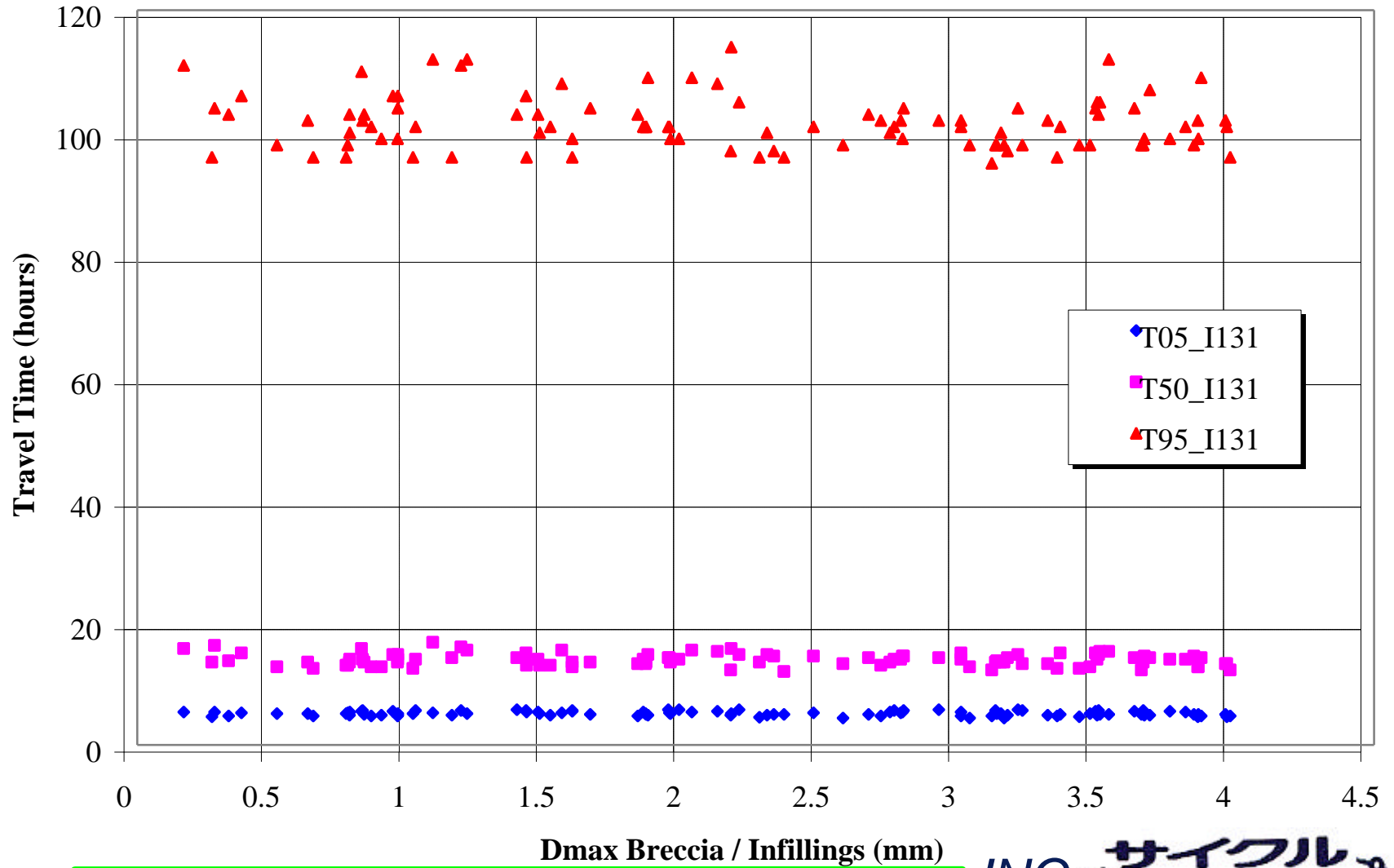


### I-131 T05, T50, T95 versus Breccia / Infilling Porosity for best 100 Realizations



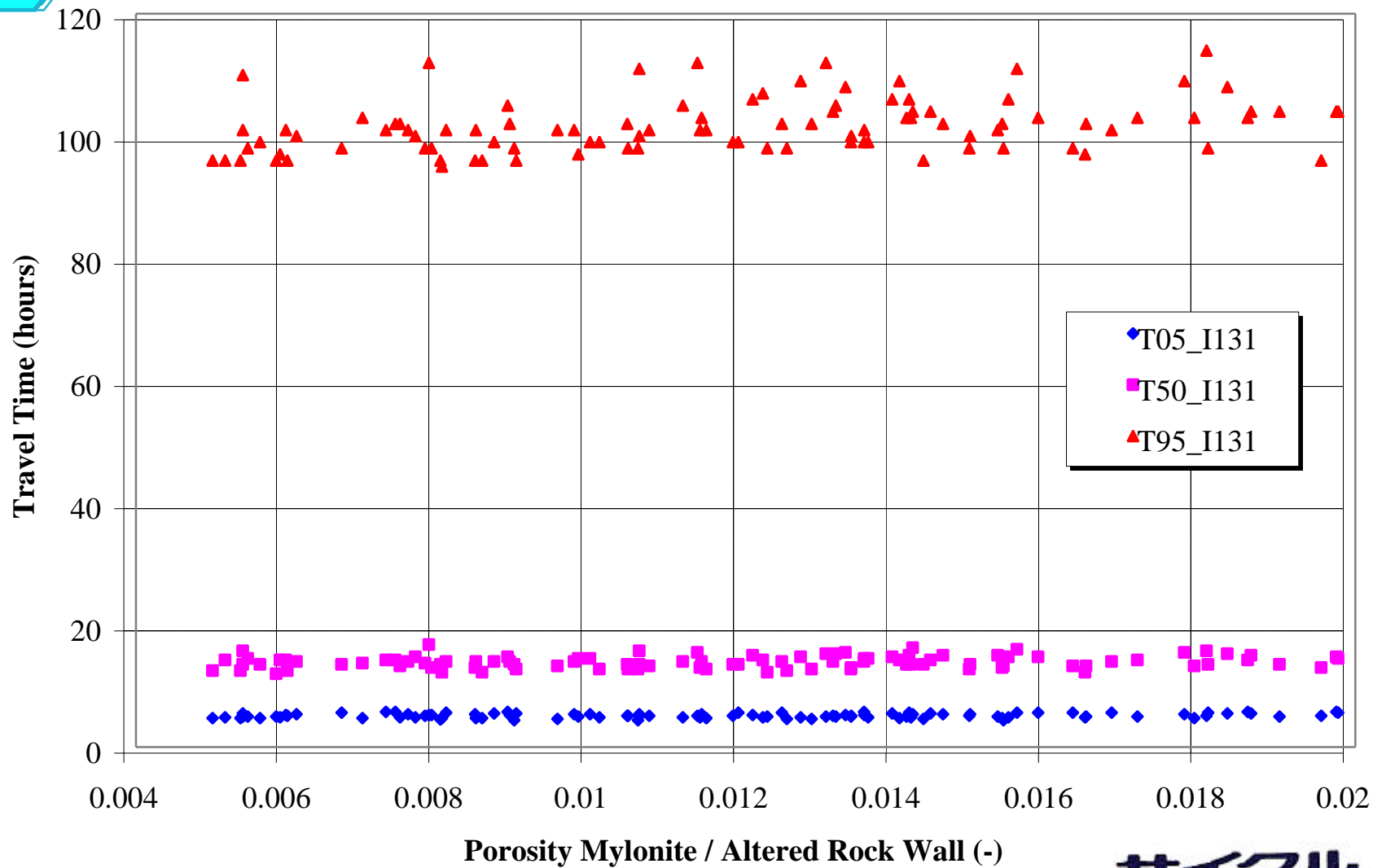


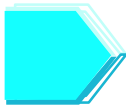
### I-131 T05, T50, T95 versus Breccia / Infilling Dmax for best 100 Realizations



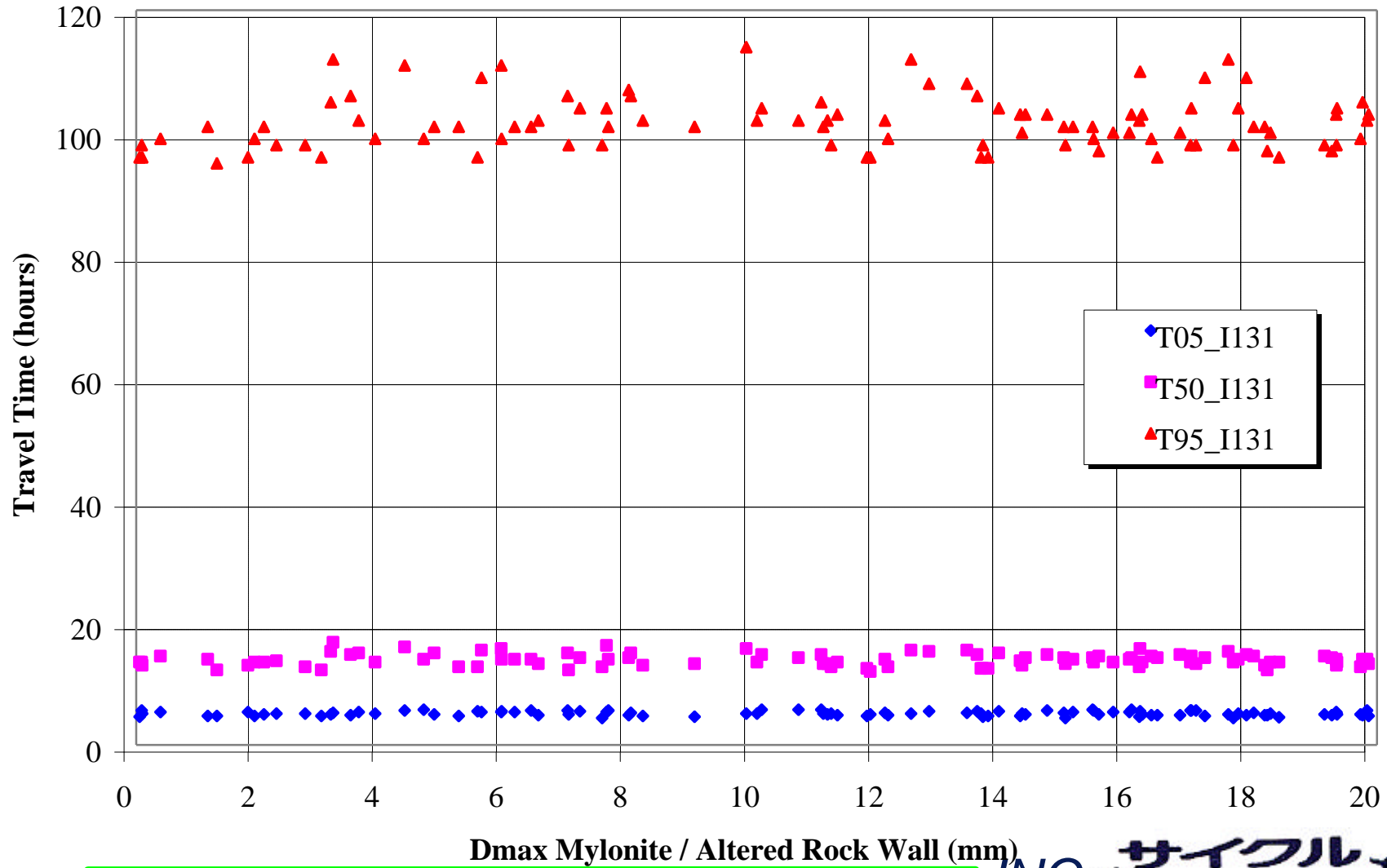


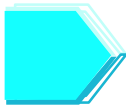
I-131 T05, T50, T95 versus Mylonite/Altered Rock Wall Porosity for best 100 Realizations



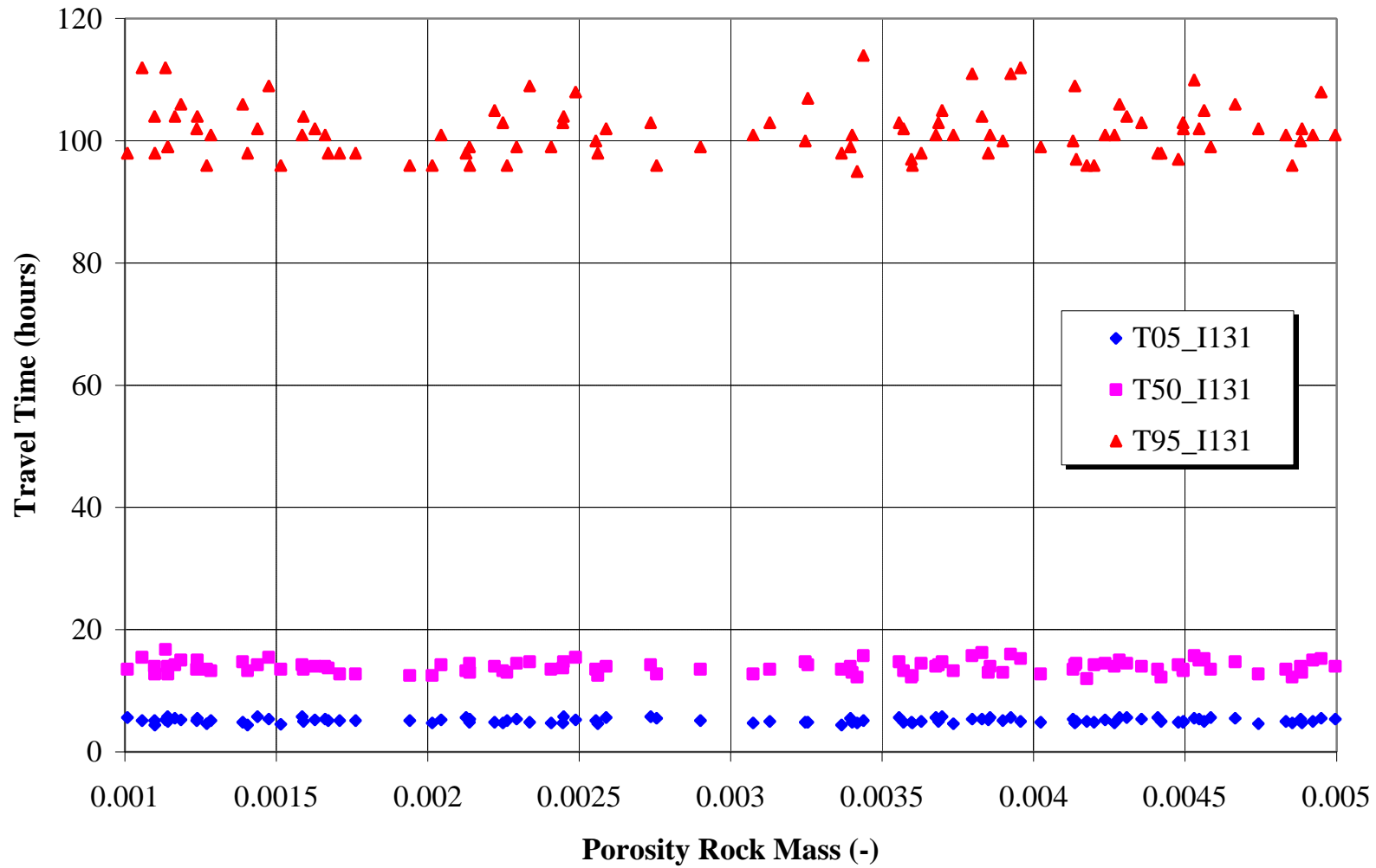


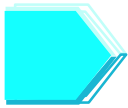
### I-131 T05, T50, T95 versus Mylonite/Altered Rock Wall Dmax for best 100 Realizations



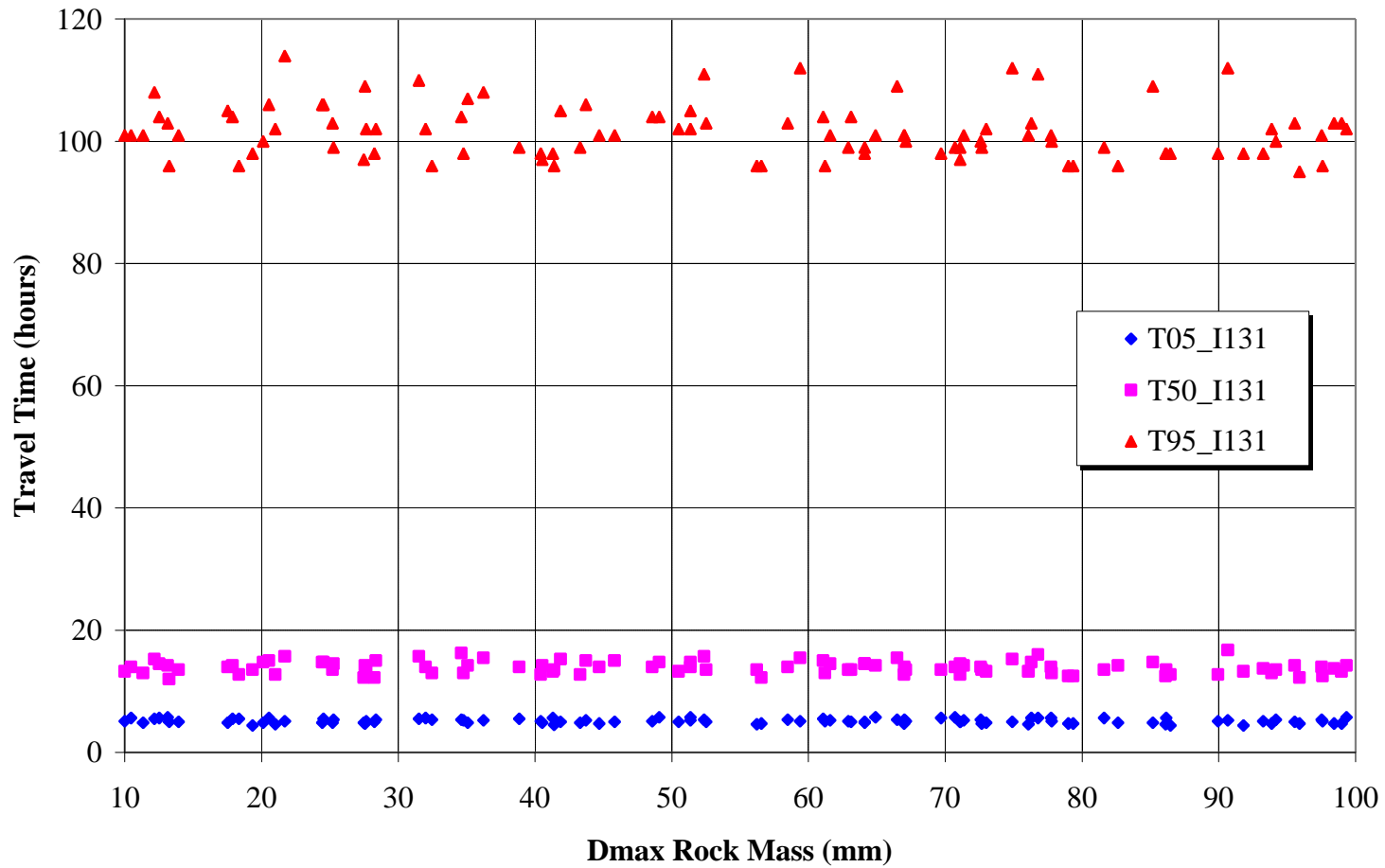


### I-131 T05, T50, T95 versus Rock Mass Porosity for best 100 Realizations



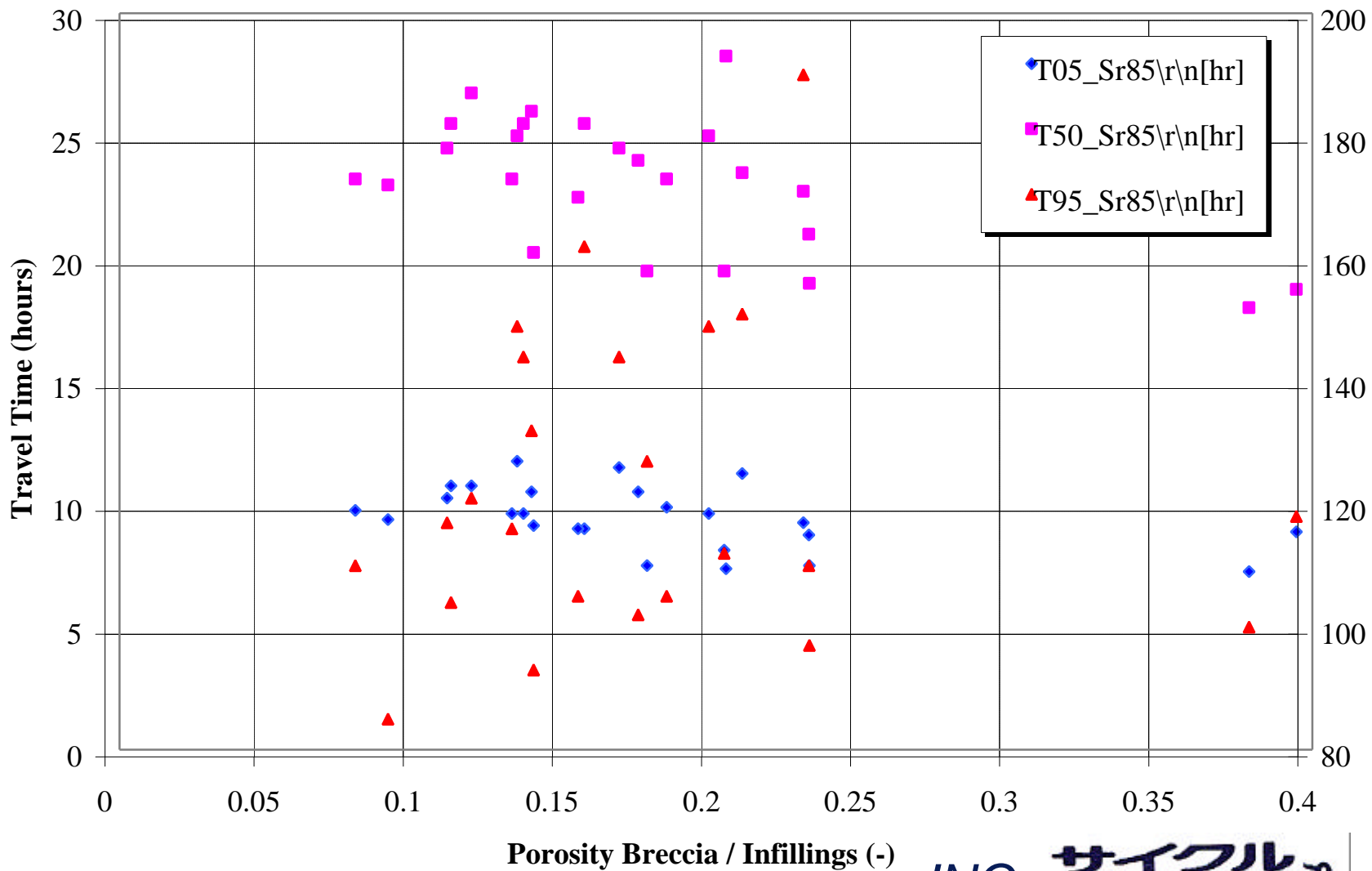


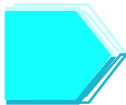
### I-131 T05, T50, T95 versus Rock Mass Dmax for best 100 Realizations



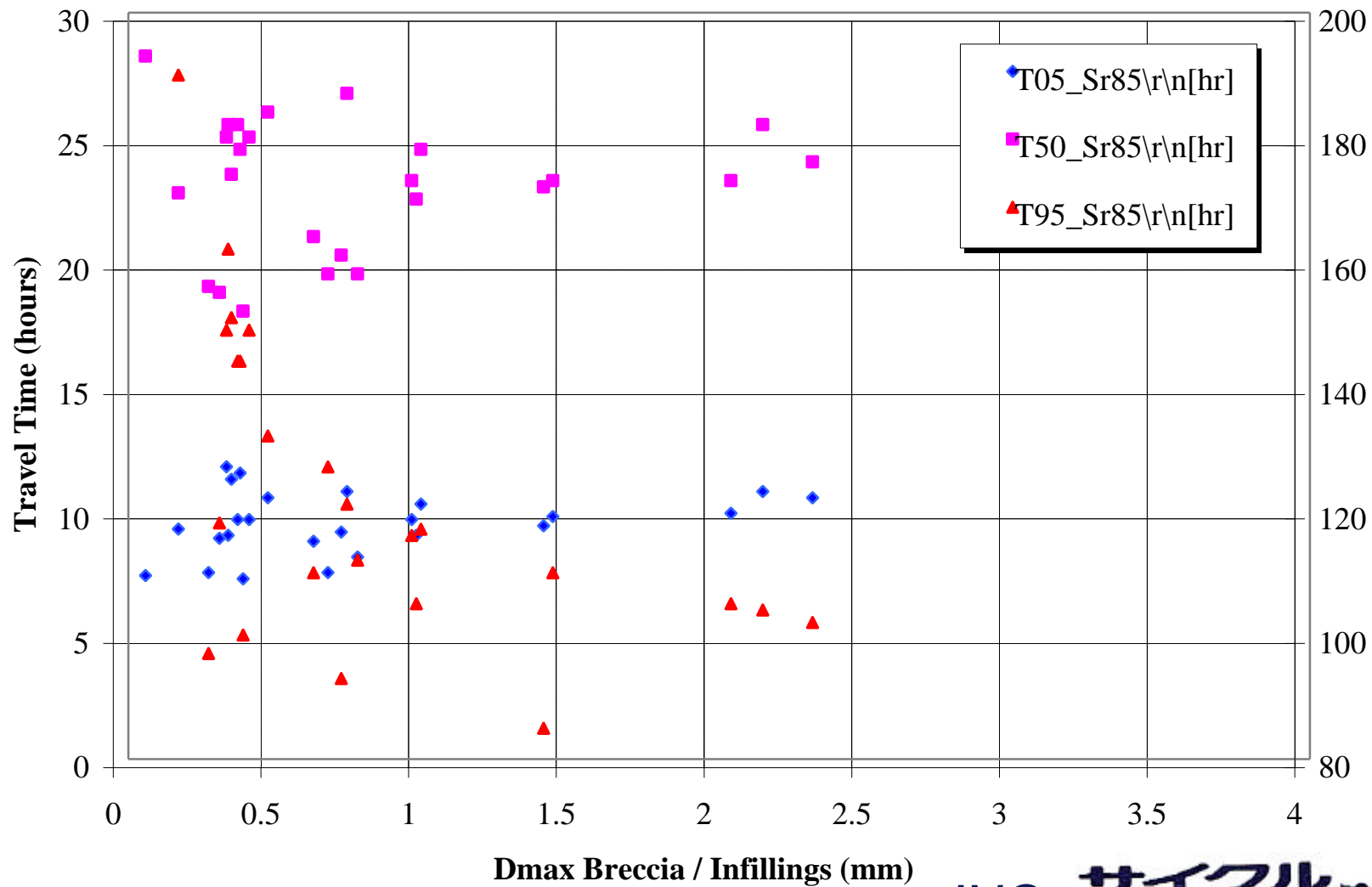


### Sr-85 T05, T50, T95 versus Breccia / Infilling Porosity for best 25 Realizations



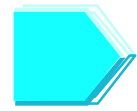


### Sr-85 T05, T50, T95 versus Breccia / Infilling Dmax for best 25 Realizations



## Results of Fit Refinement

- The average error defined previously reduced by the following factors due to limiting the Volume Ratio range
  - HTO - factor of 10.7
  - I-131 - factor of 11.2
  - Sr-85 - factor of 1.7
  - Cs-58 - factor of >1000



## Single Pathway Simulations with Sorbing Tracers

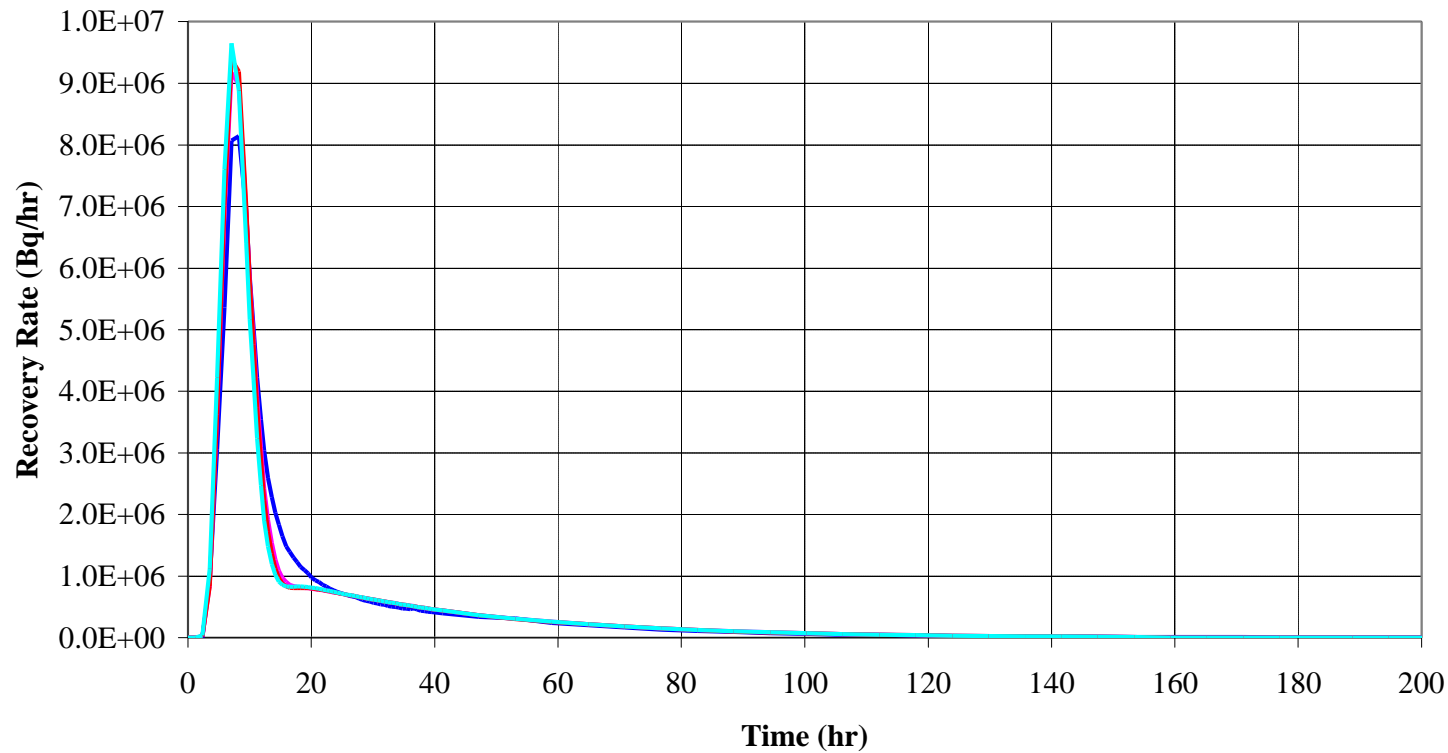
- Run 3 sets of parameters which provided the best fit for HTO & I-131
- Sr-85 Provided similarly good match to HTO and I-131, but required reduced  $K_d$
- Co-58, Tc-99 & Am-241 did not provide good matches with these parameters



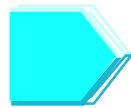
# HTO Breakthrough Realizations 299, 318 & 240

HTO Release Rate

$K_d = 0.0 \text{ m}^3/\text{kg}$



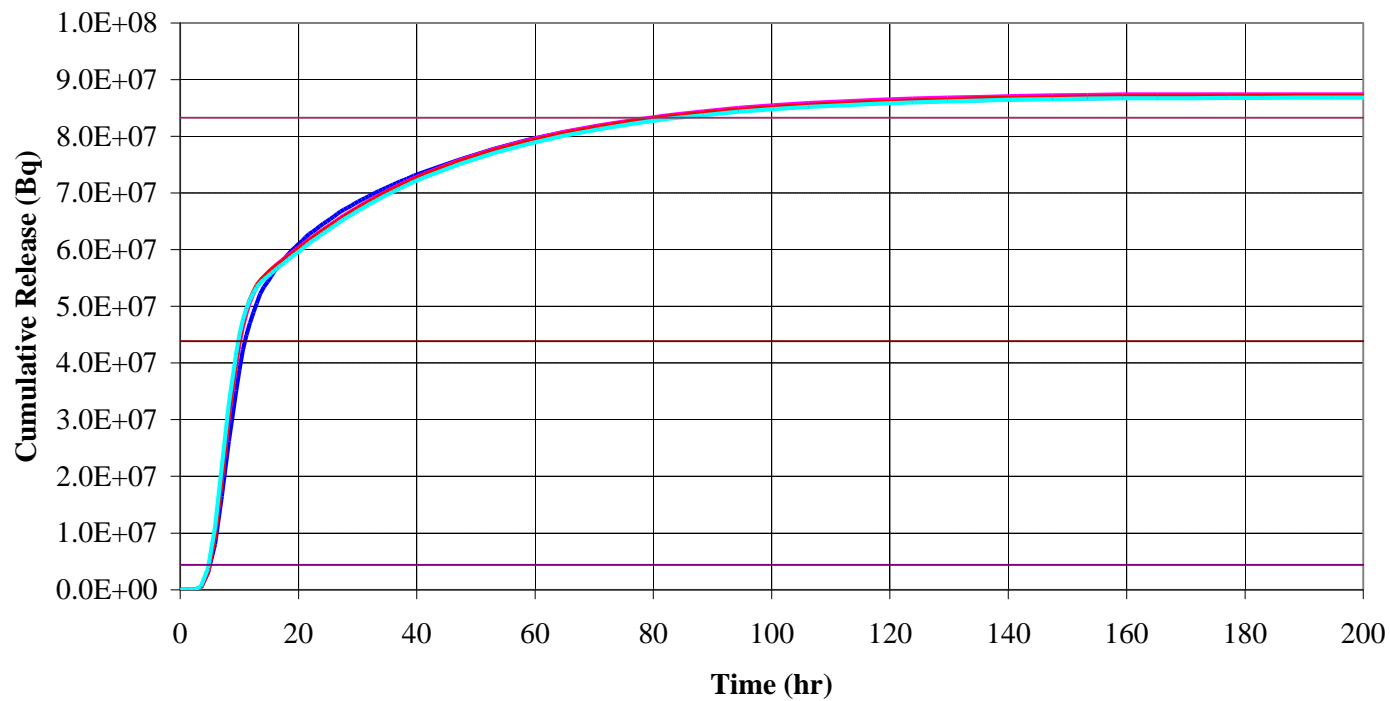
— MeasuredReleaseRate\_HTO [g/hr] — Real 299 ReleaseRates[HTO] [g/hr]  
— Real 318 ReleaseRates[HTO] [g/hr] — Real 240 ReleaseRates[HTO] [g/hr]



# HTO Breakthrough Realizations 299, 318 & 240

$K_d = 0.0 \text{ m}^3/\text{kg}$

HTO Cumulative Release

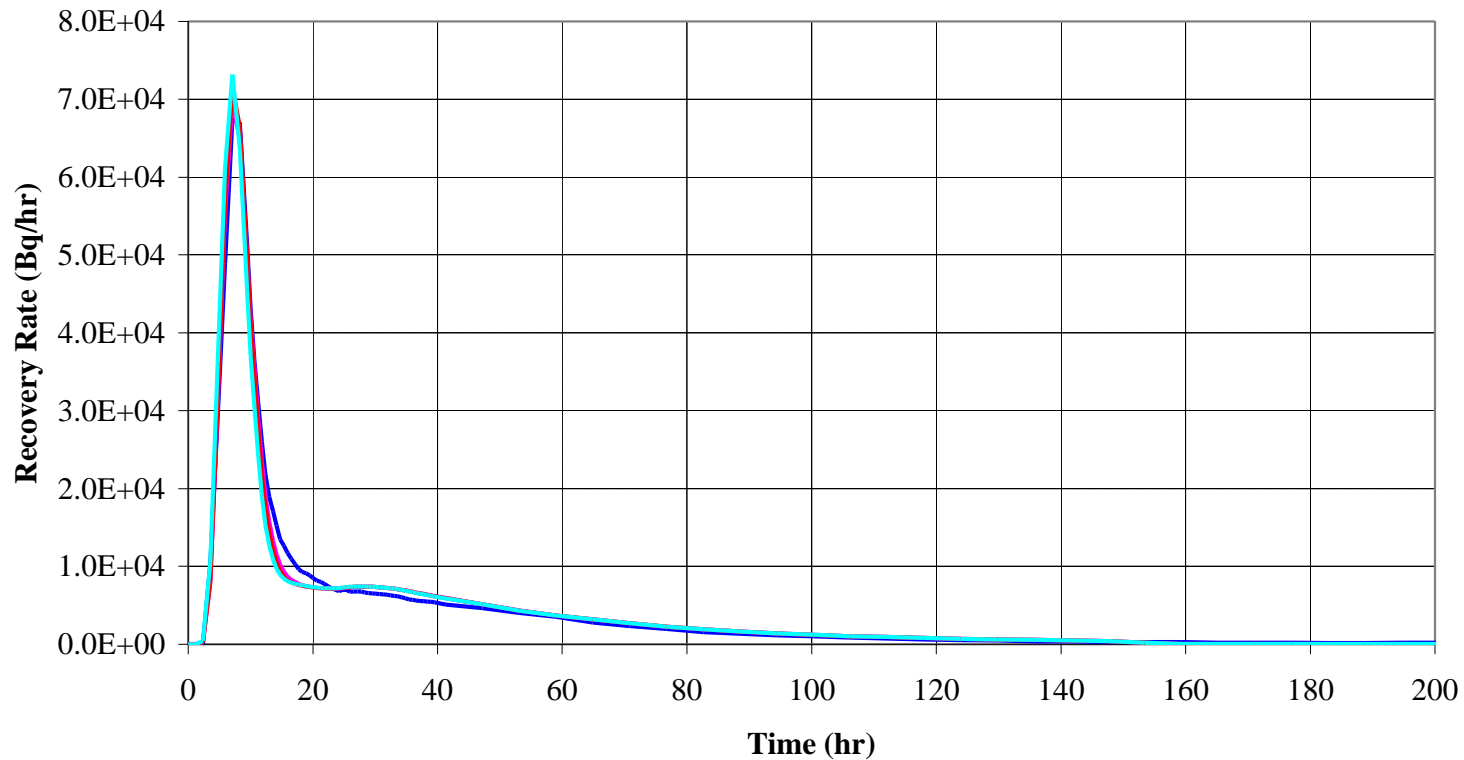




# I-131 Breakthrough Realizations 299, 318 & 240

I-131 Release Rate

$K_d = 0.0 \text{ m}^3/\text{kg}$



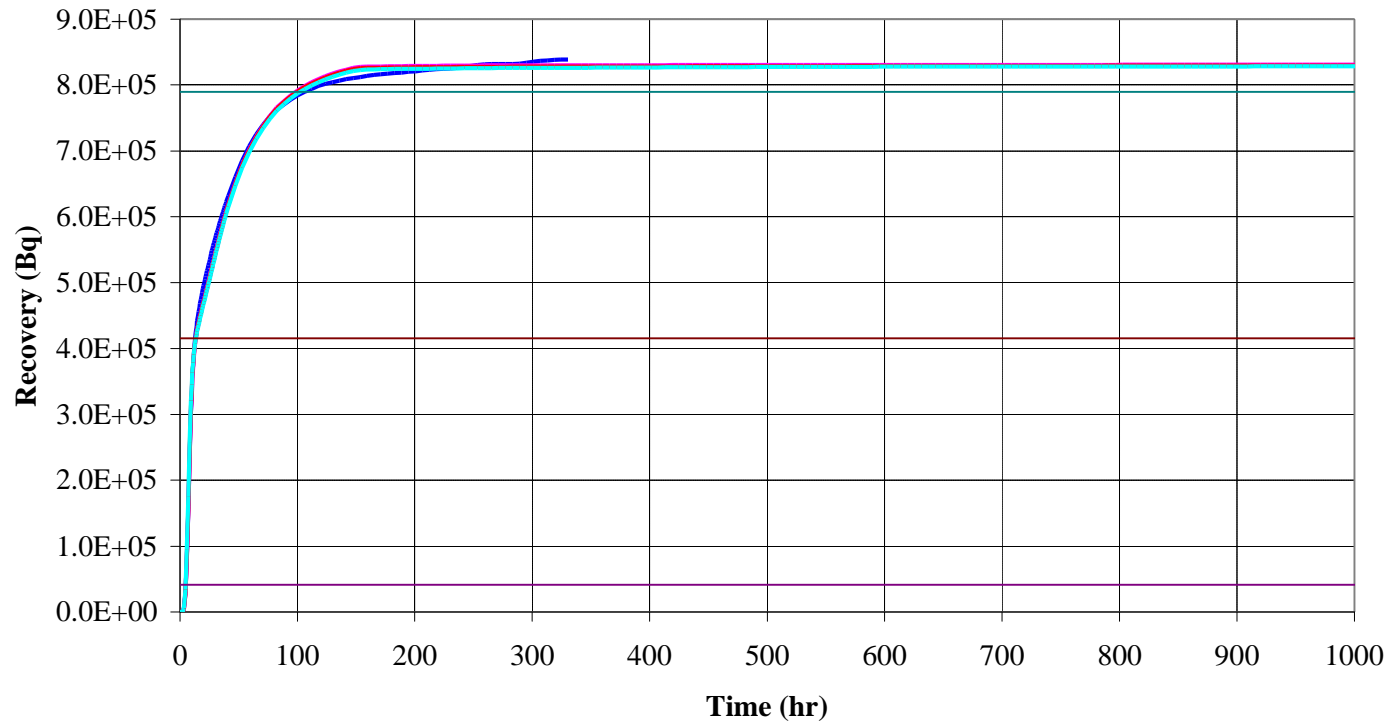
— MeasuredReleaseRate\_I131 [g/hr] — Real 299 ReleaseRates[I131] [g/hr]  
— Real 318 ReleaseRates[I131] [g/hr] — Real 240 ReleaseRates[I131] [g/hr]



# I-131 Breakthrough Realizations 299, 318 & 240

I-131 Cumulative Release

$K_d = 0.0 \text{ m}^3/\text{kg}$



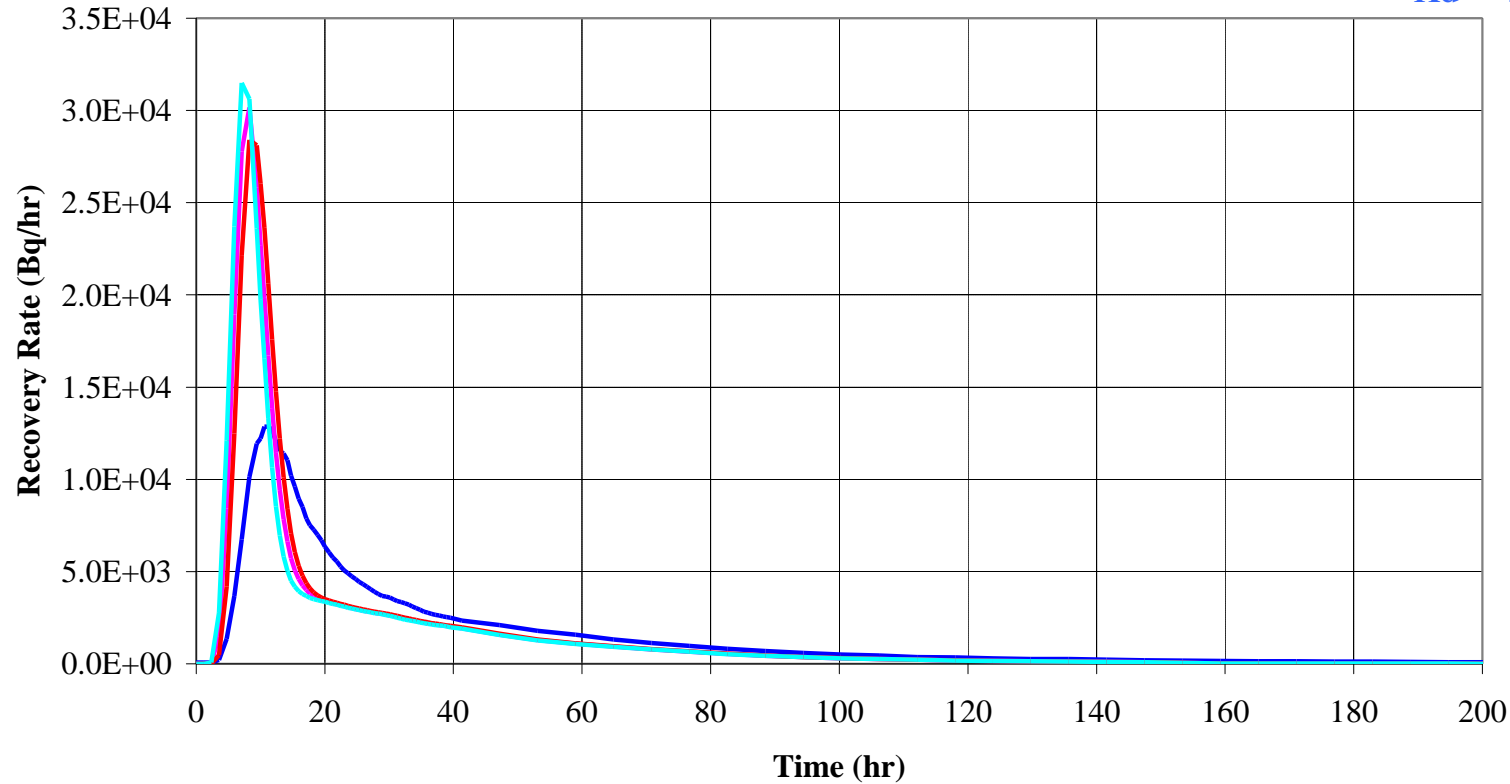
— MeasuredCum\_I131 [g]      — Real 299 MassRelease[I131] [g]  
— Real 318 MassRelease[I131] [g]      — Real 240 MassRelease[I131] [g]



# Sr-85 Breakthrough Realizations 299, 318 & 240

Sr-85 Release Rate

$K_d = 4.7e-6 \text{ m}^3/\text{kg}$



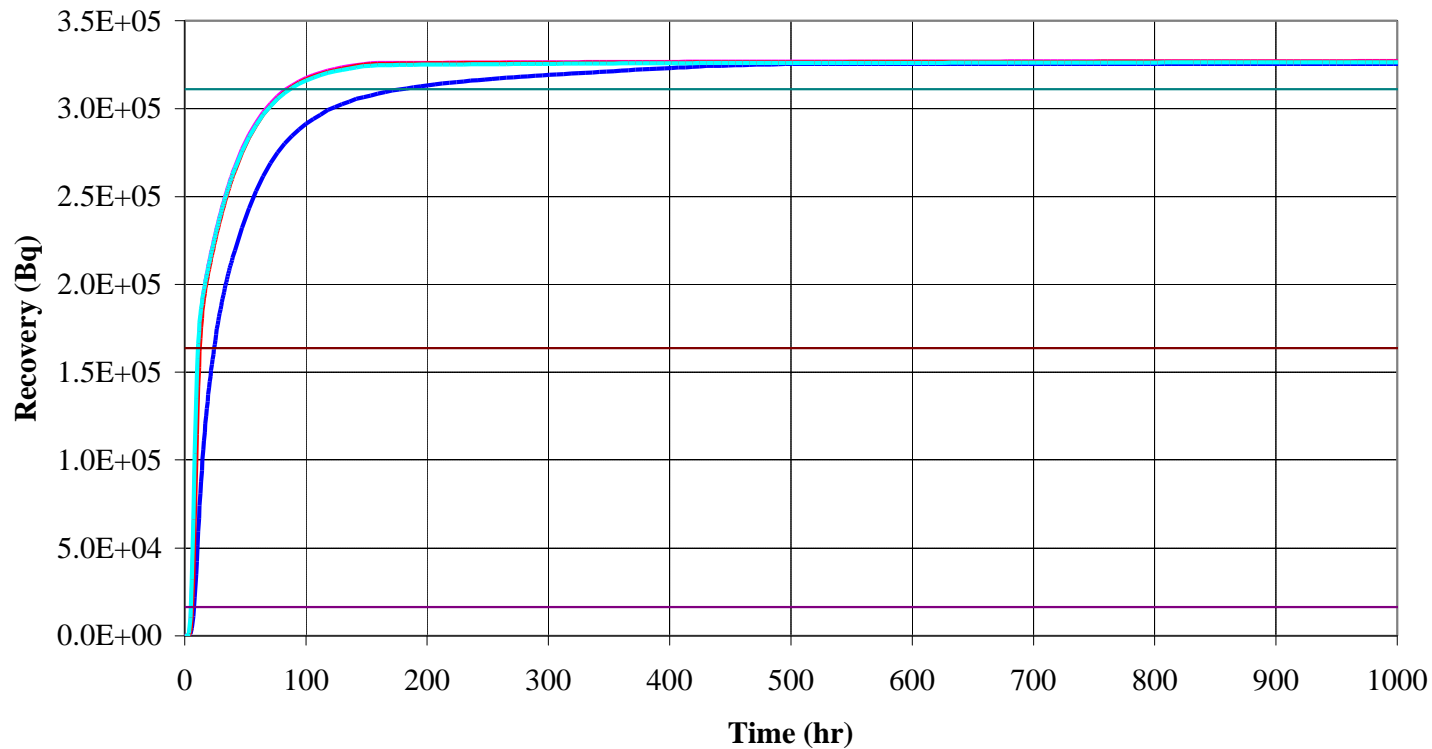
— MeasuredReleaseRate\_Sr85 [g/hr] — Real 299 ReleaseRates[Sr85] [g/hr]  
— Real 318 ReleaseRates[Sr85] [g/hr] — Real 240 ReleaseRates[Sr85] [g/hr]



# Sr-85 Breakthrough Realizations 299, 318 & 240

Sr-85 Cumulative Release

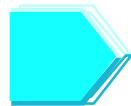
$K_d = 4.7e-6 \text{ m}^3/\text{kg}$



— MeasuredCum\_Sr85 [g]      — Real 299 MassRelease[Sr85] [g]  
— Real 318 MassRelease[Sr85] [g]      — Real 240 MassRelease[Sr85] [g]

923 1089.H13

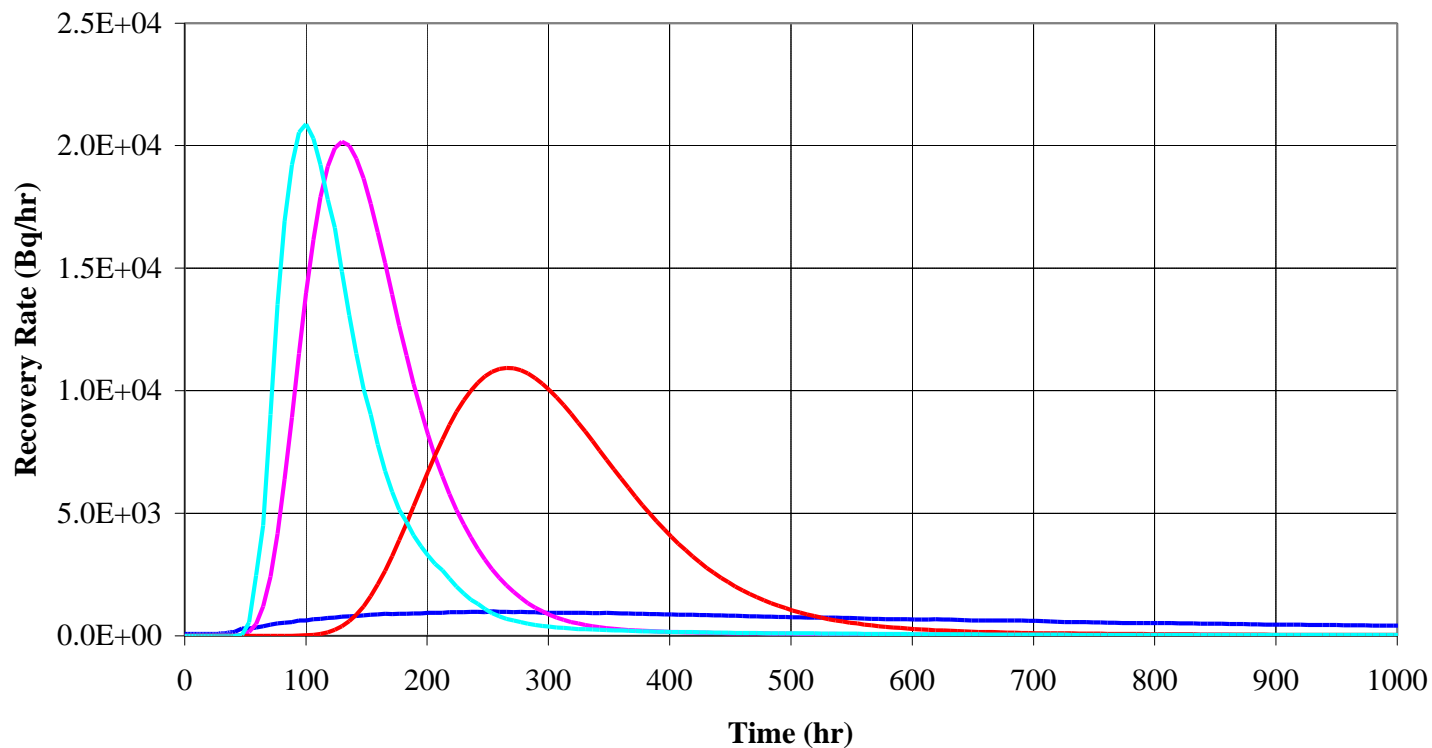




# Co-58 Breakthrough Realizations 299, 318 & 240

Co-58 Release Rate

$K_d = 8.0e-4 \text{ m}^3/\text{kg}$

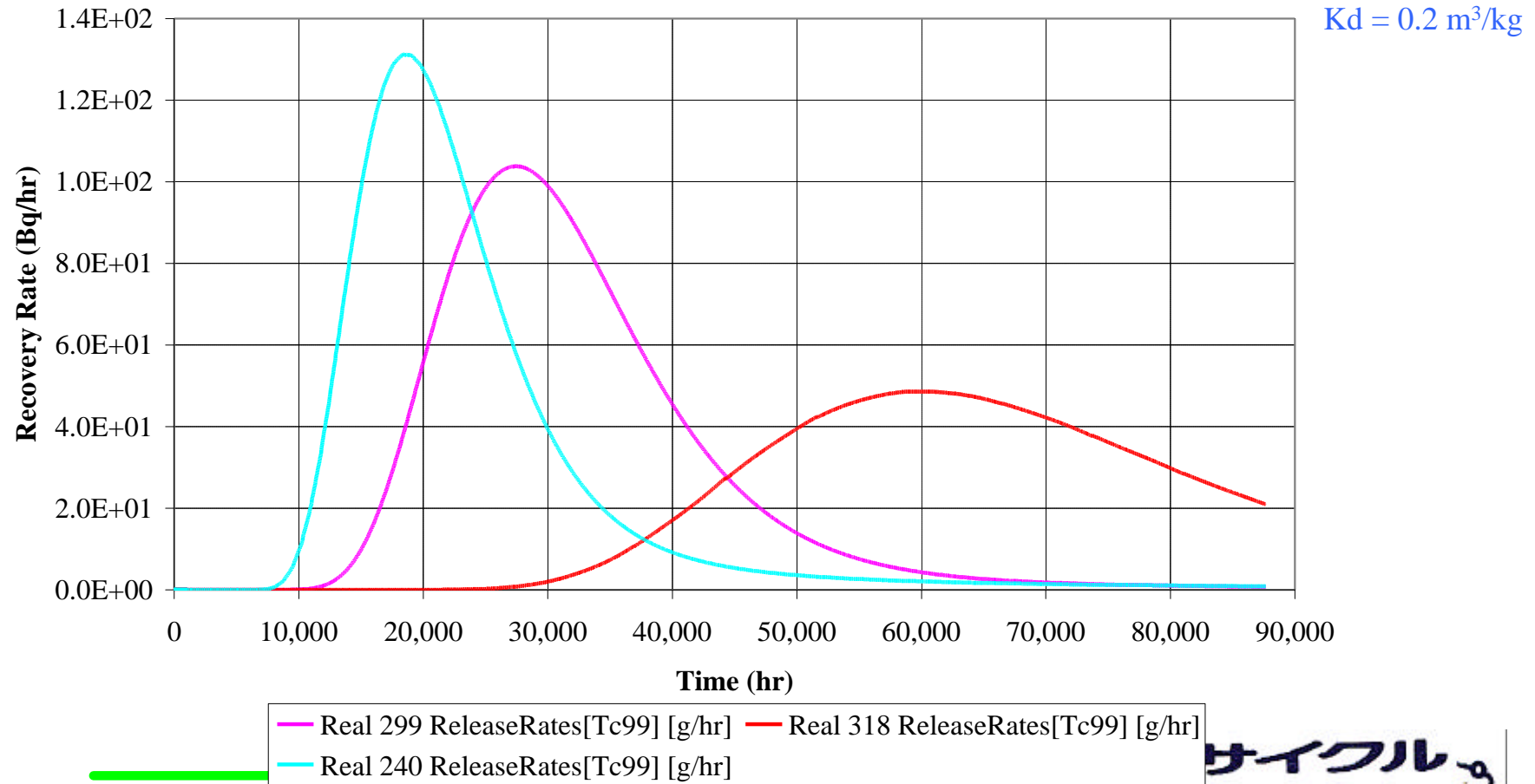


— MeasuredReleaseRate\_Co58 [g/hr] — Real 299 ReleaseRates[Co58] [g/hr]  
— Real 318 ReleaseRates[Co58] [g/hr] — Real 240 ReleaseRates[Co58] [g/hr]



# Tc-99 Breakthrough Realizations 299, 318 & 240

Tc-99 Release Rate



923 1089.H13

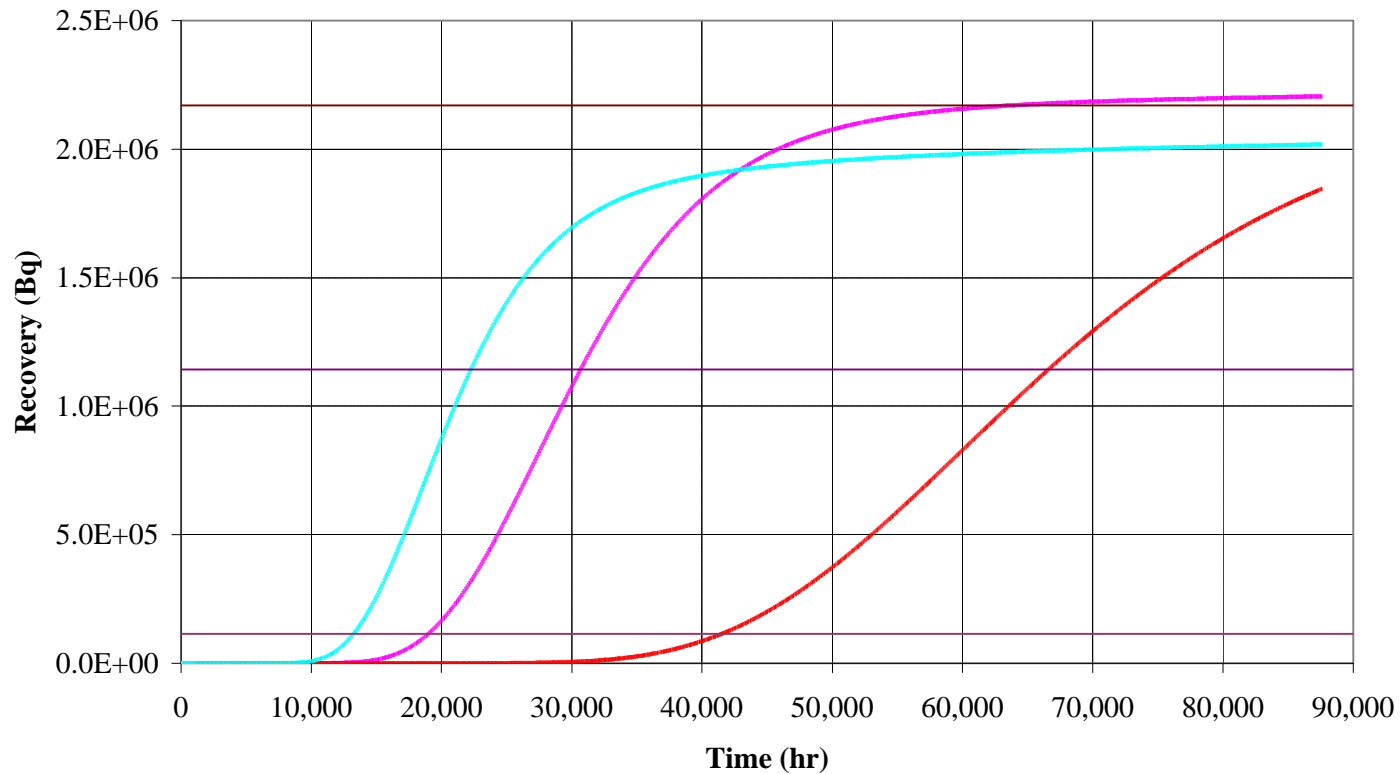




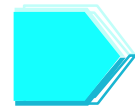
# Tc-99 Breakthrough Realizations 299, 318 & 240

$K_d = 0.2 \text{ m}^3/\text{kg}$

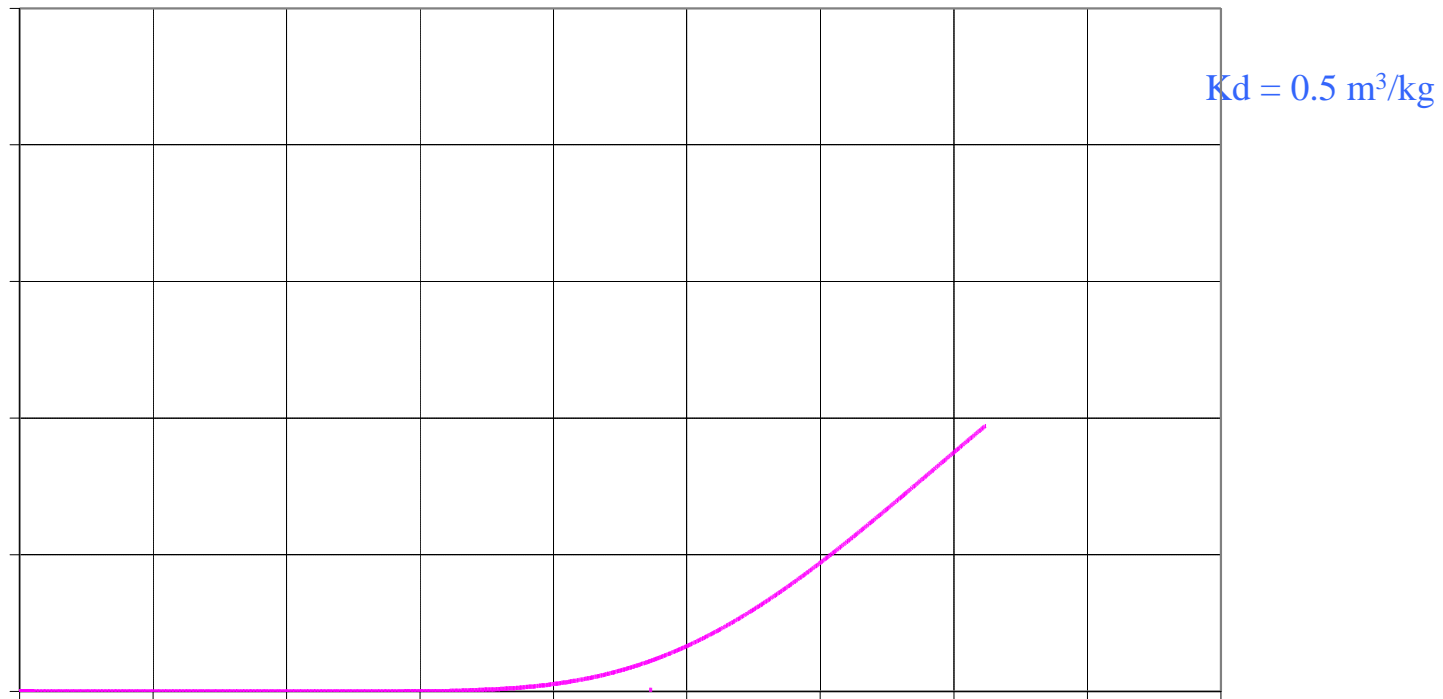
Tc-99 Cumulative Release



— Real 299 MassRelease[Tc99] [g] — Real 318 MassRelease[Tc99] [g] — Real 240 MassRelease[Tc99] [g]



# Am-241 Breakthrough Realizations 299, 318 & 240



## Constraint to Sorbing Tracer Test

- The preceding analyses demonstrates that conservative tracers poorly constrain sorbing tracer transport
- The following analyses take the best fits to the Sr-85 analyses, and using a smaller range of  $K_d$  values, constrain results to sorbing tracer Sr-85

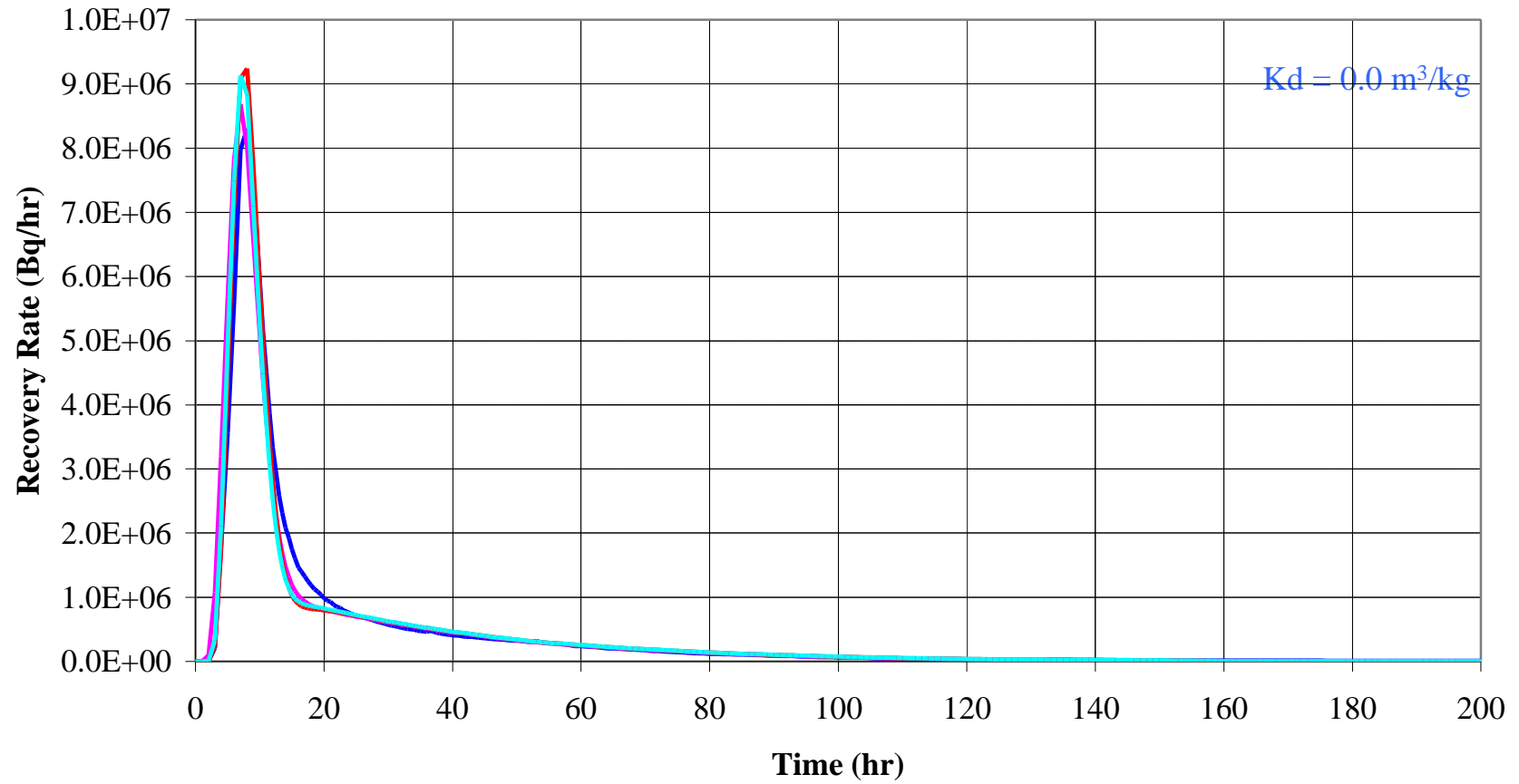
## Refinement for Sorbing Tracers

- The pathway parameters are purely stochastic and improved fits could likely be obtained with additional refinement
- Co-58 still not well constrained
- Fits to the conservative tracers were still generally good - the Volume Ratio range defined earlier provides constraint for these tracers
- Demonstrate the ability of sorbing tracers to constrain transport properties

## Refinement for Sorbing Tracers

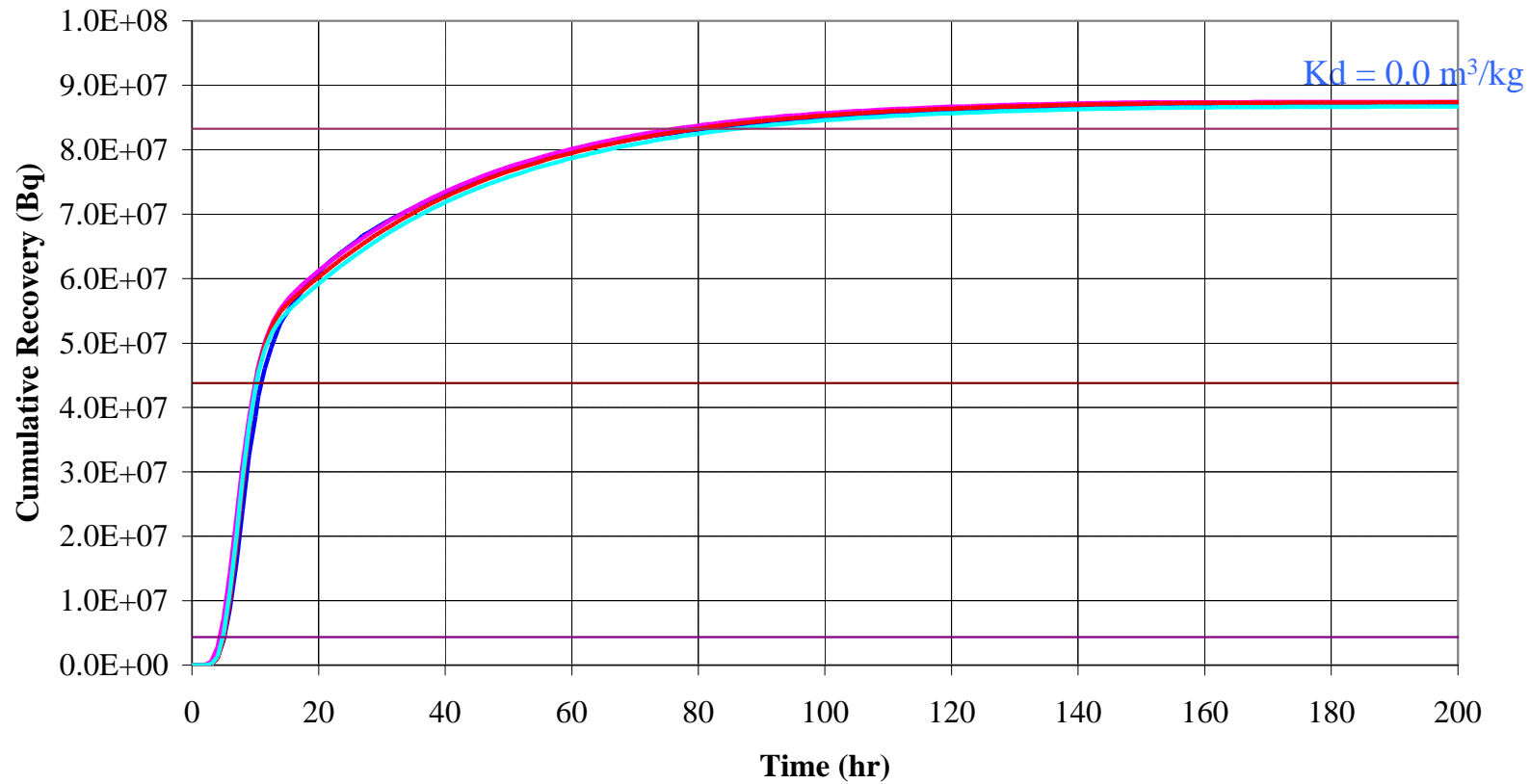
- The fit for Realization 385 was better than the fits that were obtained from the next best realizations - 299 & 241

# HTO Breakthrough Realizations 385, 299 & 241

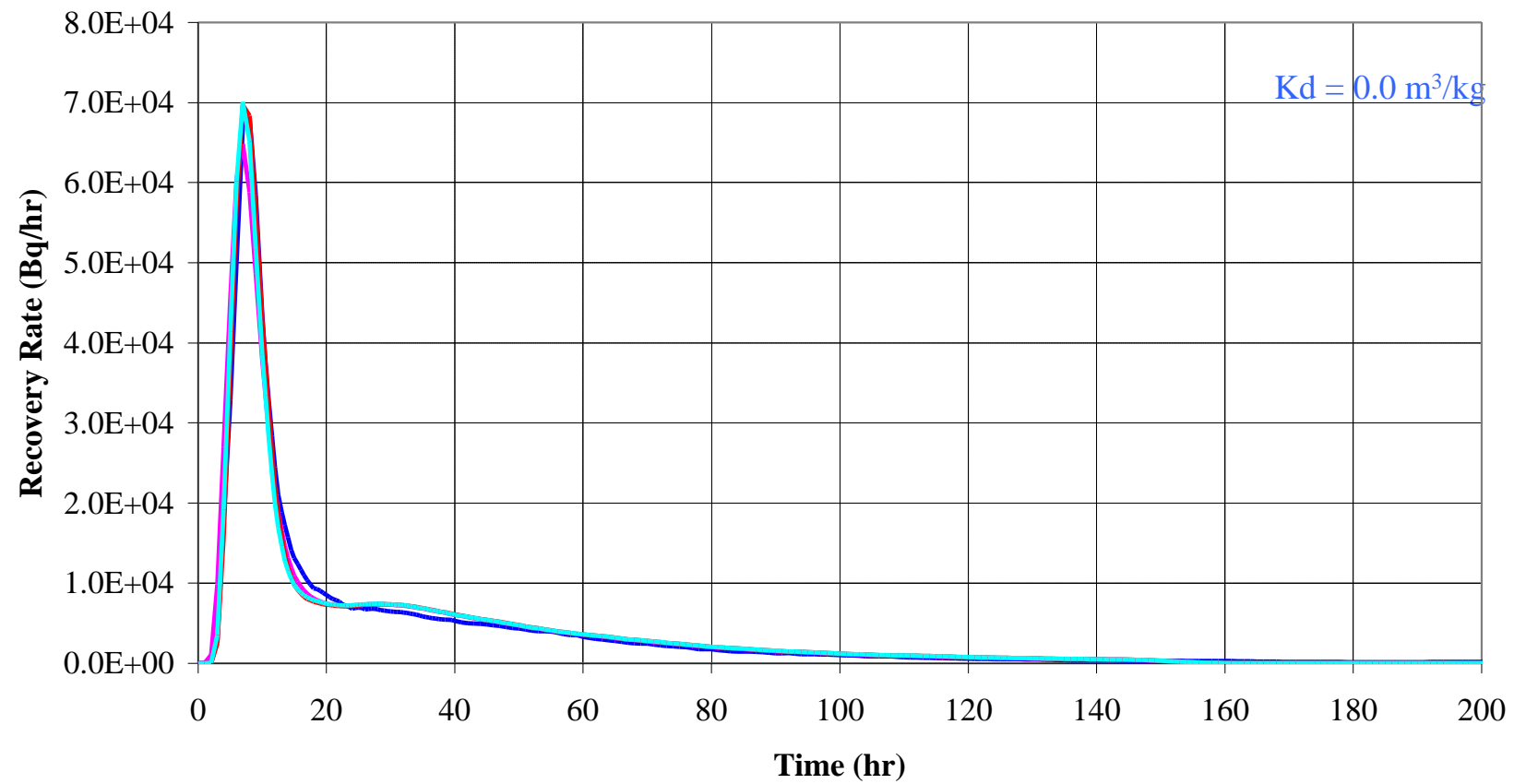


— MeasuredReleaseRate\_HTO [g/hr] — Real 385 ReleaseRates[HTO] [g/hr]  
— Real 299 ReleaseRates[HTO] [g/hr] — Real 241 ReleaseRates[HTO] [g/hr]

# HTO Breakthrough Realizations 385, 299 & 241

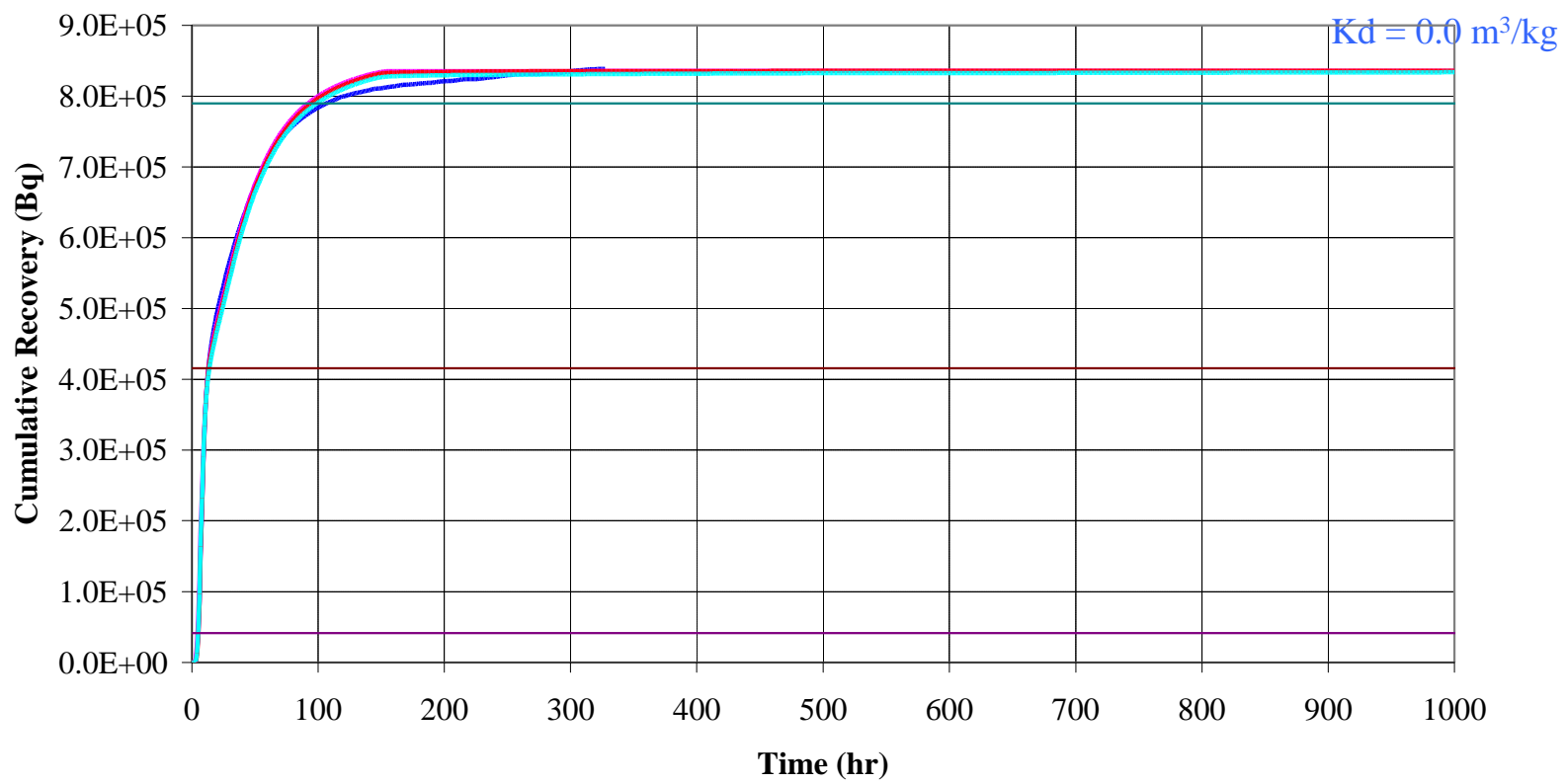


# I-131 Breakthrough Realizations 385, 299 & 241

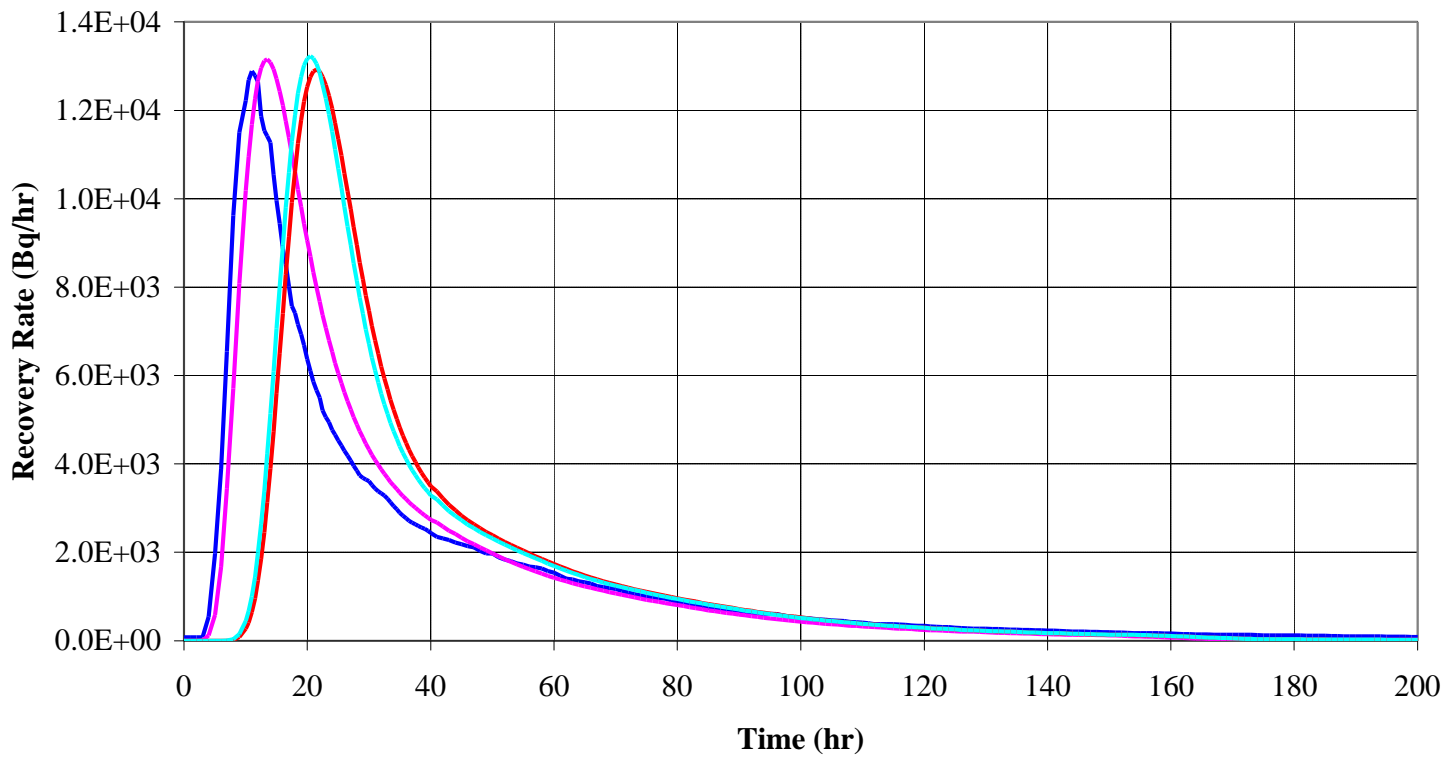




# I-131 Breakthrough Realizations 385, 299 & 241

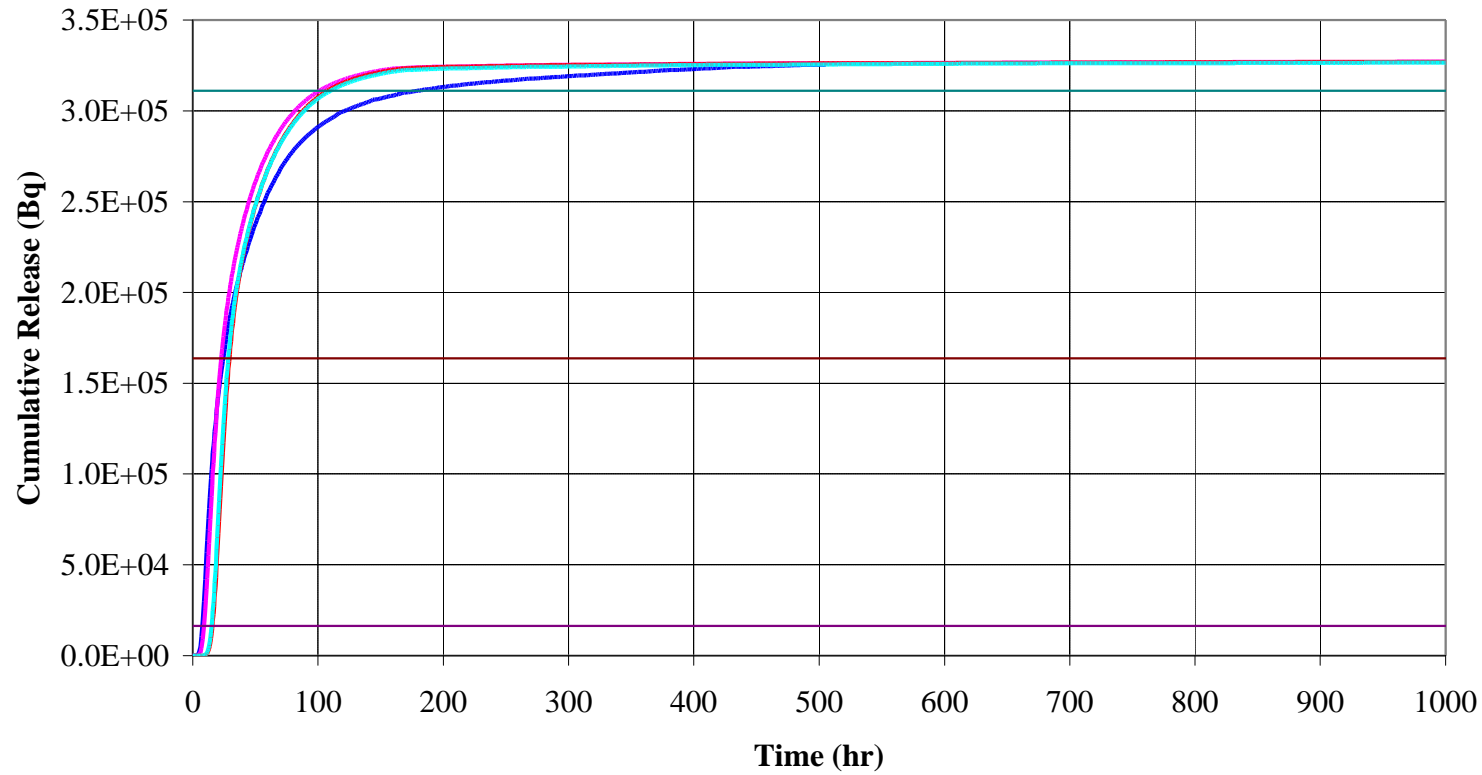


# Sr-85 Breakthrough Realizations 385, 299 & 241



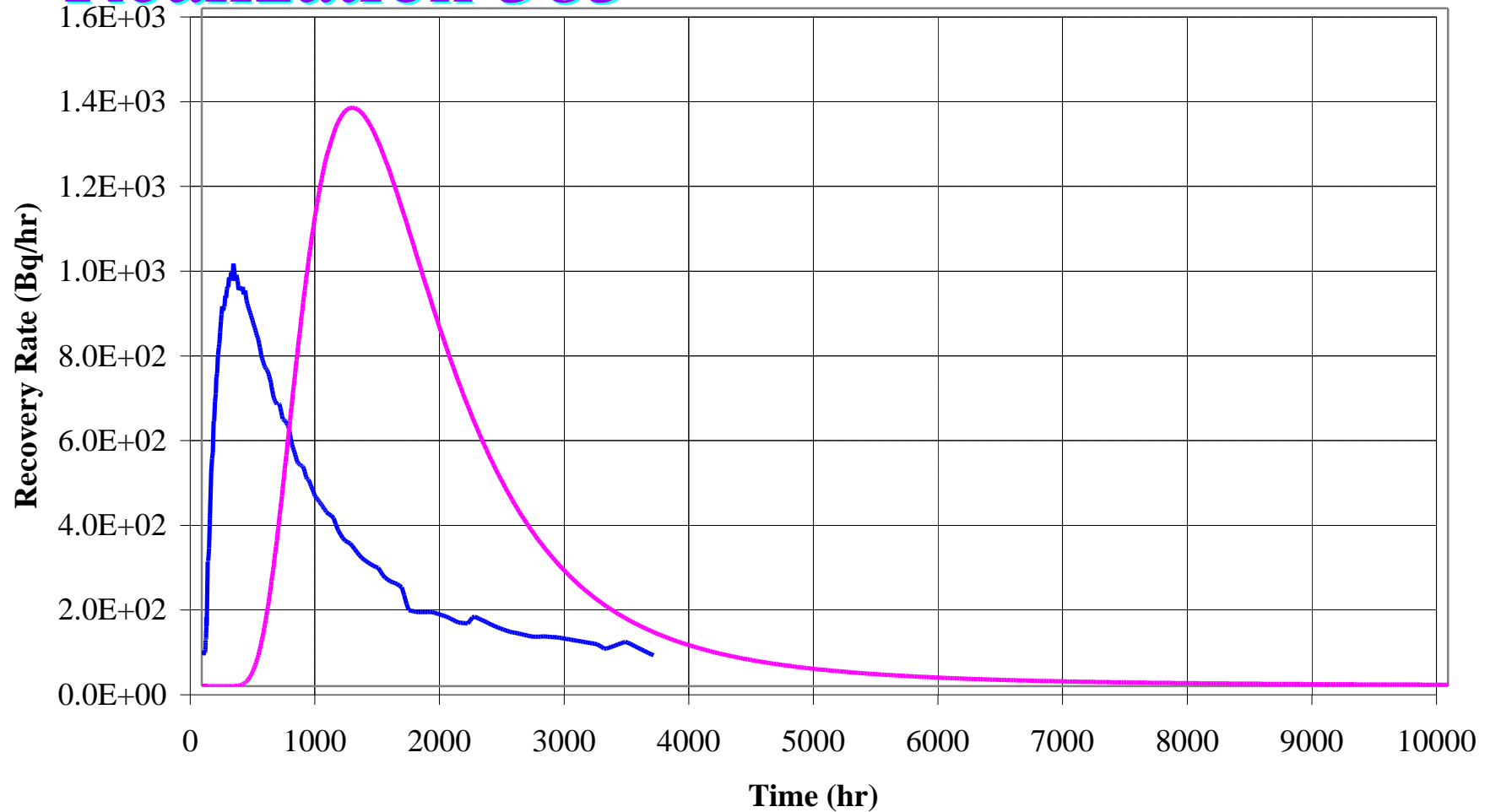
— MeasuredReleaseRate\_Sr85 [g/hr]   
 — Real 385 ReleaseRates[Sr85] [g/hr]  
— Real 299 ReleaseRates[Sr85] [g/hr]   
 — Real 241 ReleaseRates[Sr85] [g/hr]

# Sr-85 Breakthrough Realizations 385, 299 & 241

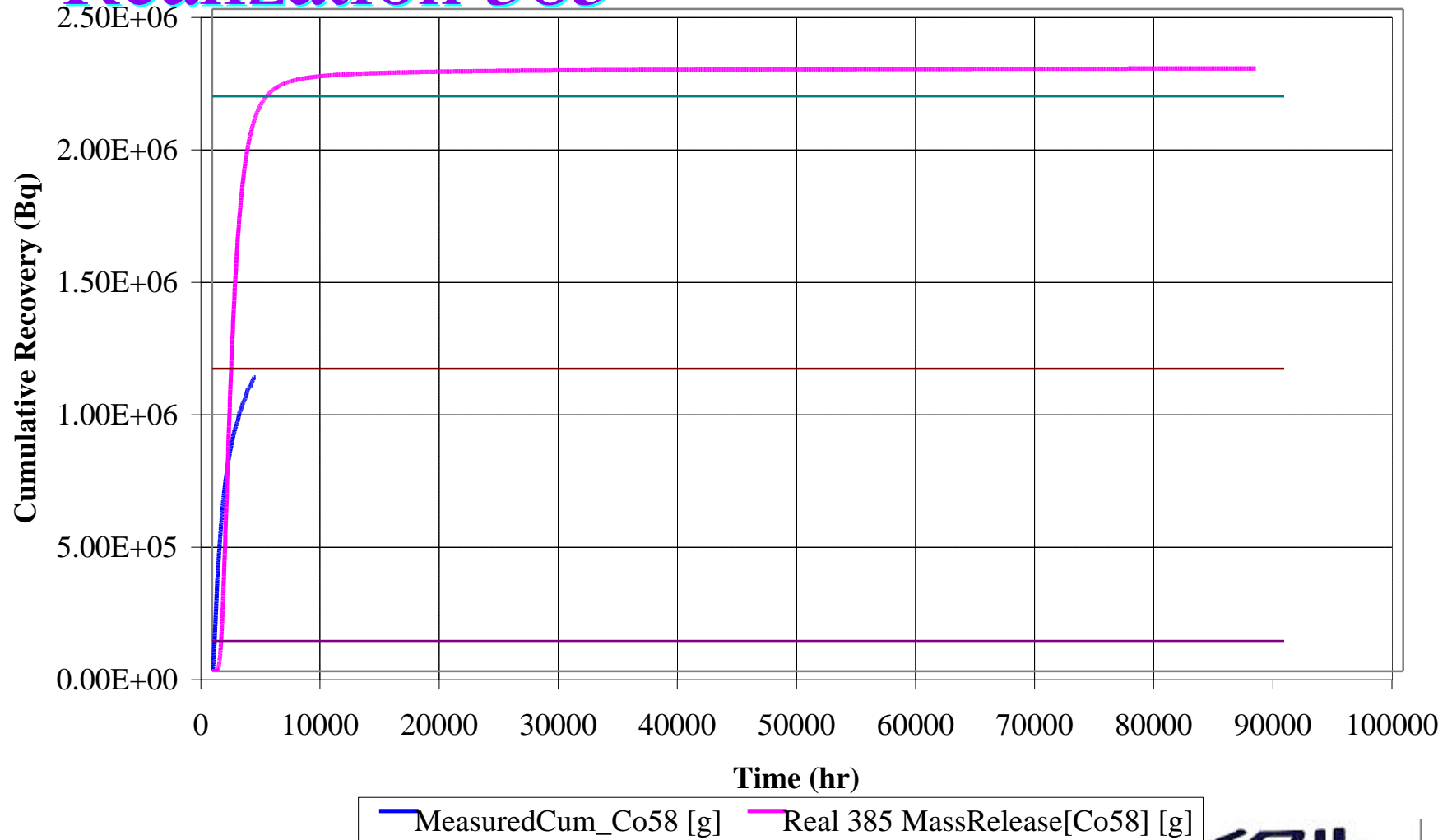


— MeasuredCum\_Sr85 [g]      — MassRelease.MassRelease[Sr85] [g]  
— MassRelease.MassRelease[Sr85] [g]      — Real 241 MassRelease[Sr85] [g]

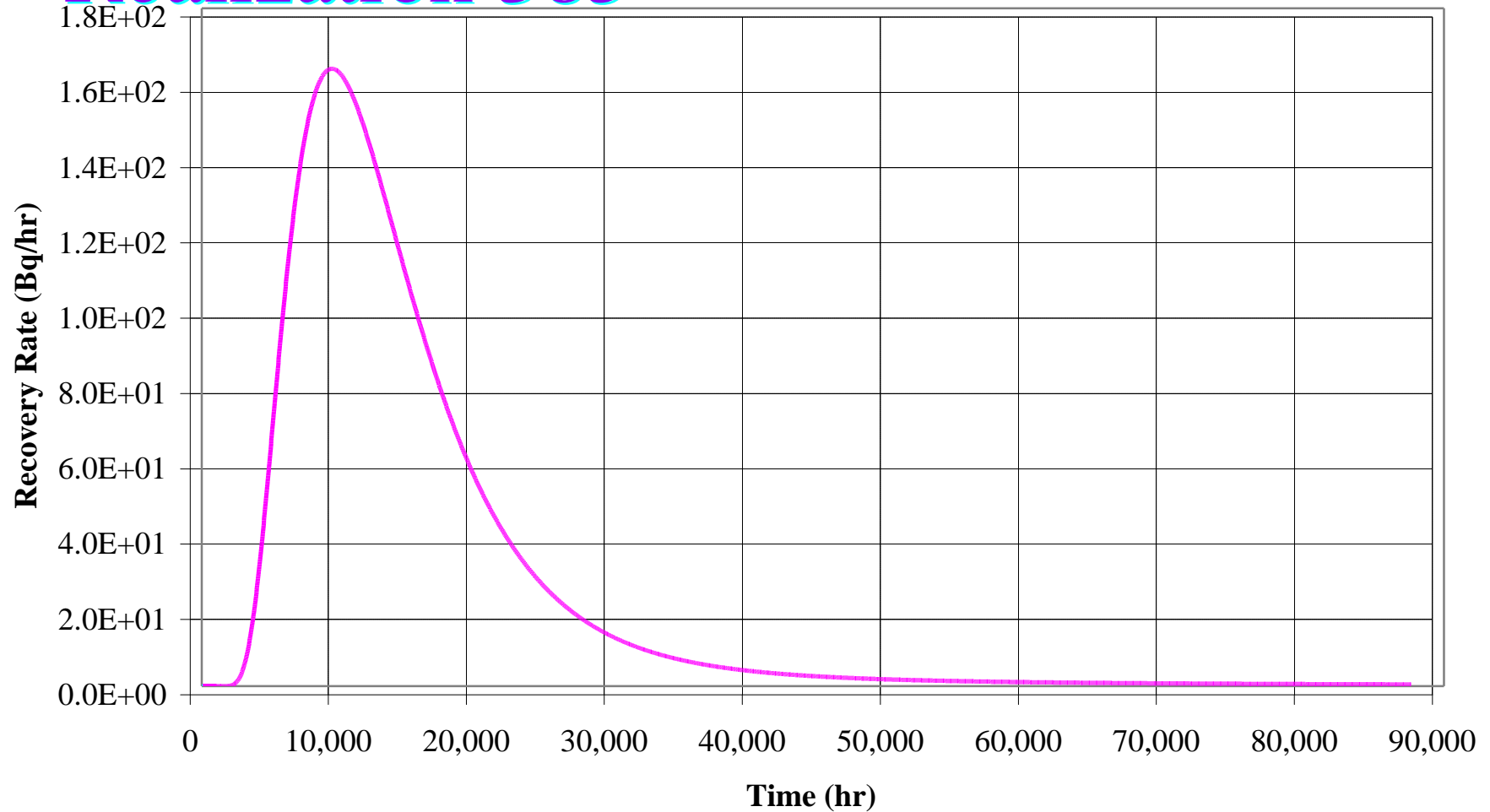
# Co-58 Breakthrough Realization 385



# Co-58 Breakthrough Realization 385

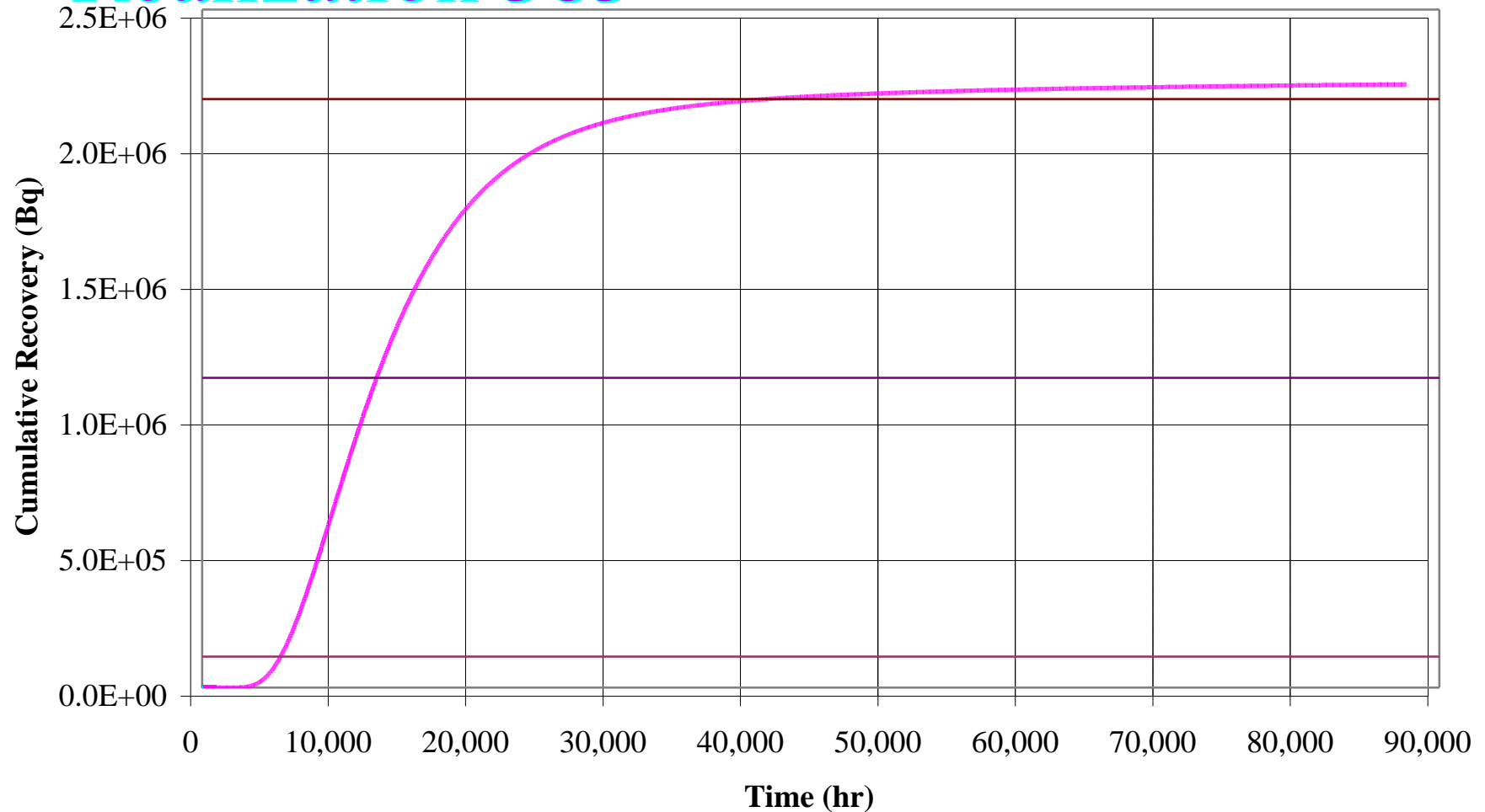


# Tc-99 Breakthrough Realization 385



Real 385 ReleaseRates[Tc99] [g/hr]

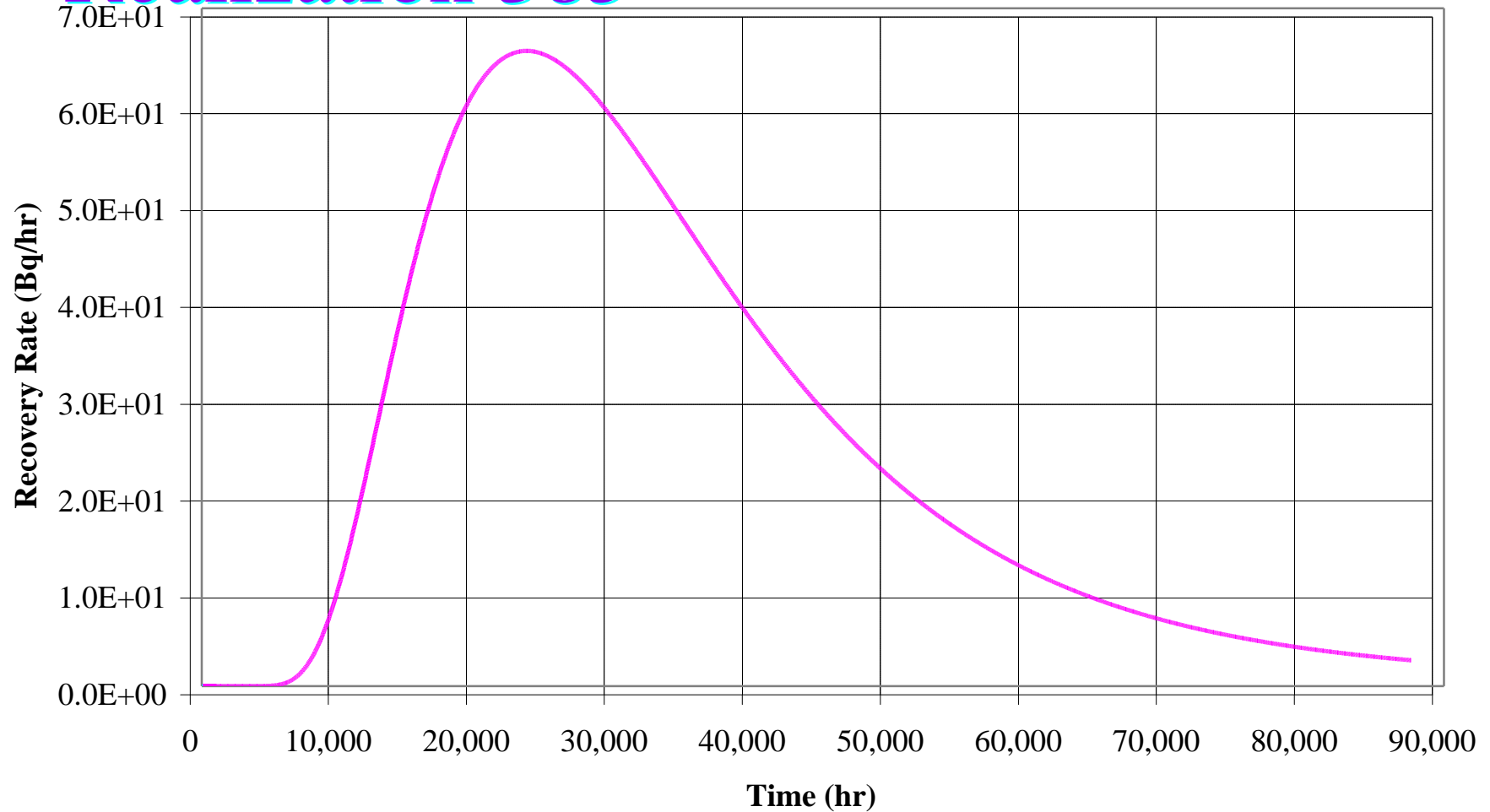
# Tc-99 Breakthrough Realization 385



923 1089.H13

Real 385 MassRelease[Tc99] [g]

# Am-241 Breakthrough Realization 385

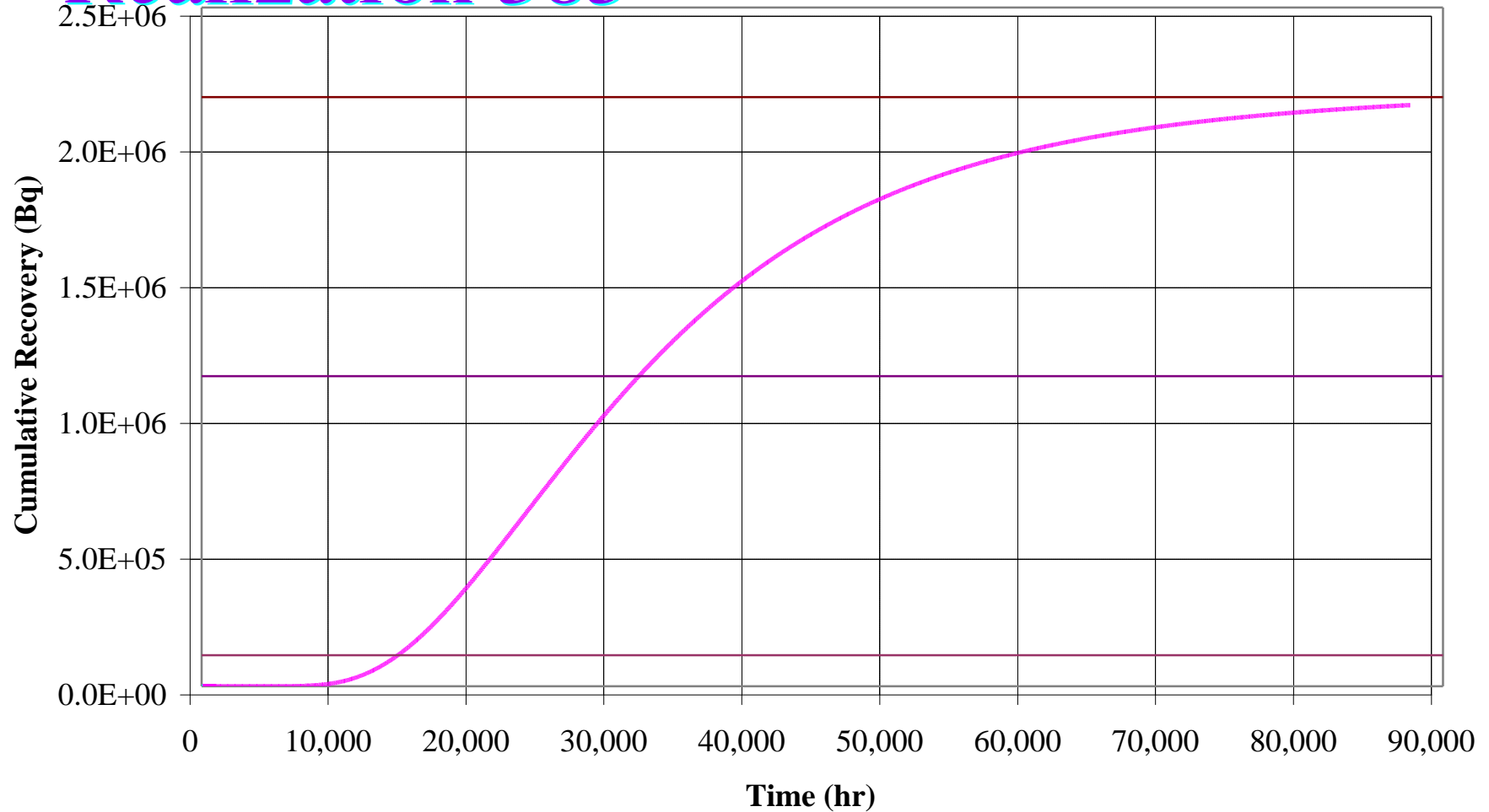


Real 385 ReleaseRates[Am241] [g/hr]

923 1089.H13



# Am-241 Breakthrough Realization 385



Real 385 MassRelease[Am241] [g]

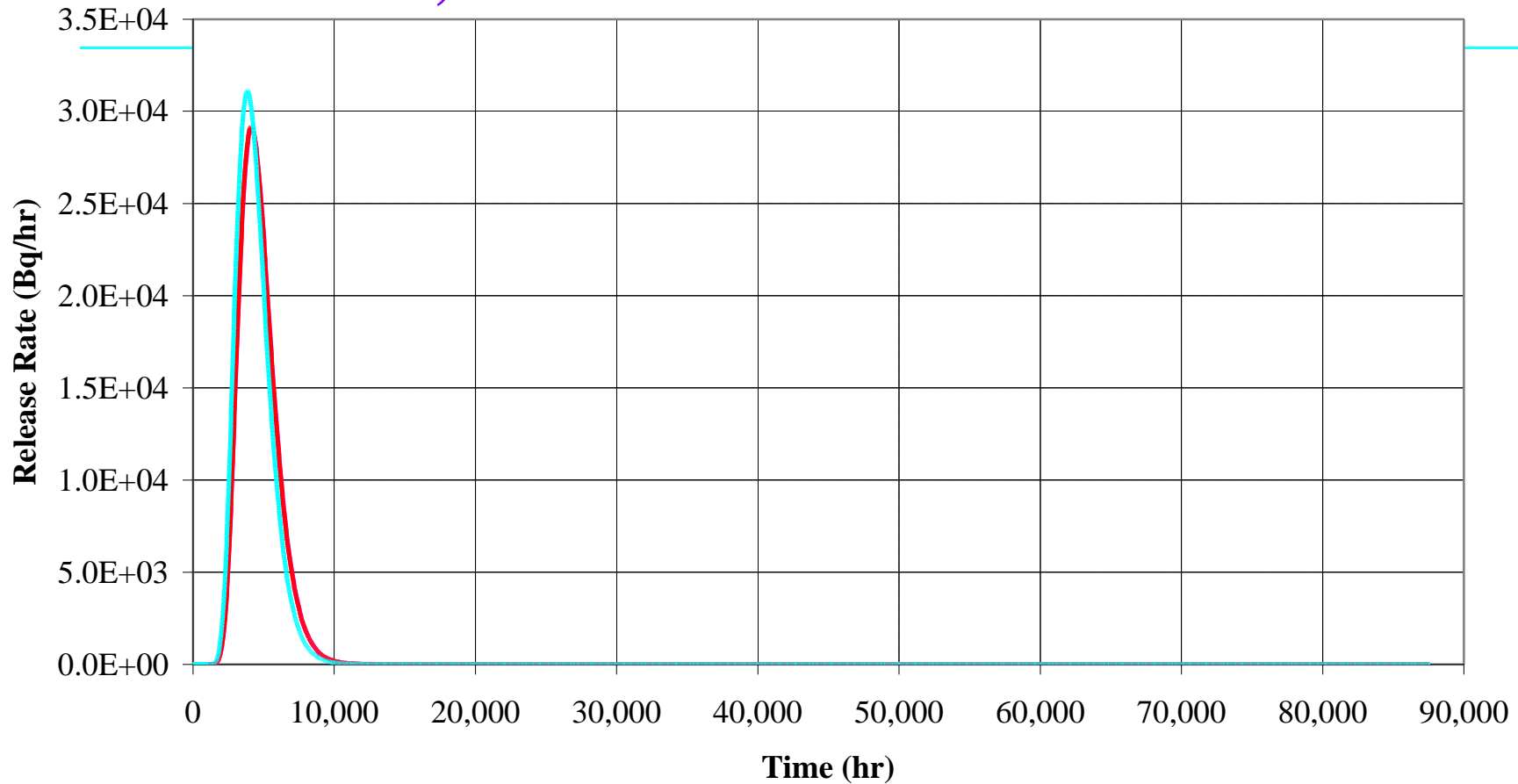
923 1089.H13

## Task 6B

- Task 6B investigates the effect of running the 6A pathway using a PA timescale
- The three realizations (299, 318 & 240) were rerun using a travel time 1000 times smaller than that used for the original Task 6A simulations - all other properties are identical
- The effect on the release curves, and particularly the differences between the 3 realizations was observed.



# HTO Breakthrough at PA Time Scales Real 299, 318 & 240



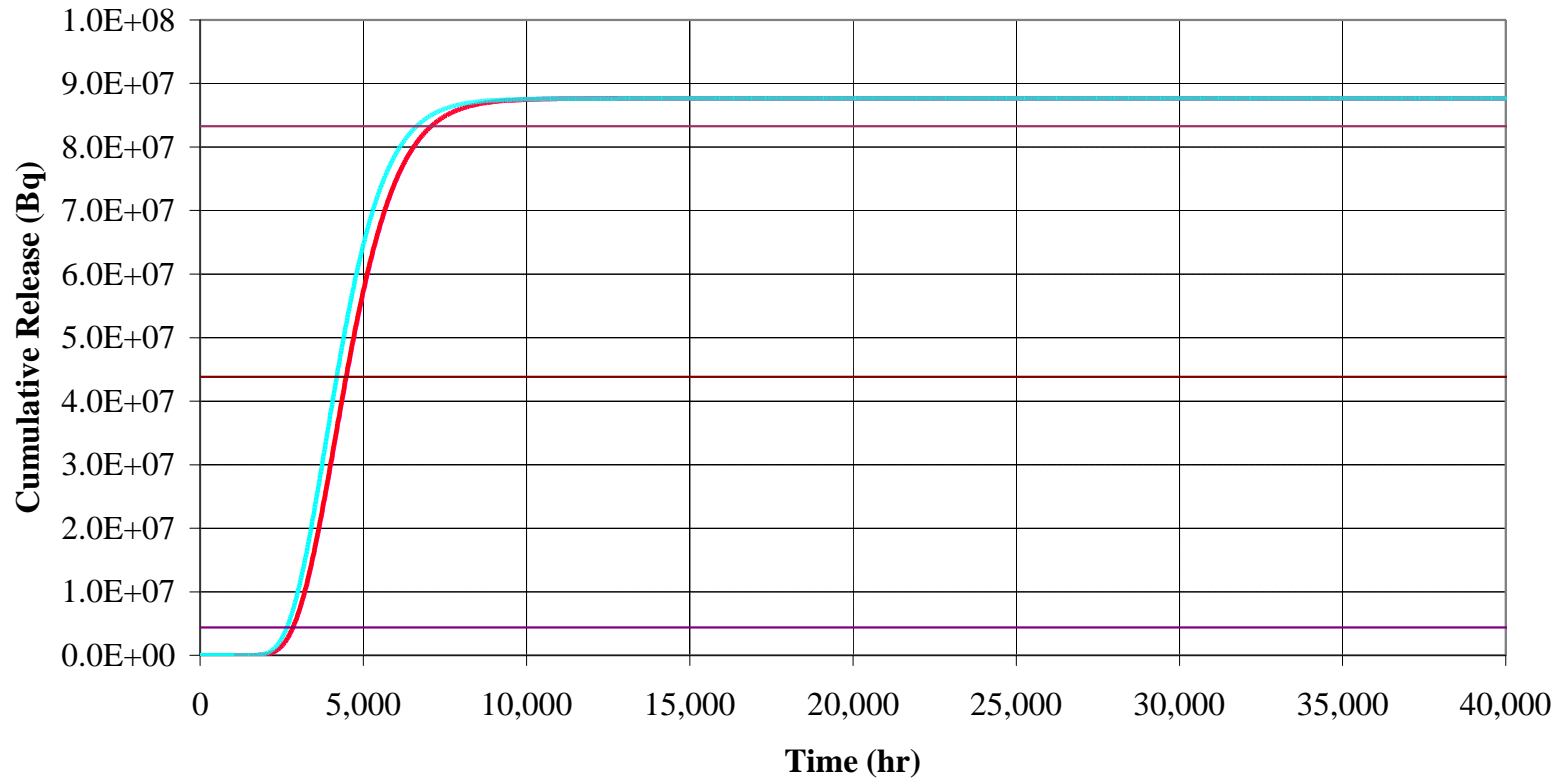
923 1089.H13

Real 299 ReleaseRates[HTO] [g/hr]    Real 318 ReleaseRates[HTO] [g/hr]  
Real 240 ReleaseRates[HTO] [g/hr]

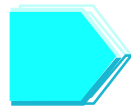
フル  
機構



# HTO Breakthrough at PA Time Scales Real 299, 318 & 240

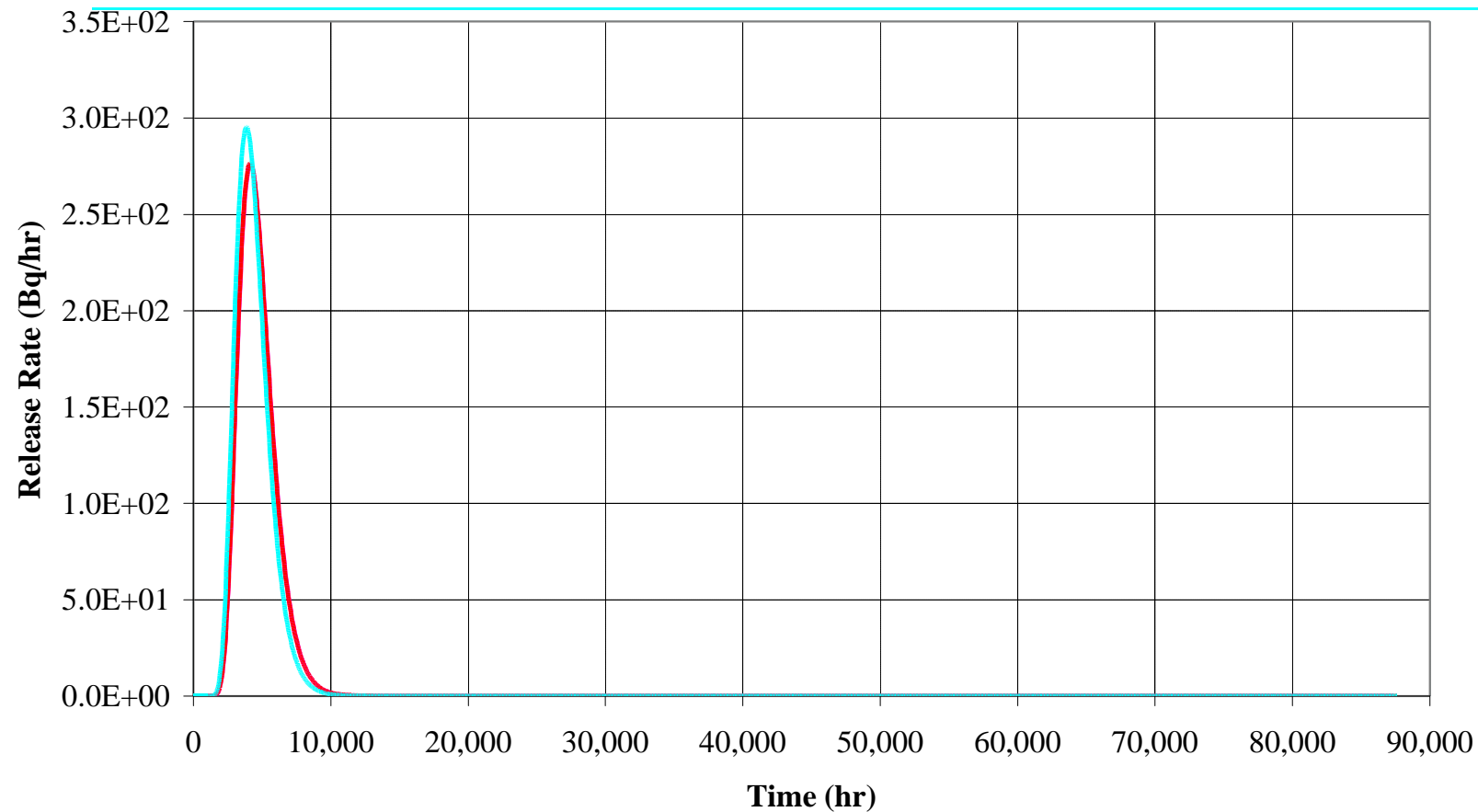


— Real 299 MassRelease[HTO] [g] — Real 318 MassRelease[HTO] [g] — Real 240 MassRelease[HTO] [g]



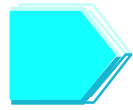
# I-131 Breakthrough at PA Time Scales Real 299, 318 & 240

I-131 Release Rate



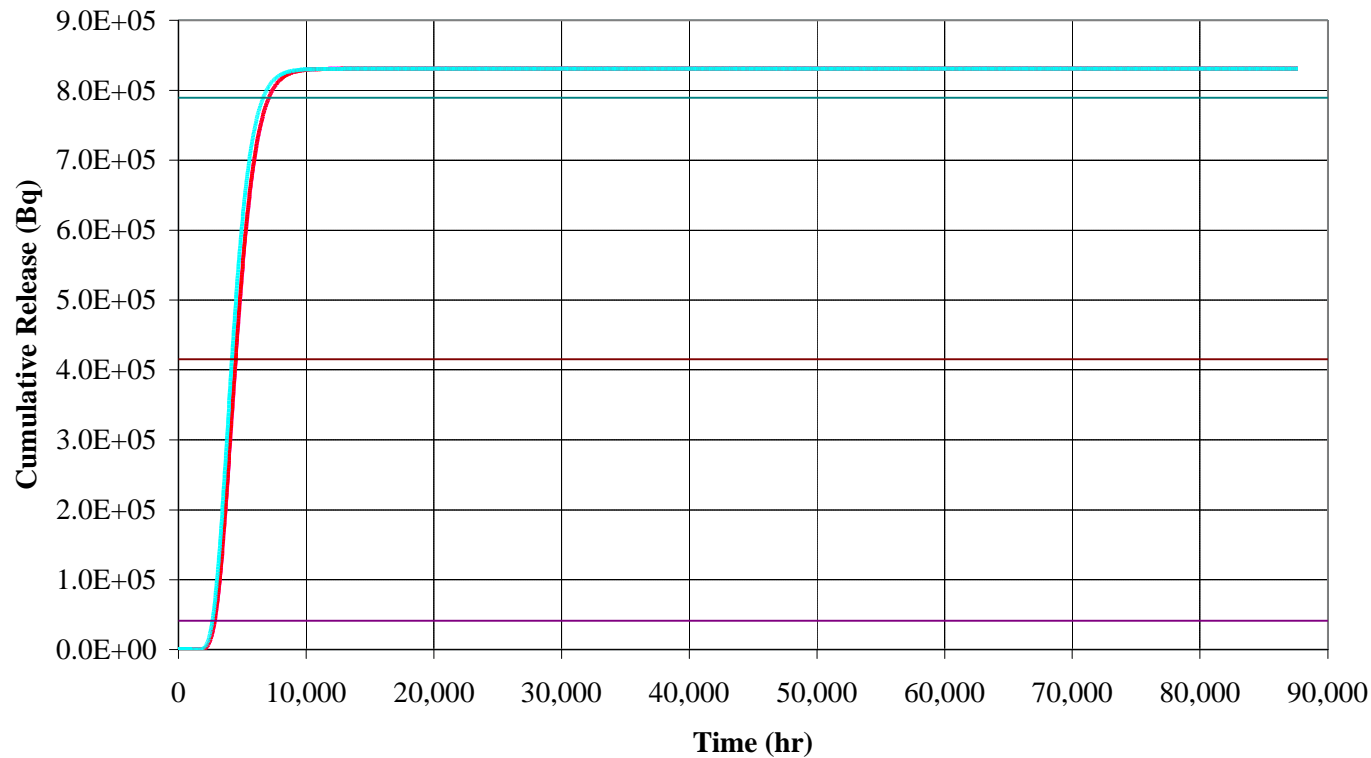
Real 299 ReleaseRates[I131] [g/hr]    Real 318 ReleaseRates[I131] [g/hr]  
Real 240 ReleaseRates[I131] [g/hr]





# I-131 Breakthrough at PA Time Scales Real 299, 318 & 240

I-131 Cumulative Release

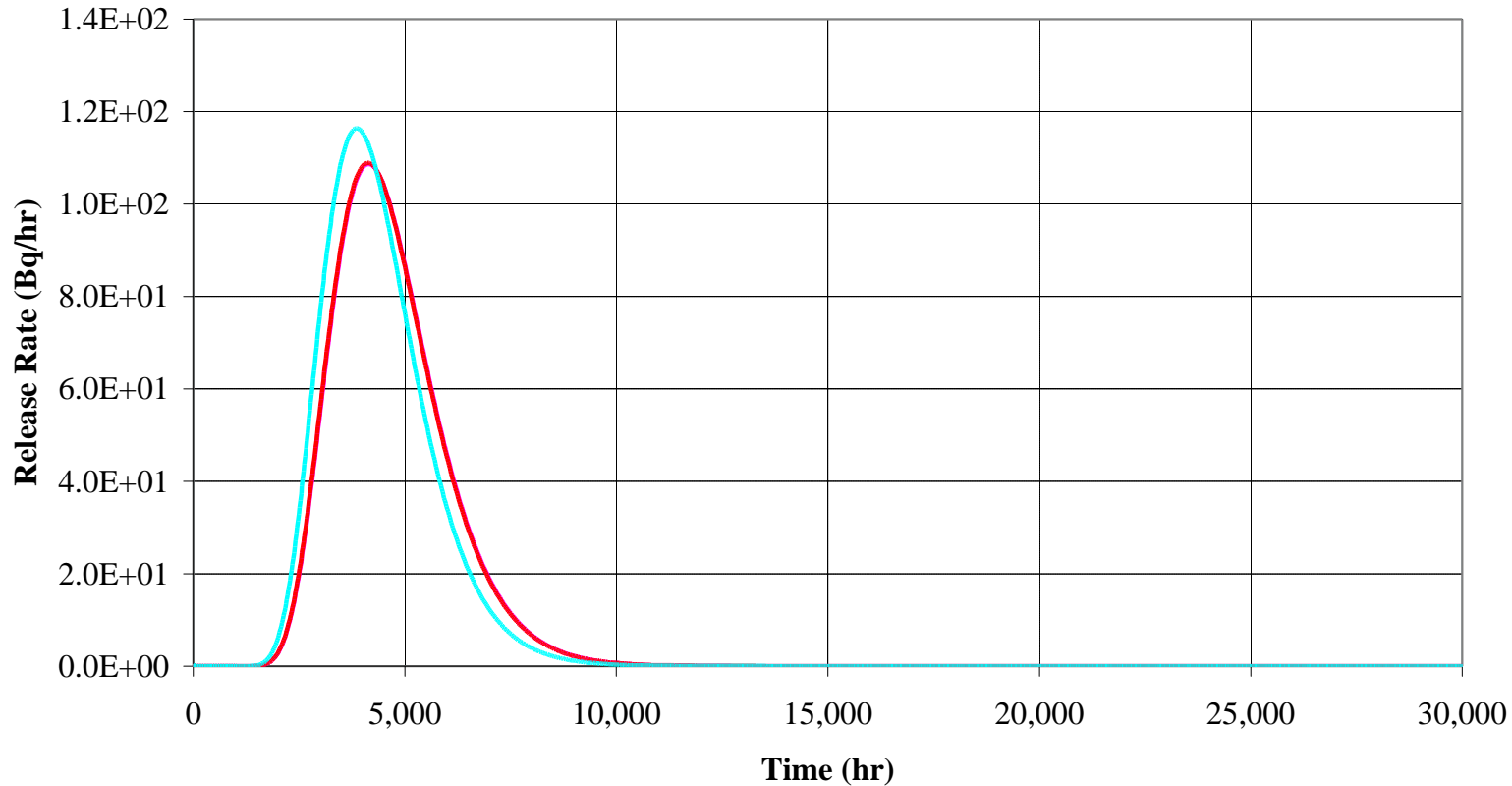


— Real 299 MassRelease[I131] [g] — Real 318 MassRelease[I131] [g] — Real 240 MassRelease[I131] [g]



# Sr-85 Breakthrough at PA Time Scales Real 299, 318 & 240

Sr-85 Release Rate

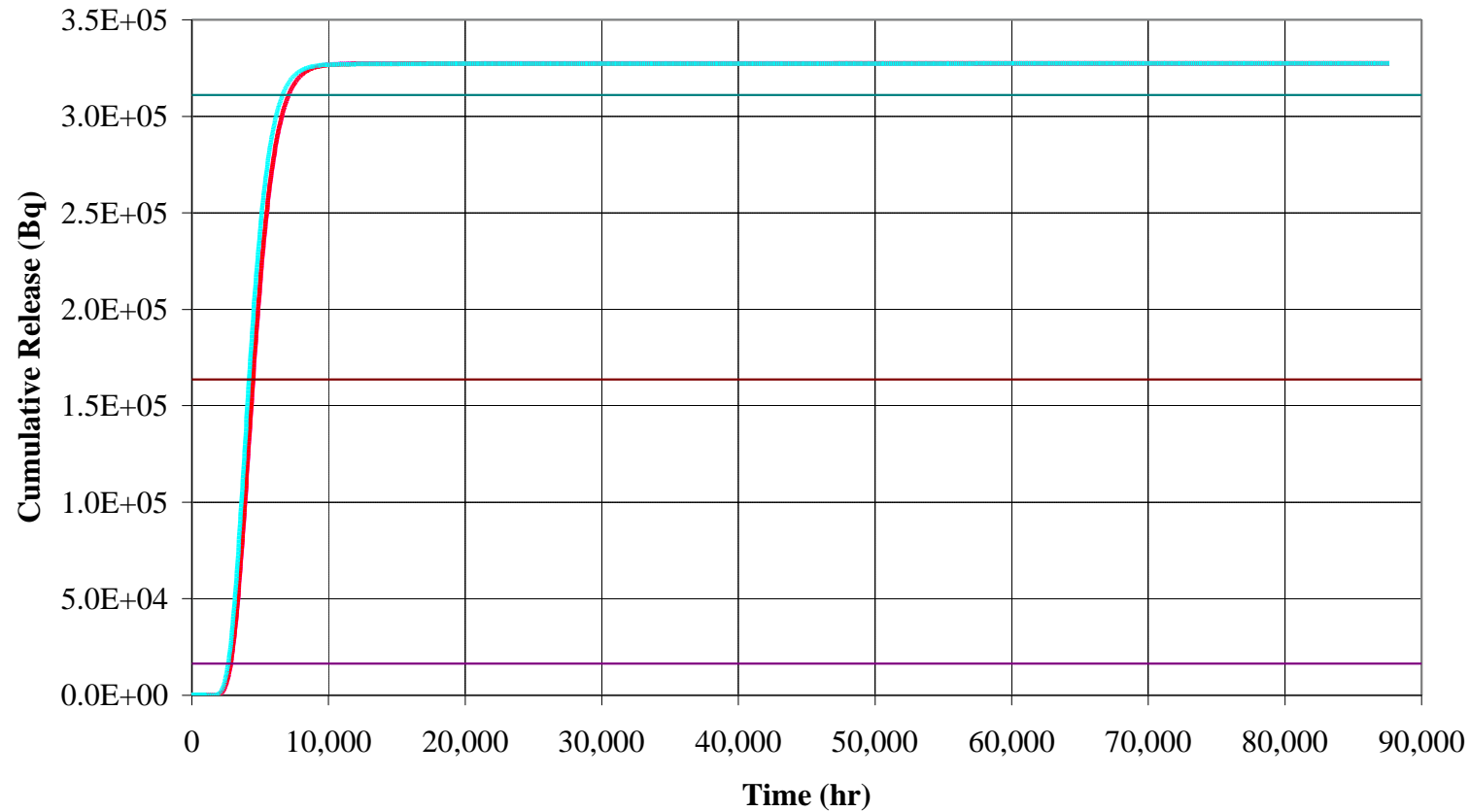


Real 299 ReleaseRate[Sr85] [g/hr] Real 318 ReleaseRate[Sr85] [g/hr]  
Real 240 .ReleaseRate[Sr85] [g/hr]



# Sr-85 Breakthrough at PA Time Scales Real 299, 318 & 240

Sr-85 Cumulative Release



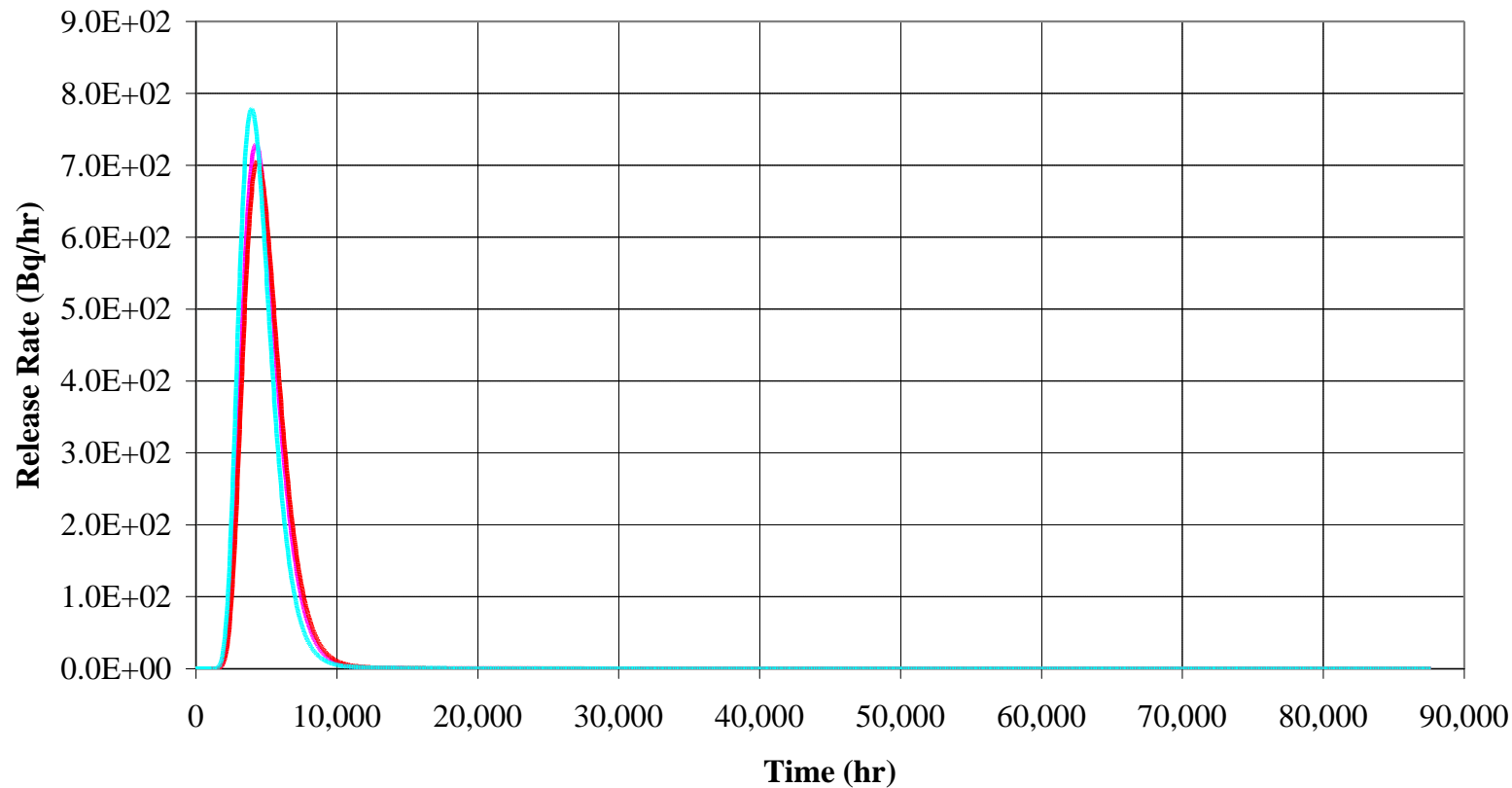
Real 299 MassRelease[Sr85] [g] Real 318 MassRelease[Sr85] [g] Real 240 MassRelease[Sr85] [g]

923 1089.H13

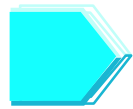




# Co-58 Breakthrough at PA Time Scales Real 299, 318 & 240

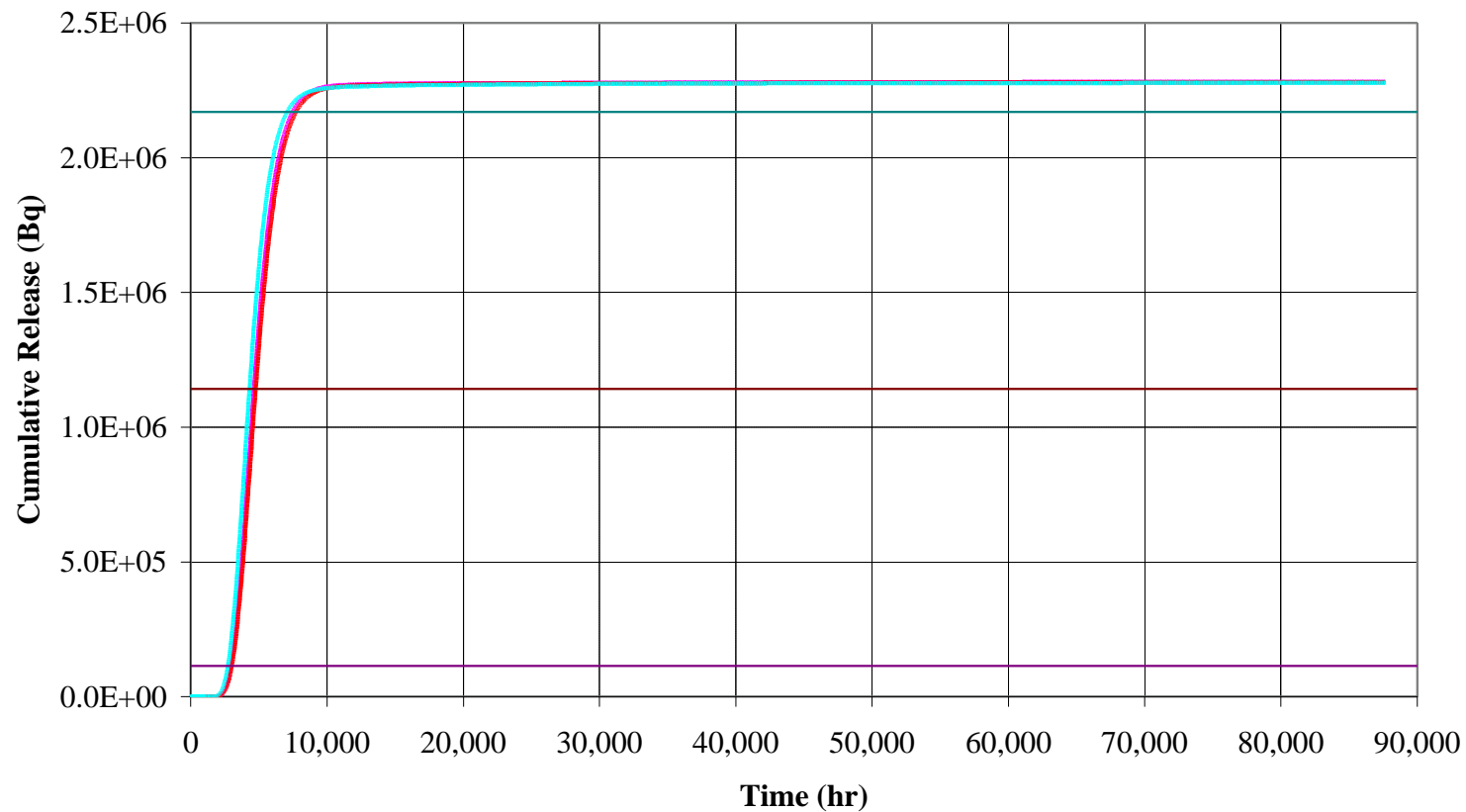


Real 299 ReleaseRates[Co58] [g/hr]    Real 318 ReleaseRates[Co58] [g/hr]  
Real 240 ReleaseRates[Co58] [g/hr]

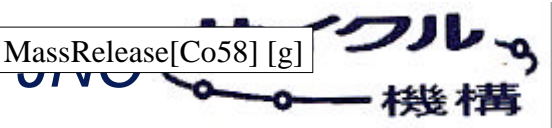


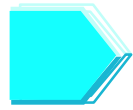
# Co-58 Breakthrough at PA Time Scales Real 299, 318 & 240

Co-58 Cumulative Release



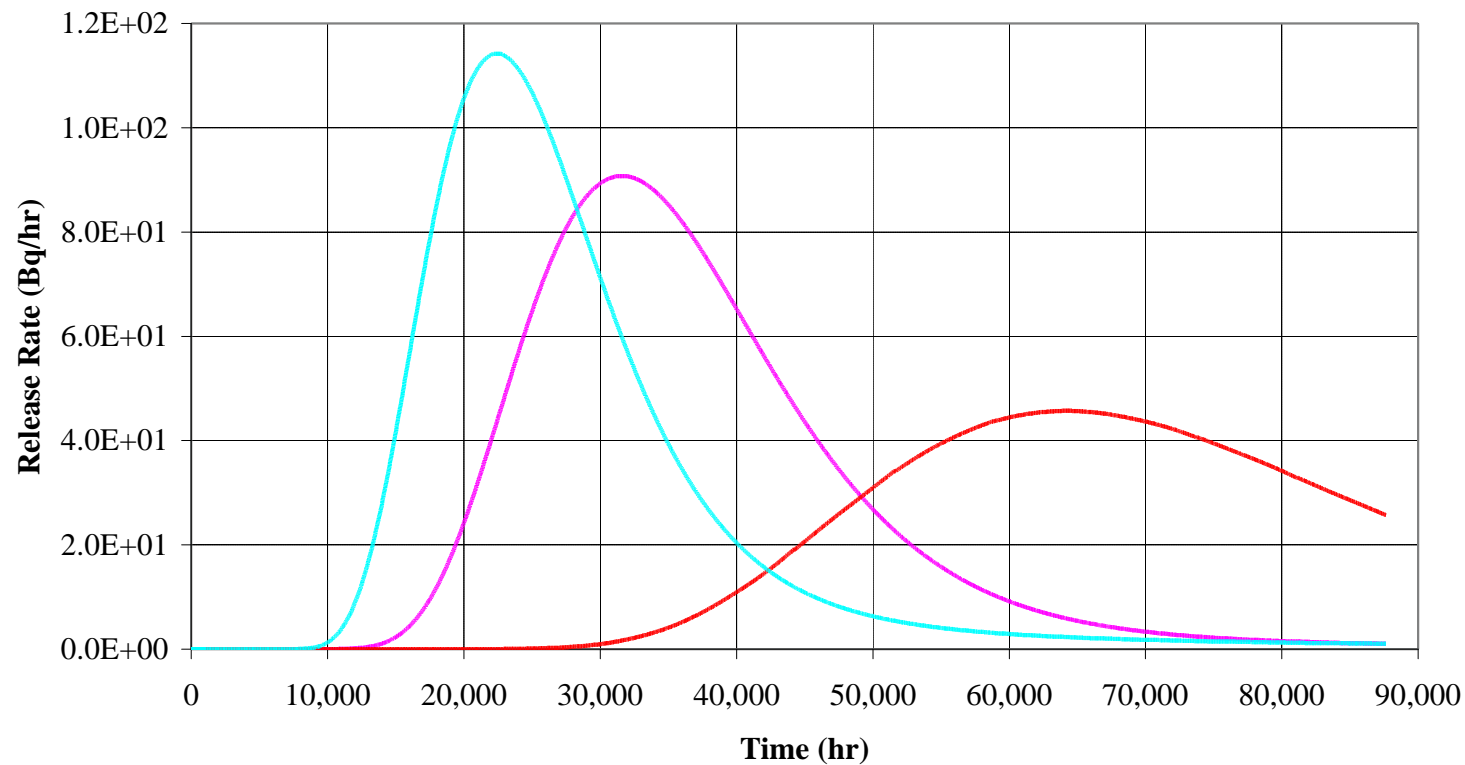
— Real 299 MassRelease[Co58] [g] — Real 318 MassRelease[Co58] [g] — Real 240 MassRelease[Co58] [g]



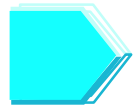


# Tc-99 Breakthrough at PA Time Scales Real 299, 318 & 240

Tc-99 Release Rate

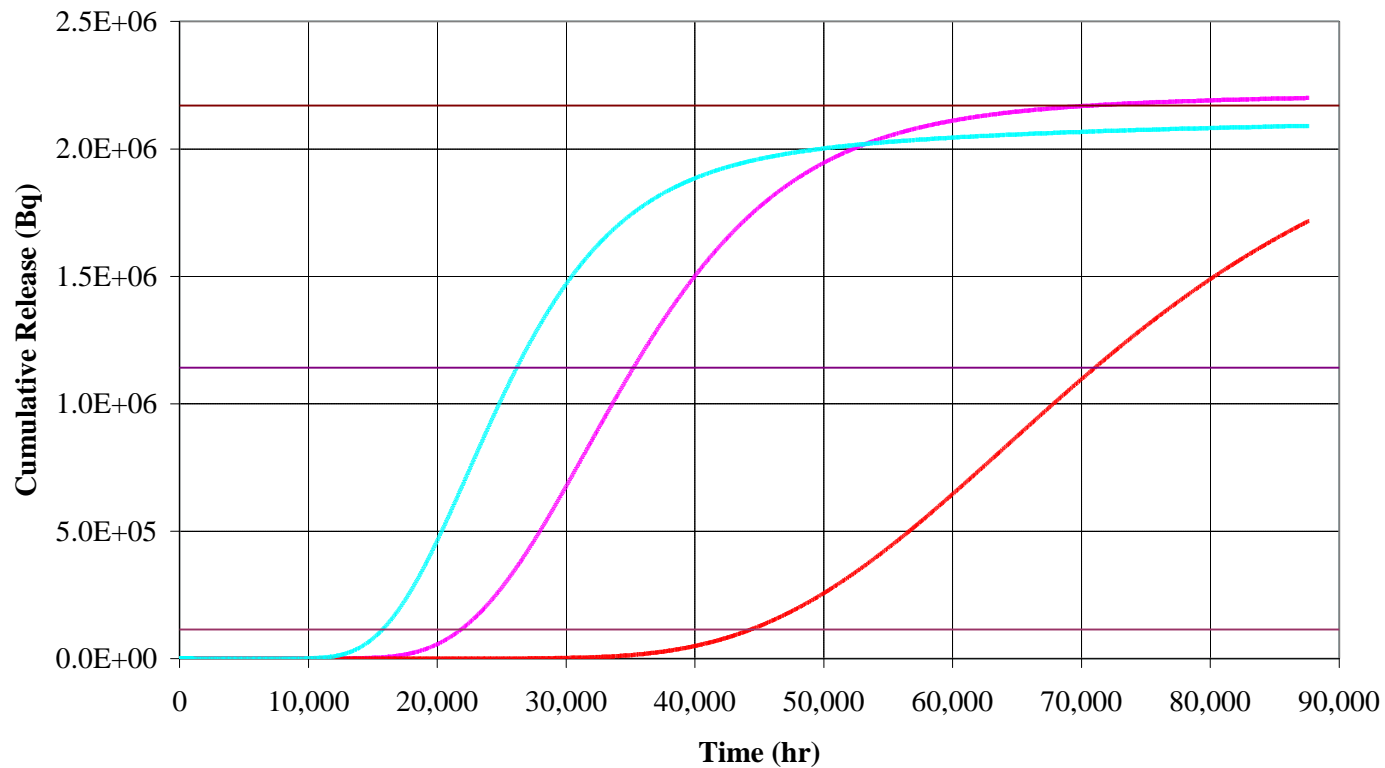


Real 299 .ReleaseRates[Tc99] [g/hr] Real 318 .ReleaseRates[Tc99] [g/hr]  
Real 240 ReleaseRates[Tc99] [g/hr]



# Tc-99 Breakthrough at PA Time Scales Real 299, 318 & 240

Tc-99 Cumulative Release

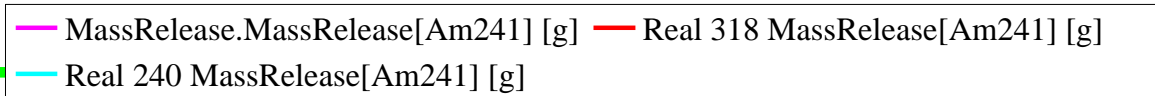
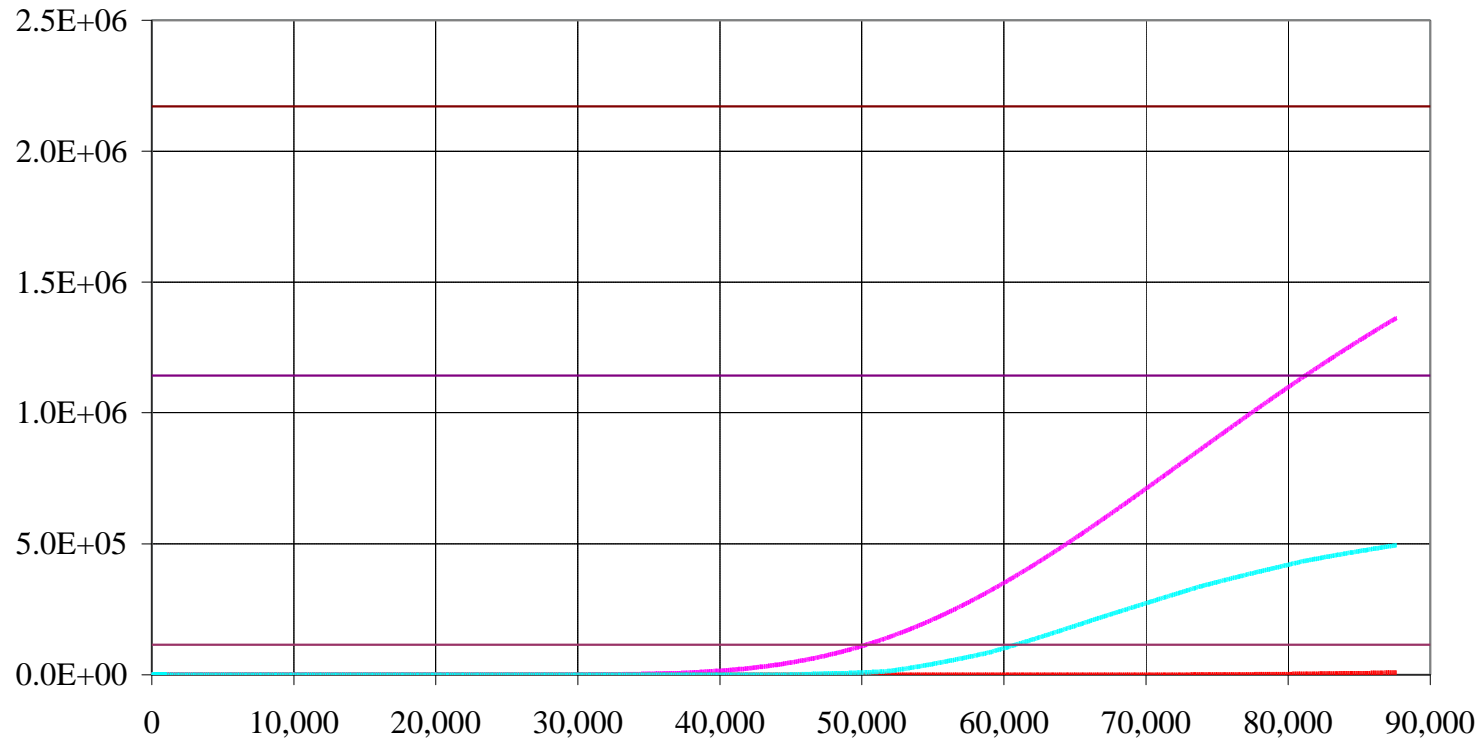


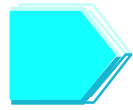
— Real 299 MassRelease[Tc99] [g] — Real 318 MassRelease[Tc99] [g] — Real 240 MassRelease[Tc99] [g]



# Am-241 Breakthrough at PA Time Scales Real 299, 318 & 240

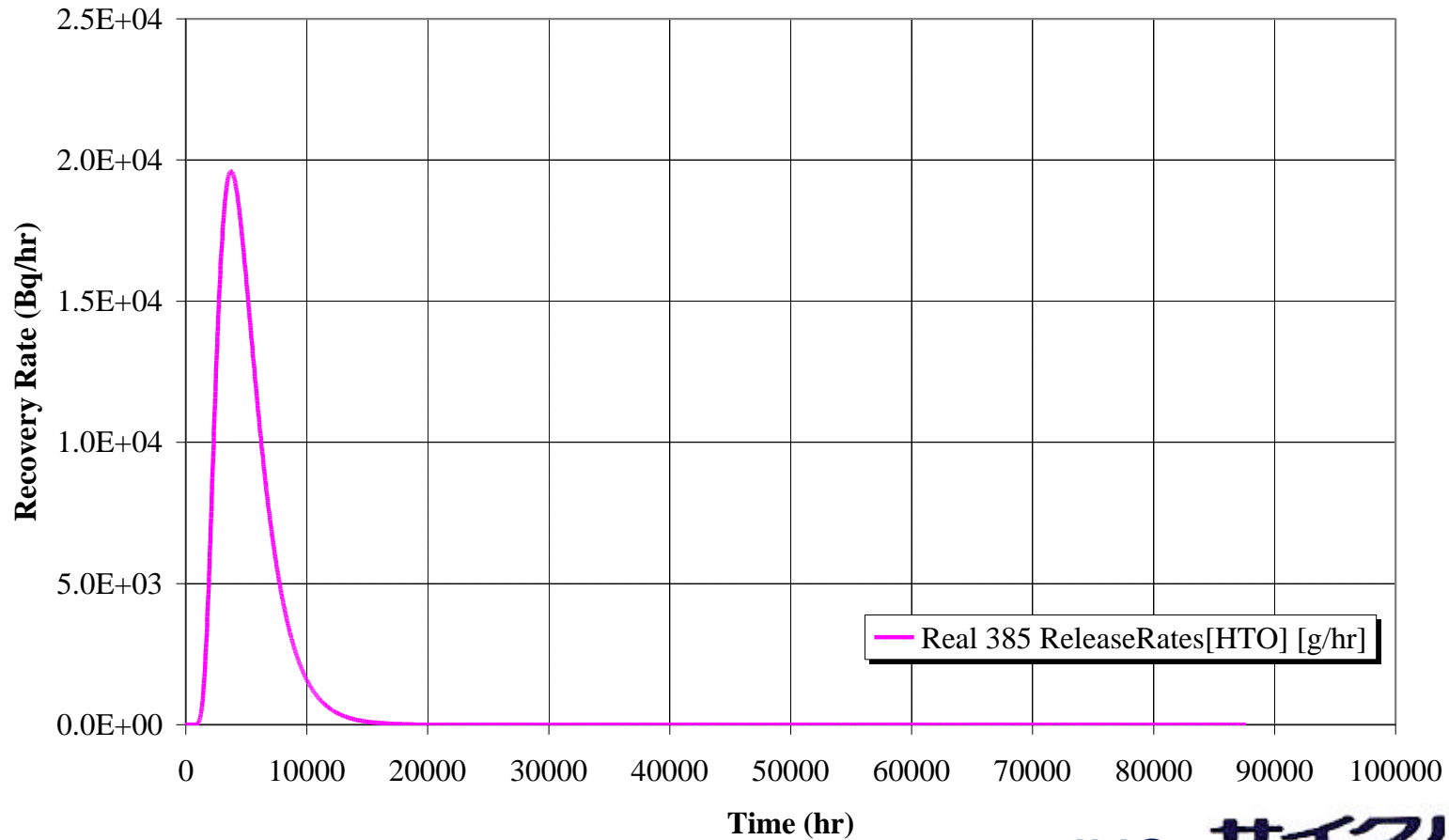
Am-241 Cumulative Release

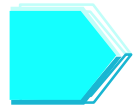




# HTO Breakthrough at PA Time Scales Real 385

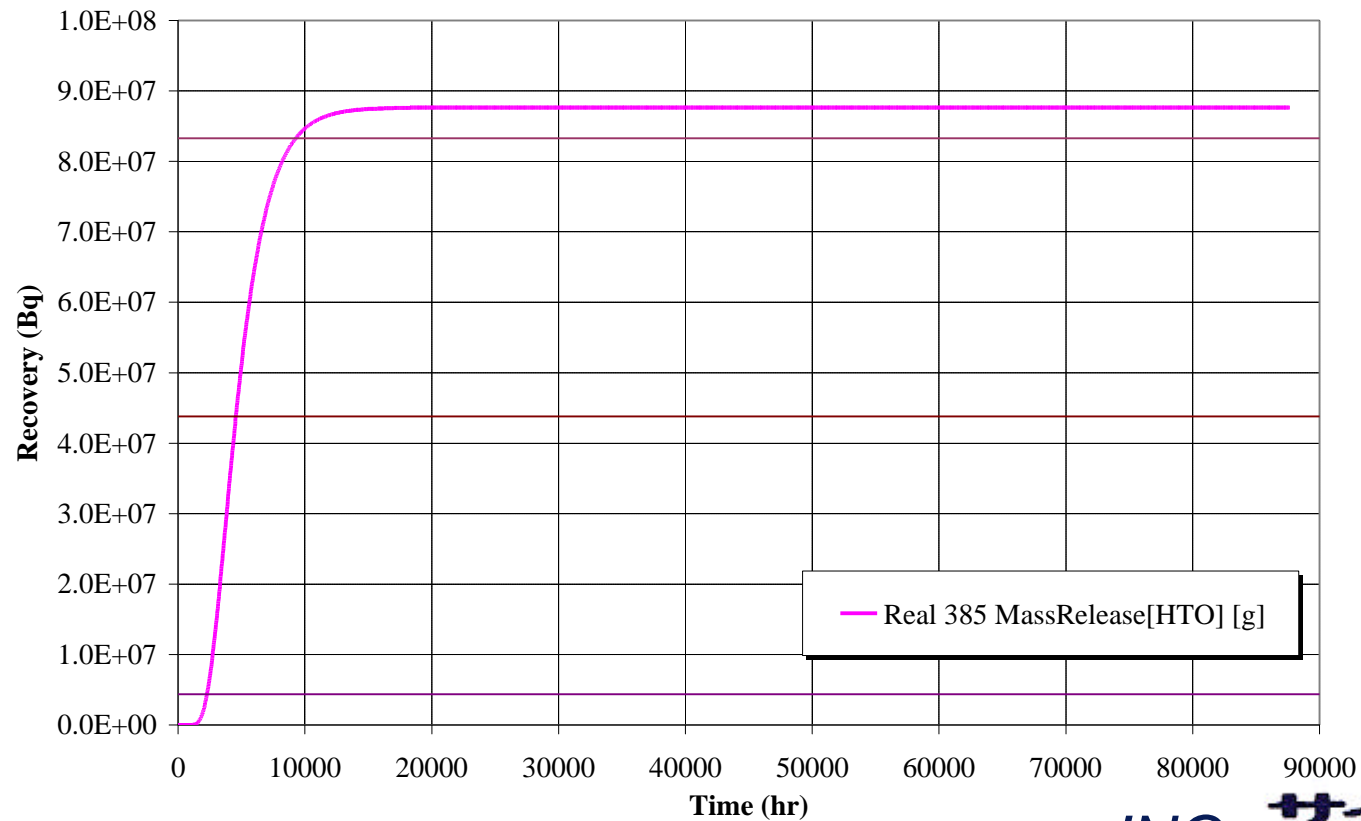
HTO Release Rate





# HTO Breakthrough at PA Time Scales Real 385

HTO Cumulative Release

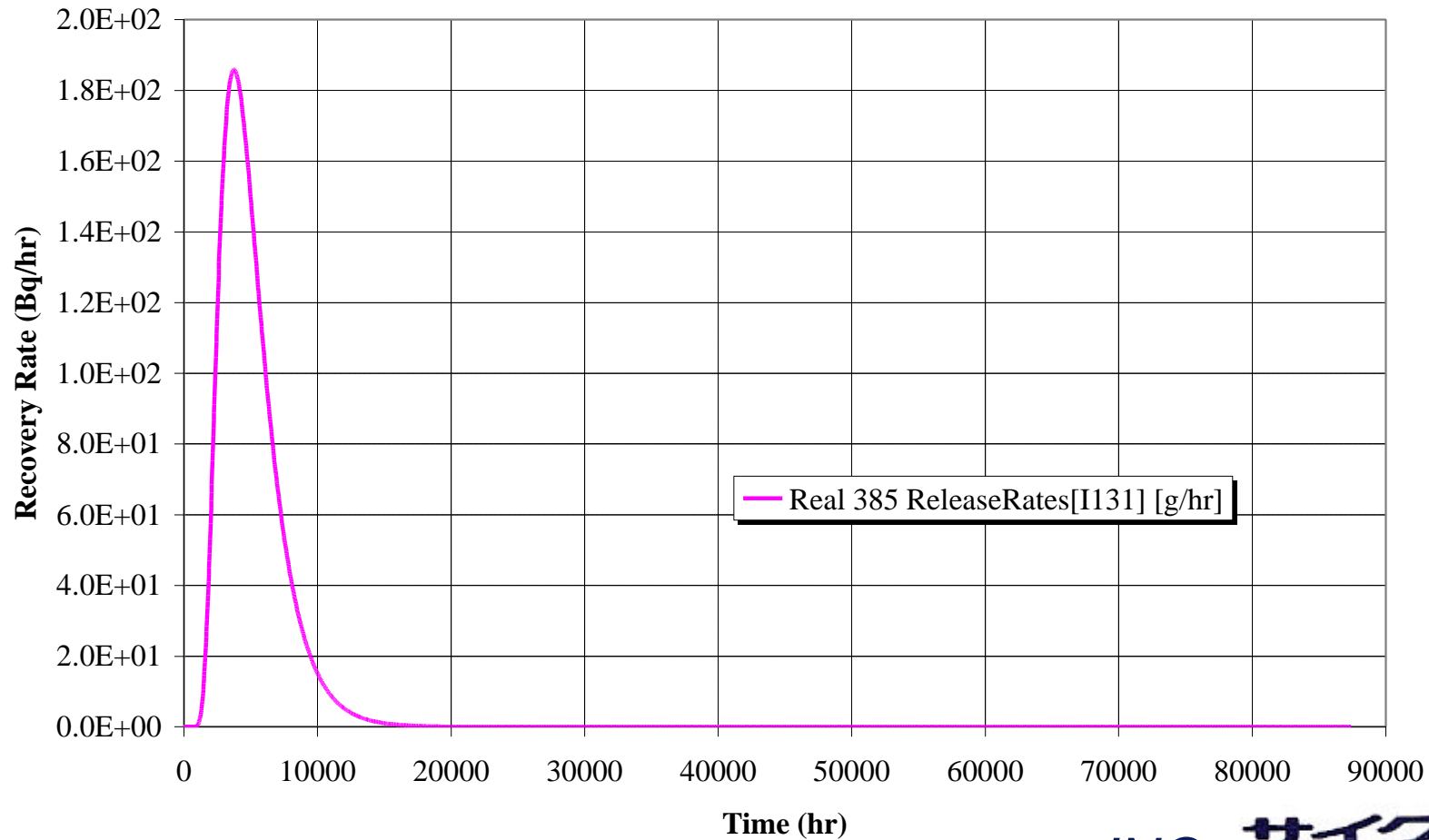




# I-131 Breakthrough at PA Time Scales

## Real 385

I-131 Release Rate



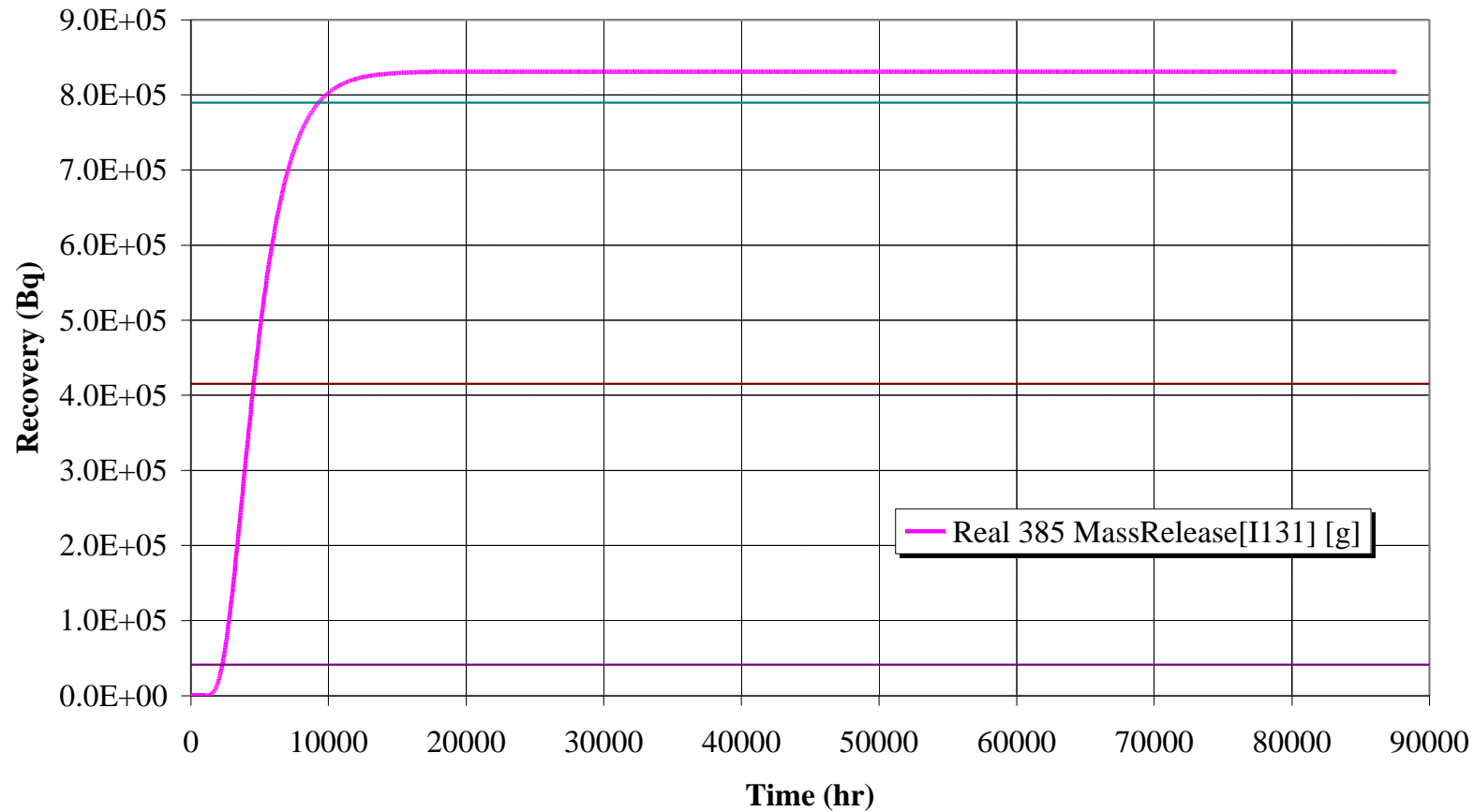


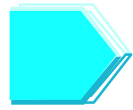


# I-131 Breakthrough at PA Time Scales

## Real 385

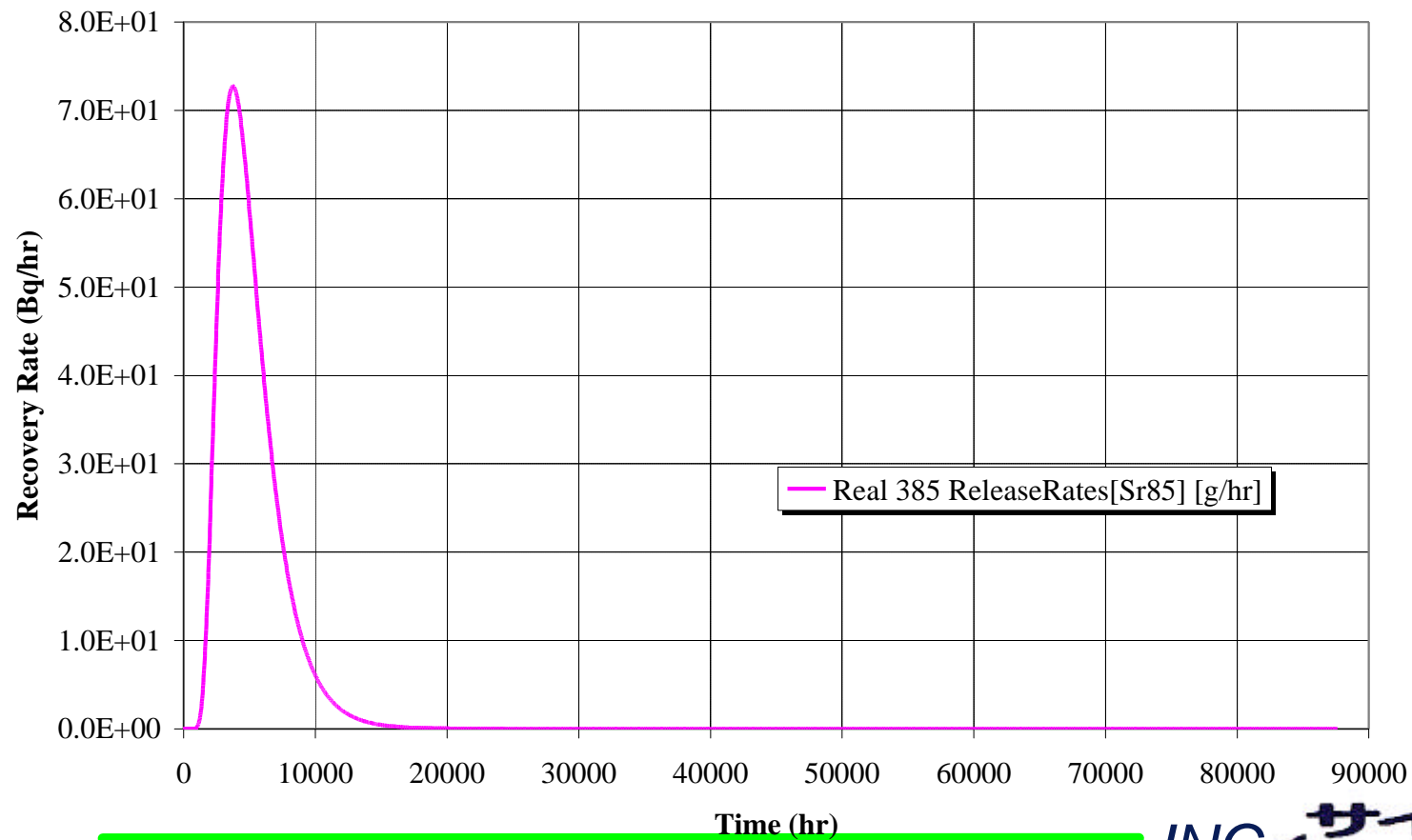
I-131 Cumulative Release



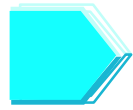


# Sr-85 Breakthrough at PA Time Scales Real 385

Sr-85 Release Rate

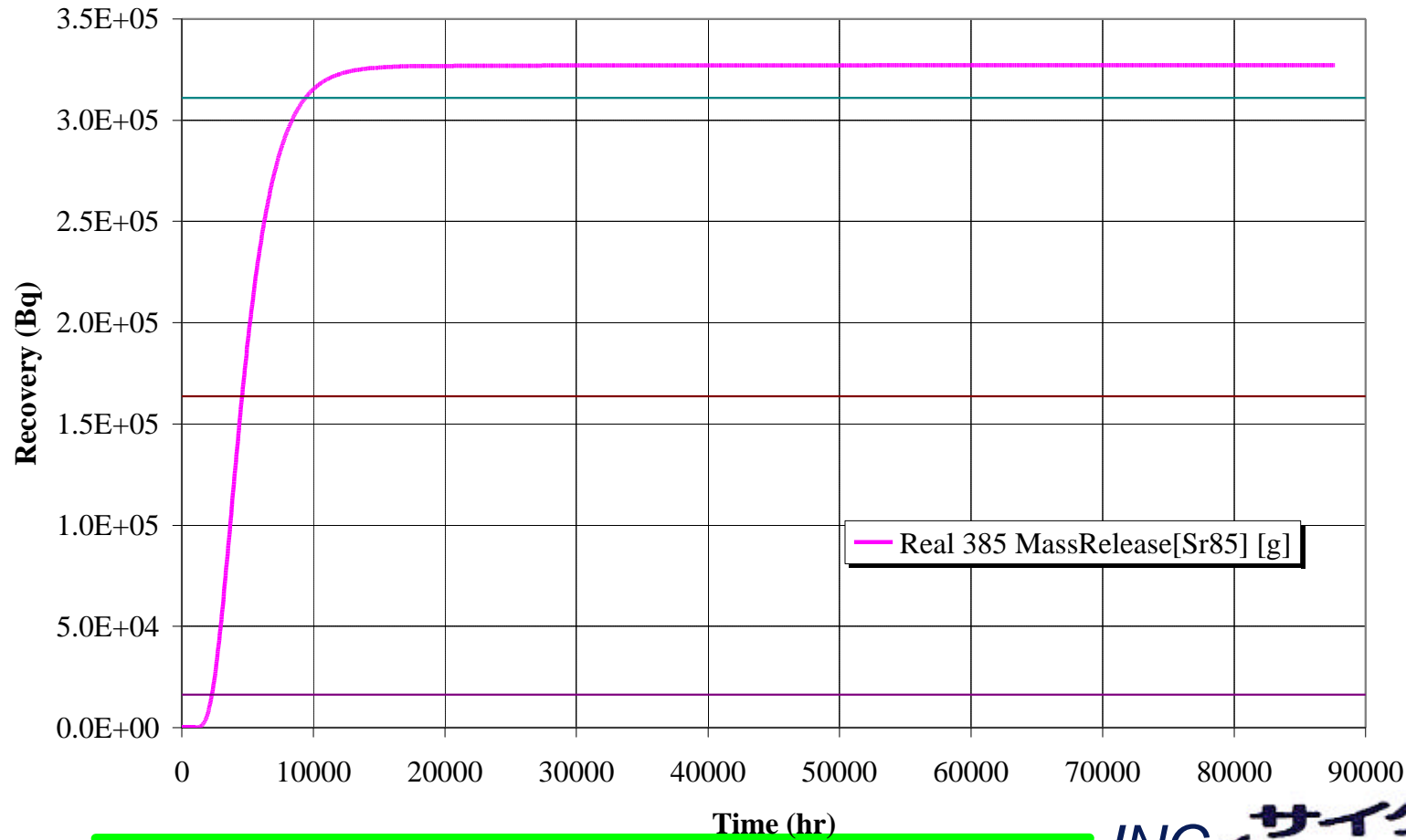


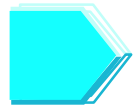
923 1089.H13



# Sr-85 Breakthrough at PA Time Scales Real 385

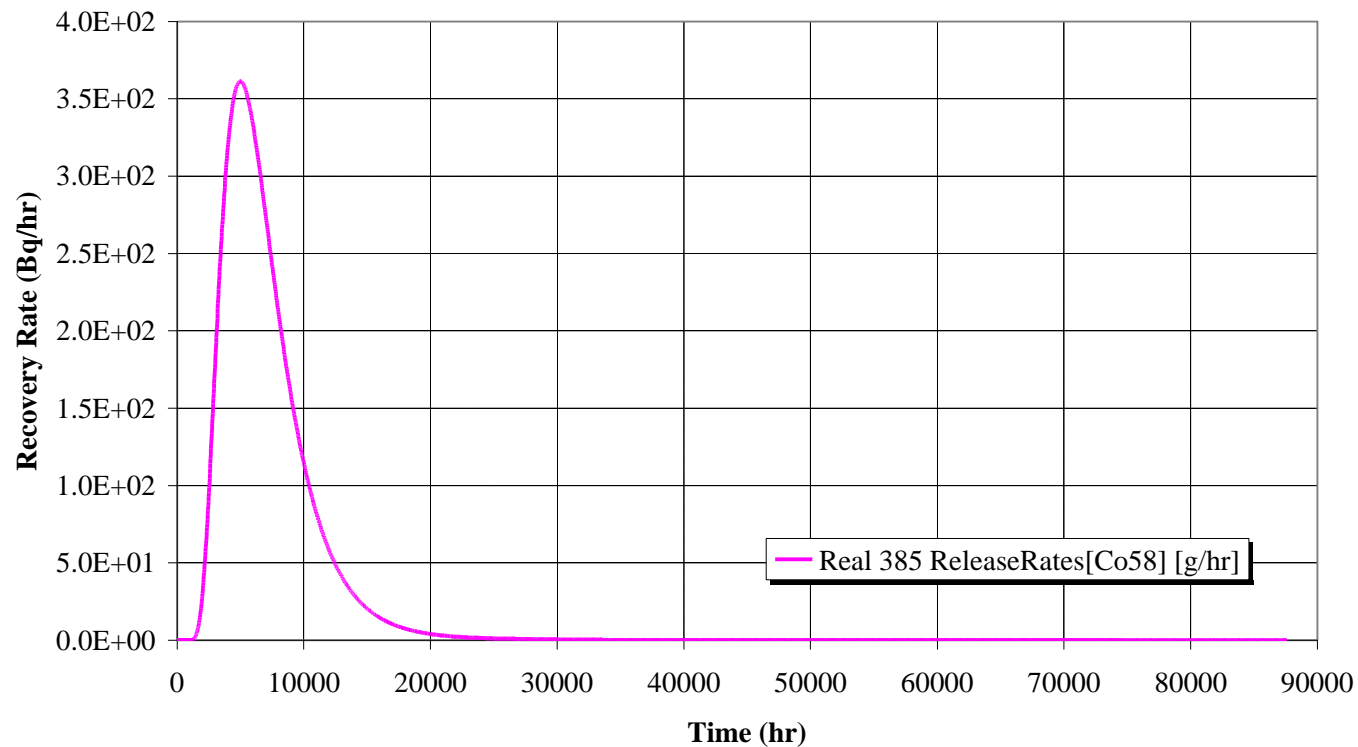
Sr-85 Cumulative Release





# Co-58 Breakthrough at PA Time Scales Real 385

Co-58 Release Rate

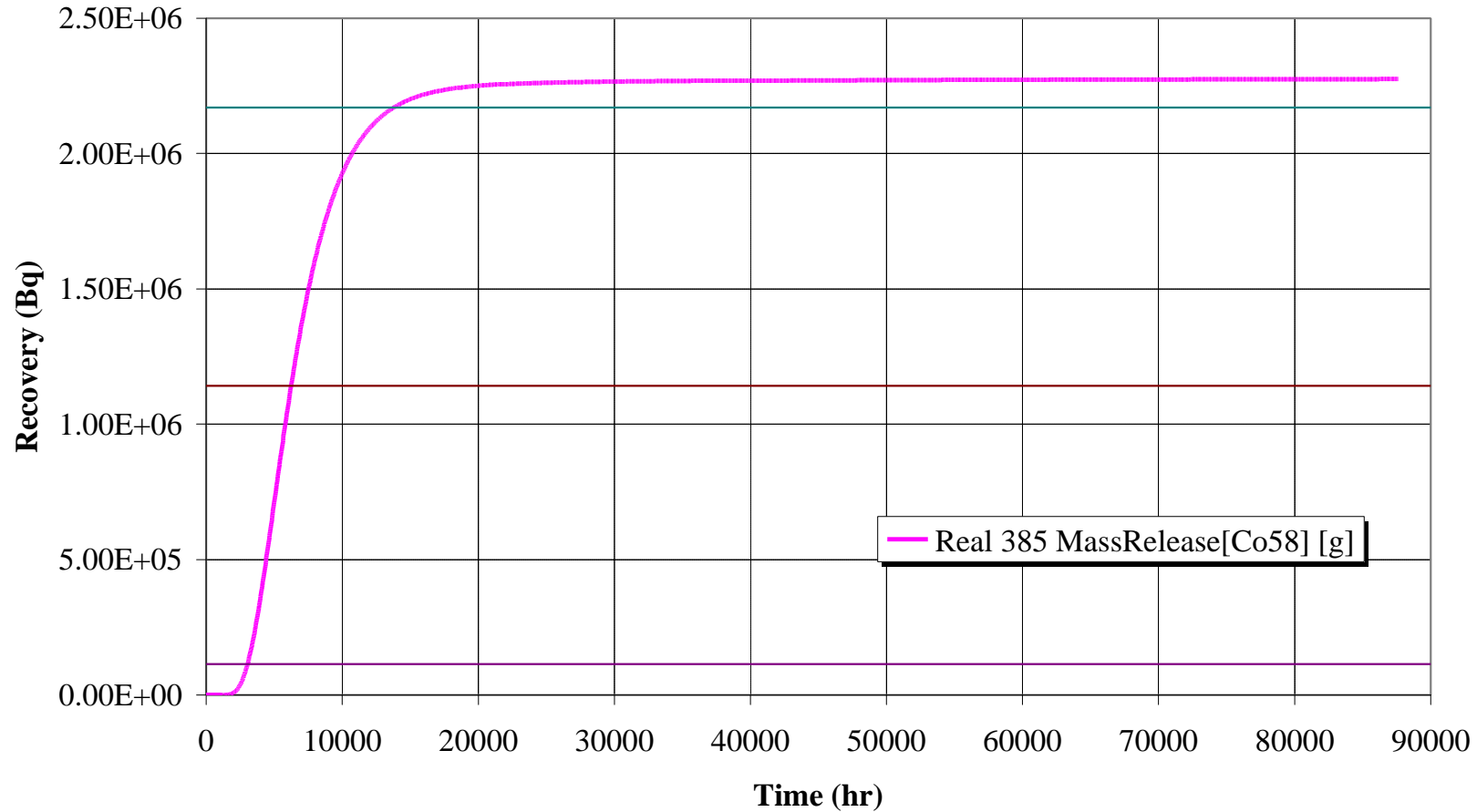


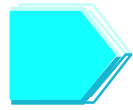


# Co-58 Breakthrough at PA Time Scales

## Real 385

Co-58 Cumulative Release

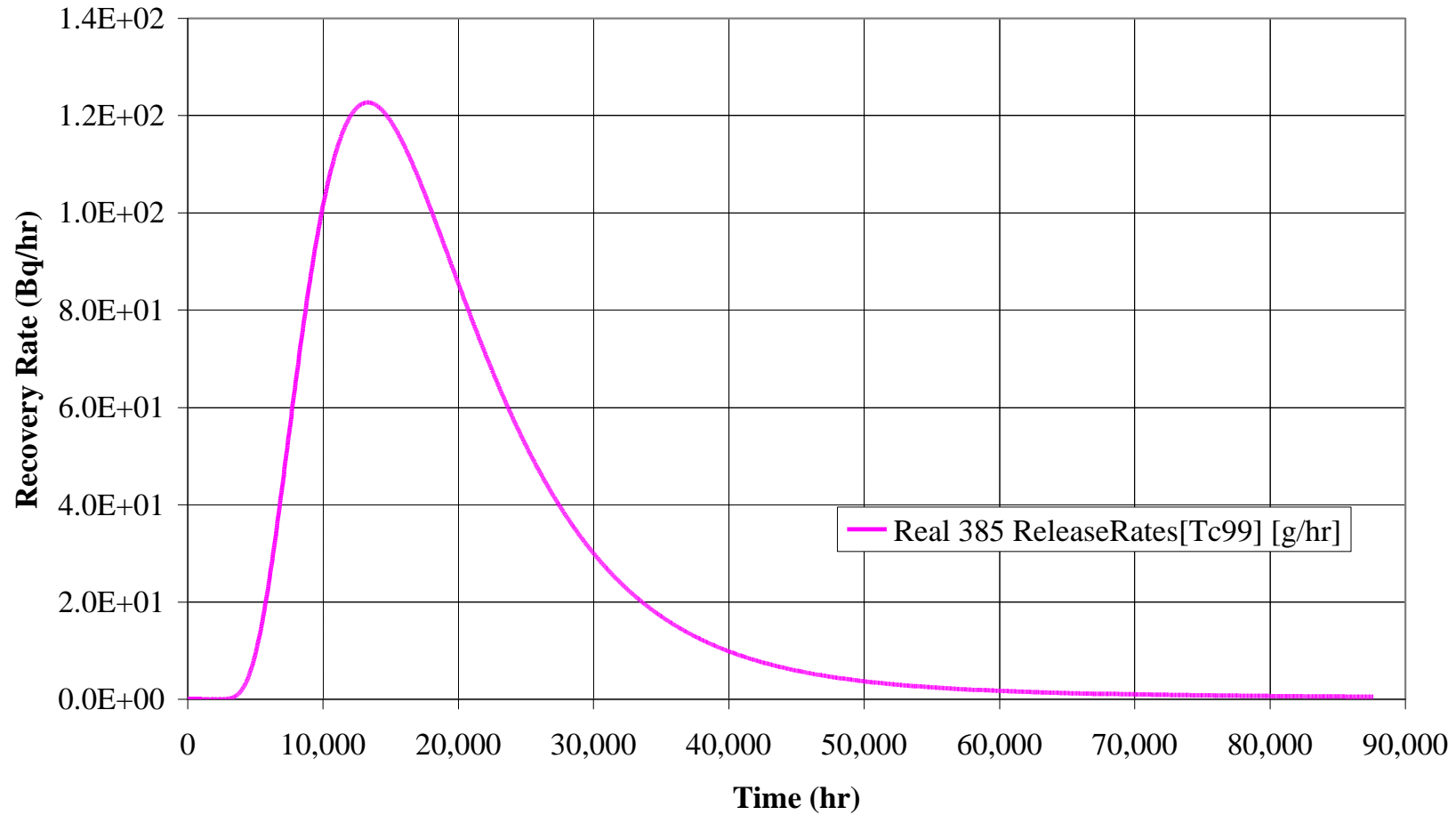


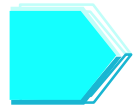


# Tc-99 Breakthrough at PA Time Scales

## Real 385

Tc-99 Release Rate

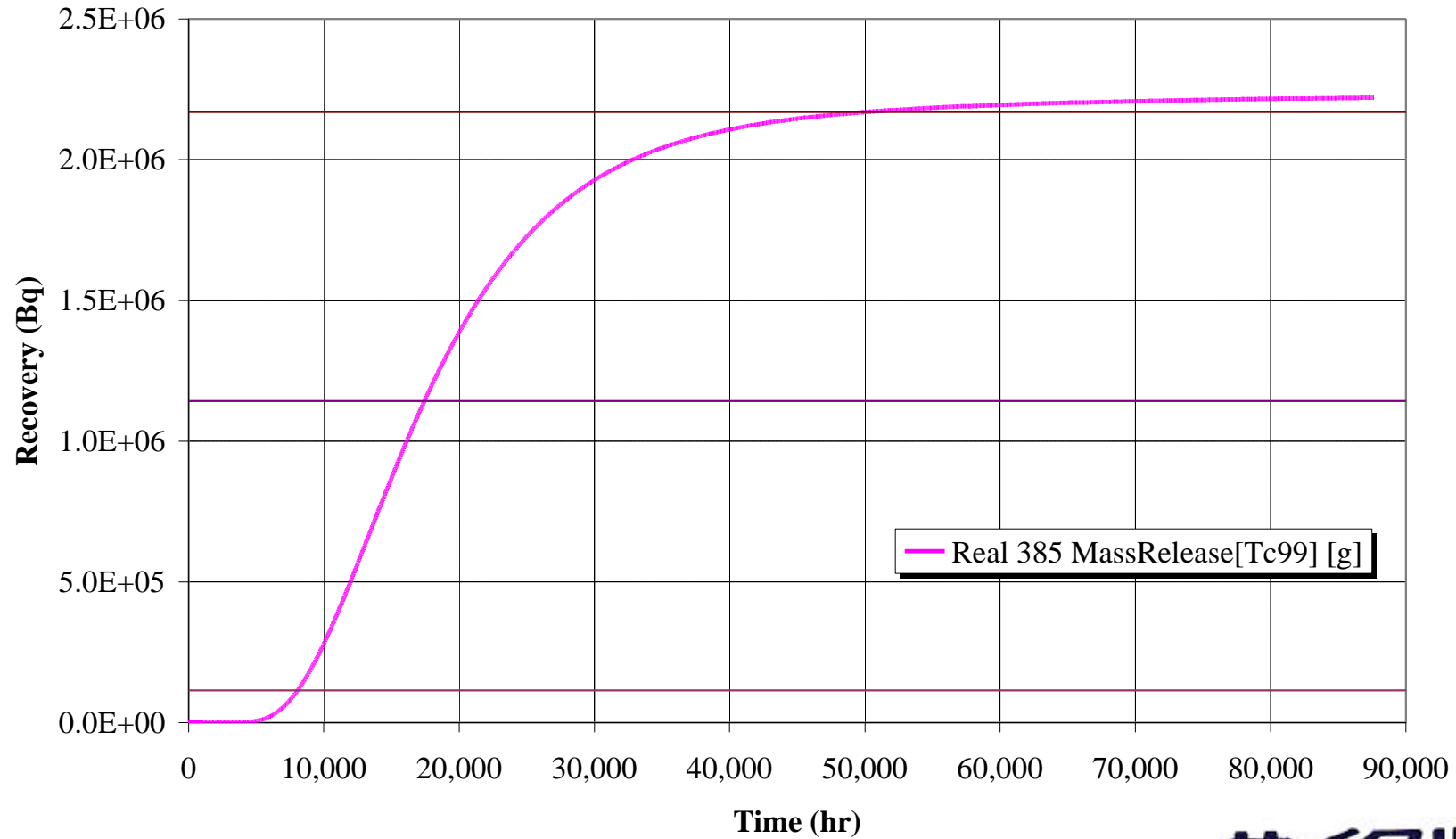




# Tc-99 Breakthrough at PA Time Scales

## Real 385

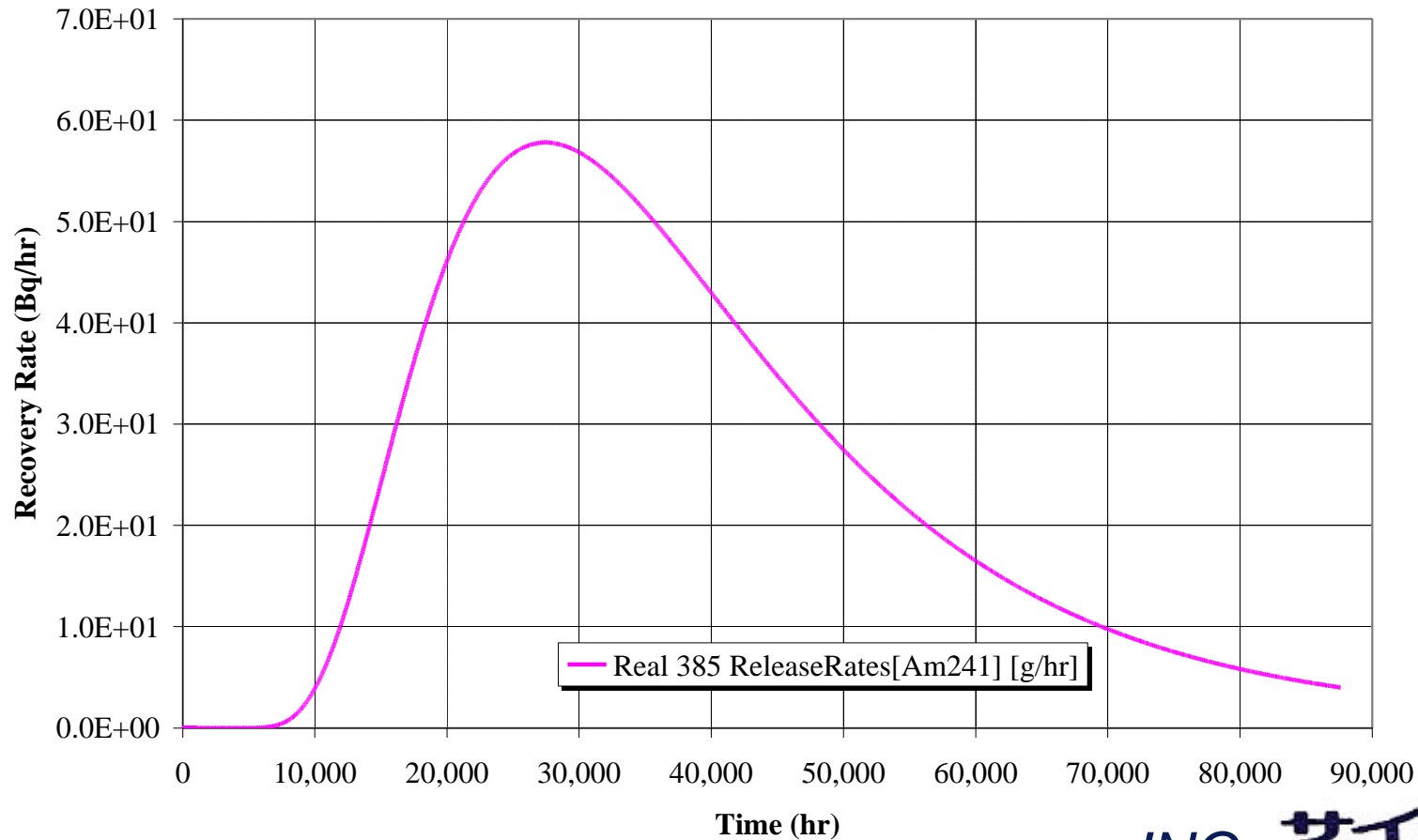
Tc-99 Cumulative Release





# Am-241 Breakthrough at PA Time Scales Real 385

Am-241 Release Rate

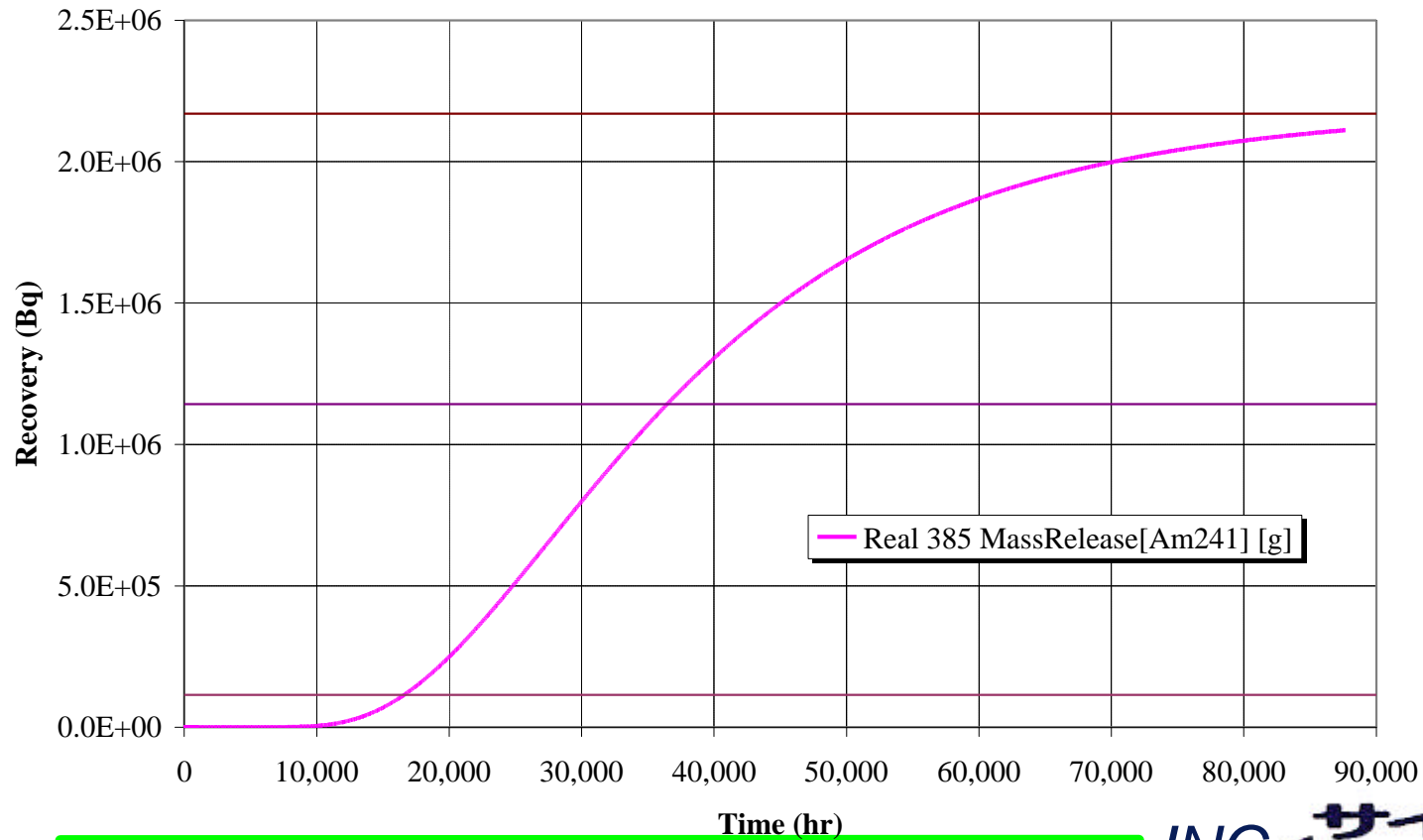






# Am-241 Breakthrough at PA Time Scales Real 385

Am-241 Cumulative Release



## Effect of PA Scale

- **The results for SC timescale tests showed:**
  - Consistent Results for HTO, I-131, and Sr-85
  - Greater Variability for Co-58, Tc-99 and Am-241
- **The results for PA timescale showed:**
  - Consistent results for HTO, I-131, Sr-85, and Co-58
  - Greater Variability for Tc-99 and Am-241
- **Variability is a function of Kd - larger Kd's are more sensitive to differences in pathway parameters which don't shown up at SC timescales**

# Conclusions

- STT-1b tracer test in an of itself did not constrain the pathway properties very precisely. Within the physically possible range, there are a remarkably large number of combinations of parameters which can match observed breakthroughs.
- Simulations indicate that diffusion was an important process for the STT-1b experiments.
- The importance of diffusive processes can be quantified in terms of the diffusive/advective volume ration and the factor  $K F t$
- The range of immobile zone properties from the STT-1b tracer test results in an even larger range of possible breakthroughs at the PA time scale.
- Diffusion into the mylonite/altered wall rock immobile zone and the rock matrix immobile zone are very important at PA timescales
- Higher  $K_d$  values solutes are more sensitivite to the porosity and geometry of the rock mass immobile zone

## Appendix M

Demonstration simulations for T6B2 fracture network  
flow and transport  
W. Dershowitz (Golder/JNC)



# Demonstration Simulations Task 6B2

## PA Time Scale Transport in a Single Fracture with PA Boundary Conditions

Äspö Task 6

Integrated Performance Assessment and Site  
Characterization Modeling

11 September, 2001

**Masahiro Uchida/JNC**

**Bill Dershowitz/Golder**

**Dawn Shuttle/Golder**

# PA Boundary Conditions

## ■ Task 6B

- RC Radially converging flow is essentially 1D.
- Any Heterogeneity in the 1D Flow can be incorporated to “effective” 1D transport properties
- Not particularly realistic BC’s for PA

## ■ Task 6B2

- 2D Flow Field with downstream fracture intersection boundary condition
- Heterogeneity on the Fracture Plane
- Solution using PAWorks/LTG (SC Code) rather than GoldSim (PA Code)

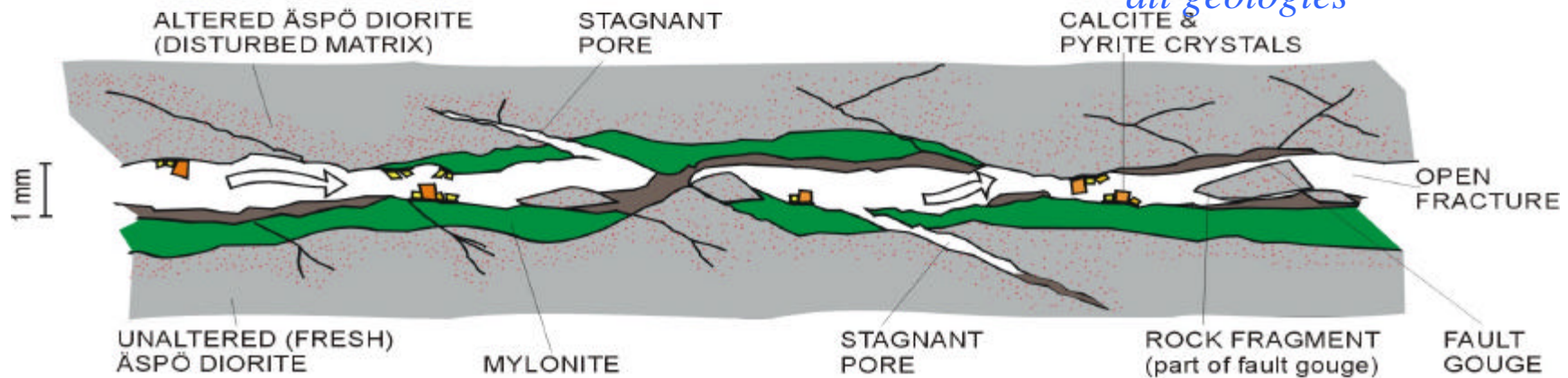
# Transport Conceptual Model

after Winberg (2000), considering Mazurek (2000)

*Skin Zone of  
Mylonite/Altered Wall  
Rock*

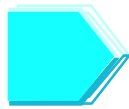
*Lowest Porosity is  
Unlimited Diffusion  
Rock Mass*

*Immobile Zones in  
parallel,  
allowing some diffusion to  
all geologies*

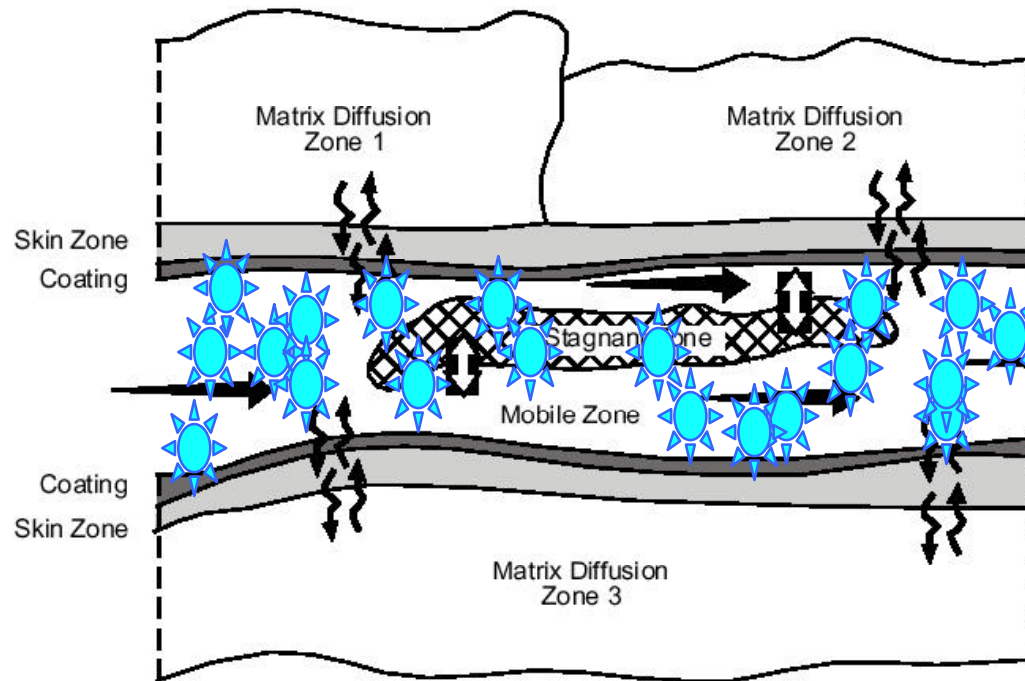


*Varying Velocity in Advective Zone  
Represented by Varying Flow Field  
From MAFIC*

*Breccia/Gouge Immobile Zones  
for Diffusion*



# Implementation of Conceptual Model JNC PAWorks/LTG3



- Longitudinal Advective/Dispersive Transport
- Advective Mixing
- Diffusive Transport

Varying Velocity in Advective Zone Represented by Dispersion. Advective Zone is very small since fracture is mostly filled

Breccia/Gouge Immobile Zones for Diffusion

Skin Zone of Mylonite/Altered Wall Rock

Lowest Porosity is Unlimited Diffusion  
Rock Mass

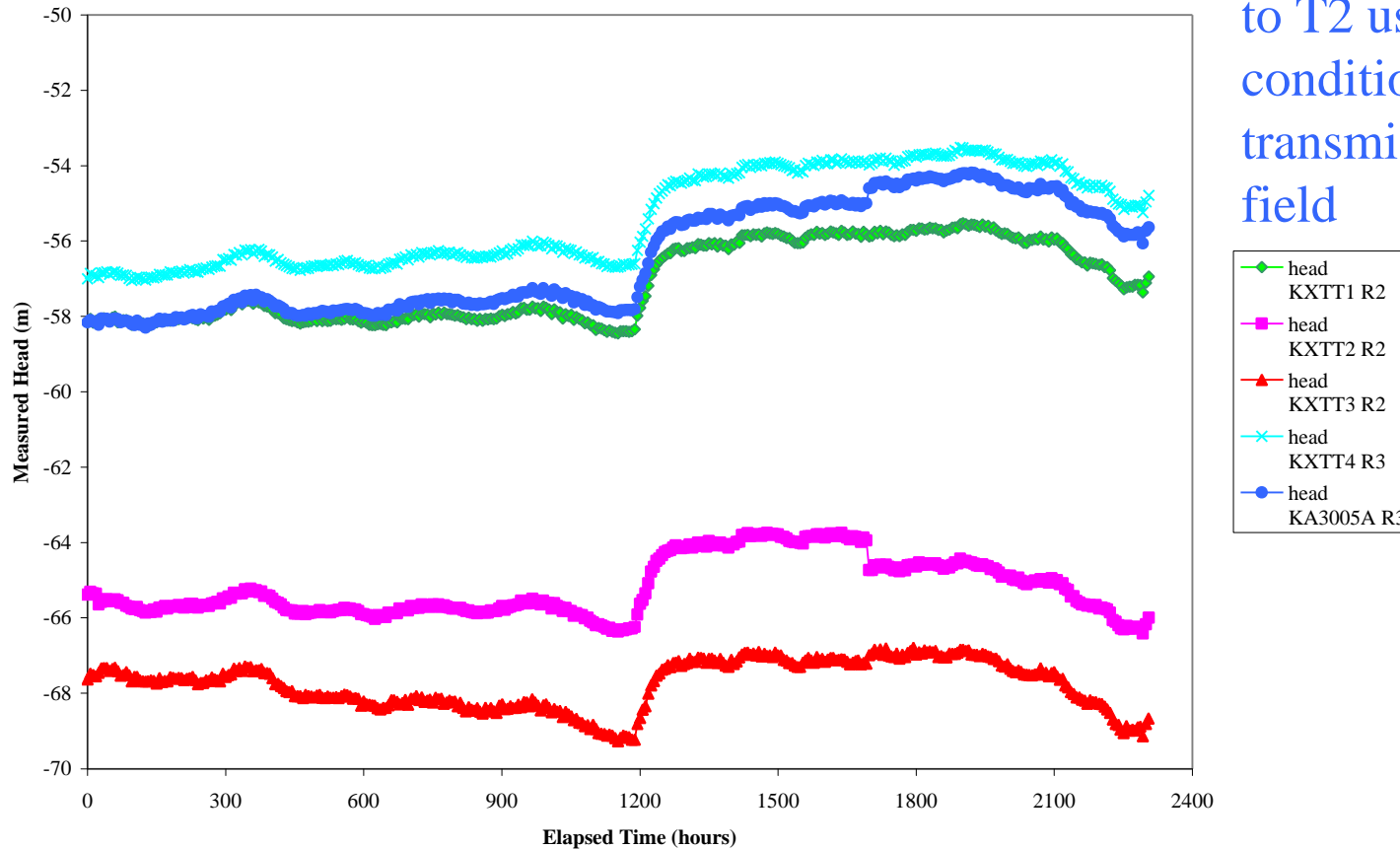


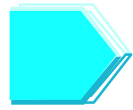


# Variation of Head with Elapsed Time

Measured Head with Elapsed Time since 00:14:41 December 1, 1997

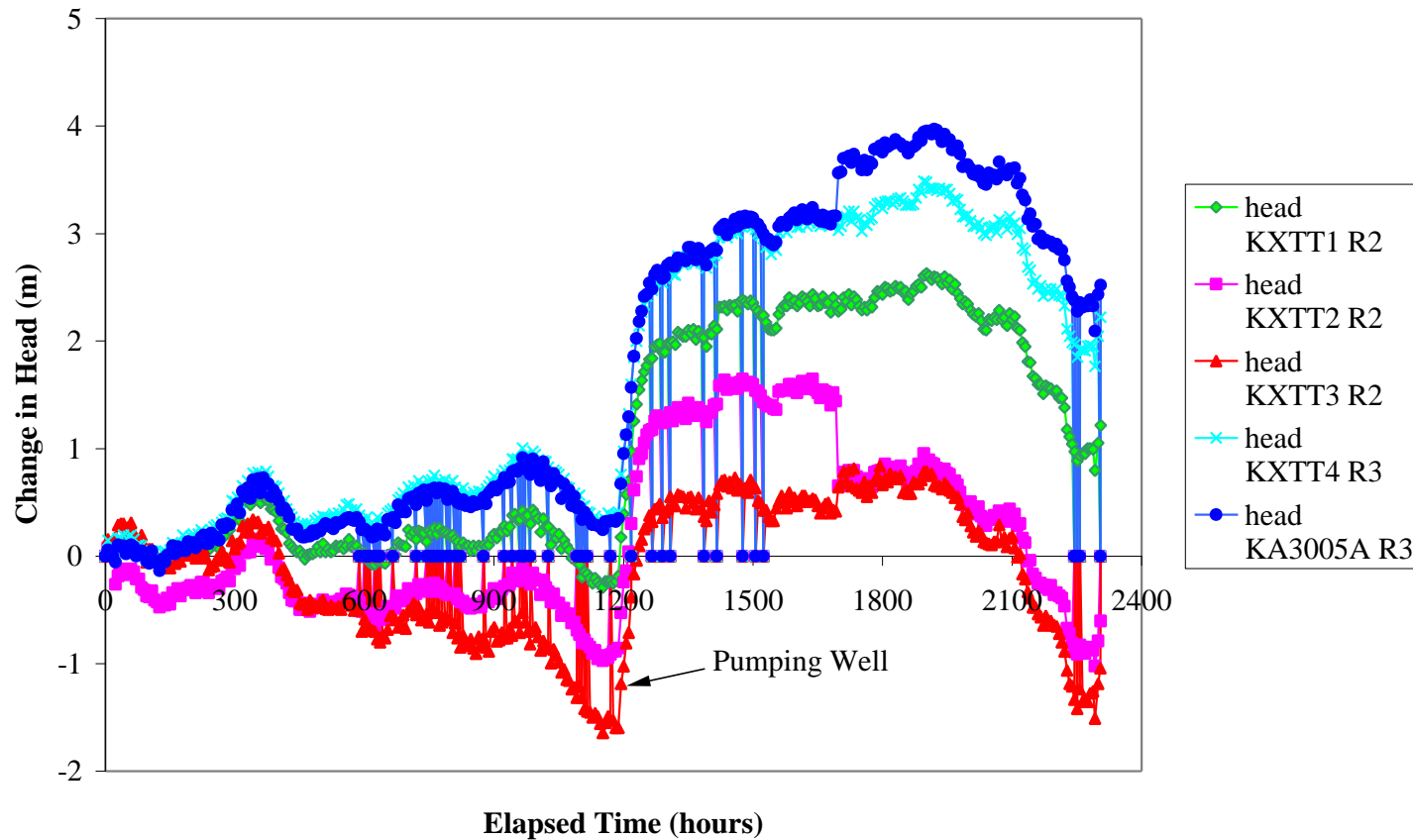
Head drop T1 to T2 used to condition transmissivity field

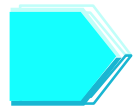




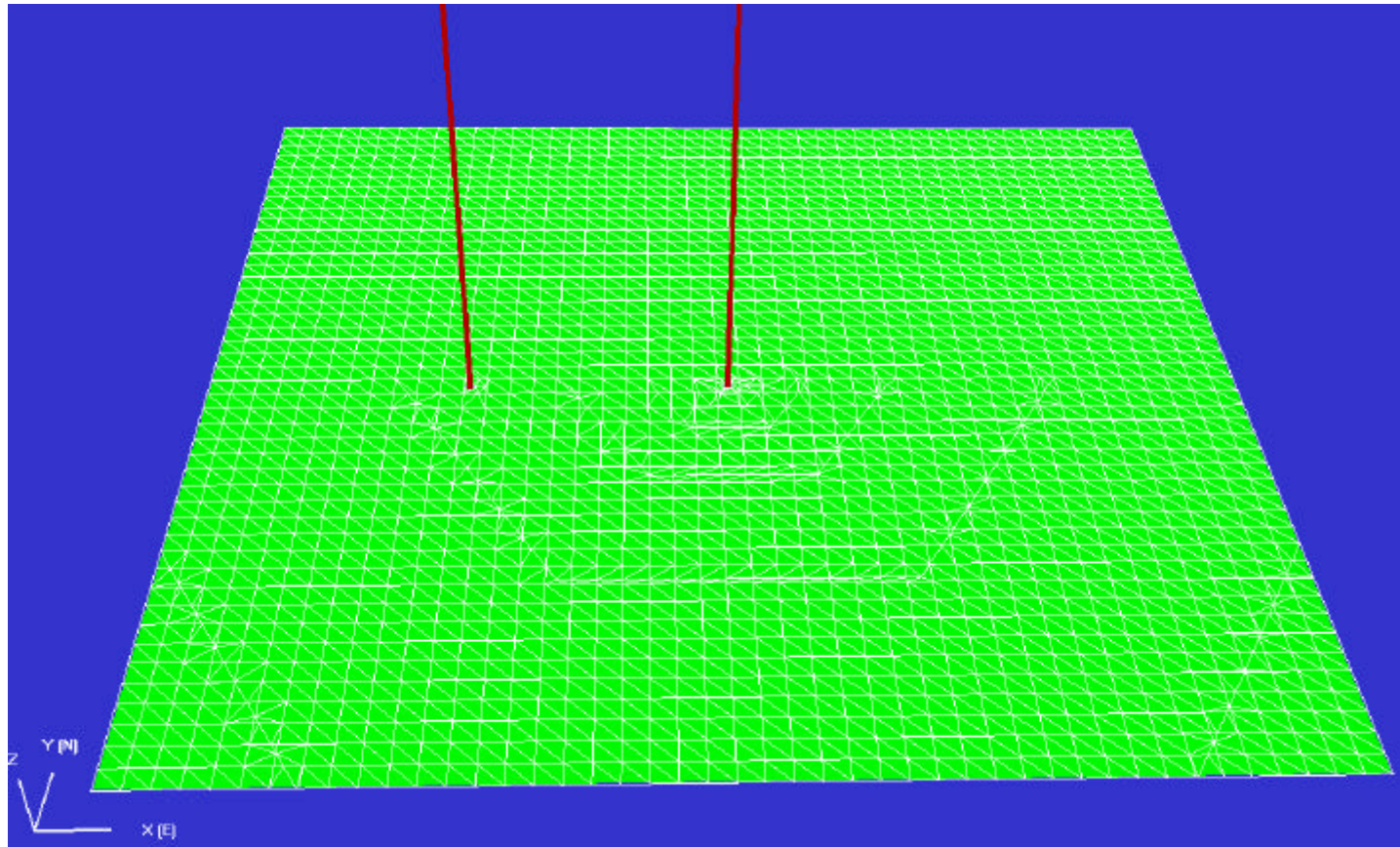
# Variation of Head with Elapsed Time

Change in Head with Elapsed Time since 00:14:41 December 1, 1997

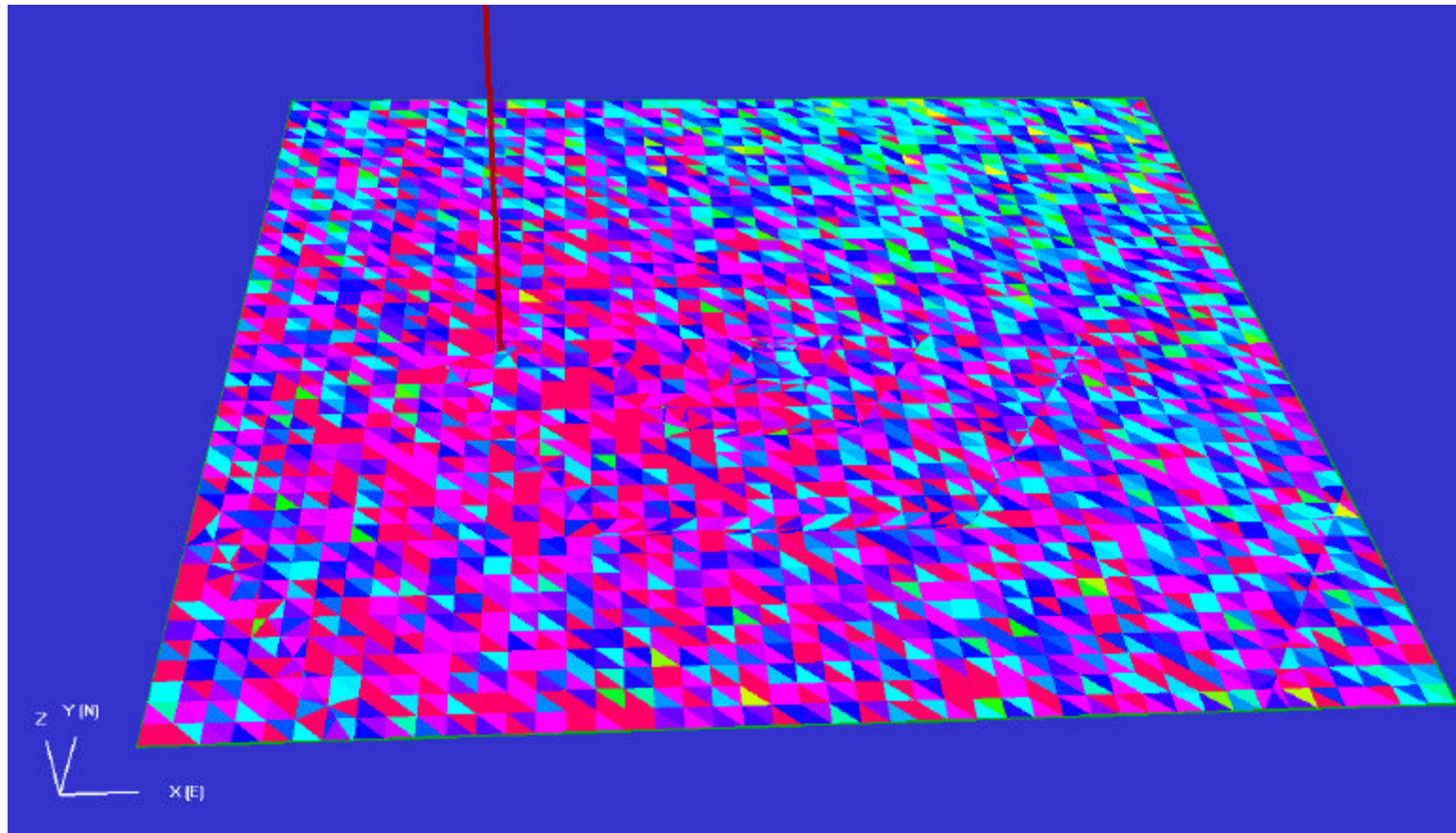


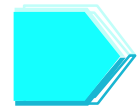


# Single Fracture Representation of Feature A



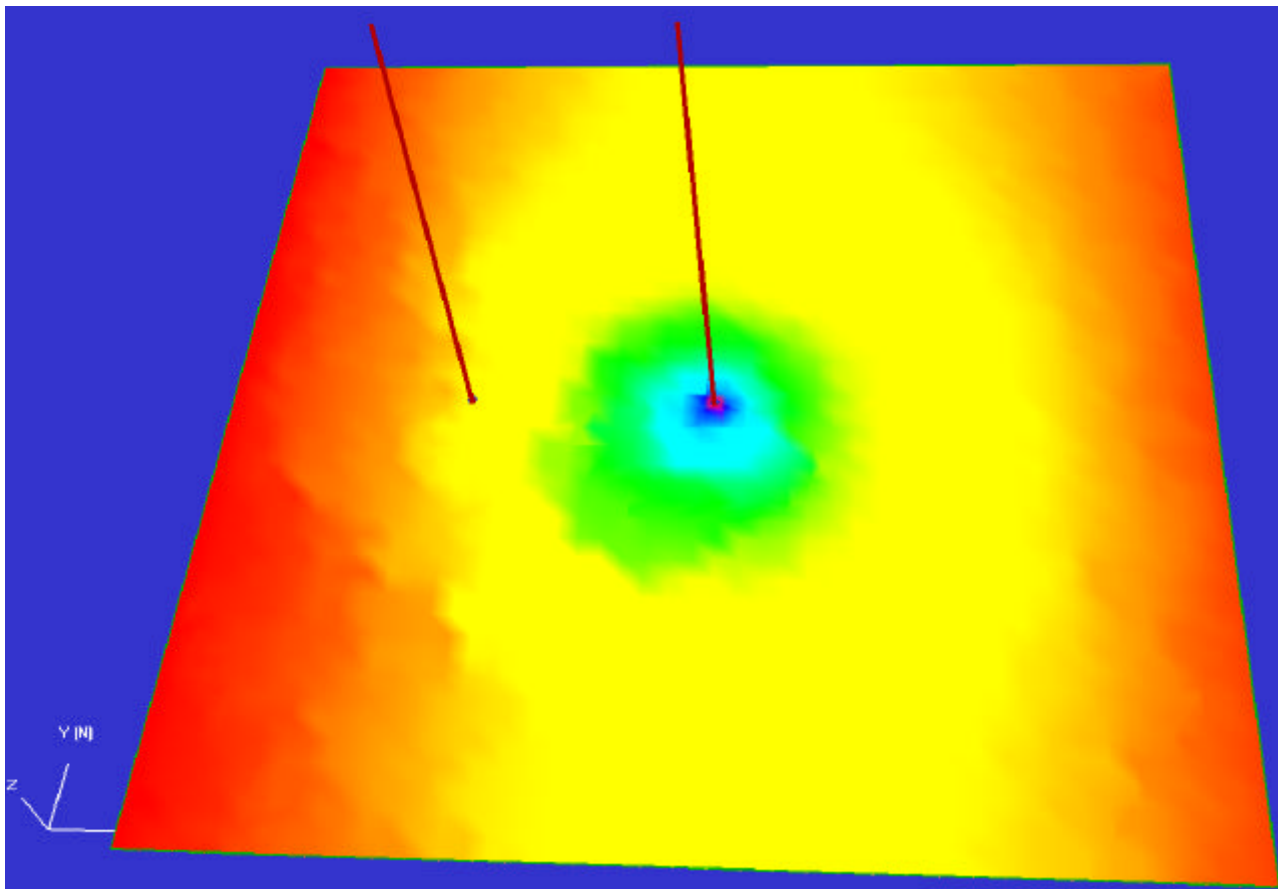
# Transmissivity Distribution

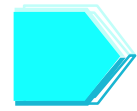




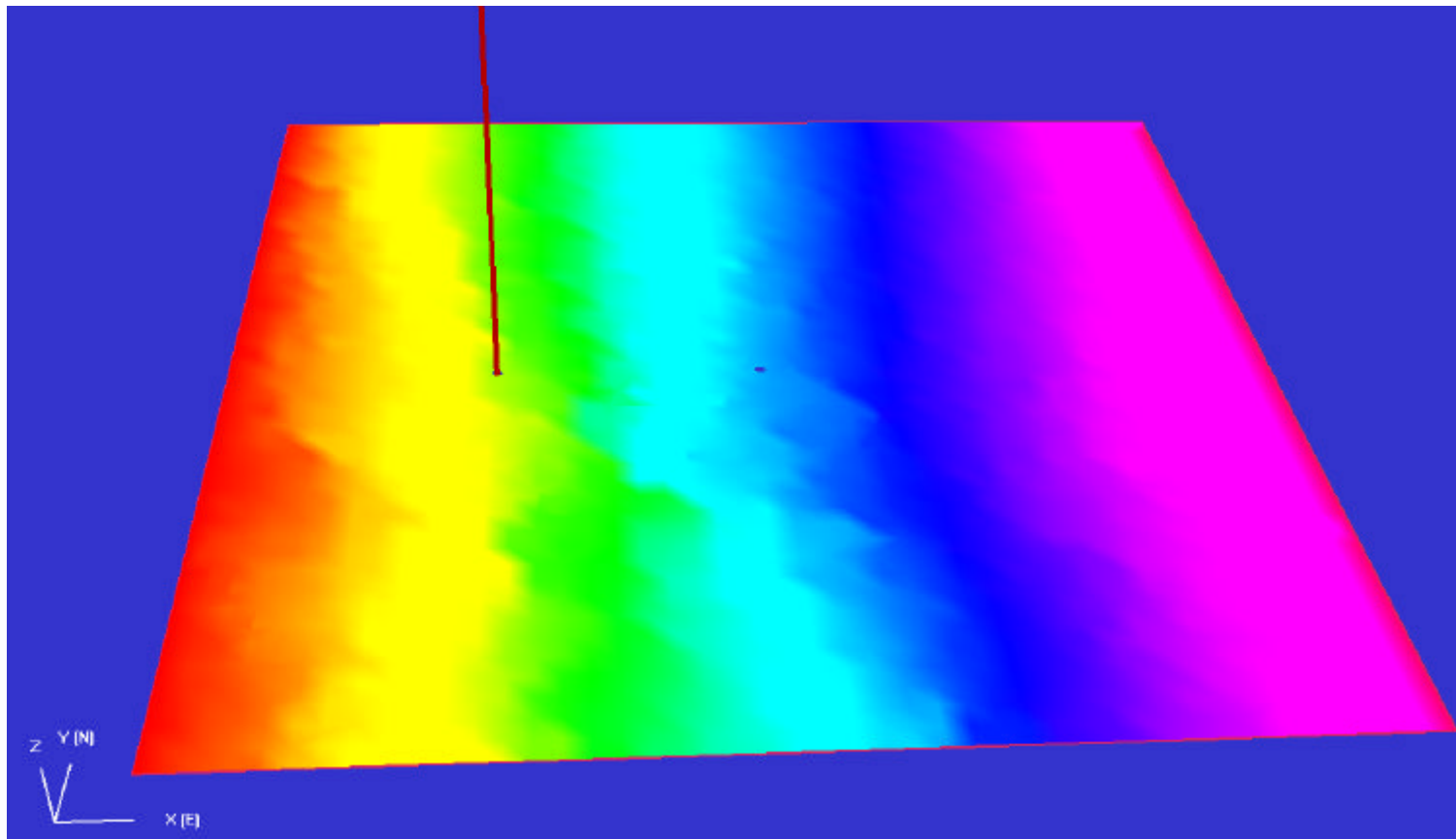
# Head solution for Task 6A

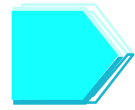
## *Radially Converging Flow*





# Head Solution for Task 6B2: *2D Flow*





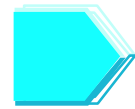
# Comparison of Boundary Conditions 6B (RC) and 6B2 (2D)

## Radially Converging

Property	Parameter Value
Injection Rate	$1.61 \times 10^{-10} \text{ m}^3/\text{s}$
Pumping Rate	$-6.67 \times 10^{-8} \text{ m}^3/\text{s}$
Change in Head	-0.05 m

## 6B2 Boundary Conditions

Property	Parameter Value
Injection Rate	$1.61 \times 10^{-10} \text{ m}^3/\text{s}$
Pumping Rate	0.0 $\text{m}^3/\text{s}$
Change in Head across Feature 'A'	0.016 m



# Transport Properties for 6B and 6B2

Initial Example uses the properties from GoldSim Rev5, Realization 385

Property	Units	Parameter Value
Aperture	mm	$0.025 T^{0.5}$
Dispersion Length	m	0.5
Breccia Porosity	-	0.2314
Breccia Dmax	mm	0.272
Mylonite Porosity	-	0.014
Mylonite Dmax	mm	0.054
Rock Mass Porosity	-	0.00127
Rock Mass Dmax	mm	56.2
Tortuosity	-	0.0125

Tracer	Property	Units	Value
HTO	Kd	$m^3/kg$	0.0
	$D_0$	$m^3/s$	$2.4 \times 10^{-9}$
I-131	Kd	$m^3/kg$	0.0
	$D_0$	$m^3/s$	$1.66 \times 10^{-9}$
Sr-85	Kd	$m^3/kg$	$1.3 \times 10^{-4}$
	$D_0$	$m^3/s$	$7.9 \times 10^{-10}$

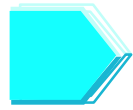


## Task 6B vs 6B2 Simulations

- 6B travel length 5 meters. 6B2 15 meters
- Same Source Term
- Same Time Scale
- Similar Gradient
- Smooth Moving Average Heterogeneous Transmissivity and Aperture Field on Feature A in 6B2
- Dirac release

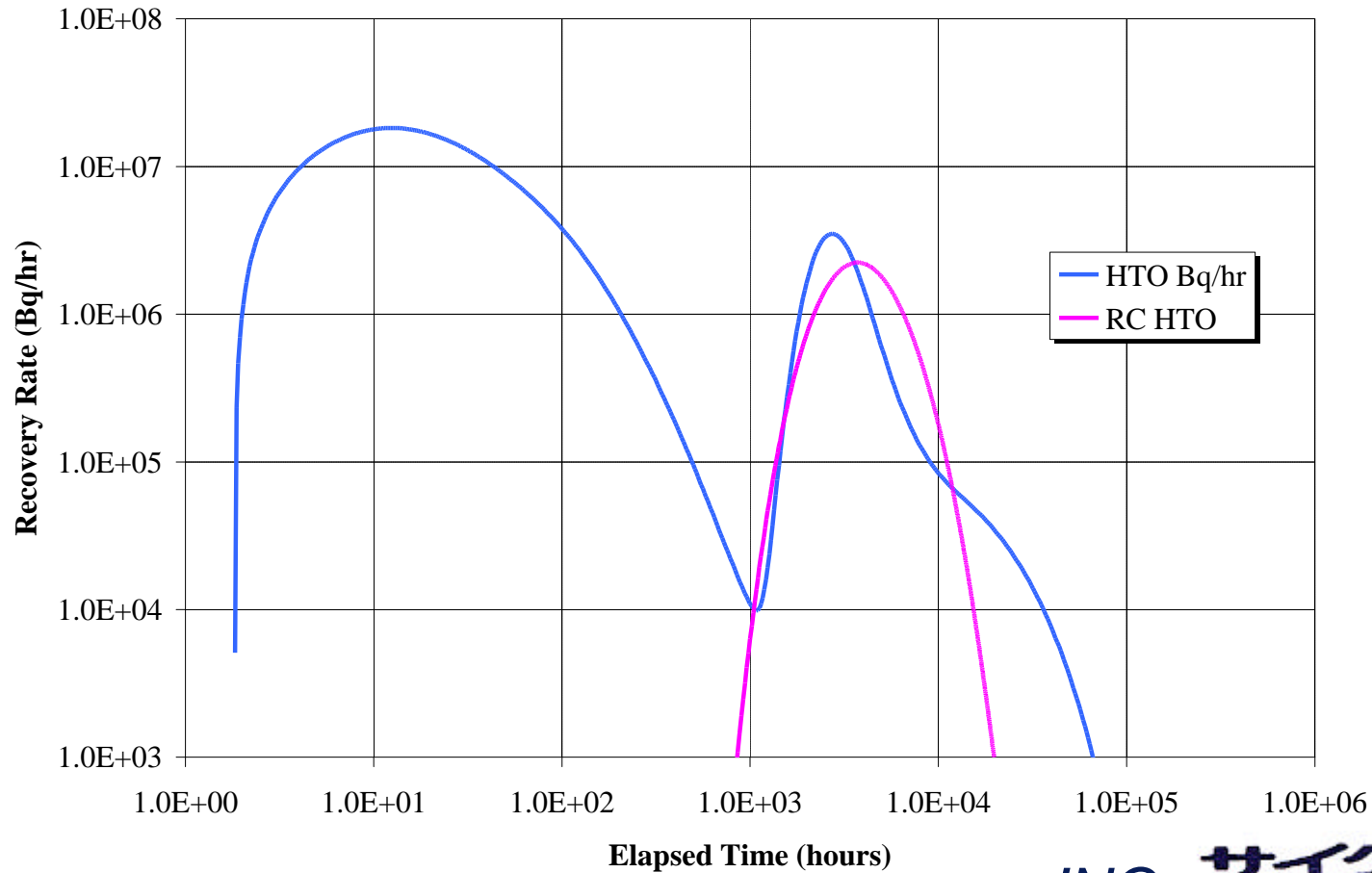
# Conservative Tracer Breakthrough

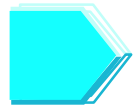
- Compare 6B and 6B2 Breakthroughs
- Compare Effective Dispersion Values
- Compare Mean Velocities
- Visualize Distribution of Concentration Along Downstream Boundary



# Conservative Tracer Breakthrough

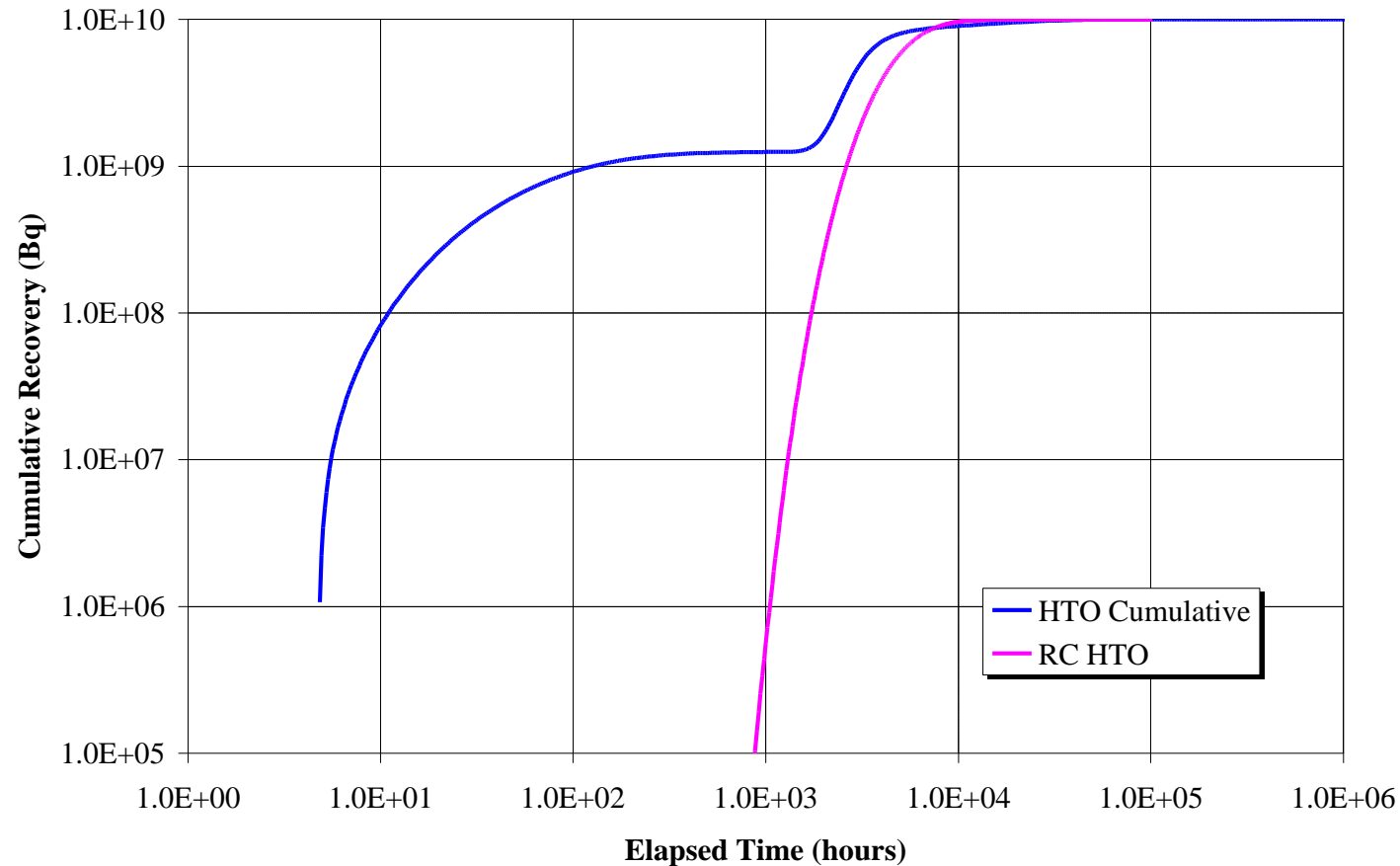
HTO Recovery Rate





# Conservative Tracer Breakthrough

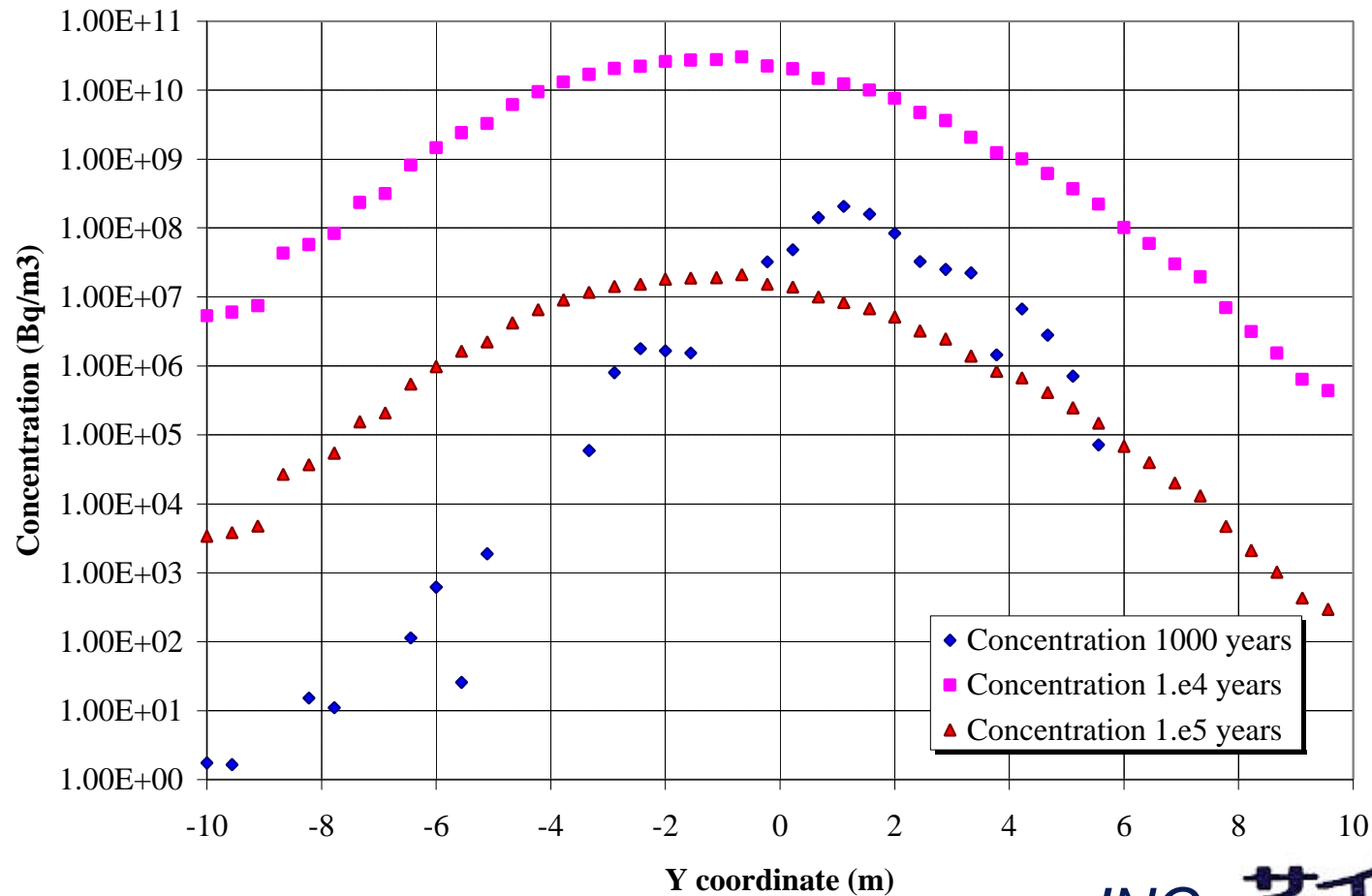
## HTO Cumulative Recovery





# Conservative Tracer Breakthrough

Concentration of HTO

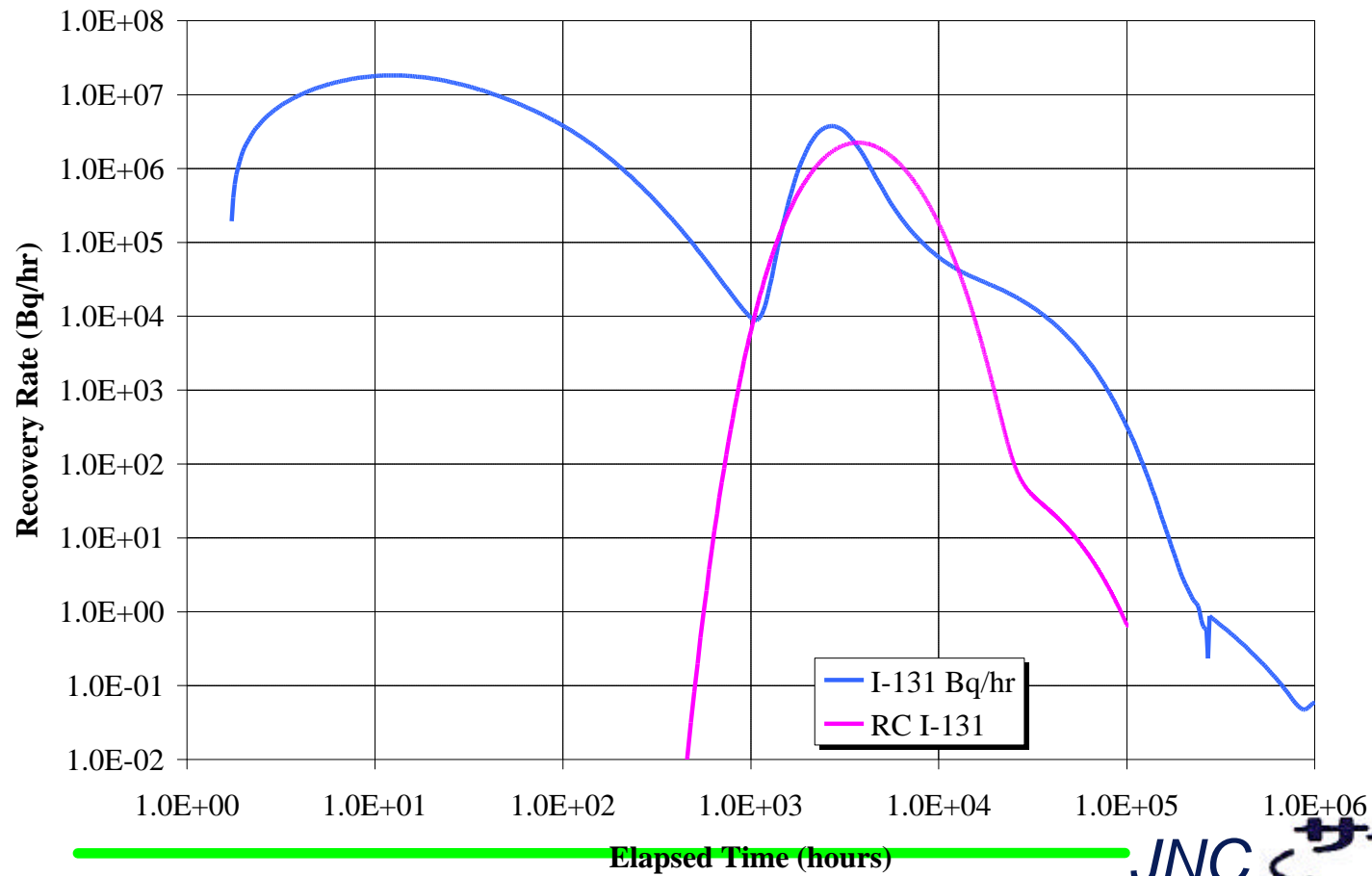


# I-131 Tracer Breakthrough

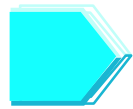
- Compare 6B and 6B2 Breakthroughs
- Compare Effective Retardation ( $t_{50}$  for  $K_d$  and  $K_d=1$ )
- Compare Effective Dispersion Values
- Compare Mean Velocities
- Visualize Distribution of Concentration Along Downstream Boundary

# I-131 Tracer Breakthrough

I-131 Recovery Rate

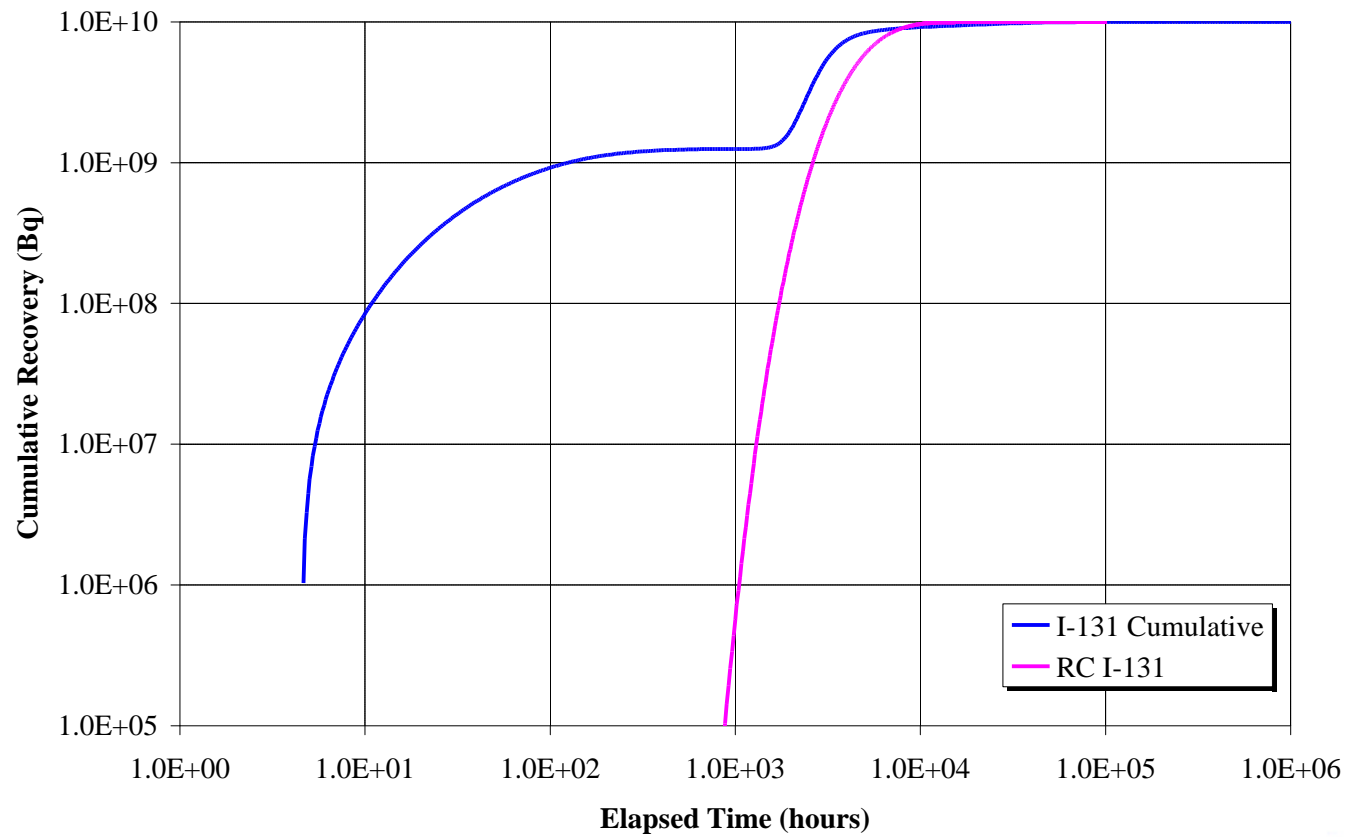


923 1089.H13

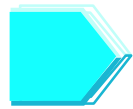


# I-131 Tracer Breakthrough

I-131 Cumulative Recovery

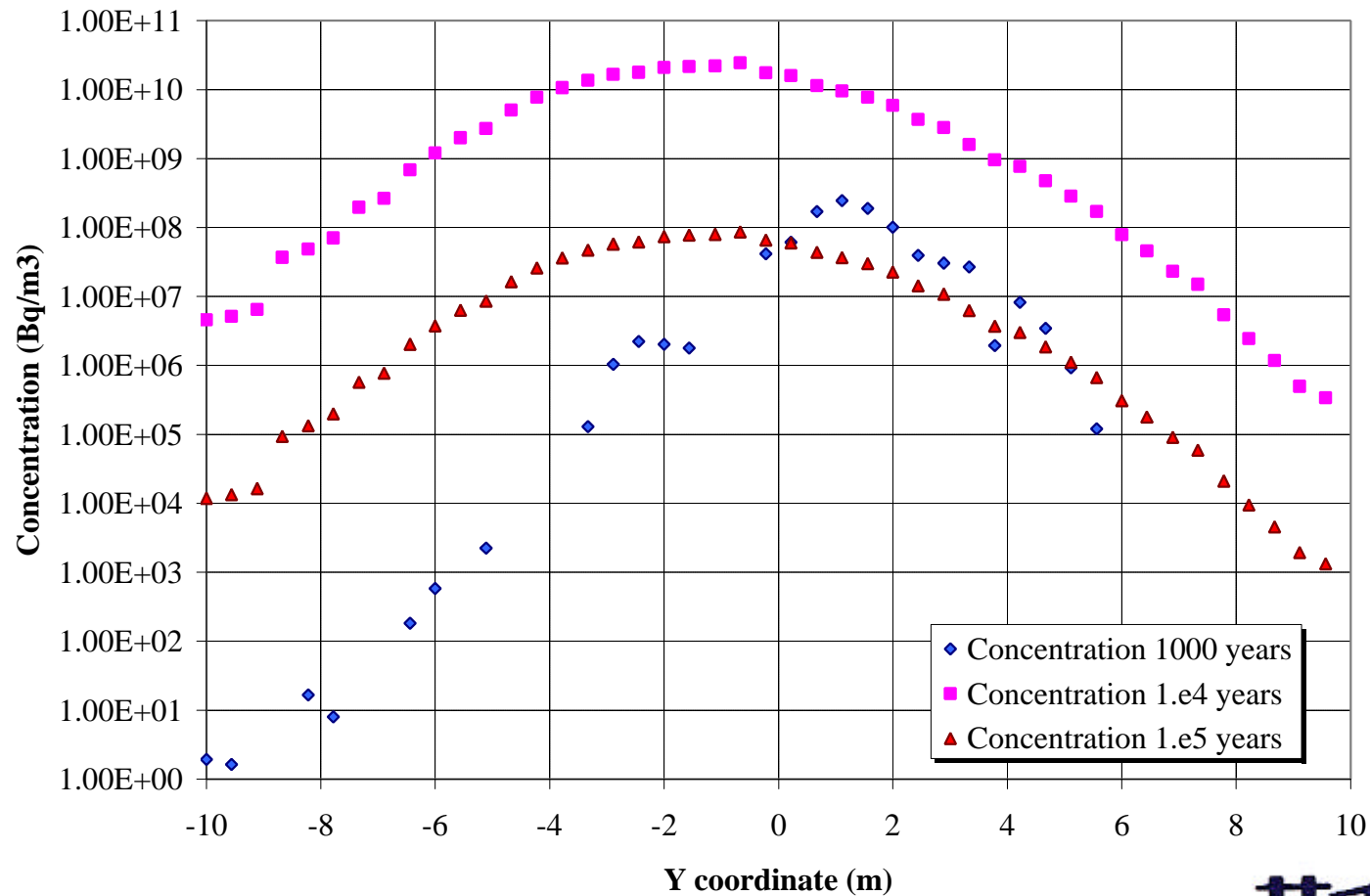






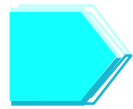
# I-131 Tracer Breakthrough

Concentration of I-131



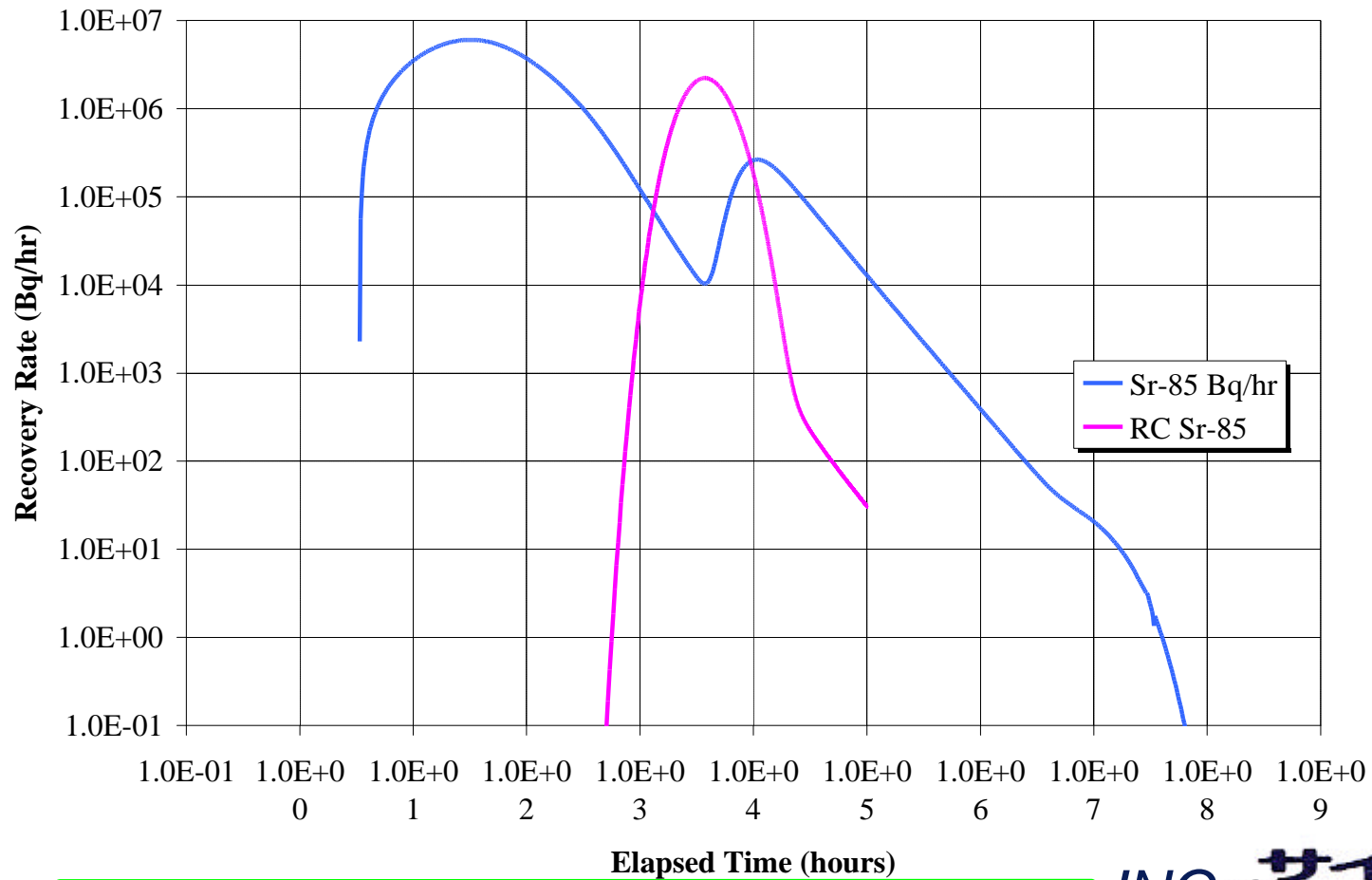
# Sr-85 Tracer Breakthrough

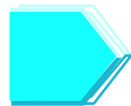
- Compare 6B and 6B2 Breakthroughs
- Compare Effective Retardation ( $t_{50}$  for  $K_d$  and  $K_d=1$ )
- Compare Effective Dispersion Values
- Compare Mean Velocities
- Visualize Distribution of Concentration Along Downstream Boundary



# Sr-85 Tracer Breakthrough

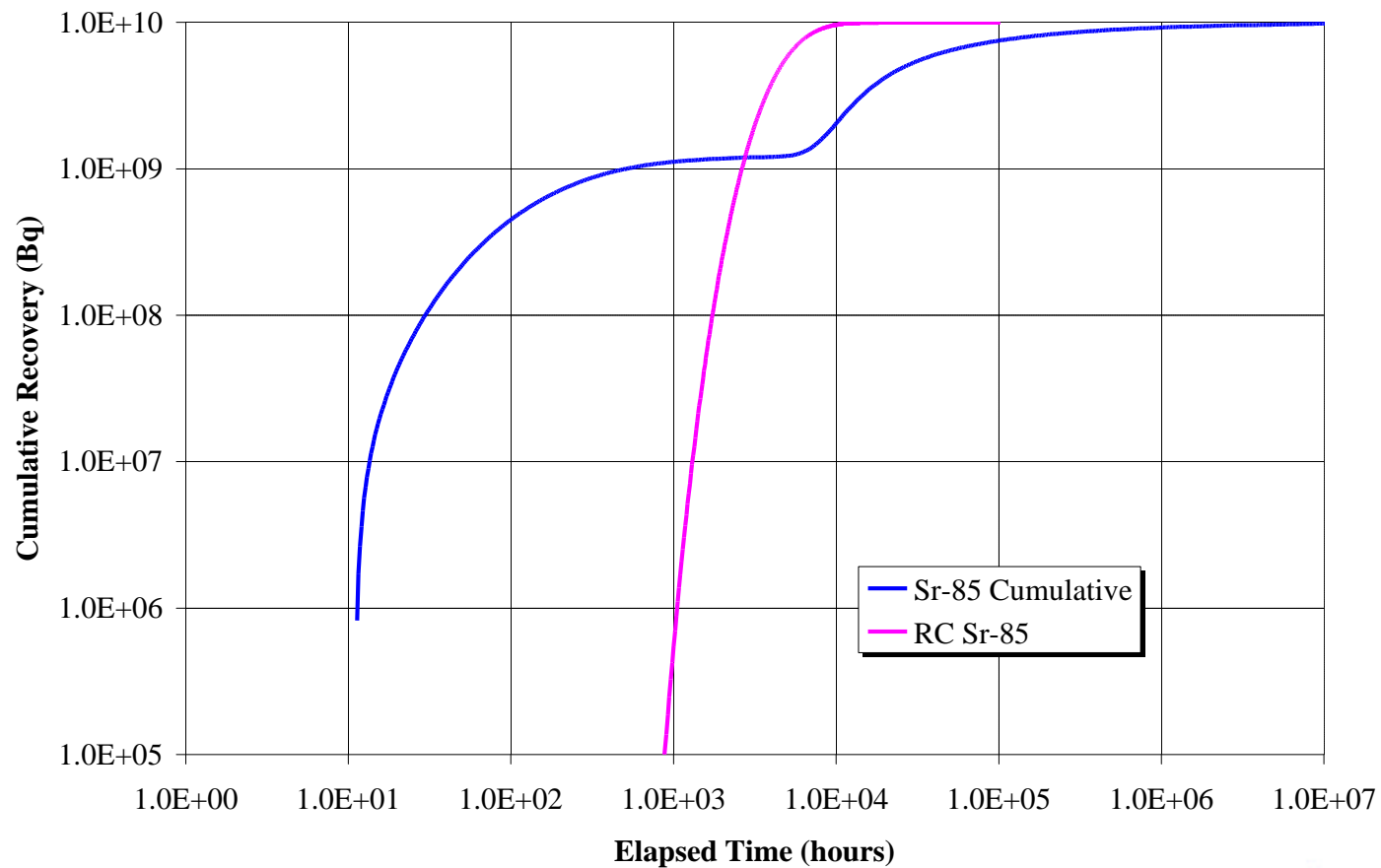
Sr-85 Recovery Rate





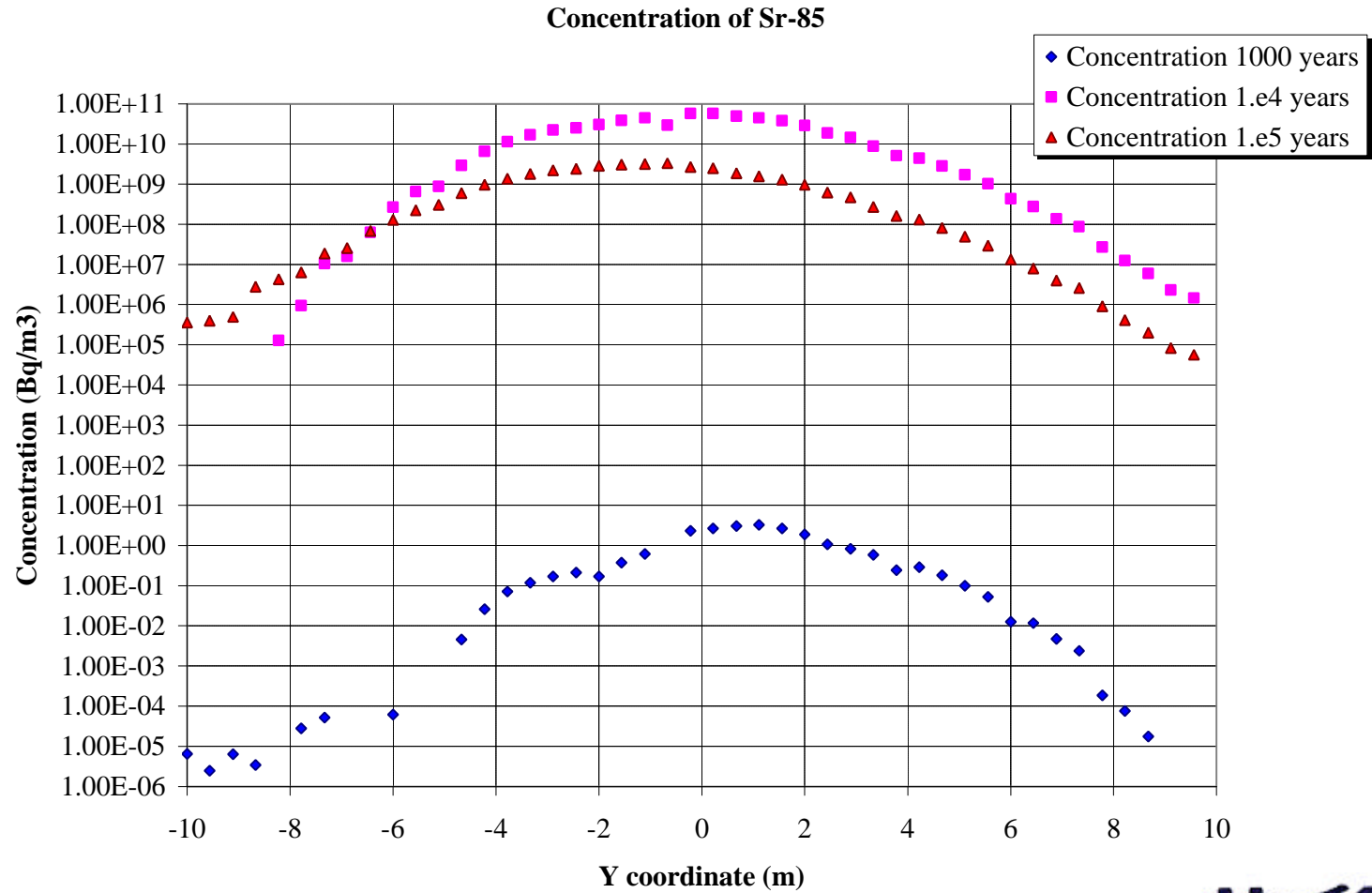
# Sr-85 Tracer Breakthrough

Sr-85 Cumulative Recovery





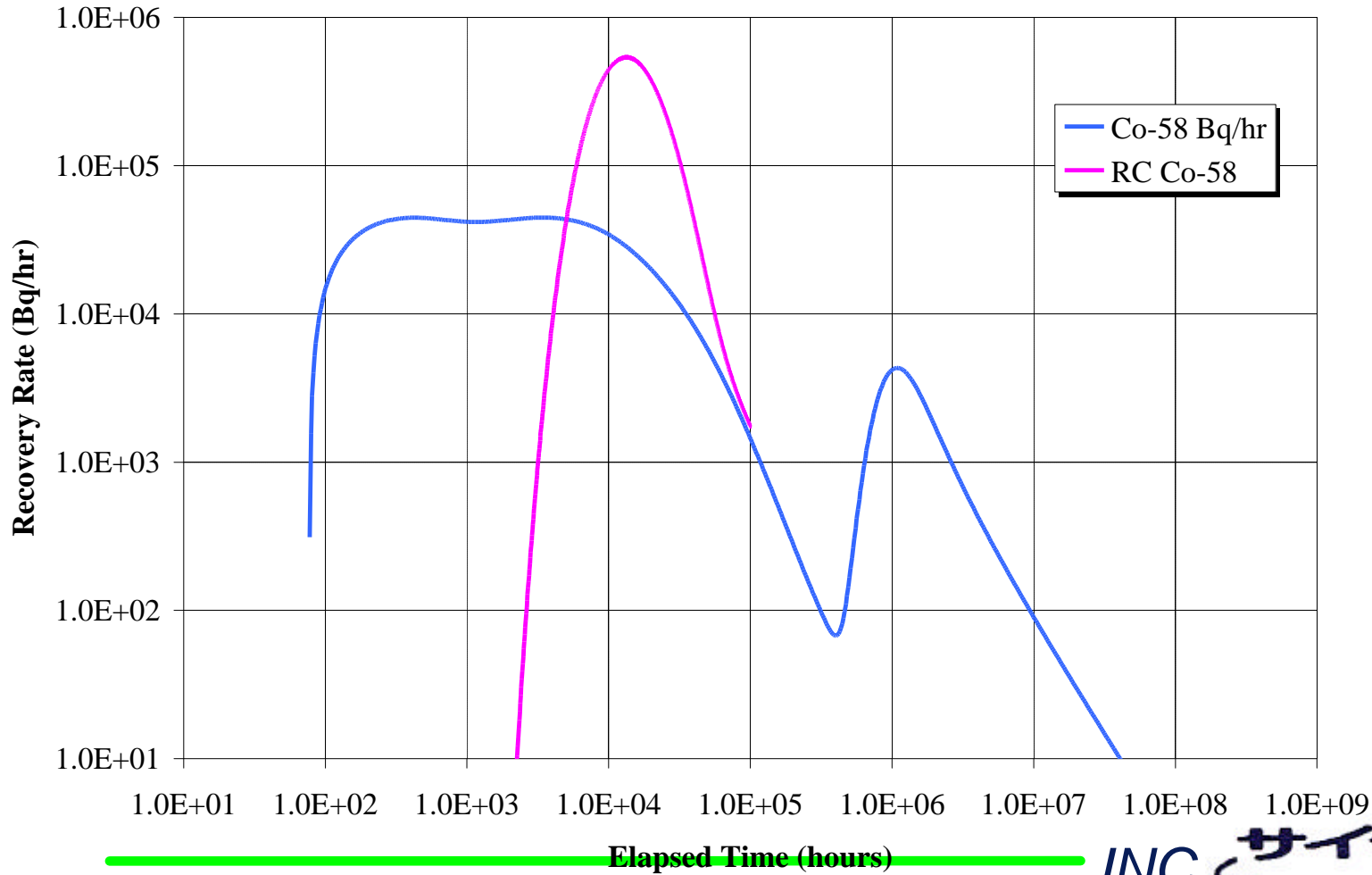
# Sr-85 Tracer Breakthrough



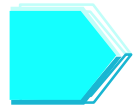


# Co-58 Tracer Breakthrough

Co-58 Recovery Rate

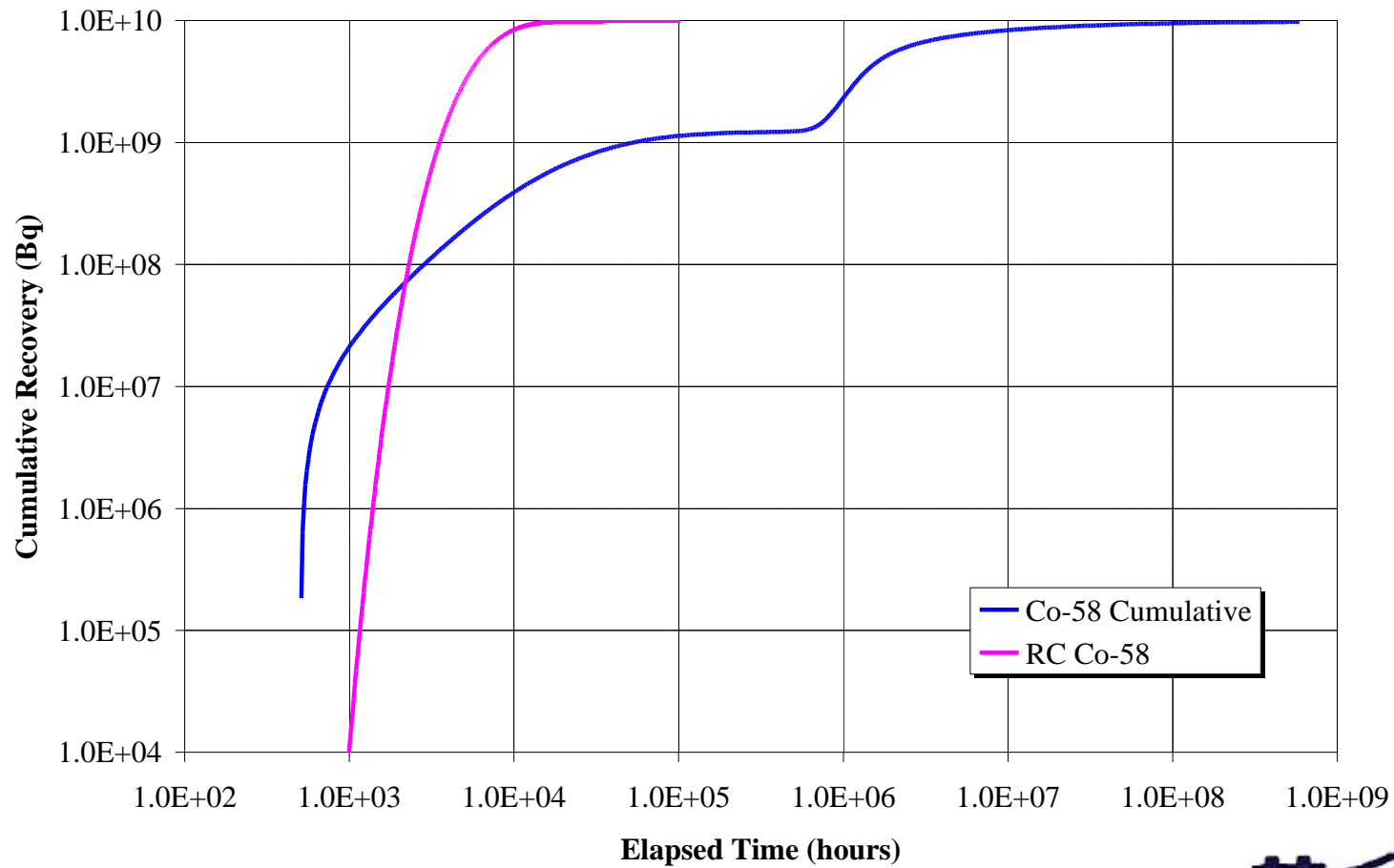


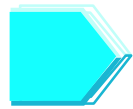
923 1089.H13



# Co-58 Tracer Breakthrough

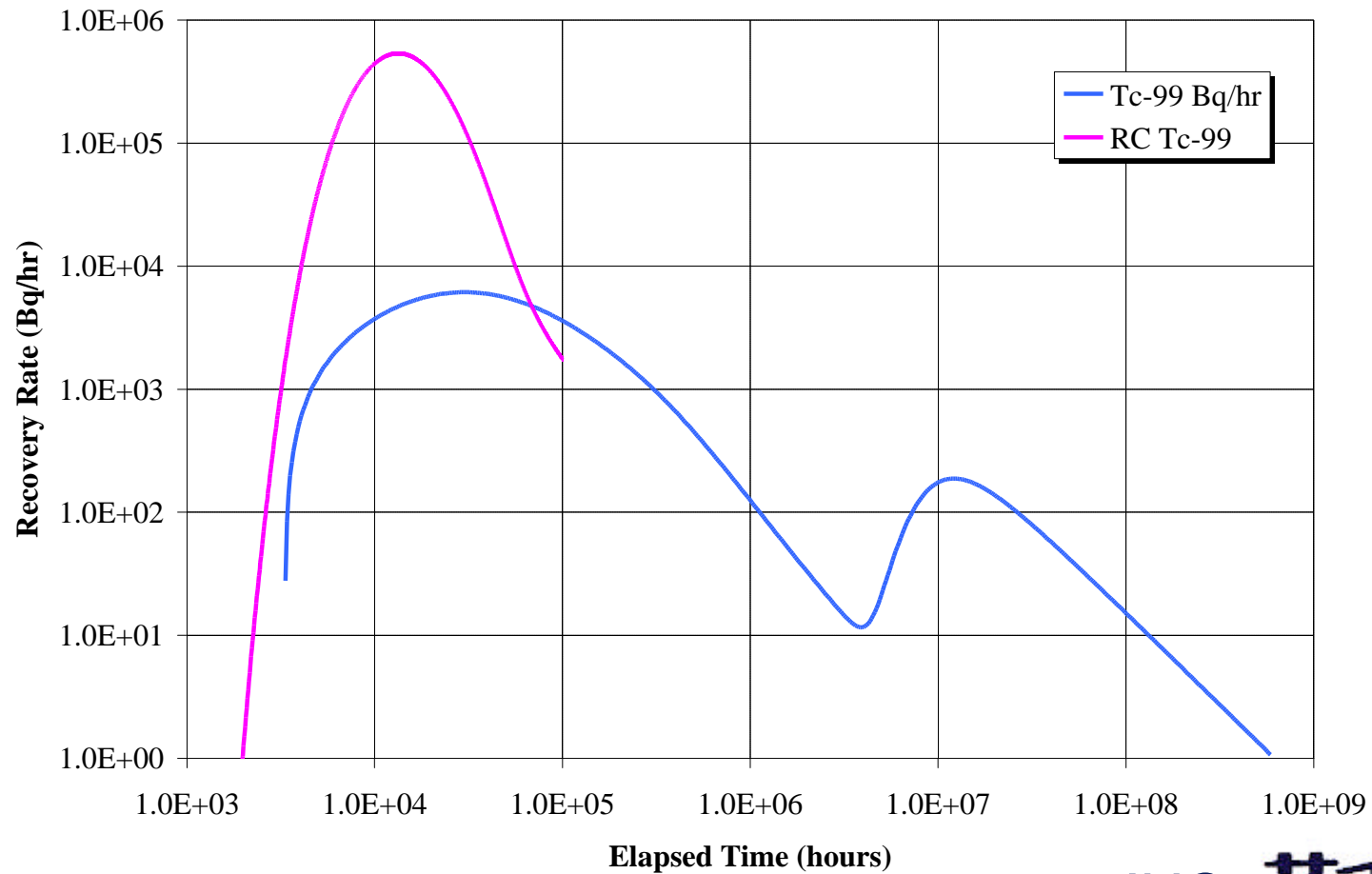
Co-58 Cumulative Recovery



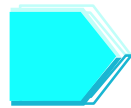


# Tc-99 Tracer Breakthrough

Tc-99 Recovery Rate

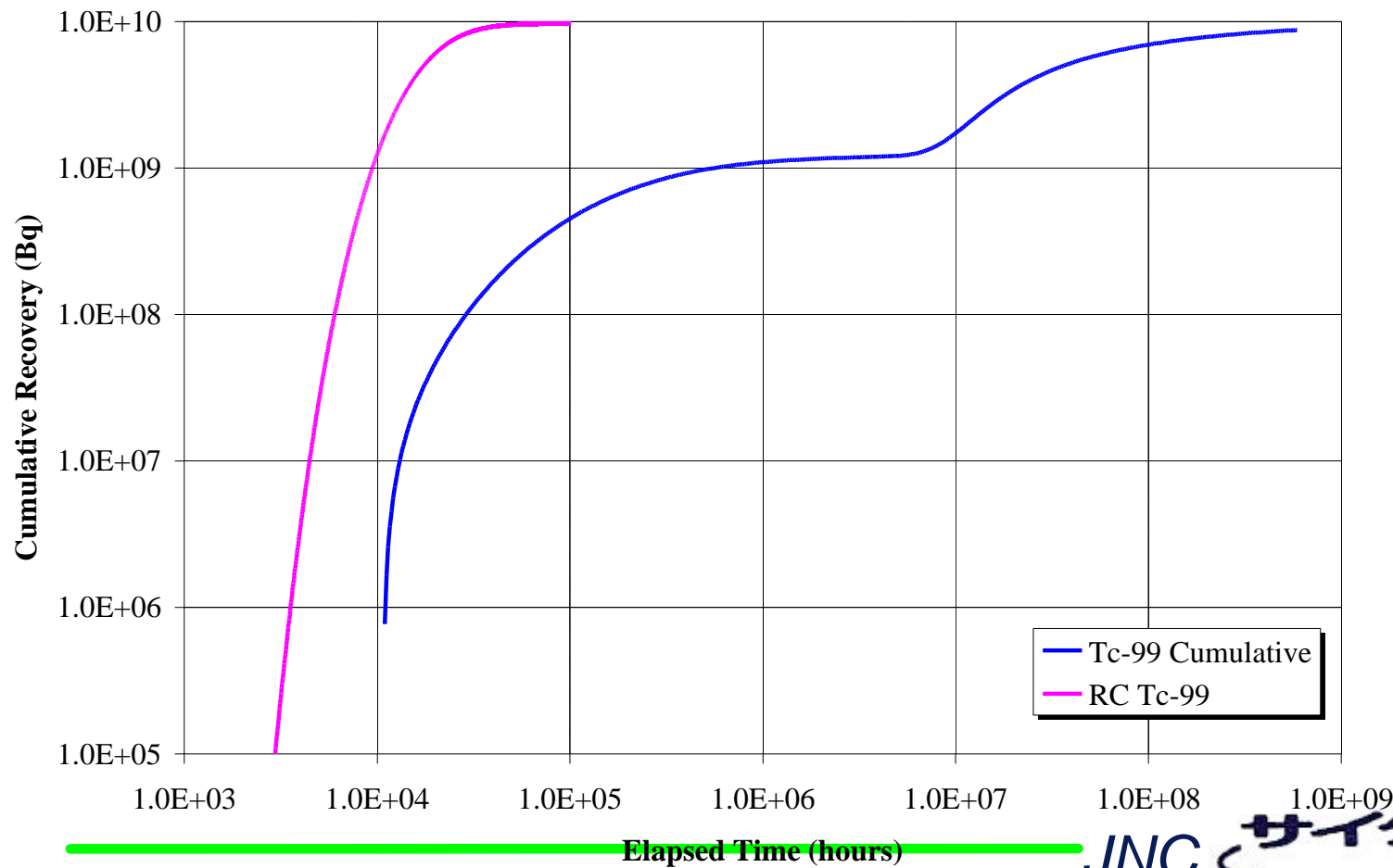






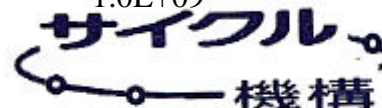
# Tc-99 Tracer Breakthrough

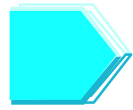
Tc-99 Cumulative Recovery



923 1089.H13

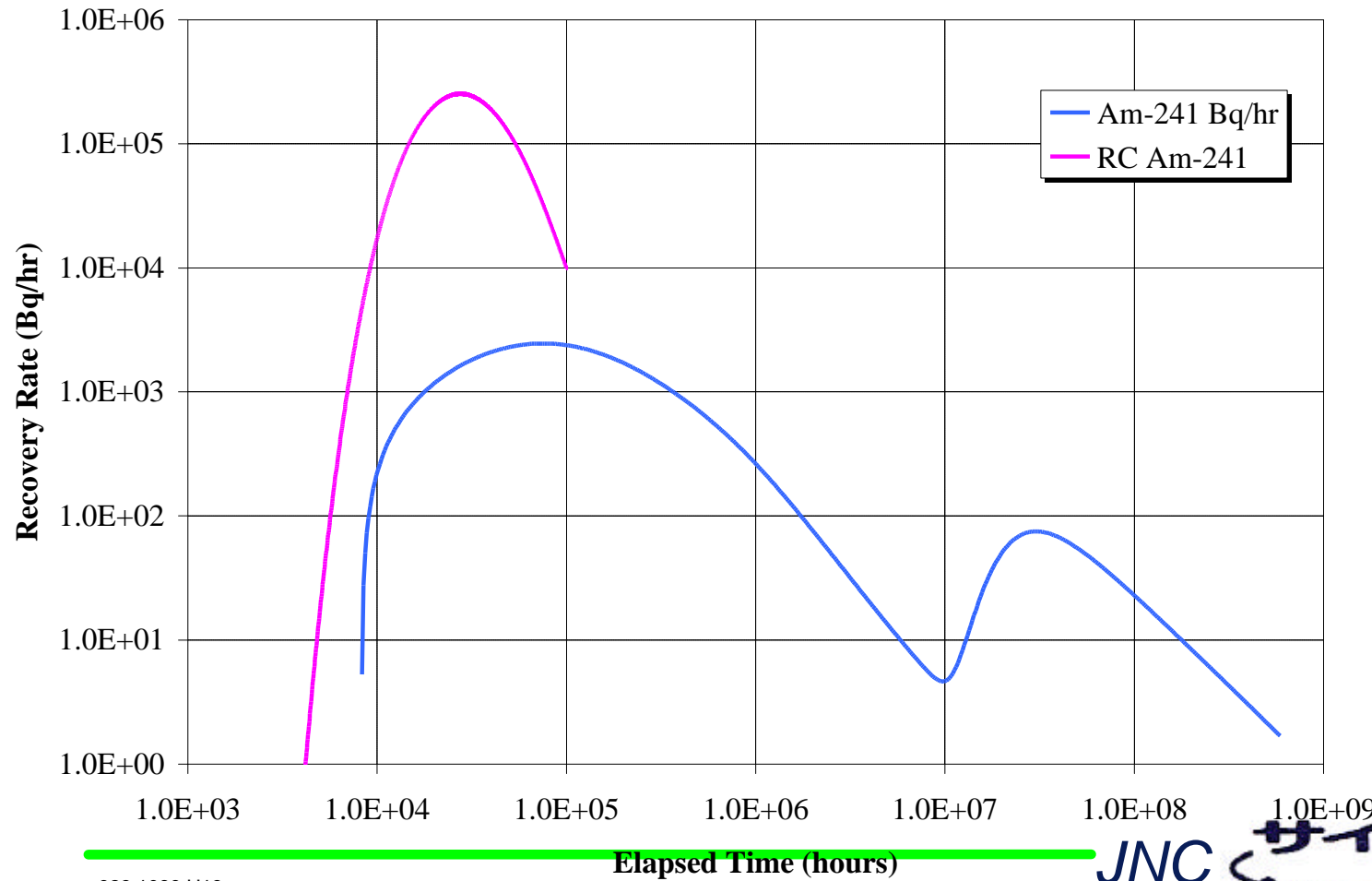
JNC





# Am-241 Tracer Breakthrough

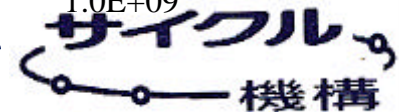
Am-241 Recovery Rate

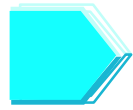


923 1089.H13

Elapsed Time (hours)

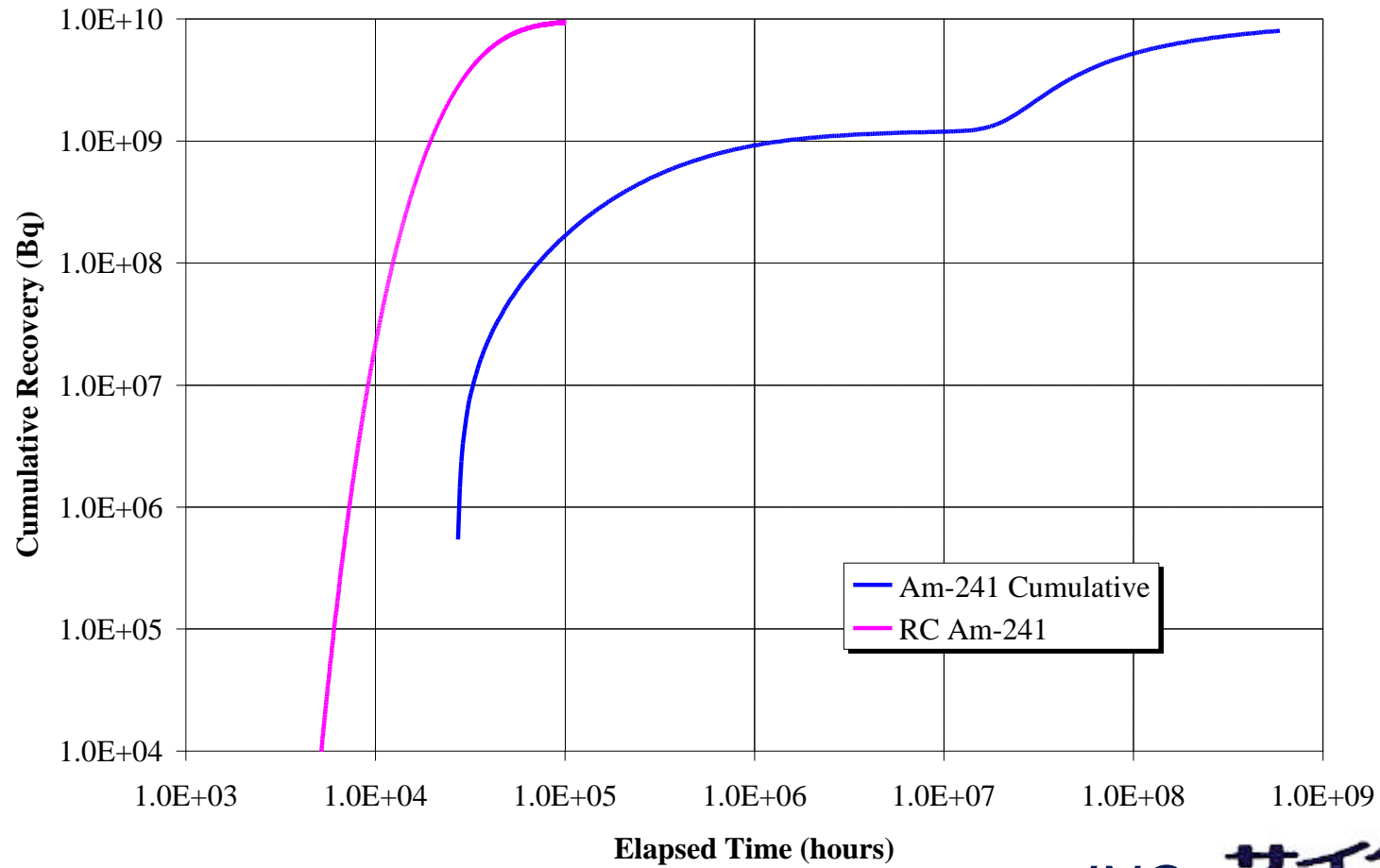
JNC

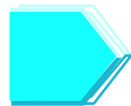




# Am-241 Tracer Breakthrough

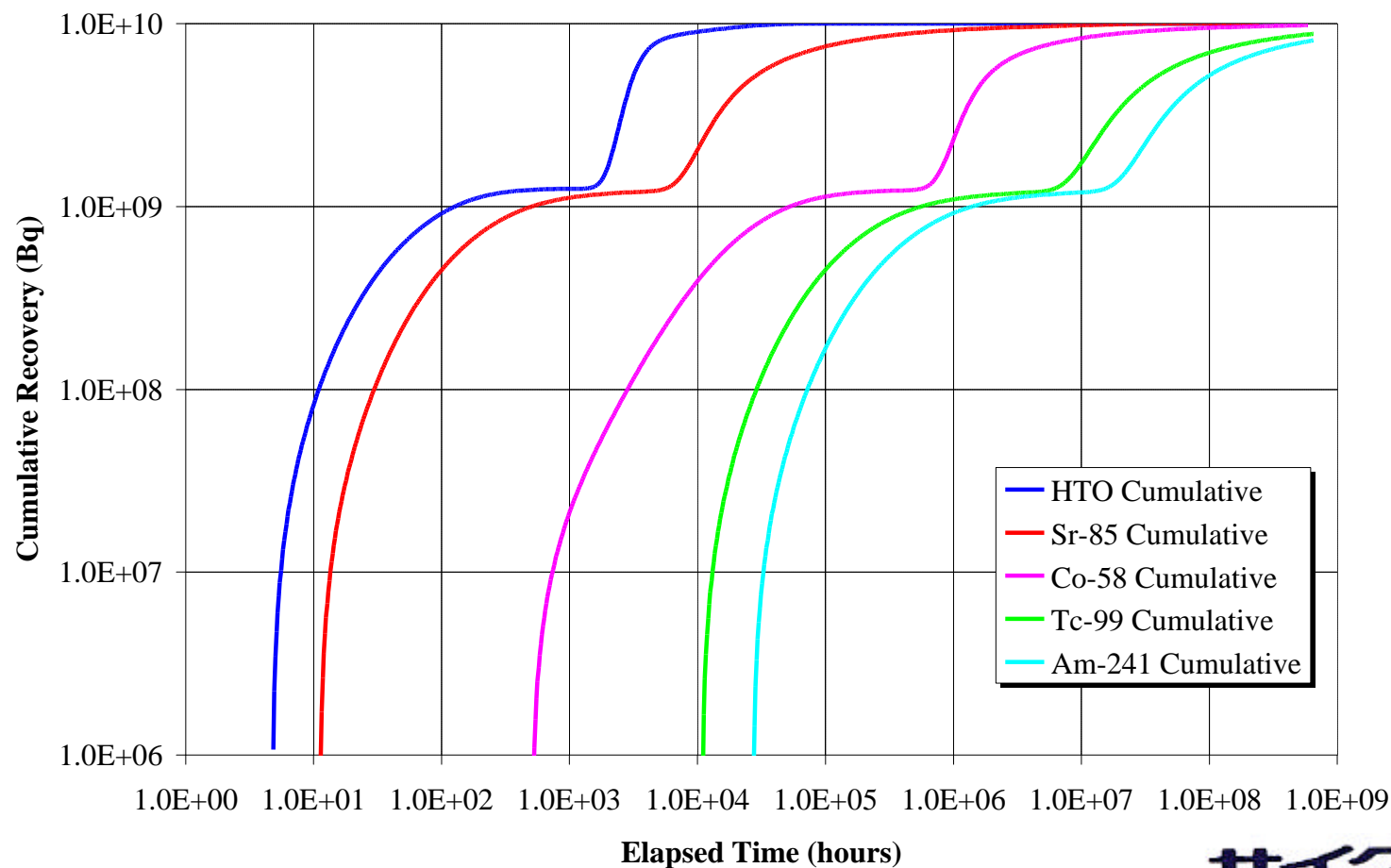
Am-241 Cumulative Recovery





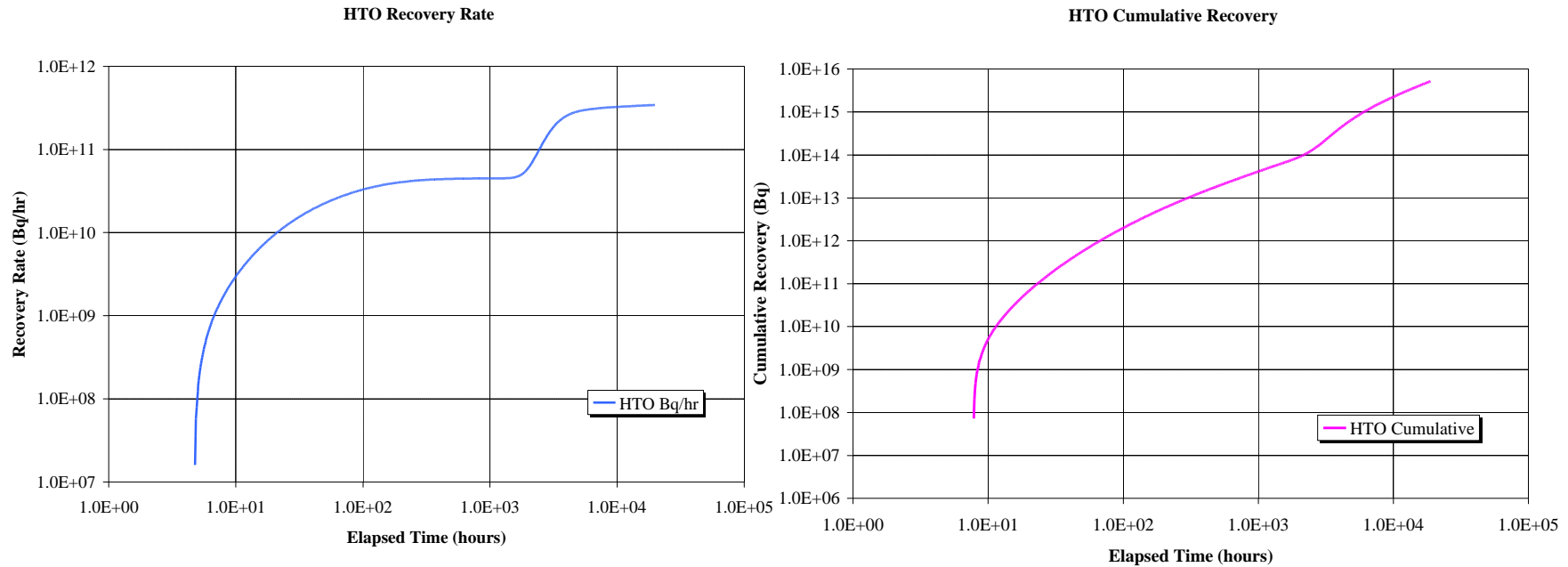
# Dirac Tracer Breakthrough

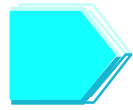
Cumulative Recovery





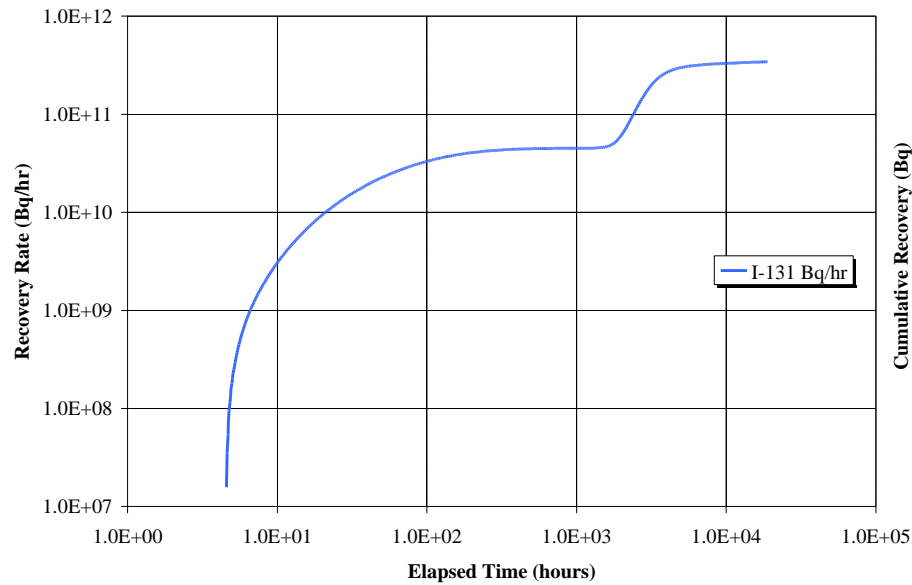
# Continuous Release HTO



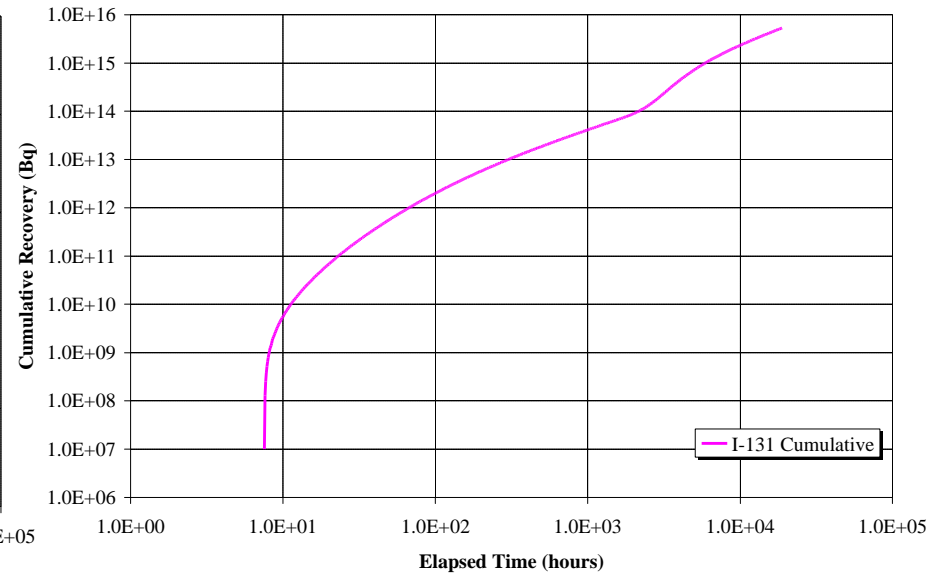


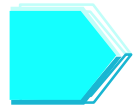
# Continuous Release I-131

I-131 Recovery Rate



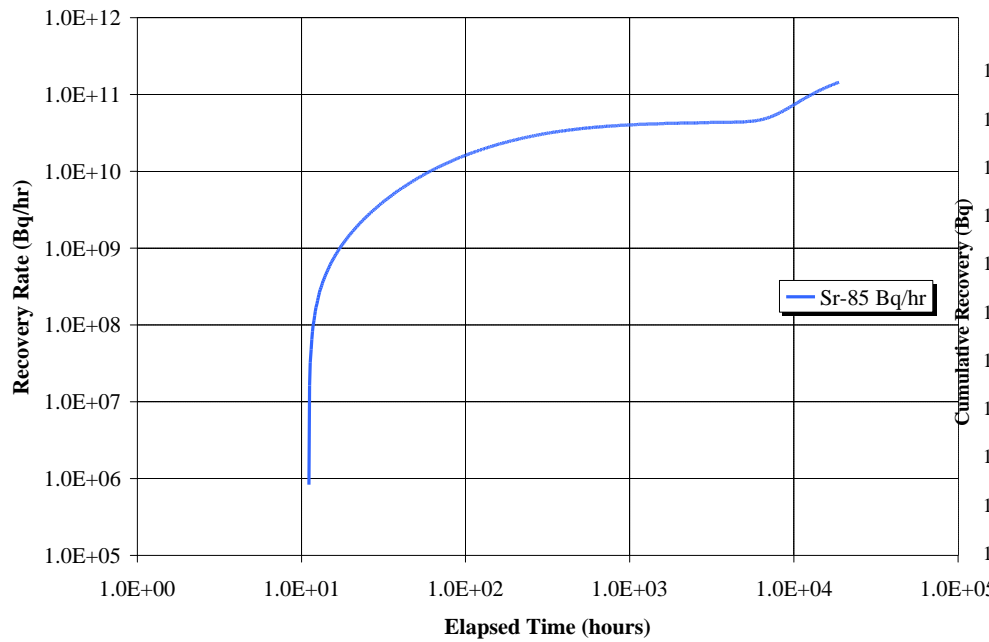
I-131 Cumulative Recovery



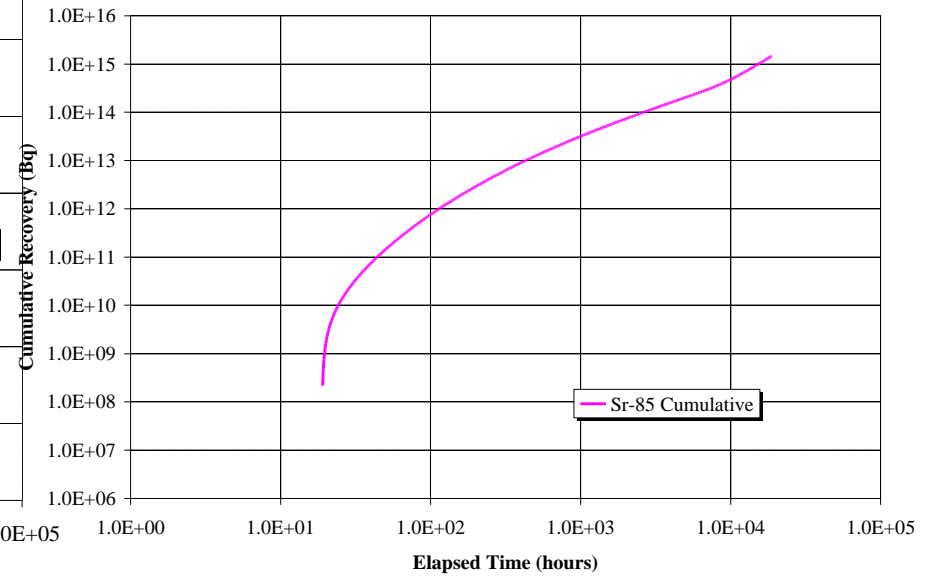


# Continuous Release Sr-85

Sr-85 Recovery Rate



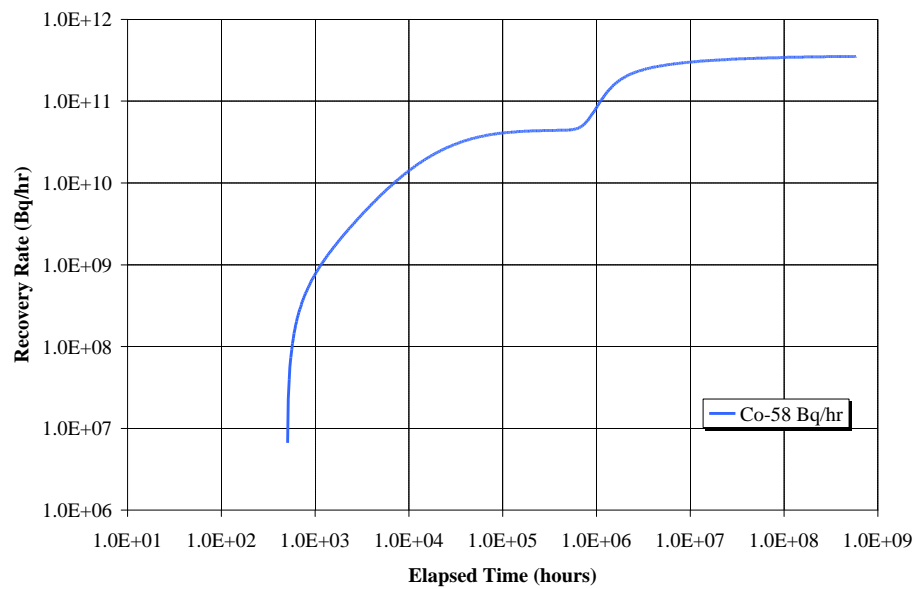
Sr-85 Cumulative Recovery



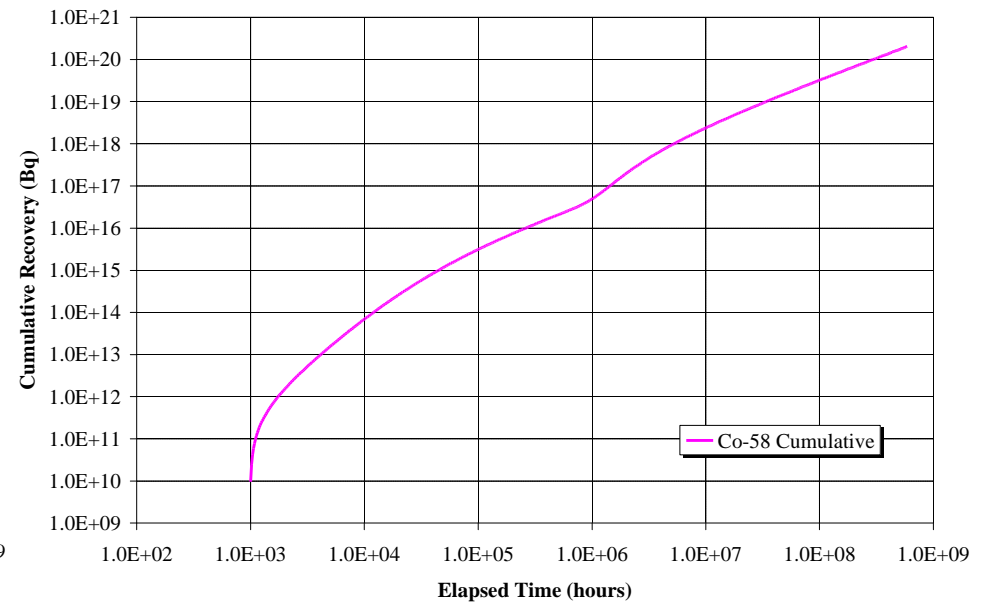


# Continuous Release Co-58

Co-58 Recovery Rate



Co-58 Cumulative Recovery

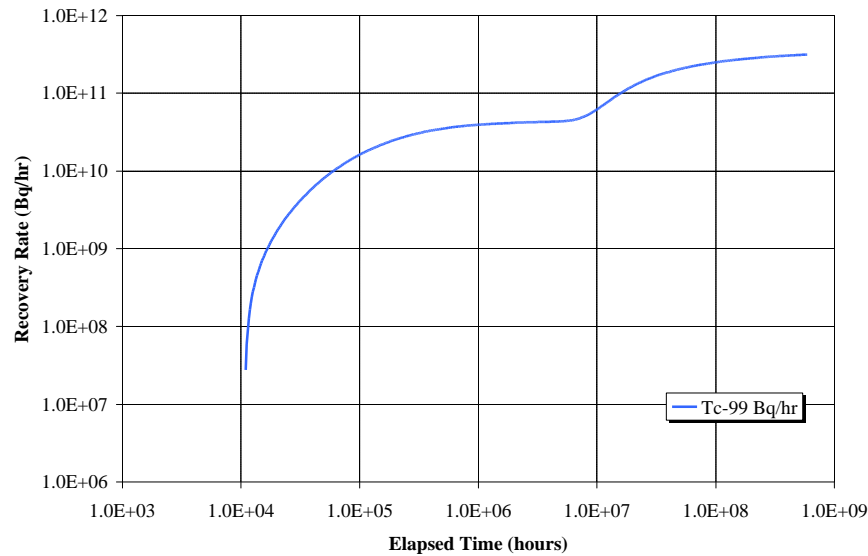




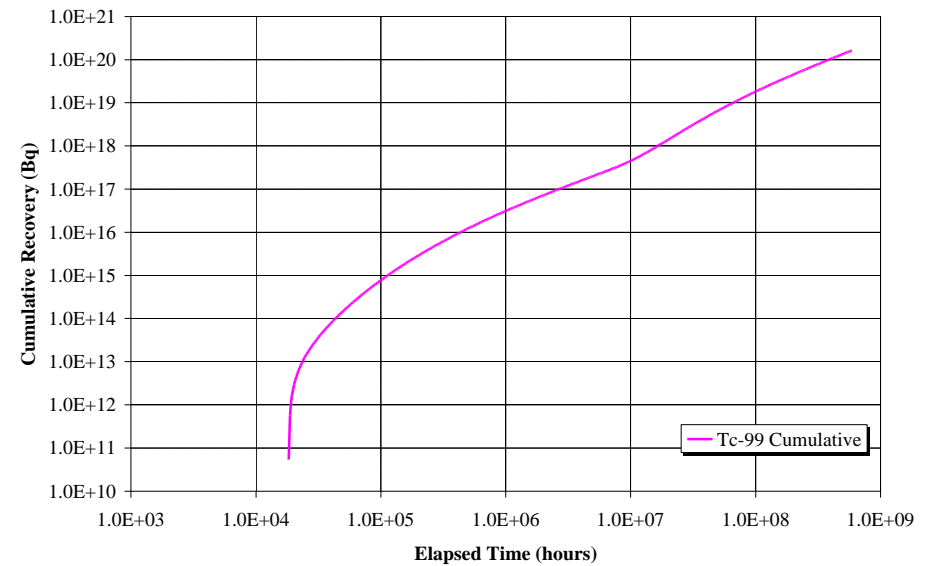


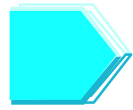
# Continuous Release Tc-99

Tc-99 Recovery Rate



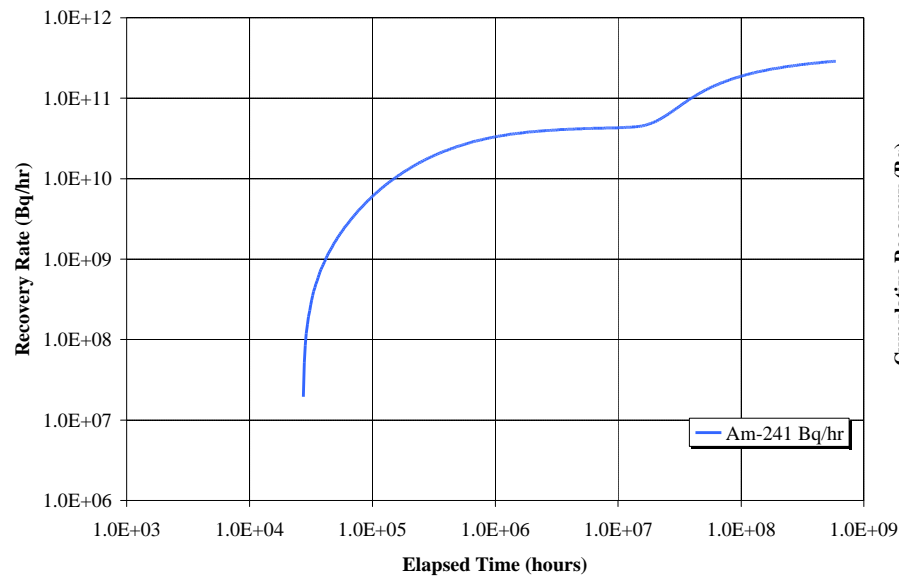
Tc-99 Cumulative Recovery



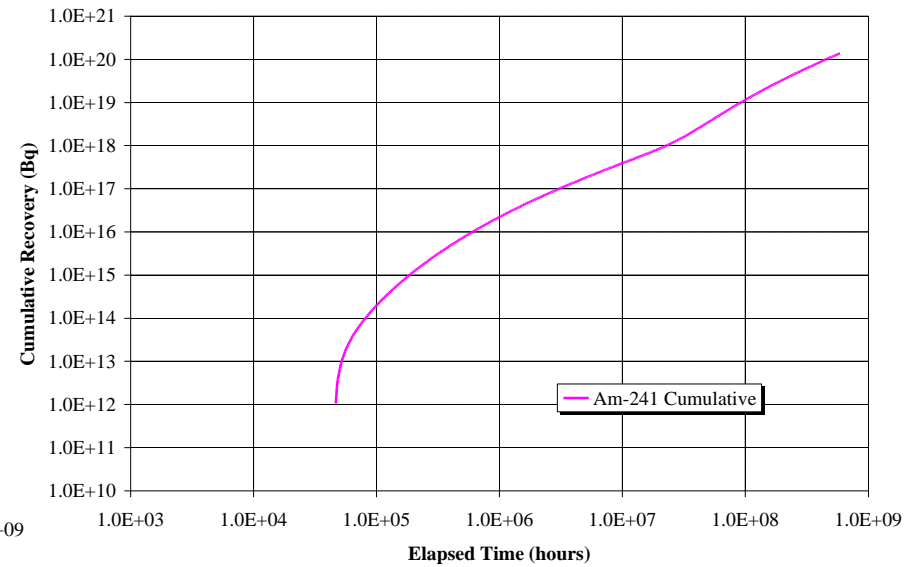


# Continuous Release Am-241

Am-241 Recovery Rate



Am-241 Cumulative Recovery



## Conclusions

- **More Realistic Boundary Conditions Significantly Effect the Shape of Breakthrough, including Effective Retardation and Effective Dispersion**
- **PAWorks/LTG Fracture Network “Site Characterisation” Code **can use/requires** significantly more information than 1-D GoldSim PA Approach**
  - **Heterogenous Transmissivity/Aperture Field**
  - **Detailed Head Field and Boundary Conditions**
  - **Spatial Pattern of Immobile Zones**
- **Computation Times for PAWorks/LTG are much larger those of GoldSim, but still solves within CPU minutes.**

## Appendix N

Modeling of T6A&B  
A. Poteri (VTT/POSIVA)



# Modelling of the Task 6

Antti Poteri  
VTT Energy



# Task 6A

- ◆ Modelled processes:
  - Advection
  - Sorption
  - Matrix diffusion
- ◆ Geological units taken into account
  - Flow field / stagnant pools
  - Fault gouge
  - Rock matrix
- ◆ Measured BTC for I-131, Sr-85 and Co-60
- ◆ Measured STT-1b BTC used to “calibrate” the model

# Modelling approach

- ◆ Single flow path
  - always 100% recovery in the model
  - applied estimated recoveries for I (100%), Sr (87%) and Co (44%)
- ◆ Analytical model
  - penetration depth estimated using Monte-Carlo simulations
- ◆ Tracer discharge (Dirac pulse injection):

$$\frac{\dot{m}}{m_0} = H(t - R_a t_w) \frac{u}{\sqrt{p} (t - R_a t_w)^{3/2}} e^{-\frac{u^2}{t - R_a t_w}}$$

where  $u = \frac{D_e x}{v 2b} \sqrt{\frac{R_p}{D_p}} = \sqrt{D_e e R_p} \frac{t_w}{2b} = \sqrt{D_e e R_p} \frac{W x}{Q}$



# Monte-Carlo simulations

- ◆ Approach:
  - 1D random walk, fixed time step
  - $-b < z < 0$  fracture,  $z > 0$  matrix
  - Random walk until the time spend in the fracture reach  $t_w$
- ◆ Penetration depth
  - Boundary in the matrix changes the breakthrough curve towards more symmetric and sharper peak

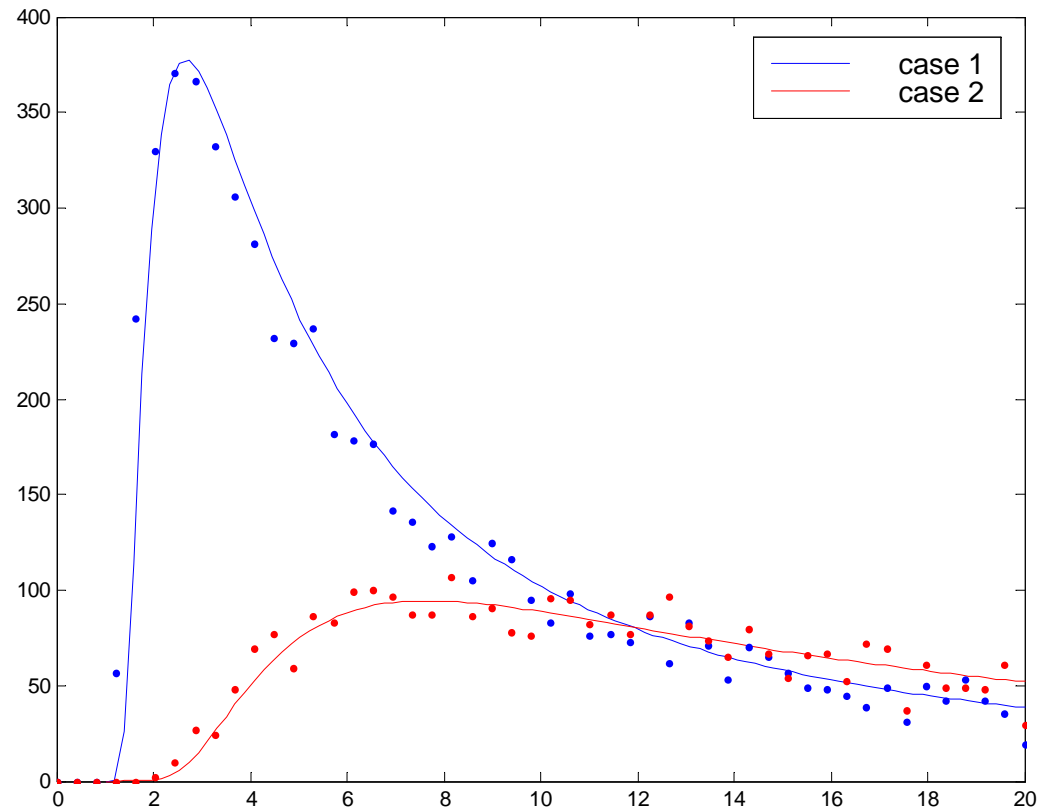
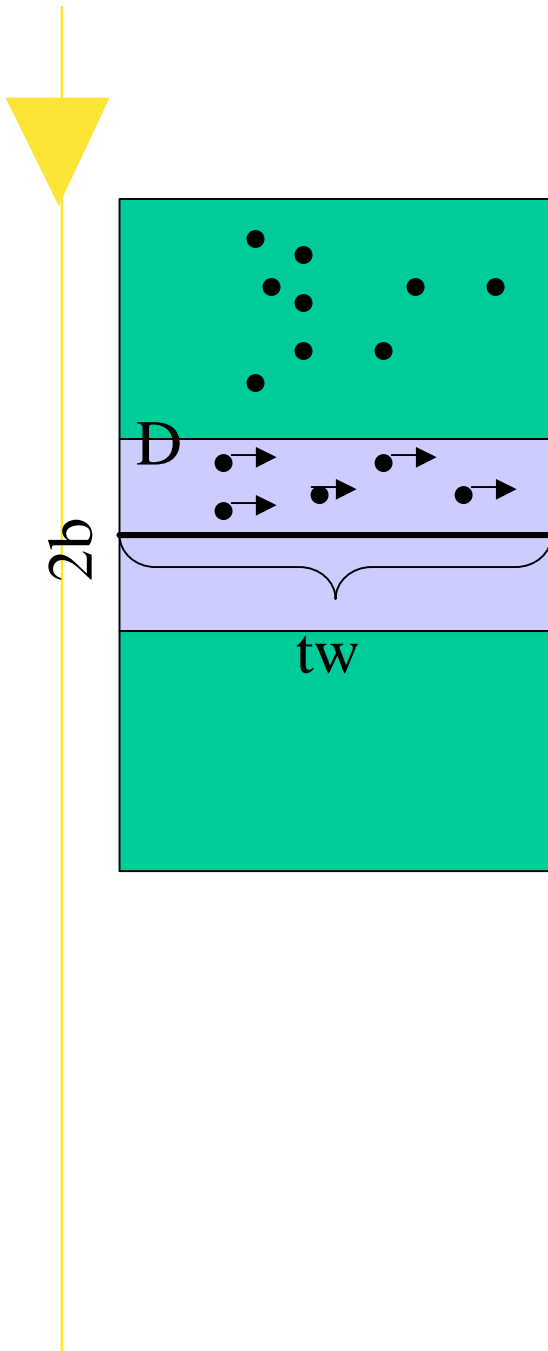


# Monte-Carlo simulations

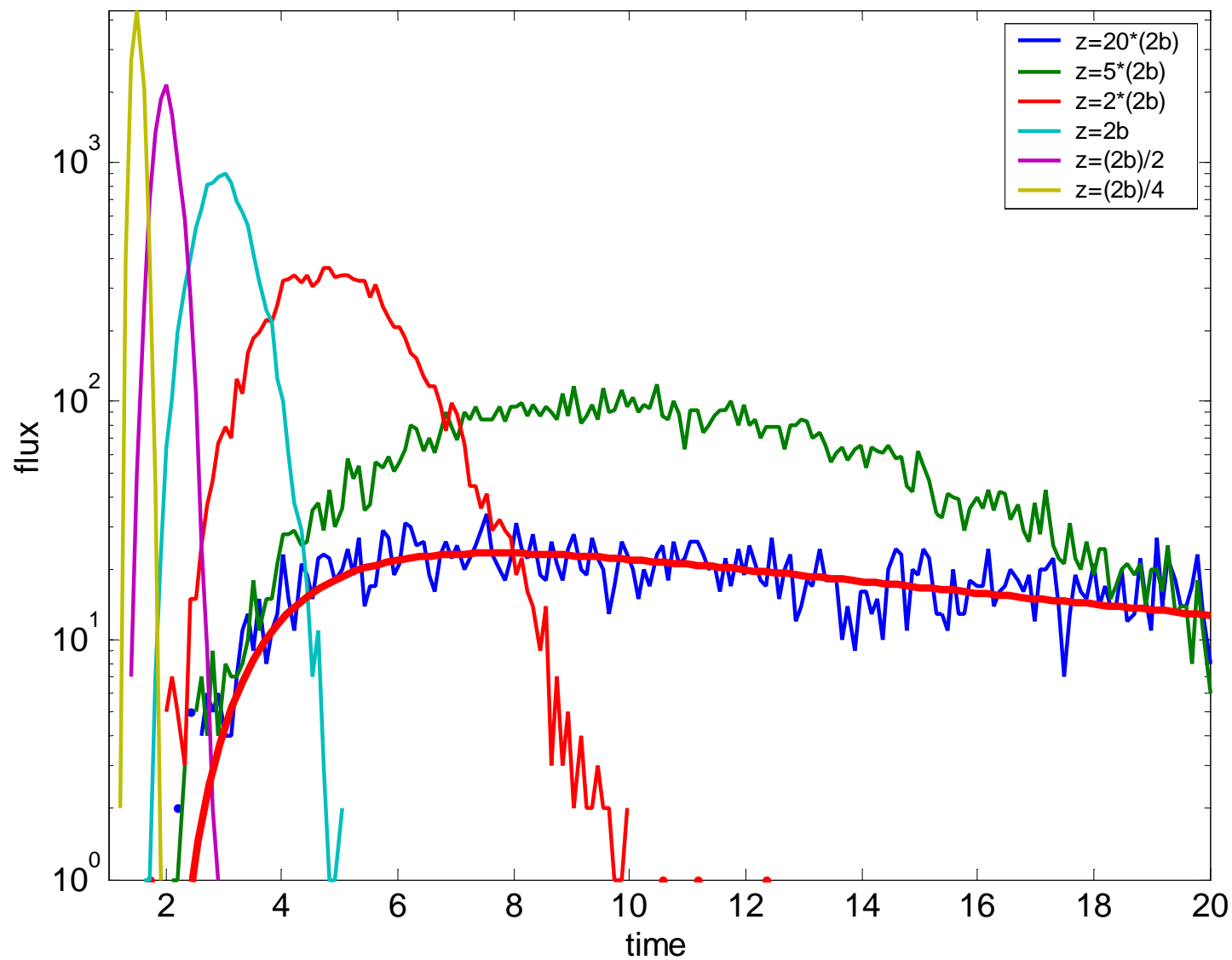
Dots: M-C Simulation results

Lines:  $\frac{\dot{m}}{m_0} = H(t - R_a t_w) \frac{u}{\sqrt{p} (t - R_a t_w)^{3/2}} e^{-\frac{u^2}{t - R_a t_w}}$

using  $u = \sqrt{D} \frac{t_w}{2b}$



# Limited matrix diffusion





# Matrix diffusion parameter

- ◆ ~“Ratio of the mean time spent in the matrix to mean time spent in the fracture”

$$U = \sqrt{D_e \mathbf{e} \frac{R_p}{R_a} t_w} \frac{1}{b} \Rightarrow u = U \frac{\sqrt{R_a t_w}}{2}$$

# Task 6, sorption parameters

Flow field & stagnant pools	Ka	2b [m]	STAGNANT Ra
I	0	2.00E-03	1
Sr	8.00E-06	2.00E-03	1.008
Co	0.008	2.00E-03	9
Tc	0.2	2.00E-03	201
Am	0.5	2.00E-03	501

Gouge: Kd and Ka same as for the rock matrix, except Kd(Co)*10 and Kd(Sr)*10	Ka	Kd	Rock rho_s	Rock eps_s	Gouge eps_g	Gouge rho_g	2b [m]	GOUGE Ra	Rp
I	0	0	2700	0.004	0.03	2630	2.00E-03	1	1
Sr	8.00E-06	4.70E-05	2700	0.004	0.03	2630	2.00E-03	1.008	5
Co	0.008	0.008	2700	0.004	0.03	2630	2.00E-03	9	681
Tc	0.2	0.2	2700	0.004	0.03	2630	2.00E-03	201	17005
Am	0.5	0.5	2700	0.004	0.03	2630	2.00E-03	501	42512

	Ka	Kd	Rock rho_s	Rock eps_s	2b [m]	Rock Ra	Rp
I	0	0	2700	0.004	2.00E-03	1	1
Sr	8.00E-06	4.70E-06	2700	0.004	2.00E-03	1.008	4.16
Co	0.008	0.0008	2700	0.004	2.00E-03	9	539
Tc	0.2	0.2	2700	0.004	2.00E-03	201	134461
Am	0.5	0.5	2700	0.004	2.00E-03	501	336151

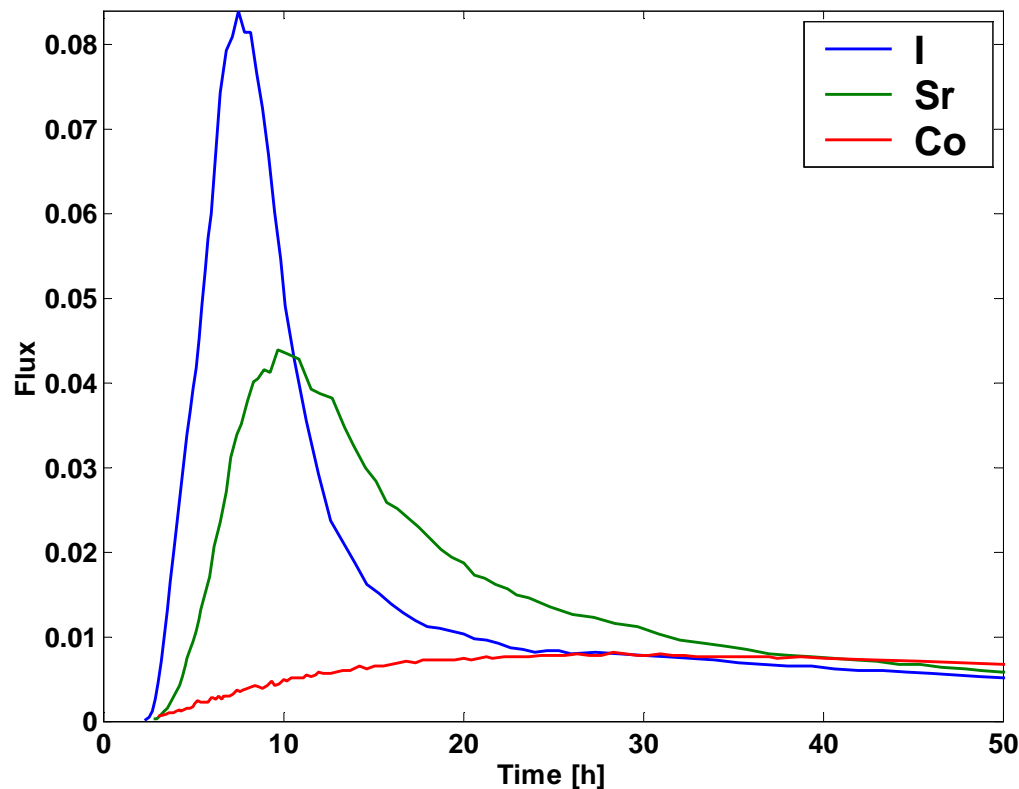
# STT-1b: I-131, Sr-85, Co-60

## Scaled breakthrough curves

STT-1b measured breakthrough curves

Sr scaled by 1.1, Co scaled by 9.0

$$U = \sqrt{D_e e \frac{R_p}{R_a} t_w \frac{1}{b}}$$



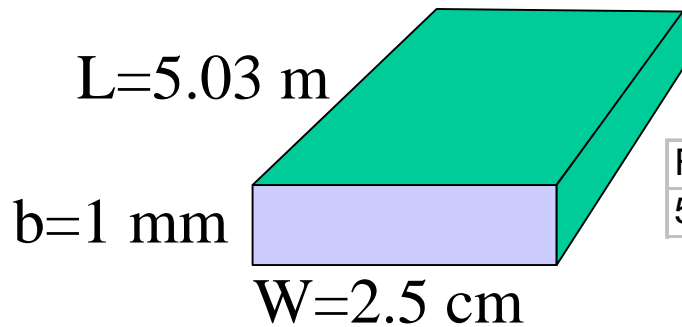
Scaled breakthrough curves:

->  $R_p > R_a$  for Sr and Co

-> Stagnant pools alone cannot explain Sr and Co

-> Use fault gouge for the calibration

# Flow path



Flow rate	Width	Aperture	Length	Av. velocity	Transit time
58 ml/h	2.5 cm	2 mm	5.03 m	1.16 m/h	4.34 h

$$U_{\text{stag}} = \sqrt{Dw G \epsilon^2 t w} * 2 / (2W)$$

$$U_{\text{gouge}} = \sqrt{Dw G \epsilon^2 R_p / R_a t w} * 2 / (2e), e = \text{distance between gouge particles in fracture} = 4e-5 \text{ m}$$

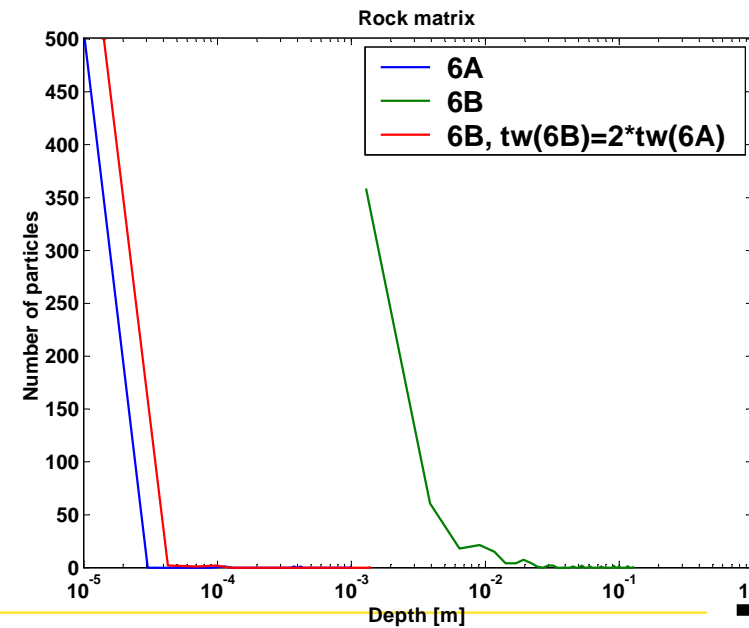
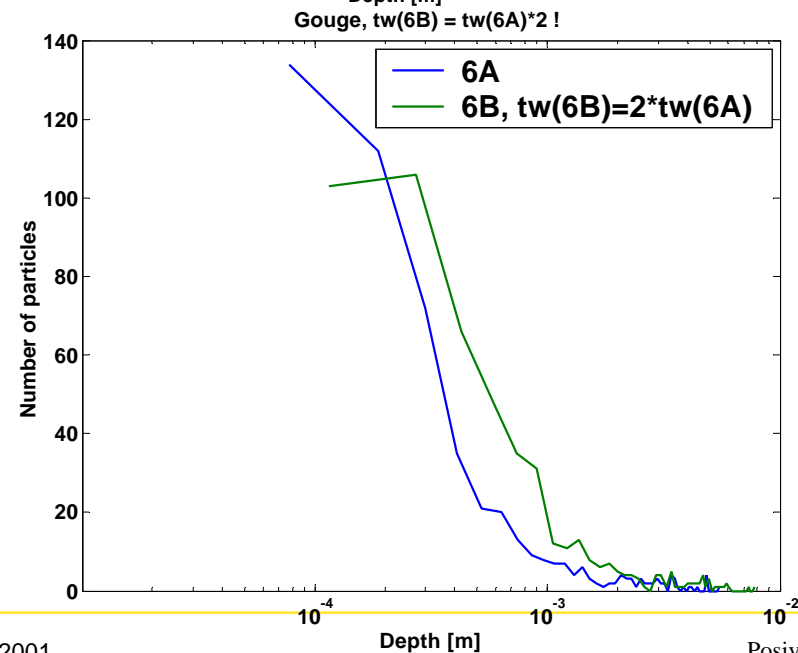
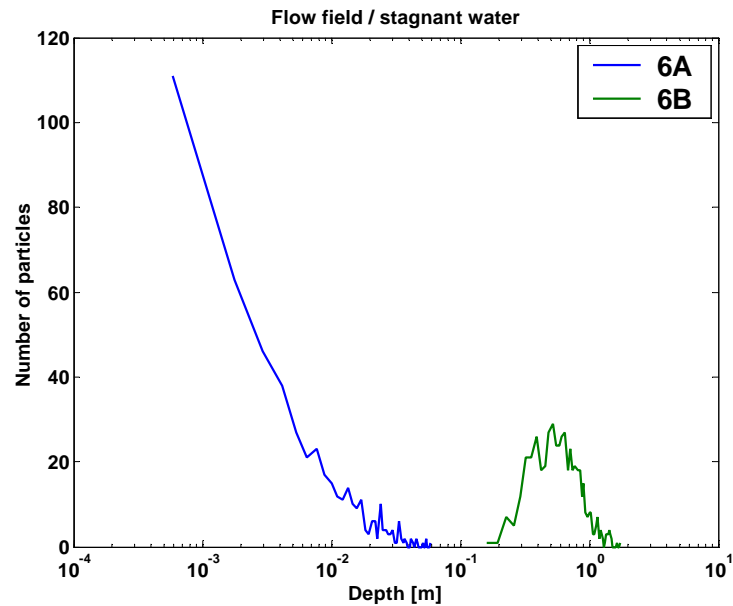
$$U_{\text{rock}} = \sqrt{Dw G \epsilon^2 R_p / R_a t w} * 2 / (2b)$$

Task 6A	$U_{\text{stag}}$	$U_{\text{gouge}}$	$U_{\text{rock}}$	$U_{\text{tot}}$
<b>I-131</b>	0.49	0.52	0.01	1.02
<b>Sr-85</b>	0.49	1.16	0.02	1.67
<b>Co-60</b>	0.49	4.53	0.08	5.10
<b>Tc-99m</b>	0.49	4.79	0.27	5.55
<b>Am-241</b>	0.49	4.79	0.27	5.55

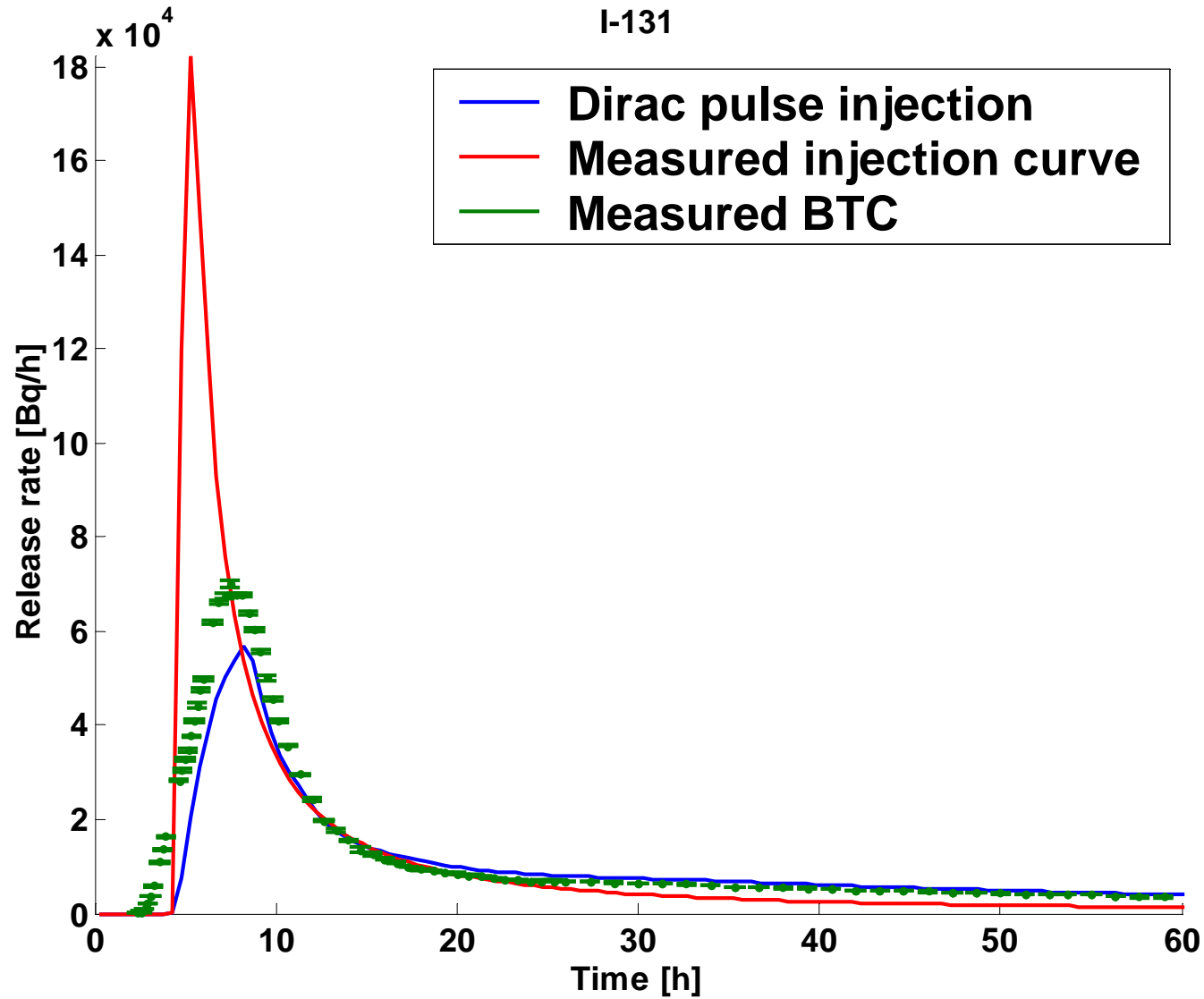
Task 6B	$U_{\text{stag}}$	$U_{\text{gouge}}$	$U_{\text{rock}}$
<b>I-131</b>	15.48	16.46	0.09
<b>Sr-85</b>	15.55	36.65	0.18
<b>Co-60</b>	46.45	143.20	0.68
<b>Tc-99m</b>	219.53	151.40	2.27
<b>Am-241</b>	346.59	151.63	2.27

# Penetration depth of the matrix diffusion

Monte-Carlo simulation  
Maximum depth visited in the matrix  
~500 particles

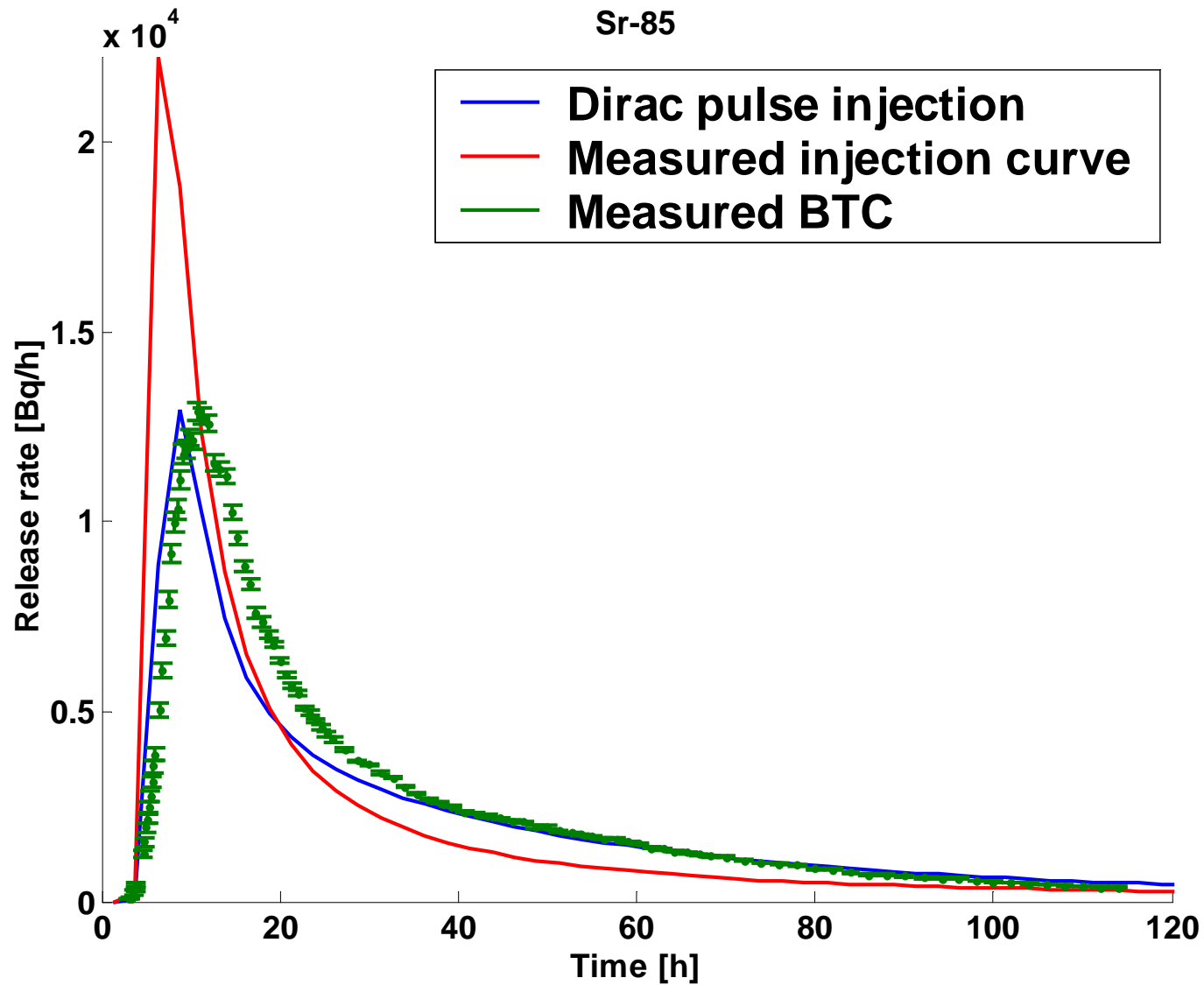


# Task 6A, breakthrough curves 1/5



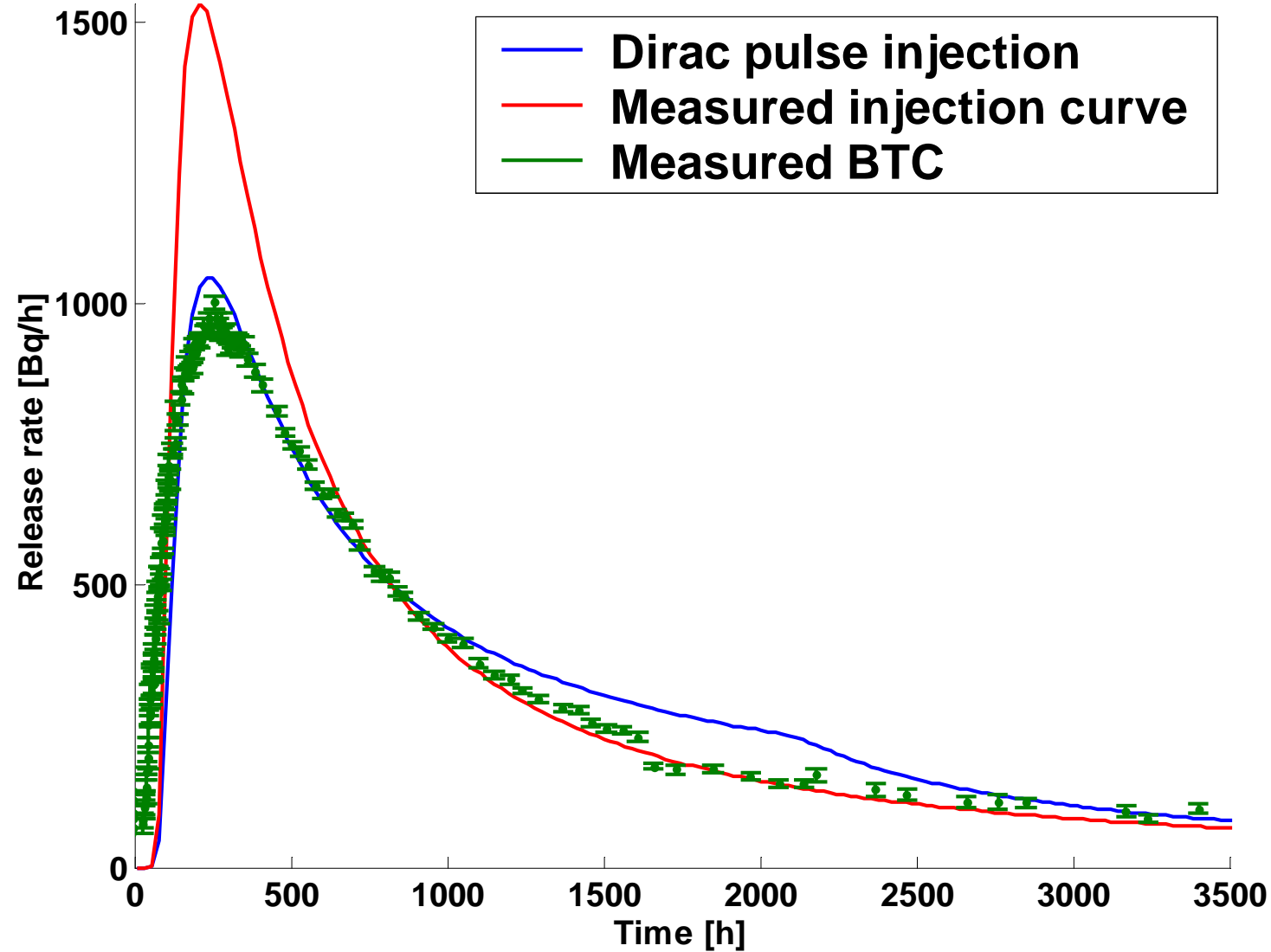


# Task 6A, breakthrough curves 2/5

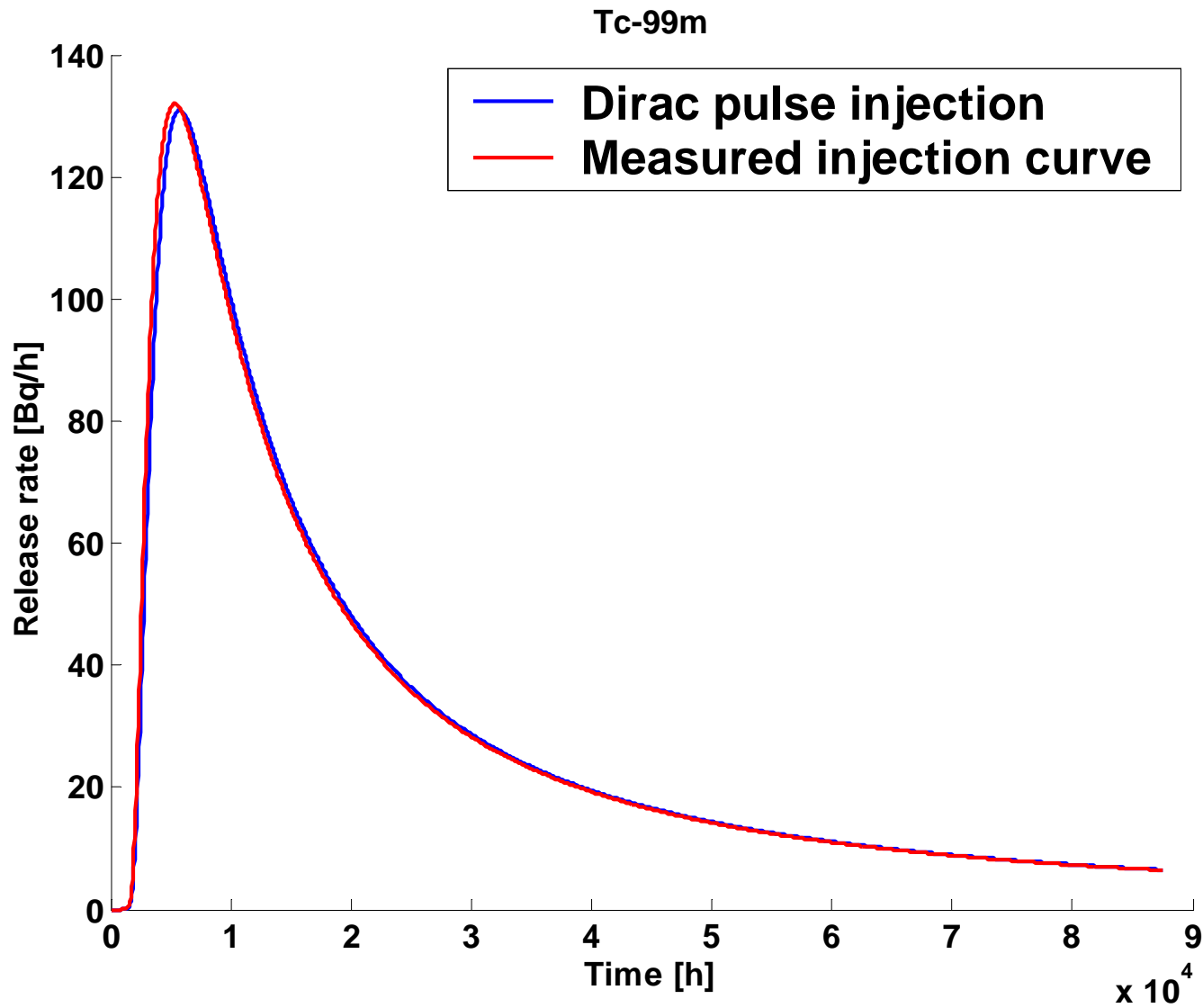


# Task 6A, breakthrough curves 3/5

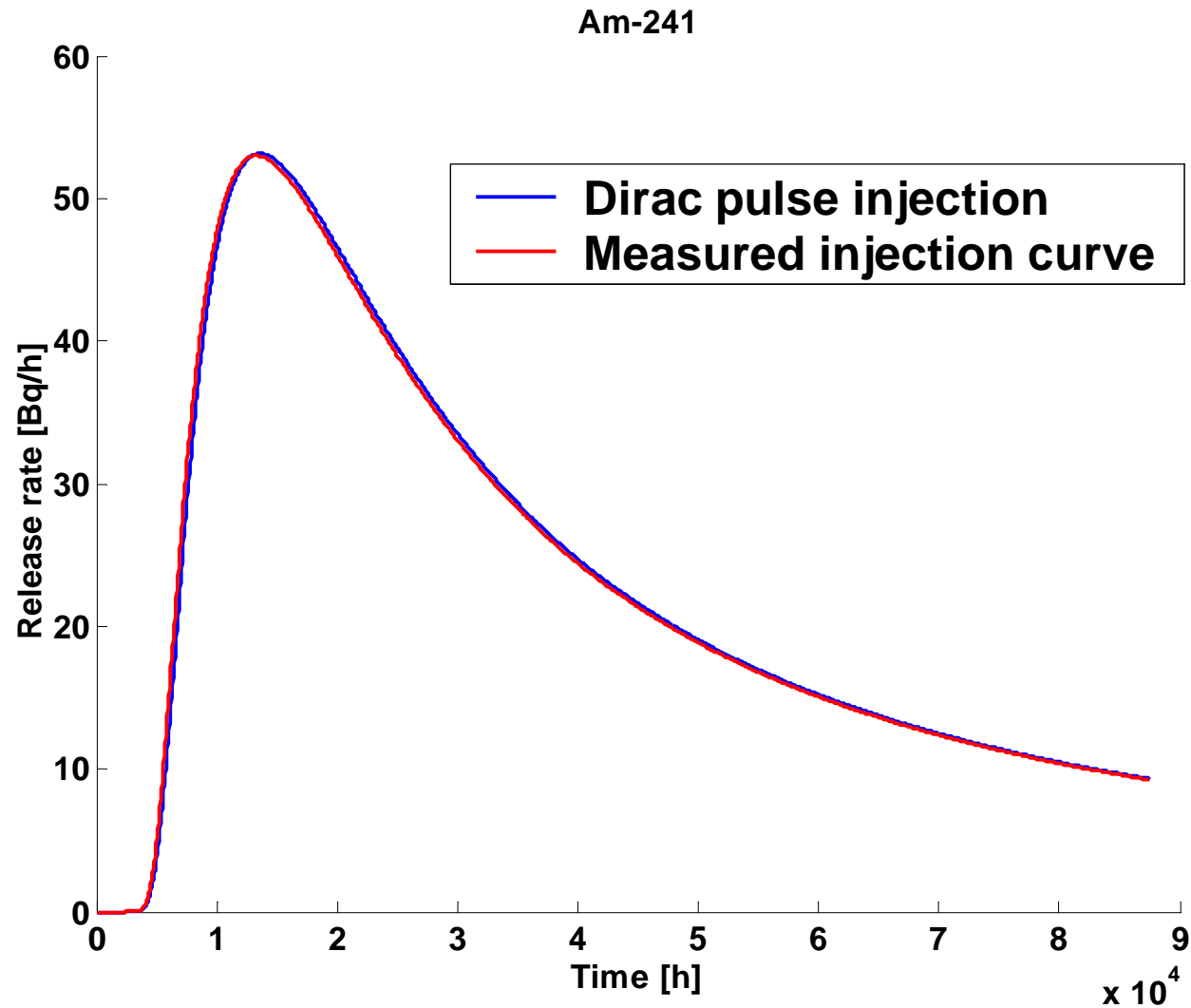
Co-60



# Task 6A, breakthrough curves 4/5



# Task 6A, breakthrough curves 5/5

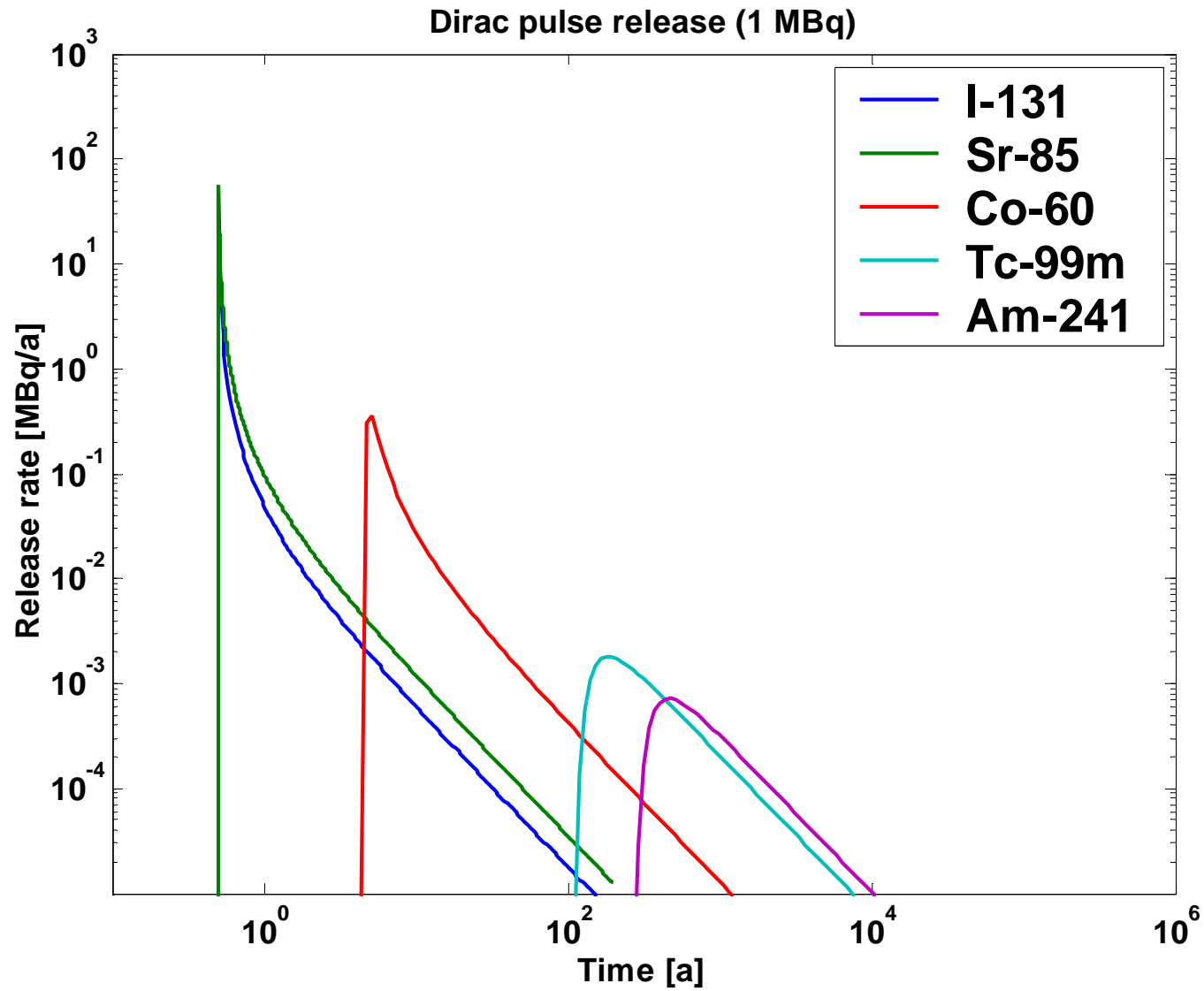


## Task 6A, performance measures

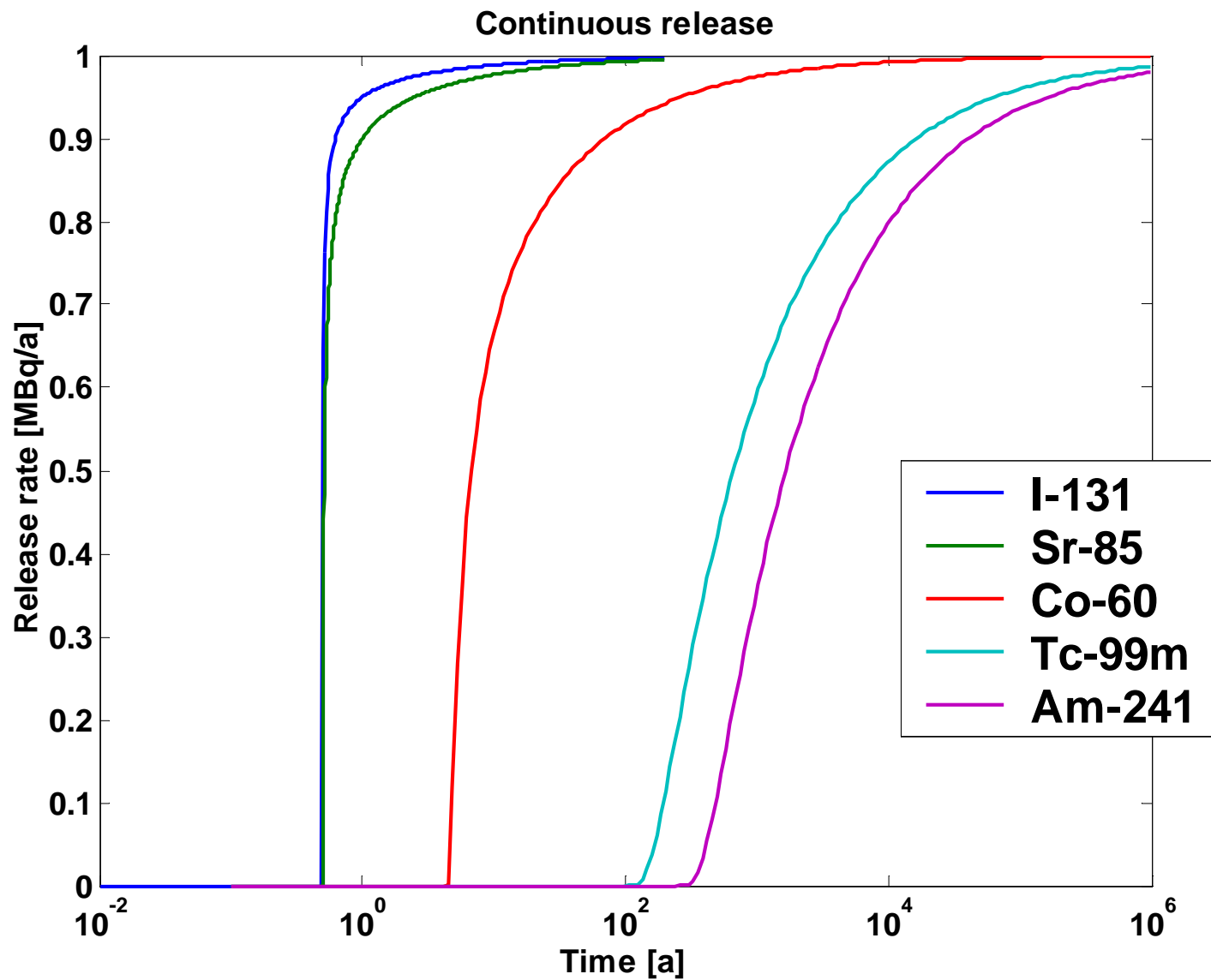
	Maximum release rate [Bq/a]	
	Dirac inj.	Measured inj.
<b>I-131</b>	21.7	6.5
<b>Sr-85</b>	3	1.5
<b>Co-60</b>	0.18	0.12
<b>Tc-99m</b>	0.015	0.015
<b>Am-241</b>	0.0061	0.0061

		Breakthrough times [a]		
		t 5%	t 50%	t 95%
<b>I-131,</b>	<b>Dirac</b>	0.00056	0.0011	0.066
	<b>Meas.</b>	0.00077	0.0033	0.053
<b>Sr-85,</b>	<b>Dirac</b>	0.00068	0.0020	0.18
	<b>Meas.</b>	0.0010	0.0039	0.12
<b>Co-60,</b>	<b>Dirac</b>	0.020	0.13	15
	<b>Meas.</b>	0.024	0.18	>10
<b>Tc-99m,</b>	<b>Dirac</b>	0.50	3.47	390
	<b>Meas.</b>	0.53	3.47	>10
<b>Am-241,</b>	<b>Dirac</b>	1.24	8.65	972
	<b>Meas.</b>	1.27	8.60	>10

# Task 6B, breakthrough curves 1/2



# Task 6B, breakthrough curves 2/2



## Task 6B, performance measures

	Maximum release rate [MBq/a]	
	Dirac inj.	Continuous inj.
<b>I-131</b>	231	1.00
<b>Sr-85</b>	58	1.00
<b>Co-60</b>	0.45	1.00
<b>Tc-99m</b>	0.0018	0.99
<b>Am-241</b>	0.00072	0.98

	Breakthrough times [a]		
	t 5%	t 50%	t 95%
<b>I-131, Dirac</b>	0.50	0.50	1.0
<b>Sr-85, Dirac</b>	0.50	0.51	2.5
<b>Co-60, Dirac</b>	4.7	6.7	267
<b>Tc-99m, Dirac</b>	166	664	65 349
<b>Am-241, Dirac</b>	415	1654	162 880



## Appendix O

Modelling of STT1B for T6A&B  
H. Cheng (WRE-KTH/SKB)



# **Modeling of Sorbing Tracer Tests STT-1B For Task 6A and Task 6B**

Hua Cheng, Water Resources Eng., KTH  
Vladimir Cvetkovic, Water Resources Eng., KTH

September 11-13, 2001  
15<sup>th</sup> Task Force Meeting  
Goslar, Germany

**Water Resources Engineering**



## Outlines

- Conceptual model
- mathematical model
- $\beta$ - $\tau$  relationship
- parameters employed in modeling
- Modeling results



# Conceptual model

A planar single fracture with spatial  
variable aperture

**Water Resources Engineering**



## Key transport mechanism

- Advection
- Mass transfer (retention) processes
  - Sorption on fracture surface
  - Diffusion into rock matrix and sorption in the matrix



## Mathematical model

For a single fracture, pulse injection

$$g^{(M)}(t, \mathbf{t}; \mathbf{b}) = \frac{H(t - \mathbf{t})\mathbf{k}\mathbf{b}}{2\sqrt{\mathbf{p}}(t - \mathbf{t} - K_a \mathbf{b})^{3/2}} \exp\left[\frac{-\mathbf{k}^2 \mathbf{b}^2}{4(t - \mathbf{t} - K_a \mathbf{b})}\right]$$

$$\mathbf{k} = \mathbf{q}\sqrt{D(1 + rK_d^m / \mathbf{q})}$$

Following a trajectories

$$\mathbf{t}(L) = \int_0^L \frac{dx}{V_x(x)}$$

$$\mathbf{b}(L) = \int_0^L \frac{dx}{V_x(x)b(x)}$$



For a continuous injection

$$Q(x, t) = \int_0^\infty \int_0^\infty [\mathbf{f}(t) * \mathbf{g}(t, \mathbf{t}; \mathbf{b})] g(\mathbf{t}, \mathbf{b}; x) d\mathbf{t} d\mathbf{b}$$

If  $\beta = k\tau$  (linear relationship)

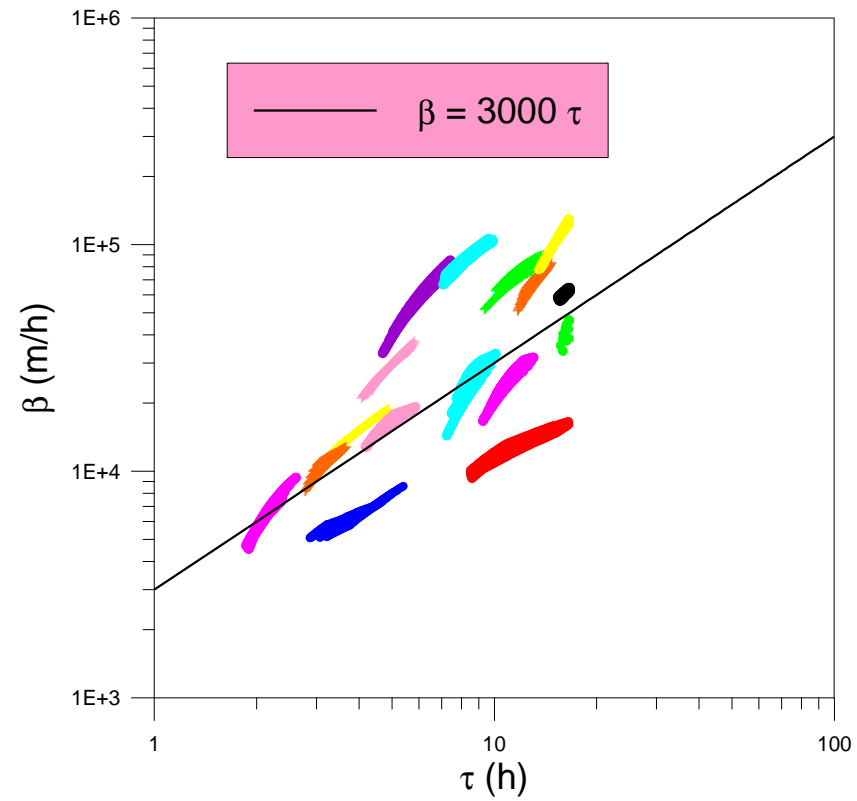
$$Q(x, t) = \int_0^\infty \int_0^\infty [\mathbf{f}(t) * \mathbf{g}(t, \mathbf{t}; \mathbf{b})] g(\mathbf{t}; x) d\mathbf{t}$$

(Integration over all trajectories)



# $\beta\tau$ relationship

$$\beta = 3000\tau$$







## Parameters employed in modeling

Task 6A (Based on TRUE-1 evaluation)

Porosity  $\theta = 0.02$

Archie's Law  $F = \theta^{.2}$

$$D = FD_w / \theta$$

$K_d^m$  (Batch data 1-2 mm)

$$\tau_m = 5 \text{ h}$$

$$Q_t^2 = 1.5 \text{ h}^2$$



## Task 6B

$$\tau_m = 5000 \text{ h}$$

$$\sigma_\tau^2 = 1.5 \times 10^6 \text{ h}^2$$

$$CV_A(\tau) = CV_B(\tau)$$

Two set of modeling

$$\theta = 0.01 \text{ \& } \theta = 0.02$$



## Modeling results

### Task 6A

### Dirac pulse input

Tracer	T <sub>5</sub> (h)	T <sub>50</sub> (h)	T <sub>95</sub> (h)	Max rate (1/y)
I-131	3.4	5.3	17.63	2396
Sr-85	3.6	6.2	55.7	1687
Co-58	102	220	5489	40.3
Tc	5727	34900	$1.9 \times 10^6$	2.3
Am	14330	87490	$4.7 \times 10^6$	9.4e-2



## Task 6A

### Experimental input

Tracer	T <sub>5</sub> (h)	T <sub>50</sub> (h)	T <sub>95</sub> (h)	Max rate (Bq/y)
I-131	5.2	16.8	133	5.8e+8
Sr-85	5.5	14.2	128	2.4e+8
Co-58	122	443	6329	7.5e+6
Tc	6015	35210	1.9×10 <sup>6</sup>	7.9e+5
Am	14640	87790	4.7×10 <sup>6</sup>	3.2e+5



## Task 6B

### Pulse injection

Tracer	Max rate (1/y)		$T_5$ (y)		$T_{50}$ (y)		$T_{95}$ (y)	
	$\theta = 0.01$	$\theta = 0.02$	$\theta = 0.01$	$\theta = 0.02$	$\theta = 0.01$	$\theta = 0.02$	$\theta = 0.01$	$\theta = 0.02$
I-131	0.14	3.3e-2	1.1	3.2	6.7	26.4	376	947
Sr-85	2.4e-2	9.6e-3	4.4	10.4	38.8	98.2	2283	5708
Co-58	2.0e-4	9.0e-5	479	1073	4566	10388	-	-
Tc	6.2e-7	2.6e-7	1.5e+5	3.8e+5	1.5e+6	-	-	-
Am	2.6e-7	-	3.8e+5	9.4e+5	-	-	-	-



## Task 6B

### Constant injection

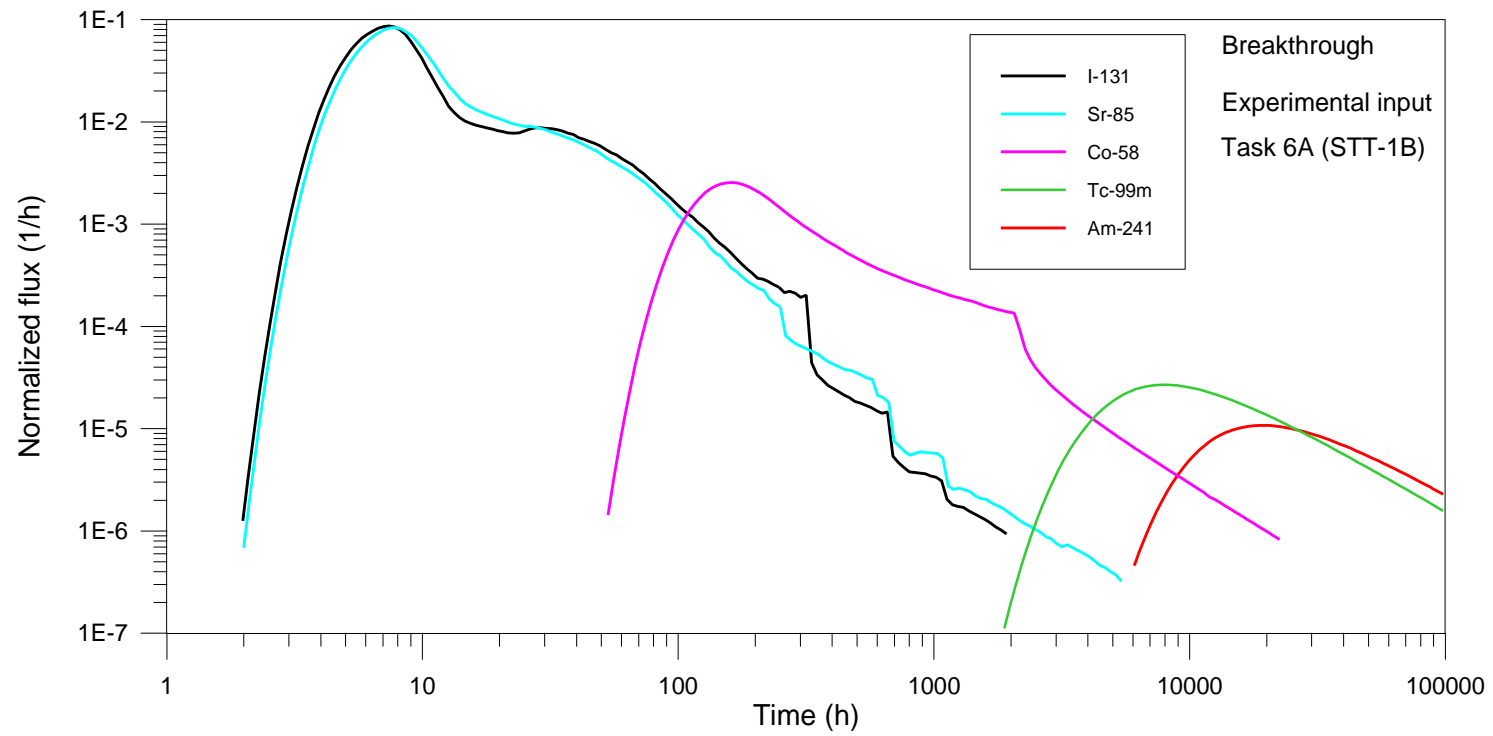
Tracer	Max rate (Bq/y)	
	$\theta = 0.01$	$\theta = 0.02$
I-131	1e+6	1e+6
Sr-85	1e+6	-
Co-58	-	-
Tc	-	-
Am	-	-



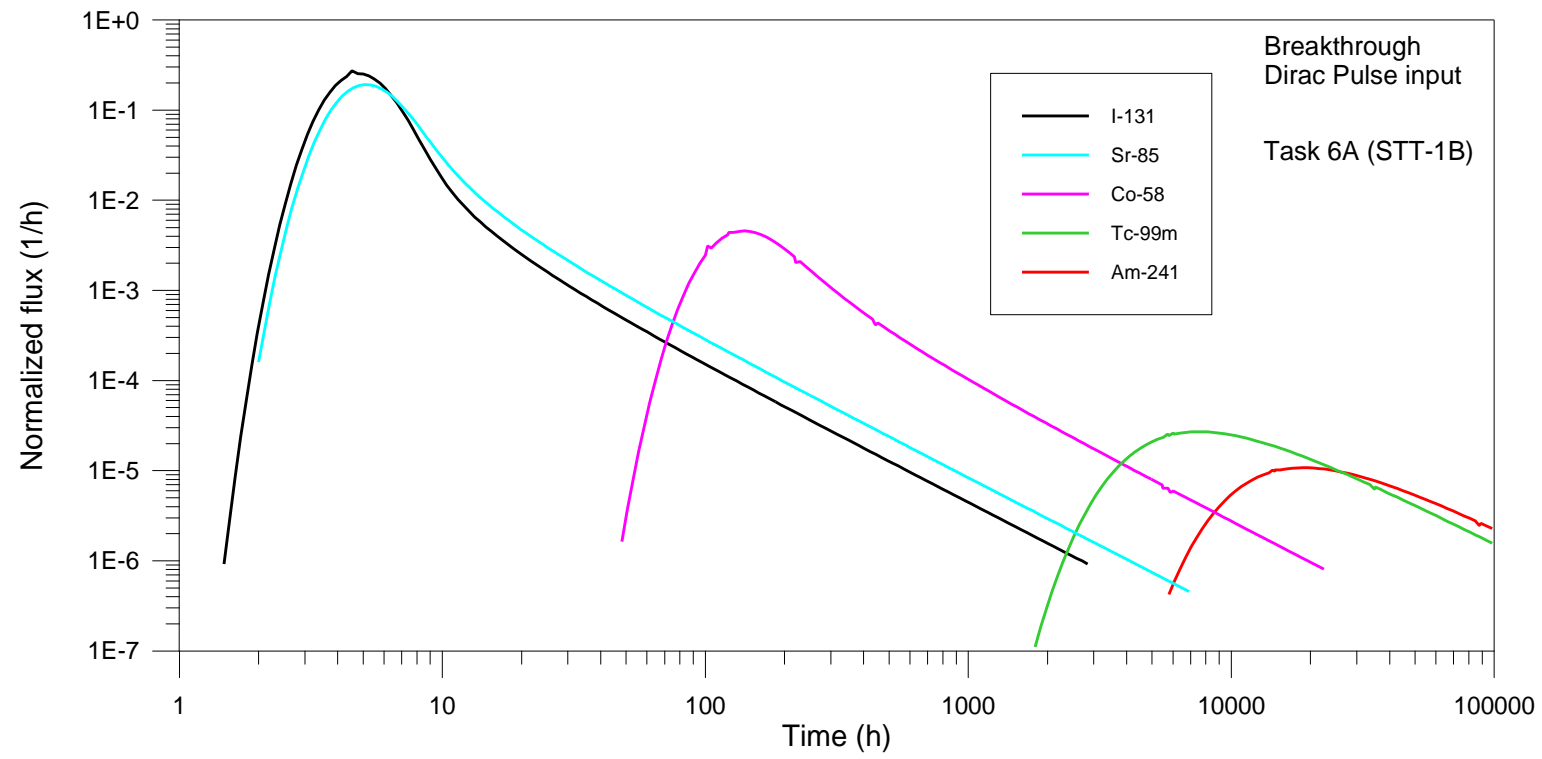
## References

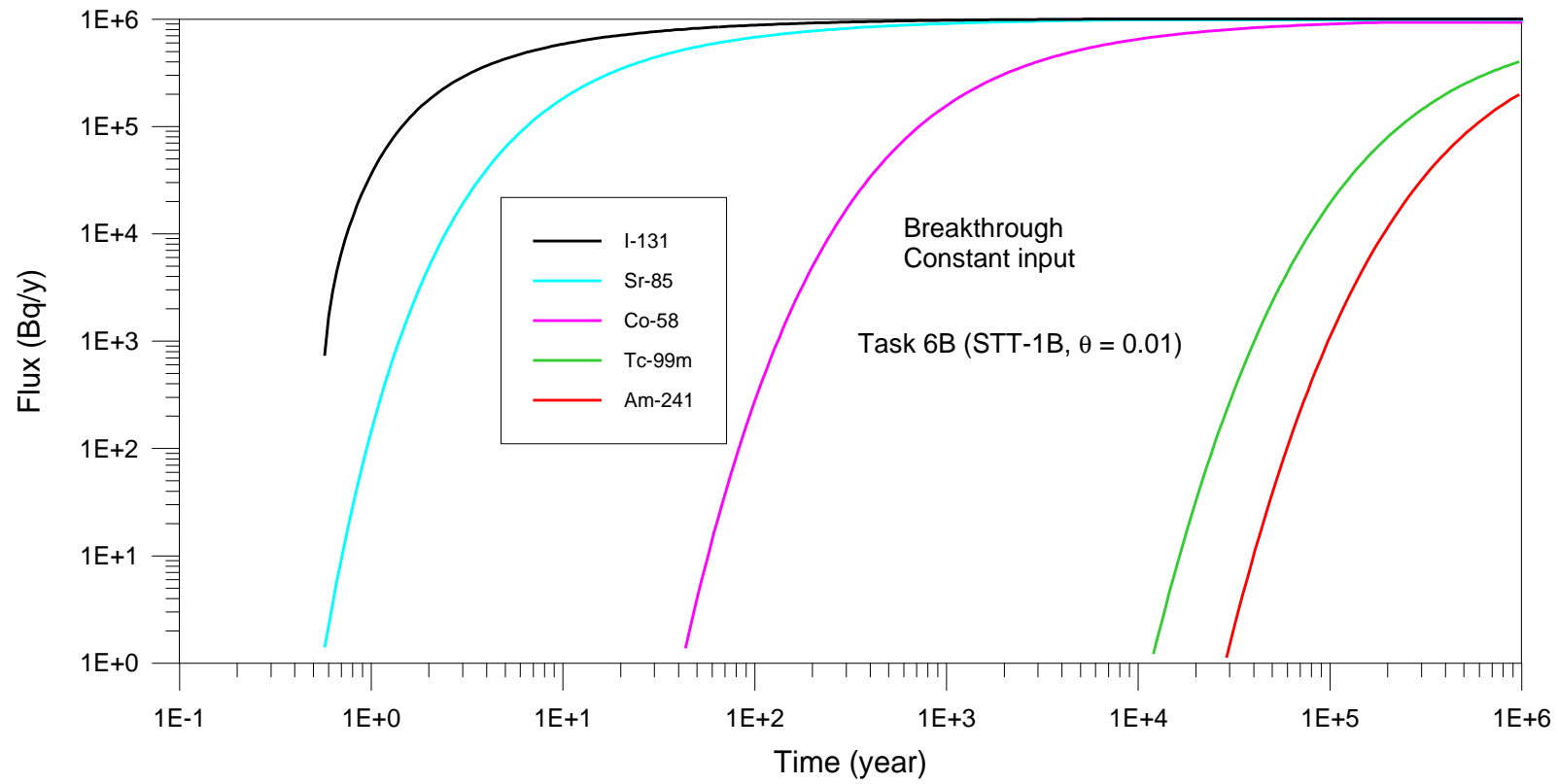
Cvetkovic, V., Selroos, J.-O., and Cheng, H.,  
Transport of reactive tracers in rock fractures, J.  
Fluid Mech., 378, 335-356, 1999.

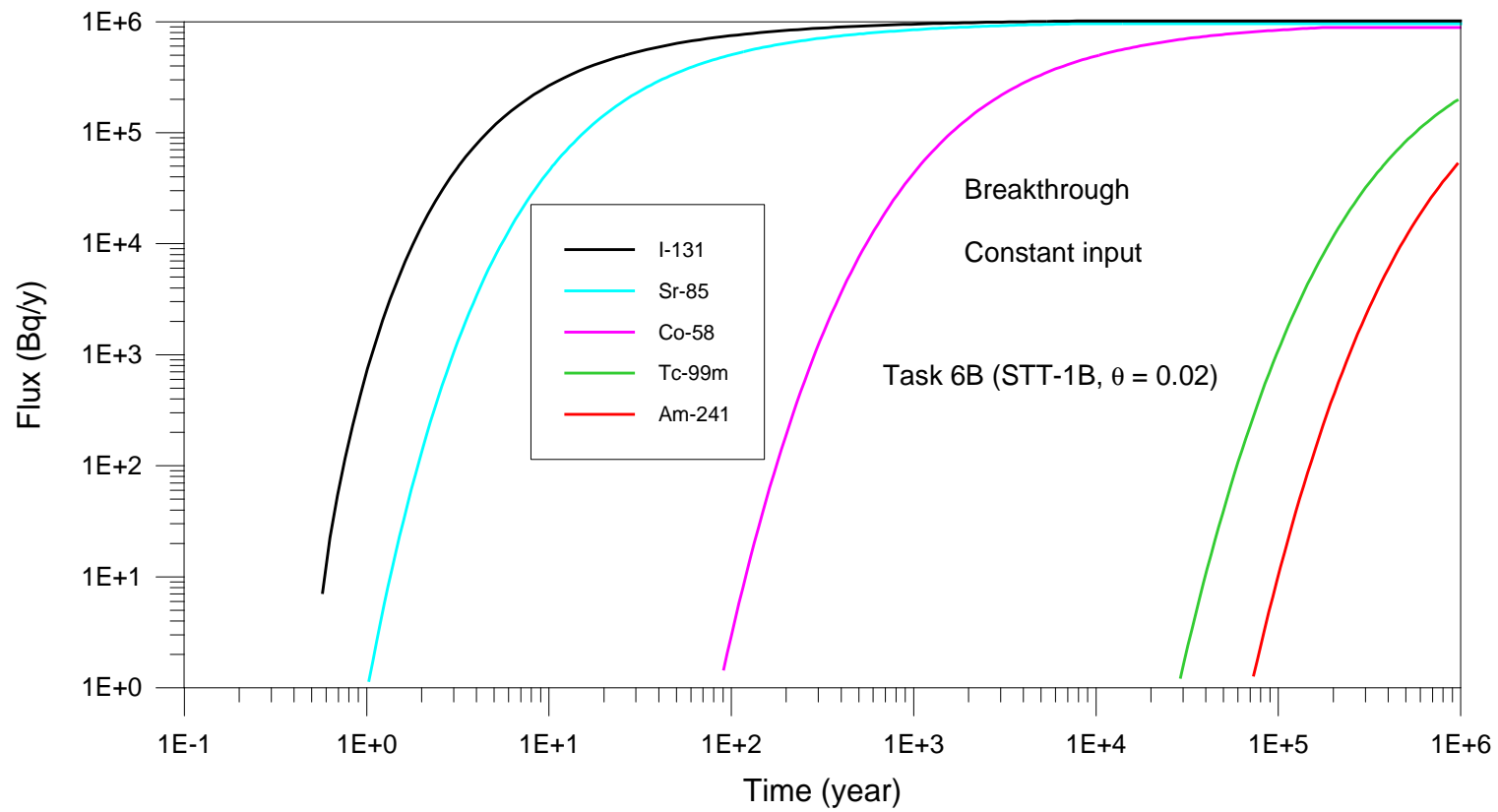
Cvetkovic, V., Cheng, H., and Selroos, J.-O.,  
Evaluation of Tracer Retention Understanding  
Experiments (first stage) at Äspö, International  
Cooperation Report, ICR-00-01, SKB.

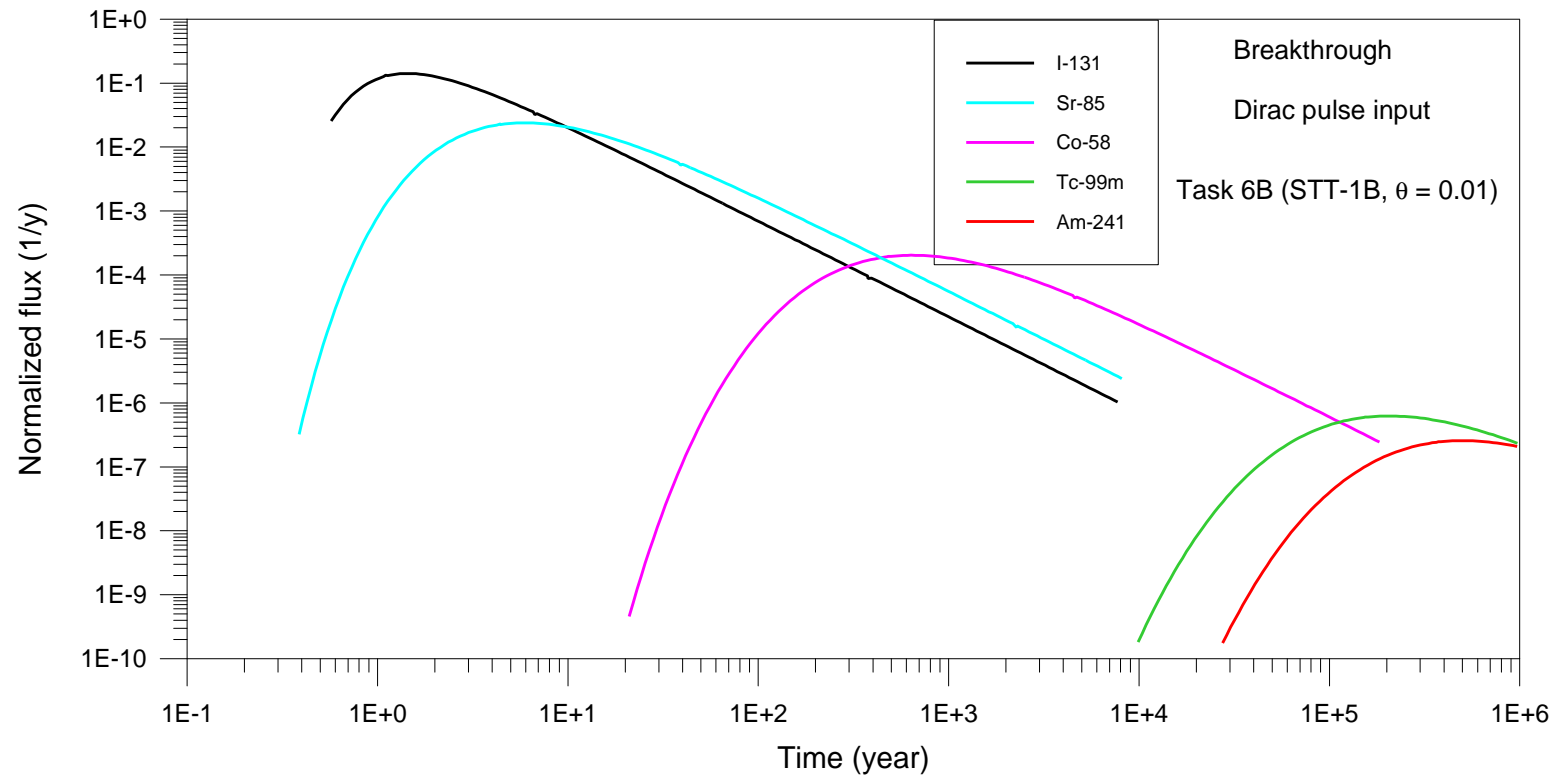


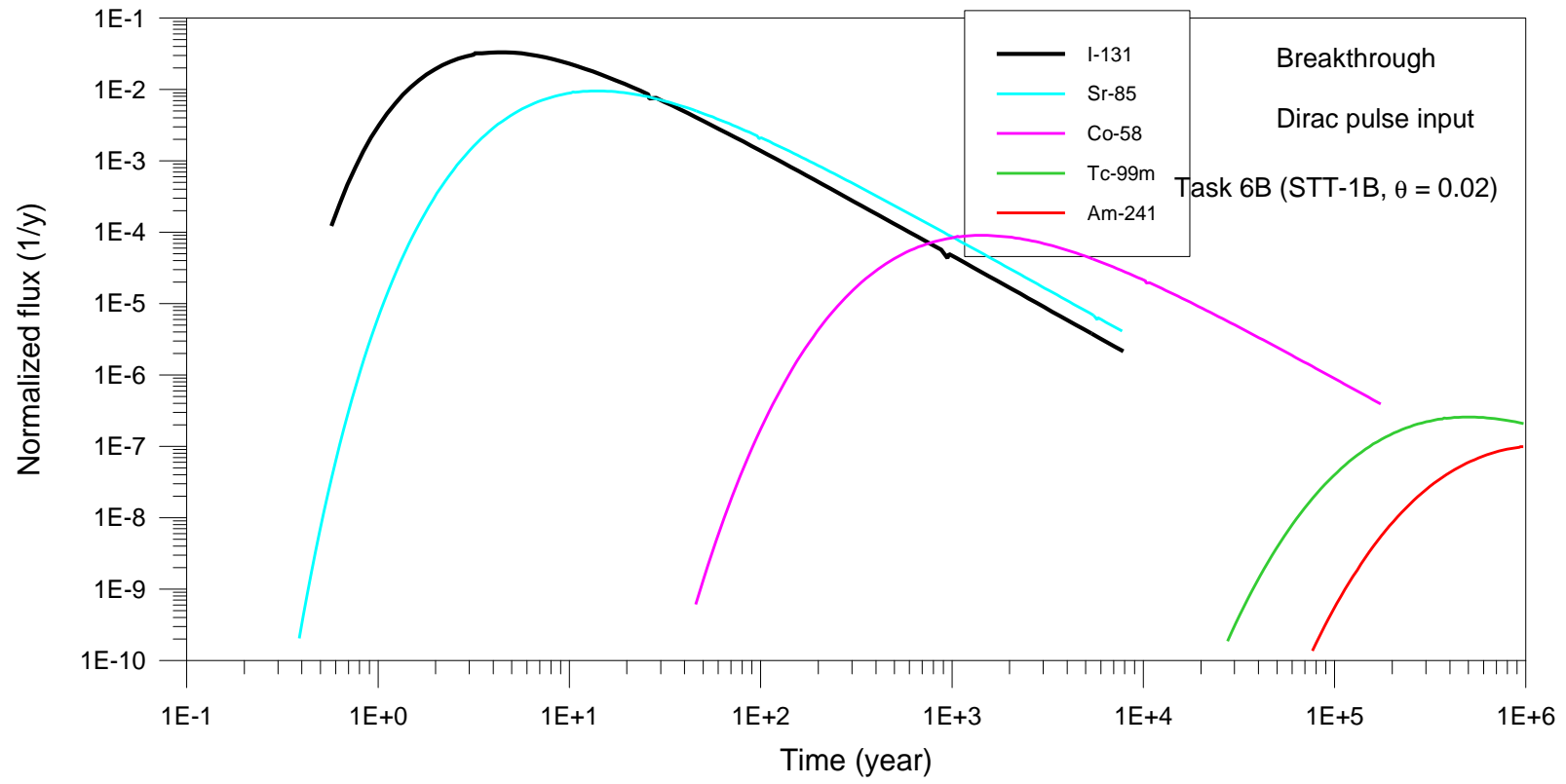












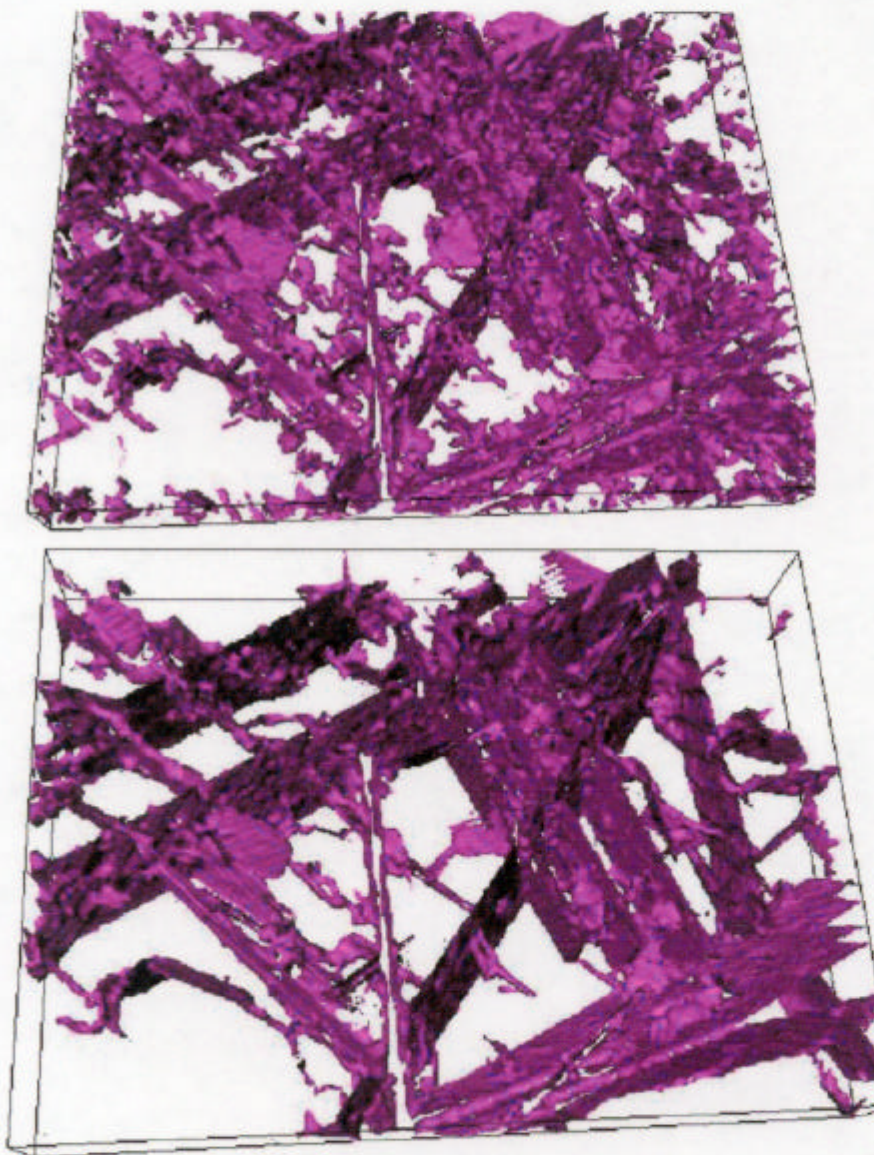
## Appendix P

FRAME: A subgrid model based on FRActal scaling laws and multi rate equations.  
U. Svensson (CFE/SKB)

## Application to Äspö HRL

- The method has been used in models of the Äspö Hard Rock Laboratory, which is a Swedish research facility run by SKB.
- Major fracture zones are treated deterministically, background fracture network is generated stochastically.
- $10^6$  fractures can be represented in a grid of  $2 \times 10^6$  cells.

### Example



*Illustration of porosity (top) and flow fields. Depth interval shown is 400 to 500 metres below ground level. The flow is from west to east. View from south.*

## Flow and Transport in a fracture network

The **SOS**-concept (**S**eparation **O**f **S**cales):

### Flow

“Relatively few flow channels give 99% of the flow.

⇒ Can be described in a numerical model (grid)”

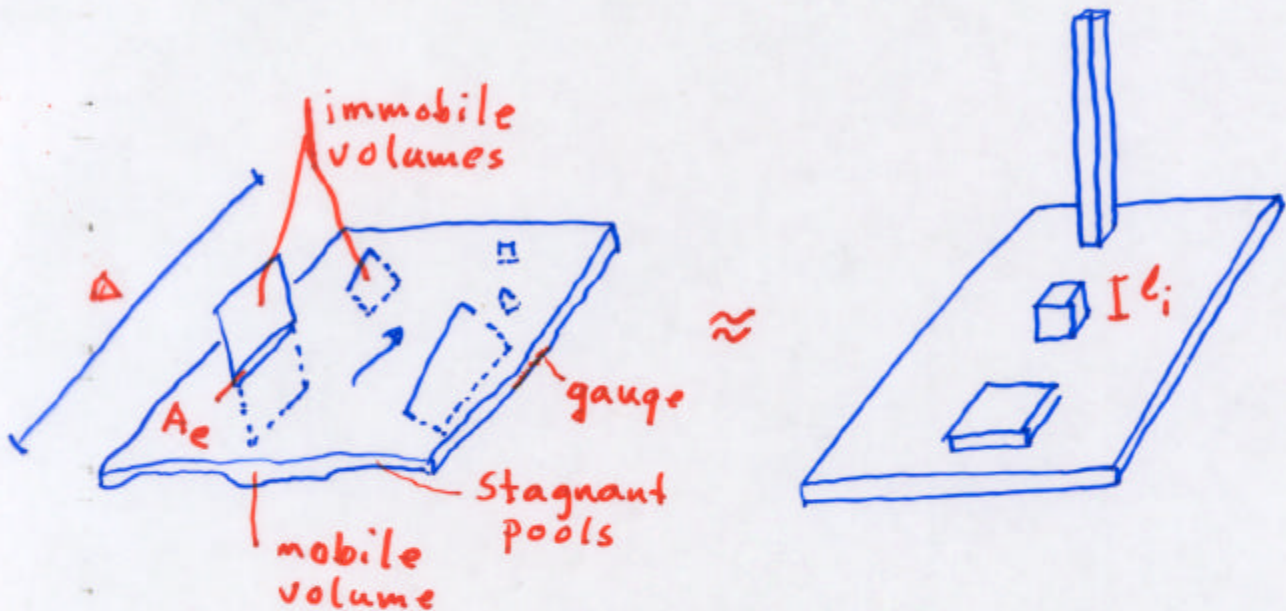
### Transport

“Fractures, stagnant pools, etc from the length scale of mm to m most important for dispersion of a tracer pulse

⇒ We need a subgrid model to describe these processes”



**FRAME**; a subgrid model based on **FRA**ctal scaling laws and **M**ultirate **E**quations.



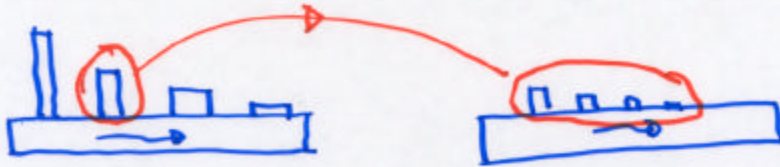
**Main steps**

- Divide the immobile volumes into a number of size groups.
- Generate the number of fractures in each size group from a power-law with exponent  $\alpha_p$  (fractal scaling law).
- Only fractures within a distance  $l_{size\ group}$  can be in contact with the mobile volume.
- Assume that the “exposed area”,  $A_e$ , is related to the length scale of the immobile volume, i.e.  $A_e \sim l^2$

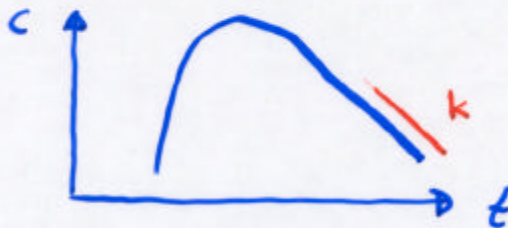
Note: for  $l \gg l_{min}$  we assume that volumes are due to fractures and  $A_e$  is hence proportional to the aperture. For  $l \approx l_{min}$  the volumes may however be made up of stagnant pools, water in between grains, etc.

## Some technical points

- Each immobile volume is represented by a series of “first order capacity boxes”



- When all immobile volumes have been represented we get a continuous distribution of capacities.
- Prove that this distribution is a power-law distribution (analytically and numerically).
- Base FRAME on this distribution .
- $\alpha_p + \gamma$  can be related (analytically) to the “late time slope” of the breakthrough curve,  $k$ .



- Use  $k, \beta_{tot}, R_m, D_a$  as main model parameters. We also need to specify the size limits of the immobile zones.  
Note: All model parameters have a clear physical meaning.

## Results

### Breakthrough curves

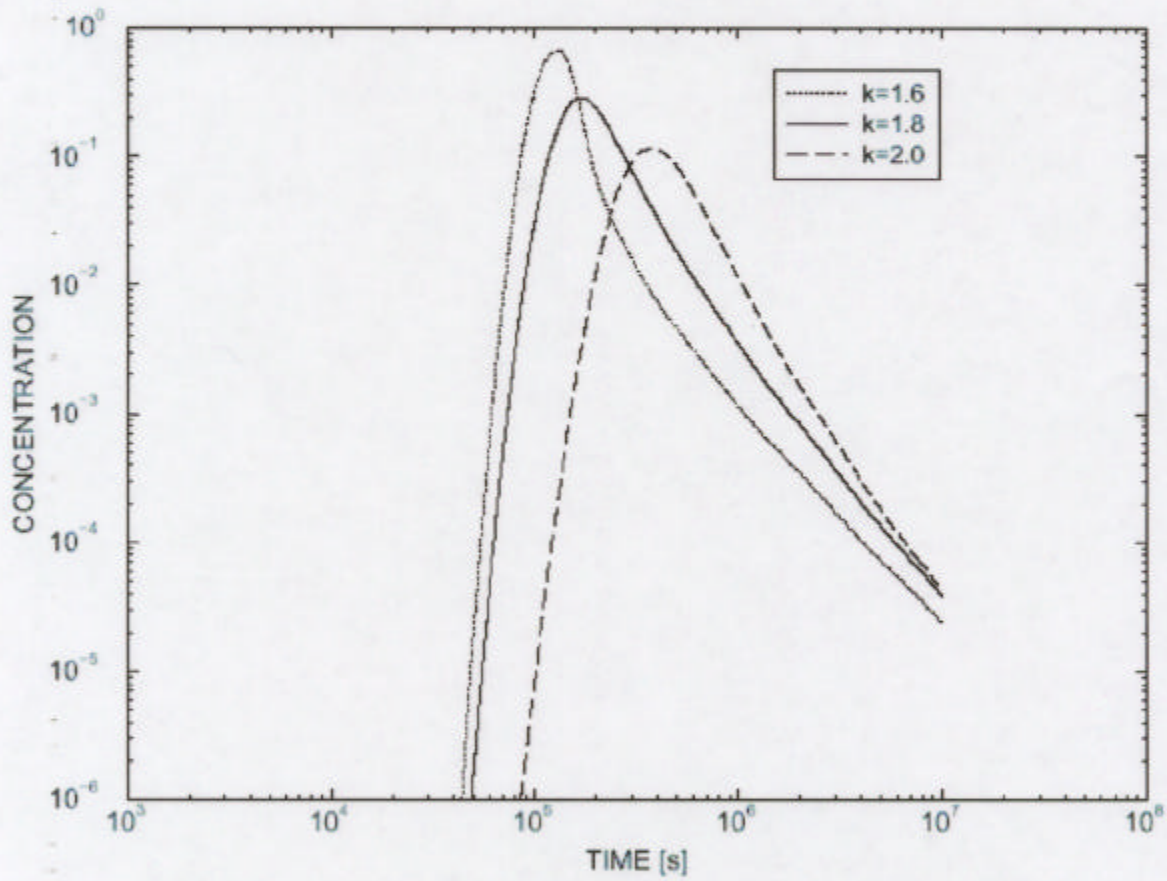
$$\beta_t = 10$$

$$D_a = 10^{-10} \text{ m}^2/\text{s}$$

$$k = 1.6, 1.8, 2.0$$

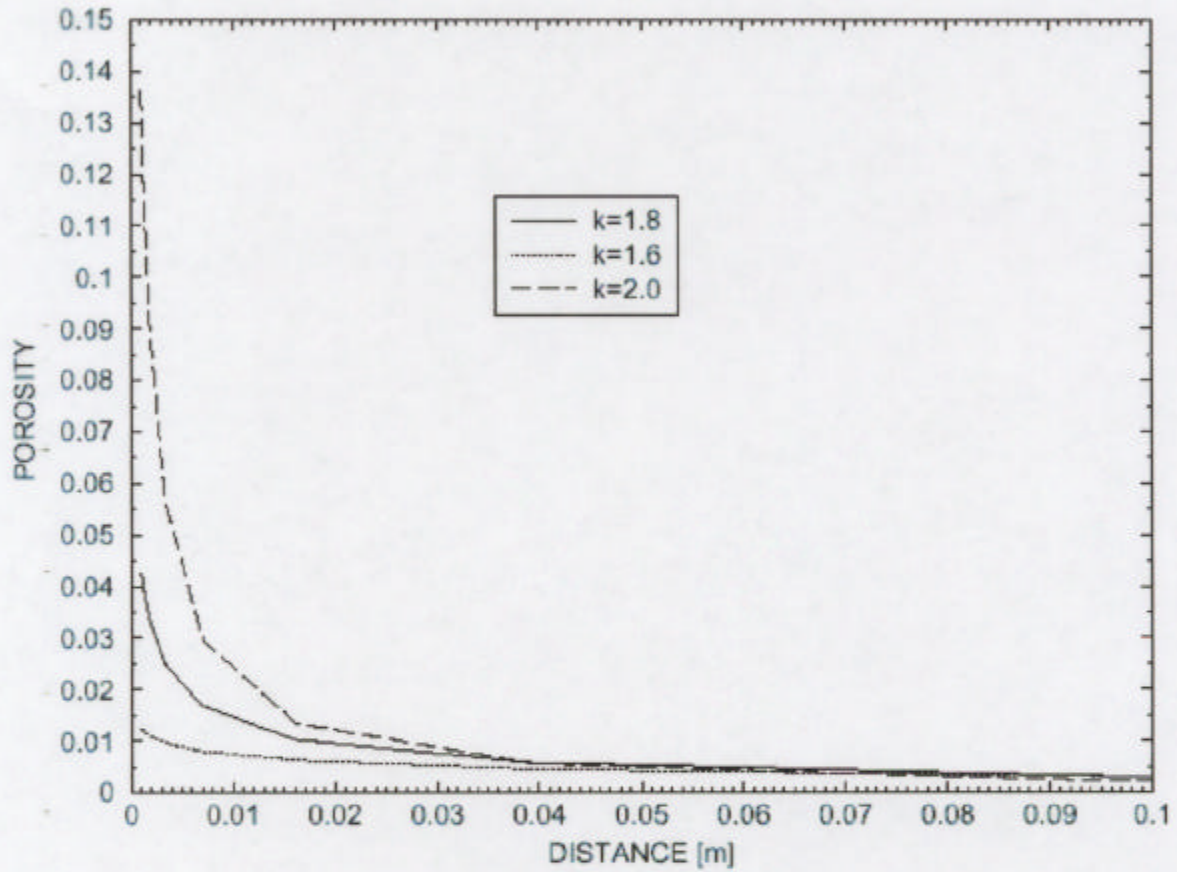
$$l_{min} = 1 \text{ mm}$$

$$l_{max} = 1 \text{ m}$$



## Results

### Porosity distribution close to mobile zone



## Concluding remarks

- **FRAME is developed for both advection/diffusion equations and particle tracking (PARTRACK).**
- **Can be used in large-scale 3D simulations with several million cells.**
- **FRAME is developed for both short (months) and long-time ( $10^x$  years) transport problems. For *PA* time scales (Task #6) large storage volumes will come into play. Note: If the diffusion length scale is larger than  $\Delta$ , the fracture network represented in the grid “takes over”.**
- **Fractures from the mm to km scale can hence be represented, one way or the other, in a large 3D model.**
- **The SOS and FRAME concepts do not require any upscaling.**
- **Thus, FRAME seems to be a suitable tool for Task #6.**

## Appendix Q

Simulation results for T6A&B  
S. Follin (SF GeoLogic/SKB)

# Simulation Results for T6A & T6B

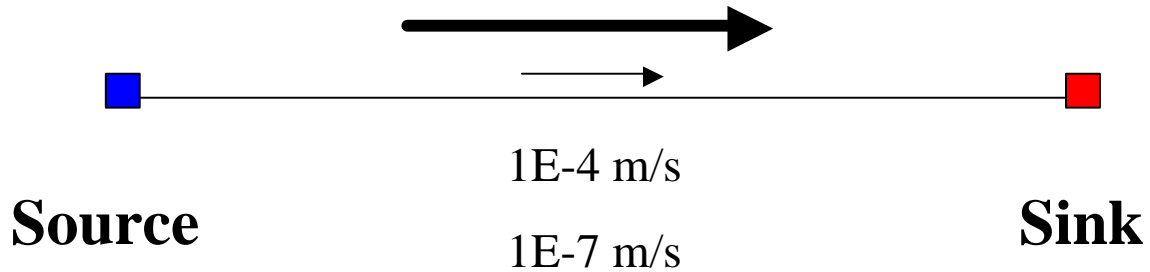
*CFE & SF GeoLogic*

(SKB)

**TF #15, 10 - 13 September 2001**

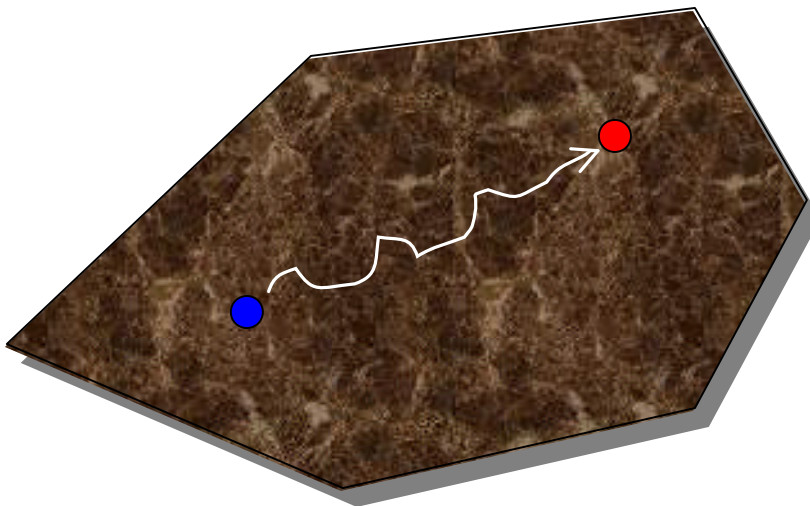
# Task 6A & 6B (B' B'')

1D



→ **Objective:** To improve our understanding of the Power Law M-R Diffusion Model

2D



$\mathbf{v}_{SC}$

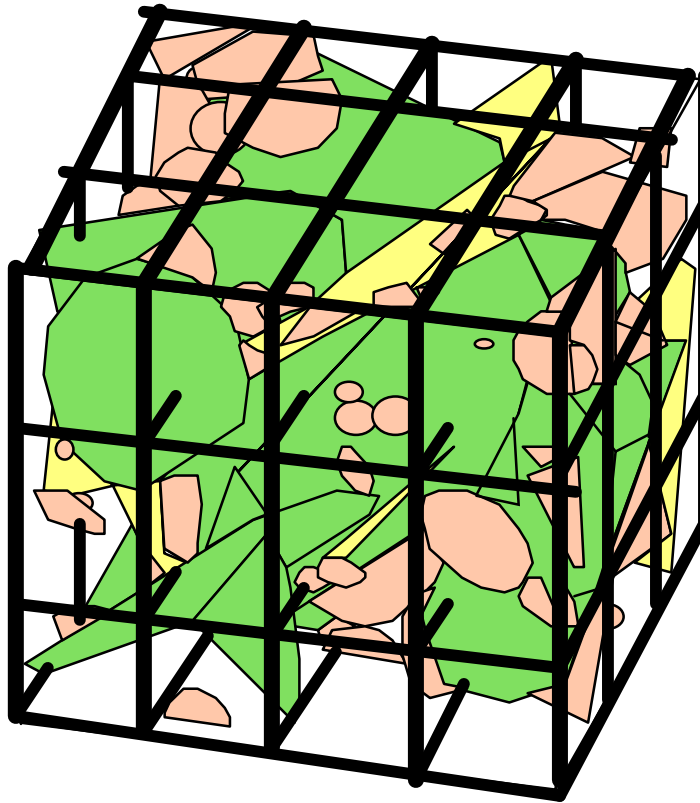
$\mathbf{v}_{PA}$

→ **Objective:** To study the implications of spatial variability.



# Task 6D & 6E

3D

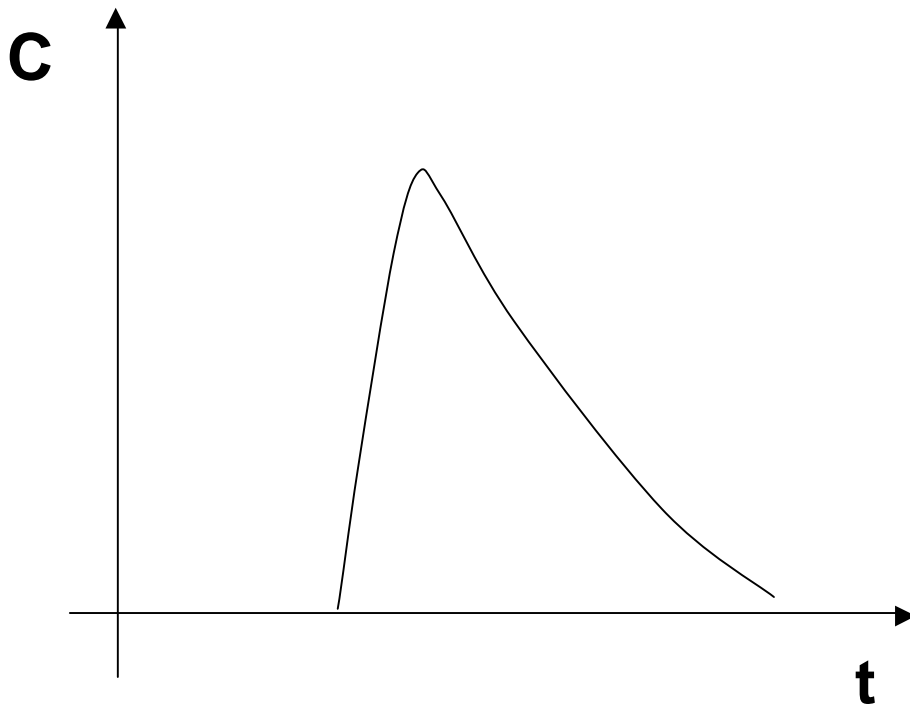


→ **Objective:** To study SC & PA transport in a 3D Fracture Network based on TRUE Block Scale data by means of exploration simulations.

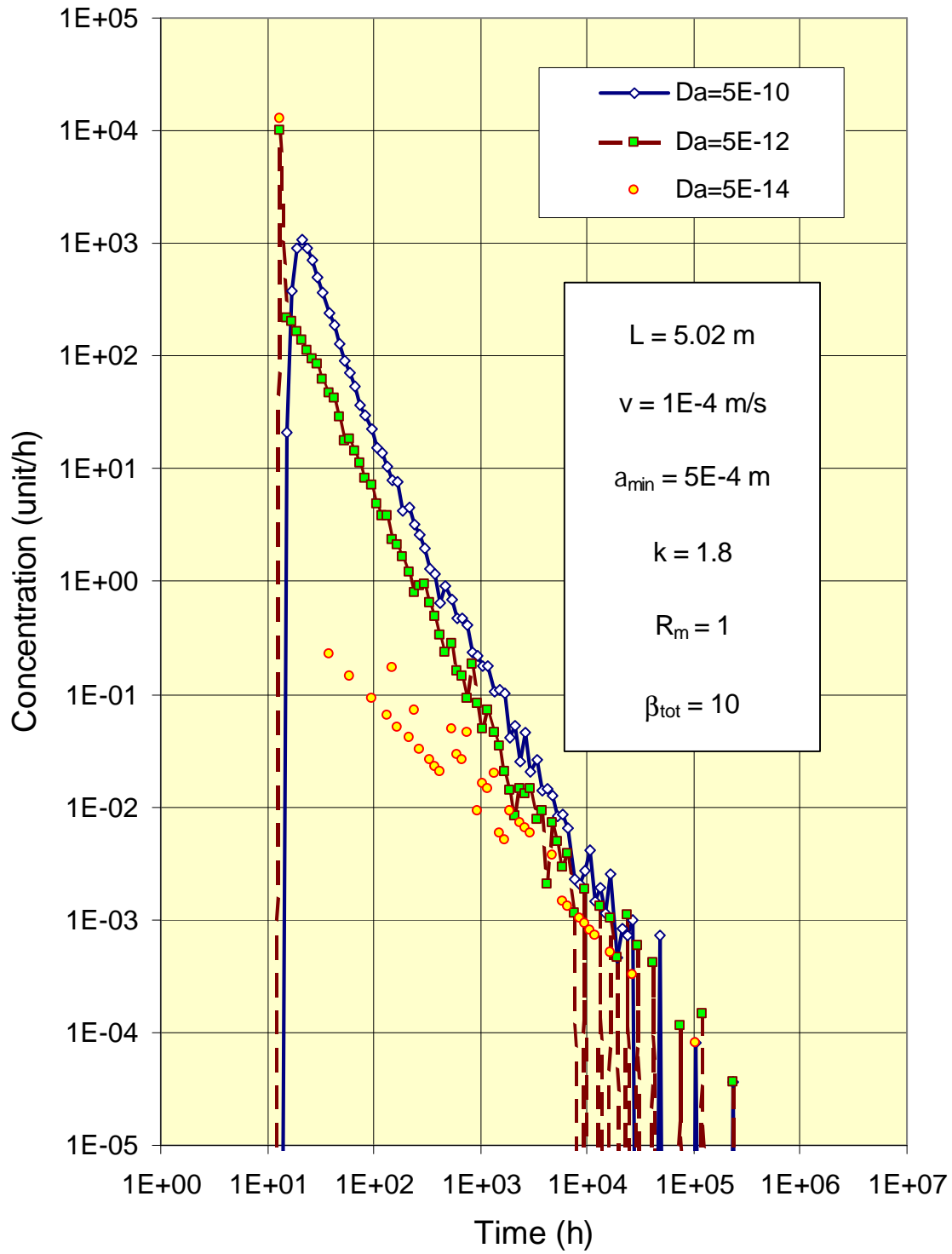
Cell width ( $\Delta$ )  $\sim 1\text{m} \Rightarrow 1\text{M}$  nodes for a  $(100\text{ m})^3$  cube.

Sensitivity studies focusing on:

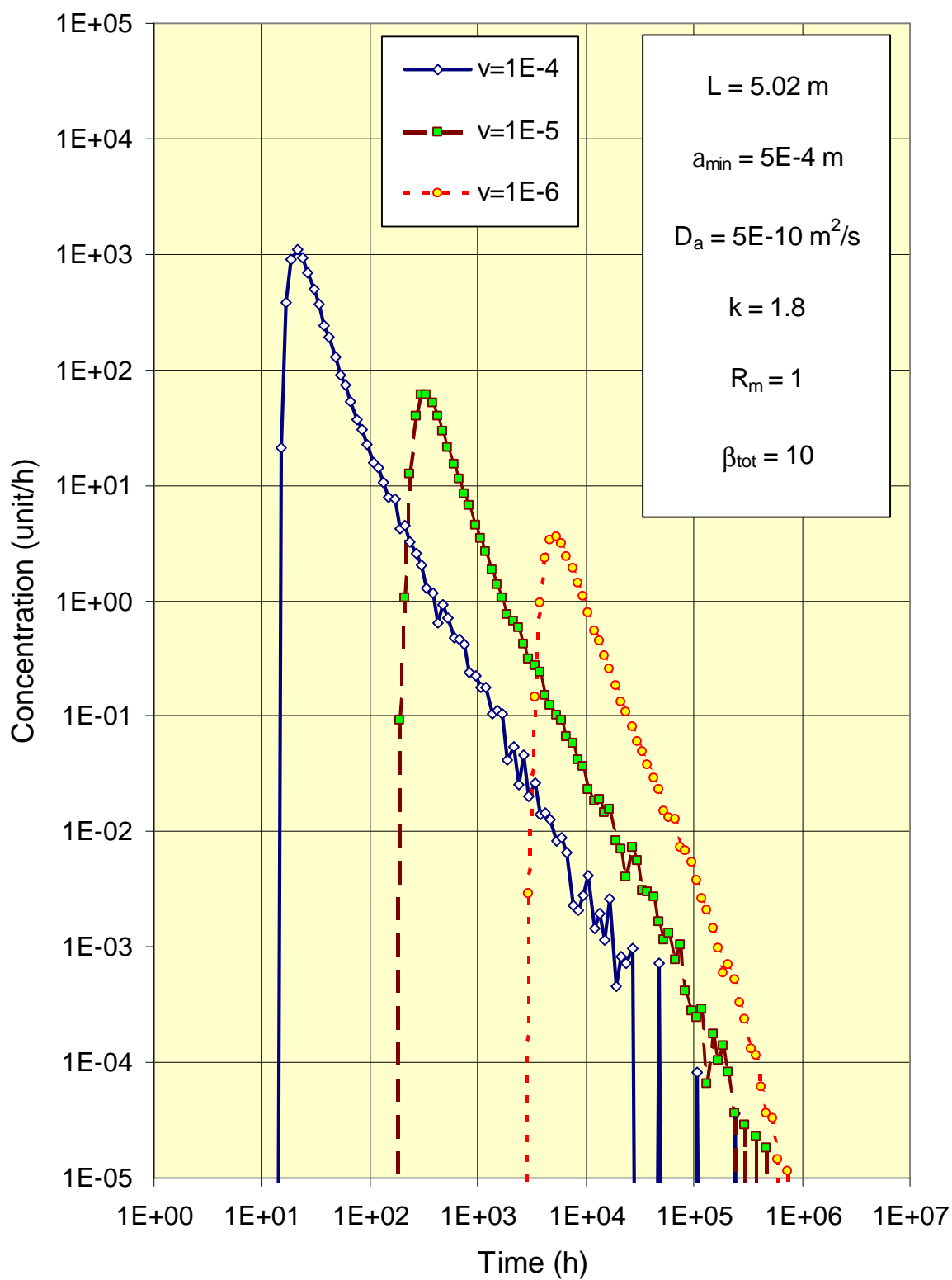
**k** **D<sub>a</sub>** **R<sub>m</sub>** **b<sub>tot</sub>**



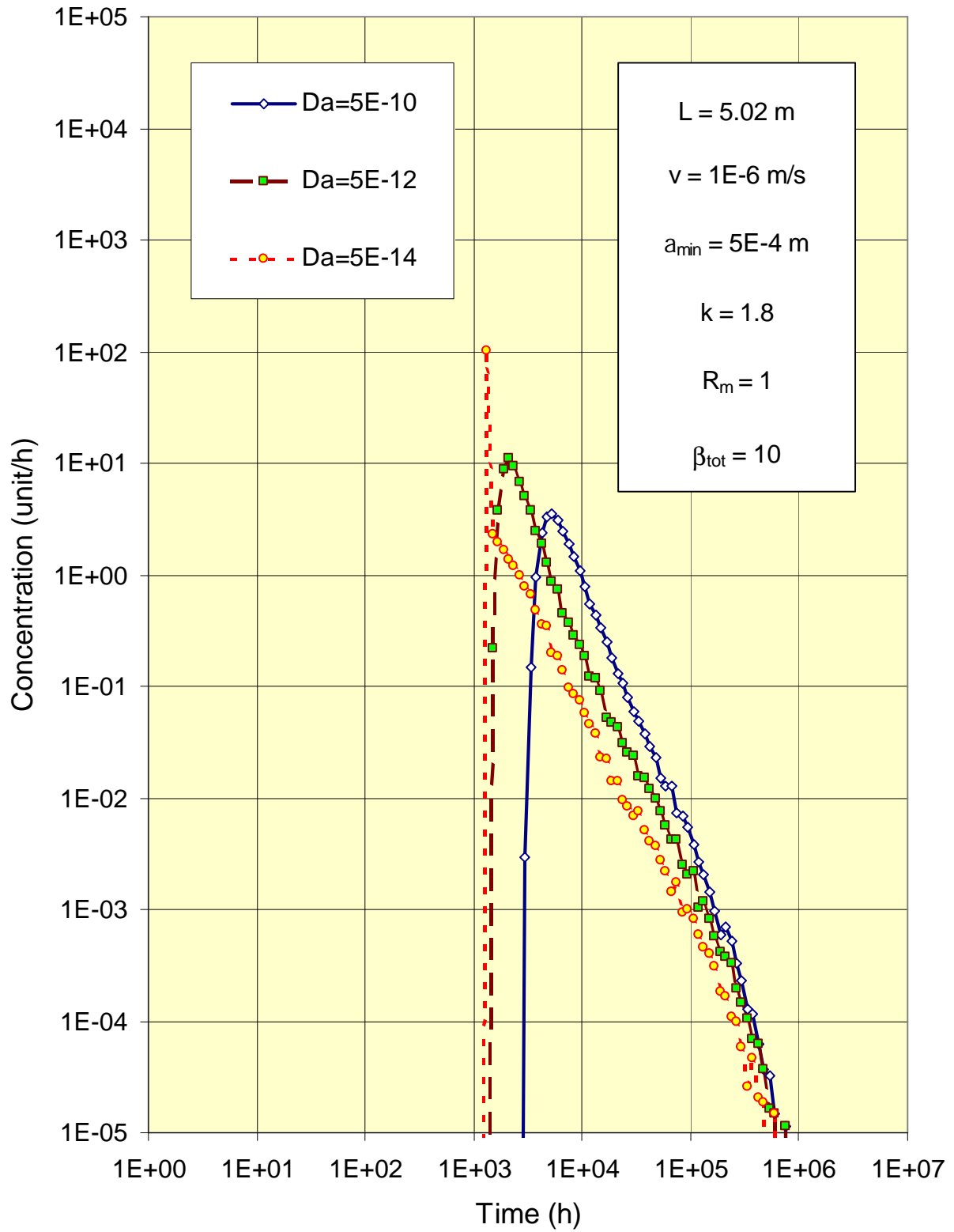
# 1. Sensitivity to $Da$ (SC)



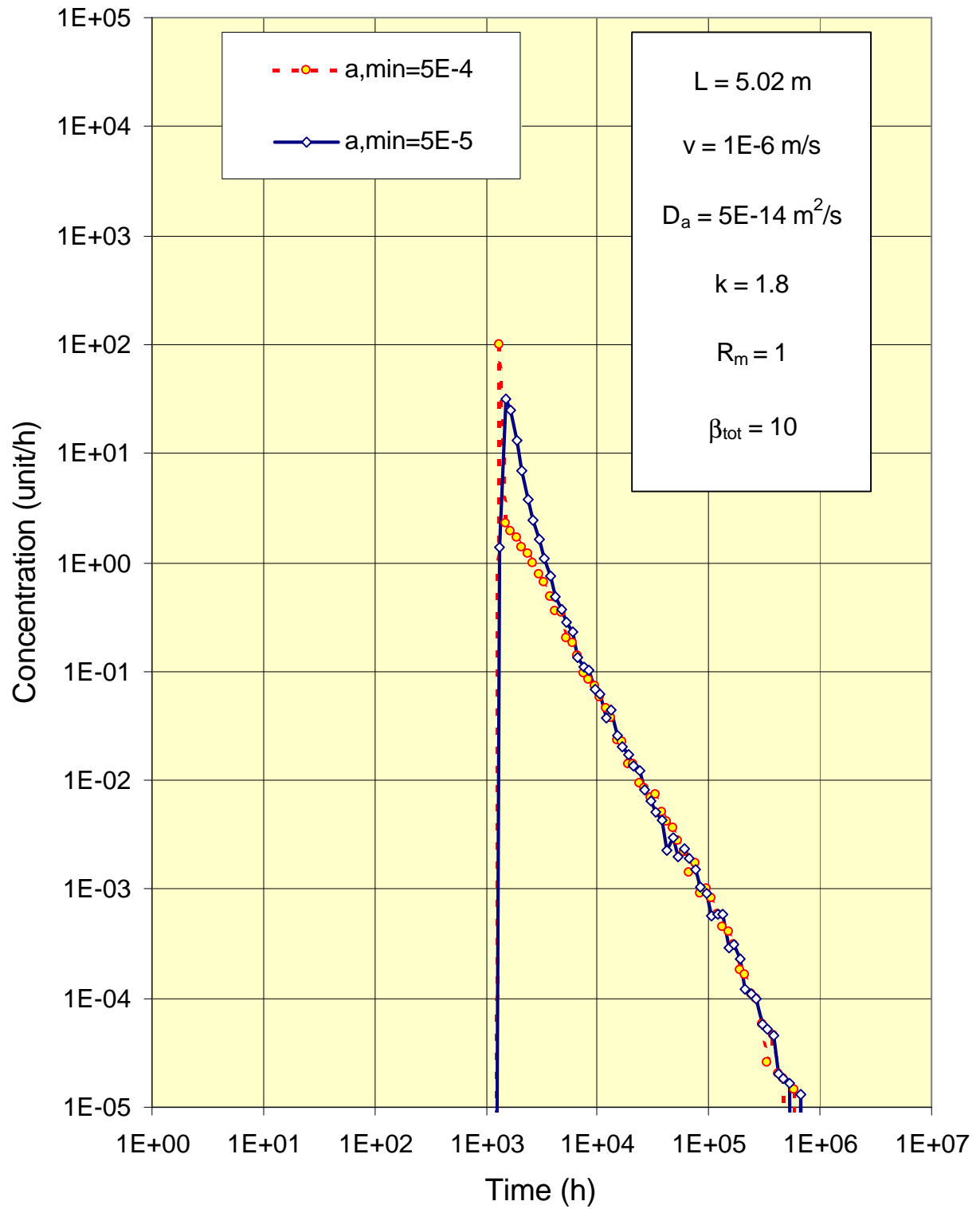
## 2. Sensitivity to $v$ (SC $\rightarrow$ PA)



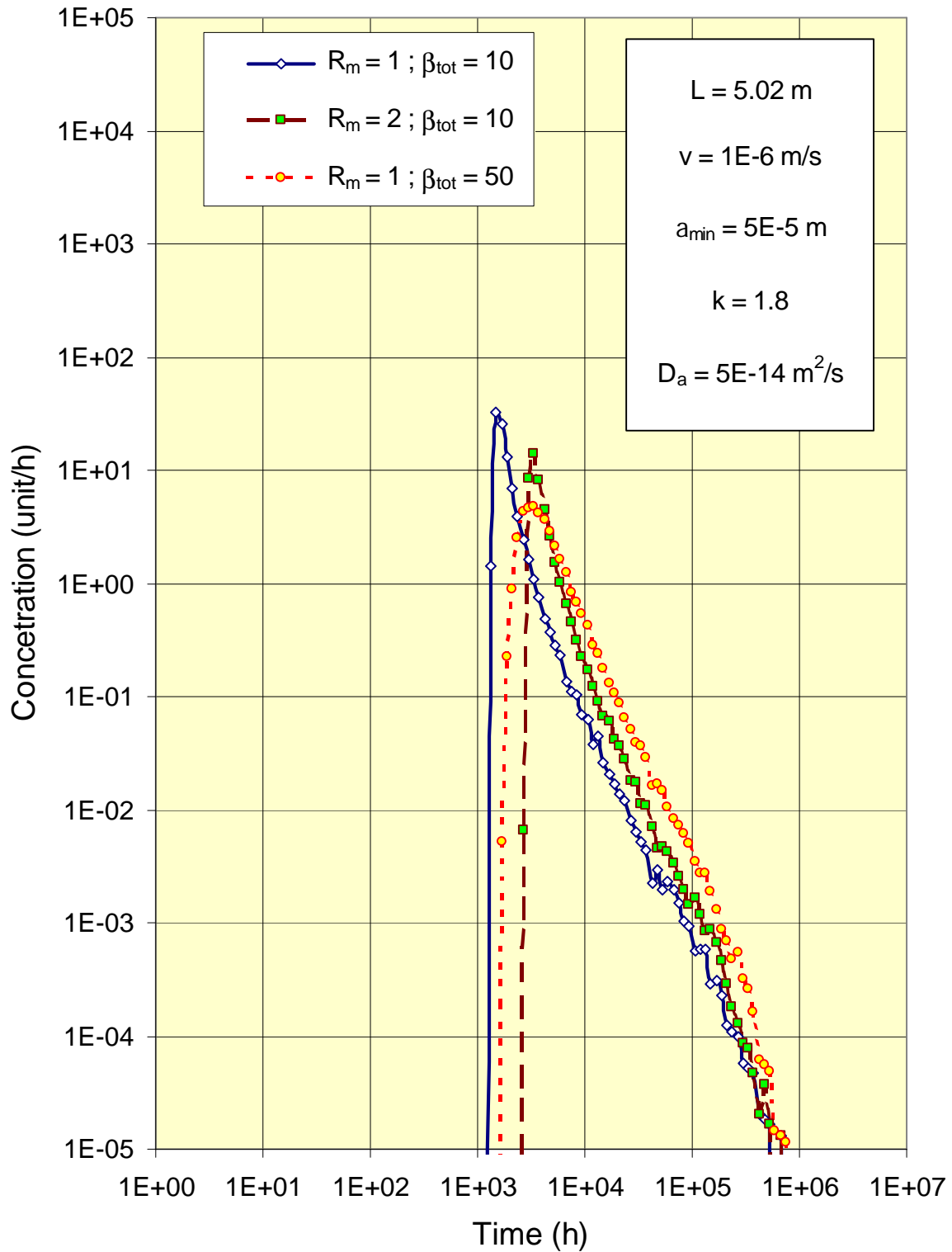
### 3. Sensitivity to $D_a$ (PA)

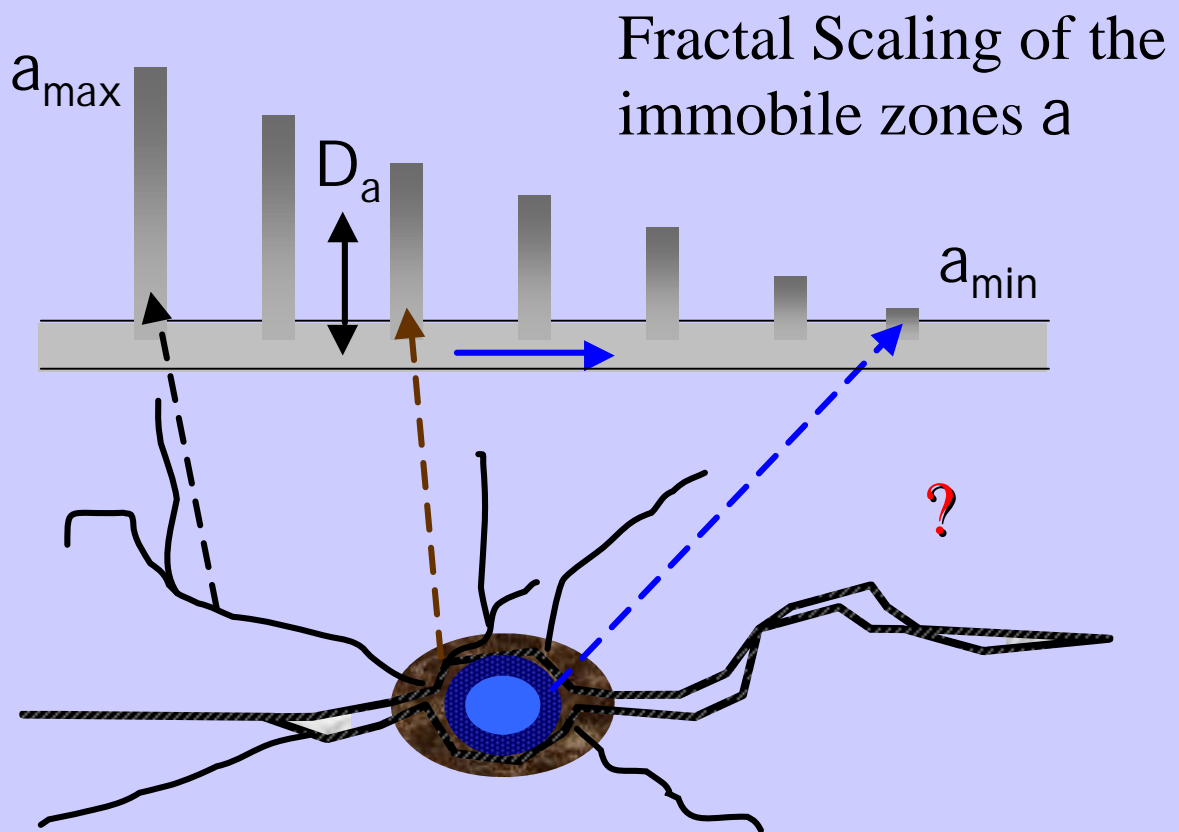


## 4. Sensitivity to $a_{\min}$ (PA)



## 5. Sensitivity to $R_m$ and $\beta_{tot}$ (PA)





If  $v$  is large (SC) the exposure to the different immobile zones is short, hence diffusion is restricted to the stagnant water adjacent to the flowpath, i.e.  $a_{\min}$  and  $D_a \rightarrow D_w$ .

A more distant diffusion, i.e. diffusion into  $a > a_{\min}$  where  $D_a \rightarrow D_e$ , probably requires a much longer exposure time (PA).

**Question:** Do we need a M-R diffusion model with variable  $D_a$  ?

$$a_{\min} \rightarrow D_w$$

$$a_{\max} \rightarrow D_e$$



## Appendix R

[Task 6A and 6B Modelling with 3FLO.  
Billaux \(ITASCA/ANDRA\)](#)

# **Task 6A & 6B modelling with 3FLO**

*Preliminary results*

**ITASCA / ANDRA team**

**Daniel BILLAUX - Benoît PARIS**



**ITASCA  
Consultants s.a.**

*Ref. 00801r*

*1*

**Äspö Task 6 Meeting  
Goslar – 09/11/2001**

# Outline

- Presentation of the work context
- Capabilities of *3FLO*, the ITASCA code used for numerical simulations
- Modelling Task A
- First try at Task B !

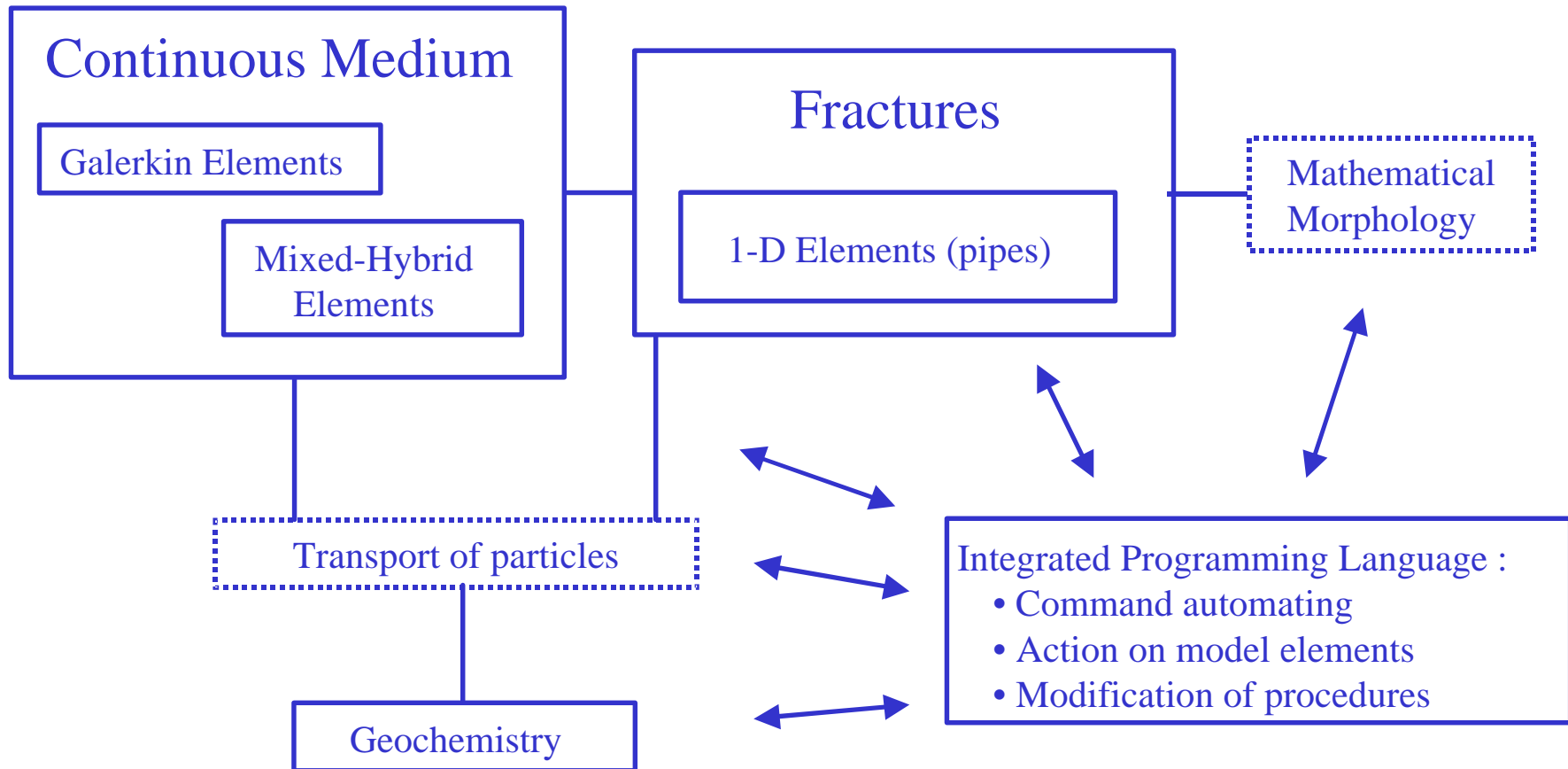
# Objectives

- Get started on feature A
- Try the Kd approach for later comparisons

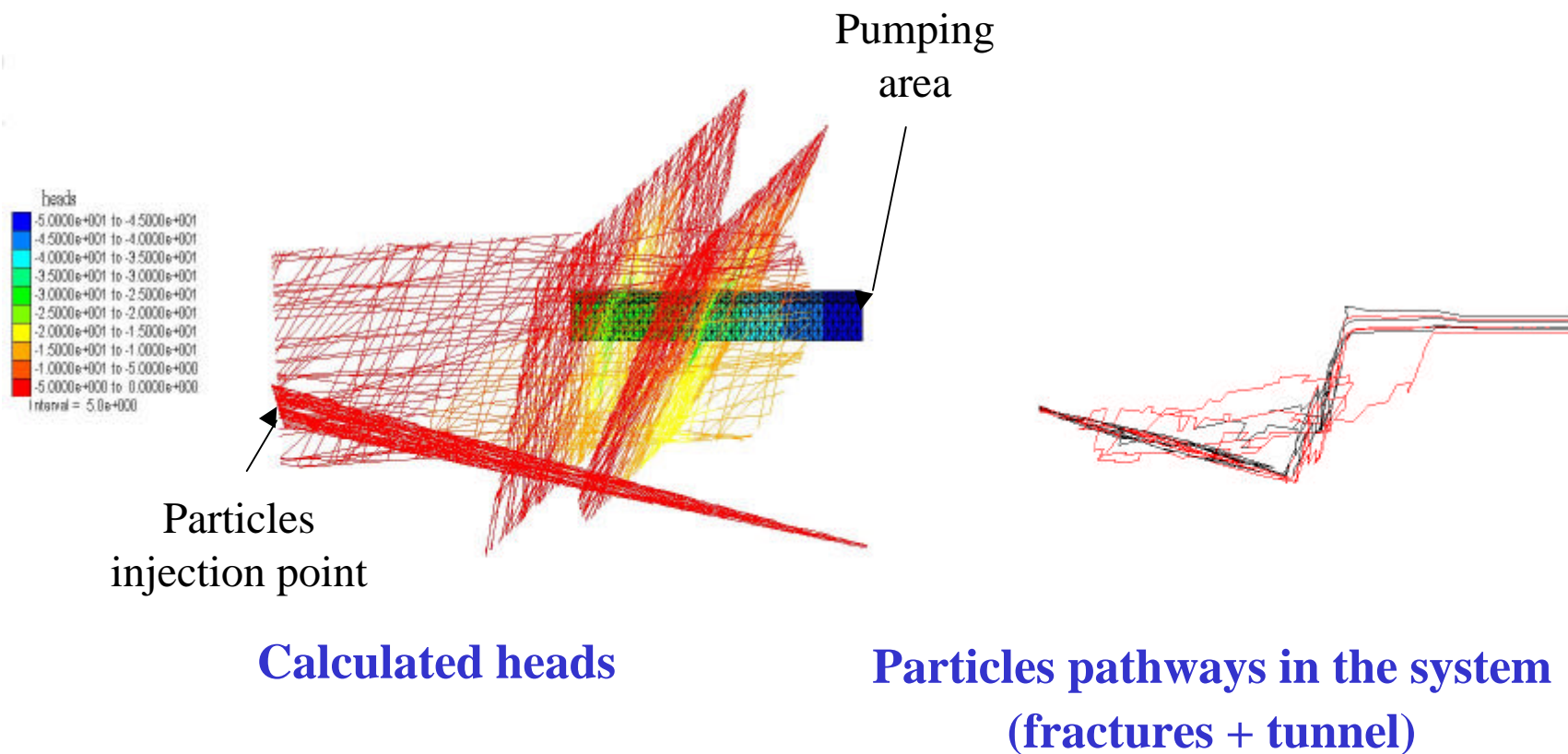
# *3FLO* main capabilities

- 3 Dimensional groundwater flow and mass transport in fractured and/or porous media
- Finite elements method (Galerkin or mixed-hybrids) : 1D, tetrahedron, hexahedron
- Transport is simulated with the Discrete Parcel Random Walk Approach
- Retardation factors can be simulated either with a user-provided isotherm or by coupling with the *3FLO* speciation module

# Description of 3FLO



# Example : transport within a fractured medium drained by a tunnel



# TASK A – 1<sup>st</sup> part

Modelling STT-1b tracer tests for:

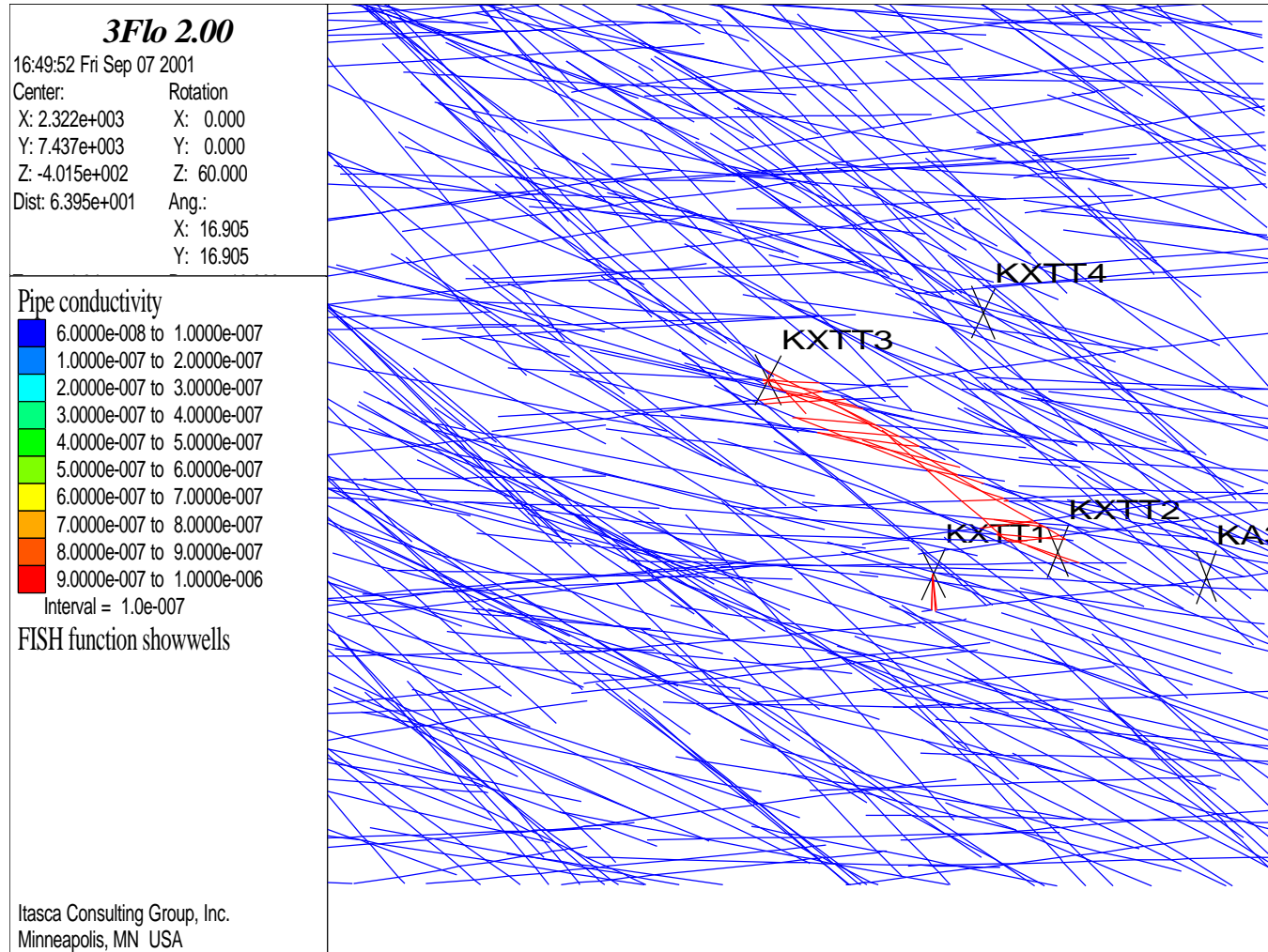
HTO, <sup>131</sup>I, <sup>85</sup>Sr and <sup>58</sup>Co



# Building a discrete fractures model

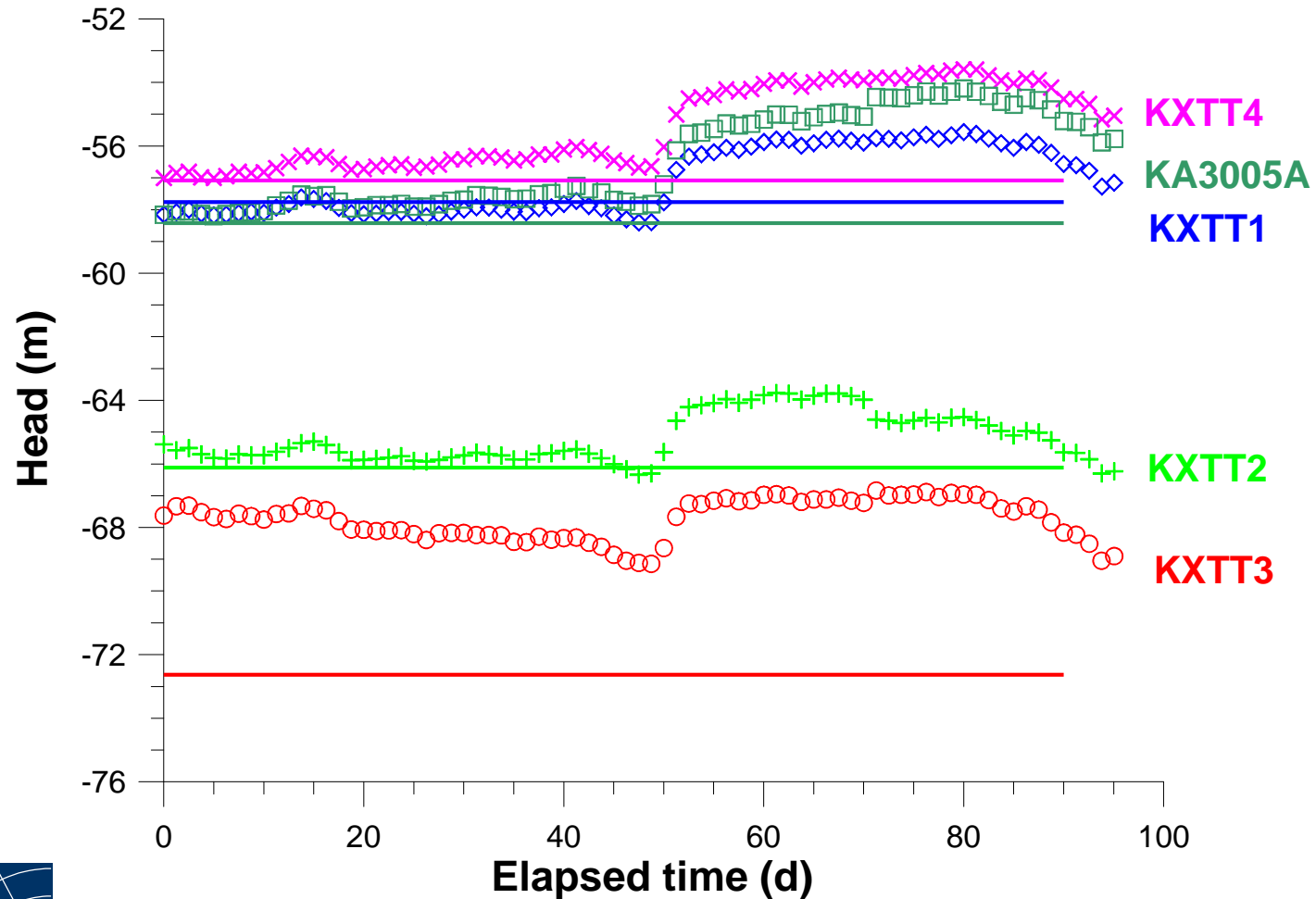
- Feature A is considered as a planar structure
- Model extension: 20 ×20 m
- Mean pipe length: 0.39 m (standard deviation: 0.42 m)
- Slightly anisotropic channel pattern
- Addition of a preferential pathway between KXTT2 and KXTT3

# Hydraulic conductivity

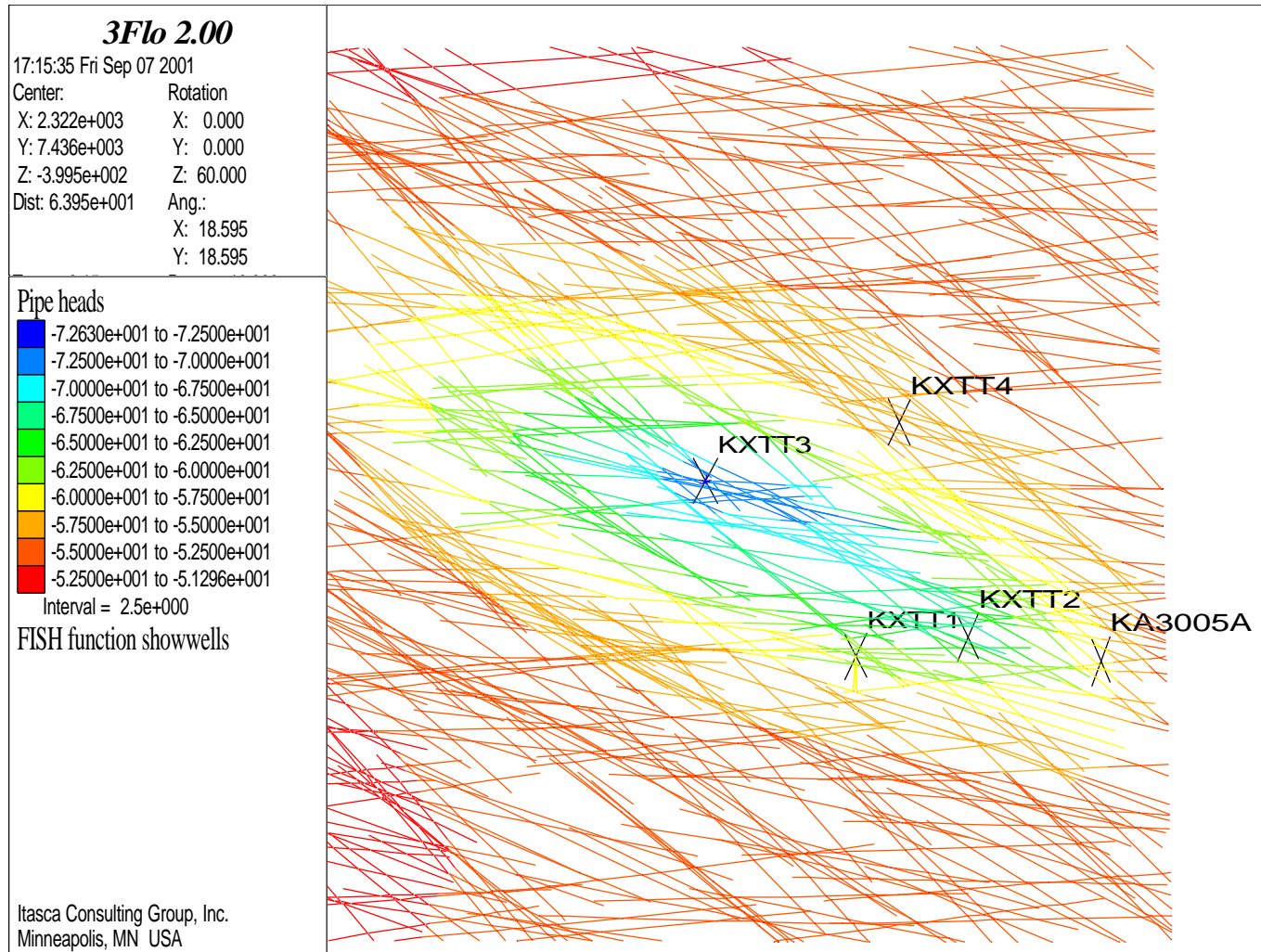


# Calibrated hydraulic heads

Solid lines: Simulated heads



# Hydraulic heads



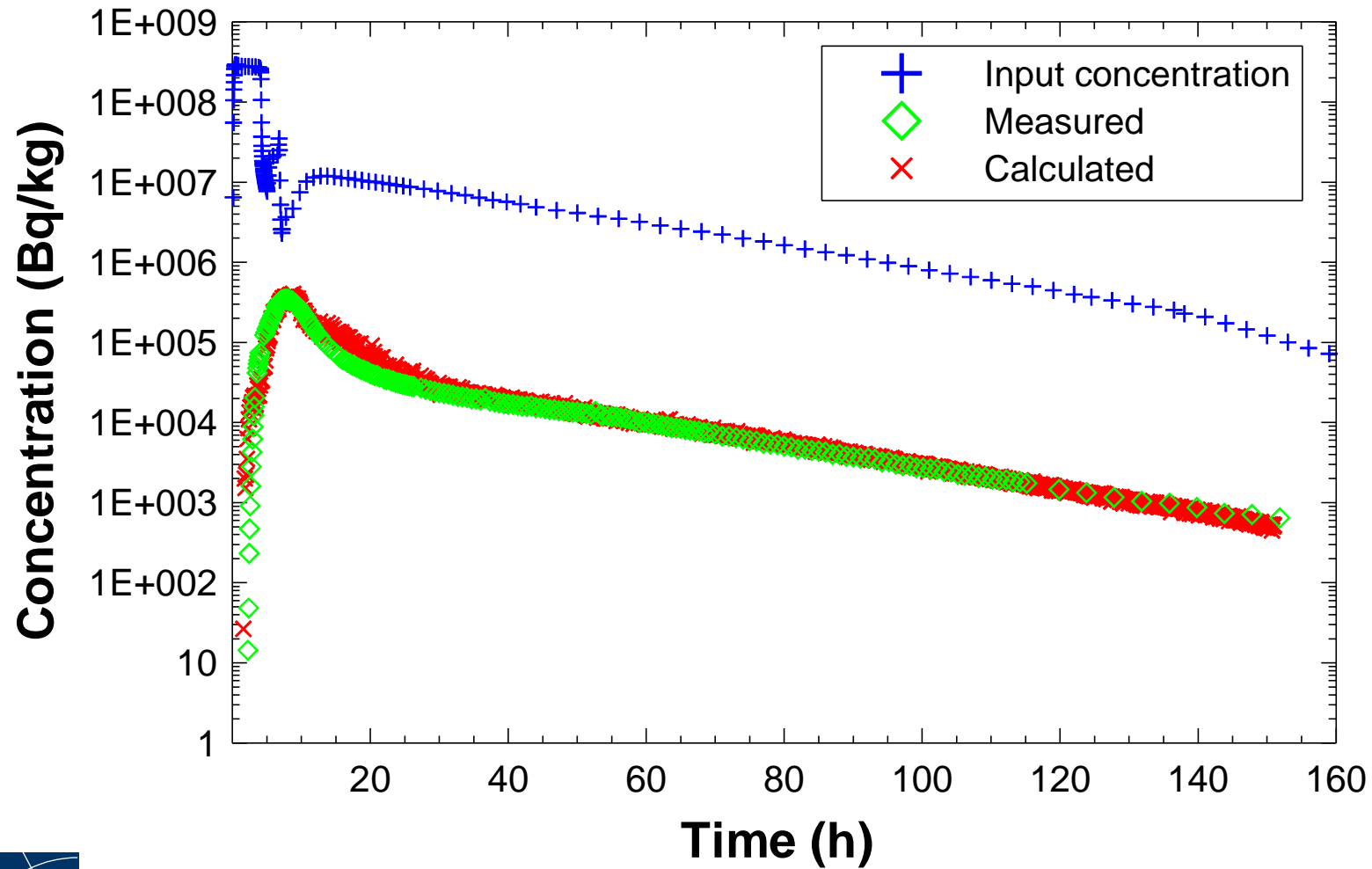
# Transport simulations

- Non-reactive species transport directly simulated
- Dispersivity coefficient decreased to account for perfect mixing at intersections
- Reactive transport based on a  $K_d$  approach
- $K_d$  adjusted to start of breakthrough curve

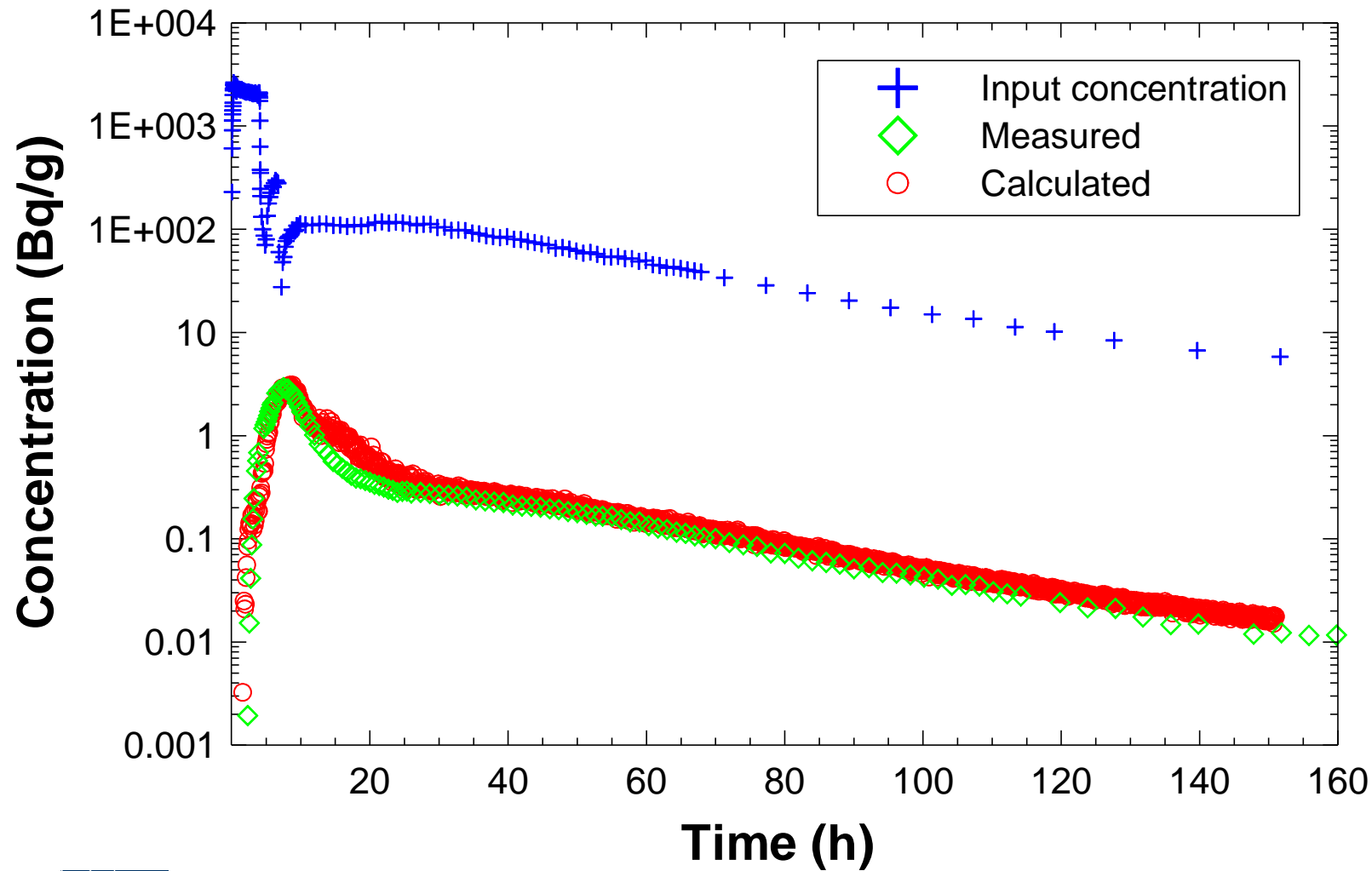
# Parameters for transport

- Dispersion coefficient : 0.1 m
- Diffusion coefficient :  $10^{-9}$  m<sup>2</sup>/s
- Porosity : 0.004
- Rock density : 2700 kg/m<sup>3</sup>
- Up to 50,000 particles in the model

# HTO breakthrough curve

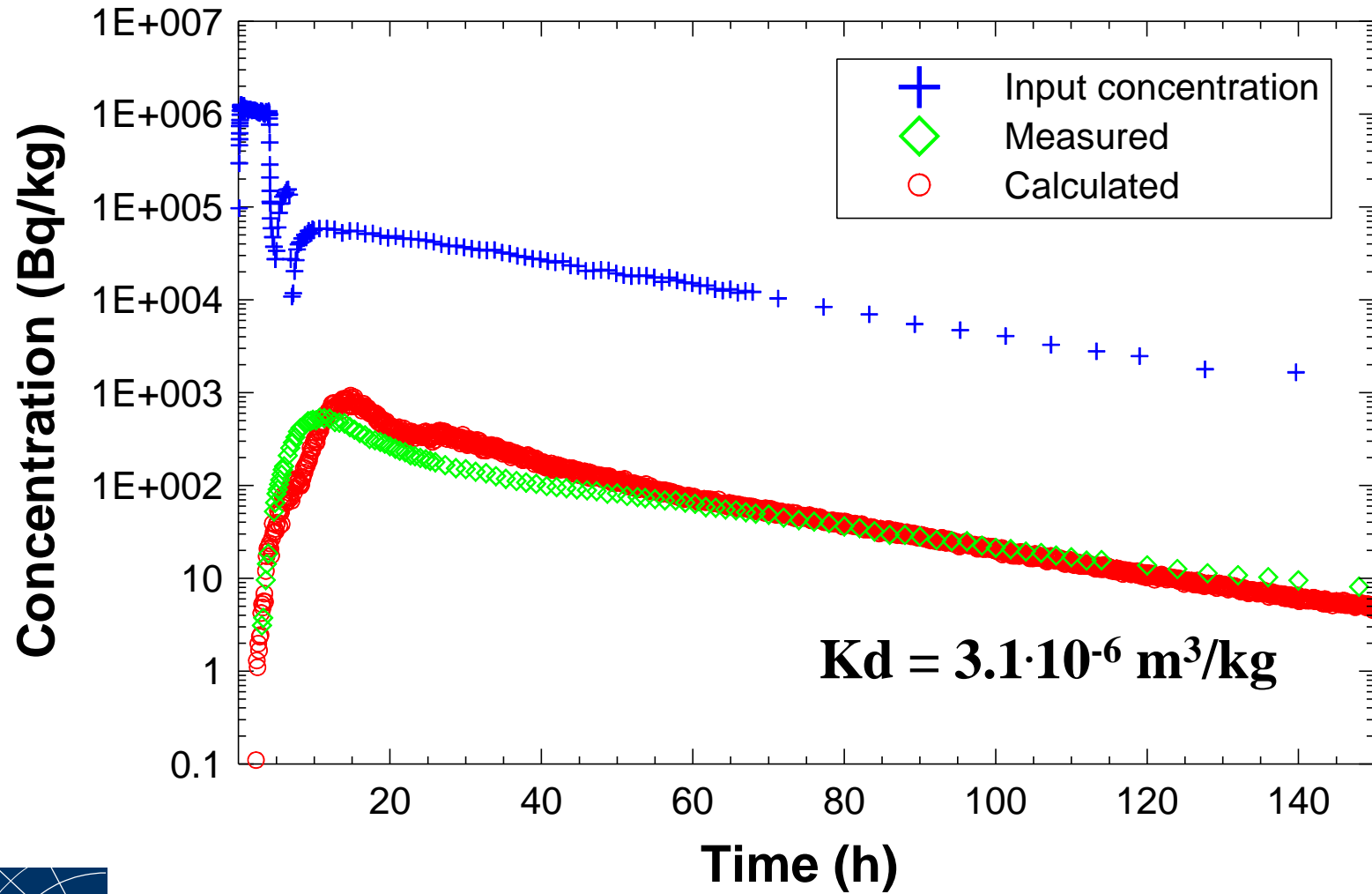


# $^{131}\text{I}$ breakthrough curve

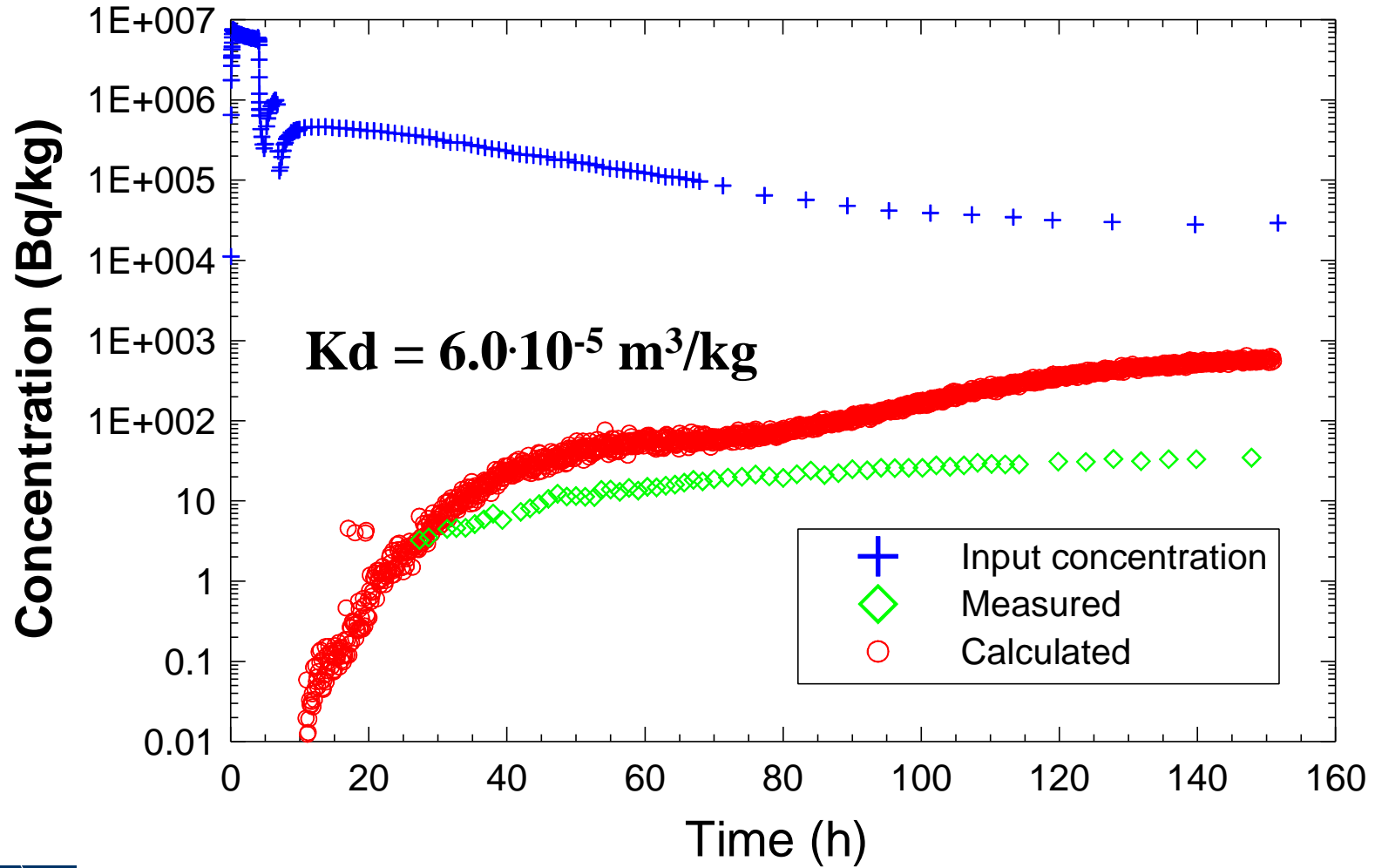




# $^{85}\text{Sr}$ breakthrough curve



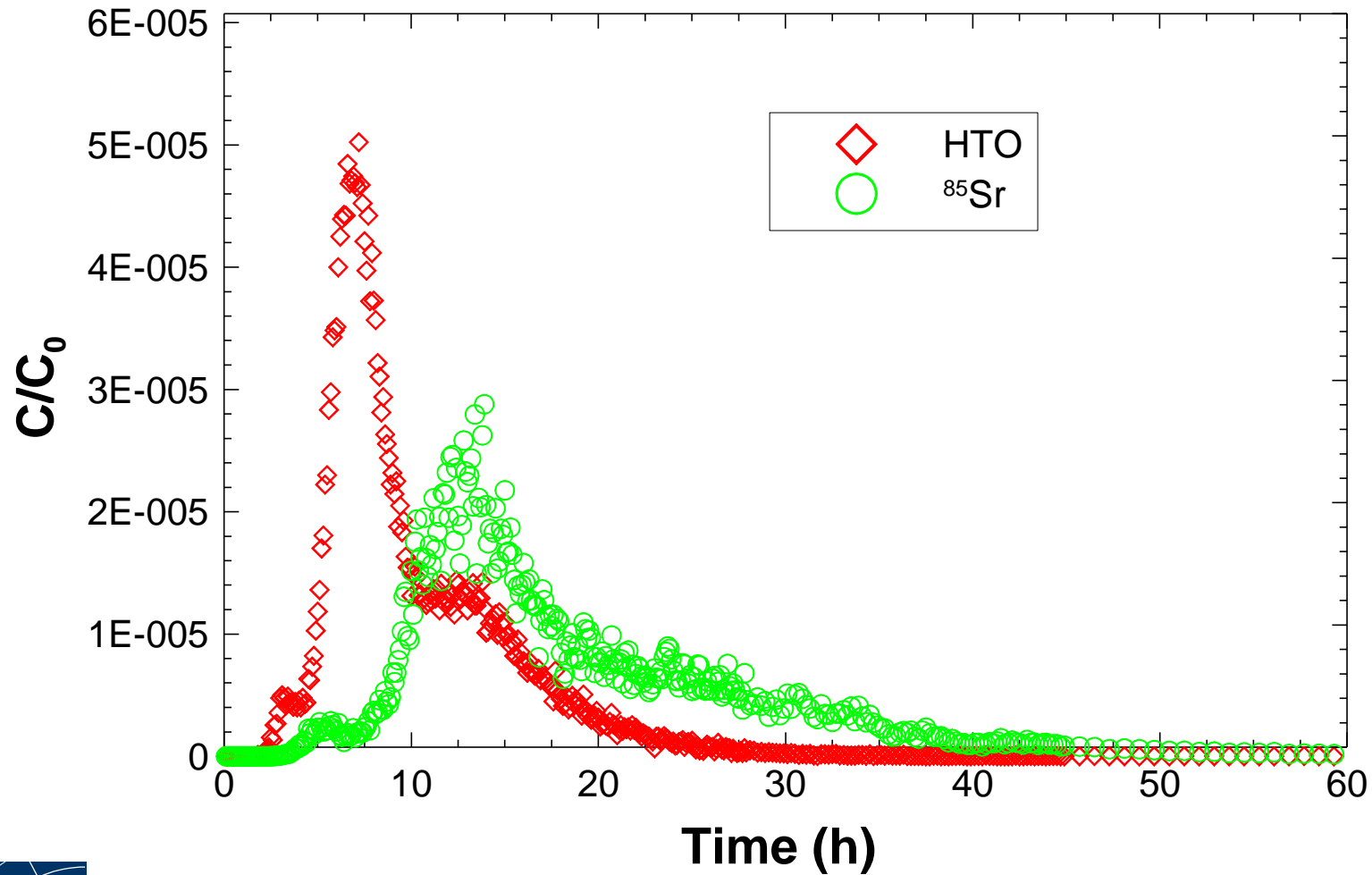
# $^{58}\text{Co}$ breakthrough curve



# TASK A – 2<sup>nd</sup> part

Modelling a unit pulse for a  
Non-reactive tracer and <sup>85</sup>Sr

# Simulated breakthrough curves



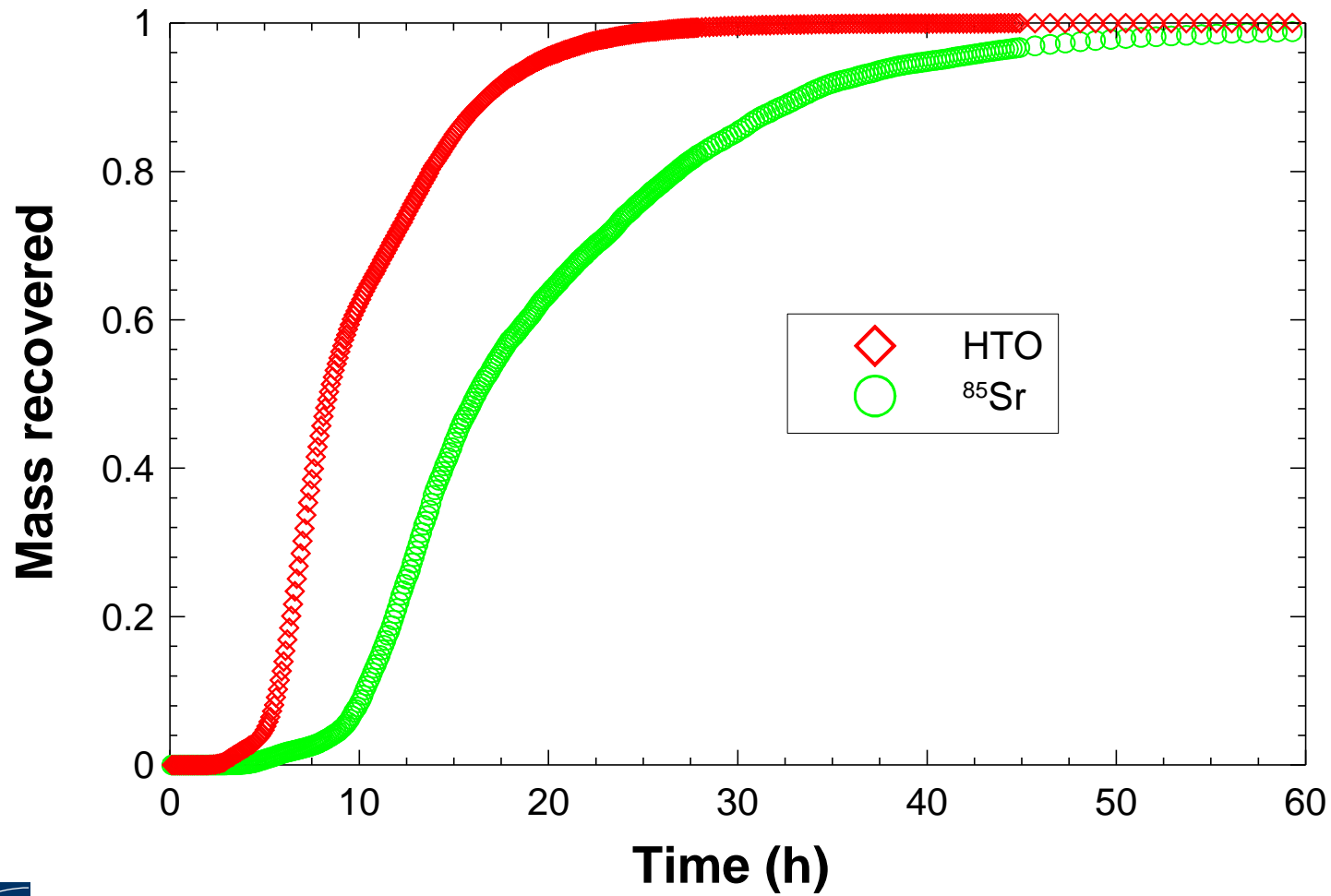
ITASCA  
Consultants s.a.

Ref. 00801r

19

Äspö Task 6 Meeting  
Goslar – 09/11/2001

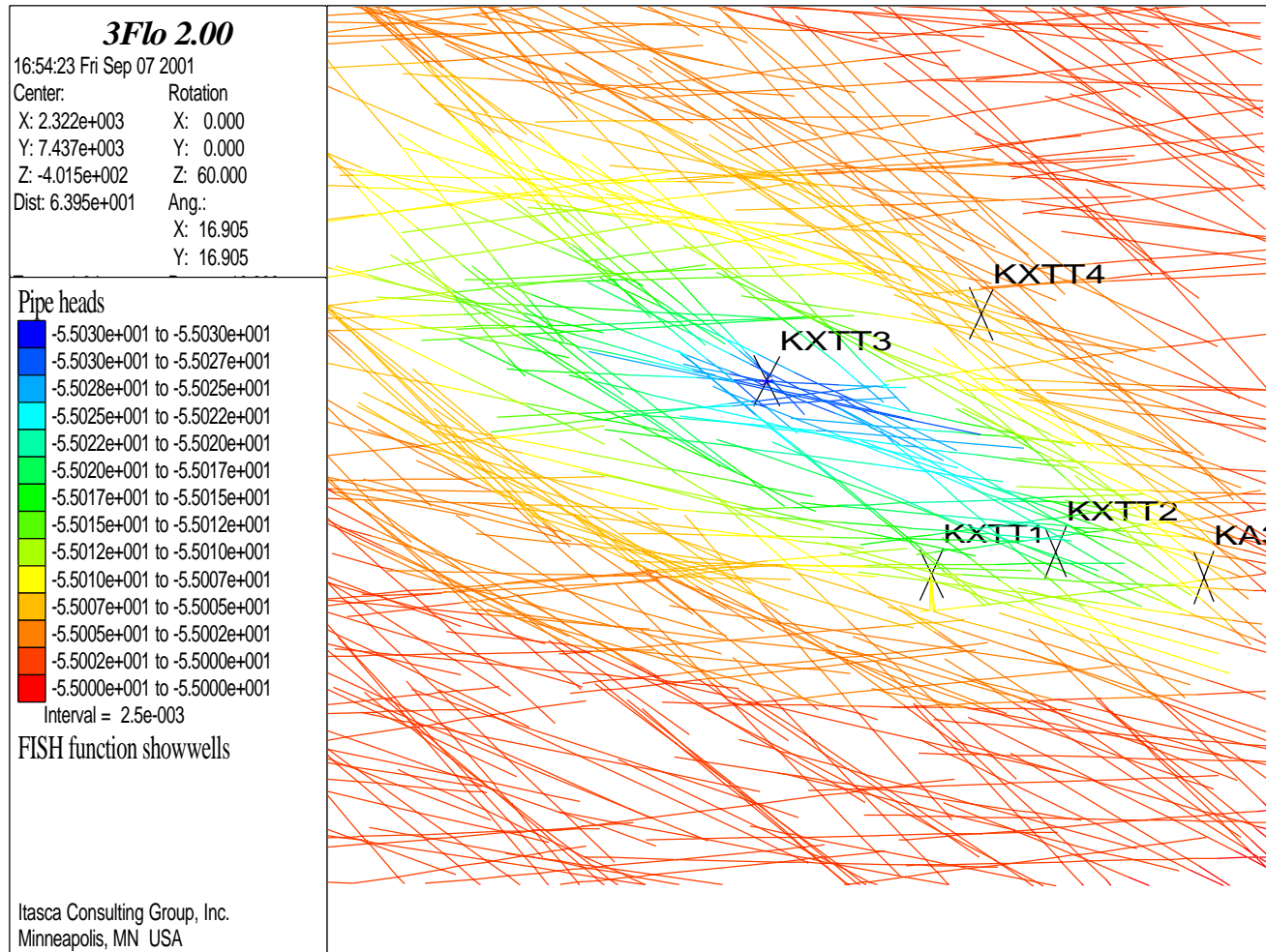
# Cumulated mass recovery



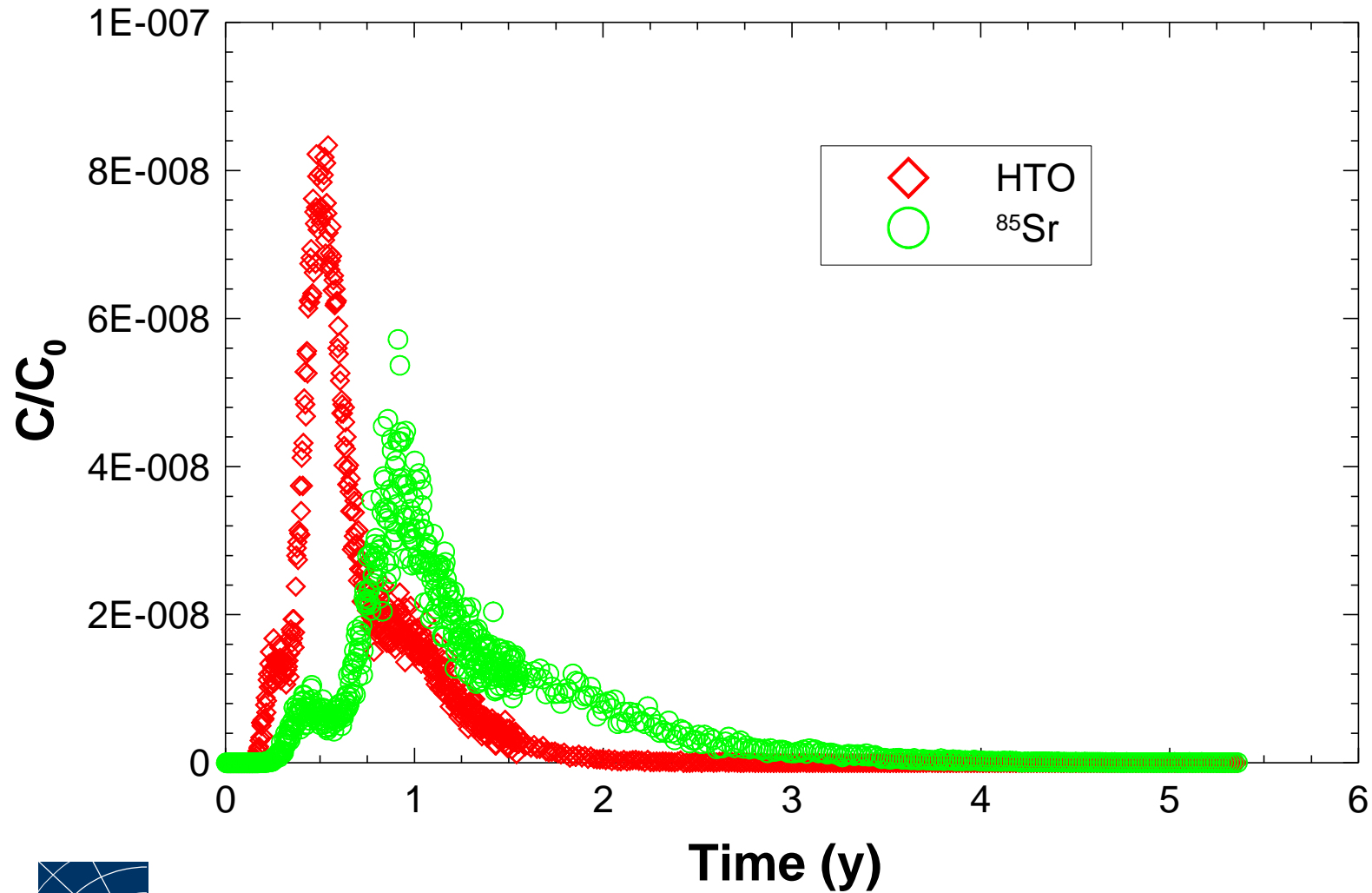
# TASK B

Modelling a unit input pulse for  
a non-reactive tracer and  $^{85}\text{Sr}$

# Hydraulic heads

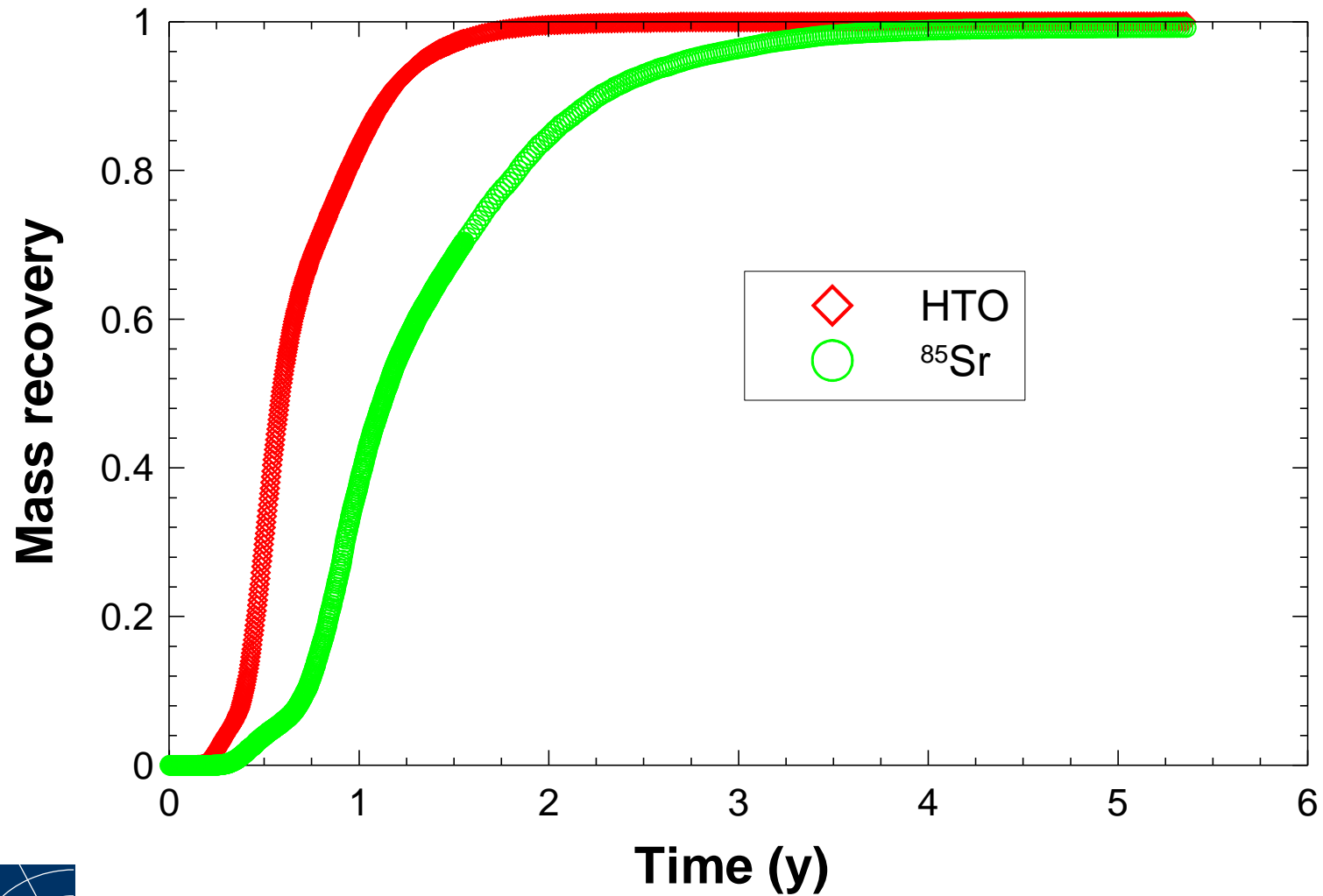


# Simulated breakthrough curves





# Cumulated mass recovery



# Conclusions

- Good calibration of heads
- Good simulation of non-reactive tracers transport
- Only weakly sorbing species are correctly modelled using a  $K_d$  approach

## **Appendix S**

**Simulated Flow and Transport through Two-dimensional Stochastically Heterogeneous Feature A Fracture Plane using a Multi-rate Transport Model**  
**T. Feeney (SANDIA/USDOE)**

**Task 6: A & B**  
**Stochastic Modeling of STT-1b Tracers**  
**Under Pumping and Natural Gradients**

---

*Thomas A. Feeney*  
*and Sean A. McKenna*

**Sandia National Laboratories**  
**Albuquerque, New Mexico USA**



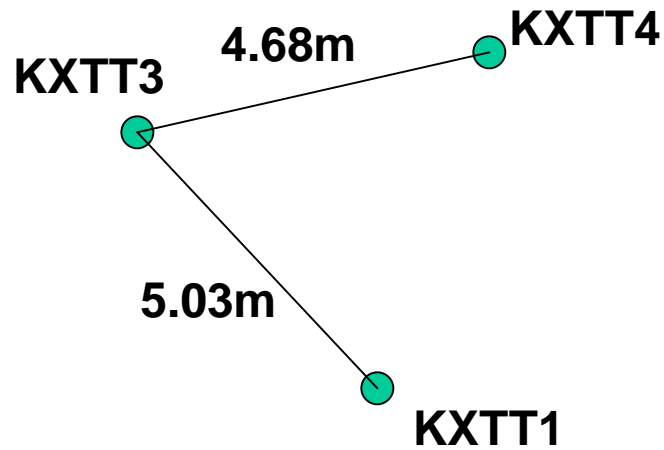
# Objectives

---

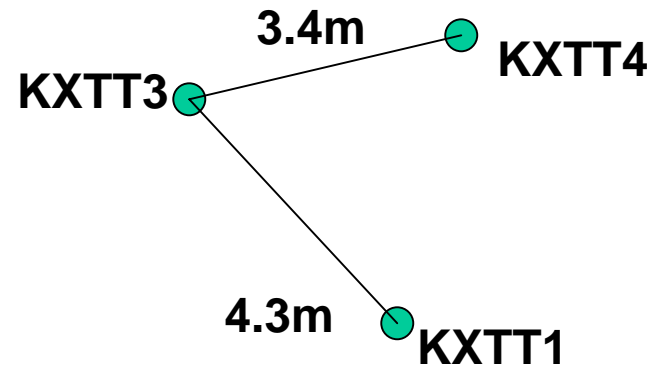
- **Use same conceptual and numerical model to estimate STT-1b tracer tests and predict tracer movement under ambient conditions**
  - Stochastic modeling on 100 T realizations
  - One-dimensional Multirate mass transfer model
  - 5 Tracers: I, Sr, Co, Tc, Am
- **Performance Measures:**
  - Drawdowns, breakthrough curves, release rates,  $t_5$ ,  $t_{50}$ ,  $t_{95}$

# Feature A Geometry

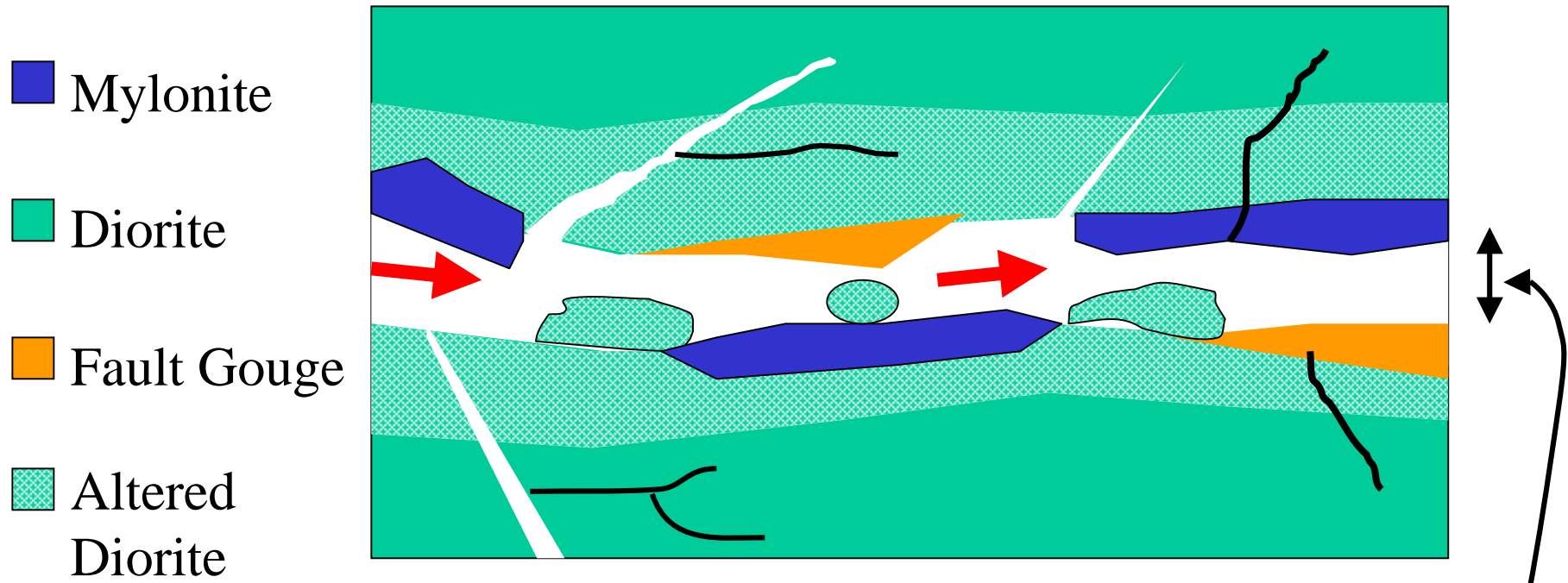
## Three-Dimensional Distances between Intercepts



## Two-Dimensional Distances when Projected onto Feature A Plane



# Multirate Conceptual Model



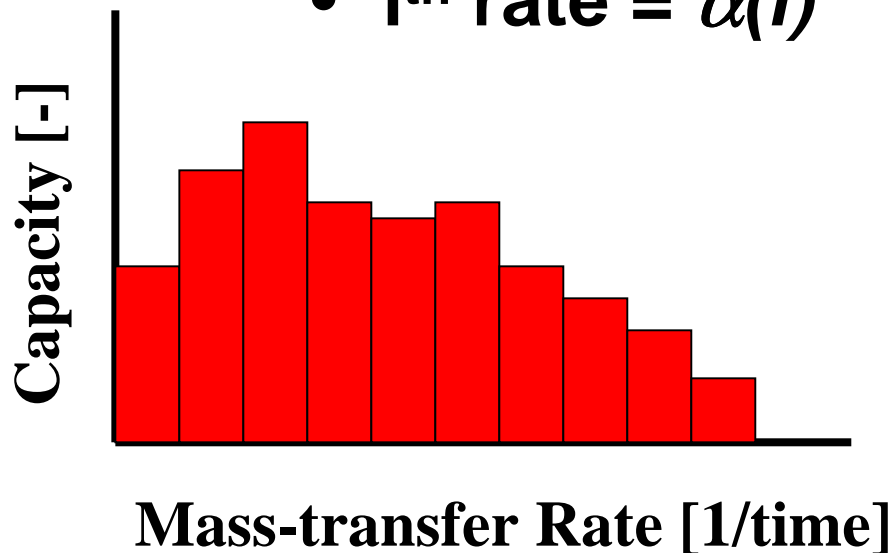
Schematic diagram of Feature A (after Winberg, et al. 1999).

1mm

# Multirate Distribution

- $i^{\text{th}}$  capacity =  $b(i)$
- $i^{\text{th}}$  rate =  $\alpha(i)$

$$\alpha_i = \frac{D_{aq}\tau}{l^2 R_{im}}$$



$$\beta_{tot} = \sum_{i=1}^N b(i)$$

$$\mu = \frac{1}{N} \sum_{i=1}^N \log(\alpha(i))$$

$$\sigma = \sqrt{\frac{1}{N} \sum_{i=1}^N (\log(\alpha(i)) - \mu)^2}$$

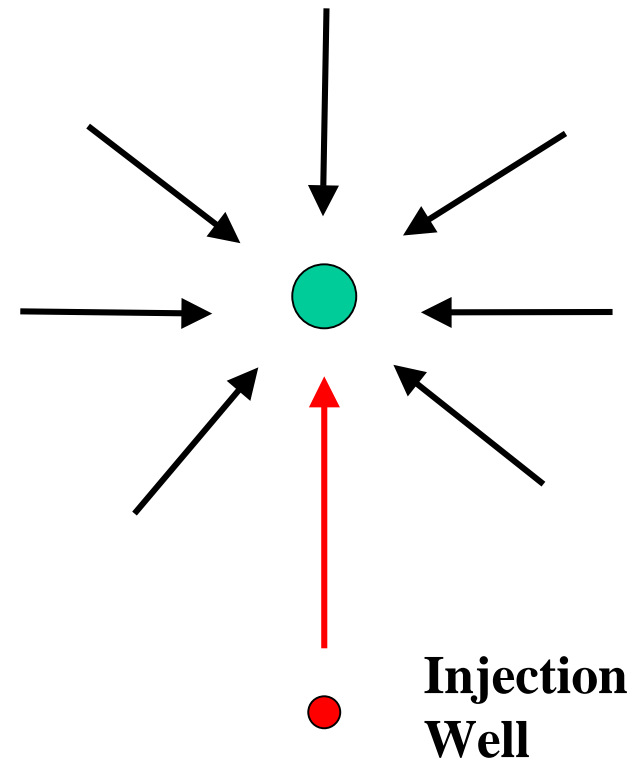


# Dilution Factor

- Dilution factor

$$Dilute = \frac{Q_p}{Q_{inj}}$$

$$Dilute = \frac{Q_p}{Q_{inj}} \frac{1}{RMF}$$



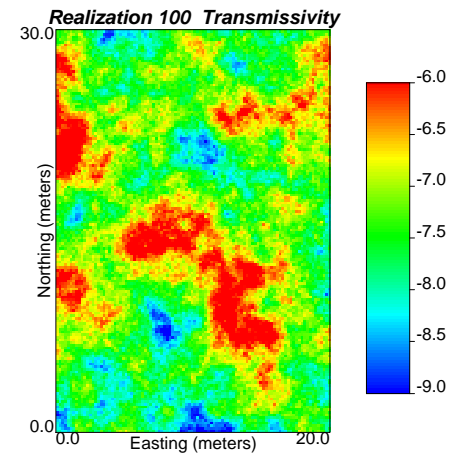
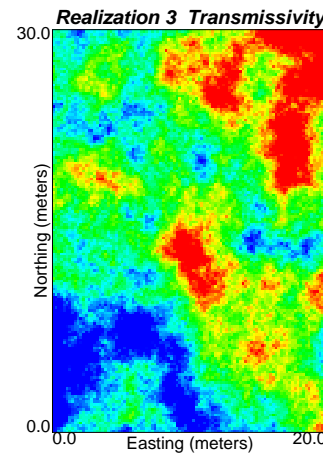
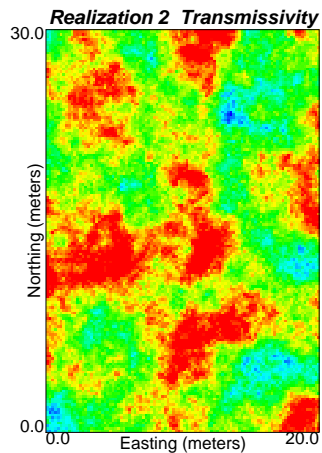
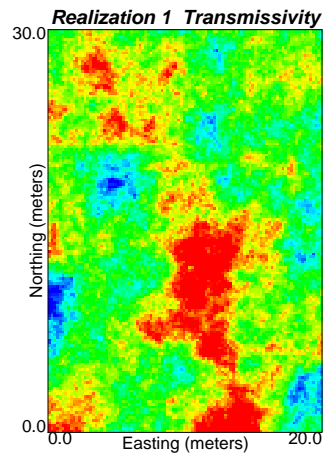
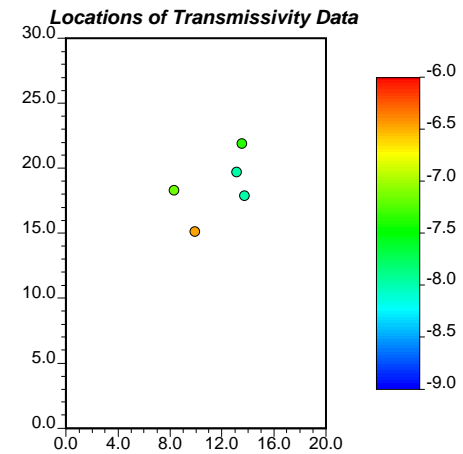
# Modeling Approach

---

- **100 Transmissivity field realizations;  
Heterogeneous fracture**
- **Steady state flow field and particle tracking: travel length, velocity**
- **Estimated transport parameters by inverse modeling of STT-1b inject. and BTC data (I,Sr,Co)**
  - Tc, Am parameters estimated from I, Sr and Co results and laboratory data
- **For ambient conditions case, scaled transport parameters**
- **Transport to 10 years (STT-1b conditions case) and  $10^6$  years (ambient conditions case)**

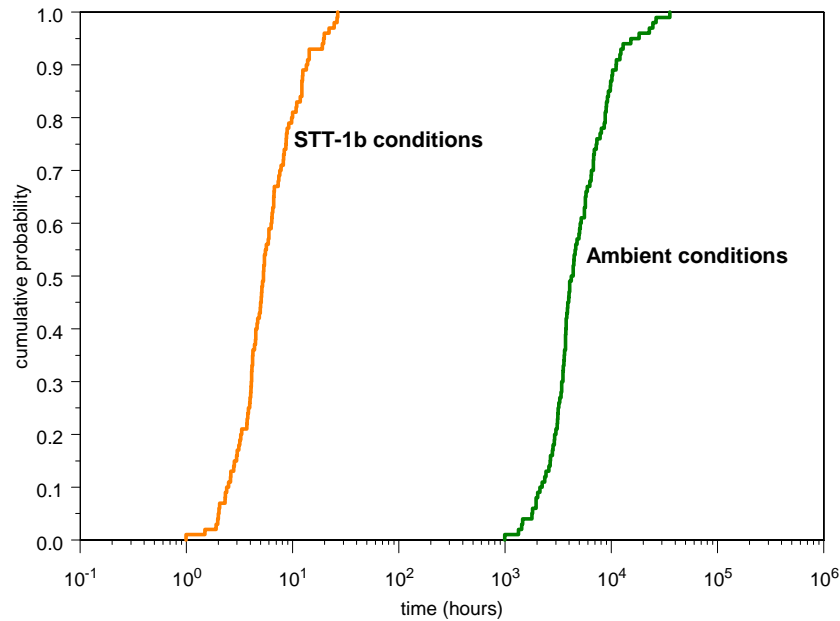
# Transmissivity Fields

Log10 Transmissivity data from 5 boreholes and assumed log-normal distribution ( $\mu=-7.4$ ,  $\sigma=0.7$ ) are used to create 100 T fields using geostatistical simulation

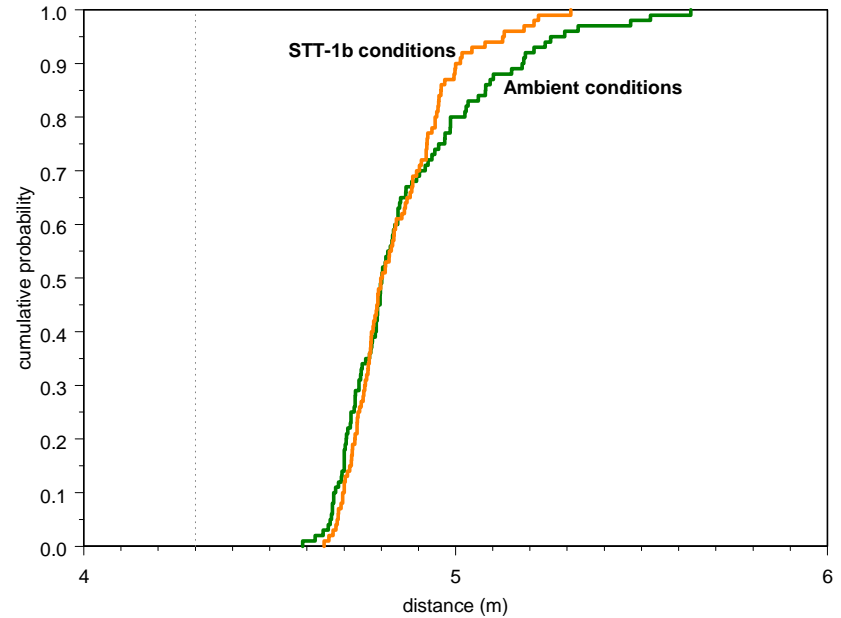


# Travel Times and Lengths – KXTT1 to KXTT3

### Particle Travel Times, KXTT1 to KXTT3



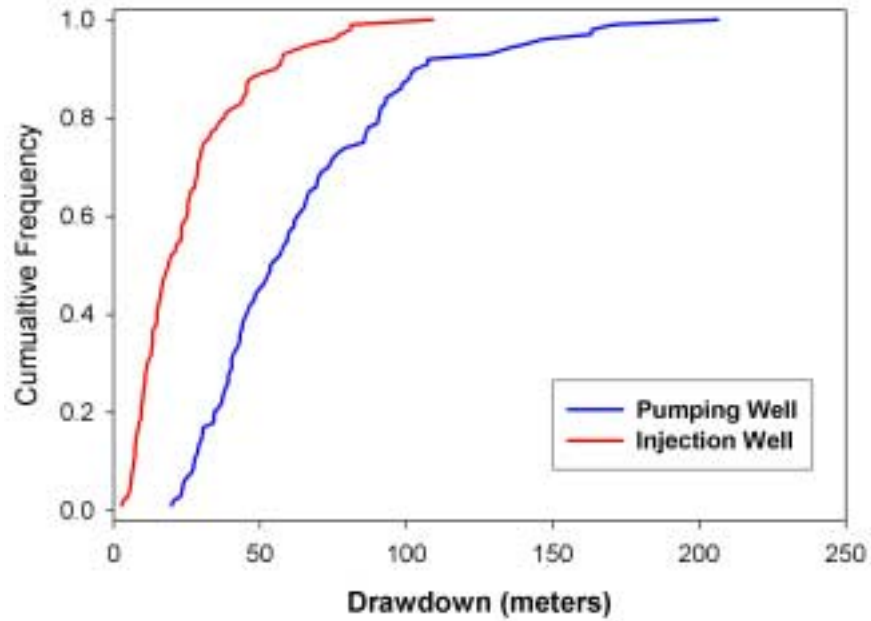
### Particle Pathway Lengths, KXTT1 to KXTT3



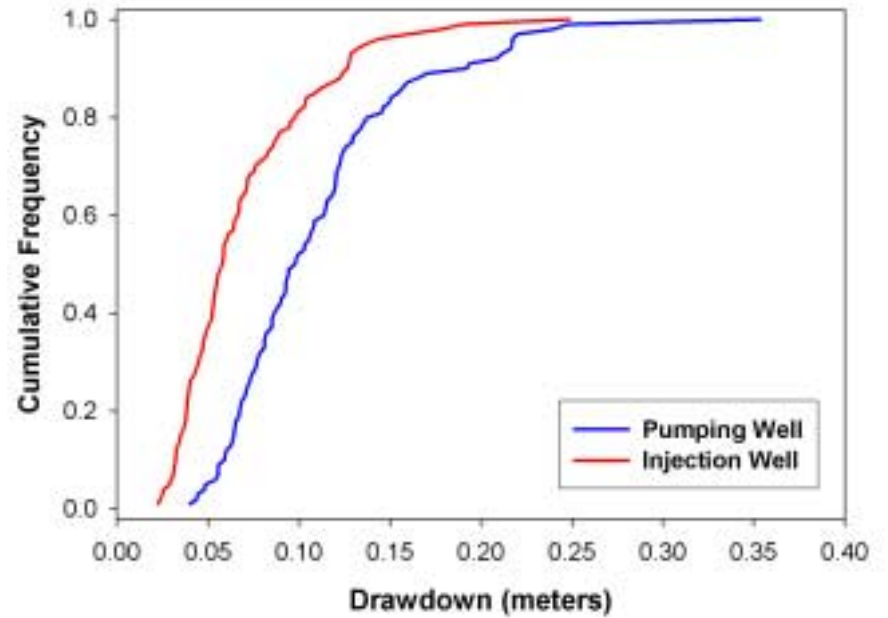
# Drawdowns



### STT-1b Pumping Conditions

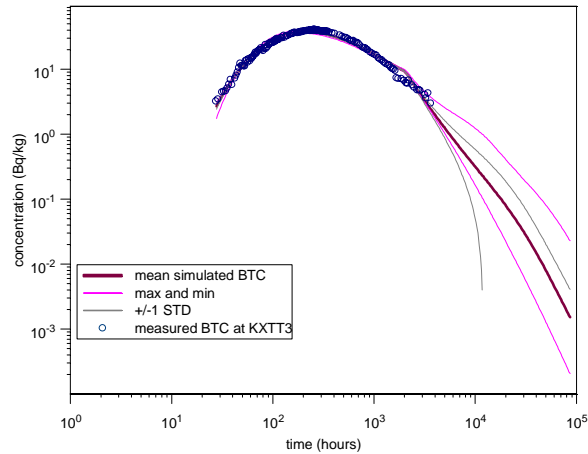


### Ambient Pumping Conditions

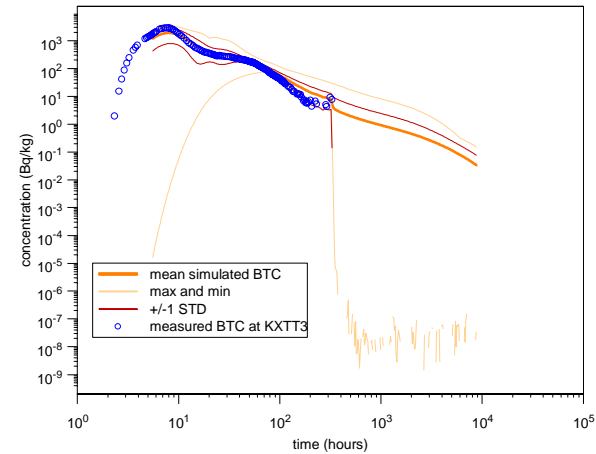


# 10 Year STT-1b Results

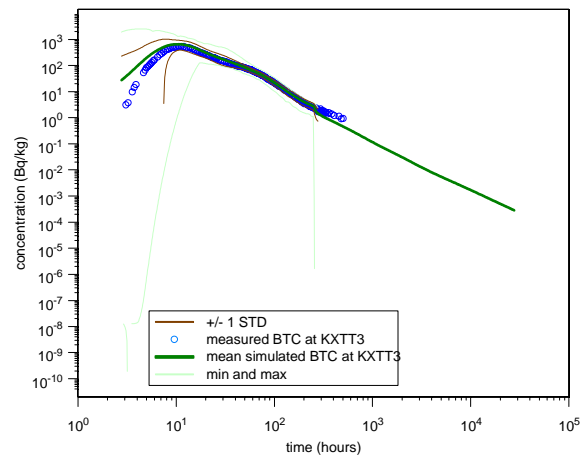
10 Year Simulation with Pumping - Cobalt, STT-1b Injected Source



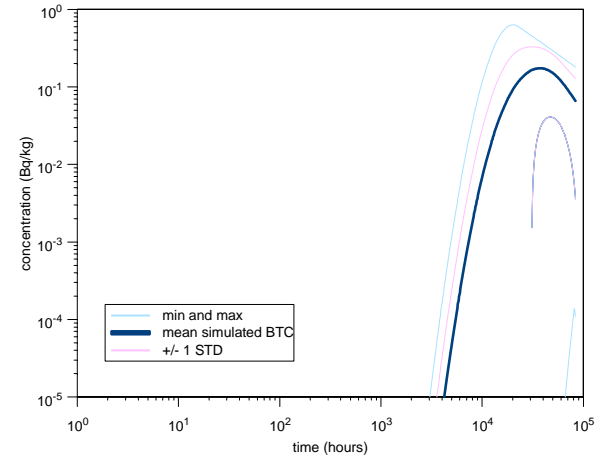
10 Year Simulation with Pumping, Iodine STT-1b Injected Source



10 Year Simulation with Pumping - Strontium, STT-1b Injection

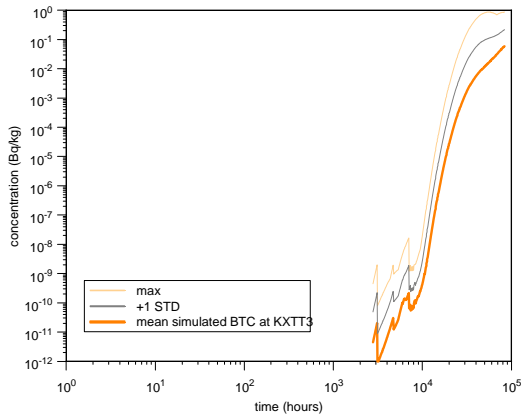


10 Year Simulation with Pumping - Technetium, STT-1b Injection

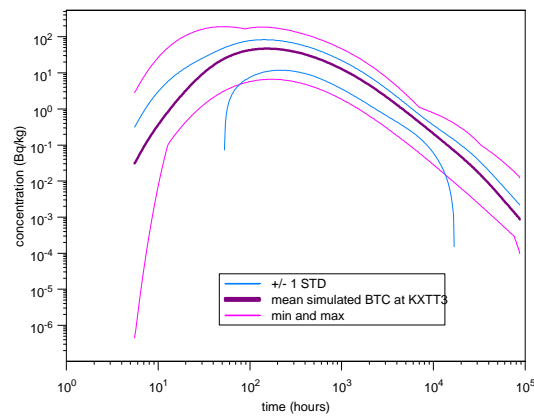


# 10 Yr Dirac Results

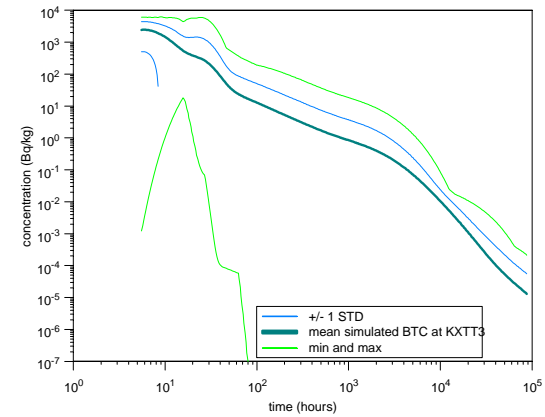
10 Year Simulation - Americium, Dirac Pulse Source



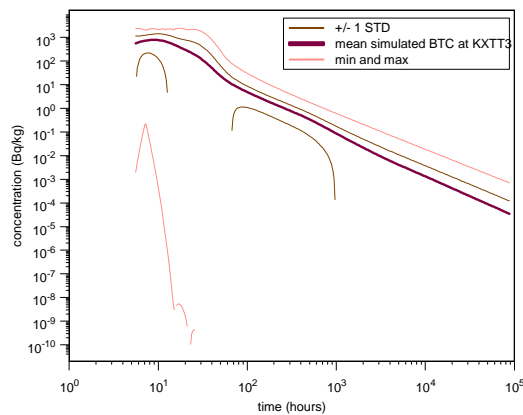
10 Year Simulation - Cobalt, Dirac Pulse Source



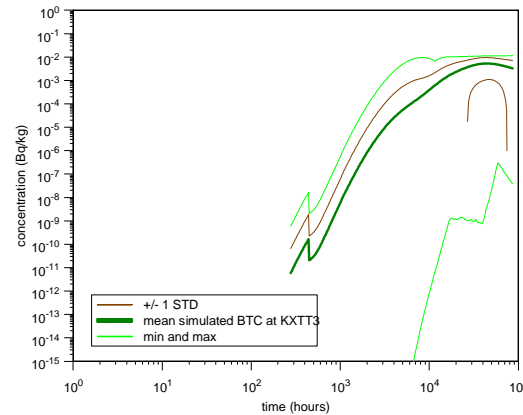
10 Year Simulation - Iodine, Dirac Pulse Source



10 Year Simulation - Strontium, Dirac Pulse Source



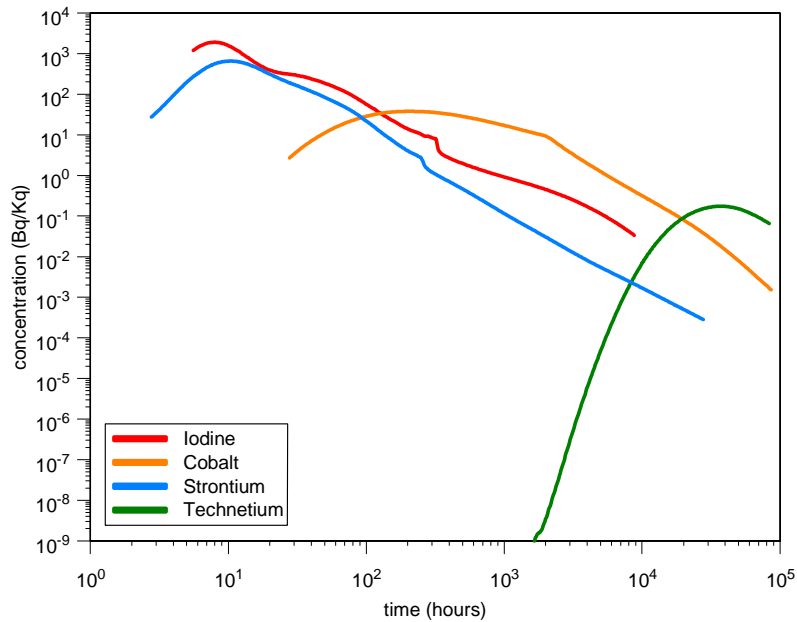
10 Year Simulation - Technetium, Dirac Pulse Source



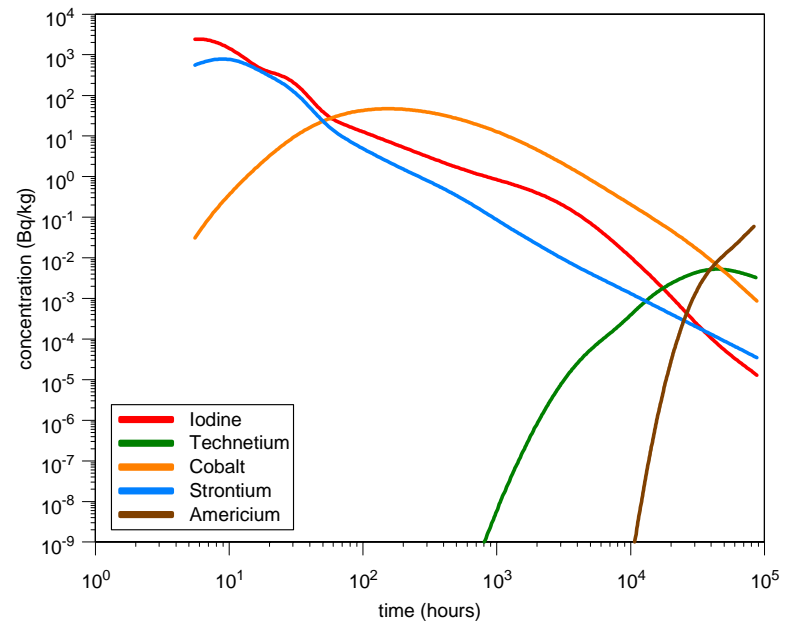
# 10 Yr STT-1b Summary



Mean BTCs over 10 Years at KXTT3, STT-1b Source



Mean BTCs over 10 Years at KXTT3, Dirac Pulse



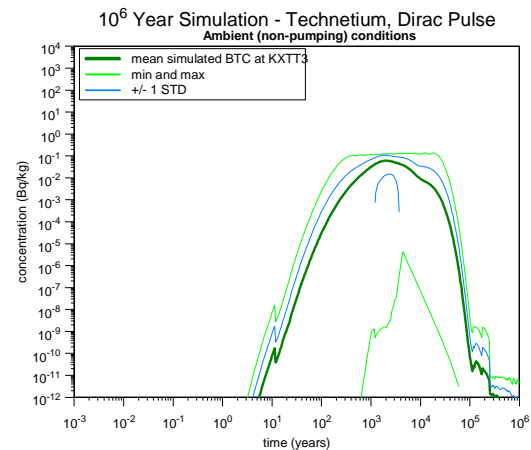
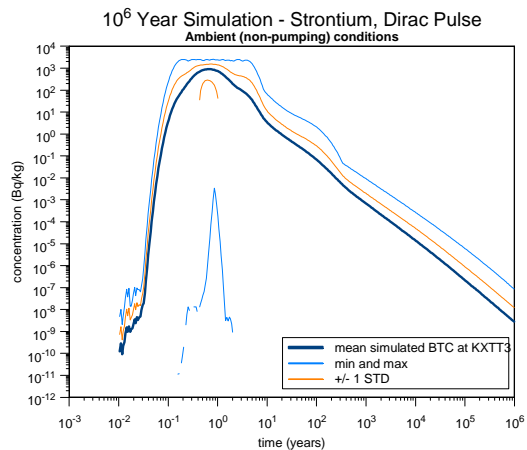
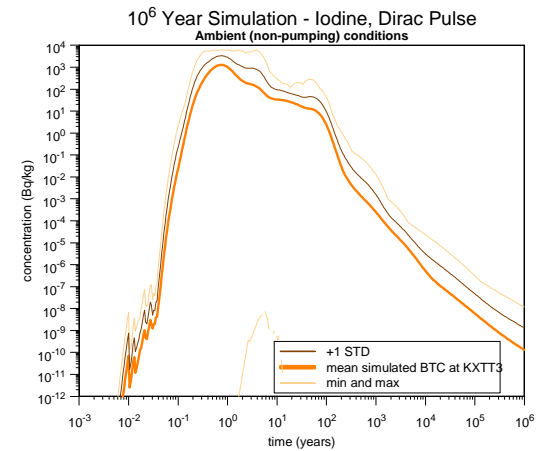
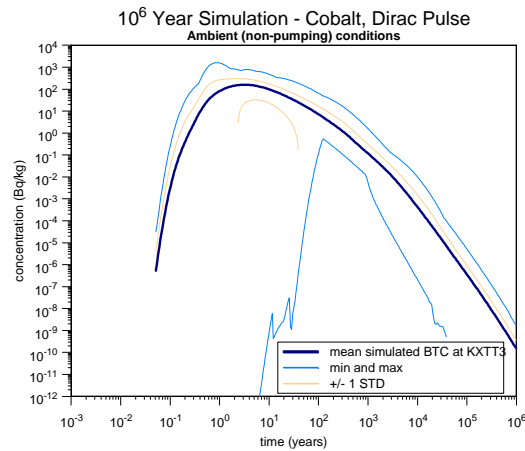
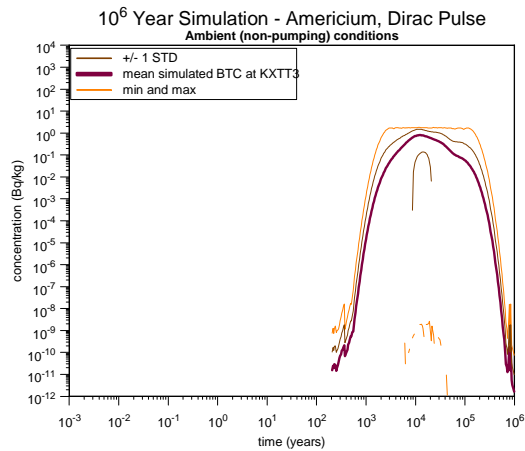


# Scaling Transport Parameters

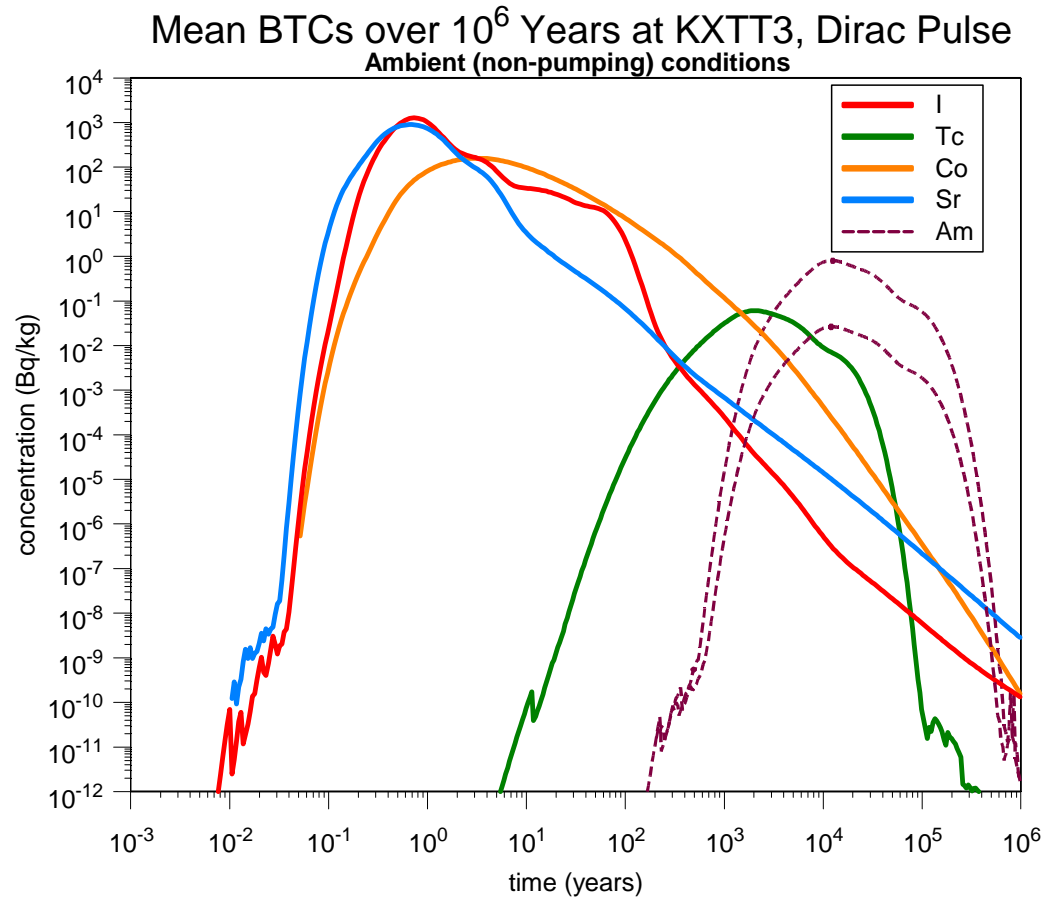
---

- **Decrease mean transfer rate by 1000**
  - Constant ratio of velocity/mass-transfer
- **Decrease capacity by factor of 2**
  - At longer times, mass transfer occurs in lower porosity matrix, thus lower capacity
- **Other parameters kept constant**
  - Dilute,  $R_m$ ,  $s$

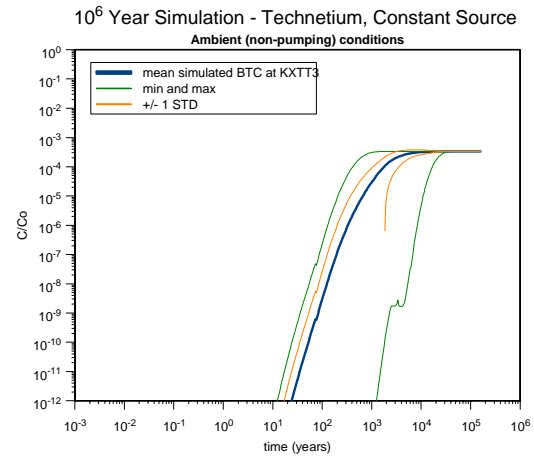
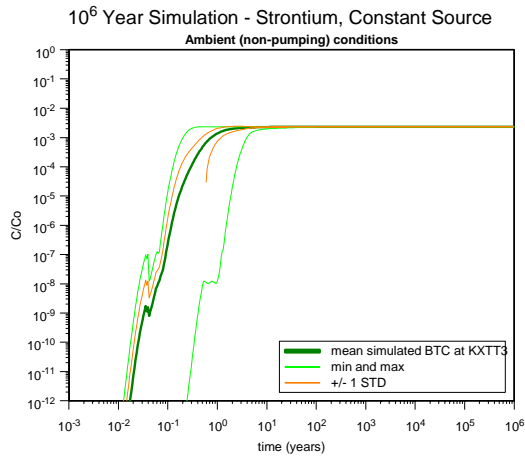
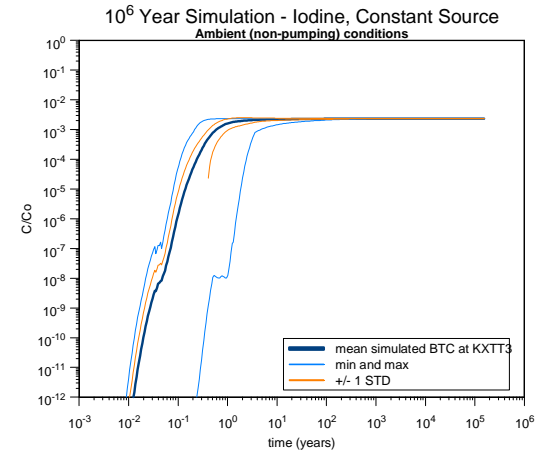
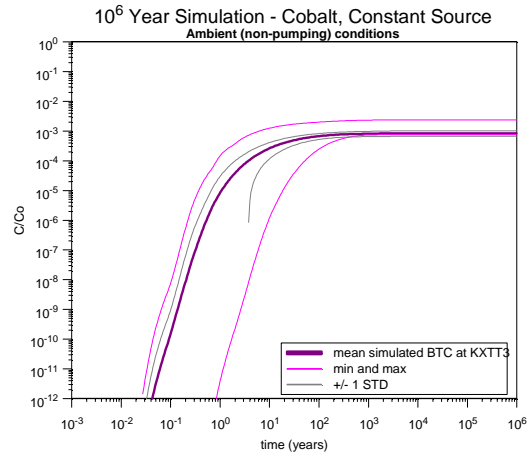
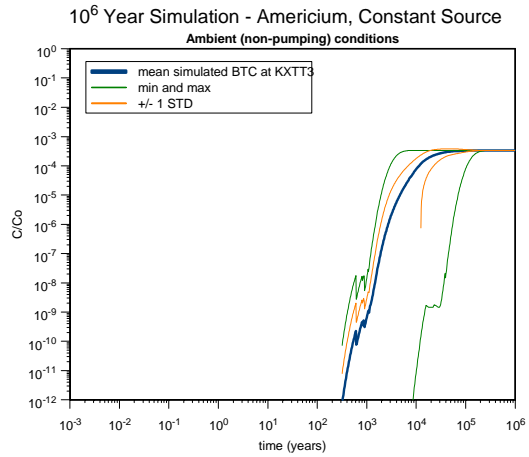
# 10<sup>6</sup> Year Dirac Results



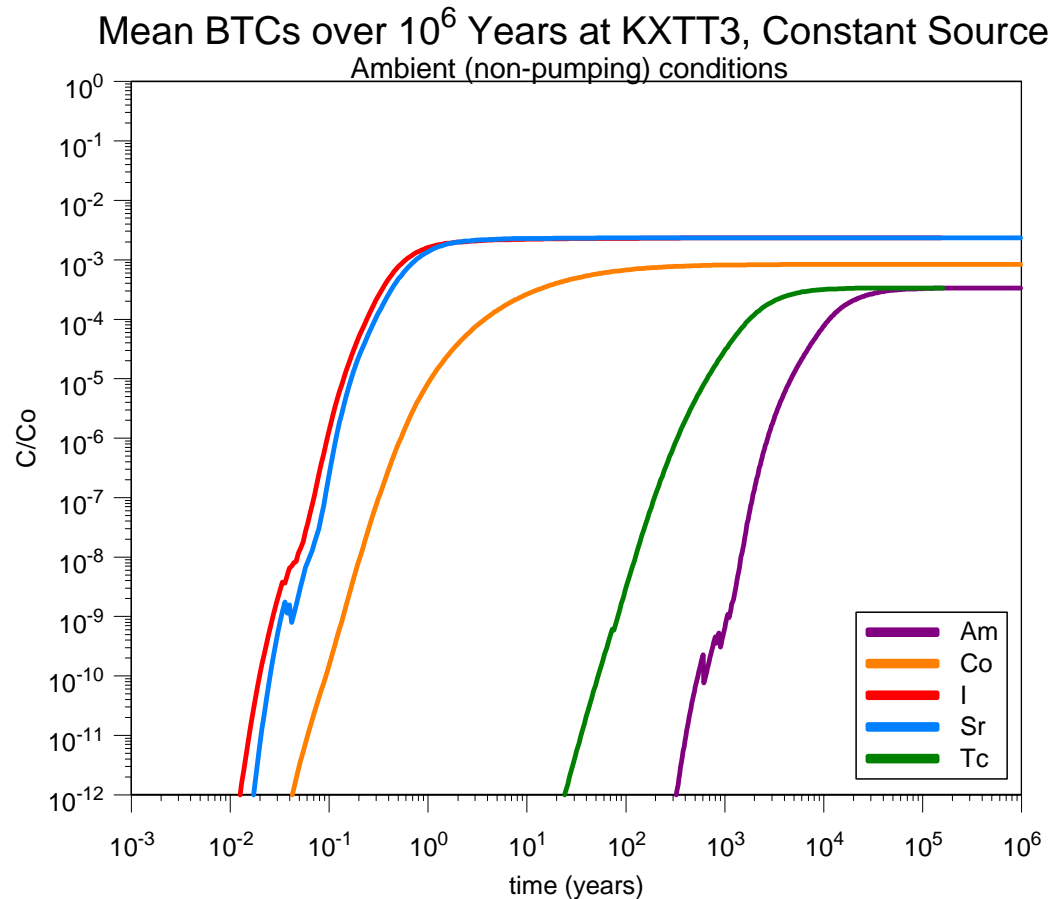
# 10<sup>6</sup> Year Dirac Summary



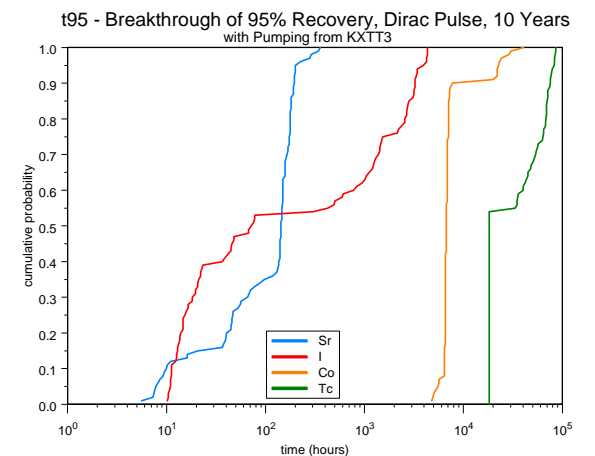
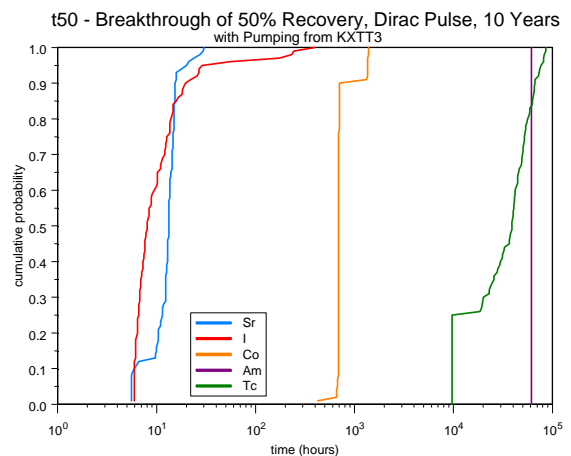
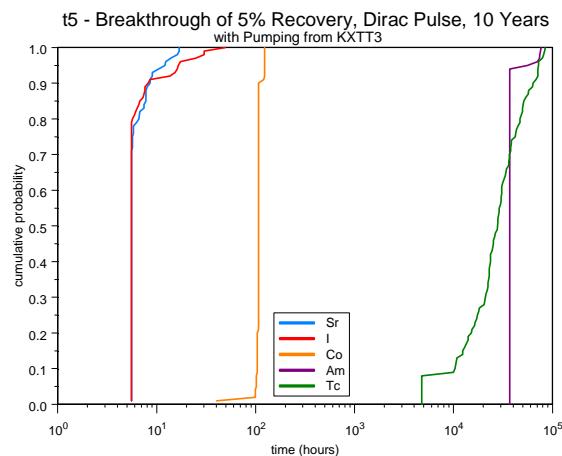
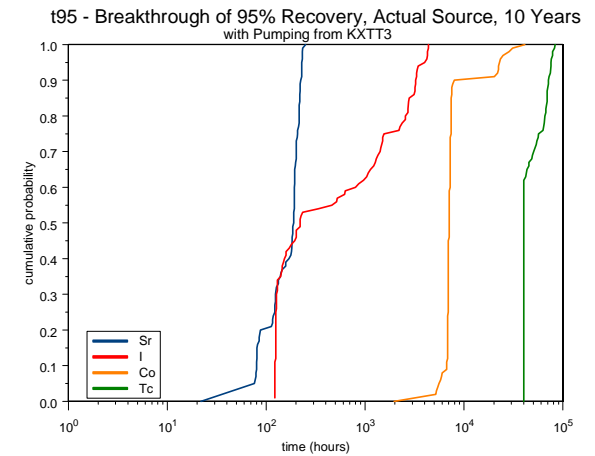
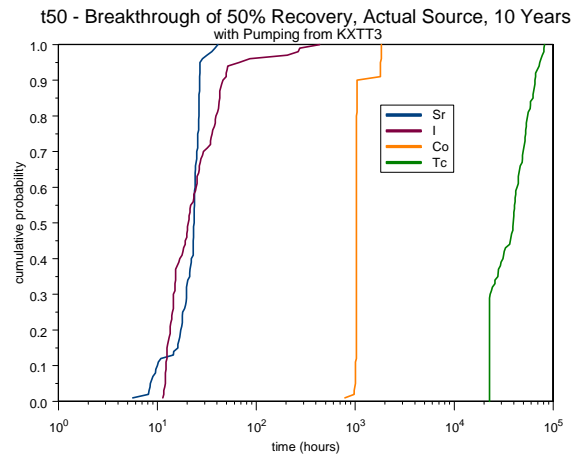
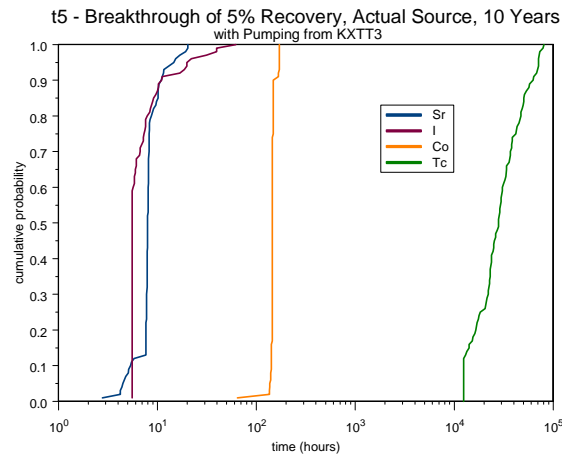
# 10<sup>6</sup> Year Continuous Results



# 10<sup>6</sup> Year Continuous Summary

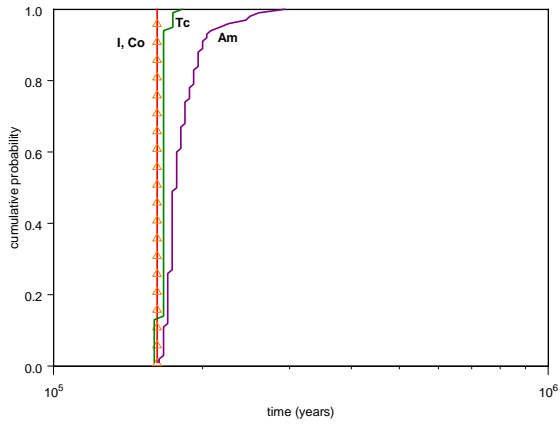


# 10 Year Breakthrough Times

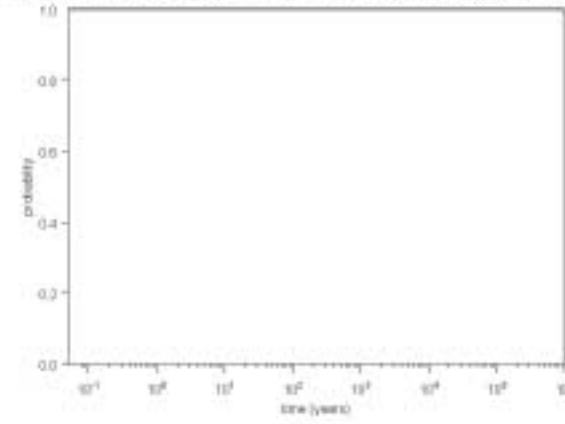


# 10<sup>6</sup> Year Breakthrough Times

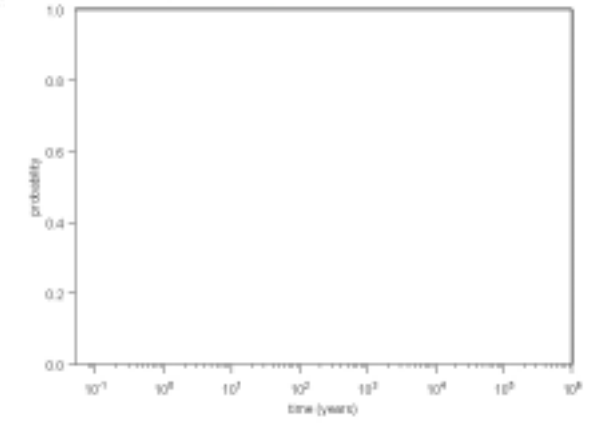
t5 - Breakthrough of 5% Injected Mass, Constant Source, 10<sup>6</sup> Years



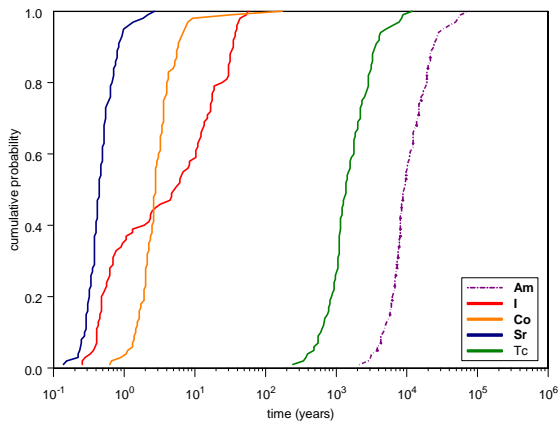
t50 - Breakthrough of 50% Injected Mass, Constant Source, 10<sup>6</sup> Years



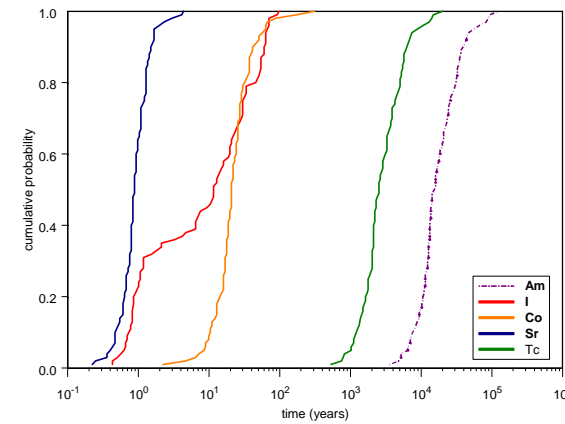
t95 - Breakthrough of 95% Injected Mass, Constant Source, 10<sup>6</sup> Years



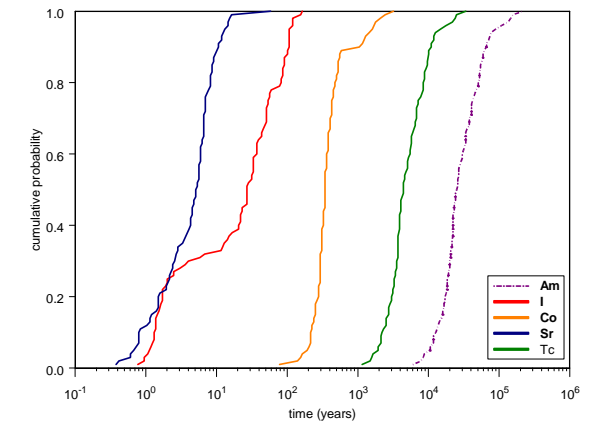
t5 - Breakthrough of 5% Injected Mass, Dirac Pulse, 10<sup>6</sup> Years



t50 - Breakthrough of 50% Injected Mass, Dirac Pulse, 10<sup>6</sup> Years



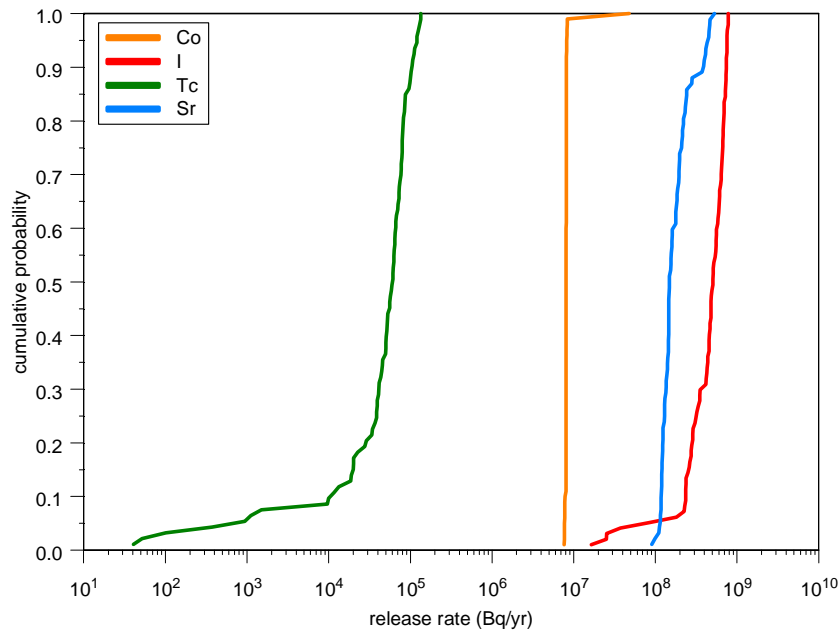
t95 - Breakthrough of 95% Injected Mass, Dirac Pulse, 10<sup>6</sup> Years



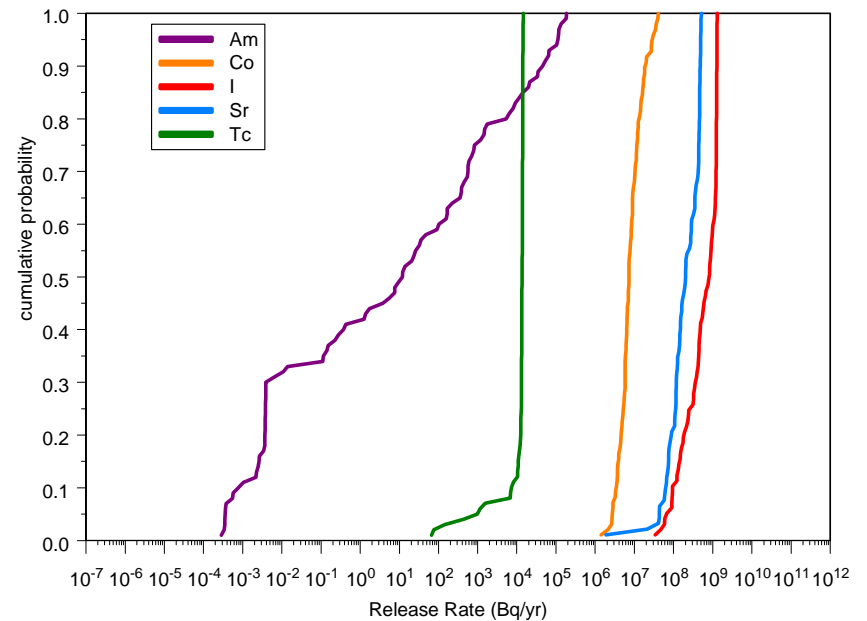
# 10 Year, Maximum Release Rates



Maximum Release Rate, 10 Year Simulation, STT-1b Source



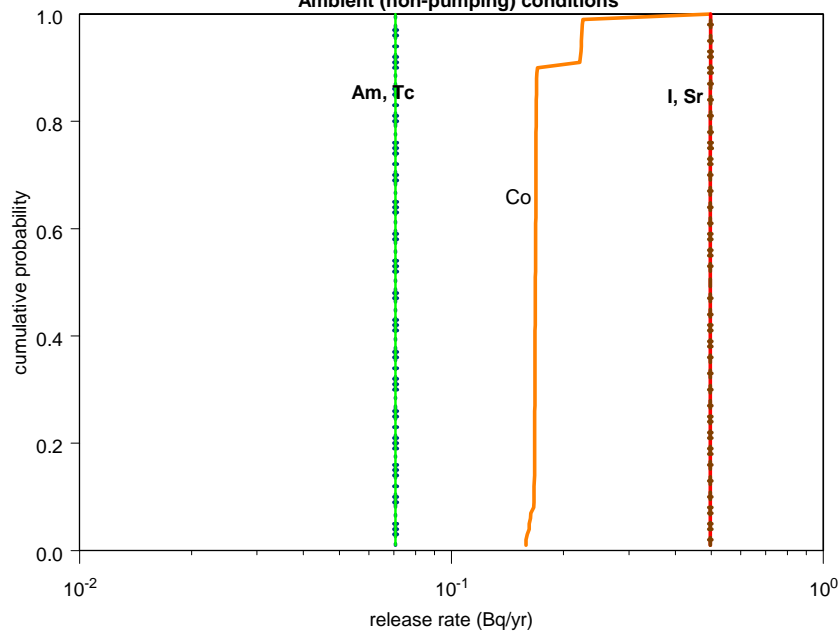
Maximum Release Rate, 10 year Simulation, Dirac Source



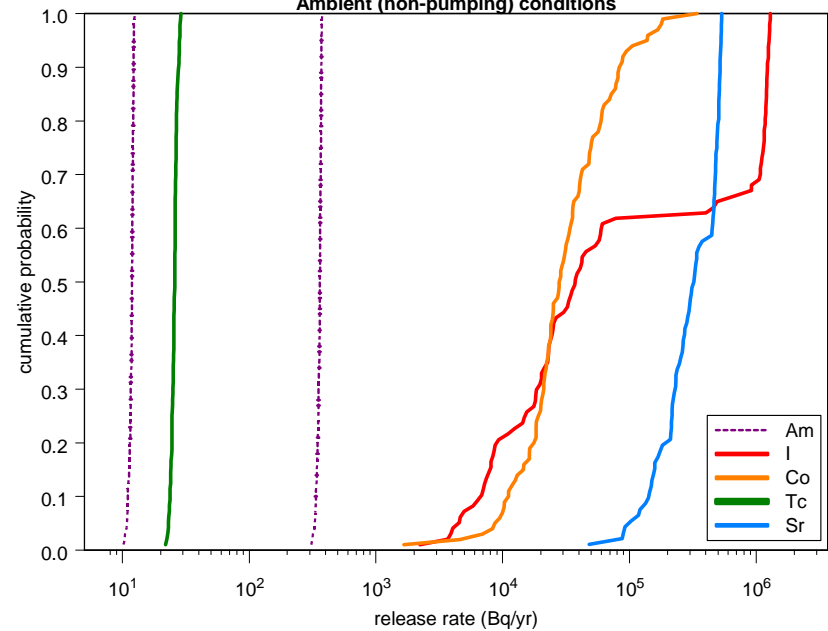


# 10<sup>6</sup> Year Maximum Release Rates

Max Release Rates at KXTT3, 10<sup>6</sup> Year Simulation, Constant Source  
Ambient (non-pumping) conditions



Max Release Rates at KXTT3, 10<sup>6</sup> Year Simulation, Dirac Pulse  
Ambient (non-pumping) conditions



# Summary

---

- **STT-1b and Ambient conditions modeled stochastically**
- **Applied one multirate model to both STT-1b and ambient conditions**
- **Accurately estimated observed data**
- **Consistently estimated longer time scale transport**
  - **Predictions dependent on scaling assumptions**

## **Appendix T**

**Task 6A and 6B Orientations and preliminary results.**  
**C. Grenier (CEA/ANDRA)**

# TASK 6A and 6B : Orientations and preliminary results

C. Grenier  
(Commissariat à l'Énergie Atomique)

15th Task Force Meeting in Goslar, September 11-13 2001



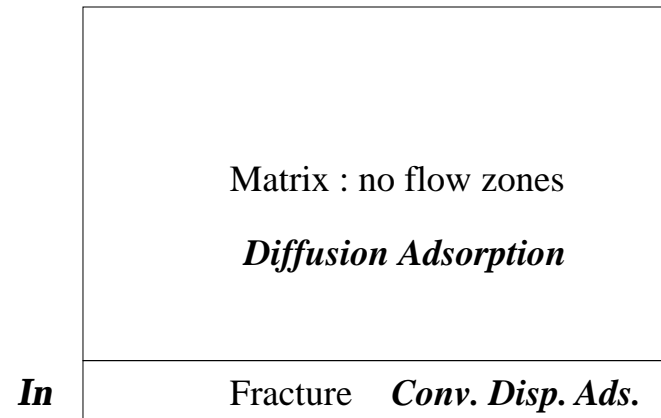
DM2S/SFME/MTMS



## Overview

- *Task 6A*
  - ▷ Basic approach and calibration
  - ▷ Model improvements considered
- *Task 6B*
  - ▷ Situation as compared with Task 6A
  - ▷ Modeling line
  - ▷ Preliminary analysis based on basic approach





$$R_d \frac{\partial C_m}{\partial t} = D_p \Delta C_m.$$

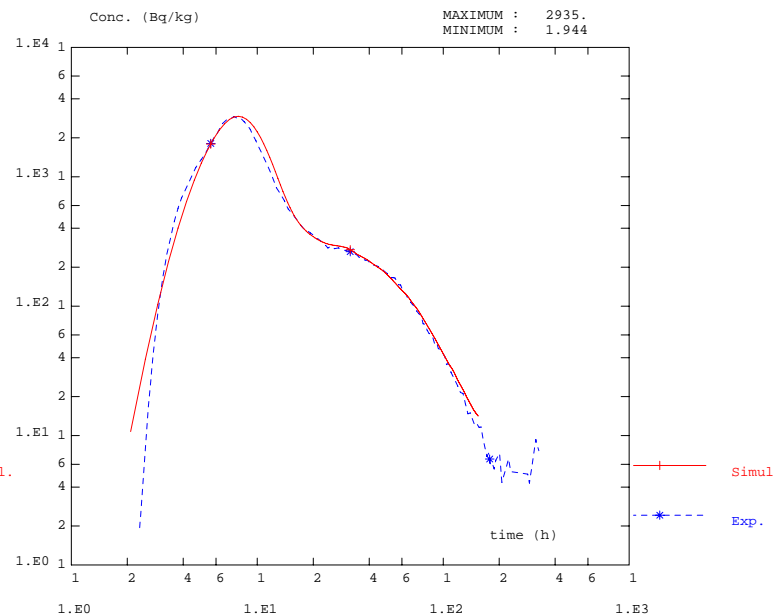
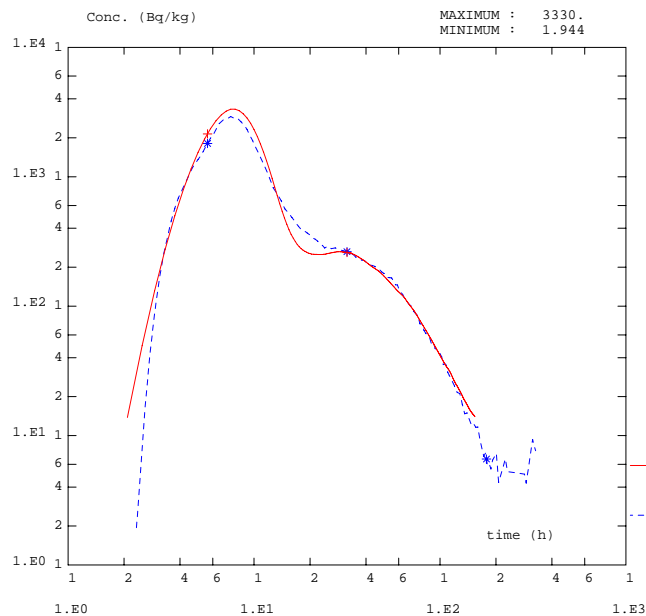
$$\text{Out } R_a \frac{\partial C_{fr}}{\partial t} = D_L \Delta C_{fr} - \vec{U} \vec{\nabla} C_{fr} + a_w \omega D_p \frac{\partial C_m}{\partial z},$$

## Basic approach : 1D model

- Captures main transport features (conv., disp., diff. zones)
- 4 parameter model (Maloszewski & Zuber 85)
  - ▷ (Peclet, conv. time, penetration depth, exchange coeff.)
- Simulation with CASTEM2000 code (Eulerian or Lagrangian)



# Calibration : most basical model (PA) ?



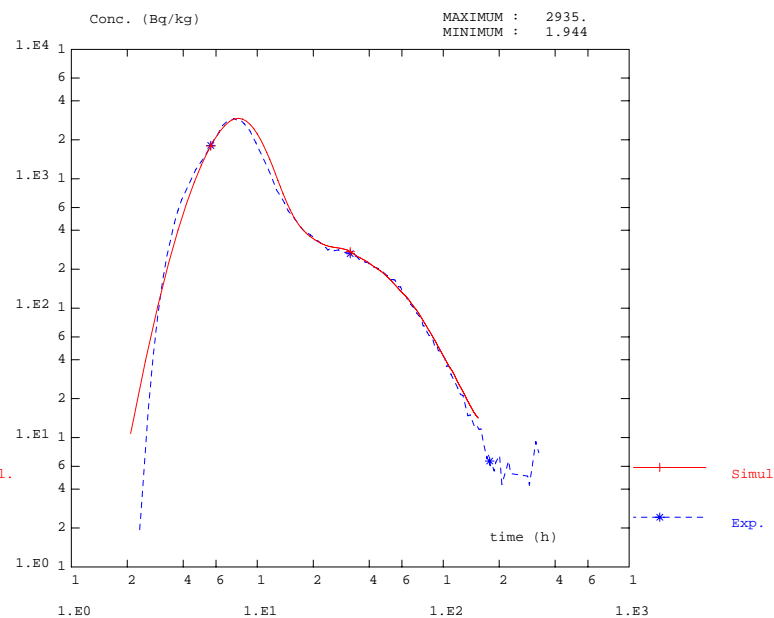
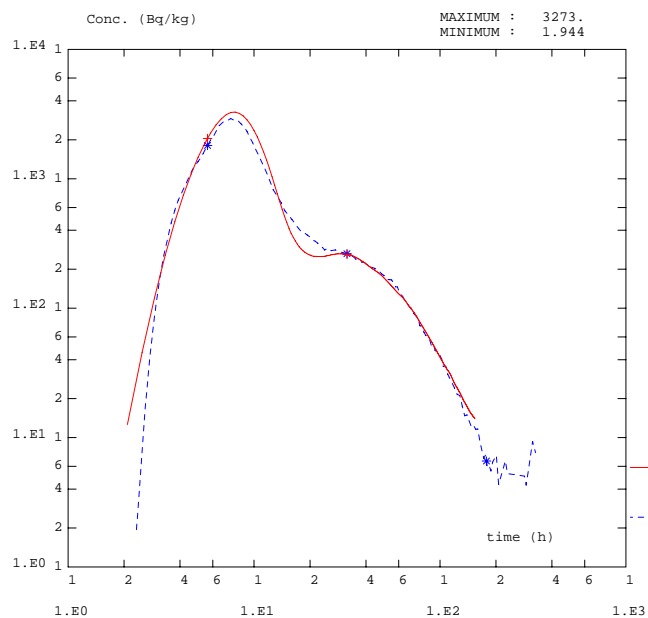
▷ Iodine case : 1D Conv/Disp vs. Conv./Disp/Matr.Diff



DM2S/SFME/MTMS



# Sensitivity to matrix diffusion, iodine



Veloc. (m/s)	Disp. (m)	Matr. Diff. (m/s) $D_e$
$2.1 \cdot 10^{-4}$	0.3	$10^{-13} - 10^{-12}$



## PA to SC : Model improvements required ? Black box type vs. Phys. Geol. based

- *Radial flow*

- ▷ Flow reduced to a flow tube
- ▷ Radial flow patterns
- ▷ Reduce to PA model

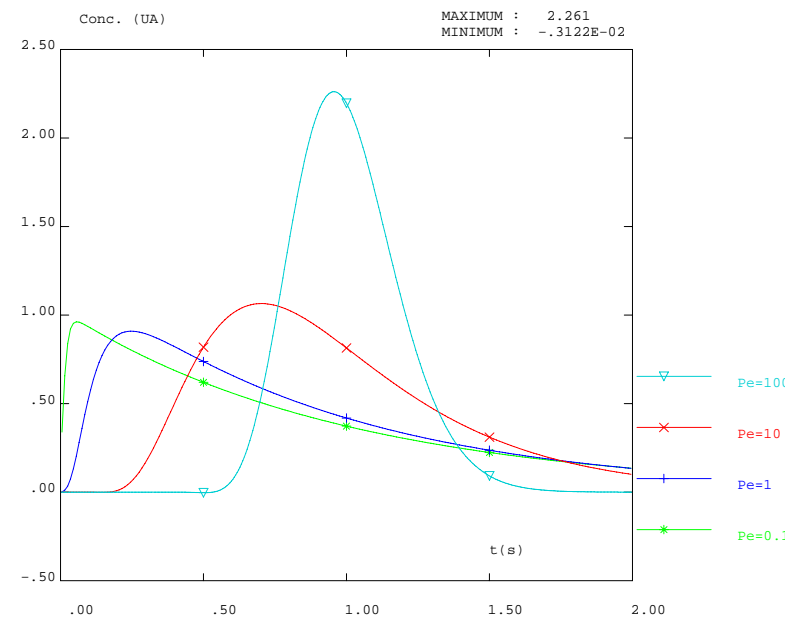
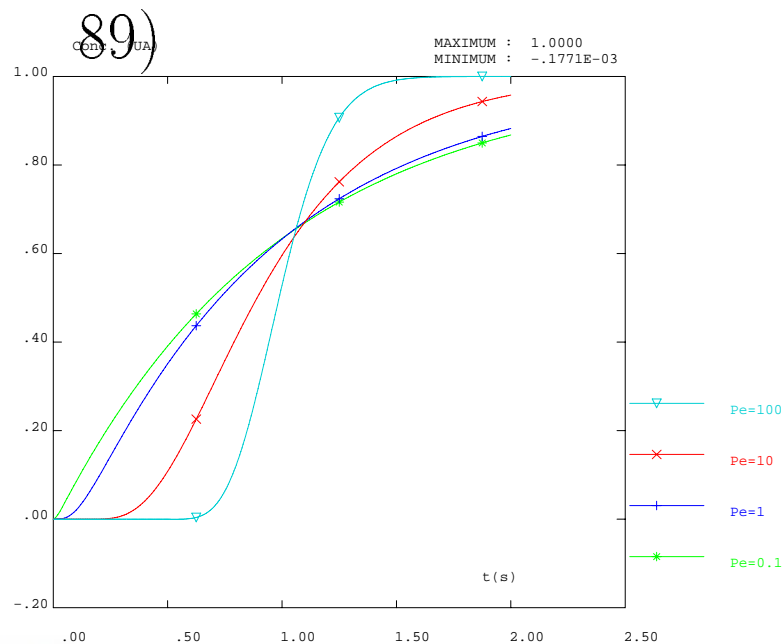
- *Heterogeneity*

- ▷ Consider heterogeneity of no flow zone characteristics
- ▷ Reduce to PA model



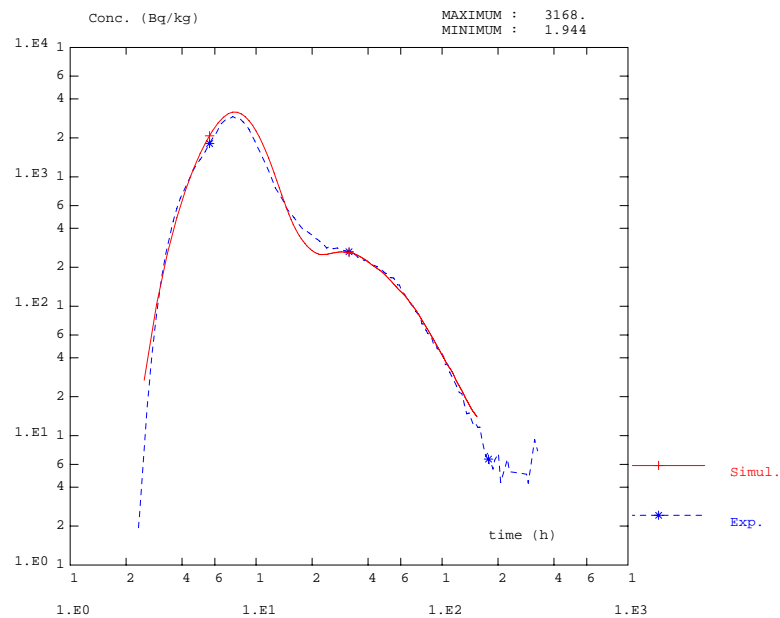
# Present stand for radial flow models

- *Choose a meaningful dispersivity structure*
- *Test numerical simulation tools*
  - ▷ Difficulty : velocity = fct(radius)
  - ▷ Numerical approach : Eulerian / Lagrangian (Moench



# Radial flow and transport model (no matrix diffusion yet)

- *Fits the general shape*
- *Easy to improve in a next step including matrix diffusion*

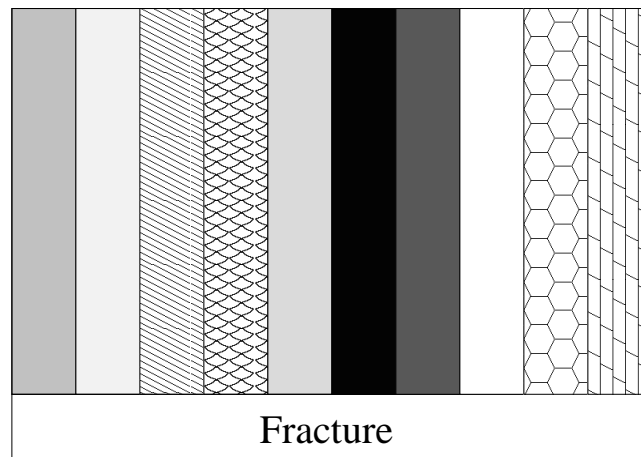


DM2S/SFME/MTMS



# Heterogeneity

- *Heterogeneity for no flow zones characteristics*
- *Search for equivalent diffusion in PA model*



Heterogeneous  
Matrix zones

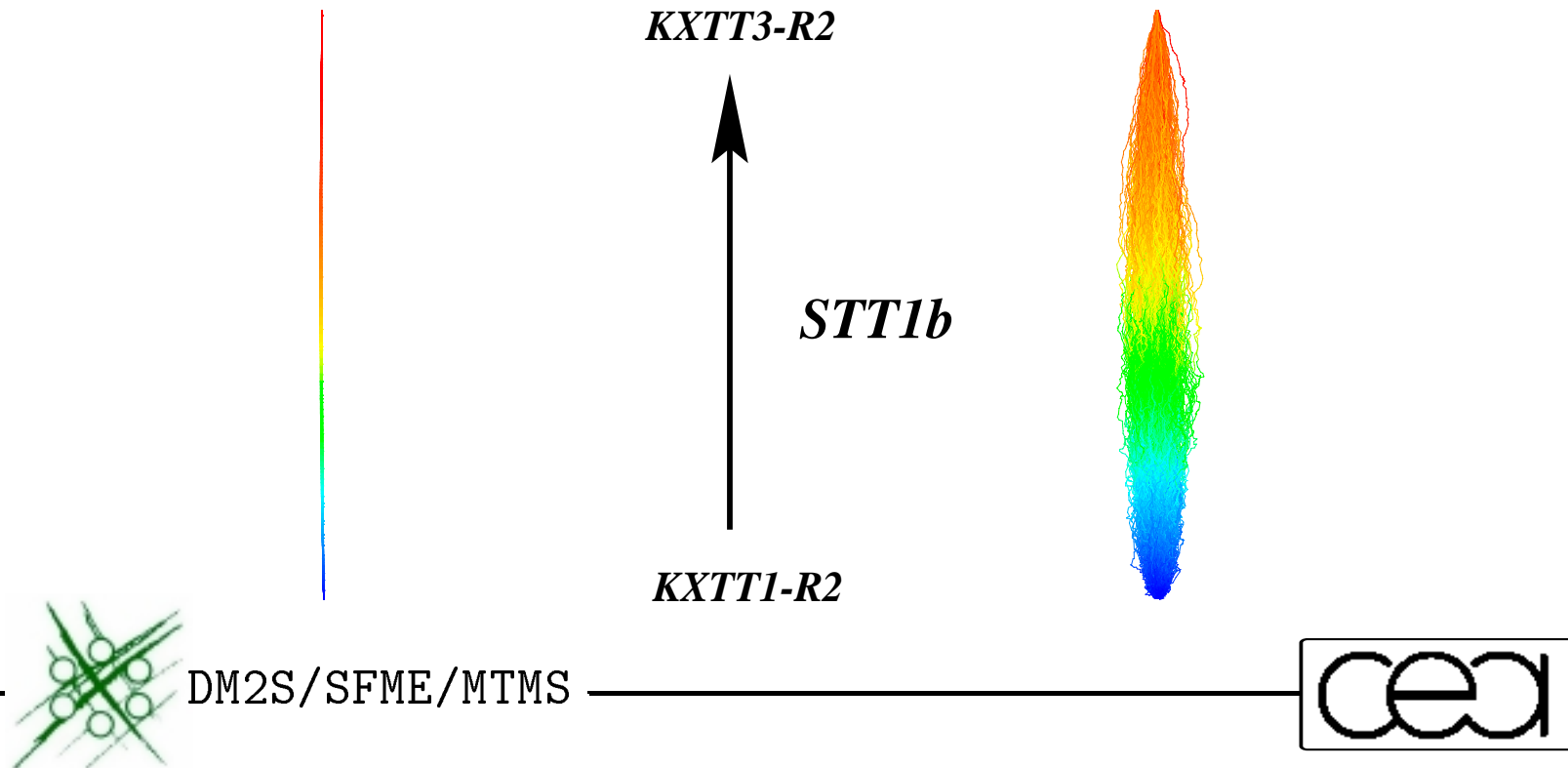


DM2S/SFME/MTMS



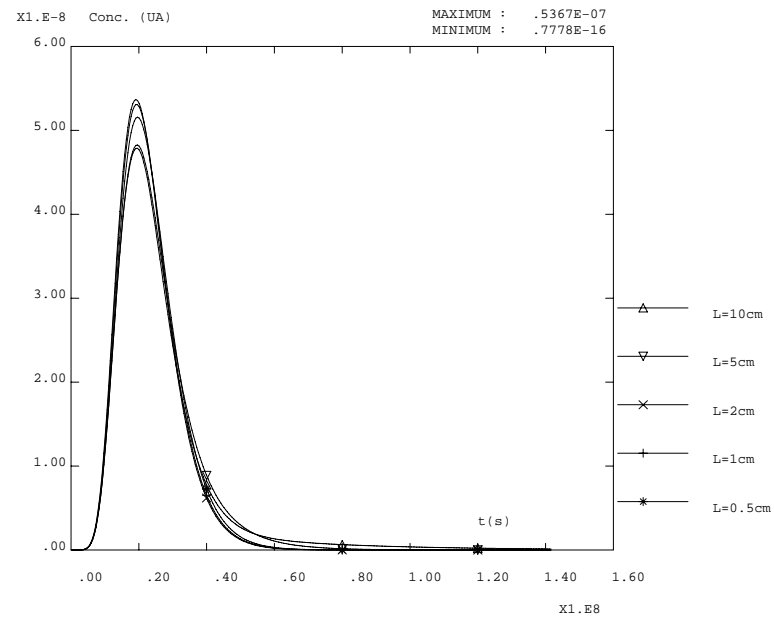
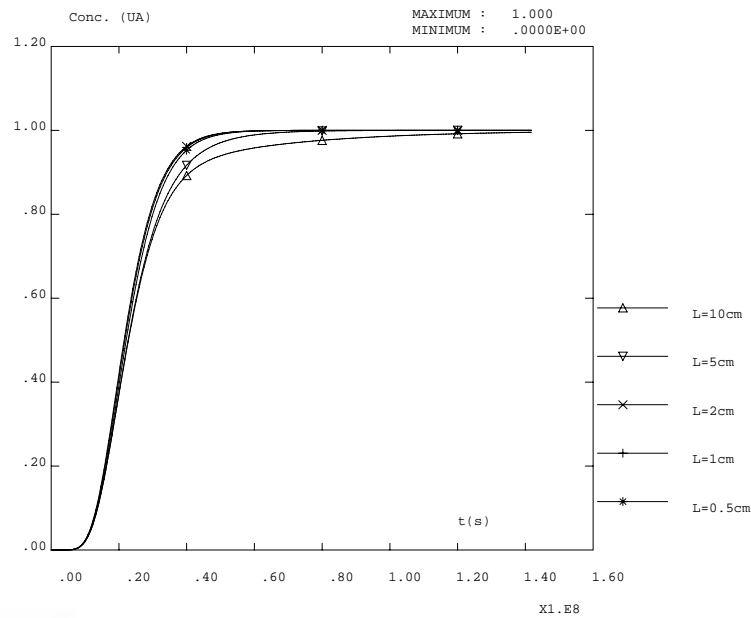
## Task6B vs. Task6A

- *Flow velocity reduced by 1000*
- *Plume explores a broader zone due to diffusion time*
  - ▷ In the fracture plane and in the depth of no flow zones



# Prediction for the 1D model in Task6B conditions

o *Sensitivity to penetration depth*

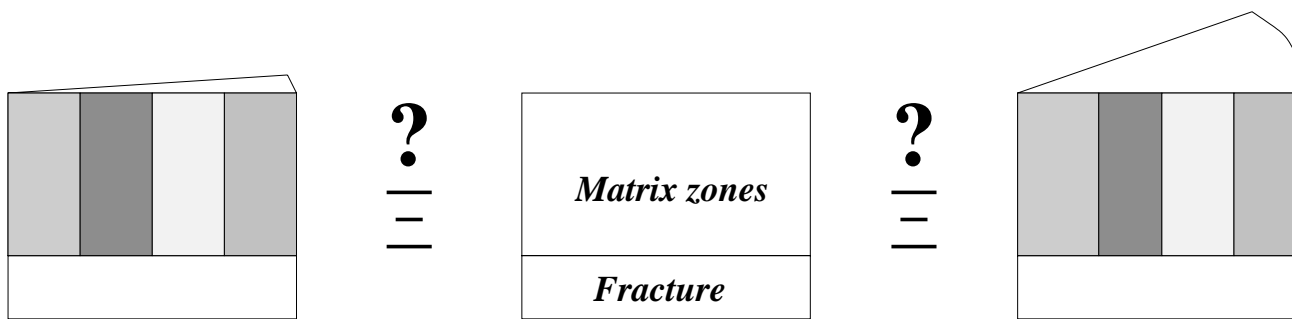


DM2S/SFME/MTMS



# Orientations for Task6B

- Use a 2D fracture model with matrix diffusion
- Sensitivity analysis to penetration depth
- Radial flow and heterogeneity
- Reduce to the 'equivalent' 1D PA model ?



*Task6A*

*1D reference model*

*Task6B*



DM2S/SFME/MTMS



## Appendix U

[Proposal for Construction of a Semi-Synthetic  
conceptual hydrostructural model  
A Winberg \(Conterra\)](#)



# **Proposal for construction of a semi-synthetic conceptual hydrostructural model**

**Anders Winberg, Conterra AB  
Jan Hermanson, Golder Associates AB**

*15th Äspö Task Force Meeting  
Goslar, Germany, Sep 11-13, 2001*

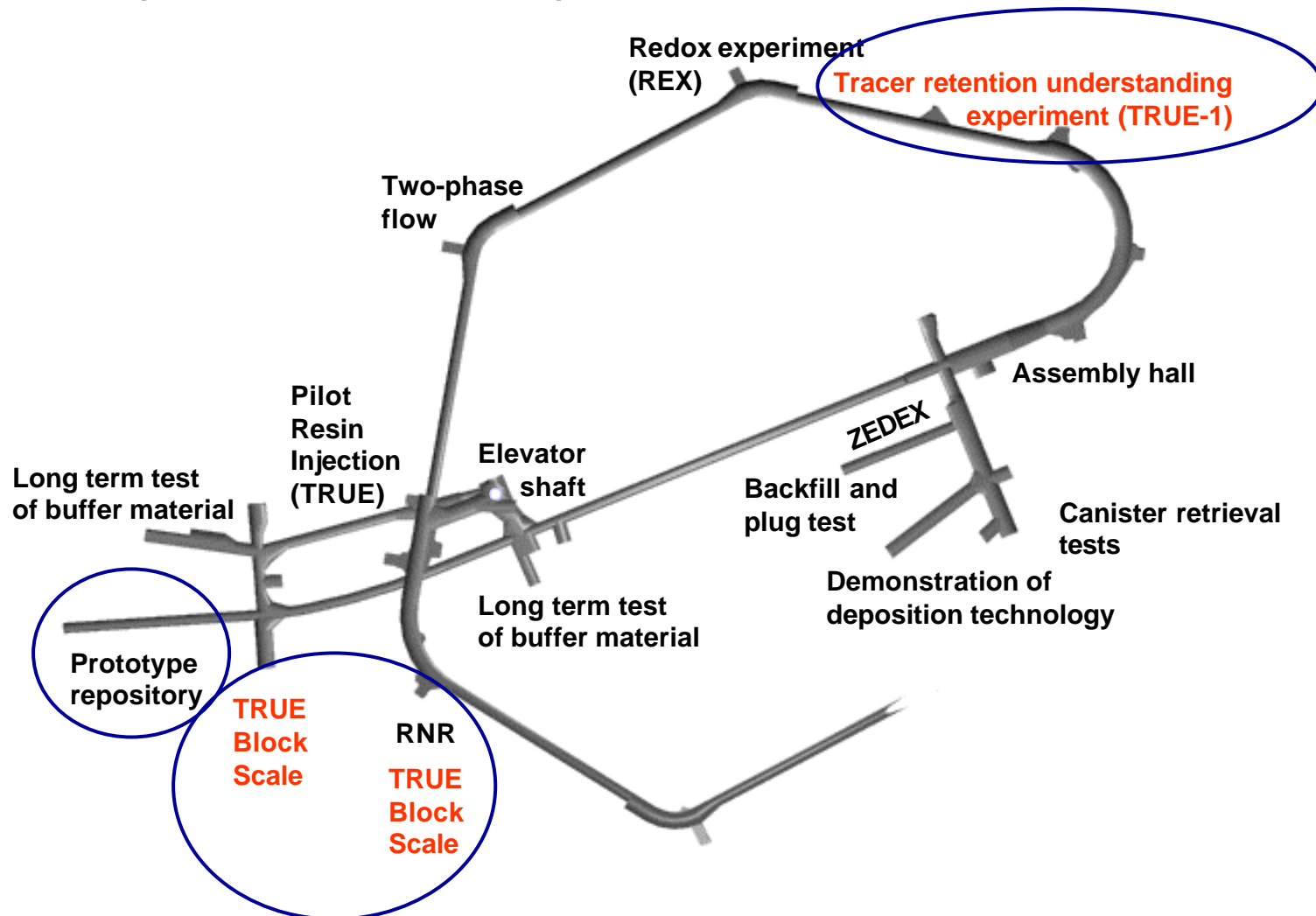


# **Task 6C**

## **Paraphrased objectives**

- **Develop a 50-100m block scale synthesised structural model,**
- **Use data from the Prototype Repository, TRUE Block Scale, TRUE-1 and FCC,**
- **Complement structural model with a hydraulic parameterisation using existing databases,**
- **Deterministic rather than a stochastic model is constructed,**
- **Compare results of variations in assumptions, simplifications, and implementations,**
- **Include sufficient elements of the TRUE Block Scale to enable reproduction of TRUE Block Scale tracer experiments as part of Task 6D,**
- **Task 6C to be performed by a single group led by SKB.**

# Location of experimental sites for TRUE-1, Prototype repository and TRUE Block Scale



# Task 6C

## Interpretation of objectives

- **Couple and relate descriptive model scales such that model calculations based on the linked model/-s become realistic,**
- **“Realistic” in a sense that model output in terms of simulated transport from a given canister position, through a detailed scale fracture of TRUE-1 type, coupled to a network of fractures and structures of TRUE Block Scale or Prototype type “is in accord with what is to be expected”,**
- **An important premise is that the planned numerical models should exclude the spiral access tunnels since the subsequent model calculations should reflect transport through virgin bedrock under performance assessment type hydraulic boundary conditions.**

# Task 6C

## Scales considered

Scale	L (m)	Data source : Project/model
Detailed scale	$L < 5$	TRUE-1, LTDE, (Prototype), FCC-III
Block Scale	$10 < L < 100$	TRUE Block Scale Prototype FCC-II (TRUE-1)
Site scale	$100 < L < 1000$	Äspö site conceptual model FCC-II

# Task 6C

## Detailed scale - Models related to TRUE-1

### Hydrostructural and conceptual models

- TRUE-1 descriptive and conceptual models :
  - Winberg et al. (2000)
  - Mazurek and Jacob (2001)
  - Neretnieks and Moreno (in prep.)
  - Bossart et al. (2001) (FCC-3)
  - ....

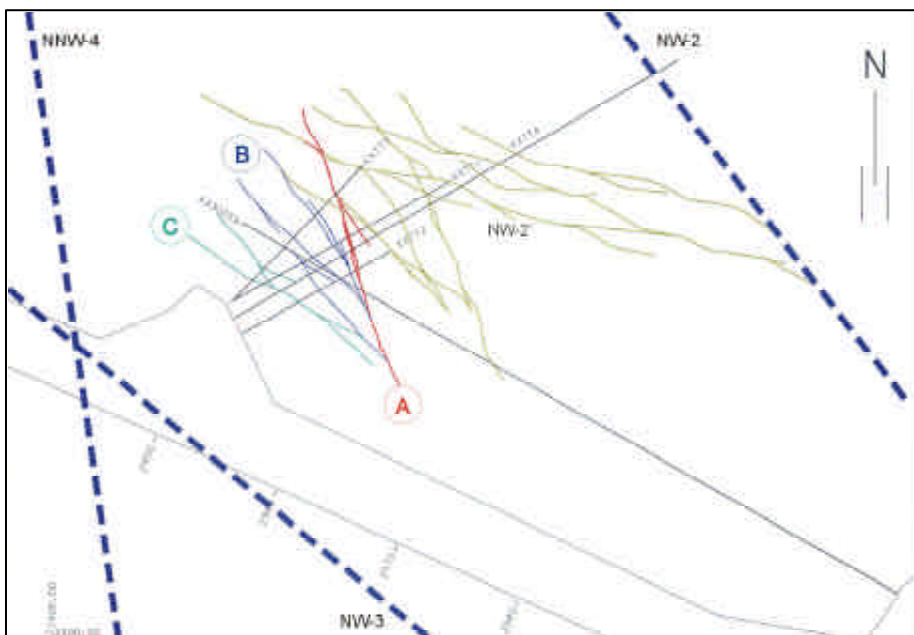
### Numerical flow and transport models

- TRUE-1 flow and transport models :
  - Task 4C/D reports ICR
  - Task 4E/F reports ICR
  - Overview of results
    - Elert 1999 Task 4C/D
    - Elert and Svensson, 2001)
  - Proc. of 4th Int. Äspö Seminar (in press) SKB TR
  - ...

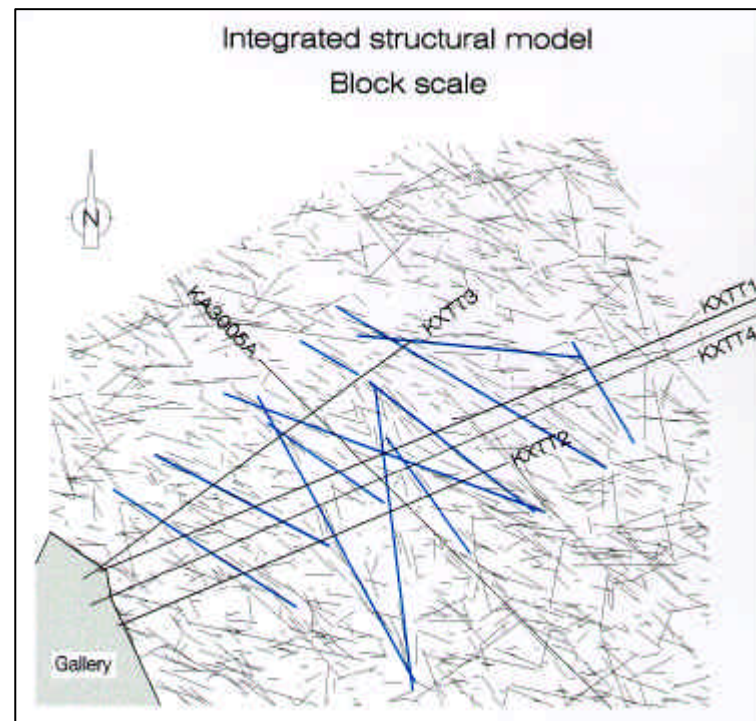


# Detailed scale - TRUE-1

## Examples of hydrostructural models



Winberg et al., (2000)



Bossart et al. (2001)

# Task 6C

## Available models related to Prototype

### Hydrostructural and conceptual models

- Descriptive structural-geological model :
  - Patel and Dahlström (in prep)
- Descriptive hydraulic model :
  - Rhén and Forsmark (in prep)
- Integration of models planned

### Numerical flow and transport models

- Flow and transport models :
  - Svensson (2001) (**SC**)  
*Size: 166x96x73 m*
  - Stigsson et al., (in press) (**DFN**)  
*Size : 100x175x100 m*
  - Outters and Hermanson (in prep) (**DFN**)  
*Size : 100x100x100 m*

BCs collected from SC "Laboratory model".



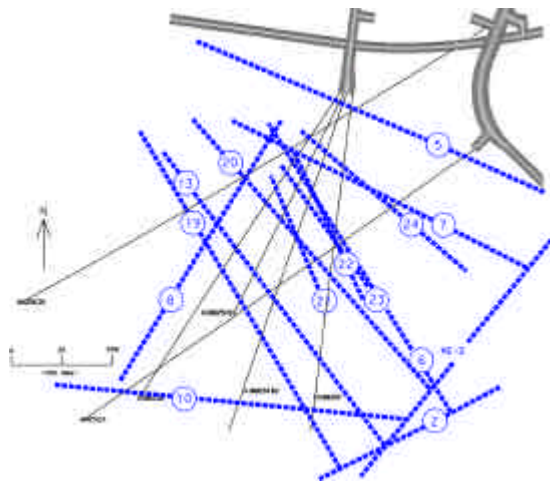


## Task 6C

# Available models related to TRUE Block Scale

### Hydrostructural and conceptual models

- Hydrostructural model :
  - Hermanson and Doe (2000)
  - Andersson et al. (in prep)
  - Supporting work (IPR series)



### Numerical flow and transport models

- Flow and transport models :
  - Gomez-Hernandez et al. (in prep) (**SC**)
  - Holton et al. (in prep) (**DFN**)
  - Dershowitz et al. (in prep) (**CN/PA Works**)
  - Cvetkovic and Cheng (in prep) (LaSAR)
  - Poteri and Hautojärvi (in prep) (POSIVA approach)
  - Reports on supporting work (IPR series)

# Task 6C

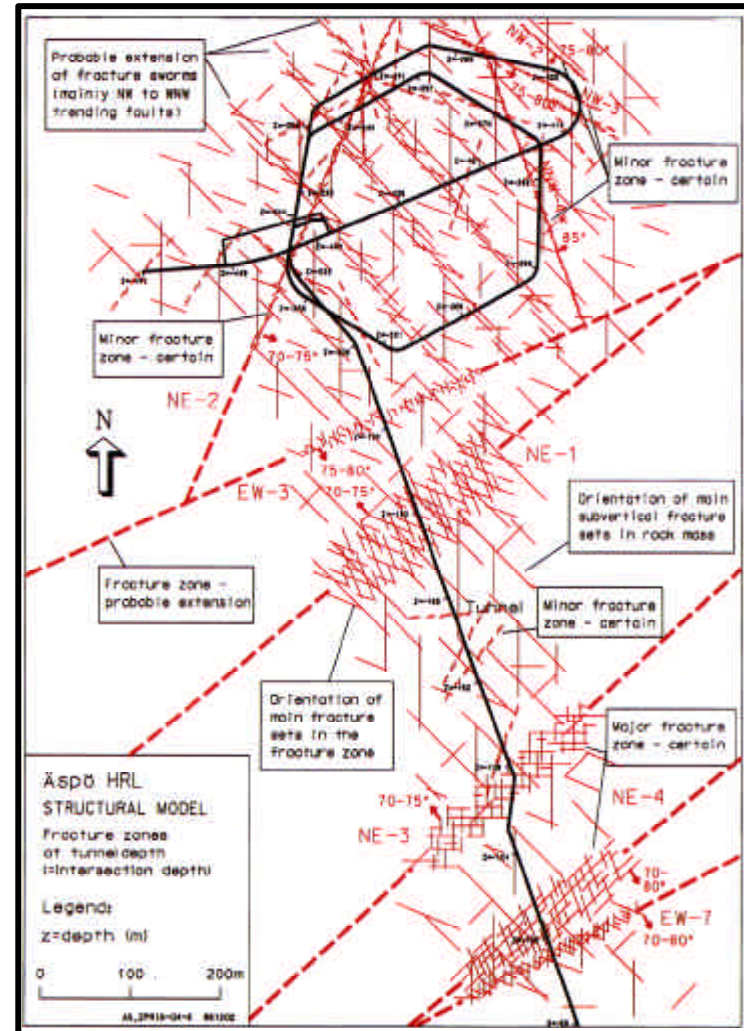
## Models produced by FCC project

- **FCC II (features in access tunnel) (Mazurek et al., 1997)**
  - *Detailed geometrical and structural descriptions of a number of structures along the access tunnel and also on the land surface. Scales considered span the full range from microscopic to site-scale. Supporting data include mineralogical analyses and epoxy resin injections.*
- **FCC III (TRUE-1) (Bossart et al., 2001)**
  - *Alternative interpretation of TRUE-1 site presented where the studied TRUE-1 rock block is made up of a dense fracture network featured by a superimposed lattice of structures made up of mylonitic fracture components.*

# Task 6C

## Site scale models

- **Hydrostructural and conceptual models**
  - Munier and Hermanson (1994)
  - Rhén et al. (1997) →
  - Mazurek et al. (1997)
  - .....



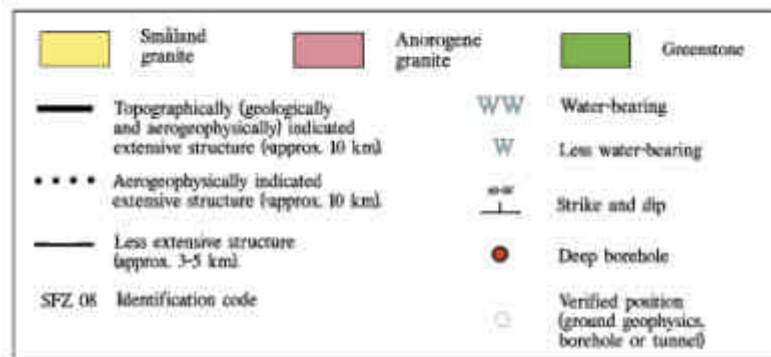
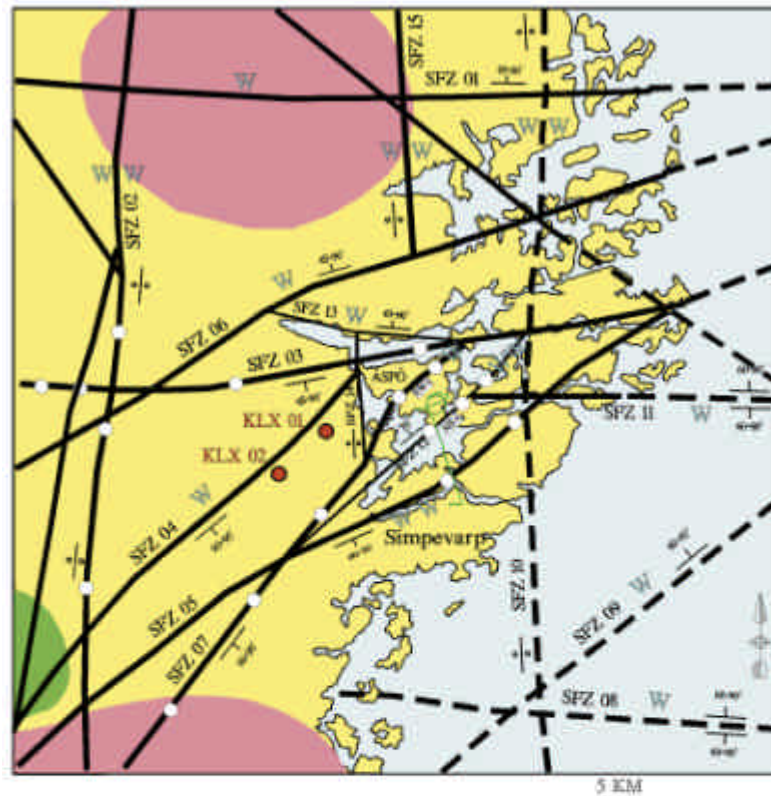
# Task 6C

## Site scale flow and transport models

- **Widén and Walker (1999) (SC) (SR-97)**
- **Painter (1999) (SC)**
- **Dershowitz et al. (1999) (DFN) (SR-97)**
- **Outters and Shuttle (2000) (DFN)**
- **Gylling et al. (1999) (CN) (SR-97)**
- **Svensson (1997) (SC) "Site model"**
- **Svensson (1999) (SC) "Laboratory model"**
- **Contributions to Tasks 1, 3 and 5 (Äspö Task Force)**

# Task 6

## Regional scale



# Task 6C

## Premises/constraints for construction of ”structural model”

- **Ultimate goal of the subsequent modelling tasks (6D/6E)**
- **Available descriptive geological/hydraulic and hydrostructural models**
- **Available numerical models at various scales**
- **Available time and resources.**

**Two possible routes investigated**

# Task 6C

## "Geological model approach"

- **Available descriptive hydrostructural models at defined scales are used to build an integrated synthesised hydrostructural model of Äspö,**
- **Whole range of possible scales covered,**
- **Assignment of material properties is made on the basis of existing data bases.**

### Pros :

- Intuitively appealing.
- Capitalises and integrates geometrical and parametric data from a wide spectrum of projects, scales and geological environments.
- Existing mechanistic understanding and interpretation possible to build in.

### Cons :

- Numerical flow and transport models may have to be partially built from scratch.
- Level of detail in the corresponding flow and transport models decisive.
- Potentially time and resource consuming!



# Task 6C

## "Numerical model approach"

- **Use existing linked or nested models which integrates models of multiple scales,**
- **Semi-synthetic aspects are brought in by:**
  - **adding/deleting existing structures/fracture zones**
  - **changing geometry of structures**
  - **changing the properties of the structures and the rock blocks between structures****.. in the existing numerical models.**

### Pros :

- Easy start up of work possible,
- Possibility to use existing calibrated flow and transport models,
- Scale transitions enabled by nested or coupled models.

### Cons :

- Use of existing numerical models implies that the underlying hydrostructural model is retained,
- Difficult to import features from a new semi-synthetic hydrostructural model?!,
- Existing old conceptual errors may be locked in,
- Time consuming to correct unwanted features,
- Large effort for new parties.





# Task 6

## Assessment of available models and data

- The TRUE Block Scale rock volume offers:
  - a relatively robust hydrostructural model of connected deterministic structures
  - associated numerical flow and transport models
  - corresponding comprehensive database
- Data also fulfil most of the pros, and suppresses most of the cons presented
- Database of cross-hole hydraulic interference, tracer dilution and tracer tests for calibration purposes.
- But ...planned forward simulations are to be made using a model which does not include the underground openings.

**Balanced “Geological approach” most appealing!**



## **Task 6C**

### **Proposed outline of detailed approach**

- **Use the TRUE BS structural model to distribute/reproduce the model principally in a larger area delineated by fracture zones EW-1 and EW-3/NE-1,**
- **Done in a statistical sense with the ambition to retain a systematic structural pattern in a series of co-adjacent subareas, and without violating the underlying structural mechanistic model, and available site models,**
- **TRUE-1 Feature A or FCC type structures can be introduced/superimposed/draped on existing structures,**
- **The rock mass between deterministic structures can be assigned background fracture/equivalent continuum properties,**
- **Boundary conditions, or alternatively nesting of models, can be achieved through the use of existing site scale numerical models.**

## Appendix V

Views on Task 6,  
M. Mazurek (University of Bern)

## **Lessons learnt from the TRUE-1 blind predictions (STT1)**

- Justification for the choice of a specific computational model is often missing
- Lacking correlation between model complexity and goodness of prediction (or maybe even an inverse correlation ?)
  - How to parametrize very complex models ?
- Need to specify what is important:
  - Detailed flow-field description is not relevant (the flow field is very simple)
  - A detailed deterministic structural characterization would be useful but is not feasible
  - Wallrock characteristics in the immediate surroundings of the flow porosity are highly important
- Revisit strategy of investigation
  - Process identification
  - Scoping calculations

## **Logic line of argument - or: How to put the problem (blind predictions) into a scientific framework**

- a. Compilation and synthesis of experimental site information
- b. Conceptualization of the test volume
- c. Scoping calculations and process identification
- d. Choice of appropriate computational tools
  - which include all relevant processes
  - where the model complexity is in proportion with the availability of site data needed for parametrization
- e. Model predictions and sensitivity analysis

## Resulting input to Task 6

- Different scales in time and space to be treated very differently - any need for a "hydro-structural model" as the one presented for TRUE Block scale ?
- Long-term retardation occurs in very different rock domains when compared to short-time retardation
  - Fracture infills
  - Altered / fresh mylonite
  - Altered granite
  - Fresh granite
- Highlight current opinion about the accessibility of the fresh granitic matrix for matrix diffusion
- Potential learning effects of the Task 6 model calculations
  - Size of the capture zone in different types of model setups and scales
  - Where does retardation occur at what time ?
  - Which part of the system dominates retardation (key question in geosphere transport)
- Fix existing imbalance in the depth of investigations, e.g. very detailed "hydrostructural model" vs major gaps in the understanding of retardation properties of relevant rock types ( $K_d$ , porosity)