

**International
Progress Report**

IPR-09-09

Äspö Hard Rock Laboratory

Prototype Repository

**Sensors data report
(Period 010917-081201)
Report No: 20**

Compiled by

Reza Goudarzi

Lars-Erik Johannesson

Clay Technology AB

March 2009

Svensk Kärnbränslehantering AB

Swedish Nuclear Fuel
and Waste Management Co

Box 250, SE-101 24 Stockholm
Phone +46 8 459 84 00



**Äspö Hard Rock
Laboratory**

Report no.	No.
IPR-09-09	F63K
Author	Date
Reza Goudarzi	March 2009
Lars-Erik Johannesson	
Checked by	Date
Lars-Erik Johannesson	2009-05-05
Approved	Date
Anders Sjöland	2009-05-14

Äspö Hard Rock Laboratory

Prototype Repository

Sensors data report (Period 010917-081201) Report No: 20

Compiled by

Reza Goudarzi
Lars-Erik Johannesson

Clay Technology AB

March 2009

Keywords: Fields test, Data, Prototype, Bentonite, Rock, Canister measurements, Water, Pressure, Total pressure, Relative humidity, Temperature, Displacements, Geoelectric

This report concerns a study which was conducted for SKB. The conclusions and viewpoints presented in the report are those of the author(s) and do not necessarily coincide with those of the client.

Abstract

The Prototype Repository Test consists of two sections. The installation of the first Section of Prototype Repository was made during summer and autumn 2001 and Section 2 was installed in spring and summer 2003.

This report presents data from measurements in the Prototype Repository during the period 010917-081201. The report is organized so that the actual measured results are shown in Appendix 1-10, where Appendix 8 deals with measurements of canister displacements (by AITEMIN), Appendix 9 deals with geo-electric measurements in the backfill (by GRS), Appendix 10 deals with stress and strain measurement in the rock (by BBK) and Appendix 11 deals with measurement of water pressure in the rock (by VBB/VIAK). The main report and Appendix 1-7 deal with the rest of the measurements.

Section 1

The following measurements are made in the bentonite in each of the two instrumented deposition holes in Section 1 (1 and 3): Temperature is measured in 32 points, total pressure in 27 points, pore water pressure in 14 points and relative humidity in 37 points. Temperature is also measured by all relative humidity gauges. Every measuring point is related to a local coordinate system in the deposition hole.

The following measurements are made in the backfill in Section 1. Temperature is measured in 20 points, total pressure in 18 points, pore water pressure in 23 points and relative humidity in 45 points. Temperature is also measured by all relative humidity gauges. Furthermore, water content is measured by an electric chain in one section. Every measuring point is related to a local coordinate system in the tunnel.

The following measurements are made on the surface of the canisters in Section 1: Temperature is measured every meter along two fiber optic cables. Furthermore, displacements of the canister in hole 3 are measured with 6 gauges.

The following measurements are made in the rock in Section 1: Temperature is measured in 37 points in boreholes in the floor. Water pressure is measured in altogether 64 points in 17 boreholes all around the tunnel.

Section 2

The following measurements are made in the bentonite in each of the two instrumented deposition holes in Section 2 (5 and 6): Temperature is measured in 29 points, total pressure in 27 points, pore water pressure in 14 points and relative humidity in 47 points deposition hole 5 and in 65 points in deposition hole 6. Temperature is also measured by all relative humidity gauges.

The following measurements are made in the backfill in Section 2. Temperature is measured in 16 points, total pressure in 16 points, pore water pressure in 18 points and relative humidity in 32 points. Temperature is also measured by all relative humidity gauges. Furthermore, water content is measured by an electric chain in one section. Every measuring point is related to a local coordinate system in the tunnel.

The following measurements are made on the surface of the canisters in Section 2: Temperature is measured every meter along two fiber optic cables. Additional to this temperature measurement three conventional thermocouples are placed on each canister. Furthermore, displacements of the canister in hole 6 are measured with 6 gauges.

The following measurements are made in the rock in Section 2: Temperature is measured in 24 points in boreholes close to the deposition holes. Relative humidity is also measured in 6 points in the rock close to deposition hole 6.

Conclusions

A general conclusion is that the measuring systems work well, but the number of sensors that has failed is increasing. 246 (excluding water pressure sensors in the rock, geo-electric measurements) out of totally 363 installed sensors in Section 1 are out of order, the majority being RH-sensors that fail at water saturation. 135 (excluding water pressure sensors in the rock, geo-electric measurements, stress and strain in the rock and displacement of canister) out of totally 394 sensors in Section 2 are out of order. Furthermore almost all suction sensors placed in the backfill is not giving reliable values due to high degree of saturation (RH 100%)..

The drainages of the inner section together with the drainage of the outer plug were closed at the beginning of November 2004. The pressure (pore pressure and total pressure) both in the backfill and in some parts of the buffer in the six deposition holes increased after this date. At the beginning of December 2004 damages was observed on two of the canisters (canister No 2 and No 6). The power to all of the canisters was then switched off and the drainage of the tunnel was opened. The power of canisters was switched on again on December 15 except for canister No 2 which was out of order. The drainage of the tunnel was kept open. The increase in pore pressure affected the saturation rate of the backfill and the buffer. The failure of canister No 2 and the time when the power was switched off affected also the measurements especially the temperature measurements in the buffer. At the beginning of September 2005 more problems with the power to canister 6 was observed. The power to the canister was switched off for about 2 months. The power to canister 6 was switched on again on November 2 2005. Due to new problems with the heaters in canister No 6 in May and June 2008 the power was reduced to about 1150 W. A packer installed in the rock in Section 1 was broken around the 18th of April 2006. The broken packer caused an increase in the measured total and pore pressure in the backfill in Section 1. The work with the new tunnel near by the Prototype site which started in April 2007 has affected the pressure, water outflow and saturation of the backfill.

Sammanfattning

Prototypförvaret består av två sektioner. Den första sektionen installerades under sommaren och hösten 2001 och Sektion 2 installerades under våren och sommaren 2003.

I denna rapport presenteras data från mätningar i Prototypförvaret för perioden 010917-081201. Rapporten är uppdelad så att själva mätresultaten redovisas i Appendix 1-10, varvid Appendix 8 behandlar mätning av kapselförskjutningar (görs av AITEMIN), Appendix 9 behandlar geoelektriska mätningar i återfyllningen (görs av GRS), Appendix 10 behandlar mätningar av spänning och töjning i berget (handhas av BBK) och Appendix 11 behandlar vattentrycksmätningar i berget (handhas av VBB/VIAK). I själva huvudrapporten och Appendix 1-7 behandlas alla övriga mätningar.

Sektion 1

Följande mätningar görs i bentoniten i vardera av de två instrumenterade deponeringshålen i Sektion 1 (1 och 3): Temperatur mäts i 32 punkter, totaltryck i 27 punkter, porvattentryck i 14 punkter och relativa fuktigheten i 37 punkter. Temperaturen mäts även med relativa fuktighetsmätare. Varje mätpunkt relateras till ett lokalt koordinatsystem i deponeringshålet.

Följande mätningar görs i återfyllningen i Sektion 1: Temperaturen mäts i 20 punkter, totaltryck i 18 punkter, porvattentryck i 23 punkter och relativa fuktigheten i 45 punkter. Temperaturen mäts även med alla relativa fuktighetsmätare. Varje mätpunkt relateras till ett lokalt koordinatsystem i tunneln. Dessutom mäts vatteninnehållet i en sektion med en geoelektrisk mätkedja.

Följande mätningar görs på ytan i kapselns kopparhölje i samtliga 4 kapslar i Sektion 1: Temperaturen mäts varje meter längs två fiberoptiska kablar från två håll. Dessutom mäts förskjutningar av kapseln i hål 3 med 6 givare.

Följande mätningar görs i berget i Sektion 1: Temperatur mäts i borrhål i 37 punkter i golvet. Vattentryck mäts i sammanlagt 64 punkter i 17 borrhål runt hela tunneln.

Sektion 2

Följande mätningar görs i bentoniten i vardera av de två instrumenterade deponeringshålen i Sektion 2 (5 och 6): Temperatur mäts i 29 punkter, totaltryck i 27 punkter, porvattentryck i 14 punkter och relativa fuktigheten i 47 punkter i deponeringshål 5 och 65 punkter i deponeringshål 6. Temperaturen mäts även i alla relativa fuktighetsmätare.

Följande mätningar görs i återfyllningen i Sektion 2: Temperaturen mäts i 16 punkter, totaltryck i 16 punkter, porvattentryck i 18 punkter och relativa fuktigheten i 32 punkter. Temperaturen mäts även med alla relativa fuktighetsmätare. Varje mätpunkt relateras till ett lokalt koordinatsystem i tunneln. Dessutom mäts vatteninnehållet i en sektion med en geoelektrisk mätkedja.

Följande mätningar görs på ytan i kapselns kopparhölje i de två kapslarna i Sektion 2: Temperaturen mäts varje meter längs två fiberoptiska kablar från två håll. Vidare mäts temperaturen i tre punkter på varje kapsel med konventionella termoelement. Även förskjutningen av kapseln i deponeringshål 6 mäts med 6 givare.

Temperatur mäts i berget kring varje kapsel i 24 punkter. Vidare mäts RH i berget kring deponeringshål 6 i 6 punkter.

Slutsatser

En generell slutsats är att mätsystemen tycks fungera bra. 246 av totalt 363 installerade givare i Sektion 1 (med undantag av vattentrycksmätare i berget) fungerar inte. Många av dessa (64 stycken) är RH-mätare som slutar fungera vid vattenmättnad. 135 av 394 givare i Sektion 2 (med undantag av vattentrycksmätare i berget) fungerar inte. Dessutom har en del psychrometrar (21) placerade i återfyllningen slutat att ge relevanta värden på grund av att fyllningen närmar sig vattenmättnad.

Dräneringen av den inre sektionen och den yttre pluggen stängdes i början av november 2004. Portrycket och totaltrycket både i återfyllnaden och i bufferten ökade markant efter stängningen av dränaget. Ökningen av portrycket påverkade också vattenmättnaden i vissa delar av buffert och återfyllnade. Skador observerades på två av kapslarna i början av december 2004, varefter effekten till samtliga kapslar stängdes av samtidigt som dräneringen av tunneln öppnades. Effekten till alla kapslar utom kapsel nr. 2 sattes på igen den 15:e december. Skadorna på kapsel 2 var så omfattande att det inte var möjligt att koppla in någon effekt på denna. Dräneringen av tunneln förblev öppen. I början av september 2005 uppstod nya problem med kapsel Nr 6. Effekten till kapseln stängdes av under ca 2 månader. Från och med den 2:a november 2005 sattes effekten till kapsel Nr 6 på igen. På grund av nya problem med värmarna i kapsel 6 under maj och juni 2008 reducerades effekten till 1150 W. En packer installerad i berget i Sektion 1 gick sönder kring den 18:e april 2006. Den läckande packern medförde att totaltrycken och portrycken i återfyllningen i Sektion 1 ökade markant. Arbetet med den nya tunneln nära Prototype-tunneln vilket startade i april 2007 har påverkat tryckte, utflödet ur tunneln samt vattenmättnaden av återfyllningen i de båda tunnelsektionerna.

Contents

1	Introduction	11
2	Geometry and coordinate systems	13
3	Brief description of the instruments	15
	Measurements of temperature	15
	Measurement of total pressure in the buffer and backfill	15
	Measurement of pore water pressure in the buffer and backfill	15
	Measurement of the water saturation process in the buffer and backfill	15
4	Location of instruments in Section 1	17
4.1	Strategy for describing the position of each device in the bentonite and rock in and around the deposition holes	17
4.2	Position of each instrument in the bentonite in hole 1 (DA3587G01)	19
4.3	Position of each instrument in the bentonite in hole 3 (DA3575G01)	23
4.4	Instruments on the canister surface in holes 1-4	27
4.5	Position of temperature sensors in the rock	29
4.6	Strategy for describing the position of each device in the backfill in section 1	31
4.7	Position of each instrument in the backfill	33
5	Results and comments for Section 1	37
5.1	General	37
5.2	Deposition hole 1	39
	5.2.1 Total pressure	39
	Geokon (App. 1\pages 93-95)	39
	Kulite (App. 1\page 96)	39
	5.2.2 Relative humidity	39
	Vaisala (App. 1\pages 97-100)	39
	Rotronic (App. 1\pages 101-105)	40
	5.2.3 Pore water pressure	40
	Geokon (App. 1\page 106)	40
	Kulite (App. 1\page 107)	40
	5.2.4 Temperature in the buffer (App. 1\pages 108-114)	40
	5.2.5 Canister power in dep. hole 1 (App. 1\page 118)	41
	5.2.6 Temperature on the canister surface (App. 1\pages 119-120)	41
5.3	Deposition hole 3	41
	5.3.1 Total pressure	41
	Geokon (App. 2\pages 123-125)	41
	Kulite (App. 2\pages 126-127)	42
	5.3.2 Relative humidity	42
	Vaisala (App. 2\pages 128-131)	42
	Rotronic (App. 2\pages 132-136)	42
	5.3.3 Pore water pressure.	42
	Geokon (App. 2\page 137)	42
	Kulite (App. 2\page 138)	42
	5.3.4 Temperature in the buffer (App. 2\pages 139-145 and 148)	43
	5.3.5 Canister power (App. 2\page 149)	43
	5.3.6 Temperature on the canister surface (App. 2\pages 150-151)	43

5.4	Deposition hole 2	43
5.4.1	Canister power (App. 3\page 156)	43
5.4.2	Temperature on the canister surface (App. 3\pages 157-159)	44
5.5	Deposition hole 4	44
5.5.1	Canister power (App. 3\page 161)	44
5.5.2	Temperature on the canister surface (App. 3\pages 162-163)	44
5.6	Backfill in Section 1	44
5.6.1	Total pressure in the backfill	44
	Geokon (App. 4\pages 167-168)	44
	Kulite (App. 4 \pages 169-170)	45
5.6.2	Suction in the backfill (App. 4\pages 171-177)	45
5.6.3	Pore water pressure in the backfill	45
	Geokon (App. 4\pages 178-179)	45
	Kulite (App. 4\pages 180-181)	45
5.6.4	Temperature in the backfill (App. 4\pages 182-186)	46
5.7	Temperature in the rock	46
5.7.1	Near hole 1 (App. 1\pages 115-117)	46
5.7.2	Near hole 2 (App. 3\page 155)	46
5.7.3	Near hole 3 (App. 2\pages 146-147)	46
5.7.4	Near hole 4 (App. 3\page 160)	46
5.8	Analyze of data from Section 1	47
5.8.1	Deposition hole 1.	47
5.8.2	Deposition hole 3.	49
5.8.3	Backfill.	52
6	Location of instruments in Section 2	53
6.1	Strategy for describing the position of each device in the bentonite and rock in and around the deposition holes	53
6.2	Position of each instrument in the bentonite in hole 5 (DA3551G01)	54
6.3	Position of each instrument in the bentonite in hole 6 (DA3545G01)	59
6.4	Instruments on the canister surface in holes 5-6	64
6.5	Position of temperature sensors in the rock	64
6.6	Strategy for describing the position of each device in the backfill in section 2	66
6.7	Position of each instrument in the backfill in Section 2	66
7	Results and comments for Section 2	71
7.1	General	71
7.2	Deposition hole 5	73
7.2.1	Total pressure	73
	Geokon (App. 5\pages 189-192)	73
	Kulite (App. 5\page 193)	73
7.2.2	Relative humidity/suction in dep. hole 5.	74
	Vaisala (App. 5\pages 194-197)	74
	Rotronic (App. 5\pages 198-202)	74
	Wescor Psychrometers (App.5\page 203)	74
7.2.3	Pore water pressure	75
	Geokon (App. 5\page 204)	75
	Kulite (App. 5\page 205)	75
7.2.4	Temperature in the buffer (App. 5\pages 206-215)	75
7.2.5	Canister power (App. 5\page 221)	75
7.2.6	Temperature on the canister surface (App. 5\pages 222-224)	76

7.3	Deposition hole 6	76
7.3.1	Total pressure	76
	Geokon and Kulite (App. 6\pages 227-230)	76
7.3.2	Relative humidity/Suction	77
	Vaisala and Rotronic (App. 6\pages 231-237)	77
	Wescor Psychrometers (App. 6\page 238-242)	77
7.3.3	Pore water pressure	77
	Geokon and Kulite (App. 6\pages 243-245)	77
7.3.4	Temperature in the buffer (App. 6\pages 246-259)	78
7.3.5	Canister power (App. 6\page 264)	78
7.3.6	Temperature on the canister surface (App. 6\pages 264-266)	78
7.4	Backfill in Section 2	79
7.4.1	Total pressure	79
	Geokon (App. 7\page 269)	79
	Kulite (App.7 \page 270)	79
7.4.2	Suction (App. 7 \pages 271-277)	80
7.4.3	Pore water pressure	80
	Geokon (App. 7\pages 278-280)	80
	Kulite (App. 7\page 281)	80
7.4.4	Temperature (App. 7\pages 282-284)	80
7.5	Temperature in the rock	81
7.5.1	Near hole 5 (App. 5\pages 216-220)	81
7.5.2	Near hole 6 (App. 6\pages 260-262)	81
7.6	Analyze of data from Section 2	81
7.6.1	Deposition hole 5.	81
7.6.2	Deposition hole 6.	84
7.6.3	Backfill	87
8	References	89
	Appendix 1. Deposition hole 1	91
	Appendix 2. Deposition hole 3	121
	Appendix 3. Deposition holes 2 and 4	153
	Appendix 4. Backfill in Section 1	165
	Appendix 5. Deposition hole 5	187
	Appendix 6. Deposition hole 6	225
	Appendix 7. Backfill in Section 2	267
	Appendix 8. Canister displacements	285
	Appendix 9. Geo-electric monitoring	305
	Appendix 10 Stress and strain in the rock	357
	Appendix 11. Water pressure in the rock	391
	Quick guide	459

1 Introduction

The Prototype Repository Test consists of two sections. The installation of the first Section of Prototype Repository was made during summer and autumn 2001 and Section 2 was installed in spring and summer 2003.

Section 1 consists of four full-scale deposition holes, copper canisters equipped with electrical heaters, bentonite blocks and a deposition tunnel backfilled with a mixture of bentonite and crushed rock and ends with a concrete plug as shown in Figure 1-1. Section 2 consists of two full-scale deposition holes with a backfilled tunnel section and ends also with a concrete plug.

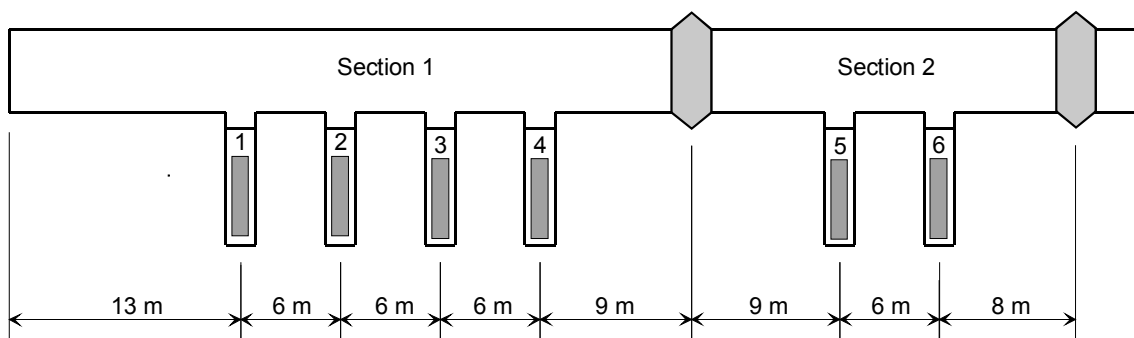

Figure 1-1. Schematic view of the Prototype Repository.

The bentonite buffer in deposition holes 1, 3, 5 and 6, the backfill and the surrounding rock are instrumented with gauges for measuring temperature, water pressure, total pressure, relative humidity, resistivity and canister displacement. The instruments are connected to data collection systems by cables protected by tubes, which are led through the rock in watertight lead throughs.

In general the data for Section 1 in this report are presented in diagrams covering the time period 2001-09-17 to 2008-12-01. The time axis in the diagrams represent number of days from start 2001-09-17, which is the day the heating of the canister in hole 1 was started. For Section 2 the date are presented in diagrams covering the time period 2003-05-08 to 2008-12-01, where 2003-05-08 is the day when the heating of the canister in hole 5 was started.

This report consists of several parts. In chapters 2, 3, 4 and 6 a test overview with the positions of those measuring points and a brief description of the instruments are shown. In chapter 5 the measured results from all measurements in Section 1, except canister displacement, stress and strain and water pressure in the rock and resistivity in the backfill and buffer, are presented and commented. Corresponding presentations and comments for Section 2 are made in chapter 7. The diagrams of those measured results are attached in Appendix 1-7. The results and comments of the measurements of canister displacement, resistivity in the backfill, stress and strain in the rock and water pressure in the rock are presented separately in Appendix 8-11.

A quick guide to the positions of the instruments in the buffer and backfill is enclosed as the last page.

2 Geometry and coordinate systems

The Prototype Repository consists of two sections as shown in Figure 1-1. The geometry and the coordinate system for the sensors are different for the deposition holes and the tunnel. The temperature sensors in the rock are defined with the same coordinate system as the deposition holes.

Deposition holes

In Section 1 the deposition holes are termed 1-4 according to Figure 1-1 and in Section 2 the deposition holes are termed 5 and 6. The coordinate system for these holes is shown in Figure 2-1. With the z -axis starting from the cement casting and the angle α counted anti-clockwise from direction A. Measurements are mainly made in four vertical sections A, B, C and D according to Figure 2-1. Direction A and C are placed in the tunnels axial direction with A headed against the end of the tunnel i.e. almost towards West.

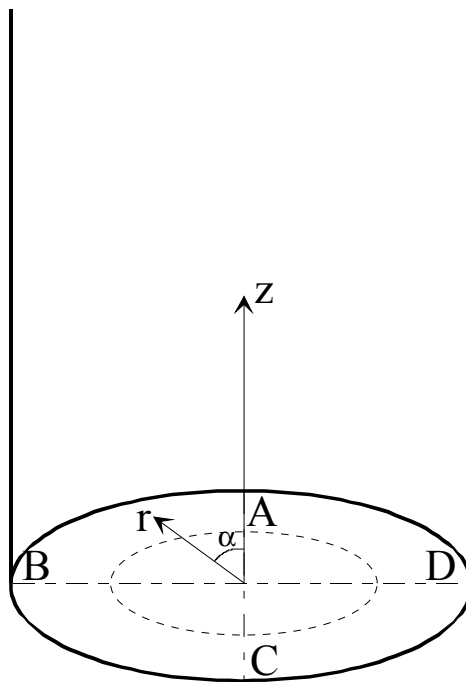

Figure 2-1. Figure describing the instrument planes (A-D) and the coordinate system used when describing the instrument positions.

Tunnel

The coordinate system of the backfill in the tunnel is shown in Figure 3-2. The coordinate y starts at the entrance on ground, which means that the tunnel ends at $y = 3599, 8$. The y -axis runs in the centre of the tunnel, which means that the tunnel walls intersect the z and x -axes at ± 2.5 m. The z -coordinate is determined positive upwards and the x -coordinate is determined positive to the right when facing the end of the tunnel.

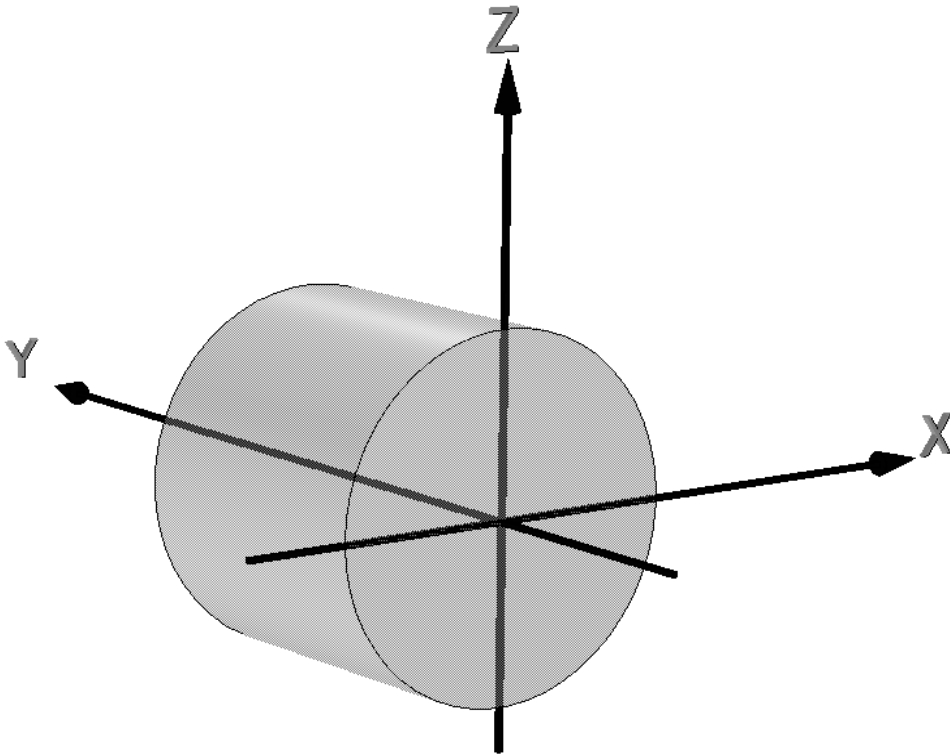

Figure 2-2. Coordinate system of the tunnel.

3 Brief description of the instruments

The different standard instruments that are used in the buffer, backfill and rock (temperature) are briefly described in this chapter.

Measurements of temperature

Buffer, backfill and rock

Thermocouples from Pentronic have been used to measure temperature. Measurements are done in 32 points in each instrumented hole (hole1 and hole 3). In addition, temperature gauges are built into the capacitive relative humidity sensors and some of the other sensor types as well.

Canister

Temperature is measured on the surface of the canister with optical fiber cables. An optical measuring system called FTR (Fiber Temperature Laser Radar) is used. In Section 2 are also three thermocouples of type Pentonic installed on each canister.

Measurement of total pressure in the buffer and backfill

Total pressure is the sum of the swelling pressure and the pore water pressure. It is measured with the following instrument types:

- Geocon total pressure cells with vibrating wire transducers.
- Kulite total pressure cells with piezo resistive transducers.

Measurement of pore water pressure in the buffer and backfill

Pore water pressure is measured with the following instrument types:

- Geocon pore pressure cells with vibrating wire transducer.
- Kulite pore pressure cells with piezo resistive transducer.

Measurement of the water saturation process in the buffer and backfill

The water saturation process is recorded by measuring the relative humidity in the pore system, which can be converted to total suction (negative water pressure). The following techniques and devices are used:

- Vaisala relative humidity sensor of capacitive type. The measuring range is 0-100 % RH.
- Rotronic relative humidity sensors of capacitive type. The measuring range is 0-100 % RH.
- Wescor soil psychrometer. The sensor is measuring the dry and the wet temperature in the pore volume of the material. The measuring range is 95.5-99.6 % RH corresponding to the pore water pressure -0.5 to -6 MPa. Psychrometers are placed in the backfill in both sections and in the buffer in the two deposition holes in Section 2.

4 Location of instruments in Section 1

4.1 Strategy for describing the position of each device in the bentonite and rock in and around the deposition holes

The same principles are used for describing the position of all sensors in the bentonite inside the deposition holes as well as the thermocouples in the rock around the deposition holes. The principles are described in the quick guide inserted as a folded A3 page at the end of the report.

Every instrument is named with a unique name consisting of 1 letter describing the type of measurement, 2 letters describing where the measurement takes place (buffer, backfill, rock or canister), 1 figure denoting the deposition hole (1-4) and 4 figures specifying the instrument according to a separate list (see Table 2-1 to 2-10). Every instrument position is then described with three coordinates according to Figure 3-1.

The r -coordinate is the horizontal distance from the centre of the hole and the z -coordinate is the height from the surface of the bottom casting of the hole (the block height is set to 500mm). The α -coordinate is the angle from the vertical direction A (almost West).

Figure 4-1 shows an overview of the instruments in the buffer. The bentonite blocks are called cylinders and rings. The cylinders are numbered C1-C4 and the rings R1-R10 respectively.

- pore water pressure + temp.
- total pressure + temp.
- × temp.
- △ relative humidity (+ temp.)

1m

A

B+C

D

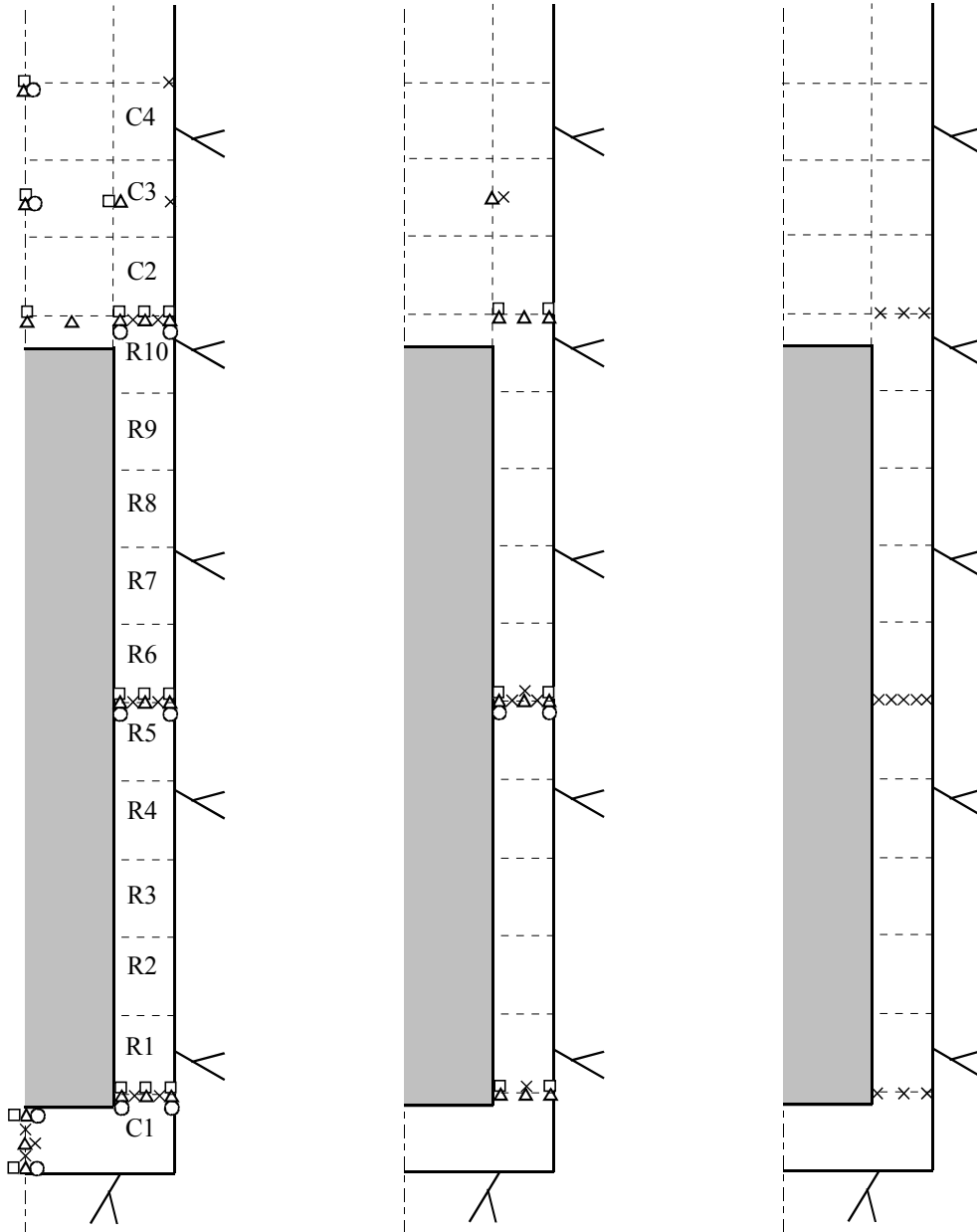

Figure 4-1. Schematic view over the instruments in four vertical sections and the block designation.

4.2 Position of each instrument in the bentonite in hole 1 (DA3587G01)

The instruments are located in three main levels in the blocks, 50 mm, 160 mm and 250 mm, from the upper surface. The thermocouples are mostly placed in the 50 mm level and the other gauges in the 160 mm level except for the Geokon type 1 pressure sensors and the Rotronic humidity sensors, which are placed in the 250 mm level depending on the size of the sensor house.

Exact positions of the sensors are described in Tables 4-1 to 4-4.

Table 4-1. Numbering and position of instruments for measuring temperature (T) in the buffer in hole 1.

Type and number	Block	Instrument position				Fabricate	Remark
		Direction	α degree	r m	Z m		
TBU10001	Cyl. 1	Center	270	0,050	0,054	Pentronic	
TBU10002	Cyl. 1	Center	270	0,050	0,254	Pentronic	
TBU10003	Cyl. 1	Center	270	0,050	0,454	Pentronic	
TBU10004	Cyl. 1	A	355	0,635	0,454	Pentronic	
TBU10005	Cyl. 1	A	355	0,735	0,454	Pentronic	
TBU10006	On top of the canister in hole 2					Pentronic	
TBU10007	Cyl. 1	C	175	0,685	0,454	Pentronic	
TBU10008	Cyl. 1	D	270	0,585	0,454	Pentronic	
TBU10009	Cyl. 1	D	270	0,685	0,454	Pentronic	
TBU10010	Cyl. 1	D	270	0,785	0,454	Pentronic	
TBU10011	Ring 5	A	0	0,635	2,980	Pentronic	
TBU10012	Ring 5	A	0	0,735	2,980	Pentronic	
TBU10013	Ring 5	B	90	0,585	2,980	Pentronic	
TBU10014	Ring 5	B	90	0,685	2,980	Pentronic	
TBU10015	Ring 5	B	90	0,785	2,980	Pentronic	
TBU10016	Ring 5	C	175	0,585	2,980	Pentronic	
TBU10017	Ring 5	C	175	0,685	2,980	Pentronic	
TBU10018	Ring 5	C	175	0,735	2,980	Pentronic	
TBU10019	Ring 5	D	270	0,585	2,980	Pentronic	
TBU10020	Ring 5	D	270	0,635	2,980	Pentronic	
TBU10021	Ring 5	D	270	0,685	2,980	Pentronic	
TBU10022	Ring 5	D	270	0,735	2,980	Pentronic	
TBU10023	Ring 5	D	270	0,785	2,980	Pentronic	
TBU10024	Ring 10	A	0	0,635	5,508	Pentronic	
TBU10025	Ring 10	A	0	0,735	5,508	Pentronic	
TBU10026	Ring 10	D	270	0,585	5,508	Pentronic	
TBU10027	Ring 10	D	270	0,685	5,508	Pentronic	
TBU10028	Ring 10	D	270	0,785	5,508	Pentronic	
TBU10029	Cyl. 3	A	0	0,785	6,317	Pentronic	
TBU10030	Cyl. 3	B	95	0,585	6,317	Pentronic	
TBU10031	Cyl. 3	C	185	0,585	6,317	Pentronic	
TBU10032	Cyl. 4	A	0	0,785	7,026	Pentronic	

Table 4-2. Numbering and position of instruments for measuring total pressure (P) in the buffer in hole 1.

Type and number	Block	Instrument position				Fabricate	Remark
		Direction	α degree	r m	Z m		
PBU10001	Cyl. 1	Center	0	0,000	0,000	Geokon	In cement
PBU10002	Cyl. 1	Center	0	0,100	0,504	Geokon	
PBU10003	Cyl. 1	A	5	0,585	0,504	Kulite	Vertical
PBU10004	Cyl. 1	A	5	0,685	0,504	Kulite	Vertical
PBU10005	Cyl. 1	A	5	0,785	0,504	Kulite	Vertical
PBU10006	Cyl. 1	B	95	0,635	0,504	Geokon	
PBU10007	Cyl. 1	B	105	0,735	0,504	Geokon	
PBU10008	Cyl. 1	C	185	0,635	0,504	Geokon	
PBU10009	Cyl. 1	C	195	0,735	0,504	Geokon	
PBU10011	Ring 5	A	5	0,685	2,780	Geokon I	
PBU10012	Ring 5	A	5	0,785	3,030	Kulite	In the slot
PBU10013	Ring 5	B	95	0,585	2,780	Geokon I	
PBU10014	Ring 5	B	95	0,785	2,780	Geokon I	
PBU10015	Ring 5	C	185	0,535	3,030	Geokon I	In the slot
PBU10016	Ring 5	C	185	0,825	2,870	Kulite	In the slot
PBU10017	Ring 10	Center	0	0,050	5,558	Geokon	
PBU10019	Ring 10	A	5	0,685	5,558	Kulite	Vertical
PBU10020	Ring 10	A	5	0,785	5,558	Kulite	Vertical
PBU10021	Ring 10	B	90	0,635	5,558	Geokon	
PBU10022	Ring 10	B	100	0,735	5,558	Geokon	
PBU10023	Ring 10	C	190	0,735	5,558	Geokon	
PBU10024	Ring 10	C	180	0,635	5,558	Geokon	
PBU10025	Cyl. 3	Center	0	0,050	6,317	Kulite	Vertical
PBU10026	Cyl. 3	A	5	0,585	6,567	Geokon	
PBU10027	Cyl. 4	Center	0	0,050	7,076	Kulite	Vertical

Table 4-3. Numbering and position of instruments for measuring pore water pressure (U) in the buffer in hole 1.

Type and number	Block	Instrument position				Fabricate	Remark
		Direction	α degree	r m	Z m		
UBU10001	Cyl. 1	Center	90	0,050	0,054	Kulite	
UBU10002	Cyl. 1	Center	90	0,050	0,254	Geokon	Horizontal
UBU10003	Cyl. 1	A	355	0,585	0,344	Geokon	
UBU10004	Cyl. 1	A	355	0,785	0,344	Kulite	
UBU10005	Ring 5	A	355	0,585	2,780	Geokon	
UBU10006	Ring 5	A	355	0,785	2,870	Kulite	
UBU10007	Ring 5	B	85	0,535	2,870	Kulite	In the slot
UBU10008	Ring 5	B	85	0,825	2,870	Kulite	In the slot
UBU10009	Ring 5	C	175	0,535	2,780	Geokon	In the slot
UBU10010	Ring 5	C	175	0,825	2,780	Geokon	In the slot
UBU10011	Ring 10	A	355	0,585	5,398	Kulite	
UBU10012	Ring 10	A	355	0,785	5,308	Geokon	
UBU10013	Cyl. 3	Center	90	0,050	6,317	Geokon	
UBU10014	Cyl. 4	Center	90	0,050	6,916	Geokon	

Table 4-4. Numbering and position of instruments for measuring water content (W) in the buffer in hole 1.

Type and number	Block	Instrument position				Fabricate	Remark
		Direction	α degree	r m	Z m		
WBU10001	Cyl. 1	Center	180	0,050	0,054	Rotronic	
WBU10002	Cyl. 1	Center	0	0,400	0,254	Rotronic	
WBU10003	Cyl. 1	Center	180	0,100	0,254	Rotronic	Horizontal
WBU10004	Cyl. 1	A	350	0,785	0,344	Vaisala	
WBU10005	Cyl. 1	A	350	0,685	0,344	Vaisala	
WBU10006	Cyl. 1	A	350	0,585	0,344	Vaisala	
WBU10007	Cyl. 1	B	80	0,585	0,344	Vaisala	
WBU10008	Cyl. 1	B	80	0,685	0,254	Rotronic	
WBU10009	Cyl. 1	B	80	0,785	0,254	Rotronic	
WBU10010	Cyl. 1	C	170	0,585	0,254	Rotronic	
WBU10011	Cyl. 1	C	170	0,685	0,254	Rotronic	
WBU10012	Cyl. 1	C	170	0,785	0,254	Rotronic	
WBU10013	Ring 5	A	350	0,585	2,870	Vaisala	
WBU10014	Ring 5	A	350	0,685	2,870	Vaisala	
WBU10015	Ring 5	A	350	0,785	2,870	Vaisala	
WBU10016	Ring 5	B	80	0,535	2,780	Rotronic	In the slot
WBU10017	Ring 5	B	80	0,685	2,780	Rotronic	
WBU10018	Ring 5	B	80	0,785	2,780	Rotronic	
WBU10019	Ring 5	C	180	0,535	2,870	Vaisala	In the slot
WBU10020	Ring 5	C	180	0,685	2,870	Vaisala	
WBU10021	Ring 5	C	180	0,785	2,780	Rotronic	
WBU10022	Ring 10	Center	0	0,050	5,418	Vaisala	
WBU10023	Ring 10	A	180	0,362	5,428	Vaisala	
WBU10024	Ring 10	A	350	0,585	5,398	Vaisala	
WBU10025	Ring 10	A	350	0,685	5,398	Vaisala	
WBU10026	Ring 10	A	350	0,785	5,398	Vaisala	
WBU10027	Ring 10	B	80	0,585	5,308	Rotronic	
WBU10028	Ring 10	B	80	0,685	5,308	Rotronic	
WBU10029	Ring 10	B	80	0,785	5,308	Rotronic	
WBU10030	Ring 10	C	170	0,585	5,398	Vaisala	
WBU10031	Ring 10	C	170	0,785	5,308	Rotronic	
WBU10032	Cyl. 3	Center	270	0,050	6,317	Vaisala	
WBU10033	Cyl. 3	A	350	0,585	6,317	Vaisala	
WBU10034	Cyl. 3	B	90	0,585	6,317	Vaisala	
WBU10035	Cyl. 3	C	180	0,585	6,317	Rotronic	
WBU10036	Cyl. 4	Center	180	0,050	6,916	Vaisala	
WBU10037	Cyl. 4	Center	270	0,050	6,756	Vaisala	

4.3 Position of each instrument in the bentonite in hole 3 (DA3575G01)

The instruments are located according to the same system as those in hole 1.

The positions of each instrument are described in Tables 4-6 to 4-10.

Table 4-6. Numbering and position of instruments for measuring temperature (T) in the buffer in hole 3.

Type and number	Block	Instrument position				Fabricate	Remark
		Direction	α degree	r m	Z m		
TBU30001	Cyl. 1	Center	270	0,050	0,095	Pentronic	
TBU30002	Cyl. 1	Center	270	0,050	0,295	Pentronic	
TBU30003	Cyl. 1	Center	270	0,050	0,445	Pentronic	
TBU30004	Cyl. 1	A	355	0,635	0,445	Pentronic	
TBU30005	Cyl. 1	A	355	0,735	0,445	Pentronic	
TBU30006	Cyl. 1	B	85	0,685	0,445	Pentronic	
TBU30007	Cyl. 1	C	175	0,685	0,445	Pentronic	
TBU30008	Cyl. 1	D	270	0,585	0,445	Pentronic	
TBU30009	Cyl. 1	D	270	0,685	0,445	Pentronic	
TBU30010	Cyl. 1	D	270	0,785	0,445	Pentronic	
TBU30011	Ring 5	A	0	0,635	2,971	Pentronic	
TBU30012	Ring 5	A	0	0,735	2,971	Pentronic	
TBU30013	Ring 5	B	90	0,585	2,971	Pentronic	
TBU30014	Ring 5	B	90	0,685	2,971	Pentronic	
TBU30015	Ring 5	B	90	0,785	2,971	Pentronic	
TBU30016	Ring 10	A	329	0,410	5,394	Pentronic	Just above canister lid
TBU30017	Ring 5	C	175	0,685	2,971	Pentronic	
TBU30018	Ring 5	C	175	0,735	2,971	Pentronic	
TBU30019	Ring 5	D	270	0,585	2,971	Pentronic	
TBU30020	Ring 5	D	270	0,635	2,971	Pentronic	
TBU30021	Ring 5	D	270	0,685	2,971	Pentronic	
TBU30022	Ring 5	D	270	0,735	2,971	Pentronic	
TBU30023	Ring 5	D	270	0,785	2,971	Pentronic	
TBU30024	Ring 10	A	0	0,635	5,504	Pentronic	
TBU30025	Ring 10	A	0	0,735	5,504	Pentronic	
TBU30026	Ring 10	D	270	0,585	5,504	Pentronic	
TBU30027	Ring 10	D	270	0,685	5,504	Pentronic	
TBU30028	Ring 10	D	270	0,785	5,504	Pentronic	
TBU30029	Cyl. 3	A	0	0,785	6,314	Pentronic	
TBU30030	Cyl. 3	B	95	0,585	6,314	Pentronic	
TBU30031	Cyl. 3	C	185	0,585	6,314	Pentronic	
TBU30032	Cyl. 4	A	0	0,785	7,015	Pentronic	

Table 4-7. Numbering and position of instruments for measuring total pressure (P) in the buffer in hole 3.

Type and number	Block	Instrument position in block					Remark
		Direction	α degree	r mm	Z mm	Fabricate	
PBU30001	Cyl. 1	Center	0	0	0	Geokon	In cement
PBU30002	Cyl. 1	Center	0	100	495	Geokon	
PBU30003	Cyl. 1	A	5	585	495	Kulite	Vertical
PBU30004	Cyl. 1	A	5	685	495	Kulite	Vertical
PBU30005	Cyl. 1	A	5	785	495	Kulite	Vertical
PBU30006	Cyl. 1	B	95	635	495	Geokon	
PBU30007	Cyl. 1	B	105	735	495	Geokon	
PBU30008	Cyl. 1	C	185	635	495	Geokon	
PBU30009	Cyl. 1	C	195	735	495	Geokon	
PBU30010	Ring 5	A	5	535	3021	Kulite	In the slot
PBU30011	Ring 5	A	5	685	2771	Geokon I	
PBU30012	Ring 5	A	5	825	3021	Kulite	In the slot
PBU30013	Ring 5	B	95	585	2771	Geokon I	
PBU30014	Ring 5	B	95	785	2771	Geokon I	
PBU30015	Ring 5	C	185	535	3021	Geokon I	In the slot
PBU30016	Ring 5	C	185	825	2971	Kulite	In the slot
PBU30017	Ring 10	Center	0	50	5556	Geokon	
PBU30018	Ring 10	A	5	585	5556	Kulite	Vertical
PBU30019	Ring 10	A	5	685	5556	Kulite	Vertical
PBU30020	Ring 10	A	5	785	5556	Kulite	Vertical
PBU30021	Ring 10	B	90	635	5556	Geokon	
PBU30022	Ring 10	B	100	735	5556	Geokon	
PBU30023	Ring 10	C	180	735	5556	Geokon	
PBU30024	Ring 10	C	190	635	5556	Geokon	
PBU30025	Cyl. 3	Center	0	50	6314	Kulite	Vertical
PBU30026	Cyl. 3	A	5	585	6564	Geokon	
PBU30027	Cyl. 4	Center	0	50	7065	Kulite	Vertical

Table 4-8. Numbering and position of instruments for measuring pore water pressure (U) in the buffer in hole 3.

Type and number	Block	Instrument position in block				Fabricate	Remark
		Direction	α degree	r mm	Z mm		
UBU30001	Cyl. 1	Center	90	50	45	Kulite	
UBU30002	Cyl. 1	Center	90	100	245	Geokon	Horizontal
UBU30003	Cyl. 1	A	355	585	335	Geokon	
UBU30004	Cyl. 1	A	355	785	335	Kulite	
UBU30005	Ring 5	A	355	585	2771	Geokon	
UBU30006	Ring 5	A	355	785	2861	Kulite	
UBU30007	Ring 5	B	85	535	2861	Kulite	In the slot
UBU30008	Ring 5	B	85	825	2861	Kulite	In the slot
UBU30009	Ring 5	C	175	535	2771	Geokon	In the slot
UBU30010	Ring 5	C	175	825	2771	Geokon	In the slot
UBU30011	Ring 10	A	355	585	5396	Kulite	
UBU30012	Ring 10	A	355	785	5306	Geokon	
UBU30013	Cyl. 3	Center	90	50	6314	Geokon	
UBU30014	Cyl. 4	Center	90	50	6910	Geokon	

Table 4-9. Numbering and position of instruments for measuring water content (W) in the buffer in hole 3.

Type and number	Block	Instrument position				Fabricate	Remark
		Direction	α degree	r m	Z m		
WBU30001	Cyl. 1	Center	180	0,050	0,045	Rotronic	
WBU30002	Cyl. 1	Center	0	0,400	0,215	Rotronic	
WBU30003	Cyl. 1	Center	180	0,100	0,245	Rotronic	Horizontal
WBU30004	Cyl. 1	A	350	0,785	0,335	Vaisala	
WBU30005	Cyl. 1	A	350	0,685	0,335	Vaisala	
WBU30006	Cyl. 1	A	350	0,585	0,335	Vaisala	
WBU30007	Cyl. 1	B	80	0,585	0,335	Vaisala	
WBU30008	Cyl. 1	B	80	0,685	0,245	Rotronic	
WBU30009	Cyl. 1	B	80	0,785	0,245	Rotronic	
WBU30010	Cyl. 1	C	170	0,585	0,245	Rotronic	
WBU30011	Cyl. 1	C	170	0,685	0,245	Rotronic	
WBU30012	Cyl. 1	C	170	0,785	0,245	Rotronic	
WBU30013	Ring 5	A	350	0,585	2,861	Vaisala	
WBU30014	Ring 5	A	350	0,685	2,861	Vaisala	
WBU30015	Ring 5	A	350	0,785	2,861	Vaisala	
WBU30016	Ring 5	B	80	0,535	2,771	Rotronic	In the slot
WBU30017	Ring 5	B	80	0,685	2,771	Rotronic	
WBU30018	Ring 5	B	80	0,785	2,771	Rotronic	
WBU30019	Ring 5	C	180	0,535	2,861	Vaisala	In the slot
WBU30020	Ring 5	C	180	0,685	2,861	Vaisala	
WBU30021	Ring 5	C	180	0,785	2,771	Rotronic	
WBU30022	Ring 10	Center	180	0,050	5,416	Vaisala	
WBU30023	Ring 10	A	352	0,262	5,396	Vaisala	
WBU30024	Ring 10	A	350	0,585	5,396	Vaisala	
WBU30025	Ring 10	A	350	0,785	5,396	Vaisala	
WBU30026	Ring 10	A	350	0,685	5,396	Vaisala	
WBU30027	Ring 10	B	80	0,585	5,306	Rotronic	
WBU30028	Ring 10	B	80	0,685	5,306	Rotronic	
WBU30029	Ring 10	B	80	0,785	5,306	Rotronic	
WBU30030	Ring 10	C	170	0,585	5,396	Vaisala	
WBU30031	Ring 10	C	170	0,785	5,306	Rotronic	
WBU30032	Cyl. 3	Center	180	0,050	6,314	Vaisala	
WBU30033	Cyl. 3	A	350	0,585	6,314	Vaisala	
WBU30034	Cyl. 3	B	90	0,585	6,314	Vaisala	
WBU30035	Cyl. 3	C	180	0,585	6,314	Rotronic	
WBU30036	Cyl. 4	Center	180	0,050	6,910	Vaisala	
WBU30037	Cyl. 4	Center	270	0,050	6,750	Vaisala	

4.4 Instruments on the canister surface in holes 1-4

The canisters are instrumented with optical fiber cables on the copper surface.

Figure 4-2 shows how two optical fiber cables are placed on the canister surface. Both ends of a cable are used for measurements. This means that the two cables are used for four measurements.

With this laying the cables will enter and exit the surface at almost the same position. Curvatures are shaped as a quarter circle with a radius of 20 cm. The cables are placed in a milled out channels on the surface. The channels have a width and a depth of just above 2 mm

In addition to the optical cables one thermocouple (TBU 10006) is fixed to the lid of the canister in deposition hole 2 (see Table 4-1).

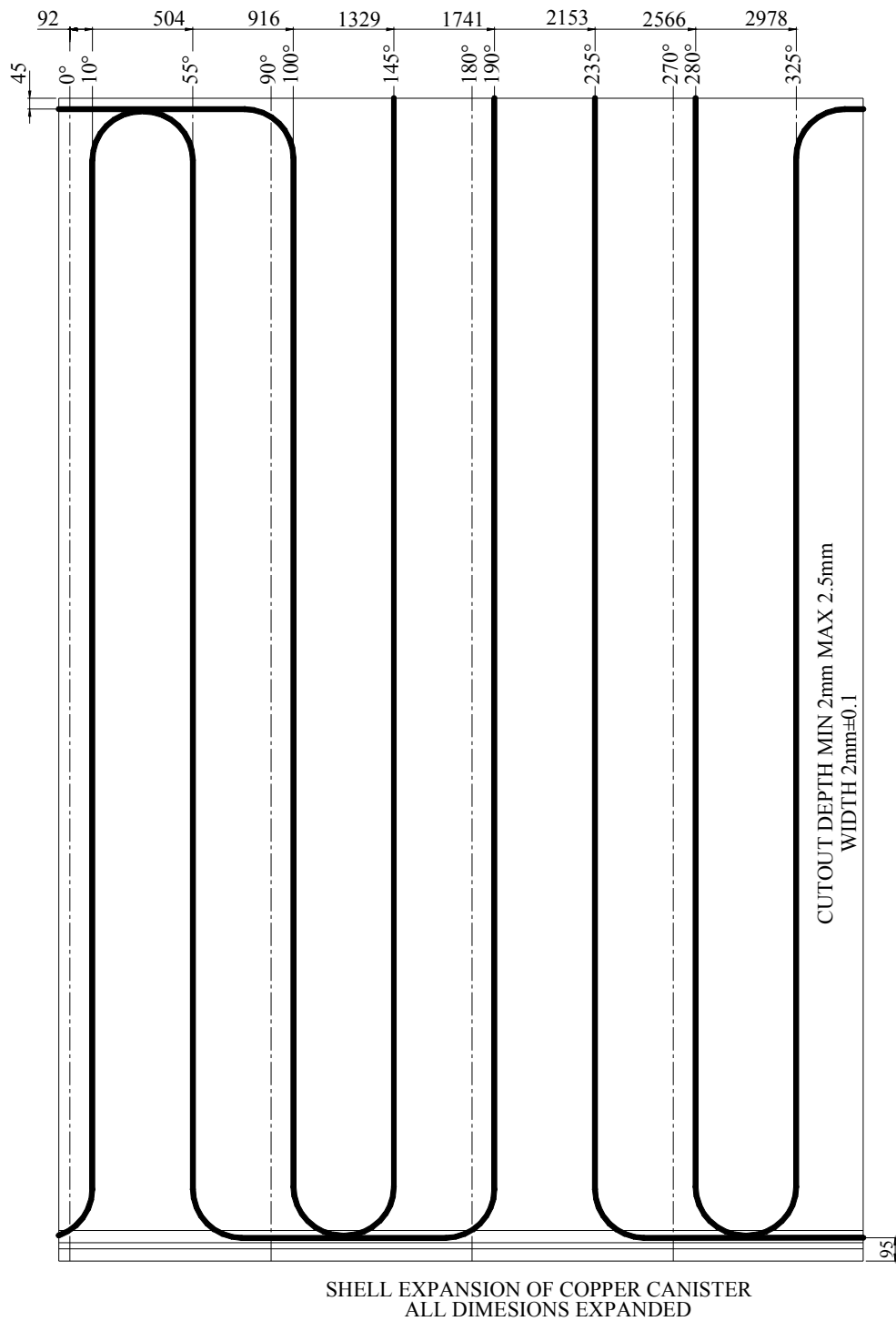

Figure 4-2. Laying of the optical fiber cables with protection tube of Inconel 625 (outer diameter 2 mm) for measurement of the canister surface temperature (surface unfolded).

4.5 Position of temperature sensors in the rock

The positions of the temperature sensors in the rock are termed in the same way as the sensors in the buffer in the deposition holes. Figure 4-3 shows an overview of the temperature sensors placed in the rock. The sensors are assigned to the closest deposition hole. The positions are described in Table 4-10.

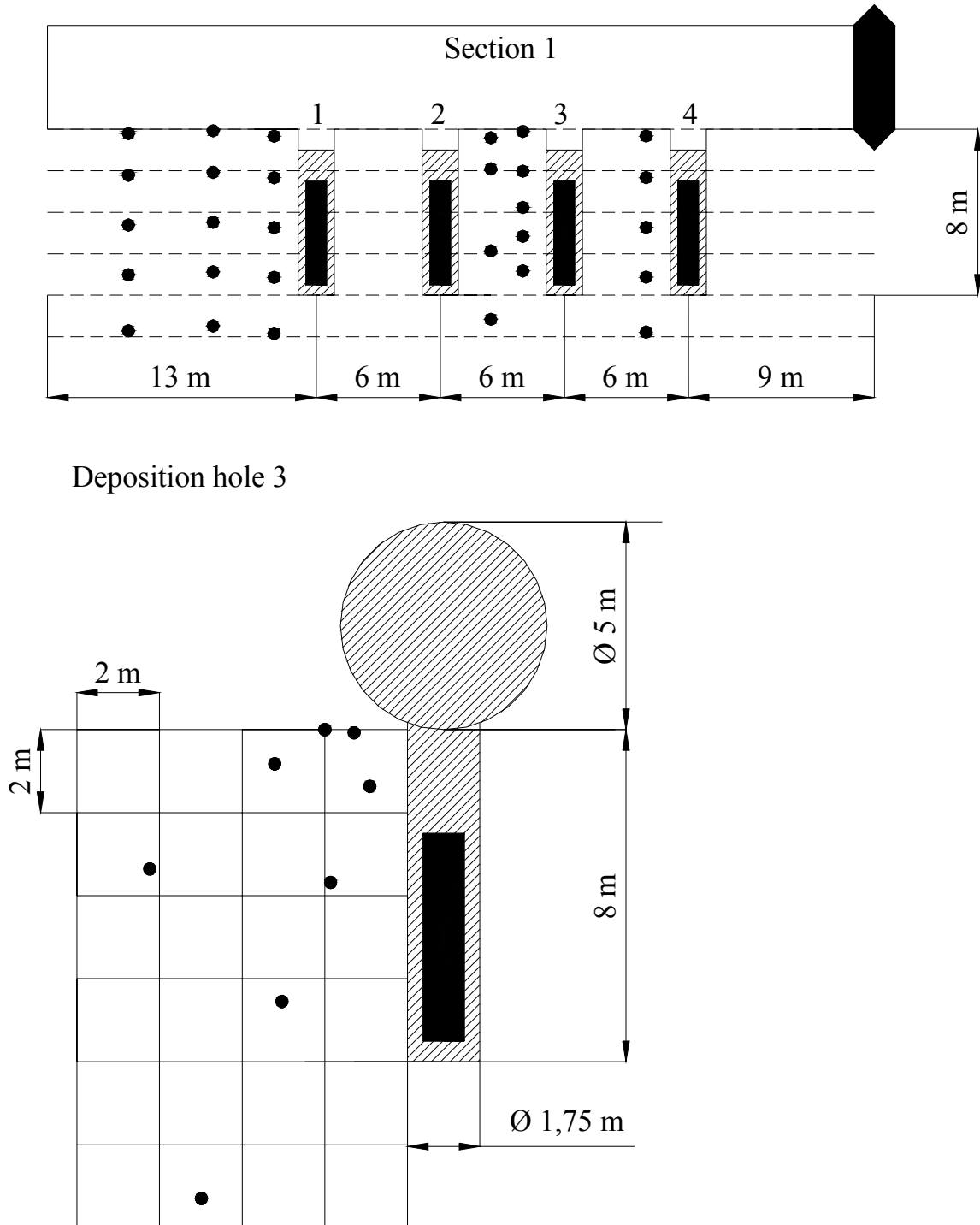

Figure 4-3. Overview of the temperature sensors in the rock. Length section (upper) and cross section (towards the end of the tunnel).

Table 4-10. Numbering and position of temperature sensors in the rock.

Instrument position in rock				
Type and number	α	r	Z	Fabricate
	degree	m	m	
Measured from DA3587G01(Hole 1)				
TROA0350	360	9,080	7,785	Pentronic
TROA0340	360	9,080	5,785	Pentronic
TROA0330	360	9,080	3,385	Pentronic
TROA0320	0	9,080	0,986	Pentronic
TROA0310	0	9,081	-1,714	Pentronic
TROA0650	360	4,990	7,922	Pentronic
TROA0640	360	4,982	5,922	Pentronic
TROA0630	360	4,972	3,522	Pentronic
TROA0620	360	4,961	1,122	Pentronic
TROA0610	360	4,951	-1,478	Pentronic
TROA1050	359	2,014	7,663	Pentronic
TROA1040	359	2,022	5,663	Pentronic
TROA1030	359	2,032	3,263	Pentronic
TROA1020	359	2,042	0,863	Pentronic
TROA1010	359	2,053	-1,837	Pentronic
Measured from DA3581G01(Hole 2)				
TROA1840	179	2,403	7,584	Pentronic
TROA1830	179	2,427	6,084	Pentronic
TROA1820	179	2,489	2,135	Pentronic
TROA1810	179	2,541	-1,165	Pentronic
Measured from DA3575G01(Hole 3)				
TROA2150	134	3,287	7,956	Pentronic
TROA2140	1	1,993	5,977	Pentronic
TROA2130	1	1,975	4,228	Pentronic
TROA2120	2	1,961	2,838	Pentronic
TROA2110	3	1,944	1,168	Pentronic
TROA1850	360	2,013	7,887	Pentronic
TROA2330	90	2,192	7,922	Pentronic
TROA2320	90	1,786	6,630	Pentronic
TROA2310	109	7,111	4,638	Pentronic
TROA2440	124	4,090	7,172	Pentronic
TROA2430	90	2,735	4,317	Pentronic
TROA2420	89	3,912	1,449	Pentronic
TROA2410	89	5,86	-3,297	Pentronic
Measured from DA3569G01 (Hole 4)				
TROA3050	359	2,013	7,665	Pentronic
TROA3040	359	2,020	5,665	Pentronic
TROA3030	358	2,030	3,265	Pentronic
TROA3020	357	2,040	0,865	Pentronic
TROA3010	357	2,051	-1,784	Pentronic

4.6 Strategy for describing the position of each device in the backfill in section 1

The principles of terming the instruments are described in the quick guide inserted as a folded A3 page at the end of the report.

Every instrument is named with a unique name consisting of 1 letter describing the type of measurement, 2 letters describing where the measurement takes place (buffer, backfill, rock or canister) and 5 figures specifying the instrument according to separate lists (see Tables 4-11 to 4-14). Every instrument position is then described with three coordinates according to Figure 2-2. The *x*-coordinate is the horizontal distance from the centre of the tunnel and the *z*-coordinate is the vertical distance from the centre of the tunnel. The *y*-coordinate is the same as in the tunnel coordinate system, i.e. *y*=3599 corresponds to the end of the tunnel.

The backfill is mainly instrumented in vertical sections straight above and between the deposition holes (Figures 4-4 and 4-5).

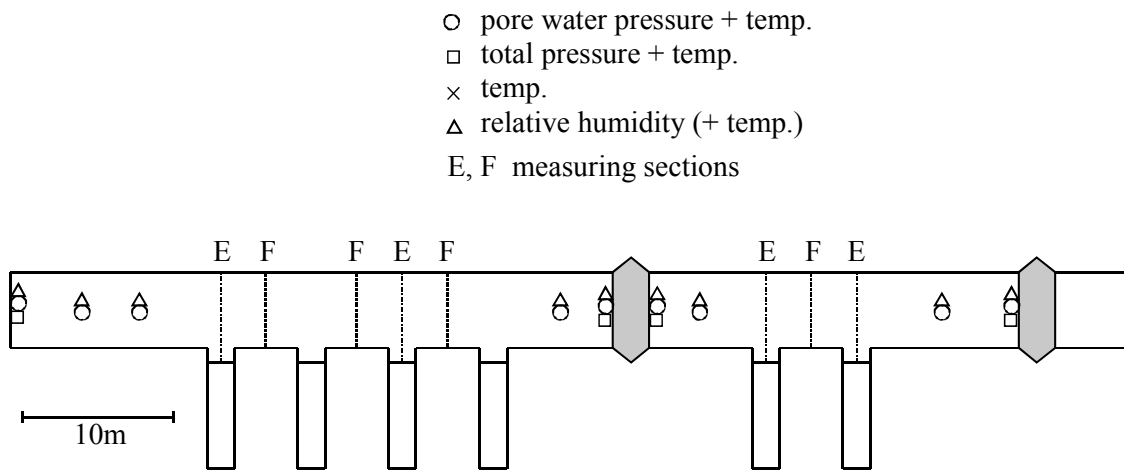

Figure 4-4. Schematic view over the instrumentation of the backfill.

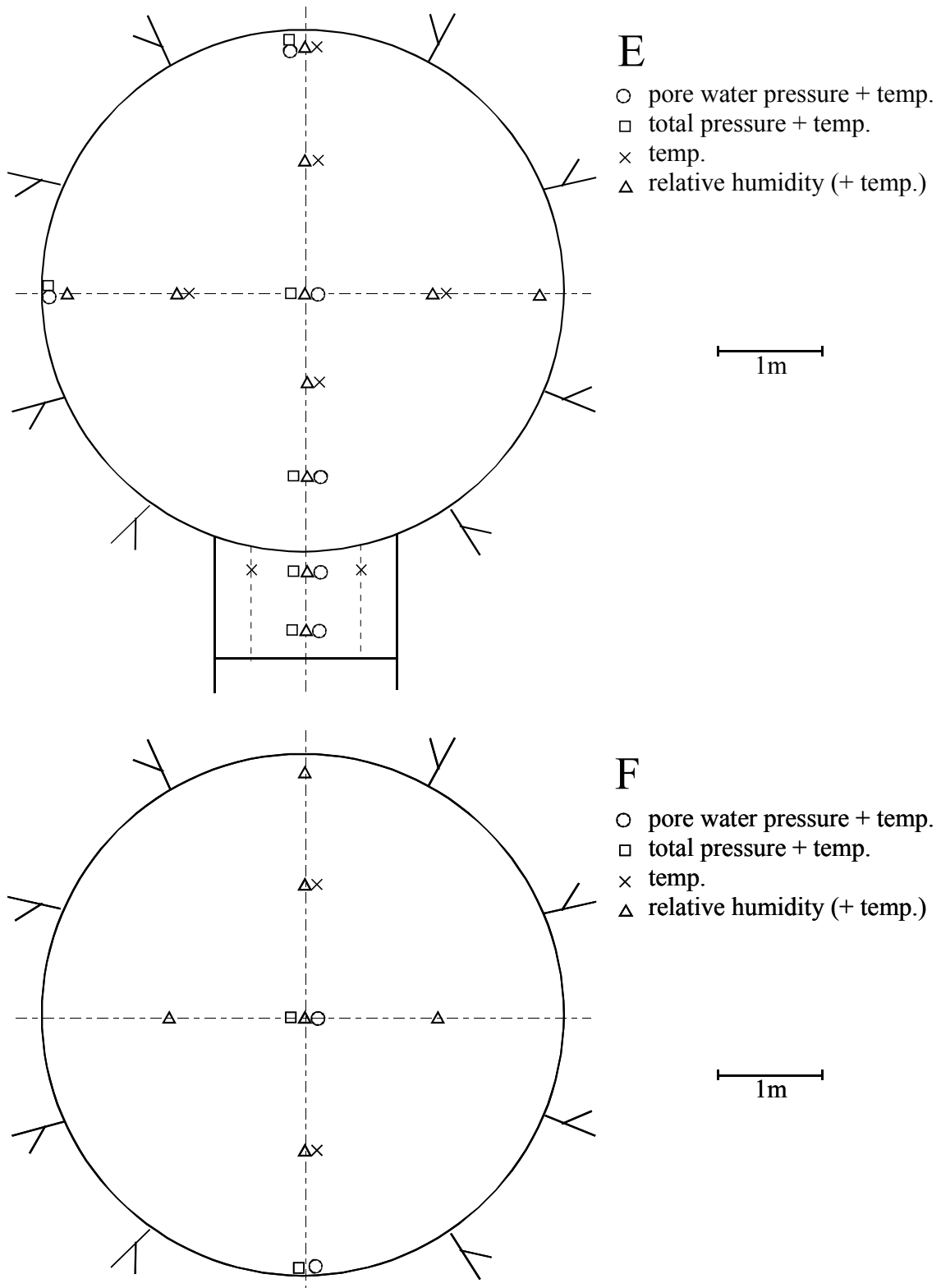

Figure 4-5. Schematic view over the sensors positions in the different sections.

4.7 Position of each instrument in the backfill

The positions of each instrument are described in Tables 4-11 to 4-14.

Table 4-11. Numbering and position of instruments for measuring temperature (T) in the backfill.

Type and number	Instrument position			Fabricate	Remark
	Section	x	z		
		m	m	m	
TBA10001	E, over dep.hole 1	-1,3	-0,1	3 587	Pentronic
TBA10002	E, over dep.hole 1	0,1	1,3	3 587	Pentronic
TBA10003	E, over dep.hole 1	0,0	-0,8	3 587	Pentronic
TBA10004	E, over dep.hole 1	-0,5	-2,6	3 587	Pentronic
TBA10005	E, over dep.hole 1	0,5	-2,6	3 587	Pentronic
TBA10006	E, over dep.hole 1	-0,1	2,3	3 587	Pentronic
TBA10007	E, over dep.hole 1	1,3	-0,1	3 587	Pentronic
TBA10008	F, between dep.hole 1 and 2	0,0	1,3	3 584	Pentronic
TBA10009	F, between dep.hole 1 and 2	-0,1	-1,3	3 584	Pentronic
TBA10010	F, between dep.hole 2 and 3	0,0	1,2	3 578	Pentronic
TBA10011	F, between dep.hole 2 and 3	0,0	-1,2	3 578	Pentronic
TBA10012	E, over dep.hole 3	-0,1	2,3	3 575	Pentronic
TBA10013	E, over dep.hole 3	0,0	1,3	3 575	Pentronic
TBA10014	E, over dep.hole 3	0,0	-0,9	3 575	Pentronic
TBA10015	E, over dep.hole 3	-0,5	-2,6	3 575	Pentronic
TBA10016	E, over dep.hole 3	0,5	-2,6	3 575	Pentronic
TBA10017	E, over dep.hole 3	-1,3	0,0	3 575	Pentronic
TBA10018	E, over dep.hole 3	1,3	0,0	3 575	Pentronic
TBA10019	F, between dep.hole 3 and 4	0,0	1,2	3 572	Pentronic
TBA10020	F, between dep.hole 3 and 4	0,0	-1,3	3 572	Pentronic

Table 4-12. Numbering and position of instruments for measuring total pressure (P) in the backfill.

Type and number	Instrument position			Fabricate	Remark
	Section	x	z		
		m	m	m	
PBA10001	Inner part	0,2	0,1	3589	Kulite
PBA10002	E, over dep.hole 1	0,0	0,0	3587	Geokon
PBA10003	E, over dep.hole 1	0,0	-1,8	3587	Geokon
PBA10004	E, over dep.hole 1	0,0	-2,6	3587	Geokon
PBA10005	E, over dep.hole 1	0,0	-3,1	3587	Kulite
PBA10006	E, over dep.hole 1	-2,3	0,1	3587	Kulite
PBA10007	E, over dep.hole 1	0,2	2,3	3587	Kulite
PBA10008	F, between dep.hole 1 and 2	0,0	0,0	3584	Geokon
PBA10009	F, between dep.hole 1 and 2	-0,1	-1,8	3584	Geokon
PBA10010	F, between dep.hole 2 and 3	0,0	-0,2	3578	Kulite
PBA10011	F, between dep.hole 2 and 3	0,0	-2,3	3578	Kulite
PBA10013	E, over dep.hole 3	0,0	-1,8	3575	Kulite
PBA10015	E, over dep.hole 3	0,0	-3,1	3575	Geokon
PBA10016	E, over dep.hole 3	-2,3	0,0	3575	Geokon
PBA10017	E, over dep.hole 3	0,0	0,0	3575	Geokon
PBA10018	F, between dep.hole 3 and 4	0,0	0,0	3572	Geokon
PBA10019	F, between dep.hole 3 and 4	0,0	-2,3	3572	Geokon
PBA10020	In front of plug	0,0	0,0	3561	Kulite

Table 4-13. Numbering and position of instruments for measuring pore water pressure (U) in the backfill.

Type and number	Instrument position			Fabricate	Remark
	Section	x	z		
		m	m	m	
UBA10001	Inner part	-0,2	-0,1	3589	Kulite
UBA10002	Inner part	0,0	0,0	3592	Geokon
UBA10003	Inner part	-0,2	-0,1	3590	Geokon
UBA10004	E, over dep.hole 1	0,0	-0,1	3587	Geokon
UBA10005	E, over dep.hole 1	-0,2	-1,8	3587	Kulite
UBA10006	E, over dep.hole 1	0,1	-2,6	3587	Kulite
UBA10007	E, over dep.hole 1	0,4	-3,2	3587	Kulite
UBA10008	E, over dep.hole 1	-2,3	0,0	3587	Geokon
UBA10009	E, over dep.hole 1	0,0	2,3	3587	Geokon
UBA10010	F, between dep.hole 1 and 2	0,0	0,0	3584	Kulite
UBA10011	F, between dep.hole 1 and 2	0,1	-1,8	3584	Kulite
UBA10012	F, between dep.hole 2 and 3	0,0	-0,2	3578	Kulite
UBA10013	F, between dep.hole 2 and 3	0,0	-2,3	3578	Kulite
UBA10014	E, over dep.hole 3	0,0	0,0	3575	Kulite
UBA10015	E, over dep.hole 3	0,0	-1,8	3575	Geokon
UBA10016	E, over dep.hole 3	0,3	-2,6	3575	Geokon
UBA10017	E, over dep.hole 3	-0,1	-3,1	3575	Geokon
UBA10018	E, over dep.hole 3	-2,3	0,0	3575	Geokon
UBA10019	E, over dep.hole 3	0,0	0,0	3575	Geokon
UBA10020	F, between dep.hole 3 and 4	0,0	0,0	3572	Kulite
UBA10021	F, between dep.hole 3 and 4	0,0	-2,3	3572	Kulite
UBA10022	In front of plug	0,0	0,0	3565	Kulite
UBA10023	In front of plug	0,1	0,0	3562	Kulite

Table 4-14. Numbering and position of instruments for measuring relative humidity (W) in the backfill.

Type and number	Instrument position			Fabricate	Remark
	Section	x	z		
		m	m	m	
WBA10001	Inner part	0,0	0,0	3589	Wescor
WBA10002	Inner part	0,0	0,0	3592	Wescor
WBA10003	Inner part	0,1	-0,1	3590	Wescor
WBA10004	E, over dep.hole 1	0,3	2,3	3587	Wescor
WBA10005	E, over dep.hole 1	0,0	1,3	3587	Wescor
WBA10006	E, over dep.hole 1	0,0	0,1	3587	Wescor
WBA10007	E, over dep.hole 1	0,1	-0,8	3587	Wescor
WBA10008	E, over dep.hole 1	0,0	-1,7	3587	Wescor
WBA10009	E, over dep.hole 1	-0,1	-2,6	3587	Wescor
WBA10010	E, over dep.hole 1	-0,5	-3,1	3587	Wescor
WBA10011	E, over dep.hole 1	-2,3	-0,1	3587	Wescor
WBA10012	E, over dep.hole 1	-1,3	0,0	3587	Wescor
WBA10013	E, over dep.hole 1	1,3	0,0	3587	Wescor
WBA10014	E, over dep.hole 1	2,3	0,0	3587	Wescor
WBA10015	F, between dep.hole 1 and 2	0,0	1,3	3584	Wescor
WBA10016	F, between dep.hole 1 and 2	0,0	2,3	3584	Wescor
WBA10017	F, between dep.hole 1 and 2	0,0	0,0	3584	Wescor
WBA10018	F, between dep.hole 1 and 2	0,0	-1,3	3584	Wescor
WBA10019	F, between dep.hole 1 and 2	-1,3	0,0	3584	Wescor
WBA10020	F, between dep.hole 1 and 2	1,3	0,0	3584	Wescor
WBA10021	F, between dep.hole 2 and 3	0,0	2,3	3578	Wescor
WBA10022	F, between dep.hole 2 and 3	0,0	1,2	3578	Wescor
WBA10023	F, between dep.hole 2 and 3	0,0	-0,2	3578	Wescor
WBA10024	F, between dep.hole 2 and 3	0,0	-1,2	3578	Wescor
WBA10025	F, between dep.hole 2 and 3	-1,3	0,0	3578	Wescor
WBA10026	F, between dep.hole 2 and 3	1,3	0,0	3578	Wescor
WBA10027	E, over dep.hole 3	0,0	2,5	3575	Wescor
WBA10028	E, over dep.hole 3	0,0	1,3	3575	Wescor
WBA10029	E, over dep.hole 3	0,0	0,0	3575	Wescor
WBA10030	E, over dep.hole 3	0,0	-0,9	3575	Wescor
WBA10031	E, over dep.hole 3	0,0	-1,6	3575	Wescor
WBA10032	E, over dep.hole 3	-0,3	-2,6	3575	Wescor
WBA10033	E, over dep.hole 3	0,1	-3,1	3575	Wescor
WBA10034	E, over dep.hole 3	-2,3	0,0	3575	Wescor
WBA10035	E, over dep.hole 3	-1,3	0,0	3575	Wescor
WBA10036	E, over dep.hole 3	1,3	0,0	3575	Wescor
WBA10037	E, over dep.hole 3	2,3	0,0	3575	Wescor
WBA10038	F, between dep.hole 3 and 4	0,0	2,3	3572	Wescor
WBA10039	F, between dep.hole 3 and 4	0,0	1,2	3572	Wescor
WBA10040	F, between dep.hole 3 and 4	0,0	0,0	3572	Wescor
WBA10041	F, between dep.hole 3 and 4	0,0	-1,3	3572	Wescor
WBA10042	F, between dep.hole 3 and 4	-1,3	0,0	3572	Wescor
WBA10043	F, between dep.hole 3 and 4	1,3	0,0	3572	Wescor
WBA10044	In front of plug	0,0	0,0	3565	Wescor
WBA10045	In front of plug	-0,1	0,0	3562	Wescor

5 Results and comments for Section 1

5.1 General

In this chapter short comments on general trends in the measurements are given. Sensors that are not delivering reliable data or no data at all are noted and comments on the data collection in general are given.

The heating of the canister in hole1 started with an applied constant power of 1800 W at 010917. This date is also marked as start date. The backfilling started 010903 and was finished 011120 and the plug was cast at 011214. In order to simulate the radioactive decay, the power was decreased 20 W one year after start of the first heater. At the beginning of September 2004 the power was decreased with about 30 W to 1710 W in deposition holes 1-4. Table 5-1 shows some important dates for section 1. At the beginning of November 2004 the drainage of the inner part of Section 1 and the drainage trough the outer plug were closed. At the beginning of December 2004 damages were observed on one canister in Section 1 (No 1) and one in Section 2 (No 6) probably due to high water pressure in the buffer and backfill. It was then decided to switch off the power to all canisters. This was done on December 2. The drainage of the tunnel was opened on December 6 and investigations on the damaged canisters were initialized. The power to all the canisters, except for canister 2, was on December 15 switched on. The damages on canister 2 were so severe that it was impossible to apply any power in this canister. The drainage of the tunnel was kept open.

In December 2005, 2006 and 2007 the power to the canisters was reduced with about 30 W. The applied power after the latest reduction is about 1620 W.

Beside the above reported power reductions a change in power was made June 23 2003 due to additional calculations of the power from measurement of the energy. The power of the canisters was adjusted to 1800 W. The most significant change was made for canister 2 (See section 5.4.1 and Appendix 3 page 138).

At present about 246 (excluding water pressure sensors in the rock and the displacement sensors for the canister) out of totally 363 installed sensors are out of order. In Figure 5-1 the numbers of still working sensors in the buffer and the backfill of Section 1 are plotted as function of time from June 2004. The figure shows that the majority of the broken sensors are RH-sensors and thermocouples (in deposition hole 3). The figure also shows that the numbers of broken sensors increased after the closing of the drainage of the tunnel.

Table 5-1. Key dates for section 1.

Activity	Date
Start backfilling	3/9 2001
Start heating canister 1	17/9 2001
Start heating canister 2	24/9 2001
Start heating canister 3	11/10 2001
Start heating canister 4	22/10 2001
Finish backfilling	20/11 2001
Plug casting	14/12 2001
Decreased power (-20 W)	17/9 2002
Decreased power (-40 W)	5/9 2003
Decreased power (-30 W)	8/9 2004
The drainage of tunnel was closed	1/10 2004
The power to all canisters was switched off	2/12 2004
The drainage of the tunnel was opened	6/12 2004
The power to the canisters was switched on	15/12 2004
Decreased power (-30 W)	2/12 2005
A packer installed in the rock was broken	18/5 2006
Decreased power (-30 W)	21/12 2006
Decreased power (-30 W)	11/12 2007

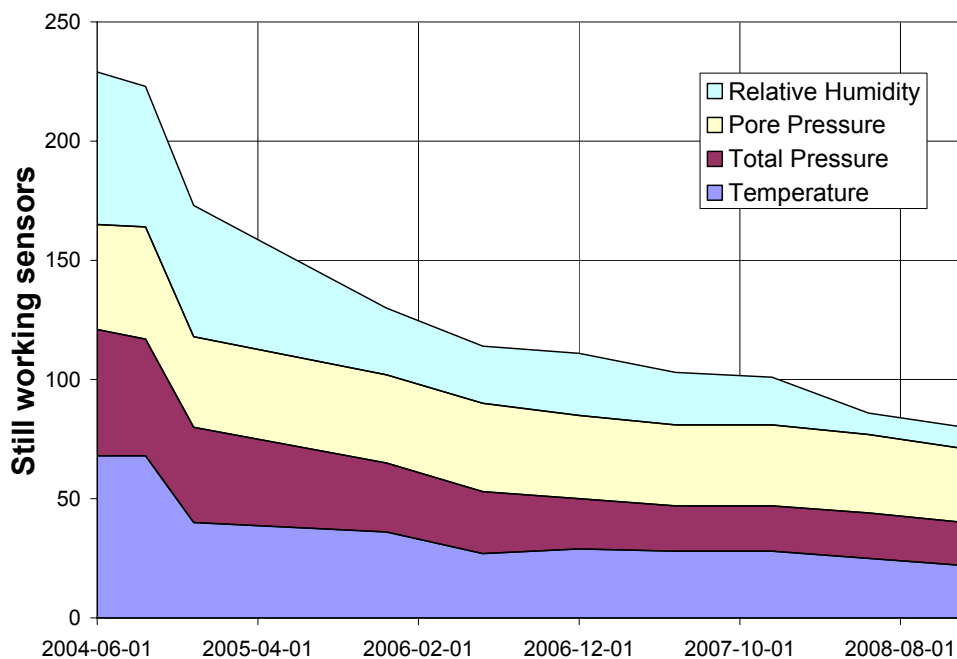

Figure 5-1. The number of still working sensors placed in the buffer and backfill in Section 1 as function of time. The coloured fields are representing the four types of installed sensors.

The measured processes were slow up to about 20 days after the drainage of the tunnel was closed. Very small changes of the measured parameters occurred up to that date. After that the readings from some of the total and pore pressure sensors placed in the buffer reacted strongly (quick increase in pressure). Also the total and pore pressure sensors placed in the backfill recorded high pressures caused by the closing of the drainage. After the reopening of the drainage of the tunnel, both the pore pressures and the total pressures in the backfill were stabilized on almost the same level as before the closing of the drainage. At around day 1670 both the total pressure sensors and the pore pressure sensors are measuring an increase in pressure. This is caused by a failure in one packer placed in the rock at the inner part of the tunnel causing an increase in out flow of water from the inner section from about 1.5 l/min to more than 9 l/min.

So far hole 1 has been strongly wetted and a very slowly wetting is observed in hole 3. A slow but obvious wetting of the backfill is noted until about 20 days after the closing of the drainage. After that a strong increase of the wetting rate was monitored by several psychrometers. The measurement of the temperature on the canister surface with the optical system has stopped functioning.

5.2 Deposition hole 1

5.2.1 Total pressure

Geokon (App. 1\pages 93-95)

The measured pressure range is from 0 to 8.5 MPa. The highest pressure is indicated from the peripheral sensors in the bottom block (C1). Four sensors in block R5 and block R10 yielded a high increase in total pressure when the drainage of the tunnel was closed. Most of the sensors yielded a drop in pressure when the heaters were switched off and the drainage of the tunnel was opened again and an increase in pressure when the heaters were switched on again. One sensor placed at the top of block C3 was measuring a pressure of about 1.3 MPa at the end of this measuring period.

Fifteen sensors are out of order.

Kulite (App. 1\page 96)

The highest pressure 7 MPa is indicated from the peripheral sensor (PBU 10012) in block R5. Three of the installed sensors indicated a rapid increase in pressure when the drainage of the tunnel was closed followed by a drop in pressure when the power was switched off and the drainage was reopened. After the power was switched on the pressure increased to the same level as before the closing of the drainage.

Two sensors were not installed and five of the installed sensors are out of order.

5.2.2 Relative humidity

Vaisala (App. 1\pages 97-100)

Since temperature is also measured with all relative humidity sensors, the diagrams include those measured temperatures. The temperature measurements start at about 16 degrees while the RH measurements start at about 70 %RH.

The relative humidity measured in the buffer has not changed very much during the last 6 months, except for the sensors placed above the canister (in Cylinder 3 and 4) which are indicating a slowly wetting. The sensors have not reached 100 RH. The temperature measurements were effected when the power to the heaters was switched off but reached the same levels as before when the power was switched on again. A slow decrease in temperature is measured by all of the still working sensors

Sixteen sensors are out of order, most of them due to high water saturation of the buffer.

Rotronic (App. 1\pages 101-105)

All Rotronic sensors placed between the canister and the rock measured RH higher than 90% within 200 days after the start of the test. Two of the sensors placed in the central part of block C1 indicated a drying of the bentonite (decreasing in RH from about 75%) up to the time when they stopped working (after about 1000 days).

All of the installed sensors have stopped giving reliable RH values, most of them due to high water saturation of the buffer. Many of the temperature sensors are still working.

5.2.3 Pore water pressure

Geokon (App. 1\page 106)

The highest pressures 500-1450 kPa are measured near the canister surface in block R5 (UBU10005) and in the periphery of block R5 (UBU10010). Two sensors in block C1 are also recording an increasing pressure (UBU10002, UBU10003) while the rest of the sensors are measuring very low pressures.

Two sensors are out of order.

Kulite (App. 1\page 107)

Rather high water pressures have been measured by three sensors located in block R5 (1200 – 3500 kPa). One sensor placed in the outer slot started to react about 50 days after the start of the measurement. The pore pressure measured with two of the sensors reacted strongly during the period when the drainage of the tunnel was closed and during the period when the power to the canister was switched off. The sensors measured an increase of the pressure with about 100 kPa after the middle of May 2007. This change in pressure is probably cause by the preparation work done for a new tunnel near by the Prototype tunnel.

Three sensors are out of order.

5.2.4 Temperature in the buffer (App. 1\pages 108-114)

The measured temperature after the power to the canister was switched on again ranges from 28.0 °C (in the periphery of the upper bentonite cylinder C4) to 70.0 °C in block R5 close to the canister. The highest temperature gradient measured in the buffer is 0.57 °C /cm (block R5).

Twenty-nine sensors are out of order.

The temperature in the buffer is also measured with the Geokon sensors (from day 1350). The maximum temperature recorded with these sensors is about 60 °C at the end of this measuring period (PBU10002 placed in the centre of block C1 close to the canister).

5.2.5 Canister power in dep. hole 1 (App. 1\page 118)

The power of the canister in whole 1 was kept constant during one year at 1800 W since the start 010917. After one year the power was decreased with about 20 W. After another year the power was decreased with about 40 W. The next reduction of power was made at the beginning of September year 2004 (about 30 W). The power of the canister in hole 1 was about 1710 W after this reduction. During the period between December 6 and December 15 2004 the power to the canister was switched off. After that period the power was adjusted to about 1710 W again. At the beginning of December 2005, 2006 and 2007 the power was decreased with 30 W. After the latest reduction the power is now about 1620 W.

5.2.6 Temperature on the canister surface (App. 1\pages 119-120)

The first diagram shows the maximum temperature, measured with the optical cables placed on the surface of the canister, plotted as function of time. The maximum measured temperature on the canister surface is about 75 °C. With no damages on the optical cables this plot should have four curves. Only one curve with relevant values is presented here up to December 24 which indicates that the optical cables are damaged. The second diagram shows the distribution of the temperature along the optical cables at December 1 2004. The length of the cables on the canister surface is about 20 m. The variation of a few degrees is caused by the difference in temperature in the centre and ends of the canister. At December 15 2004 the optical system for measuring the temperature on this canister stopped functioning.

5.3 Deposition hole 3

5.3.1 Total pressure

Geokon (App. 2\pages 123-125)

Most of the sensors placed in block C1 and block R10 yielded an increase in total pressure when the drainage of the tunnel was closed.

The total pressures measured in this deposition hole are significantly lower than those measured in deposition hole 1. The maximum pressure registered so far is 4 MPa (PBU30023). This value was obtained when the drainage was closed. The sensor is placed in block R10. Four out of 16 sensors have measured a pressure higher than 500 kPa.

Twelve sensors are out of order.

Kulite (App. 2\pages 126-127)

The highest pressure, 1.8 MPa, is indicated from the peripheral placed sensors in block R10. Also one sensor placed in block R5 are measuring a pressure higher than 1.5 MPa. The sudden change in pressure that occurred after about 180 days was probably caused by early data logger problems.

Ten sensors are out of order

5.3.2 Relative humidity

Vaisala (App. 2\pages 128-131)

A significant drying of the bentonite close to the top of the canister was observed by the two sensors WBU30022 and WBU30023. After the closing of the drainage both sensors indicated an instant and significant increasing in relative humidity. The still working sensor (WBU30022) is measuring a slowly increasing in humidity, implying a wetting of the buffer close to the canister lid.

An increased wetting of the bentonite can be observed by sensors place in block R10 between the canister and the rock. One sensor placed in block R5 showed an increase in relative humidity from about 70% to 82% after the closing of the drainage.

Two sensors (WBU30019 and WBU30020) placed in block R5 measured a decrease in relative humidity (indicating a drying of the buffer) after the power was switched on again. During this measuring period the still working sensor (WBU30020) is measuring a slowly increase in relative humidity.

Seventeen sensors are out of order.

Rotronic (App. 2\pages 132-136)

All Rotronic sensors in hole 3 have failed or increased the measured RH to 100%. The reason for this is unclear. Since there are no other signs of strong wetting, malfunction are more probable than strong wetting. One sensor (WBU30016) placed close to the canister in block R5 was indicating a drying of the bentonite until it failed.

Sixteen sensors are at present out of order.

5.3.3 Pore water pressure

Geokon (App. 2\page 137)

All sensors yield very low pressures except for one sensor below the canister that yields a sudden increase to 220 kPa around day 300.

Kulite (App. 2\page 138)

UBU30004 yielded a maximum pressure of 440 kPa. This sensor is placed near the rock surface at the bottom of the deposition hole. The rest of the sensors yield very low pressures.

5.3.4 Temperature in the buffer (App. 2\pages 139-145 and 148)

The measured temperature ranges from 38 °C (in the periphery of the upper bentonite cylinder C4) to a temperature of 83.2 °C in the centre close to the canister. These measurements are from the period just before the power to the canisters were switched off. The highest temperature gradient measured with the sensors is 0.59 °C/cm (block R5). There have appeared some problems with some data scan units, which explains the noise in some curves.

30 sensors are out of order.

The temperature in the buffer is also measured with the Geokon sensors (from day 1350). The maximum temperature recorded at the end of this measuring period with these sensors is about 78 °C (UBU30009 placed in block R5 close to the canister). The maximum temperature gradient determined at mid height of the canister and at the end of this measuring period is 0.52 °C/cm.

5.3.5 Canister power (App. 2\page 149)

The power of the canister in hole 3 was kept constant at 1800 W from the start 011011 until 020917, when the power was decreased with about 20 W. The power has been stepwise decreased according to Table 5-1. During the period between December 6 and December 15 the power of all canisters was switched off. After that period the power was adjusted to about 1710 W. At the beginning of December 2005, 2006 and 2007 the power was decreased with 30 W. After the latest reduction the power is now about 1620 W.

5.3.6 Temperature on the canister surface (App. 2\pages 150-151)

The first diagram shows the maximum temperature plotted as a function of time. The maximum measured temperature on the canister surface was about 100 °C just before the power to the canisters was switched off. The temperature recovered, but only to about 93 °C after the power was switched on again and after that a slightly decrease in temperature was measured until the sensor stopped functioning at the end of August 2005. The second diagram shows the distribution of the temperature along the cables. See also chapter 5.2.6.

5.4 Deposition hole 2

5.4.1 Canister power (App. 3\page 156)

The power of the canister in hole 2 was kept constant at 1800 W from the start 010924 until 020917, when the power was decreased with about 20 W. After two years (September 2003) the power was decreased with about 40 W to 1740 W. The interruption in the curve between days 409 and 456 is caused by data collection problems. At the beginning of September 2004 the power was decreased with about 40 W to 1710 W. Since permanent damages on the heaters in the canister were observed on December 1 2 004 the power to this canister has been switched off and not been restarted.

5.4.2 Temperature on the canister surface (App. 3\pages 157-158)

See chapter 5.2.6. The maximum measured temperature on the canister surface was just before the power was switched off about 96 °C. The reason for the unexpected increase in temperature after 450 days is the difficulties with the measurement of the power (see chapter 5.2.5). The actual power at that time was probably higher than 1800 W. After the power was switched off the temperature on the canister surface was stabilized on about 30 °C. The sensor stopped giving reliable data at the beginning of June 2005.

5.5 Deposition hole 4

5.5.1 Canister power (App. 3\page 161)

The power of the canister in hole 3 was kept constant at 1800 W from the start 011011 until 020917, when the power was decreased with about 20 W. Some initial problems with the control system for the power have been overcome. The power has been stepwise decreased according to Table 5-1. During the period between December 6 and December 15 the power of all canisters was switched off. After that period the power was adjusted to about 1710 W. At the beginning of December 2005, 2006 and 2007 the power was decreased with 30 W. After the latest reduction the power is now about 1620 W.

5.5.2 Temperature on the canister surface (App. 3\pages 162-163)

See chapter 5.2.6. The maximum measured temperature on the canister surface after the power was switched on again was 88 °C. The sensor stopped giving reliable data at the beginning of April 2005.

5.6 Backfill in Section1

5.6.1 Total pressure in the backfill

Geokon (App. 4\pages 167-168)

All these sensors yielded high increase in total pressure in connection with closing of the tunnel drainage. The maximum measured pressure was about 2.5 MPa. After the opening of the drainage the total pressure was stabilized on the same level as before the closing of the drainage (maximum pressure about 0.2 MPa). At around the 20th of April 2006, a packer placed in a borehole in Section I of the tunnel started to leak resulting in an increase of water drained out from the inner section from about 1.5 l/min to about 9 l/min. The damaged packer caused also an increase in the measured total pressure of about 300 kPa (around day 1660). At the beginning of April 2007 some of the sensors are indicating an increase in the measured pressure. The change in the measured pressures is probably related to the work with the excavation of a new tunnel near by the Prototype-tunnel which was initialized at that time. The measured total pressures at the end of this measuring period vary between 400 – 900 kPa at the end of this measuring period.

Two sensors are out of order.

Kulite (App.4 \pages 169-170)

These measurements yielded rather small increase in total pressure until the drainage of the tunnel was closed. The maximum pressure recorded is with PBA10013, about 350 kPa. The sensor stopped functioning during a period of about 100 day after the rapid increase in pressure when the tunnel drainage was closed. Sensor PBA10013 is placed 1.7 m above the bentonite surface in hole 3.

All sensors are out of order.

5.6.2 Suction in the backfill (App. 4\pages 171-177)

The suction in the backfill is measured with Wescor psychrometers. The steady but slow wetting (decrease in suction) observed in about 50% of the sensors continues. 7 sensors close to the roof and walls of the tunnel and one sensor just above the buffer in hole 1 indicate fast wetting that has gone close to water saturation (less than 1000 kPa suction). Also the sensor placed just inside the plug has reached a suction value that indicates saturation. In connection with the closing of the drainage, a very rapid decrease in suction was recorded by the installed psychrometers. Six of these sensors placed in the central part of the tunnel section yielded an increase in suction, after the reopening of the drainage, to the same level as before the closing. Seven of the sensors measured a decrease in suction after the packer was damaged.

Many of these sensors have stopped giving reliable values due to high water saturation of the backfill. None of the still working sensors are measuring suction values higher than 800 kPa.

5.6.3 Pore water pressure in the backfill

Geokon (App. 4\pages 178-179)

All these sensors yielded high increase in pore pressure when the drainage of the tunnel was closed. Many of the sensors recorded pressures up to 2.5 MPa. After the opening of the drainage the pore pressure was stabilized at low pressures (below 0.1 MPa). Also these sensors reacted when the packer was broken by measuring an increase in pore pressure of about 200 kPa. At the beginning of April 2007 some of the sensors are indicating an increase in the measured pressure. The change in the measure pressures is probably related to the work with the excavation of a new tunnel near by the Prototype-tunnel which was initialized at that time. The measured pore pressures vary between 500 – 700 kPa at the end of this measuring period.

Kulite (App. 4\pages 180-181)

Also some of these sensors recorded very high water pressure after the closing of the drainage. The still functioning sensors measured an increase in pore pressure of about 200 kPa at the time when the packer installed in the rock was broken. The sensors reacted also when the excavation of the nearby tunnel was initialized. Eight sensors are out of order.

5.6.4 Temperature in the backfill (App. 4\pages 182-186)

The measured temperature in the backfill over the whole test period ranges from 18 to 35 °C. The highest temperature was as expected measured above the buffer in hole 3 just before the drainage was opened. Also these sensors reacted when the packer was broken (a decrease in temperature). The measured temperatures at the end of this measuring period vary between 17 and 30 °C.

5.7 Temperature in the rock

5.7.1 Near hole 1 (App. 1\pages 115-117)

The maximum temperature measured in the rock is 38.6 °C. This temperature was measured with the thermocouple TROA1030 located 2.038 m from the centre of the canister in deposition hole 1. The temperature in the rock close to the deposition hole decreased when the power to the canisters was switched off but increased again when the power was switched on to a temperature about 1 °C lower than before the power was switched off. The temperature is continuing to drop and the maximum temperature at the end of this measuring period is about 35 °C.

5.7.2 Near hole 2 (App. 3\page 155)

The maximum temperature in the rock (46.8 °C) was measured by TROA1820 located 2.490 m from the centre of the canister in deposition hole 2 just before the power to the canisters was switched off. Since no power is applied to this canister anymore the temperature in the rock around the deposition hole is continuing to decrease and the maximum temperature at the end of this measuring period is about 32 °C.

5.7.3 Near hole 3 (App. 2\pages 146-147)

The maximum temperature in the rock (48.8 °C) was measured by TROA2120 located 1.967 m from the centre of the canister in deposition hole 3 just before the power to the canisters was switched off. Although the power was switched on again the temperature around the deposition hole is continuing to drop. This is most obvious for the sensors installed in the direction towards deposition hole 2. The maximum temperature measured temperature at the end of this measuring period is about 40 °C.

5.7.4 Near hole 4 (App. 3\page 160)

The maximum temperature in the rock (46.5 °C) is measured by TROA3030 located 2.034 m from the centre of the canister in deposition hole 4. Also for this deposition hole there was a drop in the temperature in the rock when the power was switched off. After the power was switched on again the temperature in the rock increased to almost the same level as before the power was switched off and has been remained relatively constant since then.

5.8 Analyze of data from Section 1

5.8.1 Deposition hole 1

Before the drainage of the tunnel was closed and the power of the canister was switched off the saturation of the buffer at mid height of the canister in block R5 was considered (indicated both by the relative humidity sensors and total pressure sensors) to be high even close to the canister (PBU10015). Also installed pore pressure sensors placed in block R5 (e.g. UBU 10007) are measuring high pressures close to the canister which also is indicating that the bentonite is saturated. This was not changed when the drainage was opened and the power of the canister was switched on again. The degree of saturation in the solid blocks both under (Block C1) and above the canister (Blocks C2-C4) is much lower. However the degree of saturation interpretable from measurements of relative humidity, swelling pressure and pore pressure is increasing with time. This trend is continuing with the same rate after the drainage was opened and the power was switched on.

In Figure 5-2 the temperature in the buffer is plotted as function of the radius from the centre of the deposition hole. The measurements are made with different type of sensors in block R5 (at mid height of the canister). A straight line is fitted to the measured values. The temperature gradient is determined from the fitted line in the figure. This gradient together with the temperature on the canister surface and the temperature in the buffer close to the outer radius of the ring shaped block ($r = 785 \text{ mm}$) are plotted as function of time in Figure 5-4. The shaded part of the plot represents the time when the power to the canister was switched off at the beginning of December 2004. The plot shows that the temperature after this is somewhat lower than before, probably due to the fact that no power is applied to canister 2 after December 2 2004. However the temperature gradient over the buffer is similar before and after the switch on/off the power of the canisters. The determination of the gradient was made up to the beginning of December 2005. After that the number of still working sensors are too few, to be able to determine the temperature gradient.

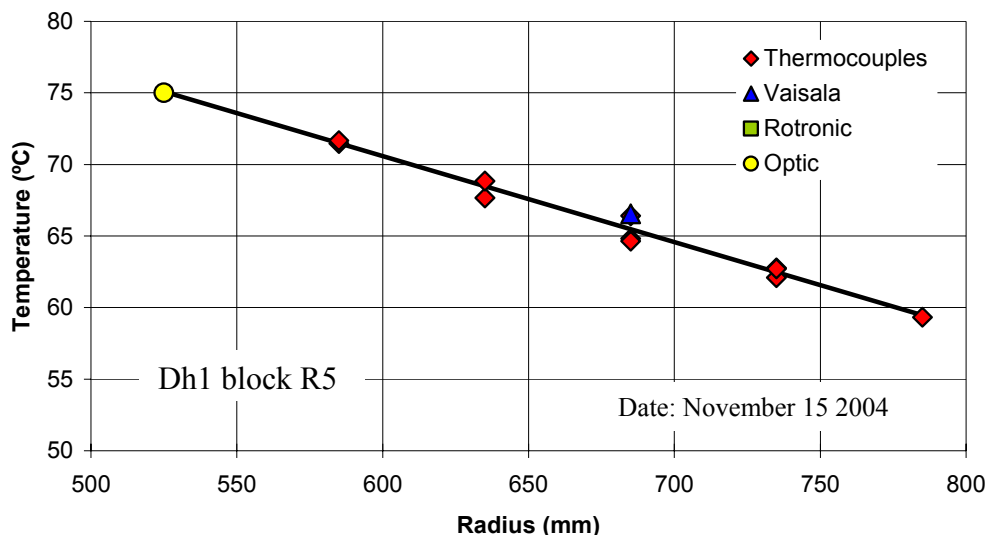

Figure 5-2. The temperature in block R5 in Dh 1 as function of radius from the centre of the deposition hole on November 15, 2004.

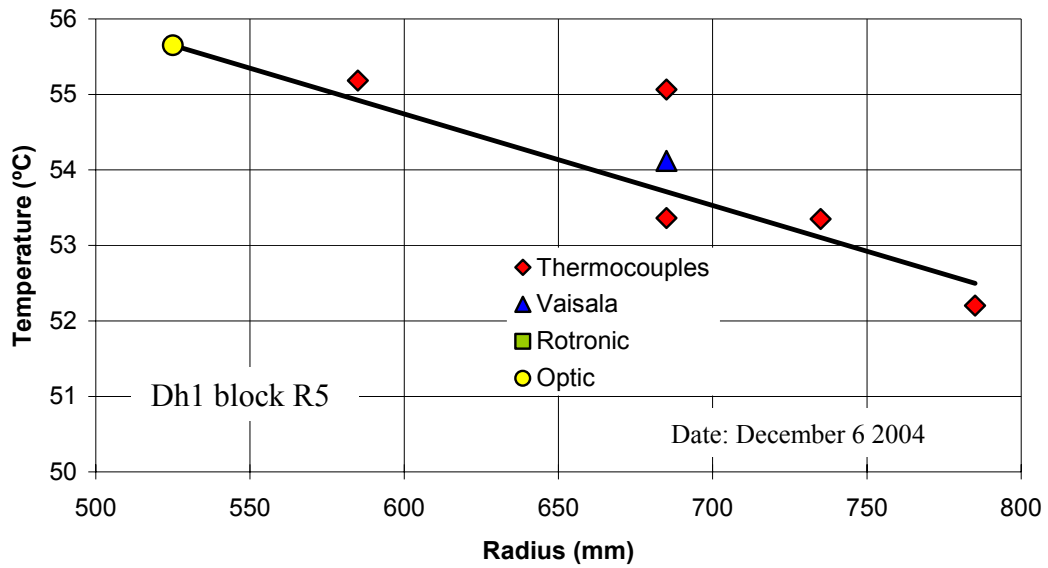

Figure 5-3. The temperature in block R5 in Dh 1 as function of radius from the centre of the deposition hole on December 6, 2004.

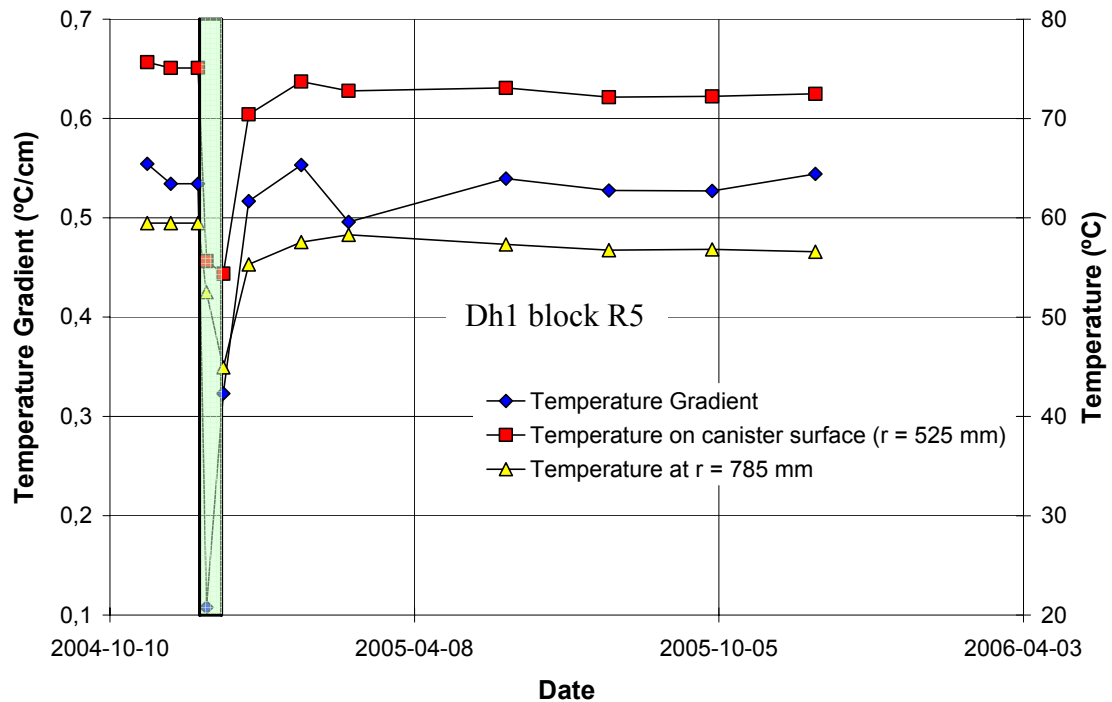

Figure 5-4. The temperature and temperature gradient plotted as function the date in deposition hole 1 block R5.

5.8.2 Deposition hole 3

The saturation of the buffer, as an average, indicated by both RH-transducers and total pressure transducers was before the closing of the drainage much lower compared to the buffer in deposition hole 1, although some total pressure sensors placed above and under the canister indicated rather high total pressures. When the drainage was closed those total pressure sensors which before had indicated high total pressure reacted with a rapid increase in pressure while the rest of the transducers did not react at all. When the drainage was opened again and the power to the canisters was switched off there was a decrease in the pressure. For most of the transducers the pressure went down to the same level as before the closing of the drainage. One RH sensor placed in block R5 at a radius of 785 mm reacted with a significant increase in RH (from 70% to 82%) when the drainage was closed. The RH was maintained on the higher level even after the opening of the drainage. Also some transducers placed in the buffer but close the canister top reacted with an increase in RH of about 5%. These transducers had before the closing of the drainage indicated a drying of the buffer. The rest of the RH transducers reacted very little at the closing/opening of the drainage. The buffer is today far from saturated (indicated both by RH-sensors, total pressure sensors and pore pressure sensors).

In Figure 5-5 the temperature in deposition hole 3 is plotted as function of the radial distance from the centre of the deposition hole. Compared the corresponding plot for deposition hole 1 this plot shows a significant drop in temperature between the surface of the canister and the buffer (inner diameter of the ring). This indicates that the initial slot (of about 10 mm) between the canister and the buffer was still open.

The temperature gradient over the inner slot together with the temperature on the canister and the temperature on the inner radius of the ring shaped block are plotted as function of time in Figure 5-6. The shaded part of the plot represents the time when the power to canisters was switched off. Immediately after the power was switched off the temperature gradient increased which indicate that the slot was isolating the canister resulting in a much faster drop in temperature of the buffer than the canister surface. When the power was switched on again the temperature gradient over the slot reached the same level as before the closing of the drainage indicating an open slot between the canister and the buffer. The figure also shows that the gradient is decreasing with time which might be an indication that the gap is getting smaller. The sensors for measuring the temperature on the canister surface stopped functioning of August 2005. The temperature gradient over the inner slot could not be calculated after that date.

The temperature gradient over the buffer is plotted in Figure 5-7 together with the temperature on the inner surface of the block and the temperature at the radius of $r = 785$ mm. After the power was switched on again also this gradient stabilized on the same level as before the power was switched off.

A conclusion of the analyses is that even though the pressure in the backfill and in the surrounding rock was high (more than 2 MPa) when the drainage was closed, water did not enter the inner slot between the buffer and the canister. The fact that no water pressure acted directly on the canister surface can also explain the large vertical displacement of the canister measured when the drainage was closed (see Figure 5-8). If the increased pore pressure (2.5 MPa) would act directly on the canister surface the deformation should be much smaller than what was measured. The measured deformation was probably caused by large deformations of the solid bentonite block below the canister.

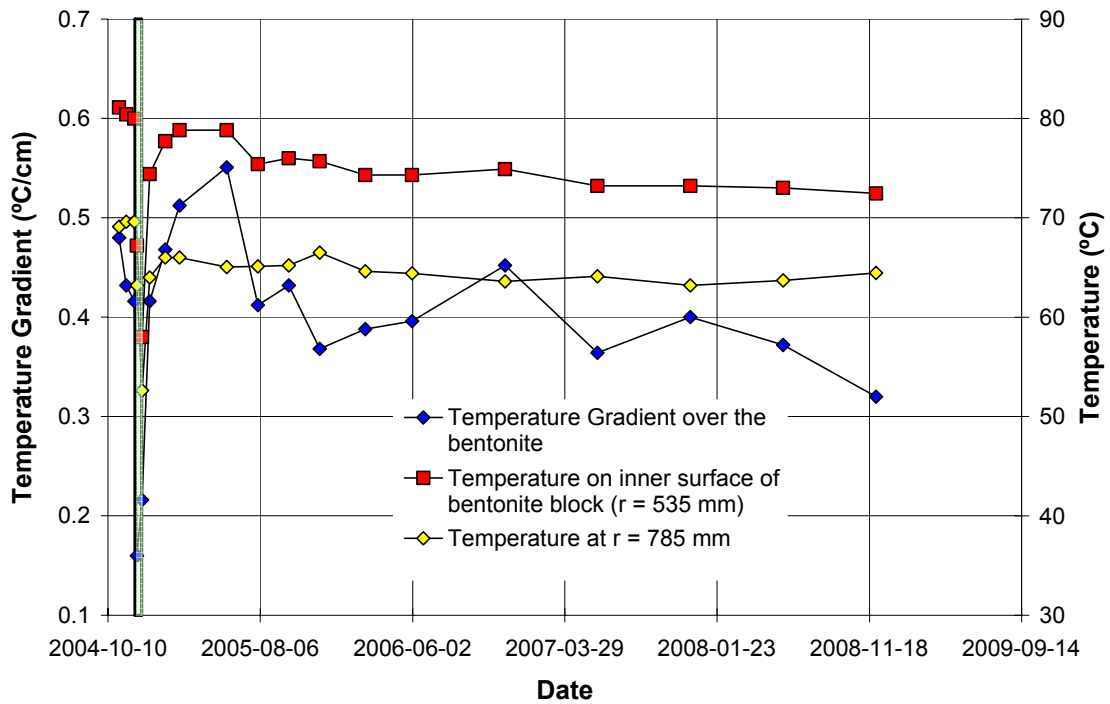

Figure 5-7. The temperature and temperature gradient over the buffer plotted as function the date in deposition hole 3 block R5.

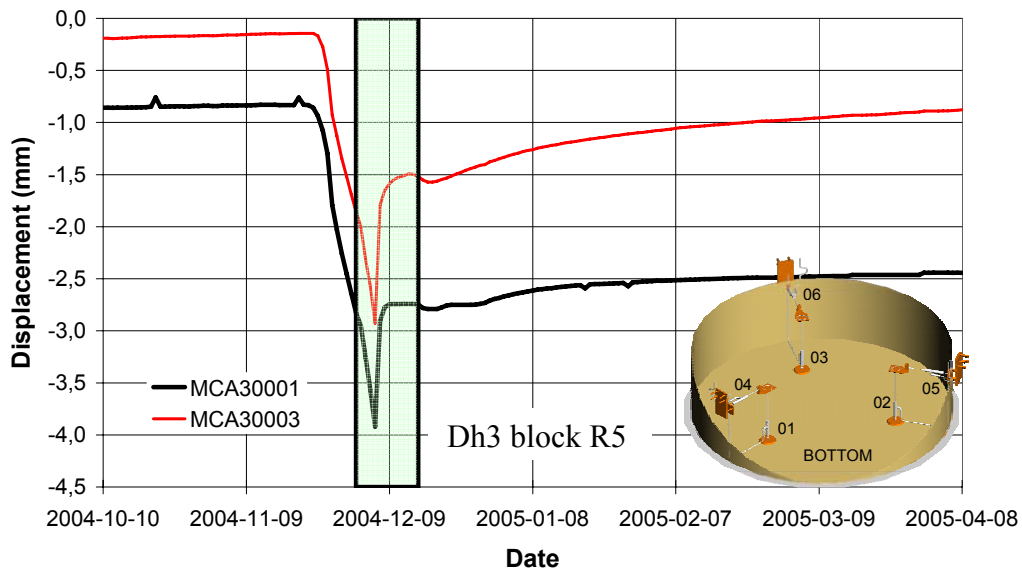

Figure 5-8. Vertical displacement of the canister in Dh 3. Negative sign on the displacement means that the canister is moving downwards.

5.8.3 Backfill

The pore pressure in the backfill increased fast from a low level when the drainage of the tunnel was closed. This affected the rate in which the backfill was saturated measured both with soil psychrometers and with resistivity measurements made by GRS. After the drainage was reopened the pore pressure stabilized on the same level as before it was close. The saturation rate (measured with both psychrometers and resistivity measurements) decreased to the same rate as before the closing of the drainage for most of the sensors.

When a packer placed in a borehole in Section I was broken (at the middle of April 2006) the pressure in the backfill (both total pressure and pore pressure) increased with about 300 kPa.

An increase of the total pressure and the pore pressure can also be observed around day 2040 (corresponding to the date 2007-04-19). The increase in pressure is probably related to the work with the excavation of a new tunnel nearby the Prototype-tunnel which was initialized at that time. The pore pressure and total pressure are continuing to increase and the total pressure has at the end of this measuring period reach a maximum of about 900 kPa.

The change in pressure affected also the measured suction values (measured with soil psychrometers). Eight of the sensors measured a decrease in suction of about 500 kPa due to the broken packer. The measured suction with one still working sensors at the end of the measuring period is less than 800 kPa which is indicating that the backfill is saturated.

The outflow from the inner section of the Prototype tunnel as function of time is shown in Figure 5-9. The figure is showing that the outflow from Section I increased from about 1.8 l/min to about 9 l/min when the installed packer was broken. The large scatter and the increase in the outflow starting at the beginning of summer 2007 are probably caused by the work with the new tunnel placed close to the Prototype tunnel.

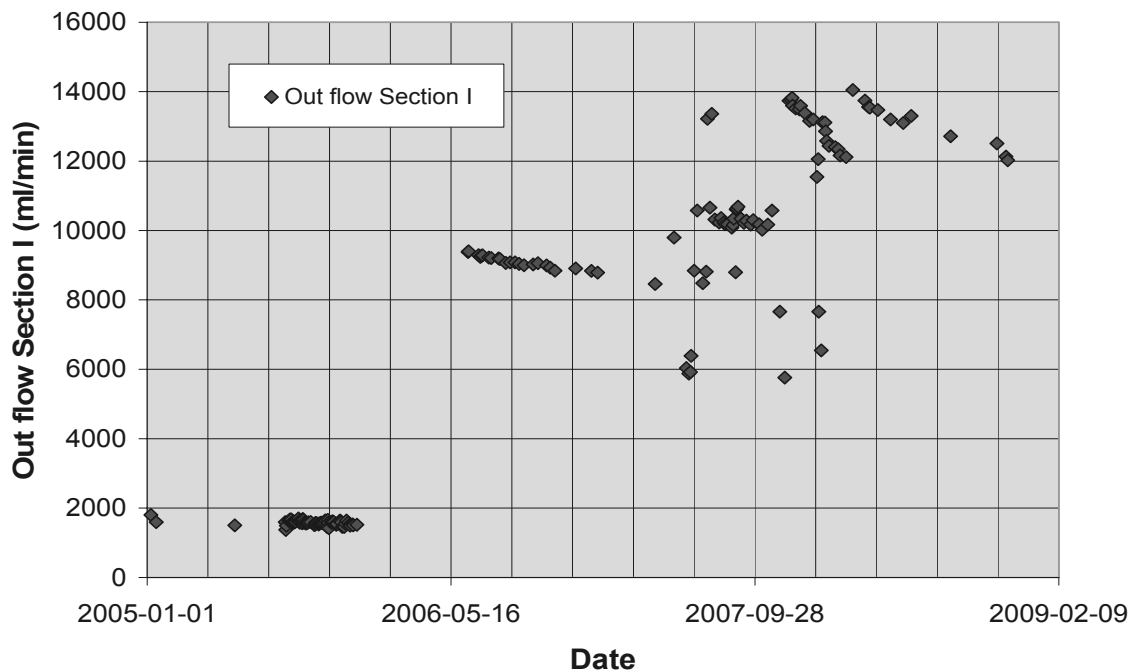

Figure 5-9. The measured outflow from the inner section of the Prototype tunnel.

6 Location of instruments in Section 2

6.1 Strategy for describing the position of each device in the bentonite and rock in and around the deposition holes

The deposition holes in Section 2 are termed DA3551G01 and DA3545G01, hole number 5 and 6 respectively according to Figure 1-1.

Deposition hole 5 has been instrumented in the same way as the two inner deposition holes, 1 and 3 i.e. measurements have been done in four vertical sections A, B, C and D according to Figure 4-1. (See chapter 4-1)

Deposition hole 6 has, however, been instrumented according to another strategy. The instruments have been placed in eight directions, where four directions are represented in each instrumented block, see Figure 6-1.

Direction A and C are placed in the tunnels axial direction with A headed against the end of the tunnel i.e. almost to the West, see Figure 2-1.

Every instrument placed in the buffer is named with a unique name consisting of 1 letter describing the type of measurement, 1 letter describing where the measurement takes place (buffer, rock), 1 figure denoting the deposition hole (5-6) and 2 figures specifying the instrument according to separate lists (see Table 6-1 to 6-11). Every instrument position is then described with three coordinates according to Figure 2-1.

The bentonite blocks are called cylinders and rings. The cylinders are numbered C1-C4 and the rings R1-R10 respectively, see Figure 4-1.

Thermocouples in the rock are placed on 3 levels in each deposition hole (bottom, 3 m and 6 m level). Thermocouples are placed in the bottom of the deposition holes in a vertical hole at the centre of the deposition hole. On level 3 m and 6 m the thermocouples are placed in two vertical directions perpendicular to each other.

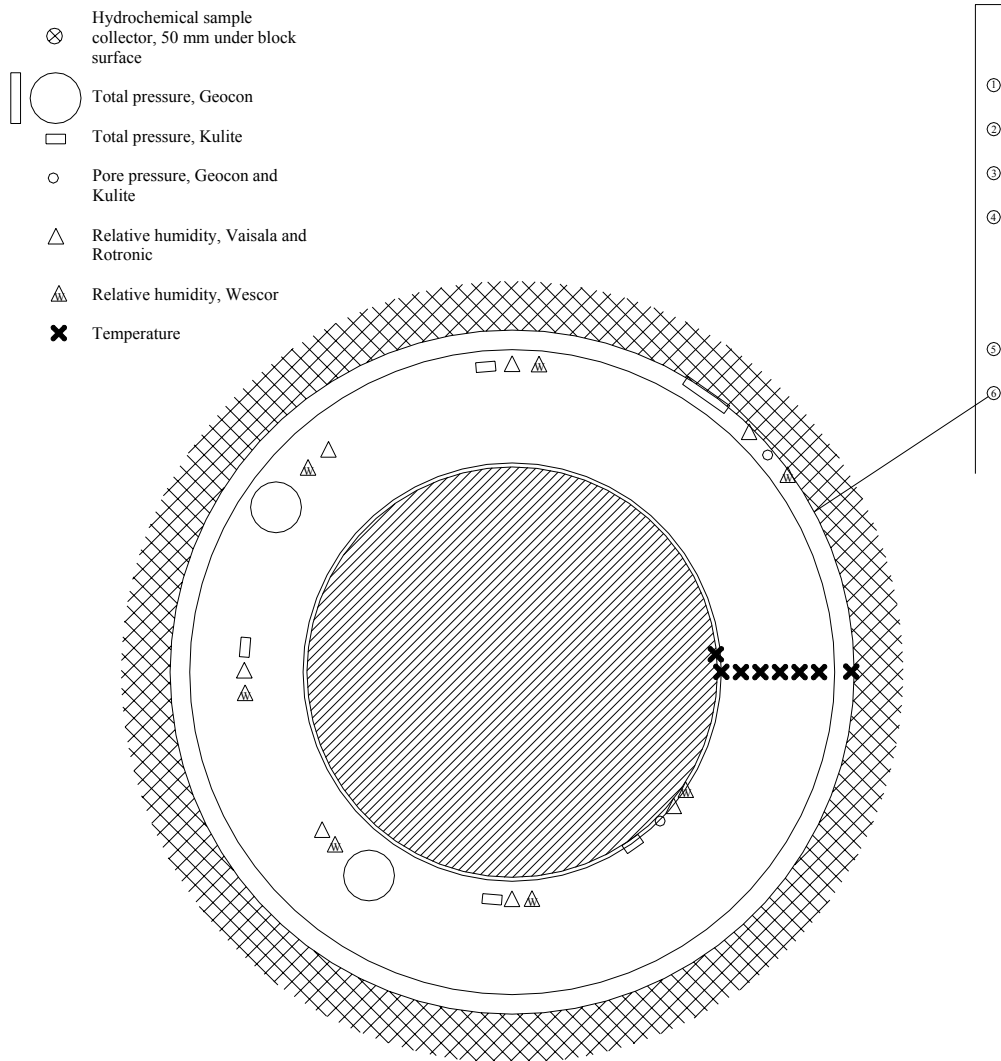

Figure 6-1. Schematic view over the instruments positions in deposition hole 6. The instruments are placed in eight vertical sections, where four sections are represented in each instrumented block.

6.2 Position of each instrument in the bentonite in hole 5 (DA3551G01)

The instruments are located according to the same system as those in hole 1 and hole 3.

The positions of each instrument are described in Tables 6-1 to 6-4. These tables have been updated since the last data report (Sensors data report No 7).

The positions of 10 Wescor psychrometer sensors were determined after inflow measurement on the wall of the deposition hole. The position of these sensors are described in Table 6-5

Table 6-1. Numbering and position of instruments for measuring temperature (T) in the buffer in hole 5.

Typ and number	Block	Instrument position in block			Z m	Fabricate	Remark
		Direction	α degree	r m			
TB501	Cyl. 1	Center	270	0,050	0,080	Pentronic	
TB502	Cyl. 1	Center	270	0,060	0,250	Pentronic	
TB503	Cyl. 1	Center	270	0,070	0,450	Pentronic	
TB504	Cyl. 1	A	355	0,525	0,450	Pentronic	On canister
TB505	Cyl. 1	A	355	0,685	0,450	Pentronic	
TB506	Cyl. 1	B	85	0,685	0,450	Pentronic	
TB507	Cyl. 1	C	175	0,685	0,450	Pentronic	
TB508	Cyl. 1	D	270	0,585	0,450	Pentronic	
TB509	Cyl. 1	D	270	0,685	0,450	Pentronic	
TB510	Cyl. 1	D	270	0,785	0,450	Pentronic	
TB511	Ring 5	A	0	0,525	2,950	Pentronic	On canister
TB512	Ring 5	A	0	0,685	2,986	Pentronic	
TB513	Ring 5	B	85	0,585	2,986	Pentronic	
TB514	Ring 5	B	85	0,685	2,986	Pentronic	
TB515	Ring 5	B	85	0,785	2,986	Pentronic	
TB516	Ring 5	C	175	0,585	2,986	Pentronic	
TB517	Ring 5	C	175	0,685	2,986	Pentronic	
TB518	Ring 5	C	175	0,735	2,986	Pentronic	
TB519	Ring 5	D	270	0,585	2,986	Pentronic	
TB520	Ring 5	D	270	0,635	2,986	Pentronic	
TB521	Ring 5	D	270	0,685	2,986	Pentronic	
TB522	Ring 5	D	270	0,735	2,986	Pentronic	
TB523	Ring 5	D	270	0,785	2,986	Pentronic	
TB524	Ring 10	A	0	0,525	5,150	Pentronic	On canister
TB525	Ring 10	A	0	0,685	5,543	Pentronic	
TB526	Ring 10	D	270	0,585	5,543	Pentronic	
TB527	Ring 10	D	270	0,685	5,543	Pentronic	
TB528	Ring 10	D	270	0,785	5,543	Pentronic	
TB529	Cyl. 3	A	0	0,785	6,353	Pentronic	
TB530	Cyl. 3	B	95	0,585	6,353	Pentronic	
TB531	Cyl. 3	C	185	0,585	6,353	Pentronic	
TB532	Cyl. 4	A	0	0,785	7,060	Pentronic	

Table 6-2. Numbering and position of instruments for measuring total pressure (P) in the buffer in hole 5.

Typ and number	Block	Instrument position in block				Fabricate	Remark
		Direction	α degree	r m	Z m		
PB501	Cyl. 1	Center	0	0,000	0,000	Geokon	Bottom
PB502	Cyl. 1	Center	0	0,100	0,500	Geokon	
PB503	Cyl. 1	A	5	0,585	0,340	Kulite	Vertical
PB504	Cyl. 1	A	5	0,685	0,340	Kulite	Vertical
PB505	Cyl. 1	A	5	0,785	0,340	Kulite	Vertical
PB506	Cyl. 1	B	95	0,635	0,500	Geokon	
PB507	Cyl. 1	B	105	0,735	0,500	Geokon	
PB508	Cyl. 1	C	185	0,635	0,500	Geokon	
PB509	Cyl. 1	C	195	0,735	0,500	Geokon	
PB510	Ring 5	A	10	0,535	2,876	Kulite	In the slot
PB511	Ring 5	A	10	0,685	3,036	Geokon	
PB512	Ring 5	A	5	0,825	2,876	Kulite	In the slot
PB513	Ring 5	B	95	0,635	3,036	Geokon	
PB514	Ring 5	B	105	0,785	3,036	Geokon	
PB515	Ring 5	C	190	0,635	3,036	Geokon	
PB516	Ring 5	C	190	0,825	2,876	Kulite	In the slot
PB517	Ring 10	Center	0	0,050	5,593	Geokon	
PB518	Ring 10	A	10	0,585	5,433	Kulite	Vertical
PB519	Ring 10	A	10	0,685	5,433	Kulite	Vertical
PB520	Ring 10	A	10	0,785	5,433	Kulite	Vertical
PB521	Ring 10	B	95	0,635	5,593	Geokon	
PB522	Ring 10	B	105	0,735	5,593	Geokon	
PB523	Ring 10	C	180	0,635	5,593	Geokon	
PB524	Ring 10	C	190	0,735	5,593	Geokon	
PB525	Cyl. 3	Center	0	0,100	6,603	Geokon	
PB526	Cyl. 3	A	5	0,585	6,603	Geokon	
PB527	Cyl. 4	Center	0	0,100	7,110	Geokon	

Table 6-3. Numbering and position of instruments for measuring pore water pressure (U) in the buffer in hole 5.

Typ and number	Block	Instrument position in block				Fabricate	Remark
		Direction	α degree	r m	Z m		
UB501	Cyl. 1	Center	90	0,050	0,250	Kulite	
UB502	Cyl. 1	Center	90	0,100	0,050	Geokon	
UB503	Cyl. 1	A	355	0,585	0,250	Geokon	
UB504	Cyl. 1	A	355	0,785	0,340	Kulite	
UB505	Ring 5	A	355	0,585	2,786	Geokon	
UB506	Ring 5	A	355	0,785	2,876	Kulite	
UB507	Ring 5	B	85	0,535	2,876	Kulite	In the slot
UB508	Ring 5	B					Not installed
UB509	Ring 5	C	175	0,535	2,786	Geokon	In the slot
UB510	Ring 5	C	175	0,825	2,786	Geokon	In the slot
UB511	Ring 10	A	355	0,585	5,433	Kulite	
UB512	Ring 10	A	355	0,785	5,433	Kulite	
UB513	Cyl. 3	Center					Not installed
UB514	Cyl. 4	Center	90	0,100	6,860	Geokon	

Table 6-4. Numbering and position of instruments for measuring water content (W) in the buffer in hole 5.

Mark	Block	Instrument position in block			Z	Fabricate	Remark
		Direction	α	r			
			degree	m	m		
WB501	Cyl. 1	Center	180	0,050	0,250	Rotronic	
WB502	Cyl. 1	Center	180	0,100	0,050	Rotronic	
WB503	Cyl. 1	Center	0	0,400	0,250	Rotronic	
WB504	Cyl. 1	A	350	0,585	0,340	Vaisala	
WB505	Cyl. 1	A	350	0,685	0,340	Vaisala	
WB506	Cyl. 1	A	350	0,785	0,340	Vaisala	
WB507	Cyl. 1	B	80	0,585	0,340	Vaisala	
WB508	Cyl. 1	B	80	0,685	0,250	Rotronic	
WB509	Cyl. 1	B	80	0,785	0,250	Rotronic	
WB510	Cyl. 1	C	170	0,585	0,250	Rotronic	
WB511	Cyl. 1	C	170	0,685	0,250	Rotronic	
WB512	Cyl. 1	C	170	0,785	0,250	Rotronic	
WB513	Ring 5	A	350	0,585	2,876	Vaisala	
WB514	Ring 5	A	350	0,685	2,876	Vaisala	
WB515	Ring 5	A	350	0,785	2,876	Vaisala	
WB516	Ring 5	B	80	0,535	2,786	Rotronic	In the slot
WB517	Ring 5	B	80	0,685	2,786	Rotronic	
WB518	Ring 5	B	80	0,785	2,786	Rotronic	
WB519	Ring 5	C	180	0,535	2,876	Vaisala	In the slot
WB520	Ring 5	C	180	0,685	2,876	Vaisala	
WB521	Ring 5	C	180	0,785	2,786	Rotronic	
WB522	Ring 10	Center	180	0,050	5,433	Vaisala	
WB523	Ring 10	A	0	0,262	5,433	Vaisala	
WB524	Ring 10	A	350	0,585	5,433	Vaisala	
WB525	Ring 10	A	350	0,685	5,433	Vaisala	
WB526	Ring 10	A	350	0,785	5,433	Vaisala	
WB527	Ring 10	B	80	0,585	5,343	Rotronic	
WB528	Ring 10	B	80	0,685	5,343	Rotronic	
WB529	Ring 10	B	80	0,785	5,343	Rotronic	
WB530	Ring 10	C	170	0,585	5,433	Vaisala	
WB531	Ring 10	C	170	0,785	5,343	Rotronic	
WB532	Cyl. 3	Center	270	0,100	6,353	Vaisala	
WB533	Cyl. 3	A	350	0,585	6,353	Vaisala	
WB534	Cyl. 3	B	90	0,585	6,353	Vaisala	
WB535	Cyl. 3	C	180	0,585	6,353	Rotronic	
WB536	Cyl. 4	Center	180	0,100	6,790	Vaisala	
WB537	Cyl. 4	Center	270	0,100	6,950	Vaisala	

Table 6-5. Numbering and position of instruments for measuring water content (W) in the buffer in hole 5. The positions were determined after inflow measurements.

Mark	Block	Instrument position in block			Z	Fabricate	Remark
		Direction	α	r			
			degree	m	m		
WB538	Ring 3	C-D	225	0,775	1,624	Wescor	
WB539	Ring 3	C-D	235	0,68	1,624	Wescor	
WB540	Ring 3	C-D	245	0,585	1,624	Wescor	
WB541	Ring 3	C-D	255	0,68	1,624	Wescor	
WB542	Ring 3	C-D	265	0,775	1,624	Wescor	
WB543	Ring 8	C-D	225	0,775	4,173	Wescor	
WB544	Ring 8	C-D	235	0,68	4,173	Wescor	
WB545	Ring 8	C-D	245	0,585	4,173	Wescor	
WB546	Ring 8	C-D	255	0,68	4,173	Wescor	
WB547	Ring 8	C-D	265	0,775	4,173	Wescor	

6.3 Position of each instrument in the bentonite in hole 6 (DA3545G01)

The instruments are located in one main level in the blocks, 250 mm, from the upper surface. The upper blocks, C2, C3 and C4 are instrumented in the same way as those in deposition hole 5. The positions of each instrument are described in Tables 6-6 to 6-9. These tables have been updated since the last data report (Sensors data report No 7).

The position of 10 Wescor psychrometers and 5 Vaisala relative humidity sensors were determined after inflow measurement. The positions of these transducers are described in Table 6-10.

Table 6-6. Numbering and position of instruments for measuring temperature (T) in the buffer in hole 6.

Typ and number	Block	Instrument position in block				Fabricate	Remark
		Direction	α degree	r m	Z m		
TB601	Cyl. 1	Center	45	0,050	0,385	Pentronic	
TB602	Cyl. 1	Center	315	0,050	0,260	Pentronic	
TB603	Cyl. 1	Center	0	0,050	0,135	Pentronic	
TB604	Ring 1	D	270	0,535	0,770	Pentronic	
TB605	Ring 1	D	270	0,585	0,770	Pentronic	
TB606	Ring 1	D	270	0,635	0,770	Pentronic	
TB607	Ring 1	D	270	0,685	0,770	Pentronic	
TB608	Ring 1	D	270	0,735	0,770	Pentronic	
TB609	Ring 1	D	270	0,785	0,770	Pentronic	
TB610	Ring 1	D	270	0,825	0,753	Pentronic	On rock
TB611	Ring 1	D	0	0,525	0,753	Pentronic	On canister
TB612	Ring 5	D	270	0,535	2,795	Pentronic	
TB613	Ring 5	D	270	0,585	2,795	Pentronic	
TB614	Ring 5	D	270	0,635	2,795	Pentronic	
TB615	Ring 5	D	270	0,685	2,795	Pentronic	
TB616	Ring 5	D	270	0,735	2,795	Pentronic	
TB617	Ring 5	D	270	0,785	2,795	Pentronic	
TB618	Ring 5	D	270	0,825	2,753	Pentronic	On rock
TB619	Ring 5	D	0	0,525	2,753	Pentronic	On canister
TB620	Ring 8	D	270	0,535	4,324	Pentronic	
TB621	Ring 8	D	270	0,585	4,324	Pentronic	
TB622	Ring 8	D	270	0,635	4,324	Pentronic	
TB623	Ring 8	D	270	0,685	4,324	Pentronic	
TB624	Ring 8	D	270	0,735	4,324	Pentronic	
TB625	Ring 8	D	270	0,785	4,324	Pentronic	
TB626	Ring 8	D	270	0,825	4,253	Pentronic	On rock
TB627	Ring 8	D	0	0,525	4,253	Pentronic	On canister
TB628	Cyl. 3	A	0	0,785	6,366	Pentronic	
TB629	Cyl. 3	B	95	0,585	6,366	Pentronic	
TB630	Cyl. 3	C	185	0,585	6,366	Pentronic	
TB631	Cyl. 4	Center	225	0,100	7,071	Pentronic	
TB632	Cyl. 4	A	0	0,785	7,071	Pentronic	

Table 6-7. Numbering and position of instruments for measuring total pressure (P) in the buffer in hole 6.

Typ and number	Block	Instrument position in block				Fabricate	Remark
		Direction	α degree	r m	Z m		
PB601	Cyl. 1	Center	315	0,210	0,510	Geokon	
PB602	Cyl. 1	B	80	0,685	0,260	Kulite	Vertical
PB603	Ring 1	A	10	0,785	0,770	Kulite	Vertical
PB604	Ring 1	B	80	0,685	0,770	Kulite	Vertical
PB605	Ring 1	C	170	0,585	0,770	Kulite	Vertical
PB606	Ring 2	AB	55	0,735	1,534	Geokon	
PB607	Ring 2	BC	145	0,635	1,534	Geokon	
PB608	Ring 2	CD	215	0,535	1,284	Kulite	In the slot
PB609	Ring 2	DA	325	0,875	1,253	Geokon	At rock
PB610	Ring 5	A	10	0,785	2,795	Kulite	Vertical
PB611	Ring 5	B	80	0,685	2,795	Kulite	Vertical
PB612	Ring 5	C	170	0,585	2,795	Kulite	Vertical
PB613	Ring 6	AB	55	0,785	3,550	Geokon	
PB614	Ring 6	BC	145	0,635	3,550	Geokon	
PB615	Ring 6	CD	215	0,535	3,300	Kulite	In the slot
PB616	Ring 6	DA	325	0,875	3,253	Geokon	At rock
PB617	Ring 8	A	10	0,785	4,324	Kulite	Vertical
PB618	Ring 8	B	80	0,685	4,324	Kulite	Vertical
PB619	Ring 8	C	170	0,585	4,324	Kulite	Vertical
PB620	Ring 9	AB	55	0,735	5,084	Geokon	
PB621	Ring 9	BC	145	0,635	5,084	Geokon	
PB622	Ring 9	CD	215	0,535	4,834	Kulite	In the slot
PB623	Ring 9	DA	325	0,875	4,753	Geokon	At rock
PB624	Cyl. 4	Center	135	0,585	7,121	Kulite	
PB625	Cyl. 3	Center	0	0,100	6,616	Geokon	
PB626	Cyl. 3	A	5	0,585	6,616	Geokon	
PB627	Cyl. 4	Center	0	0,100	7,121	Geokon	

Table 6-8. Numbering and position of instruments for measuring pore water pressure (U) in the buffer in hole 6.

Typ and number	Block	Instrument position in block				Fabricate	Remark
		Direction	α degree	r m	Z m		
UB601	Cyl. 1	Center	280	0,210	0,260	Kulite	
UB602	Cyl. 1	B	95	0,685	0,260	Geokon	
UB603	Ring 2	CD	225	0,535	1,284	Geokon	In the slot
UB604	Ring 2	DA	310	0,875	1,253	Kulite	At the rock
UB605	Ring 5	C	190	0,585	2,795	Geokon	
UB606	Ring 5	A	350	0,785	2,795	Kulite	
UB607	Ring 6	AB	35	0,735	3,300	Kulite	
UB608	Ring 6	BC	125	0,635	3,300	Kulite	
UB609	Ring 6	CD	225	0,535	3,300	Geokon	In the slot
UB610	Ring 6	DA	310	0,875	3,253	Geokon	At the rock
UB611	Ring 9	CD	225	0,535	4,834	Geokon	In the slot
UB612	Ring 9	DA	310	0,875	4,753	Kulite	At the rock
UB613	Cyl. 3	Center	135	0,100	6,366	Kulite	
UB614	Cyl. 4	Center	90	0,100	6,961	Kulite	

Table 6-9. Numbering and position of instruments for measuring water content (W) in the buffer in hole 6.

Typ and number	Block	Instrument position in block				Fabricate	Remark
		Direction	□ degree	r m	Z m		
WB601	Cyl. 1	Center	135	0,050	0,250	Rotronic	
WB602	Cyl. 1	Center	225	0,050	0,250	Wescor	
WB603	Cyl. 1	Center	260	0,210	0,250	Wescor	
WB604	Cyl. 1	Center	270	0,210	0,250	Rotronic	
WB605	Cyl. 1	B	90	0,685	0,250	Wescor	
WB606	Cyl. 1	B	100	0,685	0,250	Rotronic	
WB607	Ring 1	B	90	0,685	0,750	Vaisala	
WB608	Ring 1	B	95	0,685	0,750	Wescor	
WB609	Ring 1	C	180	0,585	0,750	Vaisala	
WB610	Ring 1	C	185	0,585	0,750	Wescor	
WB611	Ring 1	A	355	0,785	0,750	Wescor	
WB612	Ring 1	A	360	0,785	0,750	Wescor	
WB613	Ring 2	AB	40	0,735	1,250	Rotronic	
WB614	Ring 2	AB	45	0,735	1,250	Wescor	
WB615	Ring 2	BC	130	0,635	1,250	Rotronic	
WB616	Ring 2	BC	135	0,635	1,250	Wescor	
WB617	Ring 2	CD	230	0,535	1,250	Rotronic	In the slot
WB618	Ring 2	CD	235	0,535	1,250	Wescor	In the slot
WB619	Ring 2	DA	305	0,875	1,250	Wescor	At rock
WB620	Ring 2	DA	315	0,875	1,250	Rotronic	At rock
WB621	Ring 5	B	90	0,685	2,750	Rotronic	
WB622	Ring 5	B	95	0,685	2,750	Wescor	
WB623	Ring 5	C	180	0,585	2,750	Rotronic	
WB624	Ring 5	C	185	0,585	2,750	Wescor	
WB625	Ring 5	A	355	0,785	2,750	Wescor	
WB626	Ring 5	A	360	0,785	2,750	Rotronic	
WB627	Ring 6	AB	40	0,735	3,250	Vaisala	
WB628	Ring 6	AB	45	0,735	3,250	Wescor	
WB629	Ring 6	BC	130	0,635	3,250	Vaisala	
WB630	Ring 6	BC	135	0,635	3,250	Wescor	
WB631	Ring 6	CD	230	0,535	3,250	Vaisala	In the slot
WB632	Ring 6	CD	235	0,535	3,250	Wescor	In the slot
WB633	Ring 6	DA	305	0,875	3,250	Wescor	At rock
WB634	Ring 6	DA	315	0,875	3,250	Vaisala	At rock
WB635	Ring 8	B	90	0,685	4,250	Rotronic	
WB636	Ring 8	B	95	0,685	4,250	Wescor	
WB637	Ring 8	C	180	0,585	4,250	Rotronic	
WB638	Ring 8	C	185	0,585	4,250	Wescor	
WB639	Ring 8	A	355	0,785	4,250	Wescor	
WB640	Ring 8	A	360	0,785	4,250	Rotronic	
WB641	Ring 9	AB	40	0,735	4,750	Rotronic	
WB642	Ring 9	AB	45	0,735	4,750	Wescor	
WB643	Ring 9	BC	130	0,635	4,750	Vaisala	
WB644	Ring 9	BC	135	0,635	4,750	Wescor	
WB645	Ring 9	CD	230	0,535	4,750	Vaisala	In the slot
WB646	Ring 9	CD	235	0,535	4,750	Wescor	In the slot
WB647	Ring 9	DA	305	0,875	4,750	Wescor	At rock
WB648	Ring 9	DA	315	0,875	4,750	Vaisala	At rock
WB649	Ring 10	Center	90	0,050	5,340	Vaisala	
WB650	Ring 10	Center	270	0,210	5,340	Vaisala	
WB651	Cyl. 3	Center	225	0,100	6,250	Rotronic	
WB652	Cyl. 3	B	90	0,585	6,250	Vaisala	
WB653	Cyl. 3	C	180	0,585	6,250	Rotronic	
WB654	Cyl. 3	A	350	0,585	6,250	Vaisala	
WB655	Cyl. 4	Center	180	0,100	6,680	Rotronic	
WB656	Cyl. 4	Center	270	0,100	6,750	Vaisala	

Table 6-10. Numbering and position of instruments for measuring water content (W) in the buffer in hole 6. The positions were determined after inflow measurements.

Typ and number	Block	Instrument position in block					Remark
		Direction	α degree	r m	Z m	Fabricate	
WB657	Ring 6	C	190	0,625	3,300	Wescor	
WB658	Ring 6	C	190	0,725	3,300	Wescor	
WB659	Rock	C	190	0,900	3,100	Wescor	
WB660	Rock	C	190	0,925	3,250	Wescor	
WB661	Rock	C	190	0,975	3,400	Wescor	
WB662	Ring 8	D	280	0,625	4,324	Wescor	
WB663	Ring 8	D	280	0,725	4,324	Wescor	
WB664	Rock	D	280	0,900	4,100	Wescor	
WB665	Rock	D	280	0,925	4,250	Wescor	
WB666	Rock	D	280	0,975	4,400	Wescor	
WB667	Cyl.1	D	280	0,685	0,260	Vaisala	
WB668	Ring 6	C	200	0,625	3,300	Vaisala	
WB669	Ring 6	C	200	0,725	3,300	Vaisala	
WB670	Ring 8	D	290	0,625	4,324	Vaisala	
WB671	Ring 8	D	290	0,725	4,324	Vaisala	

6.4 Instruments on the canister surface in holes 5-6

A system for measuring the temperature with optical cables on the surface of the canisters is used in the same way as for the canisters in Section 1. The system is described in chapter 4.4.

In addition to the optical cables three thermocouples (TB504, TB511 and TB524) in deposition hole 5 and three thermocouples (TB611, TB619 and TB627) in deposition hole 6 are fixed to the surface of the canister (see Table 6-1 and 6-6).

6.5 Position of temperature sensors in the rock

Thermocouples are placed on 3 levels in each deposition hole (bottom, 3 m and 6 m level). On level 3 m and 6 m the thermocouples are placed in two directions perpendicular to each other.

The positions are described in Table 6-11.

Table 6-11. Numbering and position of temperature sensors in the rock.

Type and number	Distance from rock surface(m)	α degree	r m	Z m	Remark
Measured from DA3551G01(Hole 5)					
TR5011	1,000	0°	0,000	-1,000	Bottom
TR5012	0,500	0°	0,000	-0,500	Bottom
TR5013	0,200	0°	0,000	-0,200	Bottom
TR5014	0,000	0°	0,000	0,000	Bottom
TR5021	2,200	180°	3,075	6,000	East
TR5022	1,100	180°	1,975	6,000	East
TR5023	0,600	180°	1,475	6,000	East
TR5024	0,200	180°	1,075	6,000	East
TR5025	0,000	180°	0,875	6,000	East
TR5031	2,200	90°	3,075	6,000	South
TR5032	1,100	90°	1,975	6,000	South
TR5033	0,600	90°	1,475	6,000	South
TR5034	0,200	90°	1,075	6,000	South
TR5035	0,000	90°	0,875	6,000	South
TR5041	2,200	180°	3,075	3,000	East
TR5042	1,100	180°	1,975	3,000	East
TR5043	0,600	180°	1,475	3,000	East
TR5044	0,200	180°	1,075	3,000	East
TR5045	0,000	180°	0,875	3,000	East
TR5051	2,200	90°	3,075	3,000	South
TR5052	1,100	90°	1,975	3,000	South
TR5053	0,600	90°	1,475	3,000	South
TR5054	0,200	90°	1,075	3,000	South
TR5055	0,000	90°	0,875	3,000	South
Measured from DA3545G01(Hole 6)					
TR6011	1,000	0	0,000	-1,000	Bottom
TR6012	0,500	0	0,000	-0,500	Bottom
TR6013	0,200	0	0,000	-0,200	Bottom
TR6014	0,000	0	0,000	0,000	Bottom
TR6021	2,200	90°	3,075	6,000	South
TR6022	1,100	90°	1,975	6,000	South
TR6023	0,600	90°	1,475	6,000	South
TR6024	0,200	90°	1,075	6,000	South
TR6025	0,000	90°	0,875	6,000	South
TR6031	2,200	360°	3,075	6,000	West
TR6032	1,100	360°	1,975	6,000	West
TR6033	0,600	360°	1,475	6,000	West
TR6034	0,200	360°	1,075	6,000	West
TR6035	0,000	360°	0,875	6,000	West
TR6041	2,200	90°	3,075	3,000	South
TR6042	1,100	90°	1,975	3,000	South
TR6043	0,600	90°	1,475	3,000	South
TR6044	0,200	90°	1,075	3,000	South
TR6045	0,000	90°	0,875	3,000	South
TR6051	2,200	360°	3,075	3,000	West
TR6052	1,100	360°	1,975	3,000	West
TR6053	0,600	360°	1,475	3,000	West
TR6054	0,200	360°	1,075	3,000	West
TR6055	0,000	360°	0,875	3,000	West

6.6 Strategy for describing the position of each device in the backfill in section 2

The strategy for instrumentation of the backfill in Section 2 is the same as in Section 1 and is described in chapter 4.6.

6.7 Position of each instrument in the backfill in Section 2

The positions of each instrument are described in Tables 6-12 to 6-15.

Table 6-12. Numbering and position of instruments for measuring temperature (T) in the backfill in section 2.

Type and number	Instrument position			Fabricate	Remark
	Section	x	z		
		m	m	m	
TFA01	E, over dep.hole 5	0,0	2,3	3551,0	Pentronic
TFA02	E, over dep.hole 5	0,0	1,25	3551,0	Pentronic
TFA03	E, over dep.hole 5	0,0	-0,8	3551,0	Pentronic
TFA04	E, over dep.hole 5	-0,5	-2,6	3551,0	Pentronic
TFA05	E, over dep.hole 5	0,5	-2,6	3551,0	Pentronic
TFA06	E, over dep.hole 5	-1,25	0,0	3551,0	Pentronic
TFA07	E, over dep.hole 5	1,25	0,0	3551,0	Pentronic
TFA08	F, between dep.hole 5 and 6	0,0	1,0	3548,0	Pentronic
TFA09	F, between dep.hole 5 and 6	0,0	-1,25	3548,0	Pentronic
TFA10	E, over dep.hole 6	0,0	2,3	3545,0	Pentronic
TFA11	E, over dep.hole 6	0,0	1,25	3545,0	Pentronic
TFA12	E, over dep.hole 6	0,0	-0,8	3545,0	Pentronic
TFA13	E, over dep.hole 6	-0,5	-2,6	3545,0	Pentronic
TFA14	E, over dep.hole 6	0,5	-2,6	3545,0	Pentronic
TFA15	E, over dep.hole 6	-1,25	0,0	3545,0	Pentronic
TFA16	E, over dep.hole 6	1,25	0,0	3545,0	Pentronic

Table 6-13. Numbering and position of instruments for measuring total pressure (P) in the backfill in section 2.

Type and number	Instrument position			Fabricate	Remark
	Section	x	z		
		m	m	m	
PFA01	Inner part	0,0	0,0	3555,8	Kulite
PFA02	E, over dep.hole 5	0,0	0,0	3551,0	Geokon
PFA03	E, over dep.hole 5	0,0	-1,75	3551,0	Geokon
PFA04	E, over dep.hole 5	0,0	-2,6	3551,0	Geokon
PFA05	E, over dep.hole 5	0,0	-3,15	3551,0	Kulite
PFA06	E, over dep.hole 5	-2,3	0,0	3551,0	Kulite
PFA07	E, over dep.hole 5	0,0	2,3	3551,0	Kulite
PFA08	F, between dep.hole 5 and 6	0,0	0,0	3548,0	Geokon
PFA09	F, between dep.hole 5 and 6	0,0	-2	3548,0	Geokon
PFA10	E, over dep.hole 6	0,0	0,0	3545,0	Kulite
PFA11	E, over dep.hole 6	0,0	-1,75	3545,0	Kulite
PFA12	E, over dep.hole 6	0,0	-2,6	3545,0	Kulite
PFA13	E, over dep.hole 6	0,0	-3,15	3545,0	Geokon
PFA14	E, over dep.hole 6	-2,3	0,0	3545,0	Geokon
PFA15	E, over dep.hole 6	0,0	2,3	3545,0	Geokon
PFA16	In front of plug	0,0	0,0	3539,0	Kulite

Table 6-14. Numbering and position of instruments for measuring pore water pressure (U) in the backfill in section 2.

Type and number	Instrument position			Fabricate	Remark
	Section	x	z		
		m	m	m	
UFA01	Inner part	0,0	0,0	3555,8	Kulite
UFA02	Inner part	0,0	0,0	3554,1	Geokon
UFA03	E, over dep.hole 5	0,0	0,0	3551,0	Geokon
UFA04	E, over dep.hole 5	0,0	-1,75	3551,0	Kulite
UFA05	E, over dep.hole 5	0,0	-2,6	3551,1	Kulite
UFA06	E, over dep.hole 5	0,0	-3,15	3551,0	Kulite
UFA07	E, over dep.hole 5	0,0	-1,75	3551,0	Geokon
UFA08	E, over dep.hole 5	0,0	2,3	3551,0	Geokon
UFA09	F, between dep.hole 5 and 6	0,0	0,0	3548,0	Geokon
UFA10	F, between dep.hole 5 and 6	0,0	-2,0	3548,0	Geokon
UFA11	E, over dep.hole 6	0,0	0,0	3545,0	Geokon
UFA12	E, over dep.hole 6	0,0	-1,75	3545,0	Geokon
UFA13	E, over dep.hole 6	0,0	-2,6	3545,0	Geokon
UFA14	E, over dep.hole 6	0,0	-3,15	3545,0	Geokon
UFA15	E, over dep.hole 6	-2,3	0,0	3545,0	Geokon
UFA16	E, over dep.hole 6	0,0	2,3	3545,0	Geokon
UFA17	In front of plug	-2,3	0,0	3551,0	Geokon
UFA18	In front of plug	0,0	0,0	3539,0	Geokon

Table 6-15. Numbering and position of instruments for measuring relative humidity (W) in the backfill in section 2.

Type and number	Instrument position			Fabricate	Remark	
	Section	x	z			y
		m	m	m		
WFA01	Inner part	0,0	0,0	3555,8	Wescor	
WFA02	Inner part	0,0	0,0	3554,1	Wescor	
WFA03	E, over dep.hole 5	0,0	2,3	3551,0	Wescor	
WFA04	E, over dep.hole 5	0,0	1,25	3551,0	Wescor	
WFA05	E, over dep.hole 5	0,0	0,0	3551,0	Wescor	
WFA06	E, over dep.hole 5	0,0	-0,8	3551,0	Wescor	
WFA07	E, over dep.hole 5	2,3	0,0	3545,0	Wescor	
WFA08	E, over dep.hole 5	0,0	-2,6	3550,9	Wescor	
WFA09	E, over dep.hole 5	0,0	-3,15	3551,0	Wescor	
WFA10	E, over dep.hole 5	-2,3	0,0	3551,0	Wescor	
WFA11	E, over dep.hole 5	-1,25	0,0	3551,0	Wescor	
WFA12	E, over dep.hole 5	1,25	0,0	3551,0	Wescor	
WFA13	E, over dep.hole 5	2,3	0,0	3551,0	Wescor	
WFA14	F, between dep.hole 5 and 6				Wescor	Not clear
WFA15	F, between dep.hole 5 and 6	0,0	1,0	3548,0	Wescor	
WFA16	F, between dep.hole 5 and 6	0,0	0,0	3548,0	Wescor	
WFA17	F, between dep.hole 5 and 6	0,0	-0,55	3548,0	Wescor	
WFA18	F, between dep.hole 5 and 6	-1,25	0,0	3548,0	Wescor	
WFA19	F, between dep.hole 5 and 6	1,25	0,0	3548,0	Wescor	
WFA20	E, over dep.hole 6	0,0	2,3	3545,0	Wescor	
WFA21	E, over dep.hole 6	0,0	1,25	3545,0	Wescor	
WFA22	E, over dep.hole 6	0,0	0,0	3545,0	Wescor	
WFA23	E, over dep.hole 6	0,0	-0,8	3545,0	Wescor	
WFA24	E, over dep.hole 6	0,0	-1,75	3545,0	Wescor	
WFA25	E, over dep.hole 6	0,0	-2,6	3545,0	Wescor	
WFA26	E, over dep.hole 6	0,0	-3,15	3545,0	Wescor	
WFA27	E, over dep.hole 6	-2,3	0,0	3545,0	Wescor	
WFA28	E, over dep.hole 6	-1,25	0,0	3545,0	Wescor	
WFA29	E, over dep.hole 6	1,25	0,0	3545,0	Wescor	
WFA30	E, over dep.hole 6	0,0	2,3	3548,0	Wescor	
WFA31	In front of plug	0,0	0,0	3540,0	Wescor	
WFA32	In front of plug	0,0	0,0	3539,0	Wescor	

7 Results and comments for Section 2

7.1 General

In this chapter short comments on general trends in the measurements are given. Sensors that are not delivering reliable data or no data at all are noted and comments on the data collection in general are given.

The heating of the canister in hole 5 started with an applied constant power of 1800 W at 030508. This date is also marked as start date. The backfilling started 030429 and was finished 030625 and the plug was cast at 030911. Table 7-1 shows some important dates for section 2. At the beginning of November 2004 the drainage of the inner part of Section 1 and the drainage trough the outer plug were closed. At the beginning of December 2004 damages were observed on one canister in Section 1 (No 1) and one in Section 2 (No 6) probably due to high water pressure in the buffer and backfill. It was then decided to switch off the power to all canisters. This was done on December 2. The drainage of the tunnel was opened on December 6 and investigations on the damaged canisters were initialized. The power to all the canisters, except for canister 2, was on December 15 switched on. The drainage of the tunnel was kept open. Additional problems with canister 6 were observed September 2005 and the power to the canister was switched off for about 2 months.

Since the start of the test the power to the two canisters has been reduced with 30 W at four occasions and the power was about 1680 W at the beginning of May 2008. Then, the power for canister 6 was reduced with about 200 W due to new problems with the heaters. Another reduction of the power for canister 6 was made at the beginning of June 2008 also due to heater problems. After the latest reduction the power to canister 6 was about 1150 W.

At present about 135 (excluding water pressure sensors in the rock and the displacement sensors for the canister) out of totally 394 installed sensors are out of order. In Figure 7-1 the numbers of still working sensors in the backfill and the buffer of Section 2 are plotted as function of time from June 2004. The figure shows that the majority of the broken sensors are RH-sensors and that the numbers of broken sensors increased after the closing of the drainage of the tunnel.

The measured processes in the buffer and the backfill were slow up to about 20 days after the drainage of the tunnel was closed. Very small changes of the measured parameters have occurred up to that date. After that the readings from some of the total and pore pressure sensors placed in the buffer have reacted strongly (quick increase in pressure). Also the total and pore pressure sensors placed in the backfill have recorded high pressures caused by the closing of the drainage. After the opening of the drainage of the tunnel, both the pore pressures and the total pressures were stabilized on a higher level than before the closing of the drainage.

The measured maximum temperature is on the canister in deposition hole 5 about 84 °C. For the canister in deposition hole 6 is the highest temperature about 82 °C.

Table 7-1. Key dates for section 2.

Activity	Date
Start backfilling	29/4 2003
Start heating canister 5	8/5 2003
Start heating canister 6	23/5 2003
Finished backfilling	25/6 2003
Plug casting	11/9 2003
Decreased power (-30 W)	8/9 2004
The power to all canisters was switched off	2/12 2004
The drainage of the tunnel was opened	6/12 2004
The power to the canisters was switched on	15/12 2004
The power to canister 6 was switched off	6/9 2005
The power to canister 6 was switched on	2/11 2005
Decreased power (-30 W)	2/12 2005
Decreased power (-30 W)	21/12 2006
Decreased power (-30 W)	11/12 2007
The power to canister 6 was decreased with about 200 W due to problems with the heaters	8/4 2008
The power to canister 6 was decreased with about 300 W due to problems with the heaters	5/6 2008

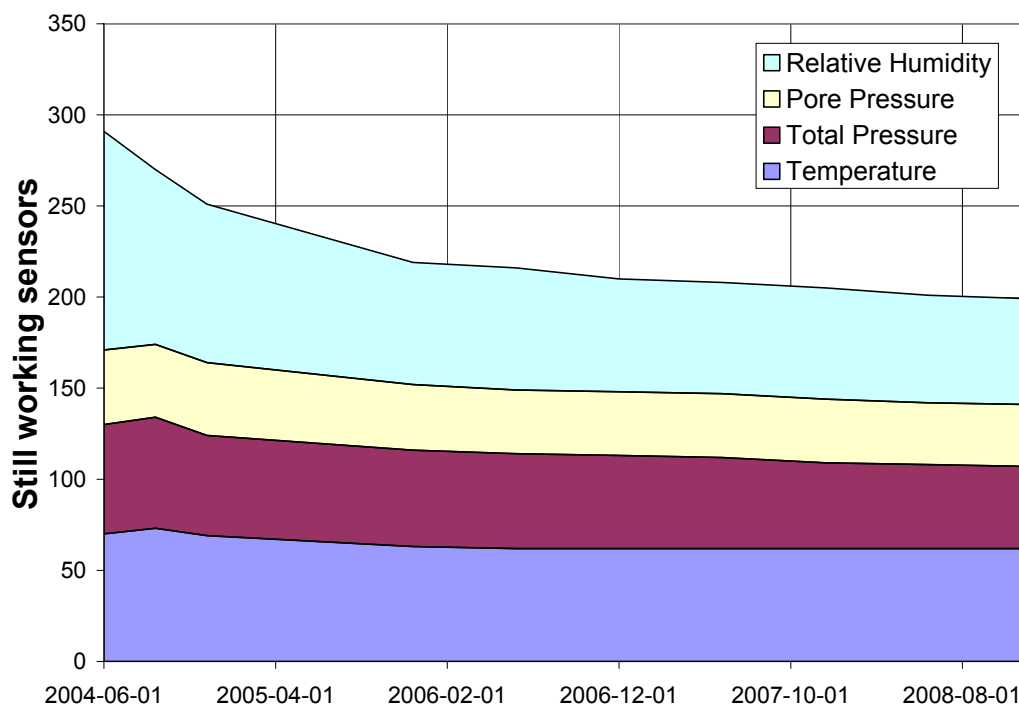

Figure 7-1. The numbers of still working sensors placed in the buffer and backfill in Section 2 as function of time. The coloured fields are representing the four types of installed sensors.

7.2 Deposition hole 5

7.2.1 Total pressure

Geokon (App. 5\pages 189-192)

The measured pressure range is from 0 to 9.5 MPa. PB506 placed in block C1 shows a strong increasing of the total pressure since day 200. Two sensors (PB508 and PB509) placed in block C1 at the direction of about 180 ° both started to measure an increase of the pressure around day 700 and are at the end of this measuring period measuring pressures of about 6 MPa.

High pressures are also indicated by sensors in block R5 and R10. PB511 in block R5 showed a very quick increase in pressure from day 520 up to the day when the power was switched off. After that a drop in pressure of 2 MPa was observed and then an increase in pressure to about 9 MPa. The pressure dropped then to about 6 MPa during a period of 200 days. The pressure was then stabilized on that level for about 250 days. After that period is the sensor showing an increasing pressure with the time. The pressure increased to about 7 MPa at around day 1500 when the sensor failed. The two still working sensors in block R5 are measuring pressures 7.5 - 10 MPa at the end of this measuring period.

Two sensors placed in block R10 (PB521 and PB522) showed a drop in total pressure at around day 300 and then they were stabilized on a pressure of about 2 MPa. The two sensors measured an increase in pressure when the drainage was closed. When the power to the canister was switched off the measured pressures decreased quickly with about 1 MPa. After the power was switched on again the measured pressures increased very quickly to the same level as before the power was switched off. The measured pressures are continuing to increase and are at the end of this measuring period about 5 MPa.

Two sensors (of totally three installed sensors) placed in block C4 are measuring a total pressure higher than 1 MPa.

Five sensors are out of order.

Kulite (App. 5\page 193)

Two sensors placed in block C1 are measuring low pressures, lower than 500 kPa. The measured pressures started to increase during this measuring period.

One sensor placed at the inner surface of block R5 (PB510) started to measure an increase in pressure around day 250 which might indicate that water entered the inner slot at that time. The sensor measured a maximum pressure of about 2.5 MPa just before it was broken.

Two sensors PB519 and PB520, placed in block R10 are measuring pressures higher than 2 MPa at the end of this measuring period and a third sensor in block R5 (PB518) is measuring a pressure of about 1 MPa.

Three sensors are out of order.

7.2.2 Relative humidity/suction in dep. hole 5

Vaisala (App. 5\pages 194-197)

Since temperature is also measured with all relative humidity sensors, the diagrams include those measured temperatures. The temperature measurements start at about 16 degrees while the RH measurements start at about 70 % RH.

The sensors placed in the bottom block C1 show very small changes in RH with time. The measured relative humidity varies between 70-85 %.

One sensor placed in block R5 close to the canister (WB519) indicated a very strong drying of the bentonite until day 170 when it stopped to give reliable values. Sensor WB520 placed in the middle of block R5 indicated also an initial drying of the bentonite. The rest of the sensors in block R5 indicate a slowly wetting of the buffer (increase in RH).

Two sensors in block R10 placed close to the top of the canister (WB522, WB523) indicated a drying of the bentonite up to day 350 and after that a slowly wetting. The rest of the sensors in block R10 indicate initially a wetting of the buffer. The relative humidity at the end of this measuring period varies between 65% close to the canister lid and 85% at the periphery of the bentonite block.

Two still working sensors placed in block C3 and C4 indicate a slowly wetting of the buffer and are measuring a RH of about 87% at the end of this measuring period.

Twelve sensors are out of order.

Rotronic (App. 5\pages 198-202)

Seven of the sensors placed in the bottom block C1 show a slow increase in RH with the time. The measured RH in block C1 varies between 75-98 % at the end of this measuring period.

One sensor placed in block R5 close to the canister (WB516) indicated a very strong drying of the bentonite for the first 60 days. The sensor indicated then a wetting for the next 60 days and after that another period of drying until day 230. After that the sensor is measuring an increase in Relative Humidity indicating a wetting of the buffer until it stopped giving reliable values.

All the sensors in block R10 have stopped giving reliable values.

One sensor placed in block C3 indicates a slowly wetting of the bentonite and is at the end of this measuring period recording a Relative Humidity of 100 %.

Nine sensors are out of order.

Wescor Psychrometers (App.5\page 203)

The Wescor sensors can measure suction between 6000 and 200 kPa.

Four of totally ten sensors have started to measure a decrease in suction of the buffer. These sensors (WB538, WB539, WB541 and WB542) are placed near the periphery of block R3. All of these sensors have stopped giving reliable values.

7.2.3 Pore water pressure

Geokon (App. 5\page 204)

All sensors yield very low pressures.

Kulite (App. 5\page 205)

Sensors UB508 was out of order from start and it is not plotted in this report.

One sensor placed in block R5 yields a pressure of about 0.6 MPa at the end of this measuring period. The rest of the installed sensor are measuring very low pressures.

Three sensors are out of order.

7.2.4 Temperature in the buffer (App. 5\pages 206-215)

Three thermocouples (TB504, TB511 and TB524) are placed on the surface of the canister. TB504 placed close to the bottom of the canister shows a temperature of about 68 °C , TB511 placed at the middle of canister about 73 °C and TB524 placed close to the top of the canister shows a temperature of about 66 °C.

High temperatures are measured with thermocouples placed in the centre of block C1 and just below the canister (TB503, 64 °C) and in block R5 (TB513, 70 °C). The temperature gradient over block R5 (between the radius 585 mm and 785 mm) is at the end of this measuring period about 0.64 °C/cm.

The temperature in the buffer is also measured with the Geokon sensors. The maximum temperature recorded with these sensors is about 65 °C at the end of this measuring period (PBU502 placed in the centre of block C1 close to the canister).

The temperature in the buffer is also measured with the Wescor sensors. The maximum temperature recorded at the end of this measuring period with these sensors is about 63 °C.

7.2.5 Canister power (App. 5\page 221)

The power of the canister in hole 5 was kept constant at 1800 W from the start 2003-05-08 until the beginning of September 2004 when the power was decreased to about 1770 W. During the period between December 6 (day 575) and December 15 (day588) the power to the canister was switched off. After that period the power was adjusted to about 1770 W again. At the beginning of December 2005, 2006 and 2007 the power was decreased with 30 W. After the latest reduction the power of the canister is about 1680 W.

Due to problems with the data collection system, data is missing for the first 45 days of the heating.

7.2.6 Temperature on the canister surface (App. 5\pages 222-224)

The first diagram shows the maximum temperature, measured with the optical cables placed on the surface of the canister, plotted as function of time. The maximum measured temperature on the canister surface is about 88 °C. With no damages on the optical cables this plot should have four curves. Only one curve with relevant values is presented here up to May 2007 which indicates that the optical cables are damaged. The second diagram shows the distribution of the temperature along the optical cables at December 1 2006. The length of the cables on the canister surface is about 20 m. The variation of a few degrees is caused by the difference in temperature in the centre and ends of the canister. In May 2007 the optical system for measuring the temperature on this canister stopped functioning.

7.3 Deposition hole 6

7.3.1 Total pressure

Geokon and Kulite (App. 6\pages 227-230)

The results from two types of sensors are presented in the same plot.

The measured pressure range is from 0 to 11.7 MPa. Two sensors, PB624 and PB627 placed in the top block (C4) showed an increase in pressure with about 1.5 MPa when the drainage of the tunnel was closed. Two sensors in block C3 and C4 are measuring pressures between 1.5 – 2.1 MPa at the end of this measuring period.

Three sensors placed in Block R1 and R2, PB603, PB606 and PB607, showed an increase in pressure up to the point where the power to the canister was reduced to ~1500 W when a drop in the measured pressures was observed. The sensor recorded another drop in pressure when the power was reduced to ~1250 W at the beginning of this measuring period. The three sensors were measuring a pressure of about 11 MPa at the end of this measuring period.

Three sensors placed in Block R5 and R6 are measuring a pressure of about 8 MPa at the end of this measuring period.

Three of the sensors placed in Block R8 and R9 (PB620, PB621 and PB623) showed a strong increase in pressure after the power was switched on again at the end of year 2004. All the sensors reacted also with a rapid decrease in pressure when the power to canister 6 was switched off for the second time. After the drop in pressure most of the sensors started to measure an increase in pressure even though the power was not switched on. The measured total pressure in Block R8 and R9 varies between 2.5 and 6.5 MPa at the end of this measuring period.

Nine sensors (eight Kulite and one Geokon) are out of order.

7.3.2 Relative humidity/Suction

Vaisala and Rotronic (App. 6\pages 231-237)

The results from two types of sensors are presented in the same plot.

The sensors placed in the bottom block C1 show small changes in RH with the time. At the end of this measuring period two sensors are measuring a relative humidity of about 98%.

Two sensors placed in block R1 and R2 indicated a very quick increase in RH when the drainage was closed.

All sensors placed in block R5 and R6 stopped giving reliable values of the RH after the drainage was closed.

One sensor placed close to the canister in block R9 (WB645) indicates a drying of the buffer. The rest of the sensors in block R8 and R9 indicate a slowly wetting of the buffer up to the time when the drainage was closed. At that point a quick increase in RH was measured by several sensors and most of them stopped give reliable values after that period.

Two sensors (WB649, WB650) placed in block R10 and at the top of the canister indicated an initial wetting of the bentonite and then a continuing drying. The two sensors stopped giving reliable values around day 600 (when the drainage of the tunnel was closed).

The sensors placed in block C3 and C4 show very small changes in RH with the time.

Sensors WB606, WB634 and WB648 were out of order at the start of the heating phase and are not plotted in this report.

32 of the initial 37 installed sensors are out of order.

Wescor Psychrometers (App. 6\page 238-242)

Seven of totally nine sensors installed in the rock wall have measured suction in the rock since the start of the test. Twelve of totally 26 sensors installed in the buffer are giving reliable values at the end of this measuring period.

7.3.3 Pore water pressure

Geokon and Kulite (App. 6\pages 243-245)

Two installed sensors yield pressures higher than 0.5 MPa. One sensor is placed in block R6 close to the outer radius of the block and the other one is placed in Block R1 close to the inner slot.

Three sensors (Kulite) are out of order.

7.3.4 Temperature in the buffer (App. 6\pages 246-259)

Due to problems with the heaters in the canister the power was reduced with about 200 W around day 1800 and with about 300 W around day 1860 (see Section 7.3.5). These reductions affected the measured temperatures in the buffer.

Three thermocouples (TB611, TB619 and TB627) are placed on the surface of the canister. TB611 placed close to the bottom of the canister showed a temperature at the end of this measuring period of about 52 °C while TB619 placed at the middle of canister showed a temperature of 57 °C. TB627 placed close to the top of the canister was measuring a temperature of about 55 °C.

The maximum temperature in the buffer recorded at the end of this measuring period is 55 °C. It was measured in block R5, close to the canister (TB612). The temperature plot for this sensor indicates that the thermocouple is in contact with the canister. When this sensor is excluded the maximum temperature gradient over block R5 is about 0.46 °C/cm.

Eleven thermocouples are out of order.

The temperature in the buffer is also measured by the installed Geokon sensors. The maximum temperature recorded with these sensors at the end of this measuring period is about 56 °C (UB609 placed in block R2 close to the canister). Five sensors are out of order.

The temperature in the buffer is also measured with the Wescor sensors. The maximum temperature recorded with these sensors is about 57 °C at the end of this measuring period. The sensor is placed in block R5 close to the canister surface.

7.3.5 Canister power (App. 6\page 263)

The power of the canister in hole 6 has been kept constant at 1800 W from the start 2003-05-08 to the beginning of September 2004 when the power was decreased to about 1770 W. During the period between December 6 (day 575) and December 15 (day 588) the power to the canister was switched off. After that period the power was adjusted to about 1770 W. During a period of about 2 months (from August 2) the power was switched off again and after that the power was adjusted to 1770 W again. At the beginning of December 2005, 2006 and 2007 the power was decreased with 30 W. Due to problems with the heaters the power was reduced with about 200 W at the beginning of May 2008. Another reduction of the power was made at the beginning of June 2008 also due to heater problems. After the latest reduction the power was about 1150 W.

Due to problems with the data collection system, data is missing for the first 30 days of the heating phase.

7.3.6 Temperature on the canister surface (App. 6\pages 264-266)

The first diagram shows the maximum temperature plotted as a function of time. The average maximum measured temperature on the canister surface at the end of this measuring period is about 76 °C. The second diagram shows the distribution of the temperature along the optical cables at the end of this measuring period. The maximum

temperature has decreased with about 9 °C after the switch off/switch on of the power at the end of year 2004. The temperature has all about recovered from the latest period when the power was switched off. With no damages on the optical cables this plot should have four curves. Only two curves with relevant values are available which indicates that the optical cables are damaged. The length of the cables on the canister surface is about 20 m. The variation of a few degrees is caused by the difference in temperature at the centre and ends of the canister. The optical system stopped giving reliable values at around day 1300.

7.4 Backfill in Section 2

7.4.1 Total pressure

Geokon (App. 7\page 269)

All the total pressure sensors measured an increase pressure, of about 1.5 MPa, after the drainage of the tunnel was closed. The highest total pressures before the closing of the drainage, 400 kPa, was measured by the sensor PFA13. This sensor is placed just above the bentonite surface in the deposition hole 6. The rest of the total pressure sensors measured very low pressures before the closing of the drainage. However, all installed sensors indicated a decrease in pressure when the drainage was opened again. The maximum measured pressure just after the opening of the drainage was about 0.4 MPa. All the sensors recorded a slow increase in pressure although the drainage was kept open. Just before the power to canister 6 was switched off again at the beginning of September 2005 the maximum recorded pressure was about 1 MPa. All the sensors indicated a decrease in pressure when the power to canister 6 was switched off. When the power was switched on the pressure started to slowly increase again and the maximum pressure recorded at around day 1450 was about 1.2 MPa. After that all the sensors were measuring an increase in pressure of about 0.3 MPa. This increase in pressure is caused by the initial hydraulic tests made for the construction of a new tunnel close to the Prototype-tunnel. The pressures have during the last 1.5 years varied a lot due to the work with the new tunnel. The maximum recorded pressure at the end of this measuring period is about 1.9 MPa. This pressure is in the same range as the pressure measured at the closing of the drainage of the tunnel.

Kulite (App.7 \page 270)

These sensors measured also an increase in total pressure of about 1.5 MPa due to the closing of the drainage. The highest pressure before the closing of the drainage was measured by the sensor PFA12, about 0.4 MPa. This sensor is placed just above the bentonite surface in deposition hole 6. The rest of the total pressure sensors measured very small pressures before the drainage closing. After the reopening of the drainage, all the sensors recorded a drop in total pressure. The measured pressure started to slowly increase although the drainage was kept open. When the power to canister 6 was switched off again at the beginning of September 2005 the maximum recorded pressure decreased to 0.6 MPa and after that the pressure started to slowly increase again and the maximum pressure recorded at around day 1450 was about 1.2 MPa. Also these sensors were measuring an increase in pressure of about 0.3 MPa when tests made for the new tunnel closed to the Prototype-tunnel started. The pressures have during the last 1.5 years varied a lot due to the work with the new tunnel and the maximum measured pressure at the end of this period is about 1.6 MPa.

7.4.2 Suction (App. 7 \pages 271-277)

The suction in the backfill is measured with Wescor psychrometers. Most of the psychrometers yield suction values between 2500 and 3500 kPa at the start of the test, which correspond to the initial suction at a water ratio in the backfill of 12%. Some sensors have clearly being wetted to almost fully saturation (suction below 1500 kPa) very short after the start of the test. These sensors (WFA12, WFA20, and WFA27) are placed close the rock surface. A decrease in suction and thus a wetting of the backfill was indicated by the rest of the sensors until the closing of drainage of the tunnel. All of the still working sensors were after this event showing a quicker decrease in suction. None of the installed sensors are giving reliable values at the end of this measuring period.

The position of WFA14 is not clear and the sensor is not plotted in this report.

7.4.3 Pore water pressure

Geokon (App. 7\pages 278-280)

All the sensors, except one (UFA11), showed an increase in pore pressure, about 1.5 MPa, after the closing of the tunnel drainage. The sensors recorded very low pressures before this event. After the drainage was reopening all sensors placed close to the tunnel surface indicated a slow increase in pore pressure. Just before the power to canister 6 was switched off again at the beginning of September 2005 the average recorded pressure was 0.5 MPa. The pressure dropped then with about 0.2 MPa with a subsequent slowly increase in pressure. The average pressure for these sensors was about 0.5 MPa around day 1450. Also these sensors were measuring an increase in pressure of about 0.3 MPa when the tests for the new tunnel started. The measured pressures during the last 1.5 year have varied due to the work with the new tunnel and the maximum measured pressure at the end of this period is about 1.4 MPa.

Kulite (App. 7\page 281)

Three of the sensors showed an increase in pore pressure, about 1.5 MPa, after the closing of the tunnel drainage. The sensors recorded very low pressures before this event. After the drainage was reopened again, the two still working sensors measured maximum values of about 0.55 MPa. When the power to canister 6 was switched off again the pressures dropped with about 0.2 MPa. The still working sensor measured a pressure of about 0.5 MPa around day 1450. The measured pressure increased then with about 0.3 MPa caused by the work with the new tunnel. The work with the new tunnel has also affected this sensor during the last 1.5 year and the maximum measured pressure at the end of this measuring period is about 1.2 MPa.

Three sensors are out of order.

7.4.4 Temperature (App. 7\pages 282-284)

The temperature in the backfill ranges from 20 to 32 °C. The highest temperatures is as expected measured just above the buffer in hole 5. When the power to canister 6 was switched off at the beginning of September 2005 the temperature in the backfill close to upper surface of the buffer in deposition hole 6 dropped with about 2 °C but increased when the power was switched on again. A decrease in temperature is also recorded during this measuring period due to the reduction of the power to canister 6.

7.5 Temperature in the rock

7.5.1 Near hole 5 (App. 5\pages 216-220)

The maximum temperature in the rock (55 °C) is measured by TROA5045 located at rock surface near the centre of the canister in deposition hole 5.

7.5.2 Near hole 6 (App. 6\pages 260-262)

The maximum temperature in the rock just before the power to canister 6 was switched off (54 °C) was measured by TROA6055. The sensor is located at rock surface near the centre of the canister in deposition hole 6. All the sensors placed close to deposition hole measured a drop in temperature when the power was switched off at three occasions since the start of the test. After the two latest reduction of the power to the canister with about 200 and 300 W the temperature measured by the sensor placed at mid height of the canister and at the surface of the deposition hole dropped with about 8 °C to a maximum temperature of about 46 °C.

7.6 Analyze of data from Section 2

7.6.1 Deposition hole 5

The saturation of the buffer in deposition hole 5 indicated by both RH sensors and total pressure sensors is complex. Some total pressure sensors indicate rather high total pressures (higher than 2.5 MPa) while others measure very low pressures. The sensors giving high pressures are placed in block C1, R5 and R10. There are also some RH-sensors which are measuring relative humidity of ~100%, indicating a high saturation of the buffer. In other parts of the buffer most of the sensors (both RH-sensors and total pressure sensors) indicate a slow wetting of the buffer with time. Although the sensors reacted rather strongly just before and after the power was switched on and off at the beginning of December 2004, the saturation rate indicated by the sensors is not changed radically over the time. One sensor (PB510), measuring the total pressure in block R5 at the inner slot towards the canister, measured a maximum pressure of about 2600 kPa before it stopped giving reliable values. This sensor started to react around day 200 which might be an indication of the time when the inner slot was closed.

In Figure 7-2 the temperature for deposition hole 5 is plotted as function of the radial distance from the centre of the deposition hole at mid height of the canister. Compared the corresponding plots for deposition hole 3 these plots do not show a drop in temperature between the surface of the canister and the buffer (inner diameter of the ring) although the temperature gradient is higher close to the canister surface. The temperature on the canister surface is also much lower compared to canister 3. These measurements indicate that the initial slot between the buffer and the canister of about 10 mm is not present anymore, but the closing of the slot is not associated with the high pressures generated in the buffer and backfill at the closing of the tunnel drainage.

The temperature gradient over the inner part of the buffer together with the temperature on the canister and the temperature at the radius of 600 mm in the ring shaped block R5 are plotted as function of time in Figure 7-3. The shaded part of the plot is representing the time when the power to the canisters was switched off. The plot shows that both the temperature and the temperature gradient were affected very little by the switch off/on

of the power. The plot is indicating that there is decrease in the temperature gradient after the power was switched on again. The plot is also showing that the temperature gradient is decreasing towards a value similar as for the outer part of the (about 0.5 C°/cm).

The temperature gradient over the outer part of the buffer is plotted in Figure 7-4. After the power was switched on again this gradient is also stabilized on about the same level as before the power was switched off.

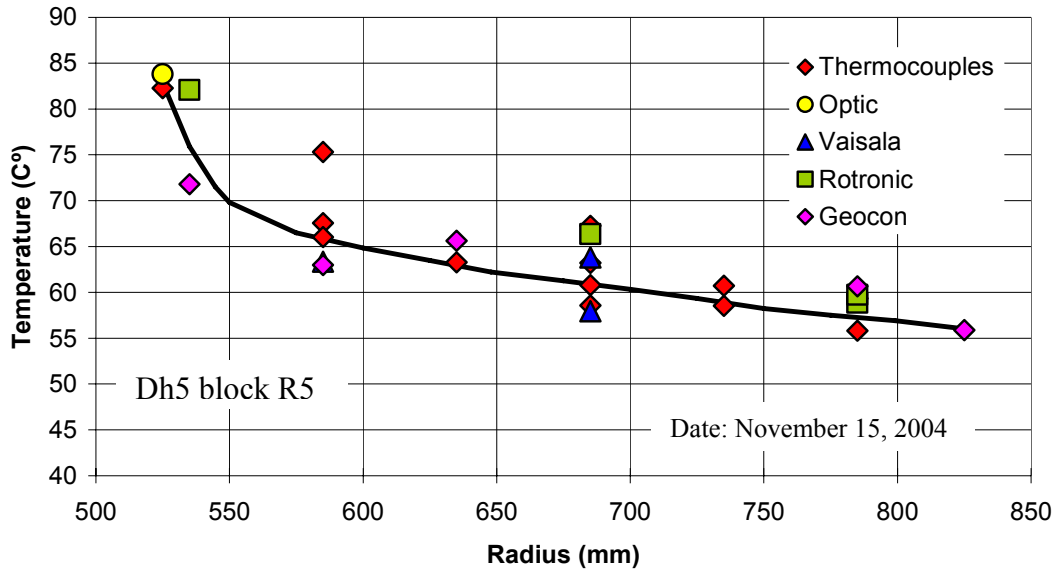

Figure 7-2. The temperature in block R5 in Dh 5 as function of radius from the centre of the deposition hole on November 15, 2004.

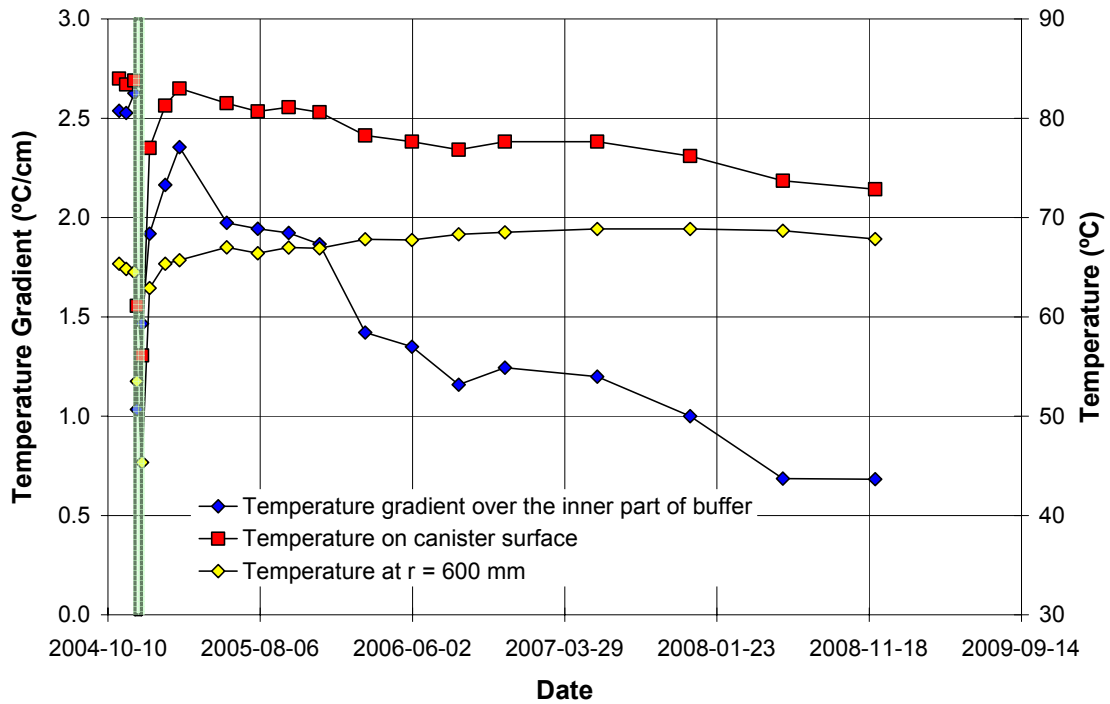

Figure 7-3. The temperature and temperature gradient over the inner par of the buffer plotted as function the date in deposition hole 5 block R5.

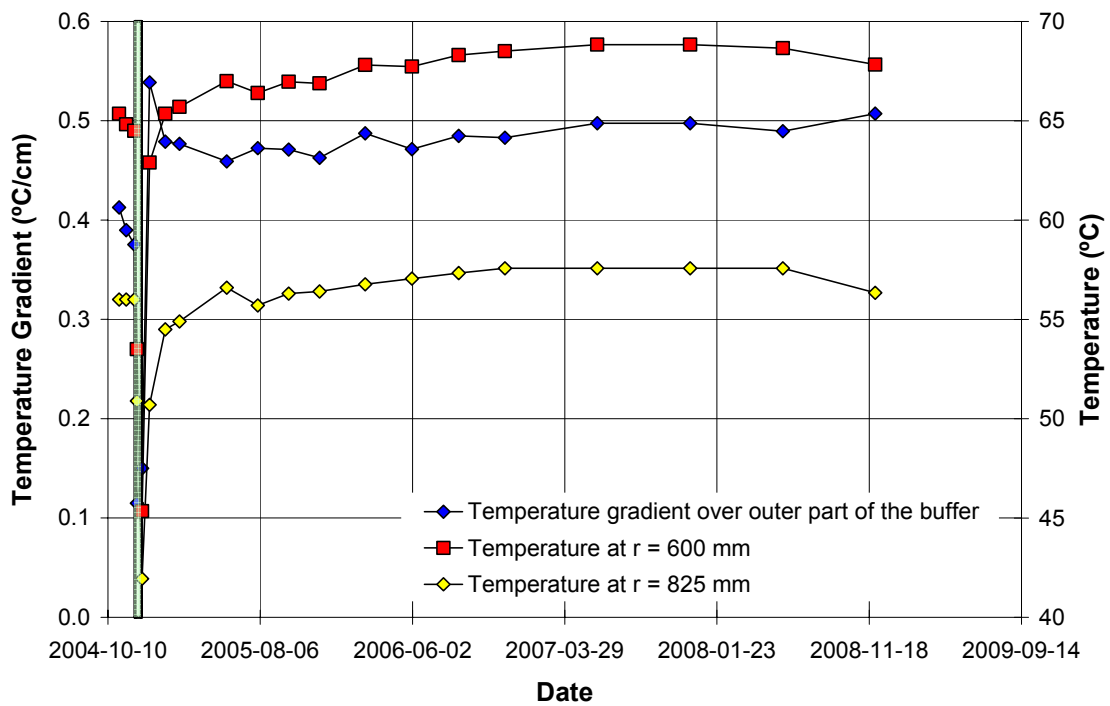

Figure 7-4. The temperature and temperature gradient over the outer par of the buffer plotted as function the date in deposition hole 5 block R5.

7.6.2 Deposition hole 6

The saturation of the buffer in deposition hole 6 was affected by the quick increase in pressure when the drainage of the tunnel was closed, indicated by both RH sensors and total pressure sensors. The total pressure was also affected when the power was switched off again at the beginning of September 2005. The drop in total pressure was very large and rapid and the pressure started to increase before the power to the canister was switched on again. When the power was switched on the pressure increased very fast to the same level as before the power was switched off. This course of events is indicating that the change in total pressure is an effect of the changes in water volume in the bentonite caused by variation in temperature.

The temperature in the buffer for deposition hole 6 is plotted as function of the radial distance from the centre of the deposition hole at mid height of the canister in Figure 7-5 at November 15, 2004 which was before the high pore pressure in the tunnel was observed. Compared to the corresponding plots for deposition hole 5 these plots indicate a drop in temperature between the surface of the canister and the buffer (inner diameter of the ring). The temperature on the canister surface measured with the optical system is also rather high compared to measurements made on canister 1. The measurements indicate that the initial slot between the buffer and the canister of about 10 mm was still open when the drainage was closed. Corresponding plot of the temperature some time after the drainage was opened again shows that the temperature on the surface of the canister has dropped with about 10 °C, see Figure 7-6.

The temperature gradient over the inner slot is shown in Figure 7-7 as function of time. The shaded parts of the plot represents the time when the power to the canister was switched off. The plot shows that both the temperatures and the temperature gradient were affected very much by the closing/opening of the drainage which is indicating that the inner slot was closed when water entered the slot. The temperatures and the gradient were also affected when the power to the canister was switched off for the second time. Both the temperatures and the gradient have reached the same levels as before the power was switched off the second time. The measured temperatures in the buffer were also affected by the two reduction of the power to the canister with about 200 W and 300 W due to problems with the installed heaters. Many of the sensors installed close to the canister surface have recently stopped giving reliable values and the temperature on the canister and the gradient over the inner part of the buffer are thus less accurate.

The closing of the gap is also affecting the temperature development in different part of the buffer since the relation between the heat leaving the end parts of the canister and the heat leaving the cylindrical part of the canister was changed when the gap was closed. Directly after the installation, the buffer was in good contact with the ends of the canister while the slot was isolating the rest of canister surface from the buffer. When the gap was closed, more of the generated heat was leaving the cylindrical part of the canister resulting in a higher temperature in the buffer at the central part of the deposition hole and a lower temperature in the buffer at the ends of the canister.

The temperature gradient over the outer part of the buffer is plotted in Figure 7-8. This gradient was also affected when the power was switched off. After the power was switched on again this gradient was stabilized on the same level as before the power was switched off. Due to the reduction of the power to the canister, both the temperature and the temperature gradient over the buffer decreased.

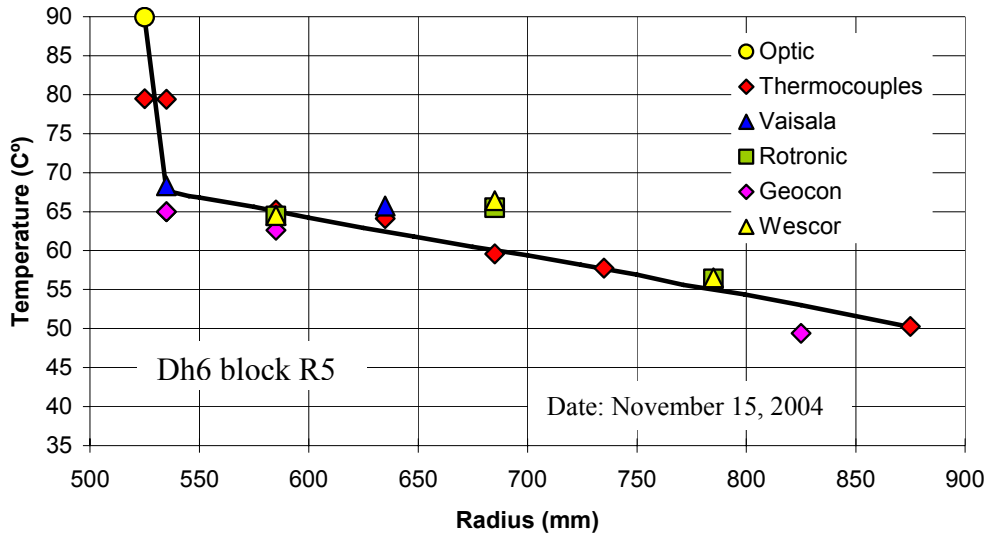

Figure 7-5. The temperature in block R5 in Dh 6 as function of radius from the centre of the deposition hole on November 15, 2004.

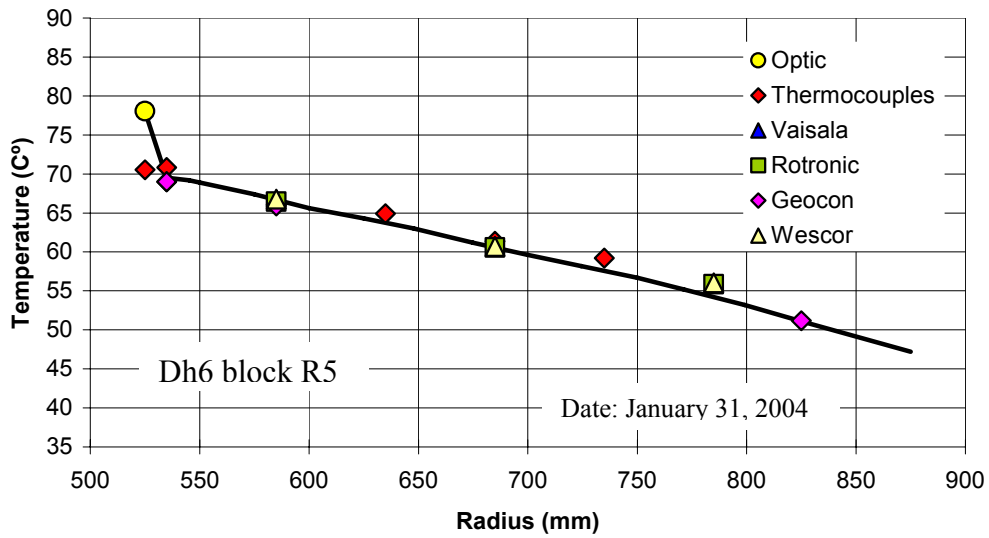

Figure 7-6. The temperature in block R5 in Dh 6 as function of radius from the centre of the deposition hole on January 31, 2005.

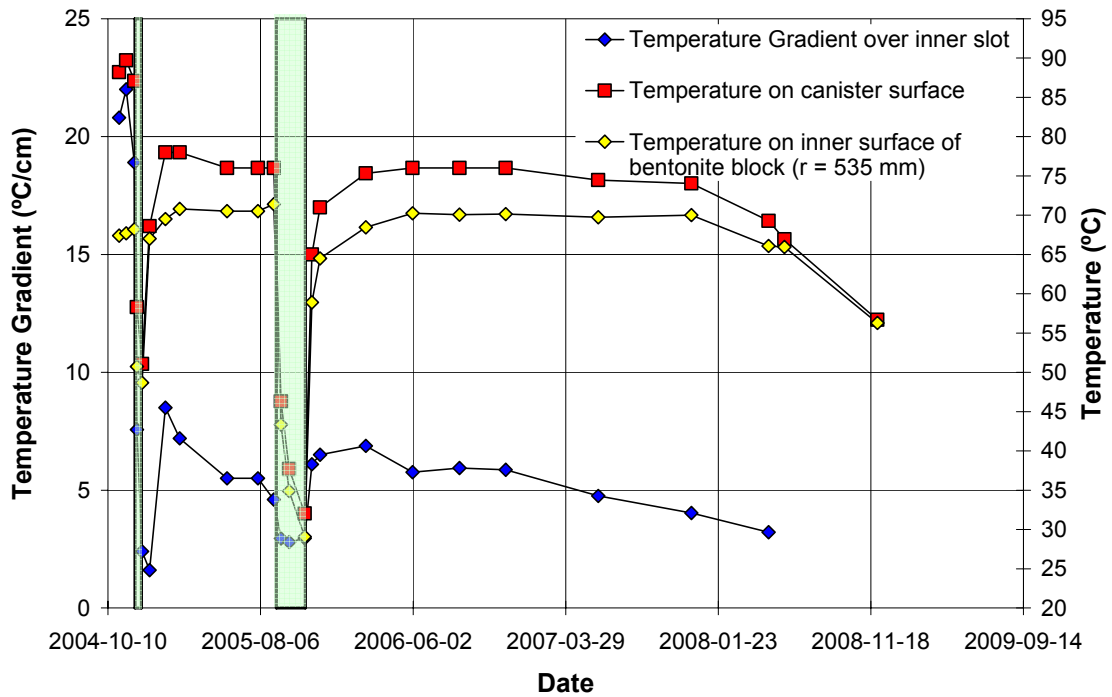

Figure 7-7. The temperature and temperature gradient over the inner slot plotted as function the date in deposition hole 6 block R5.

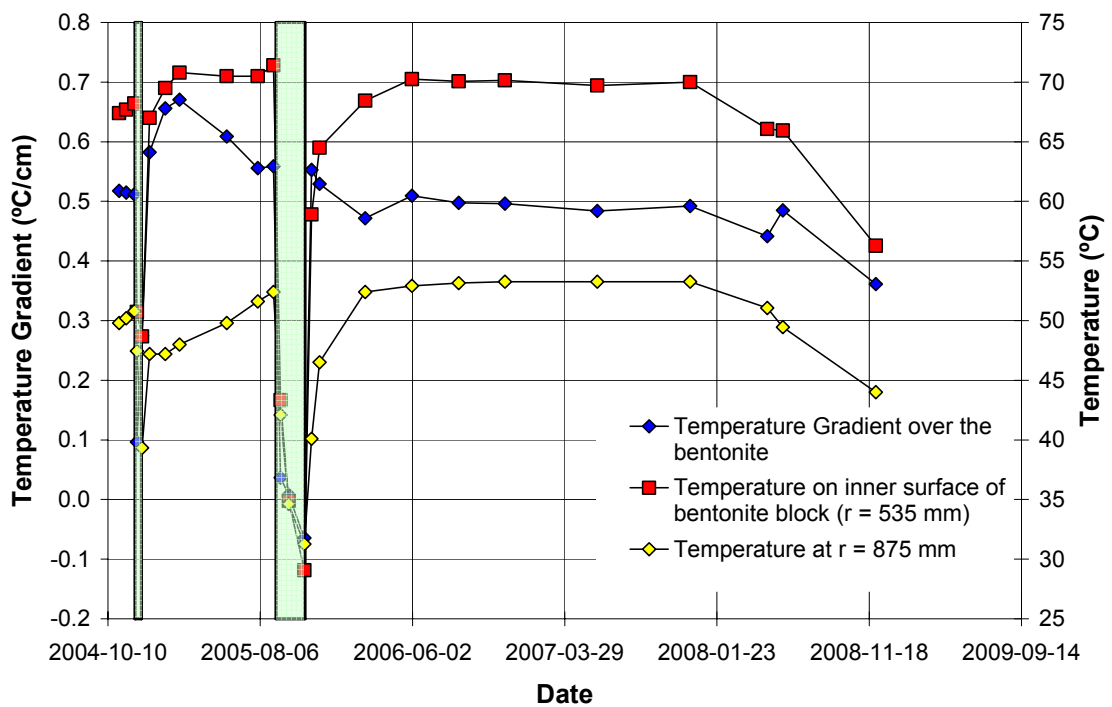

Figure 7-8. The temperature and temperature gradient over the buffer plotted as function the date in deposition hole 6 block R5.

7.6.3 Backfill

The pore pressure, measured both with total and pore pressure transducers placed in the backfill, increased fast from a low level when the drainage of the tunnel was closed. This affected the rate in which the backfill was saturated measured both with soil psychrometers and with resistivity measurements in the backfill. After the drainage was opened again the pore pressure stabilized on a higher level than before the drainage was closed. Both the total pressure and the water pressure are continuing to increase although the drainage is kept open. The outflow from the drainage of the outer section is plotted in Figure 7-9. During this measuring period most of the pore pressure and total pressure sensors are indicating an increase in pressure. Most of the installed soil psychrometers measure very low suction values after the closing/opening of the drainage witch indicate that the backfill is close to fully saturated.

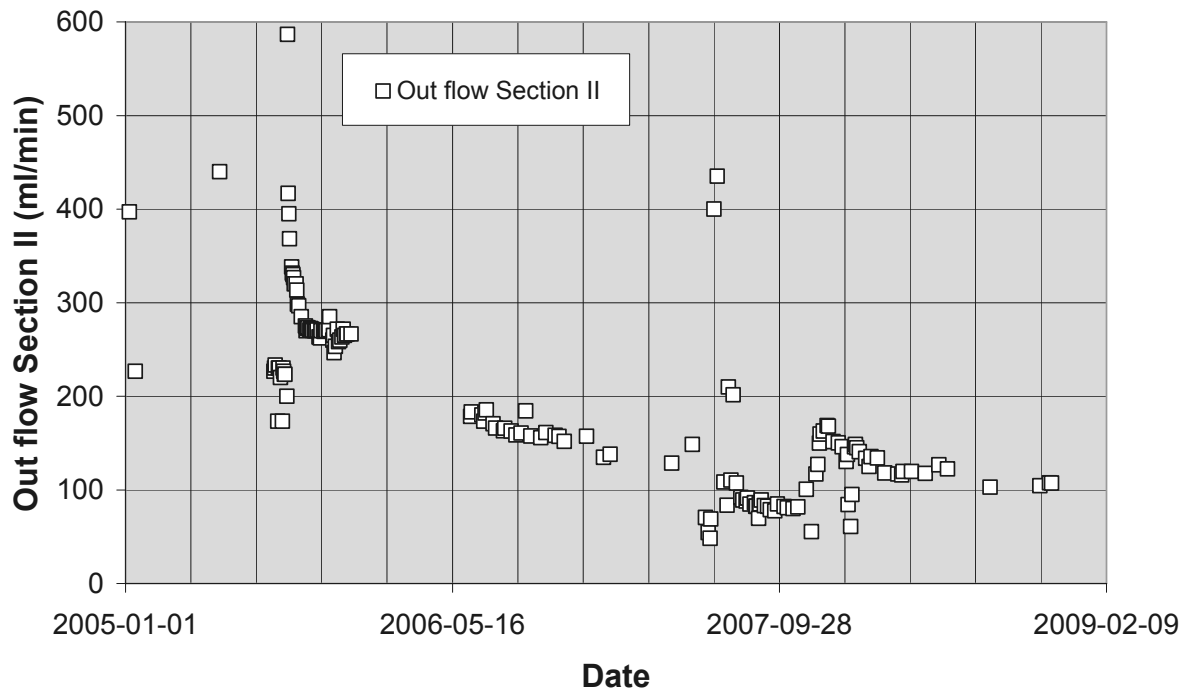

Figure 7-9. The measured outflow from the outer section of the Prototype tunnel.

8 References

/1-1/ **Börgesson L, Sanden T.** Report on instrument positions and preparation of bentonite blocks for instruments and cables in section 1, February 2001. SKB IPR-01-20

/2-1/ **Börgesson L, Sanden T.** Instrumentation of buffer and backfill in Section 2, January 2003. SKB IPR-03-21

Appendix 1

Dep. hole 1

Prototype\Hole 1\Cyl.1 (010917-081201)
Total pressure - Geokon

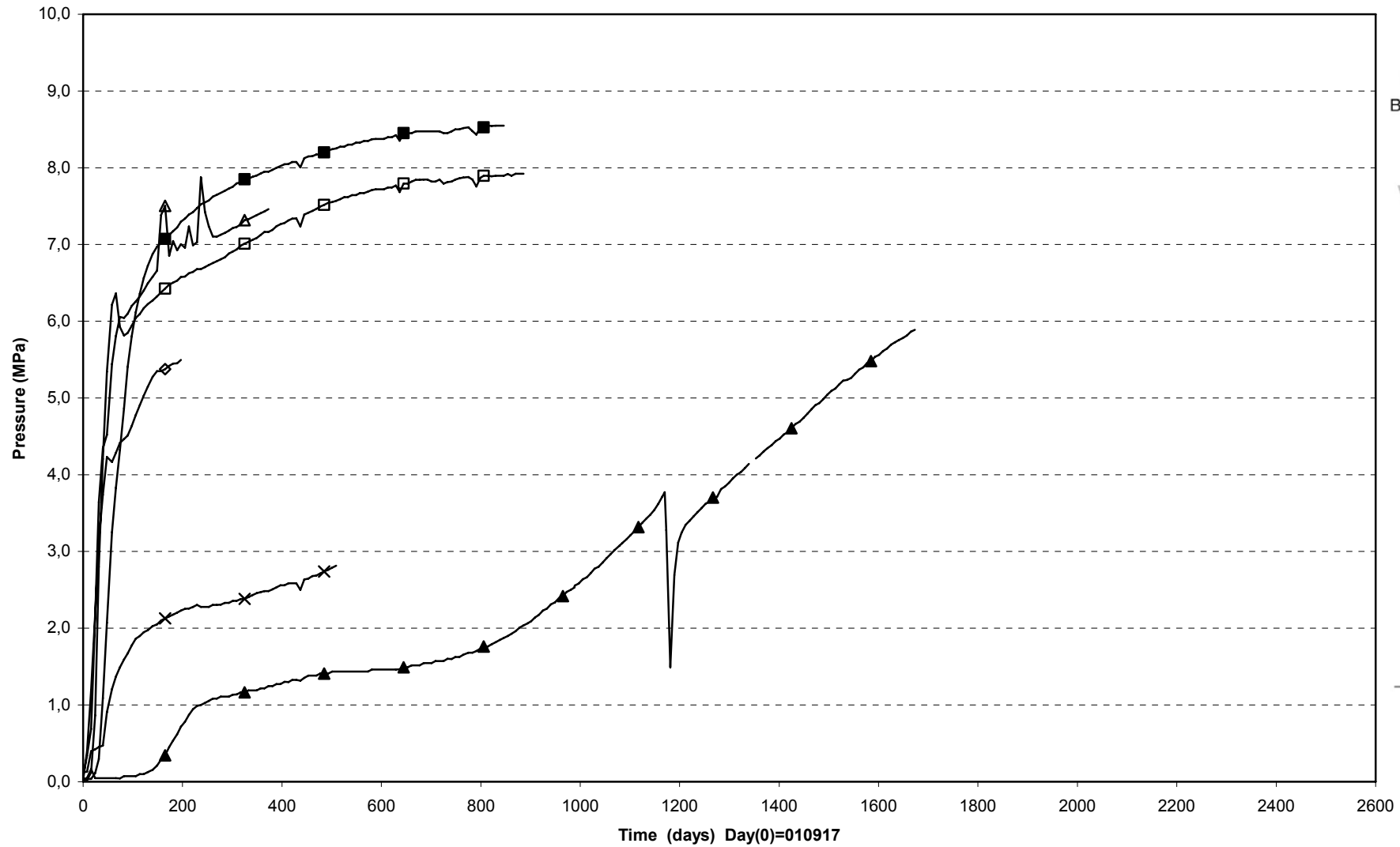

× PBU10001(0°\0°) ▲ PBU10002(0.504\0°\0.100) ◇ PBU10008(0.504\185°\0.635) △ PBU10006(0.504\95°\0.635)
 □ PBU10007(0.504\105°\0.735) ■ PBU10009(0.504\195°\0.735)

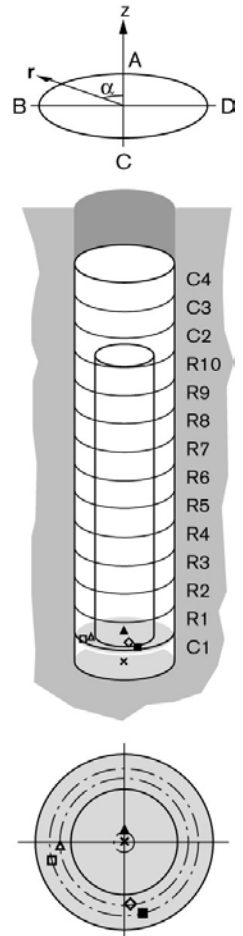

Prototype\Hole 1\Ring5 (010917-081201)
 Total pressure - Geokon

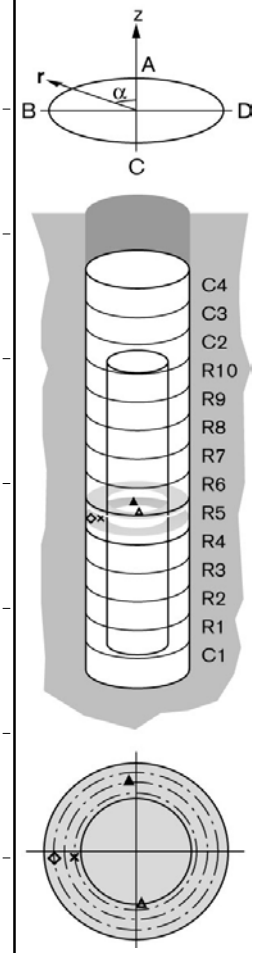
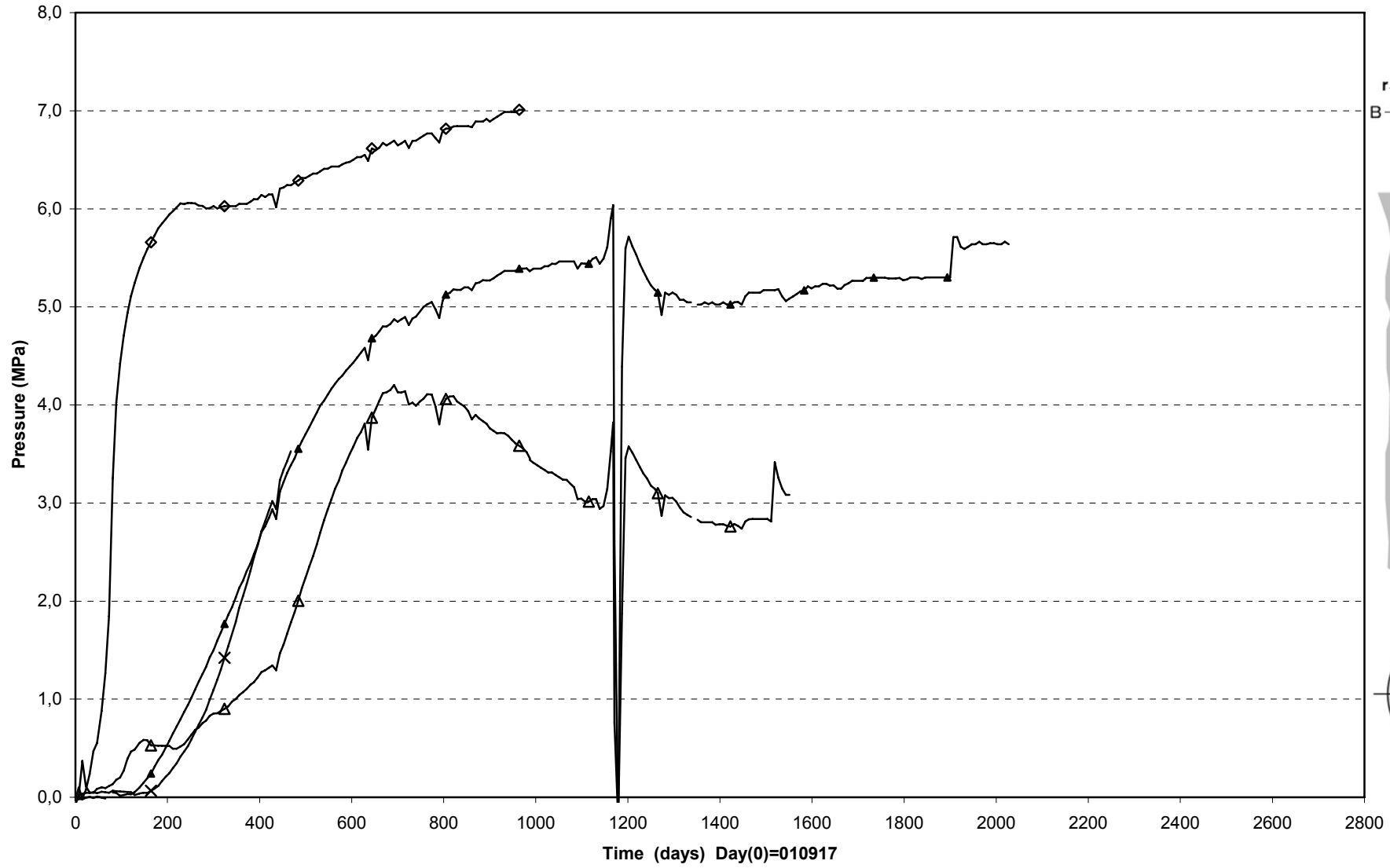

× PBU10013(2.780\95°\0.585) ▲ PBU10011(2.780\5°\0.685) ◊ PBU10014(2.780\95°\0.785) Δ PBU10015(3.030\185°\0.535)

Prototype\Hole 1\ Ring10 and Cyl.3 (010917-081201)
 Total pressure - Geokon

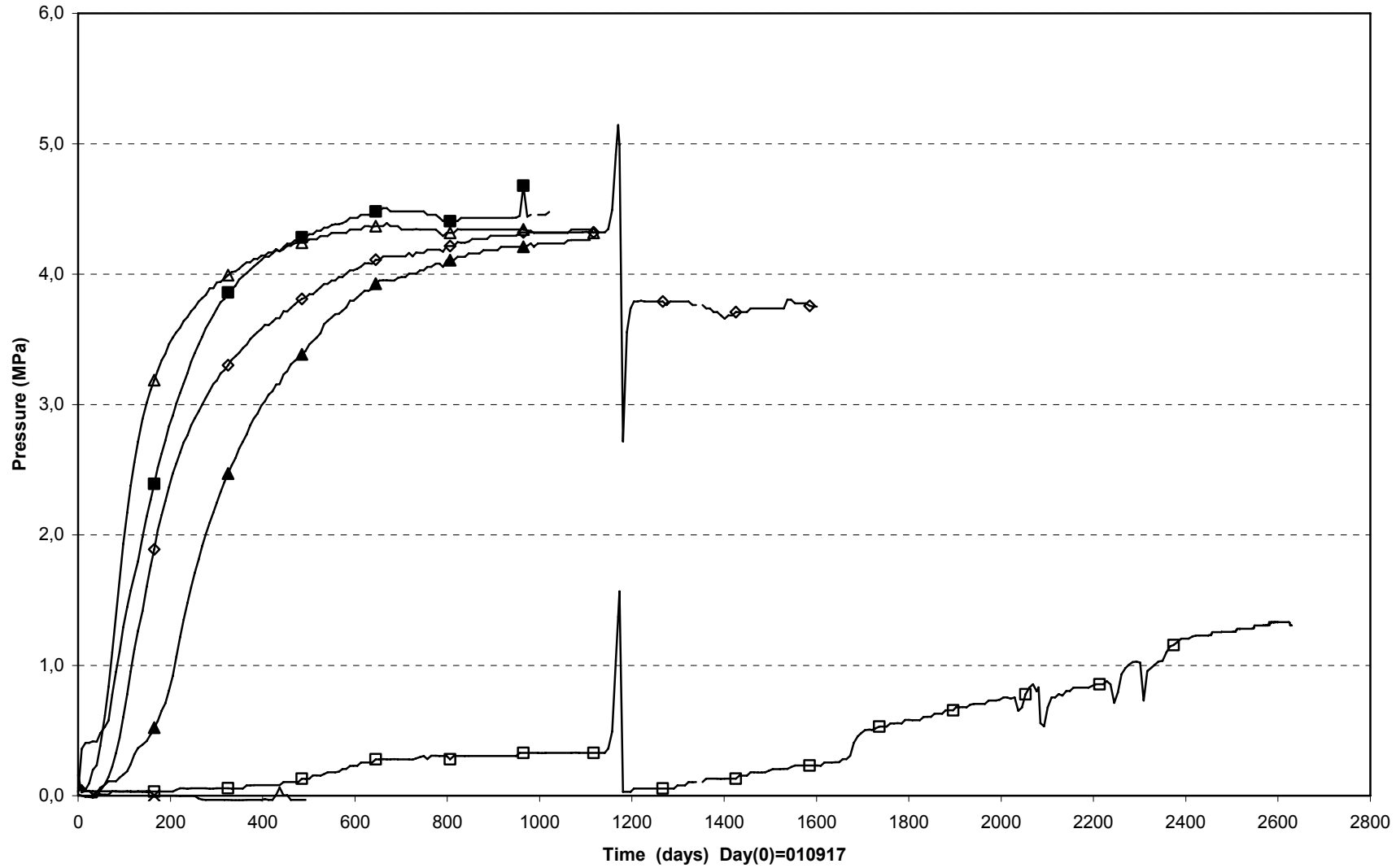

× PBU10017(5.558\0°\0.050)	▲ PBU10021(5.558\90°\0.635)	◇ PBU10022(5.558\100°\0.735)	△ PBU10023(5.558\190°\0.735)
□ PBU10026(6.567\5°\0.585)	■ PBU10024(5.558\180°\0.635)		

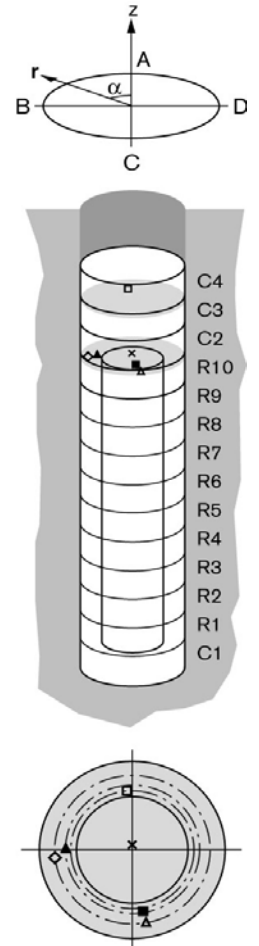

Prototype\ Hole 1 (010917-081201)
 Total pressure - Kulite

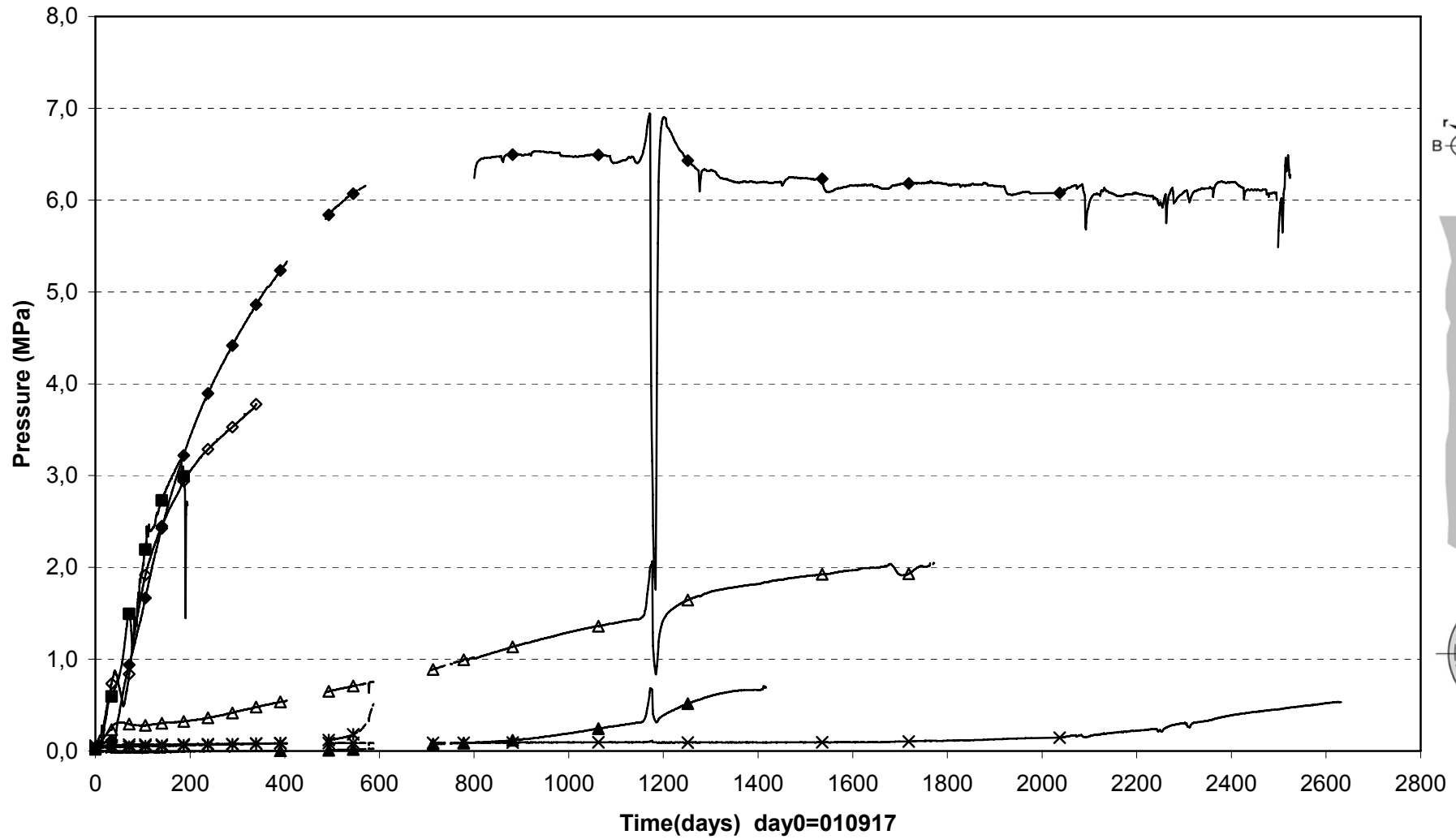

■ PBU10004(0.504\5°\0.685) ◇ PBU10005(0.504\5°\0.785) ◆ PBU10012(3.030\5°\0.785) ▲ PBU10019(5.558\5°\0.685)
 △ PBU10020(5.558\5°\0.785) × PBU10025(6.317\0°\0.050) * PBU10027(7.076\0°\0.050)

Prototype\Hole 1\Cyl.1 (010917-081201)
Relative humidity - Vaisala

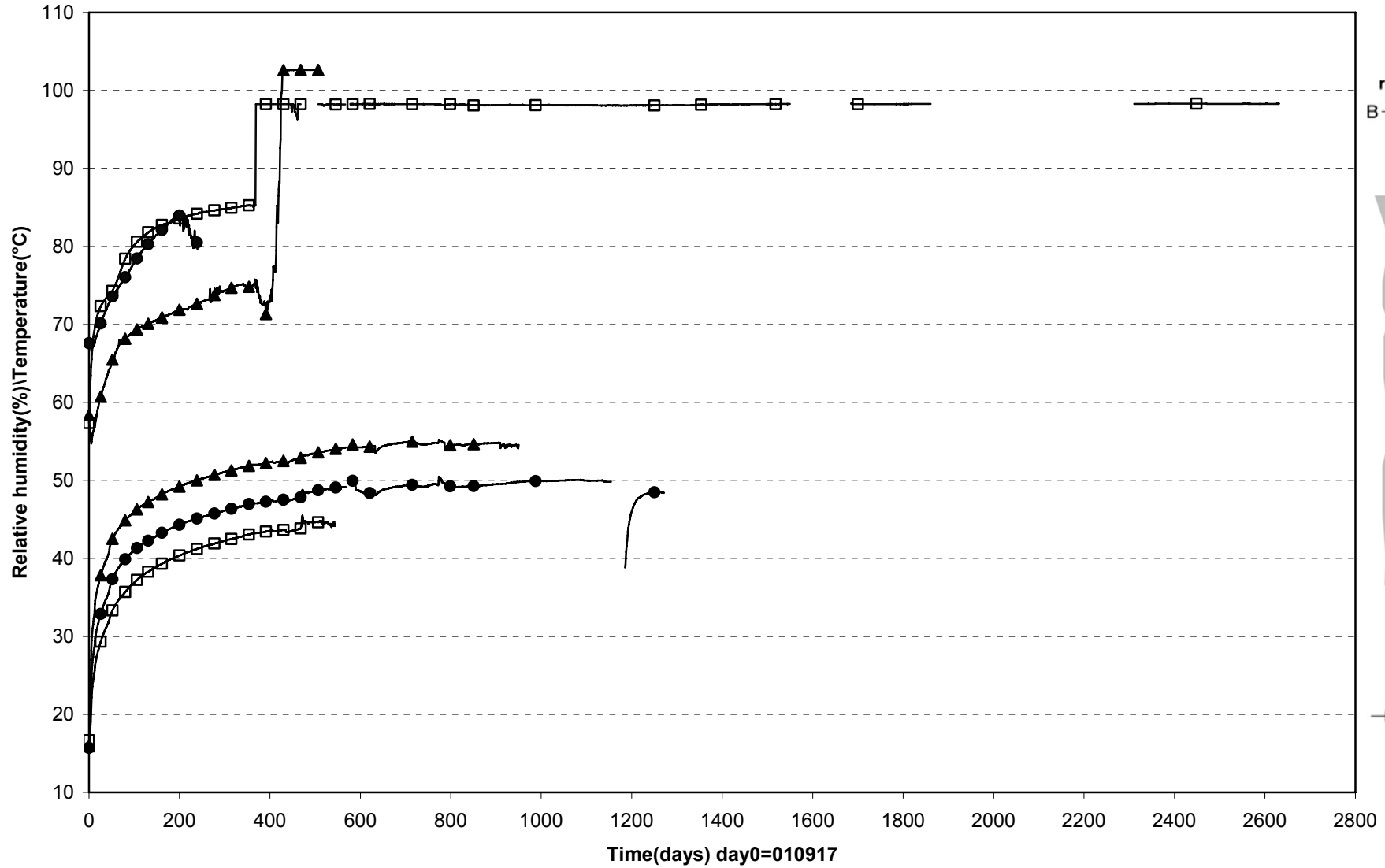

□ WBU10004(0.344\350°\0.785) ● WBU10005(0.344\350°\0.685) ▲ WBU10006(0.344\350°\0.585)

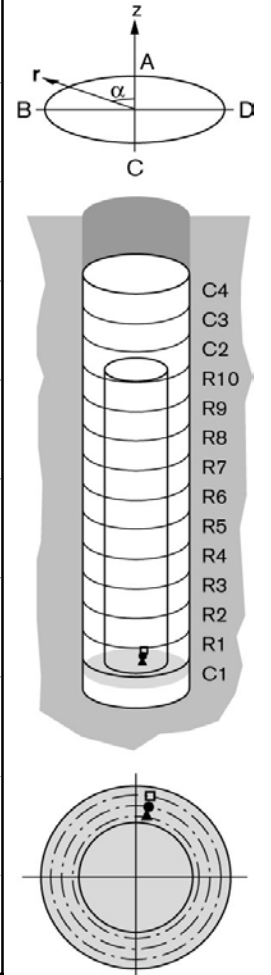

Prototype\Hole 1\Ring.5 (010917-081201)
 Relative humidity - Vaisala

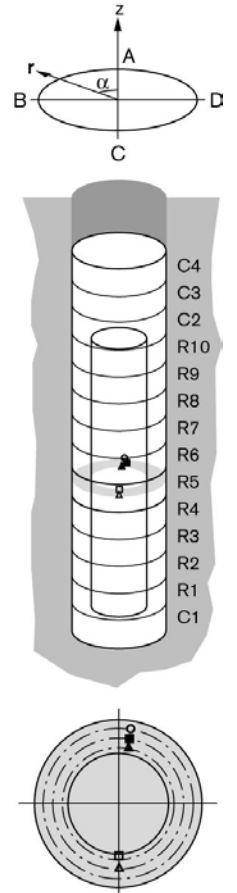
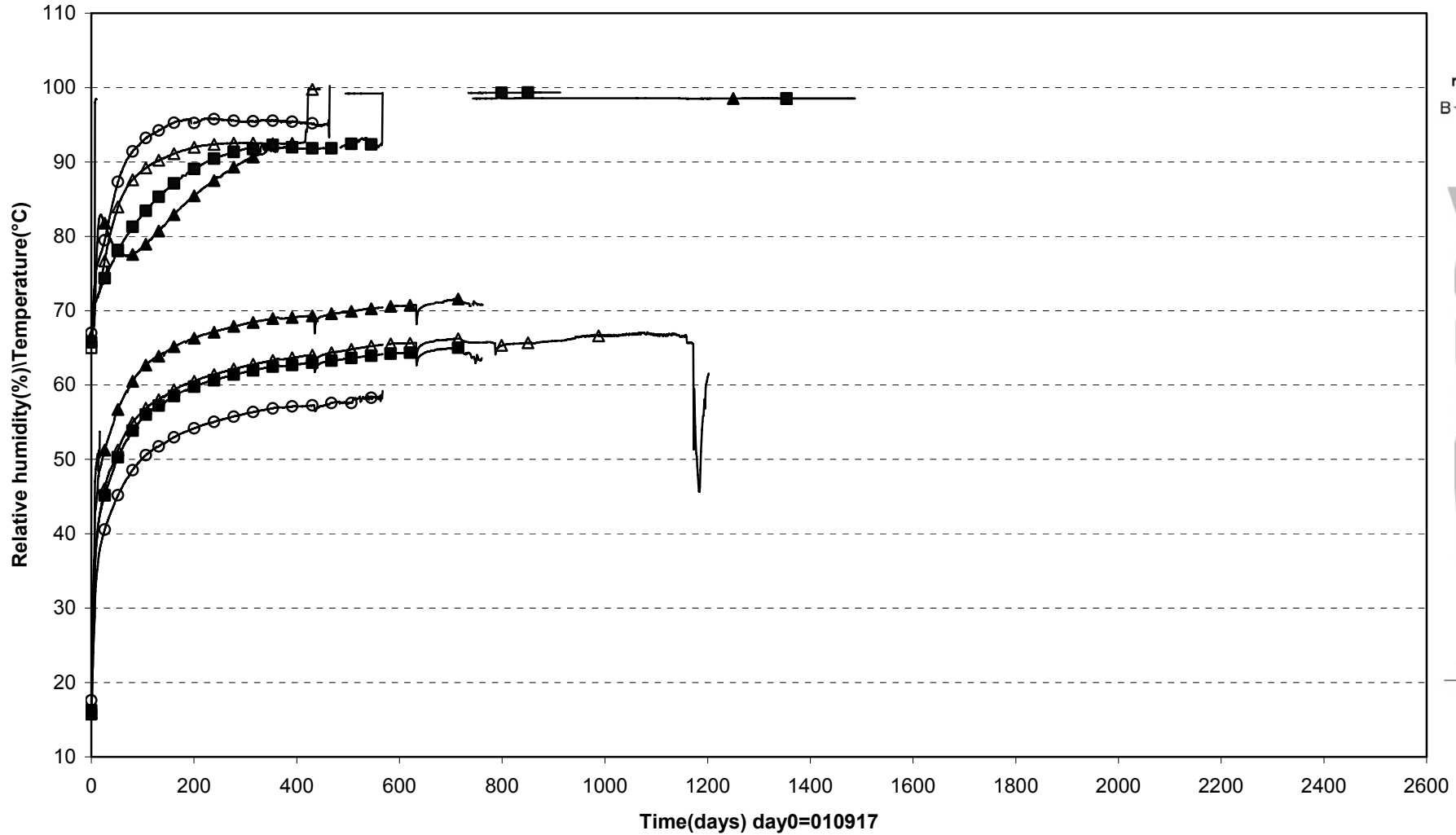

▲ WBU10013(2.870\350°\0.585)	■ WBU10014(2.870\350°\0.685)	○ WBU10015(2.870\350°\0.785)
□ WBU10019(2.870\180°\0.535\In the slot)	△ WBU10020(2.870\180°\0.685)	

Prototype\Hole 1\Ring10 (010917-081201)
Relative humidity - Vaisala

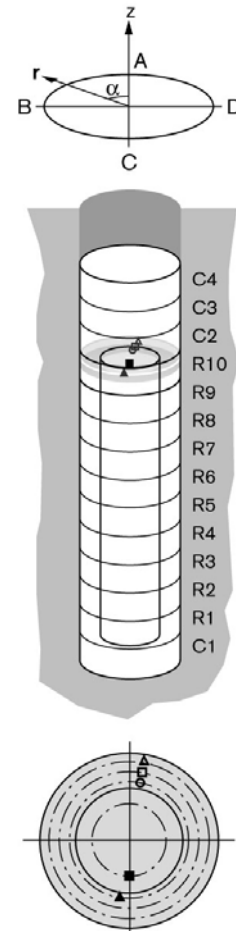
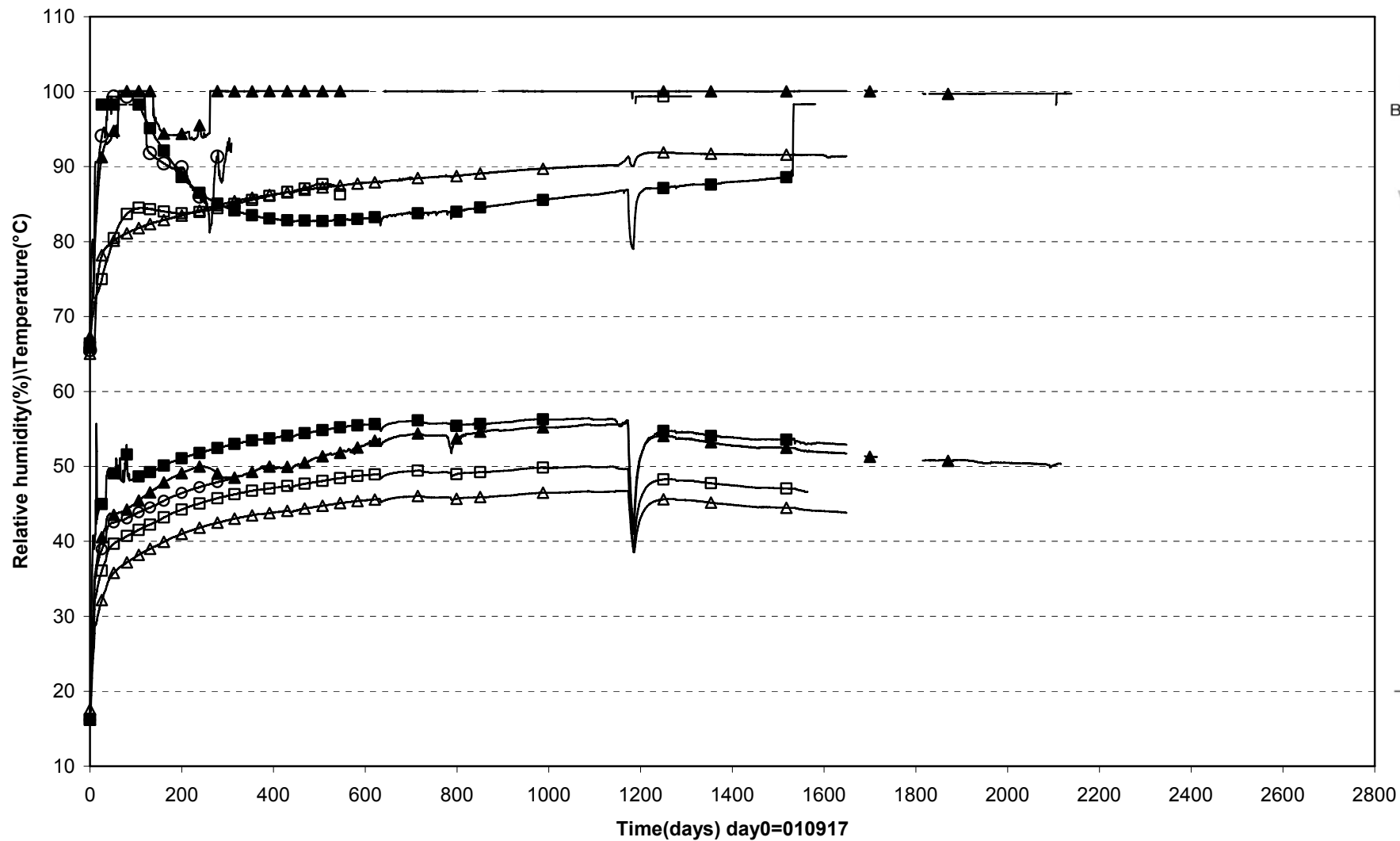

■ WBU10023(5.428\180°\0.362) ○ WBU10024(5.398\350°\0.585) □ WBU10025(5.398\350°\0.685) △ WBU10026(5.398\350°\0.785) ▲ WBU10030(5.398\170°\0.585)

Prototype\Hole 1\Cyl.3 and Cyl.4 (010917-081201)
Relative humidity - Vaisala

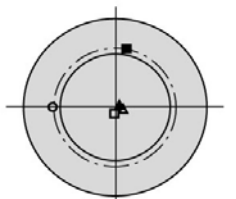
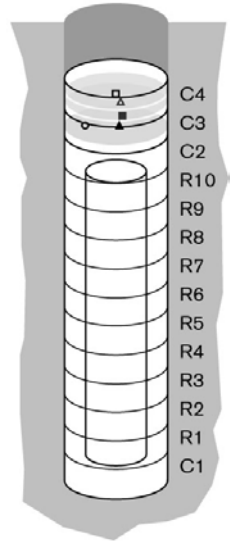
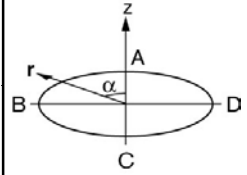
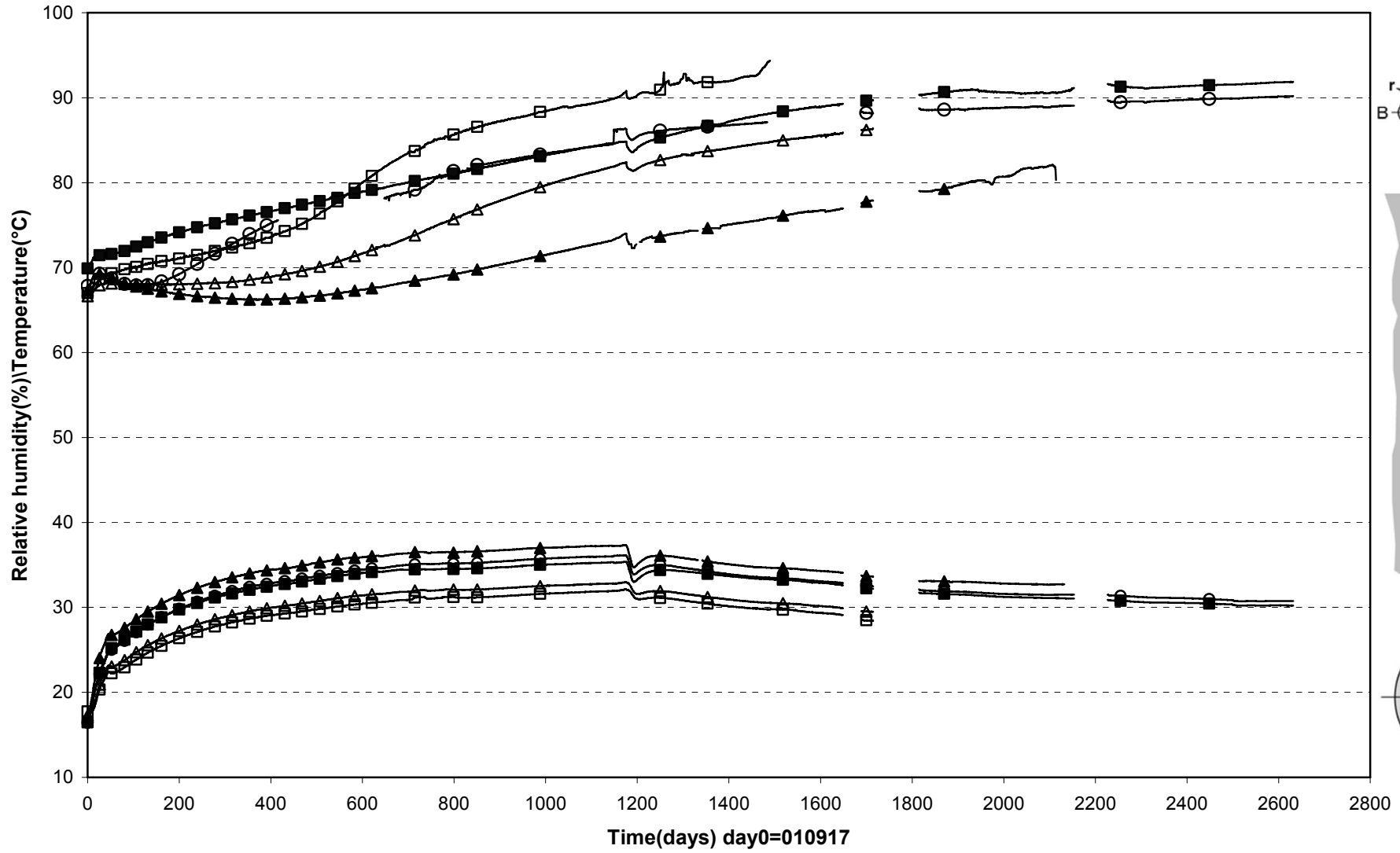

▲ WBU10032(6.317\270°\0.050) ■ WBU10033(6.317\350°\0.585) ○ WBU10034(6.317\90°\0.585) □ WBU10036(6.916\180°\0.050) △ WBU10037(6.756\270°\0.050)

Prototyp\Hole 1\Cyl.1 (010917-081201)
Relative humidity - Rotronic

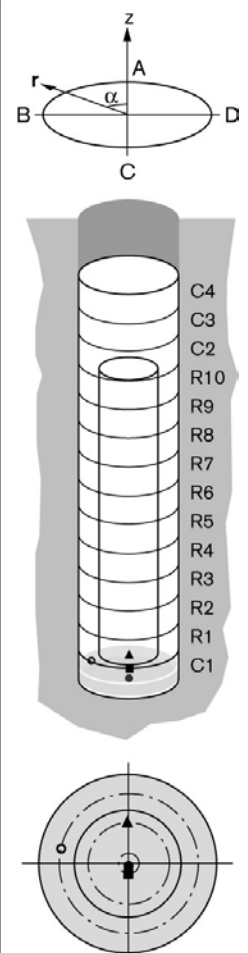
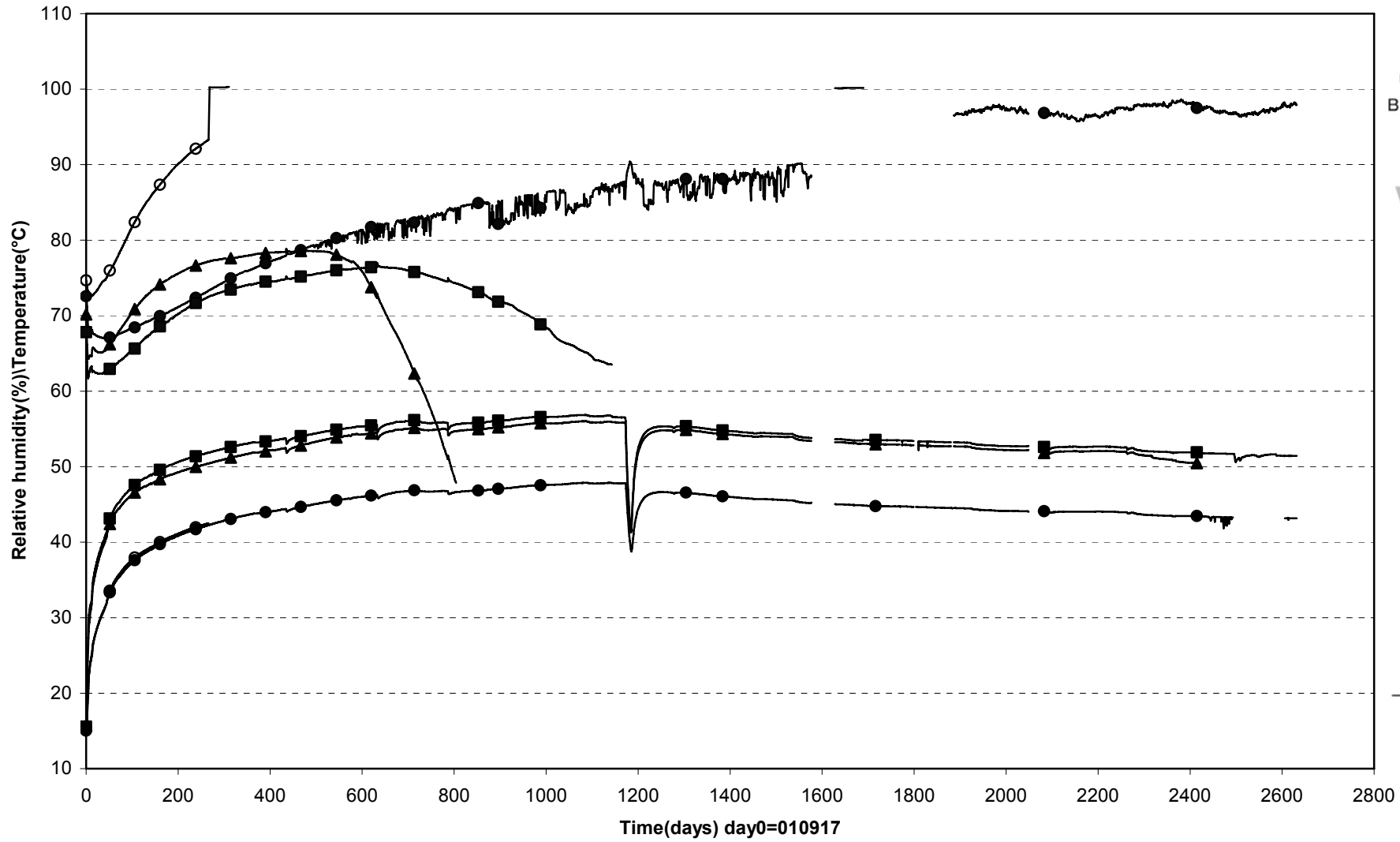

Prototyp\Hole 1\Cyl.1 (010917-081201)
Relative humidity - Rotronic

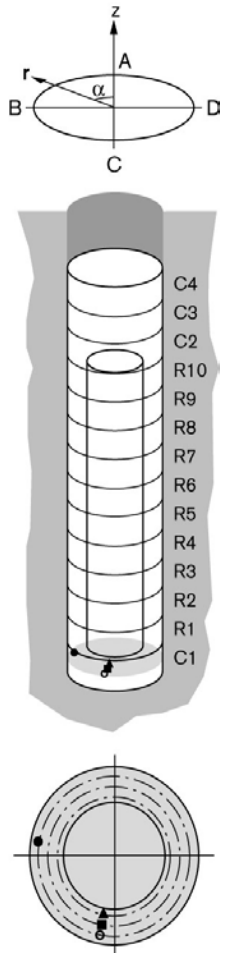
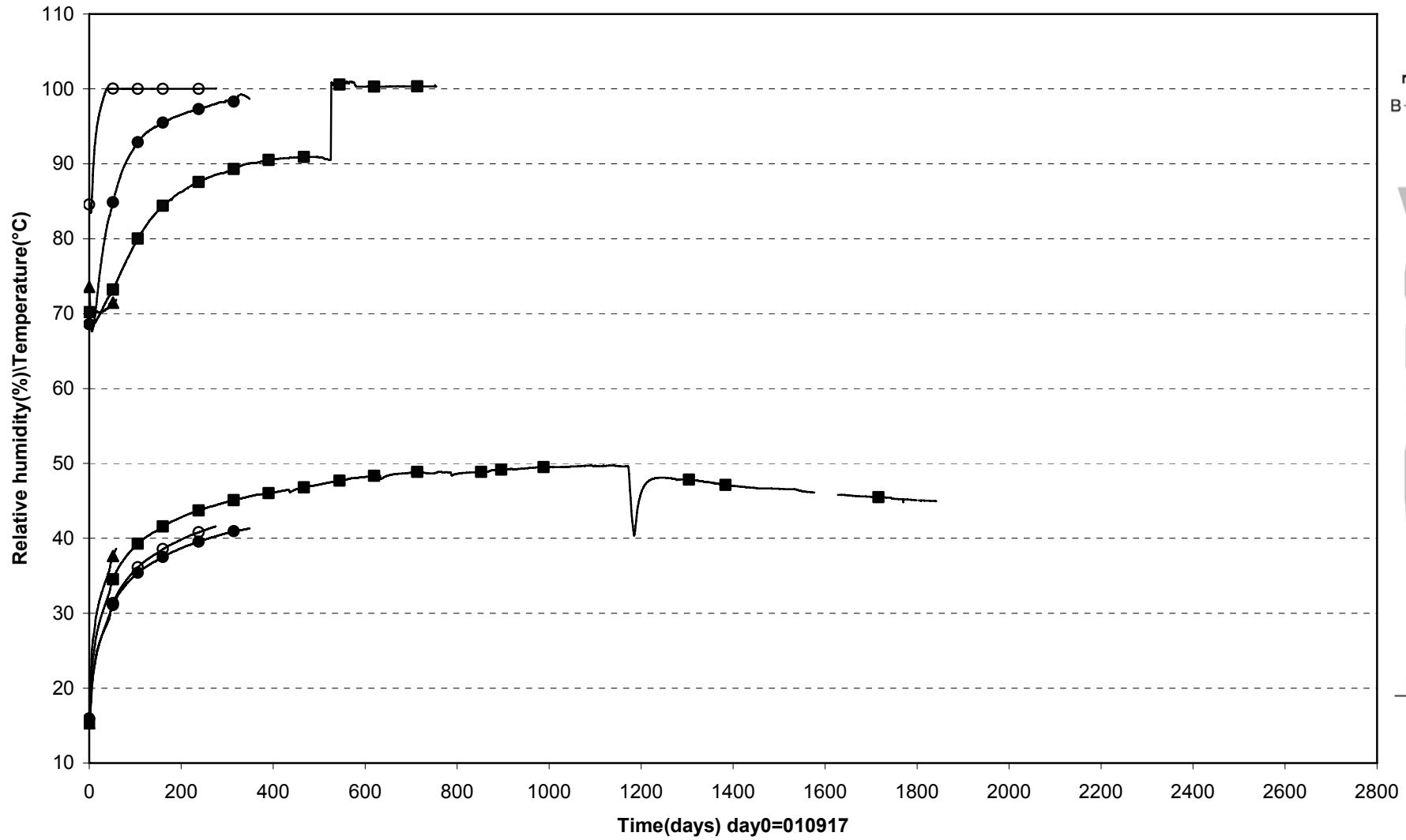

● WBU10009(0.254\80°\0.785) ▲ WBU10010(0.254\170°\0.585) ■ WBU10011(0.254\170°\0.685) ○ WBU10012(0.254\170°\0.785)

Prototyp\Hole 1\Ring.5 (010917-081201)
 Relative humidity - Rotronic

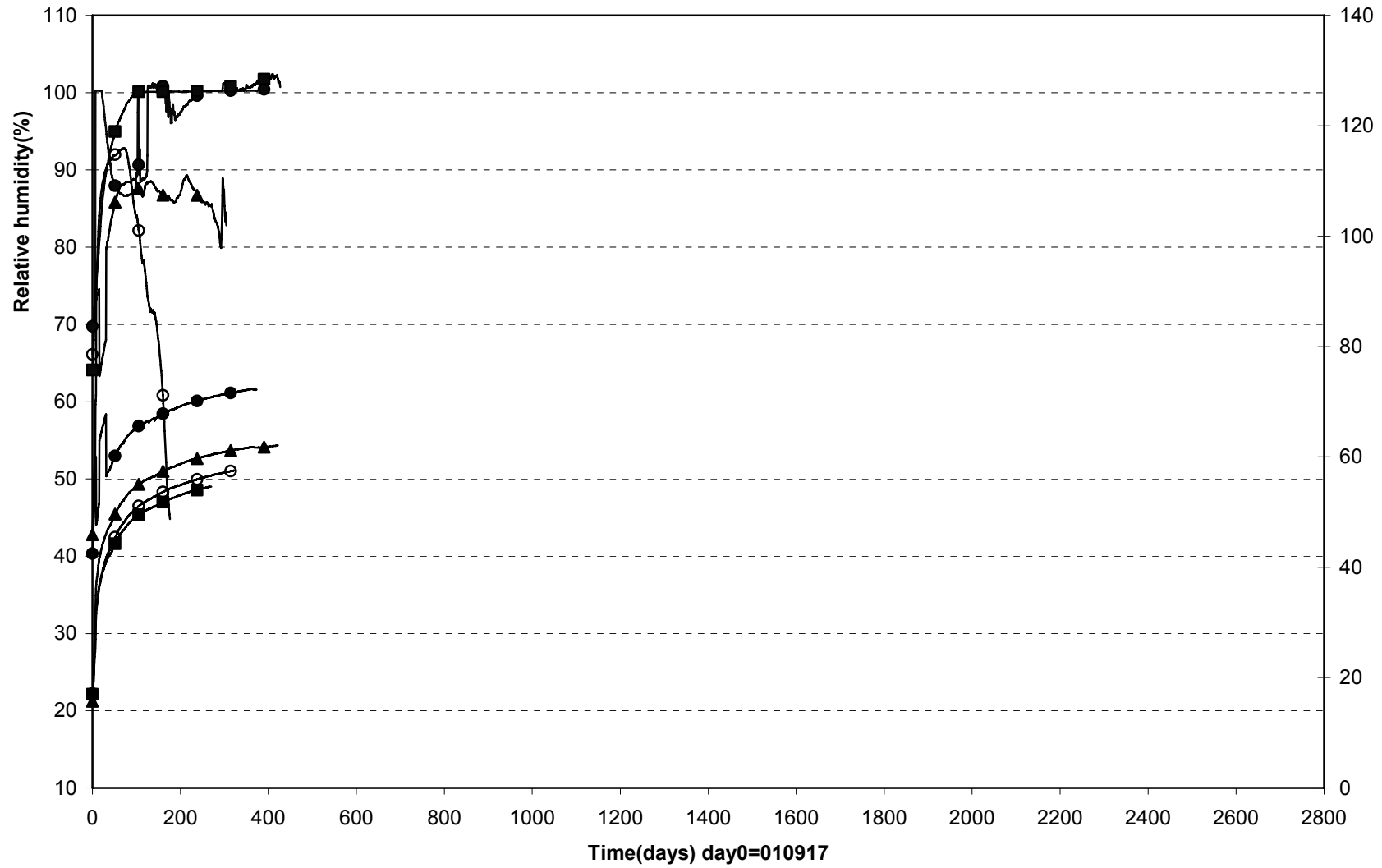

● WB10016(2.780\80°\0.535) ▲ WB10017(2.780\80°\0.685) ■ WB10018(2.780\80°\0.785) ○ WB10021(2.780\180°\0.785)

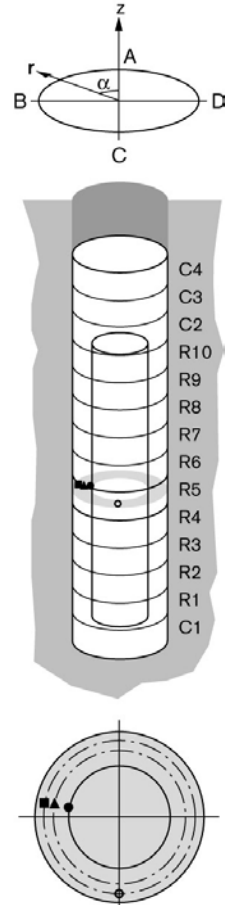

Prototyp\Hole 1\Ring10 (010917-081201)
Relative humidity - Rotronic

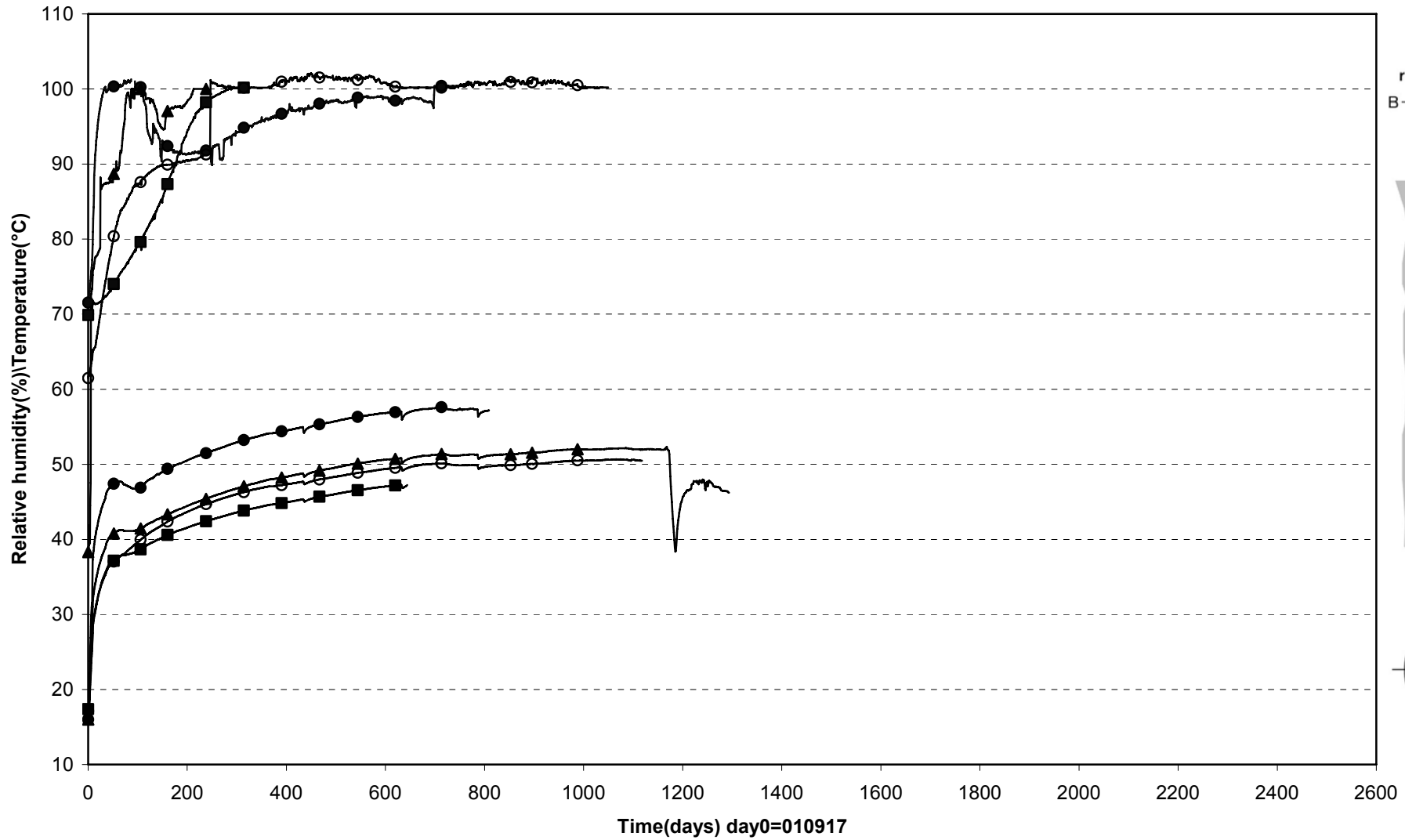

● WBU10027(5.308\80°\0.585) ▲ WBU10028(5.308\80°\0.685) ■ WBU10029(5.308\80°\0.785) ○ WBU10031(5.308\170°\0.785)

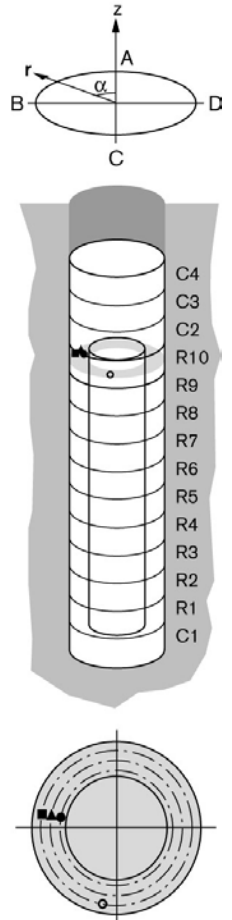

Prototyp\Hole 1\Cyl.3 (010917-081201)
 Relative humidity - Rotronic

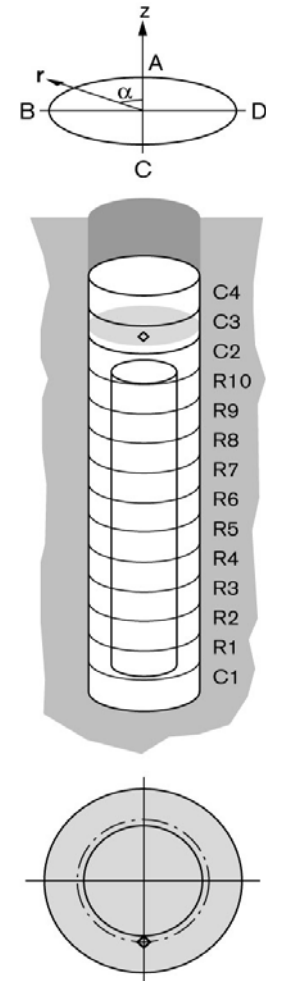
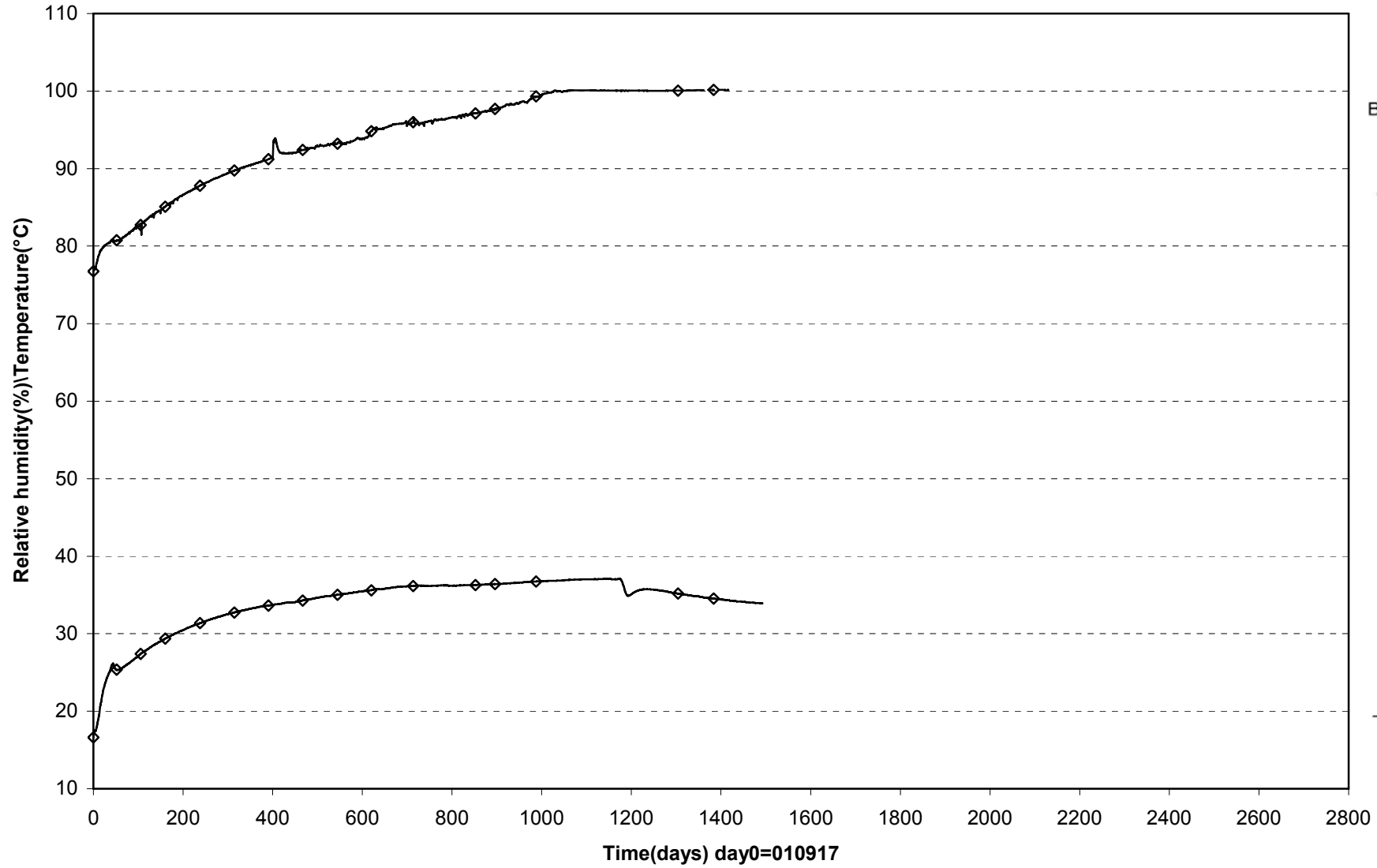

◇ WB10035(6.317\180°\0.585)

PrototypeHole 1 (010917-081201)
Pore pressure - Geokon

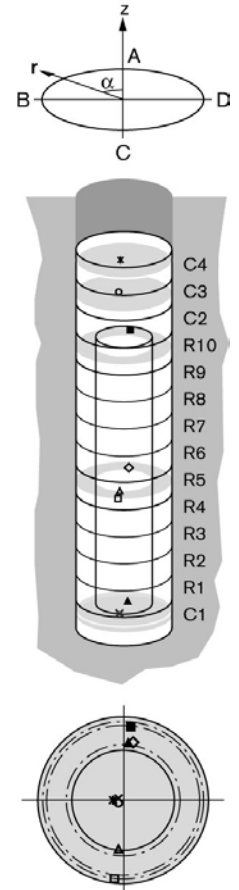
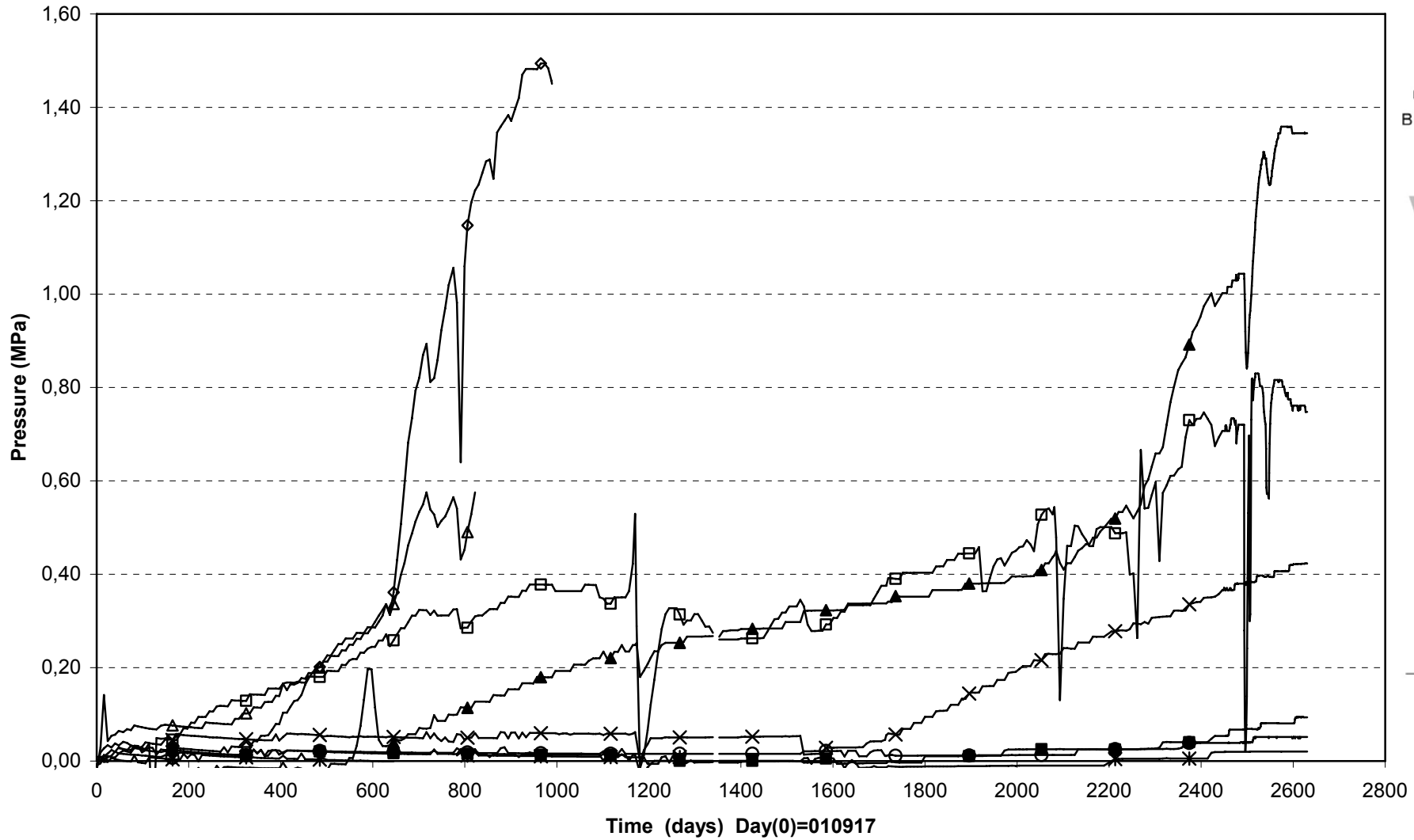

- | | | | |
|------------------------------|------------------------------|------------------------------|------------------------------|
| × UBU10002(0.254\90°\0.100) | ▲ UBU10003(0.344\355°\0.585) | ◇ UBU10005(2.780\355°\0.585) | △ UBU10009(2.780\175°\0.535) |
| □ UBU10010(2.780\175°\0.825) | ■ UBU10012(5.308\355°\0.785) | ○ UBU10013(6.317\90°\0.050) | ✱ UBU10014(6.916\90°\0.050) |

Prototype\ Hole 1 (010917-081201)
Pore pressure - Kulite

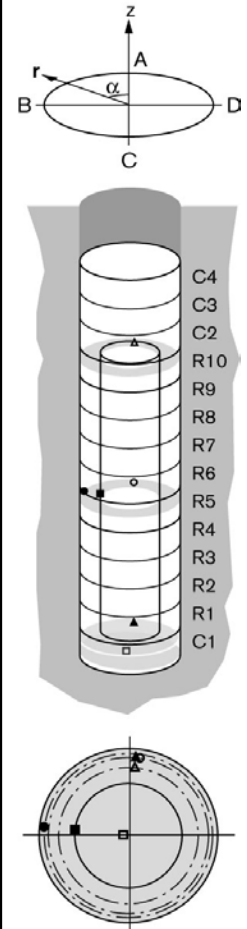
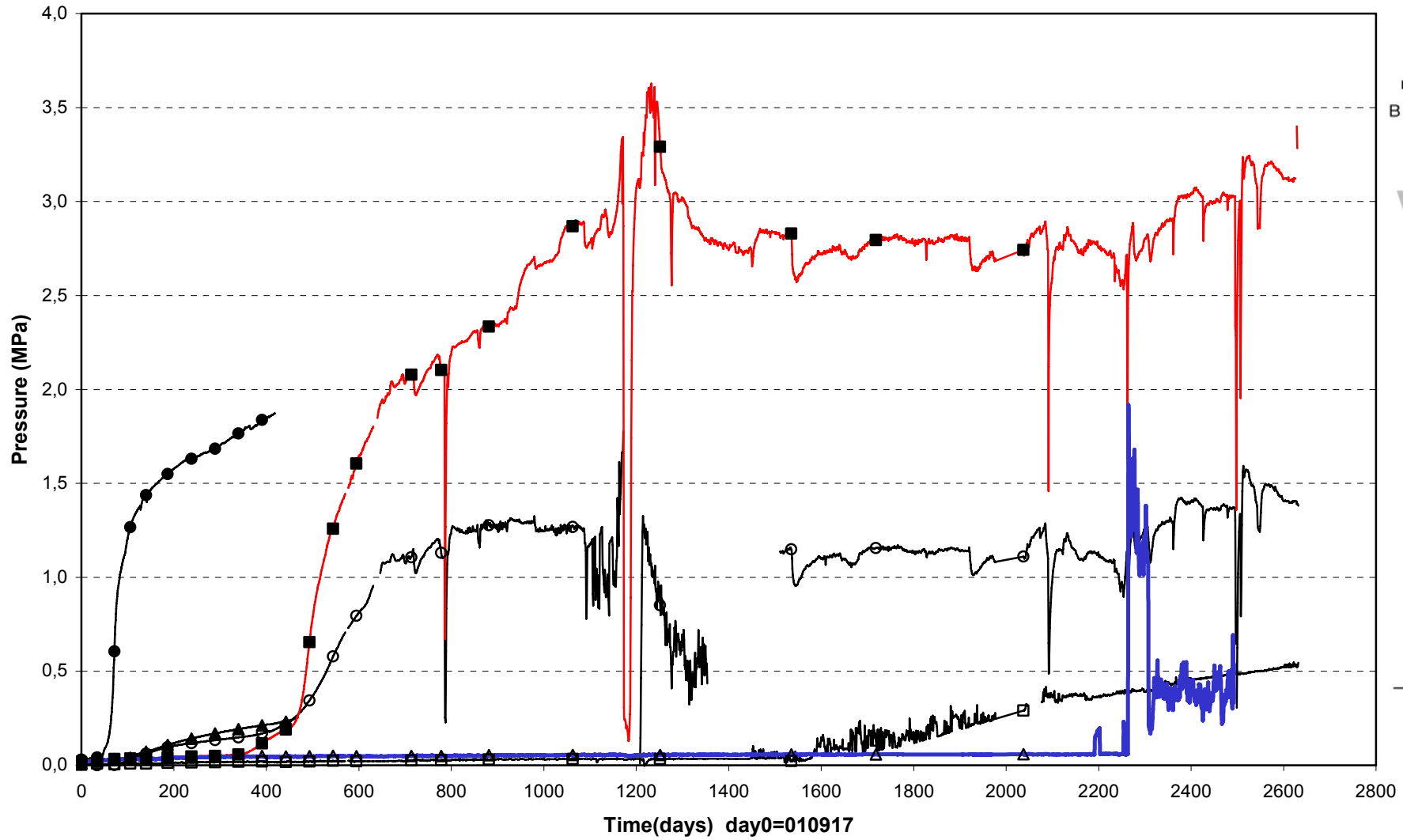

□ UBU10001(0.054\90°\0.050)	▲ UBU10004(0.344\355°\0.785)	○ UBU10006(2.870\355°\0.785)
■ UBU10007(2.870\85°\0.535\In the slot)	● UBU10008(2.870\85°\0.825\In the slot)	△ UBU10011(5.398\355°\0.585)

Prototype\Hole 1\Cyl.1 (010917-081201)
 Temperature - Pentronic

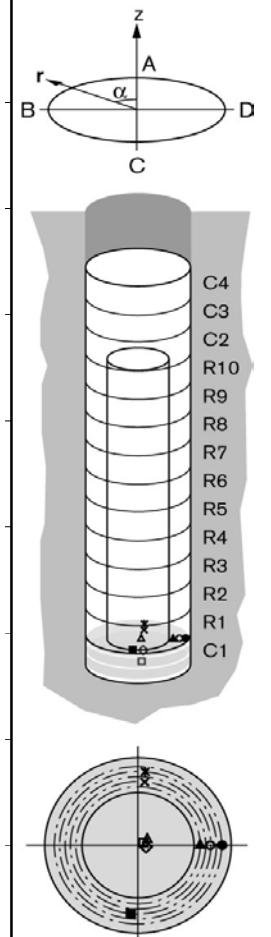
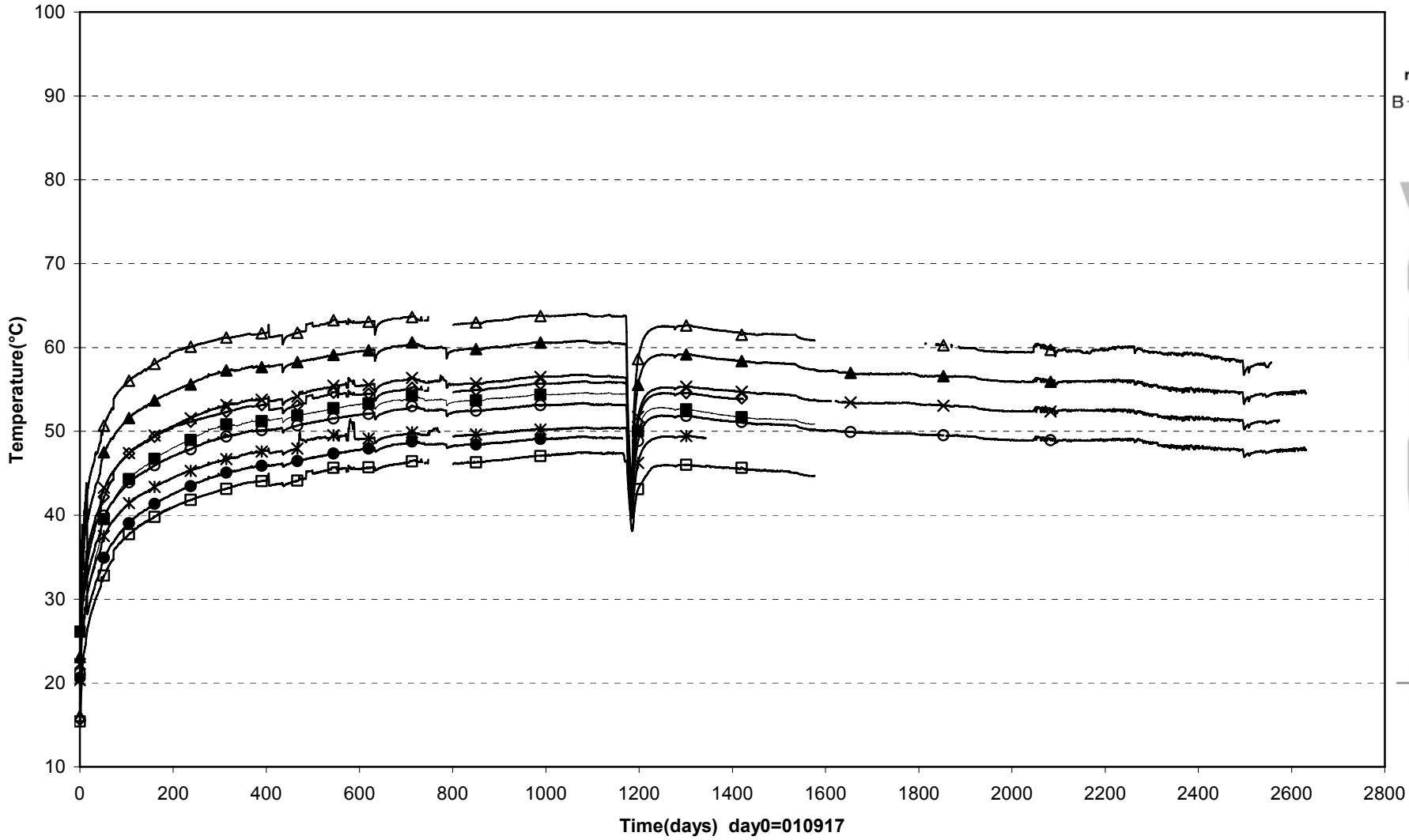

- TBU10001(0.054\270°\50) ◇ TBU10002(0.254\270°\0.050) △ TBU10003(0.454\270°\0.050) × TBU10004(0.454\355°\0.635) * TBU10005(0.454\355°\0.735)
- TBU10007(0.454\175°\0.685) ▲ TBU10008(0.454\270°\0.585) ○ TBU10009(0.454\270°\0.685) ● TBU10010(0.454\270°\0.785)

Prototype\Hole 1 \Ring5 (010917-081201)
 Temperature - Pentronic

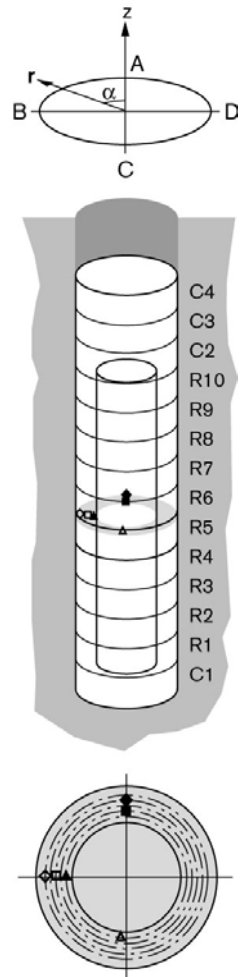
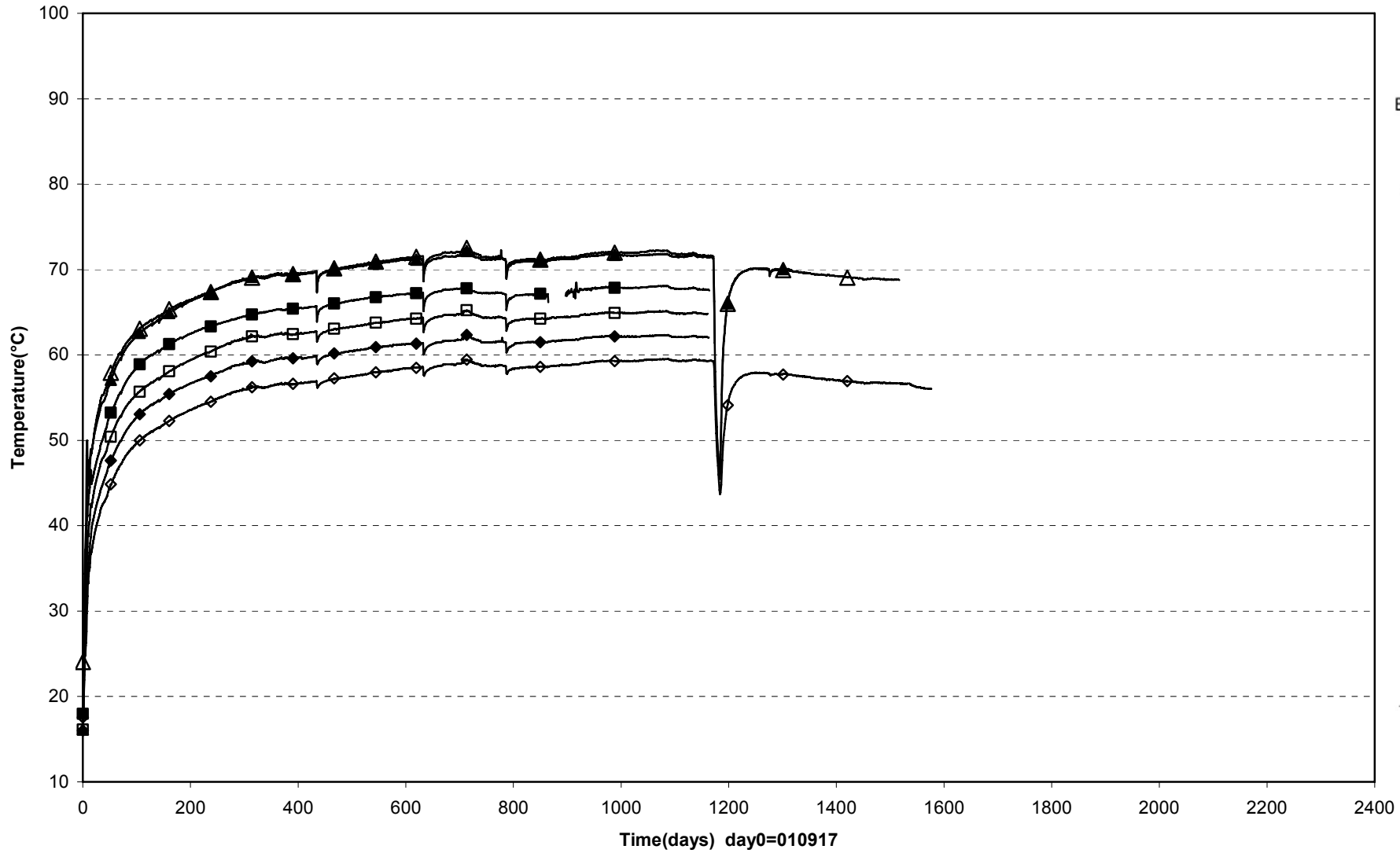

Prototype\Hole 1 \Ring5 (010917-081201)
 Temperature - Pentronic

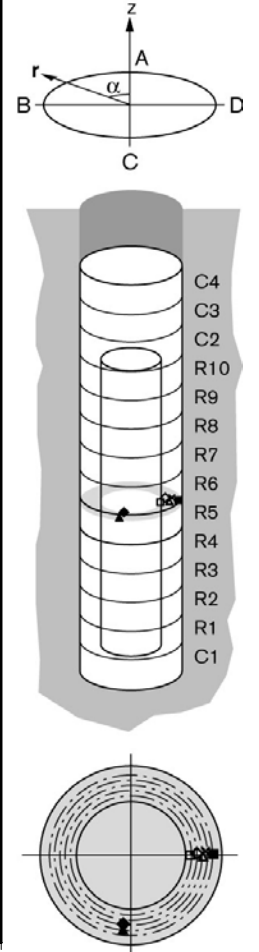
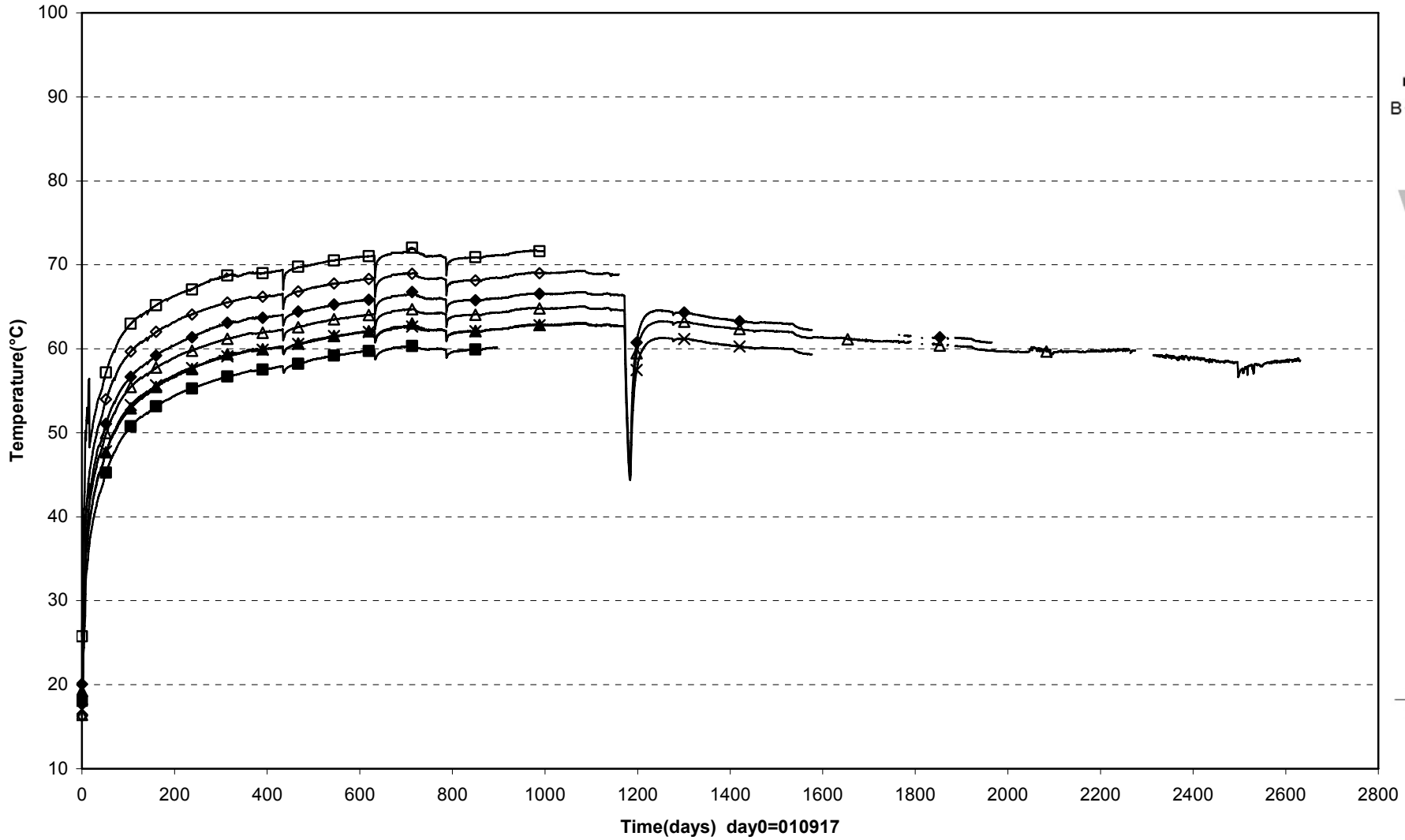

Prototype\Hole 1 \Ring10 (010917-081201)
 Temperature - Pentronic

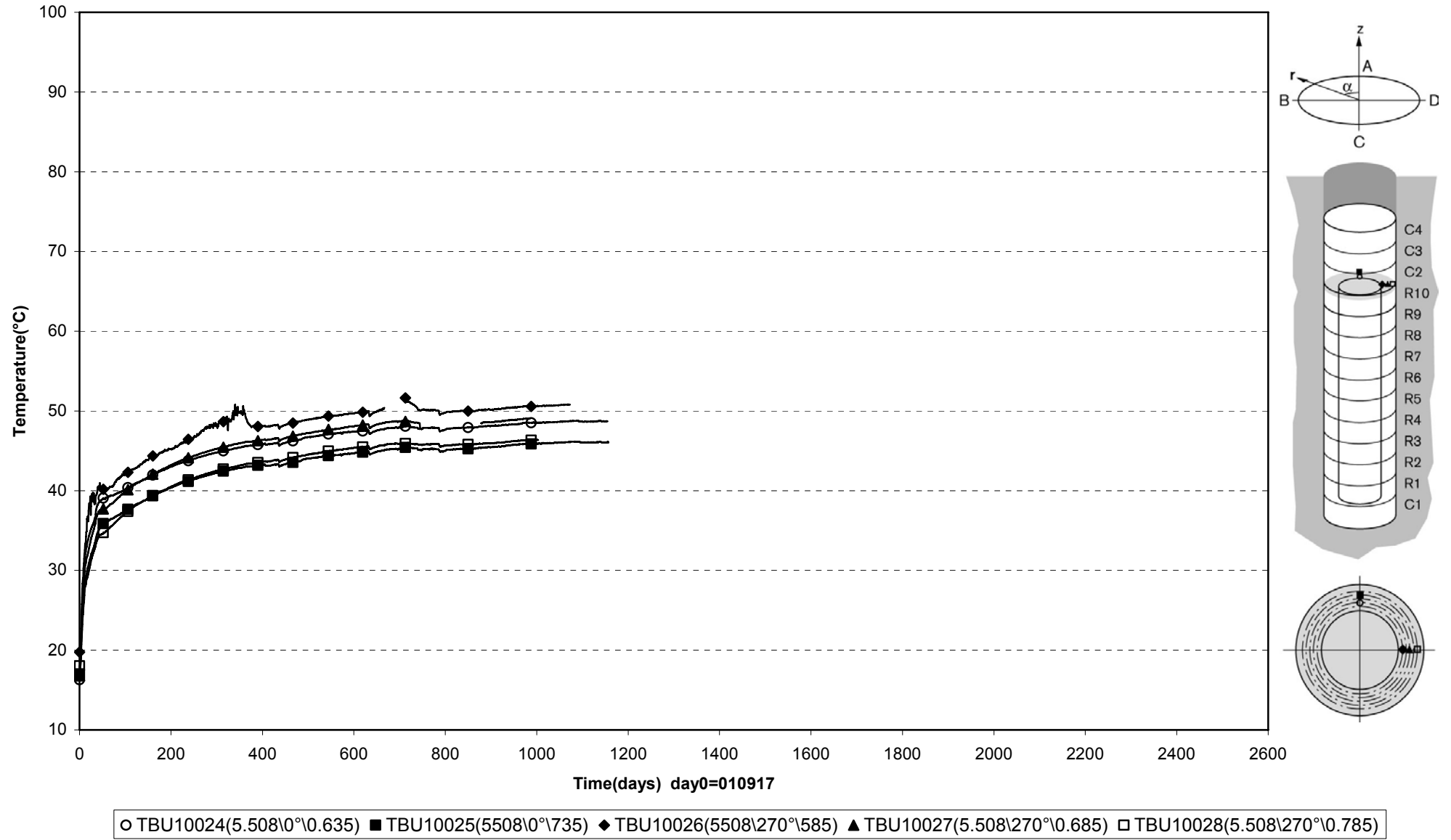

Prototype\Hole 1 \Cyl.3 and Cyl.4 (010917-081201)
 Temperature - Pentronic

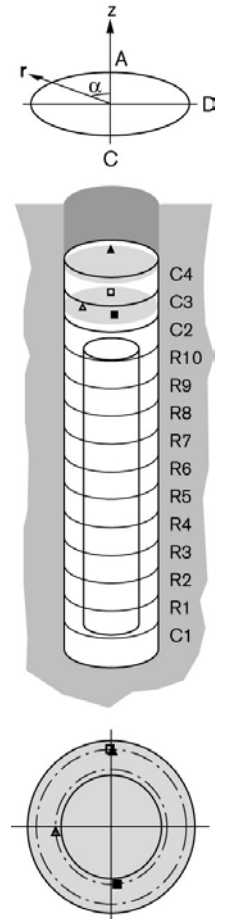
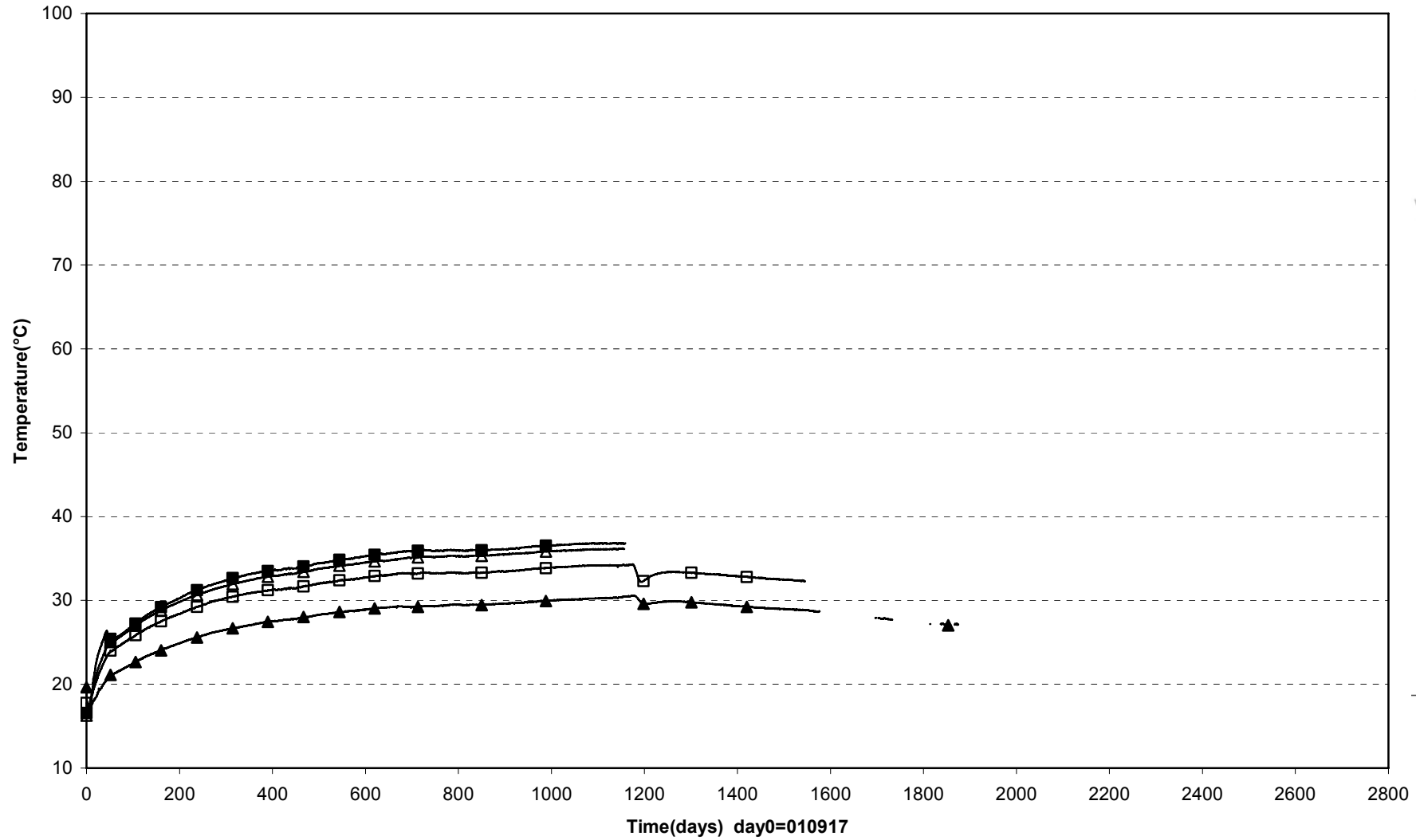

□ TBU10029(6.317\0°\0.785) △ TBU10030(6.317\95°\0.585) ■ TBU10031(6.317\185°\0.585) ▲ TBU10032(7.026\0°\0.785)

Prototype\Hole 1 (010917-081201)
 Temperature - Geokon

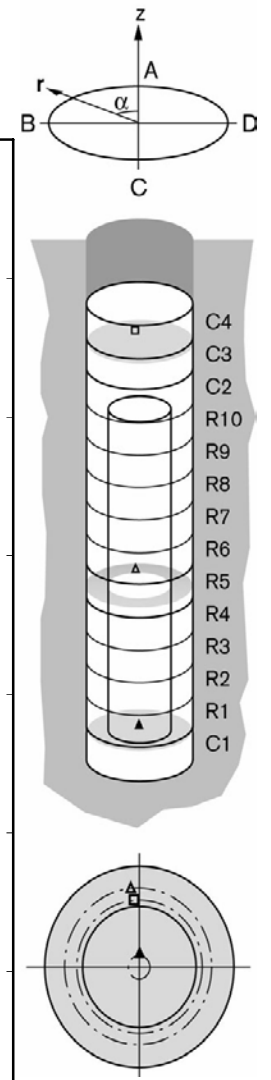
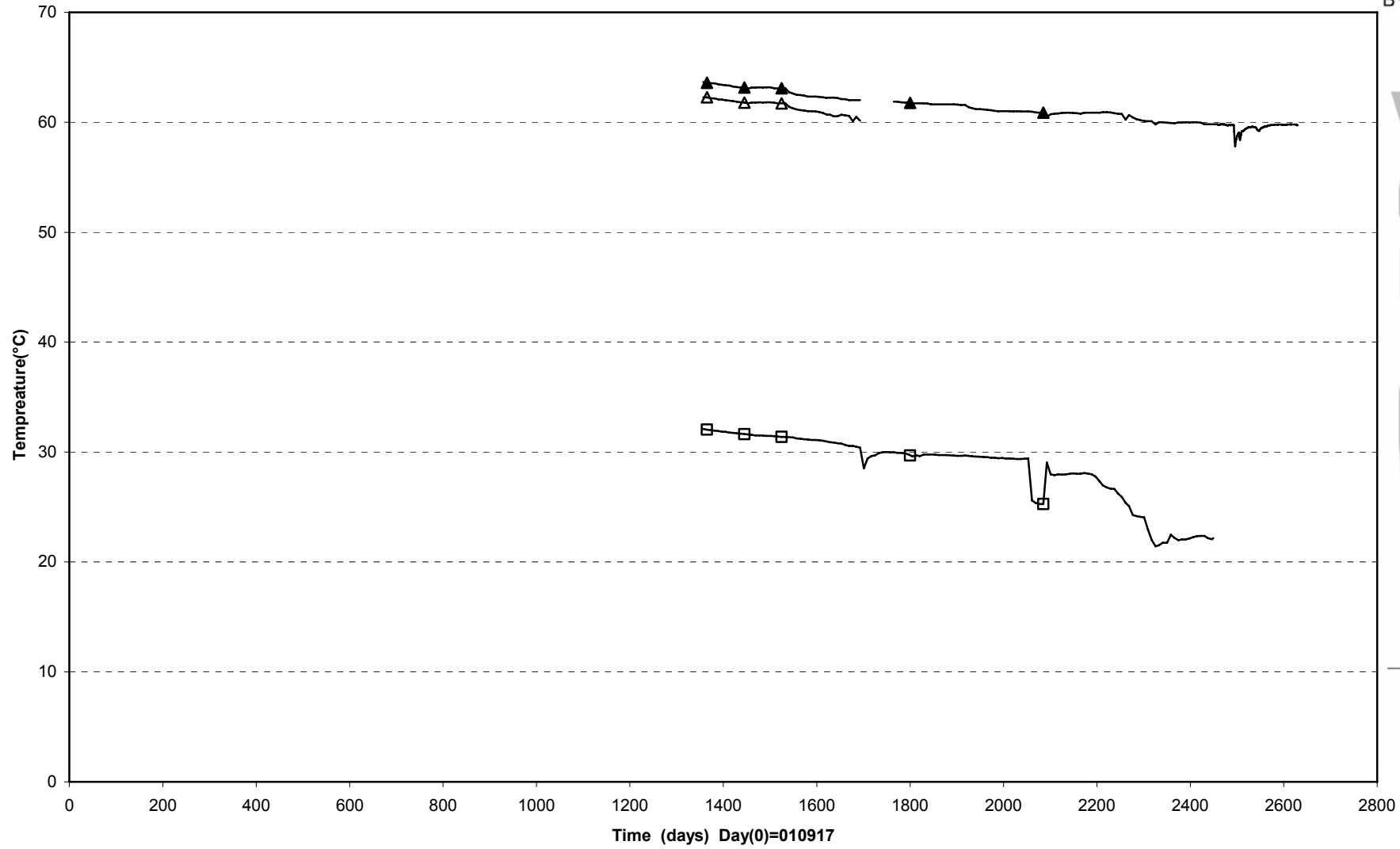

▲ PBU10002(0.504\0°\0.100) △ PBU10011(2.780\5°\0.685) □ PBU10026(6.567\5°\0.585)

Prototype\Hole 1 (010917-081201)
 Tempreture - Geokon

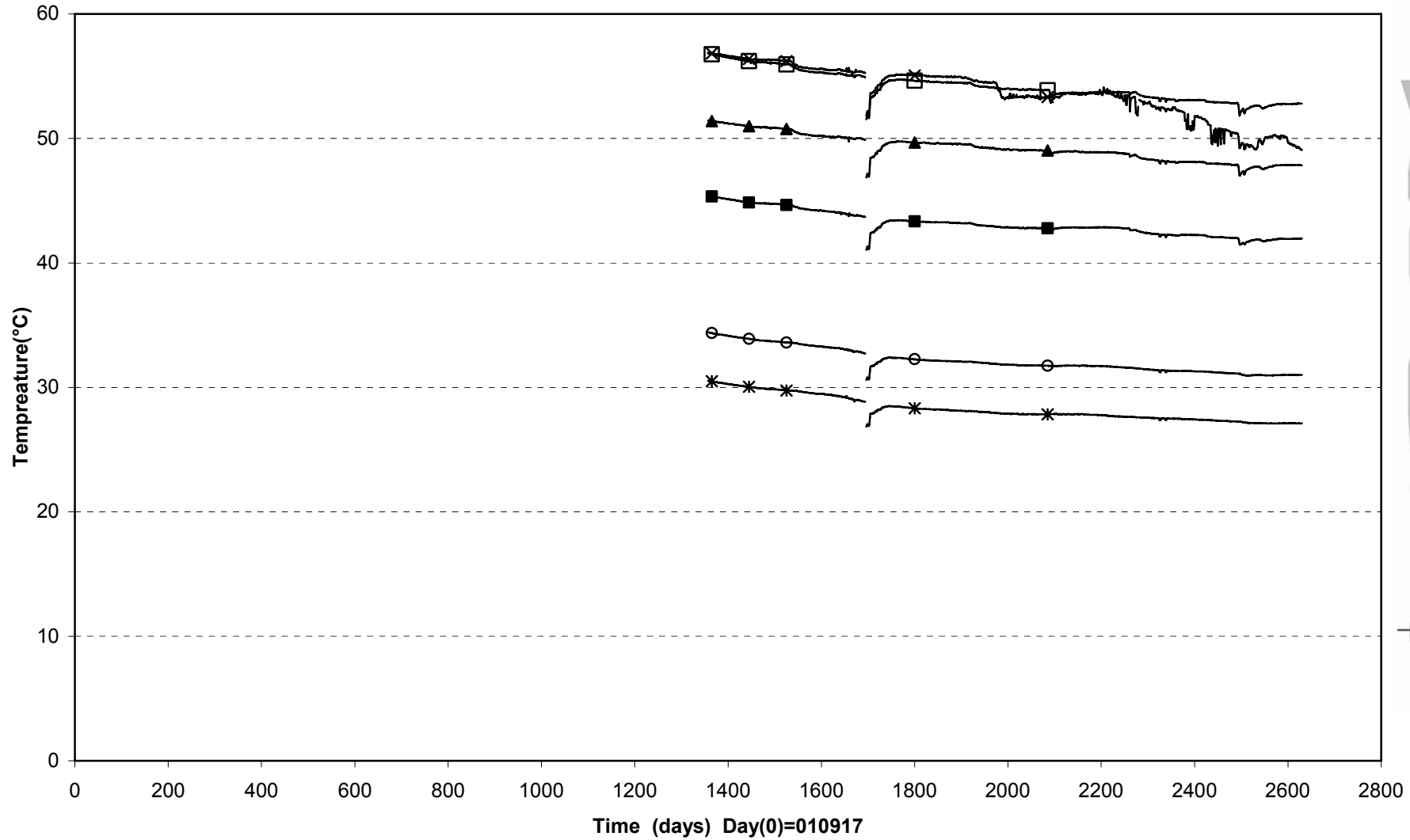

× UBU10002(0.254\90°\0.100) ▲ UBU10003(0.344\355°\0.585) □ UBU10010(2.780\175°\0.825) ■ UBU10012(5.308\355°\0.785)
 ○ UBU10013(6.317\90°\0.050) * UBU10014(6.916\90°\0.050)

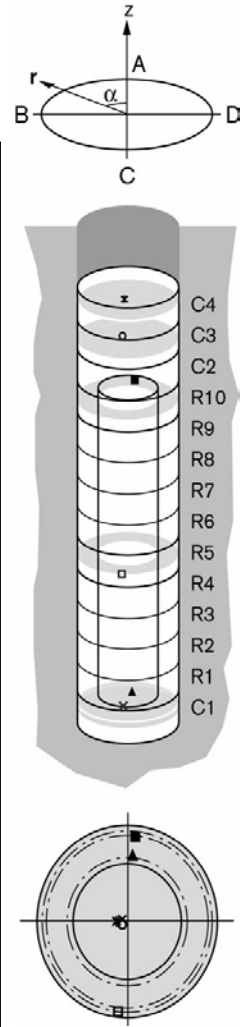

Prototype\Rock\Hole 1 (010917-081201)
 Temperature - Pentronic

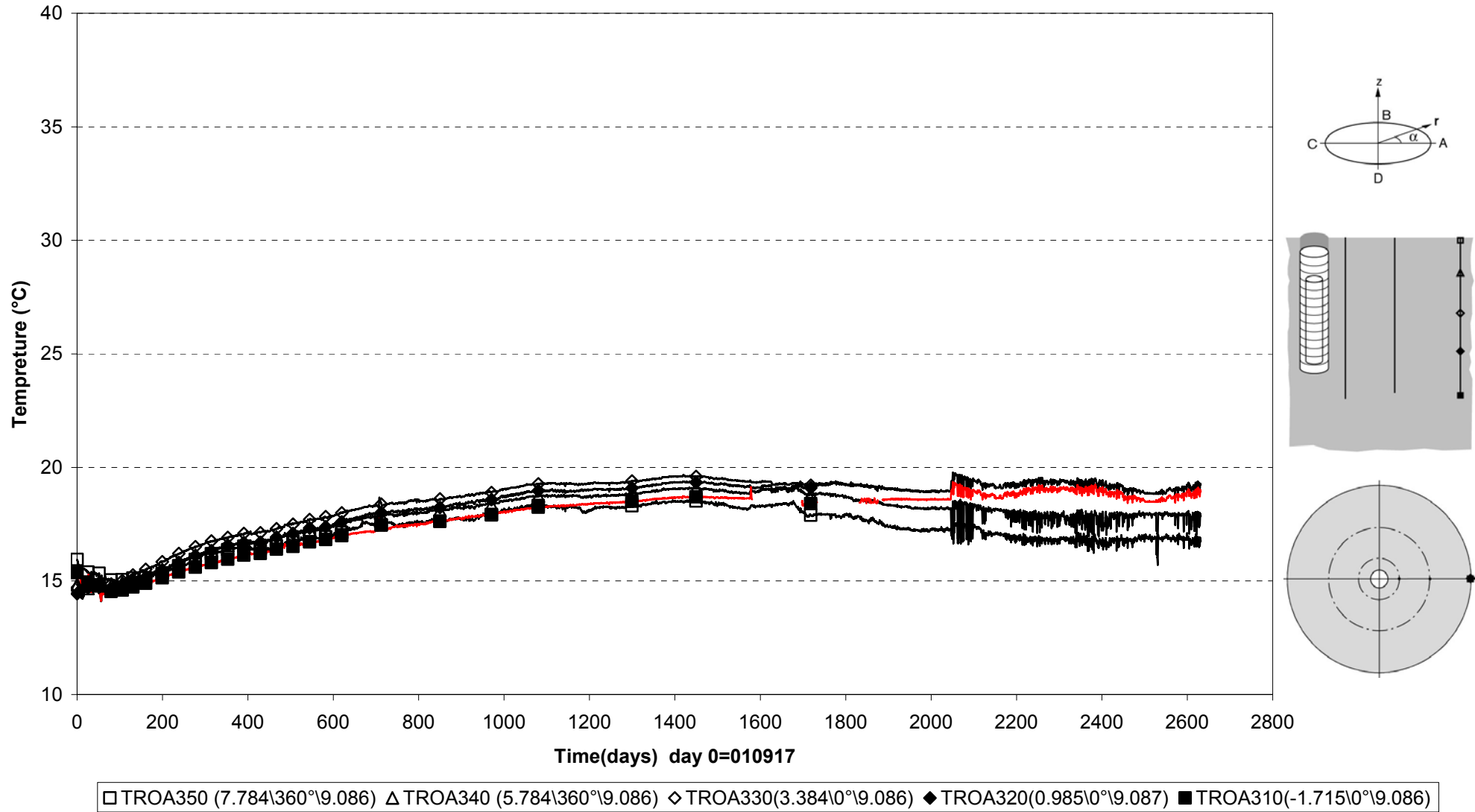

Prototype\Rock\Hole 1 (010917-081201)
 Temperature - Pentronic

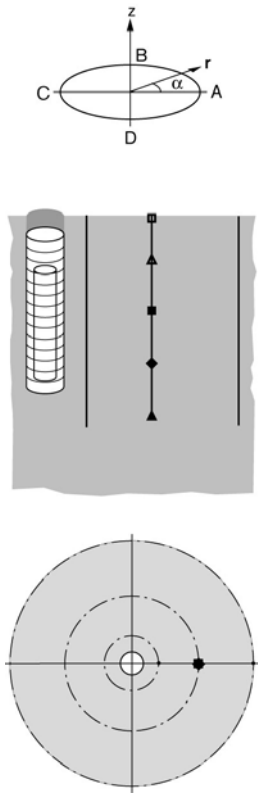
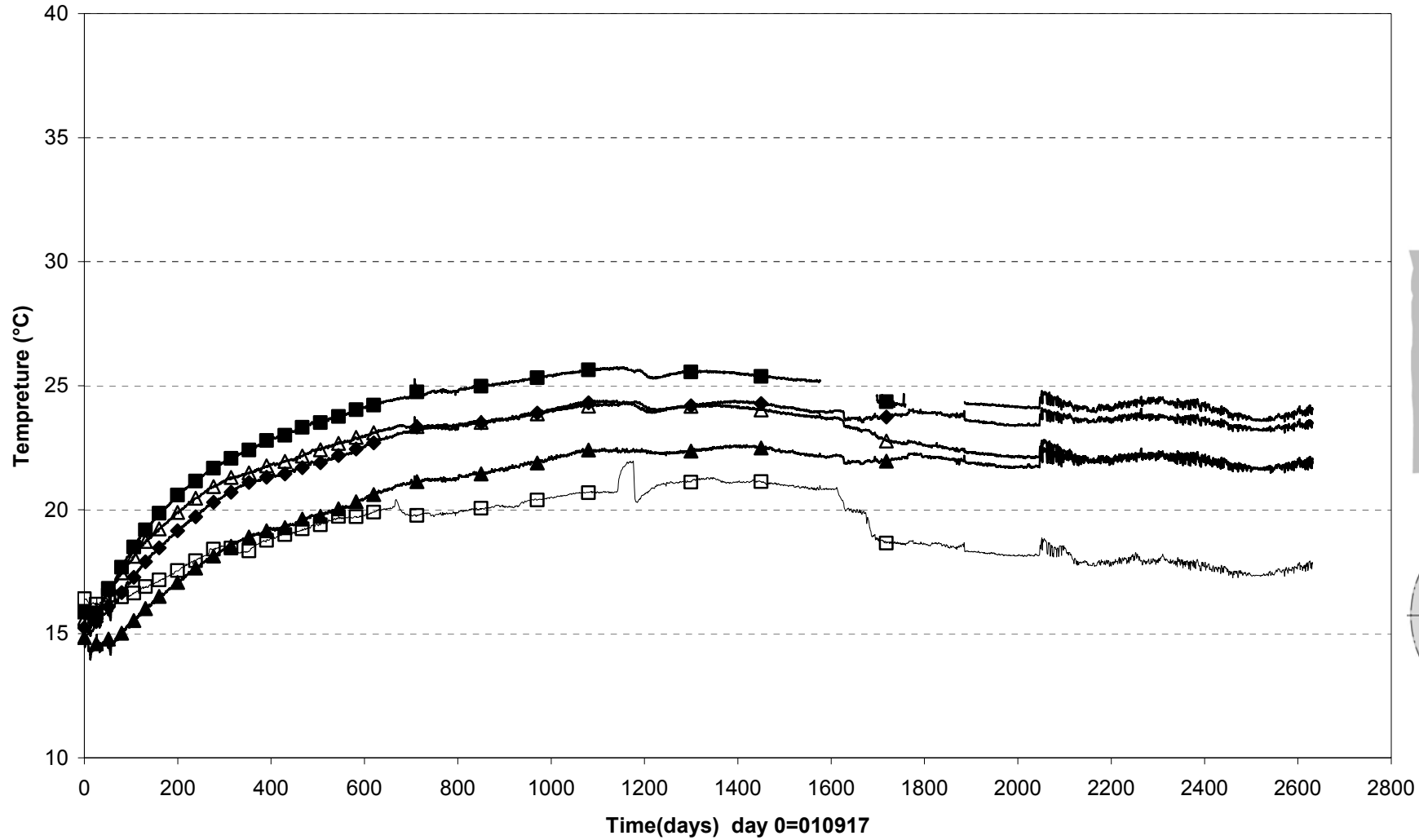

Prototype\Rock\Hole 1 (010917-081201)
 Temperature - Pentronic

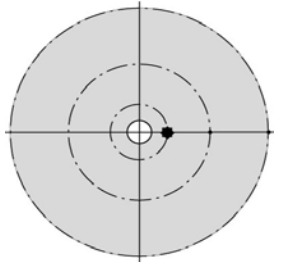
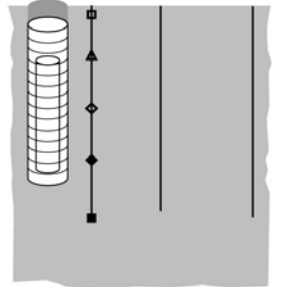
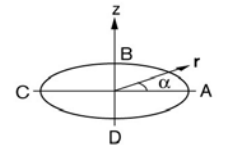
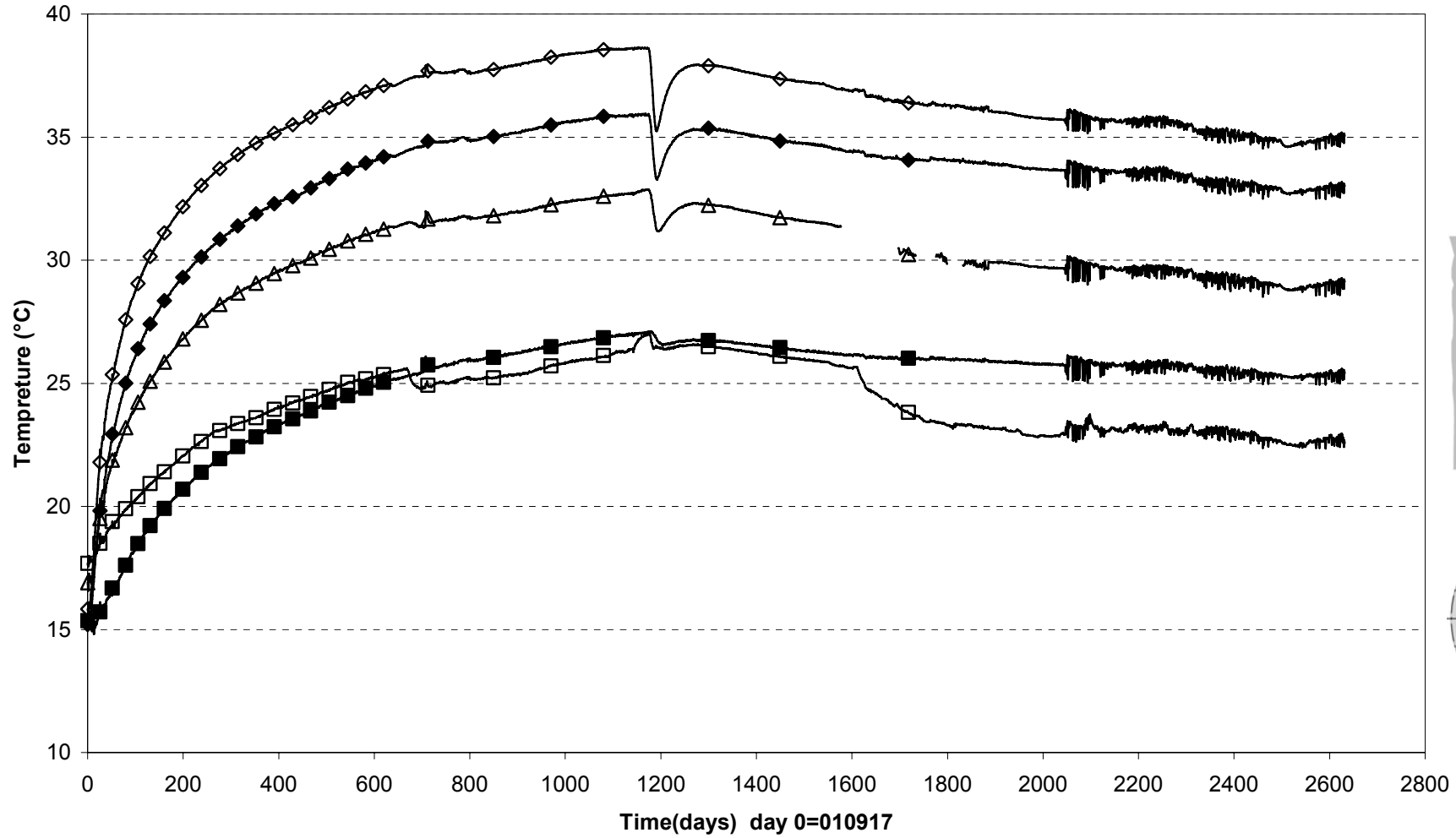

□ TROA1050(7.662\359°\2.020) △ TROA1040(5.662\359°\2.028) ◇ TROA1030(3.262\359°\2.038) ◆ TROA1020(0.862\359°\2.048) ■ TROA1010(-1.838\359°\2.059)

Prototype\ Hole 1 (010917-081201)
Canister power

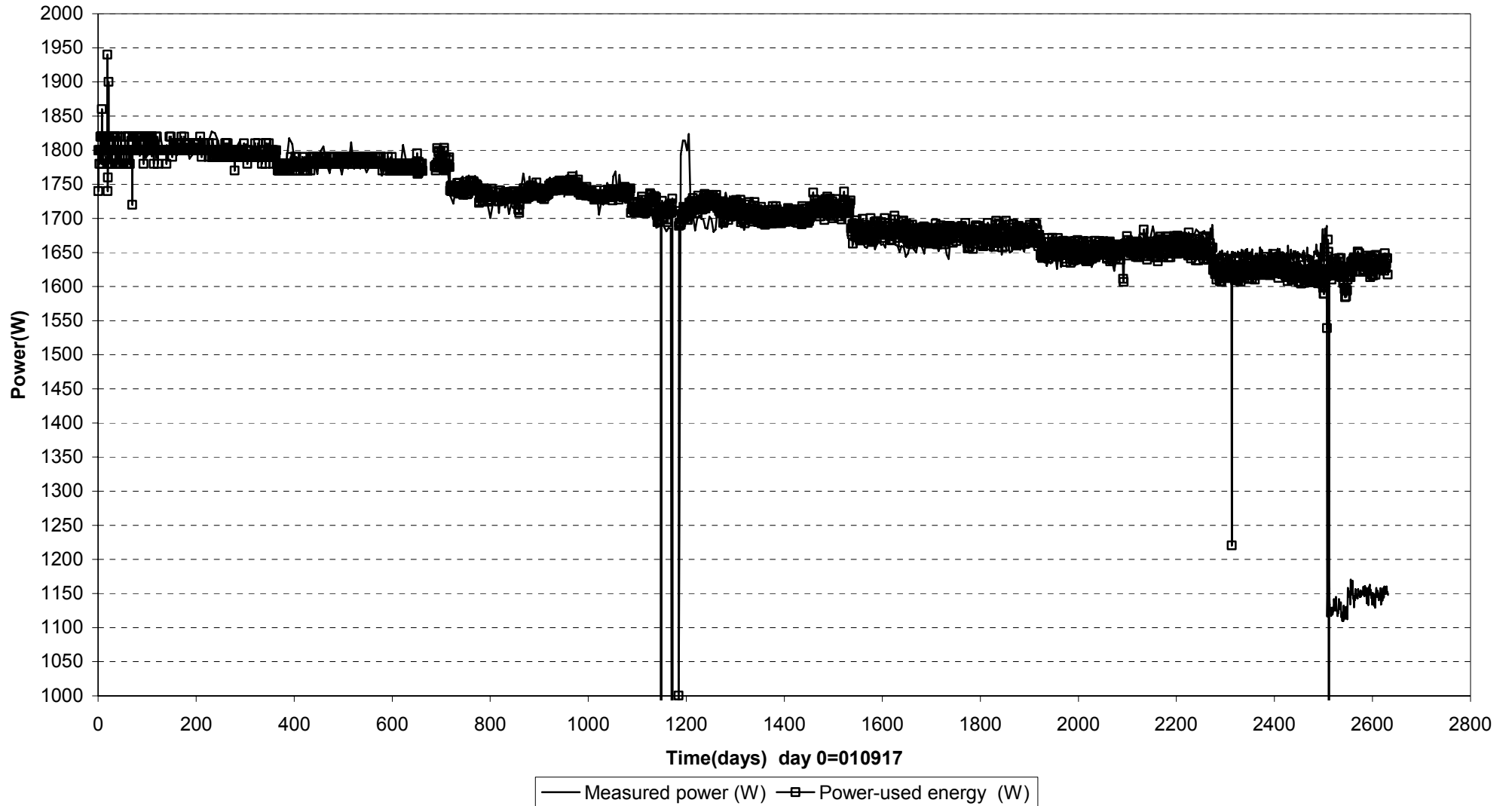

Prototype\ Hole 1 \Canister (010917-070601)
 Max. temperature on the canister surface - Optical fiber cables

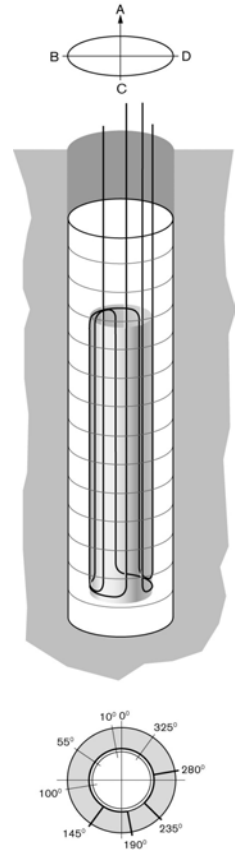

Prototype\ Hole 1 \ Canister (041201)
Temperature profile on the canister surface - Optical fiber cables

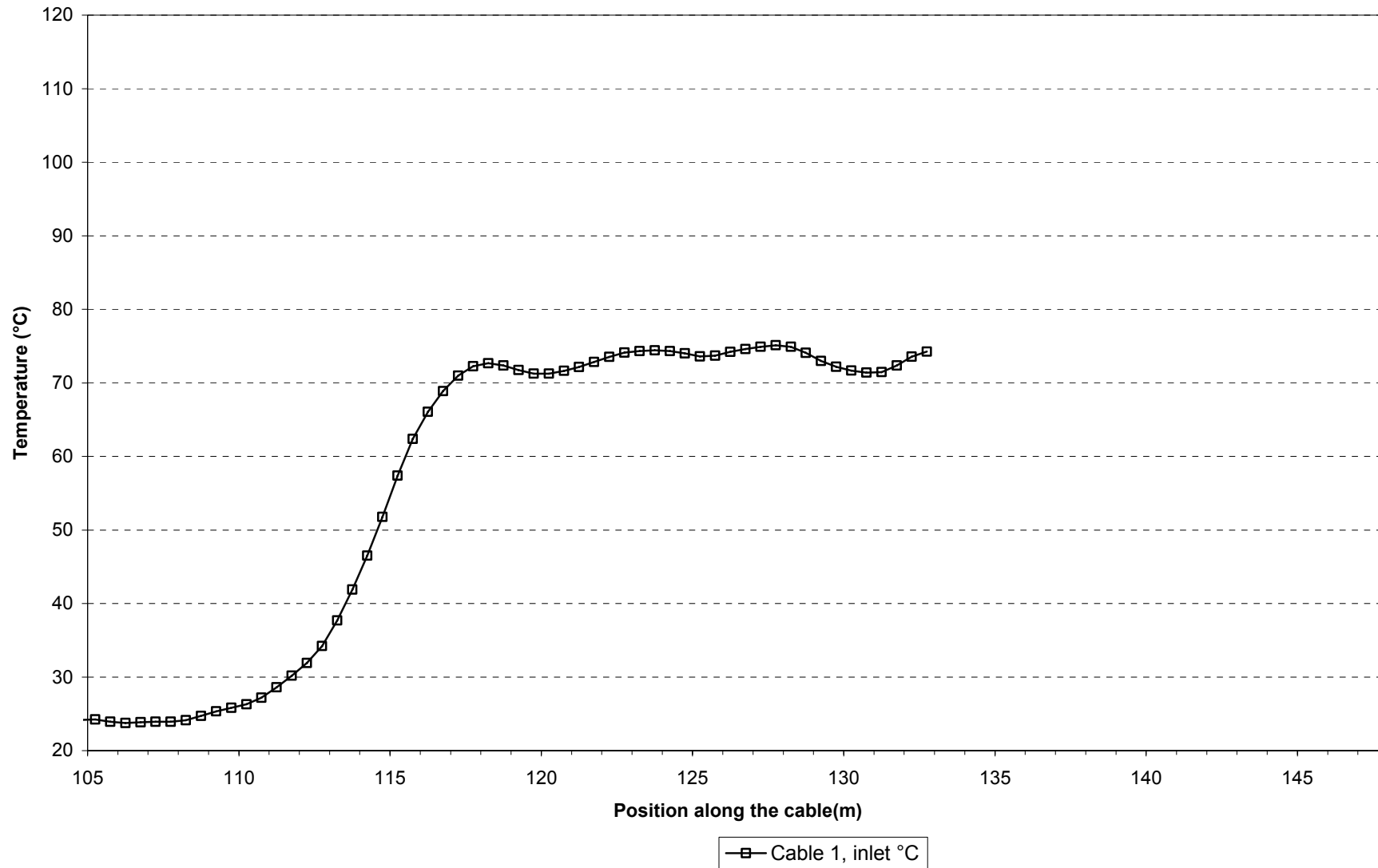

Appendix 2

Dep. hole 3

Prototype\Hole 3\Cyl.1 (010917-081201)
Total pressure - Geokon

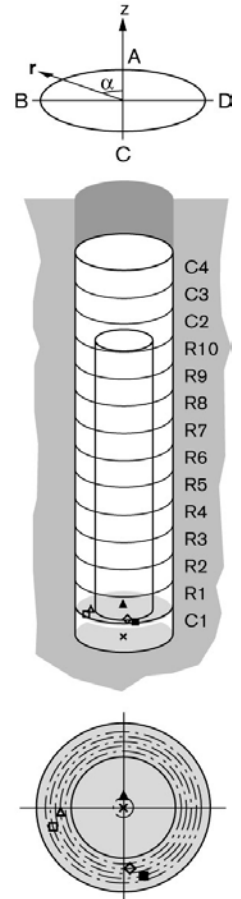
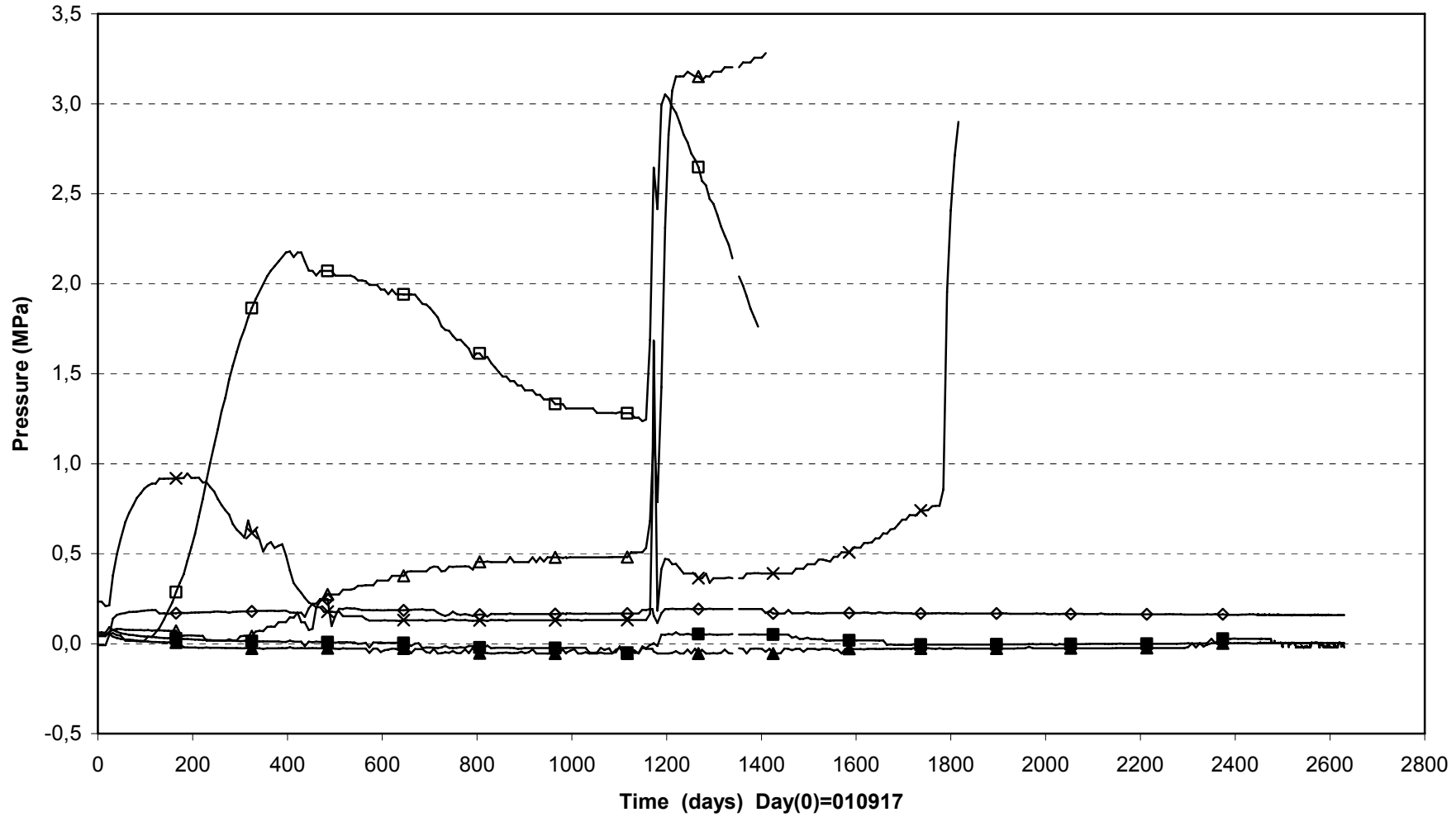

PrototypeHole 3 \Ring5 (010917-081201)
 Total pressure - Geokon

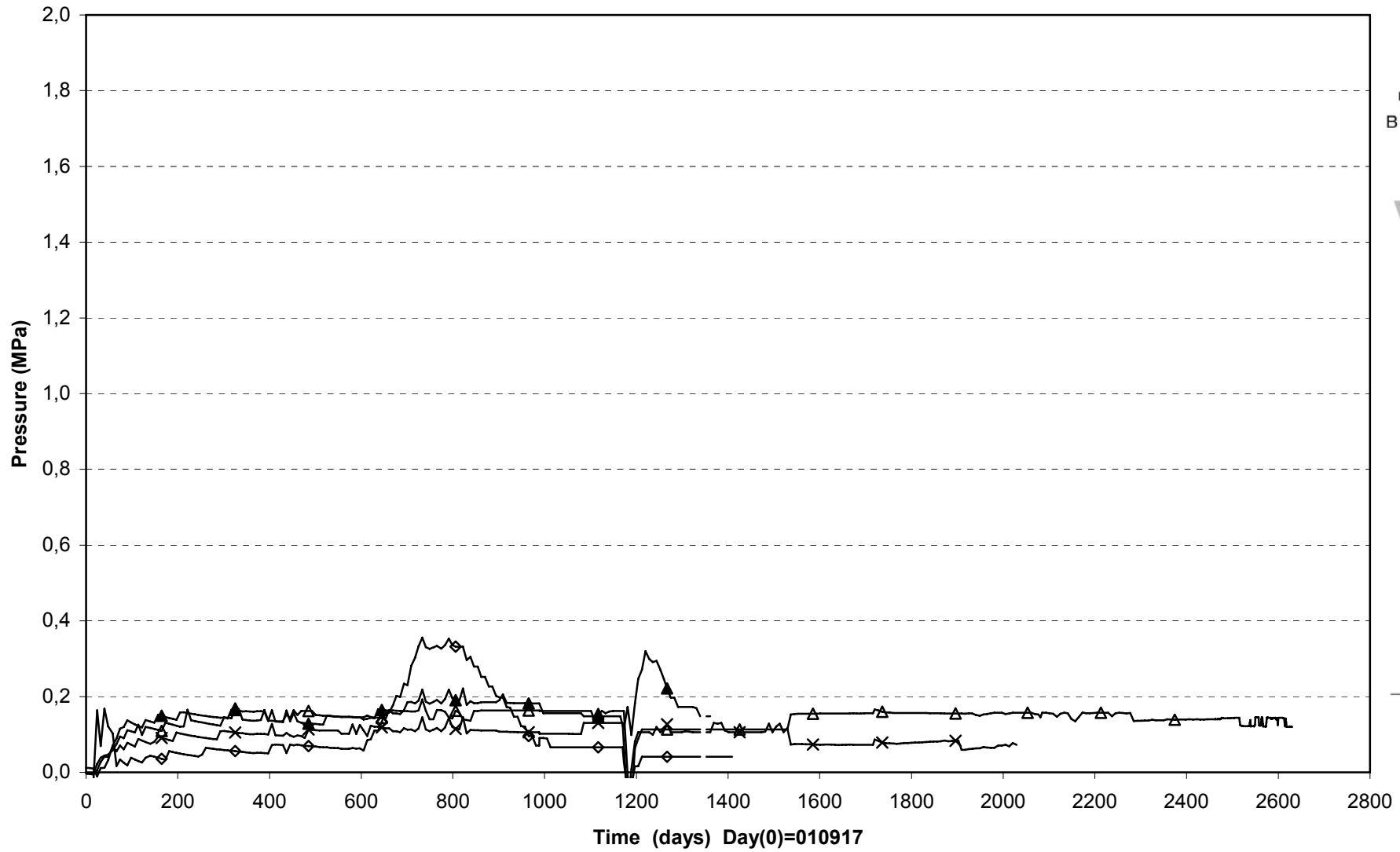

× PBU30013(2.771\95°\0.585) ▲ PBU30011(2.771\5°\0.685) ◇ PBU30014(2.771\95°\0.785) △ PBU30015(3.021\185°\0.535)

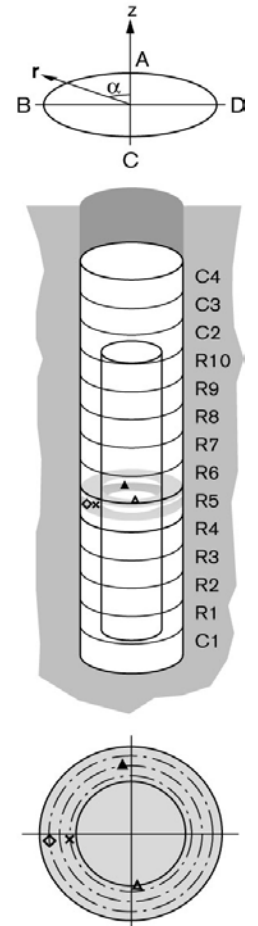

Prototype\Hole 3\Ring10 and Cyl.3 (010917-081201)
Total pressure - Geokon

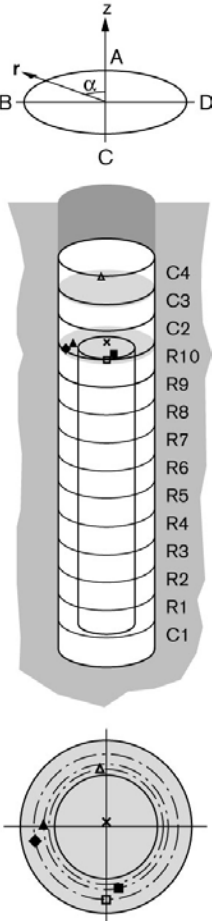
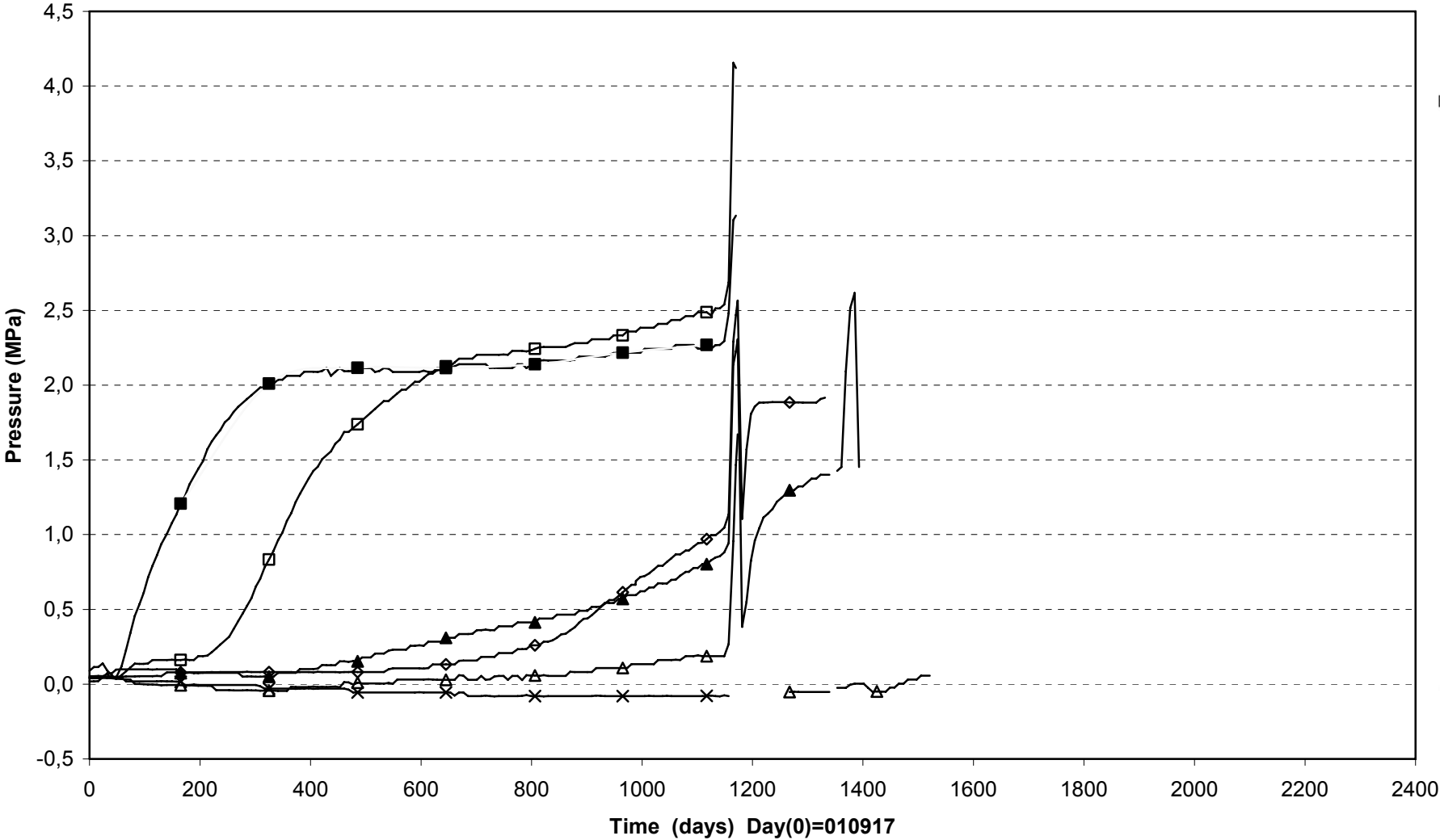

Prototype\Hole 3 \Cyl.1 and Ring5 (010917-081201)
 Total pressure - Kulite

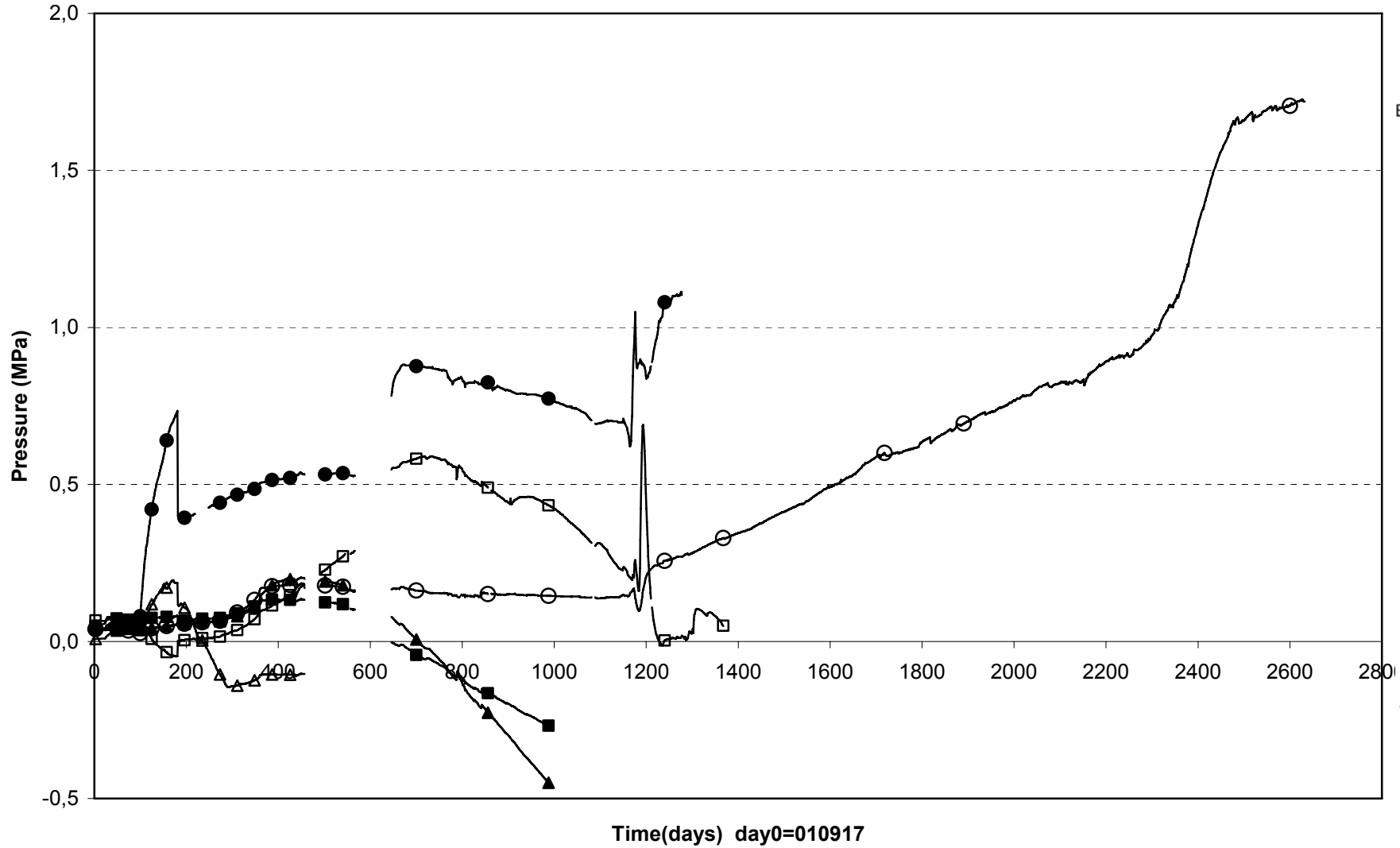

- | | | | |
|----------------------------|------------------------------|----------------------------|----------------------------|
| □ PBU30003(Cyl.1\5°\0.585) | ▲ PBU30004(Cyl.1\5°\0.685) | ○ PBU30005(Cyl.1\5°\0.785) | △ PBU30010(Ring5\5°\0.585) |
| ● PBU30012(Ring5\5°\0.825) | ■ PBU30016(Ring5\185°\0.825) | | |

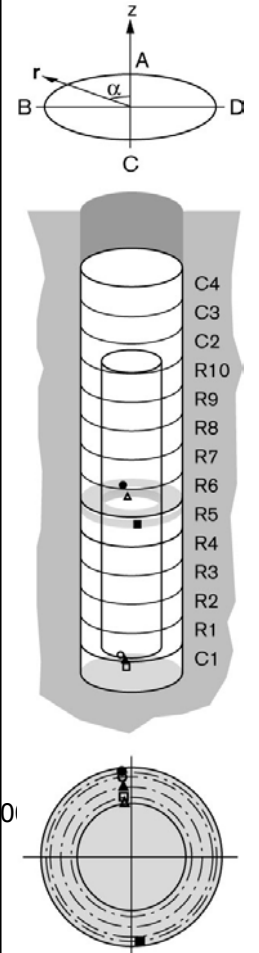

Prototype\Hole 3\Ring10 and Cyl.3-4 (010917-081201)
 Total pressure - Kulite

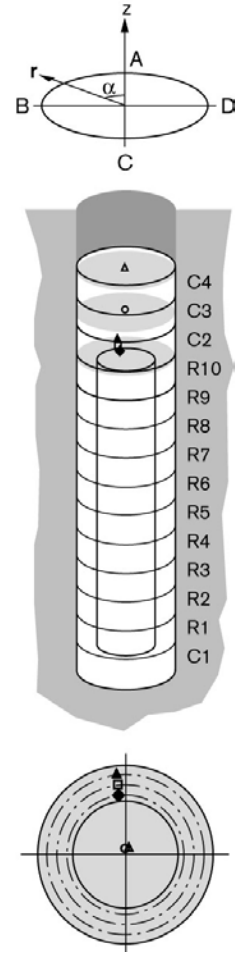
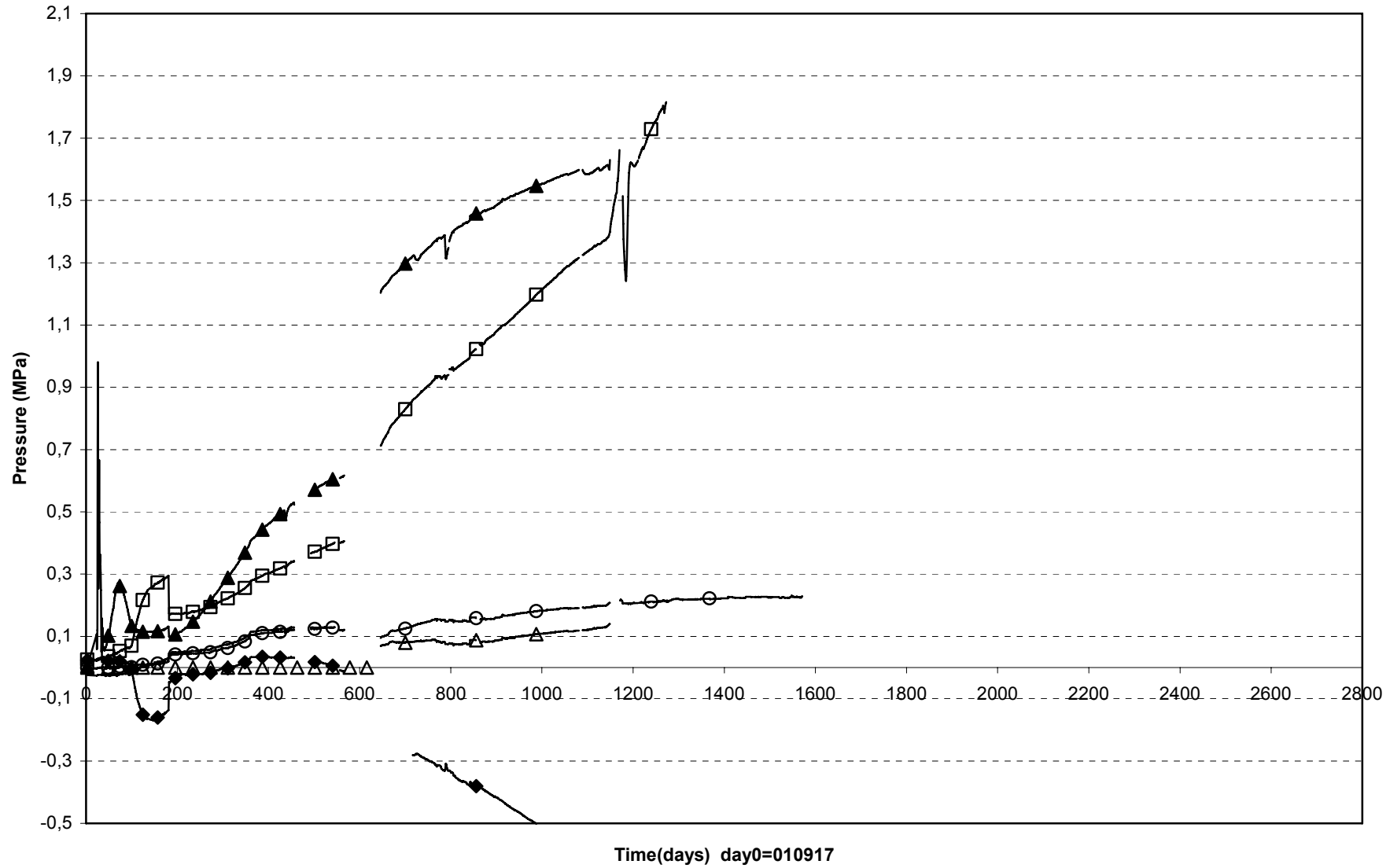

◆ PBU30018(Ring10\5°\0.585) □ PBU30019(Ring10\5°\0.685) ▲ PBU30020(Ring10\5°\0.785) ○ PBU30025(Cyl.3\0°\0.050) △ PBU30027(Cyl.4\0°\0.050)

Prototype\Hole 3\Cyl.1 (010917-081201)
Relative humidity - Vaisala

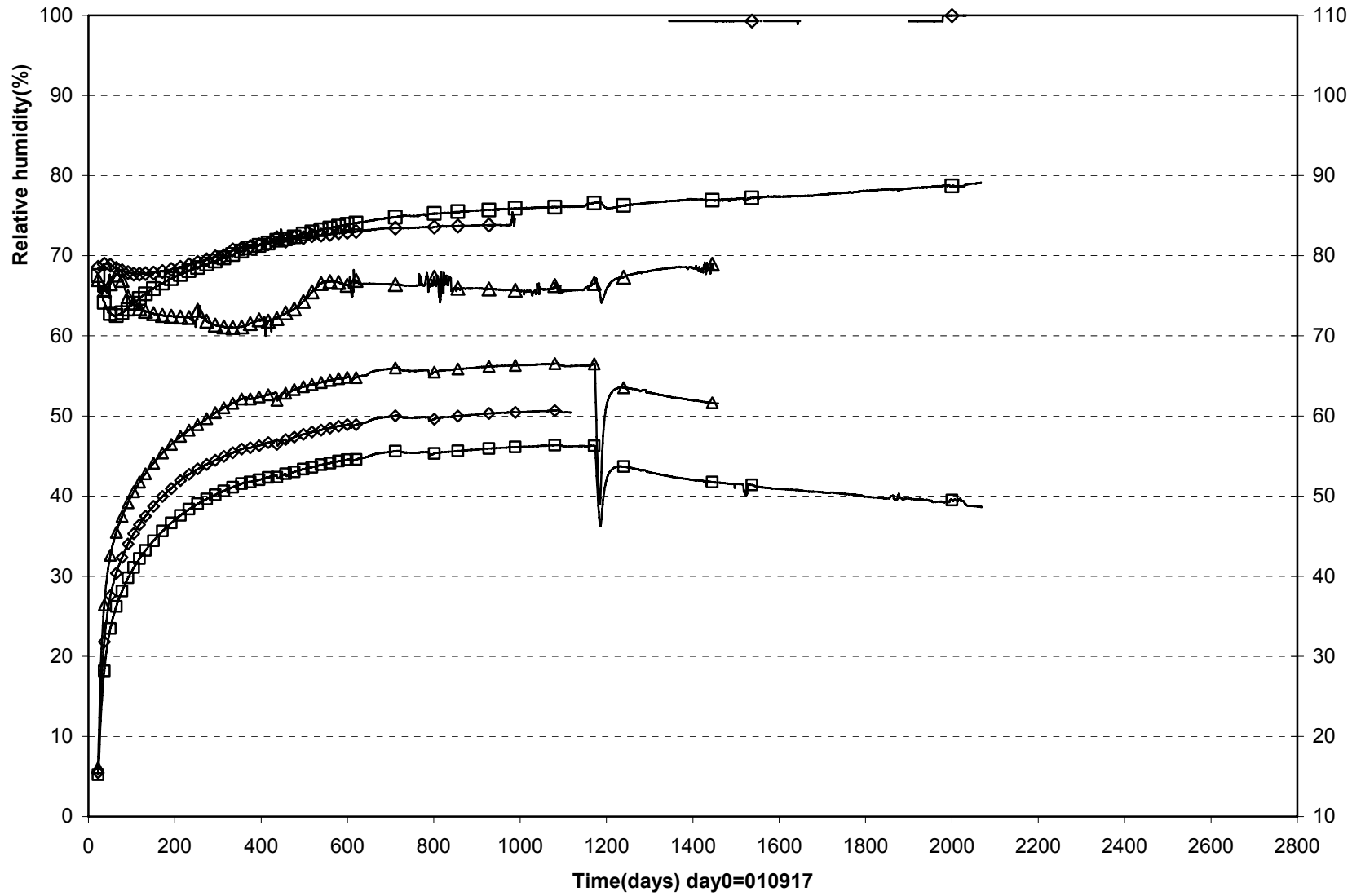

□ WBU30004(0.335\350°\0.785) ◇ WBU30005(0.335\350°\0.685) △ WBU30006(0.335\350°\0.585)

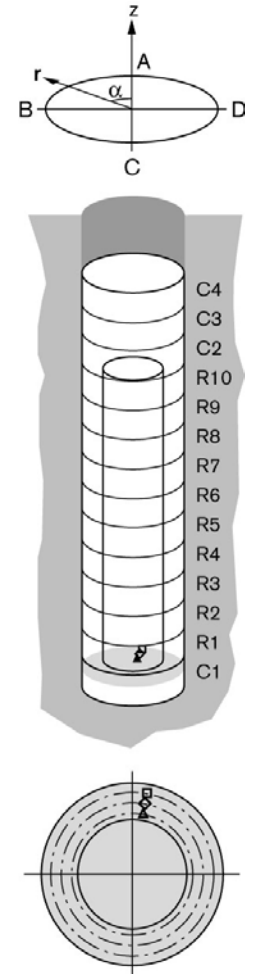

Prototype\Hole 3\Ring 5 (010917-081201)
Relative humidity - Vaisala

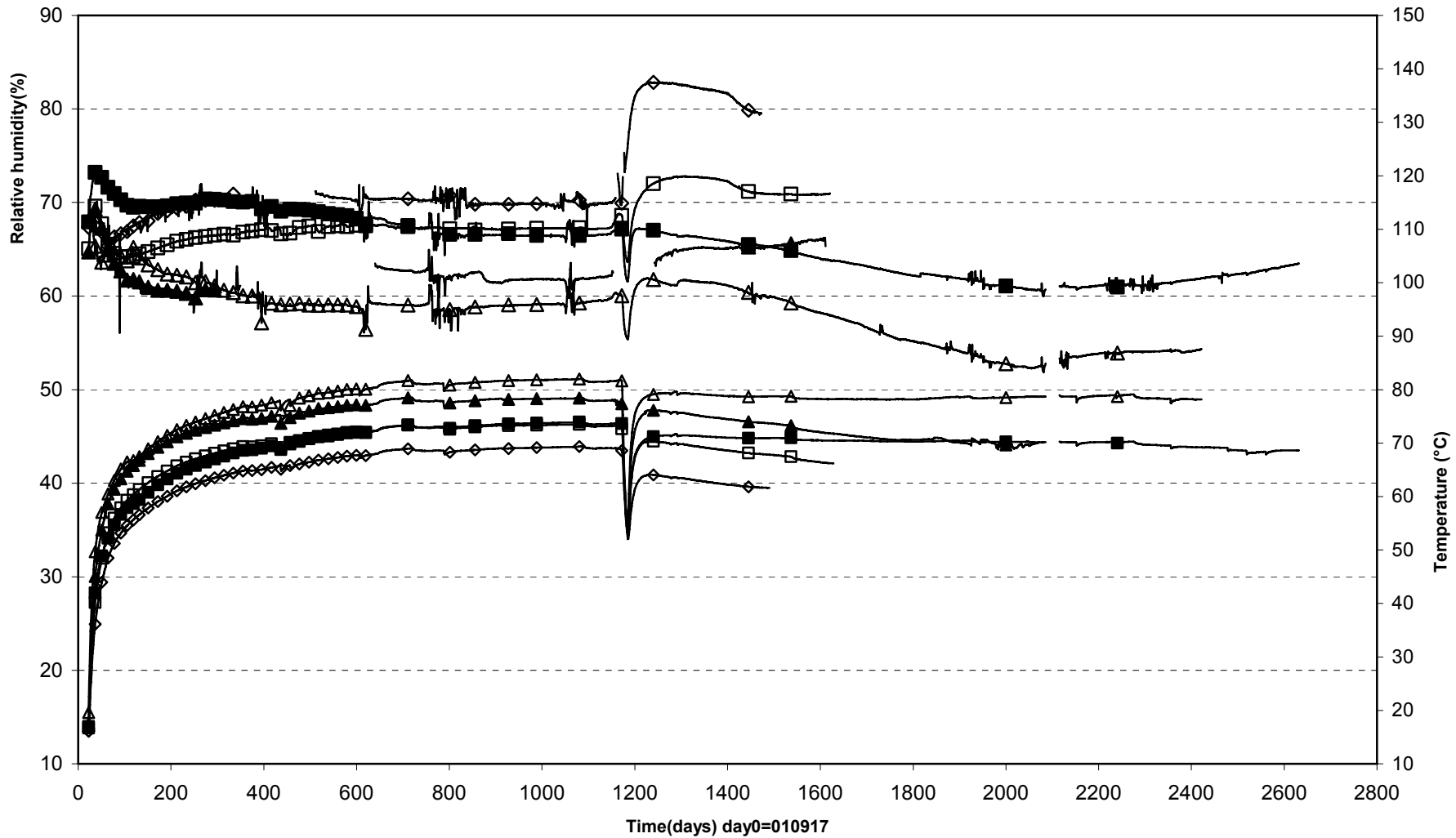

▲ WBU30013(2.840\350°\0.585)	□ WBU30014(2.840\350°\0.685)	◇ WBU30015(2.840\350°\0.785)
△ WBU30019(2.840\180°\0.535\In the slot)	■ WBU30020(2.840\180°\0.685)	

Prototype\Hole 3\Ring 10 (010917-081201)
Relative humidity - Vaisala

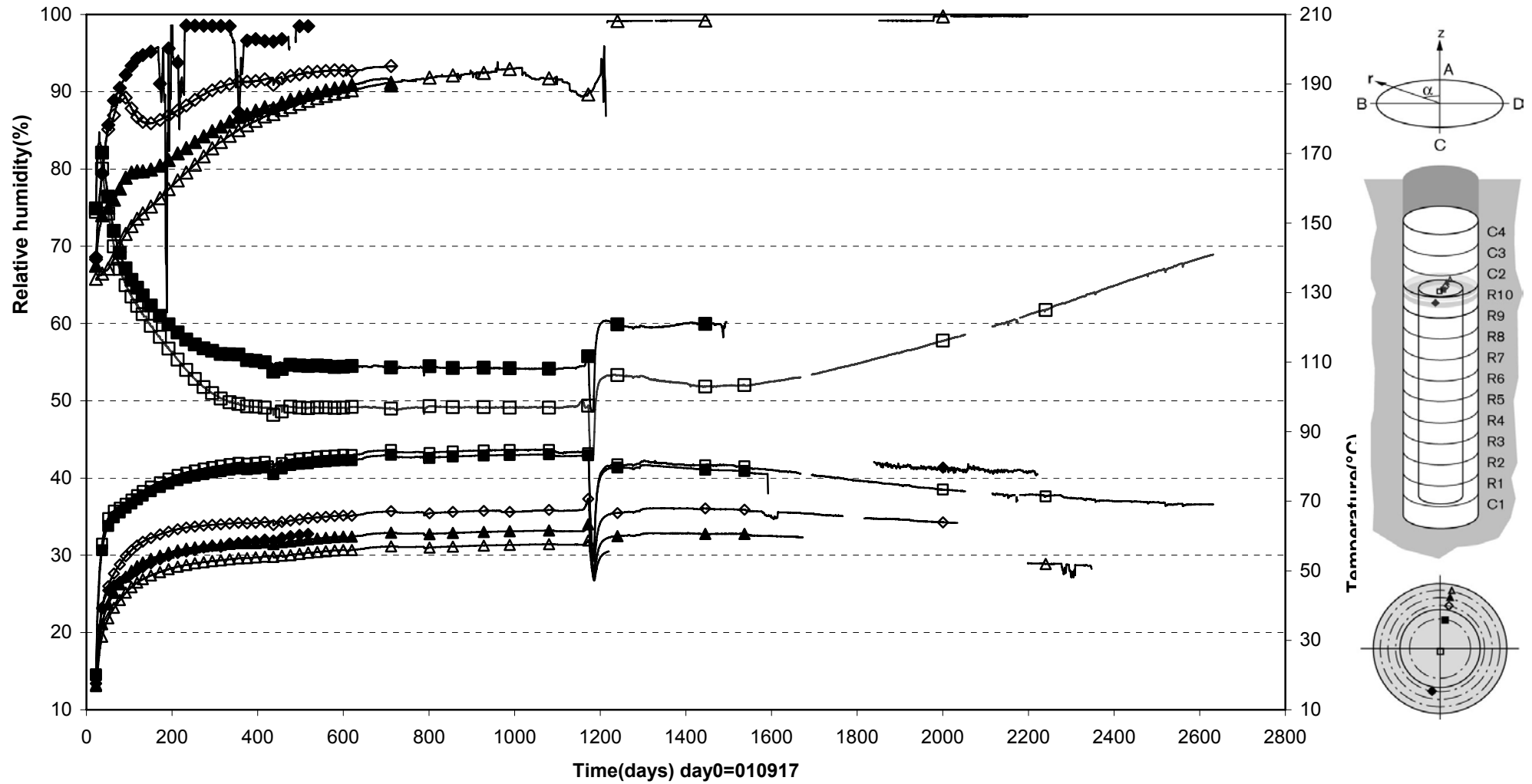

□ WBU30022(5.416\180°\0.050) ■ WBU30023(5.396\352°\0.262) ◇ WBU30024(5.396\350°\0.585) △ WBU30025(5.396\350°\0.785))
 ▲ WBU30026(5.396\350°\0.685) ◆ WBU30030(5.396\170°\0.585)

Prototype\Hole 3\Cyl.3 and Cyl.4 (010917-081201)
Relative humidity - Vaisala

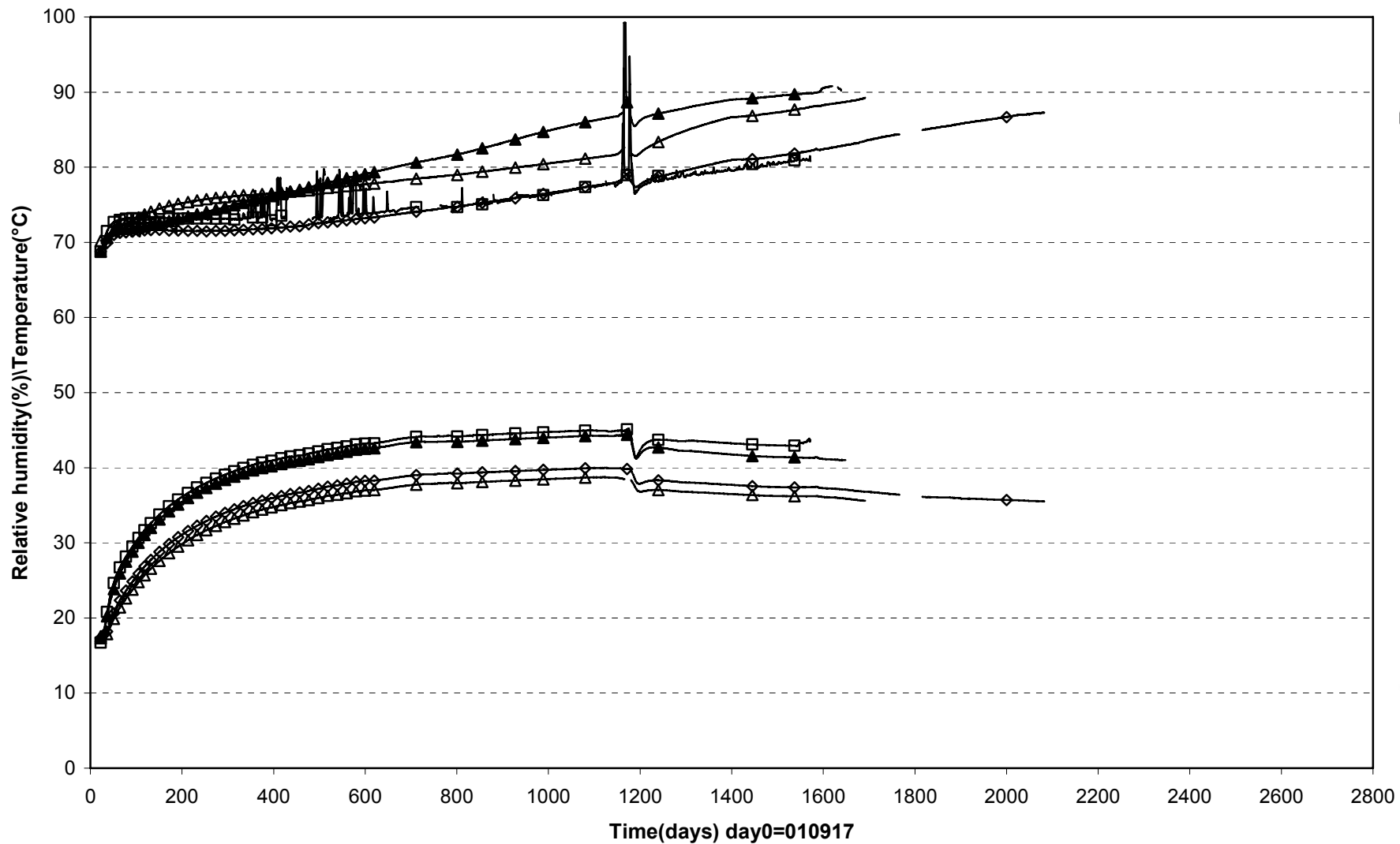

□ WBU30032(6.314\180°\0.050) ▲ WBU30033(6.314\350°\0.585) △ WBU30036(6.680\180°\0.050) ◇ WBU30037(6.840\270°\0.050)

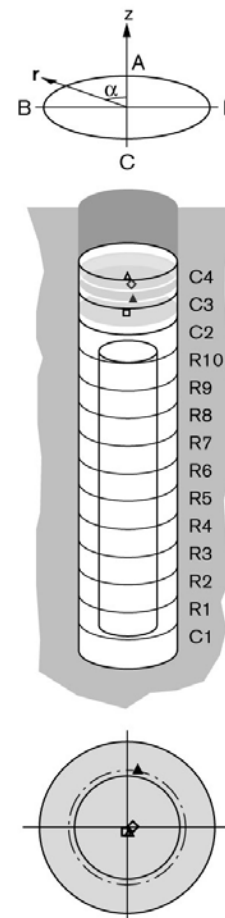

Prototype\Hole 3\Cyl.1 (010917-081201)
 Relative humidity - Rotronic

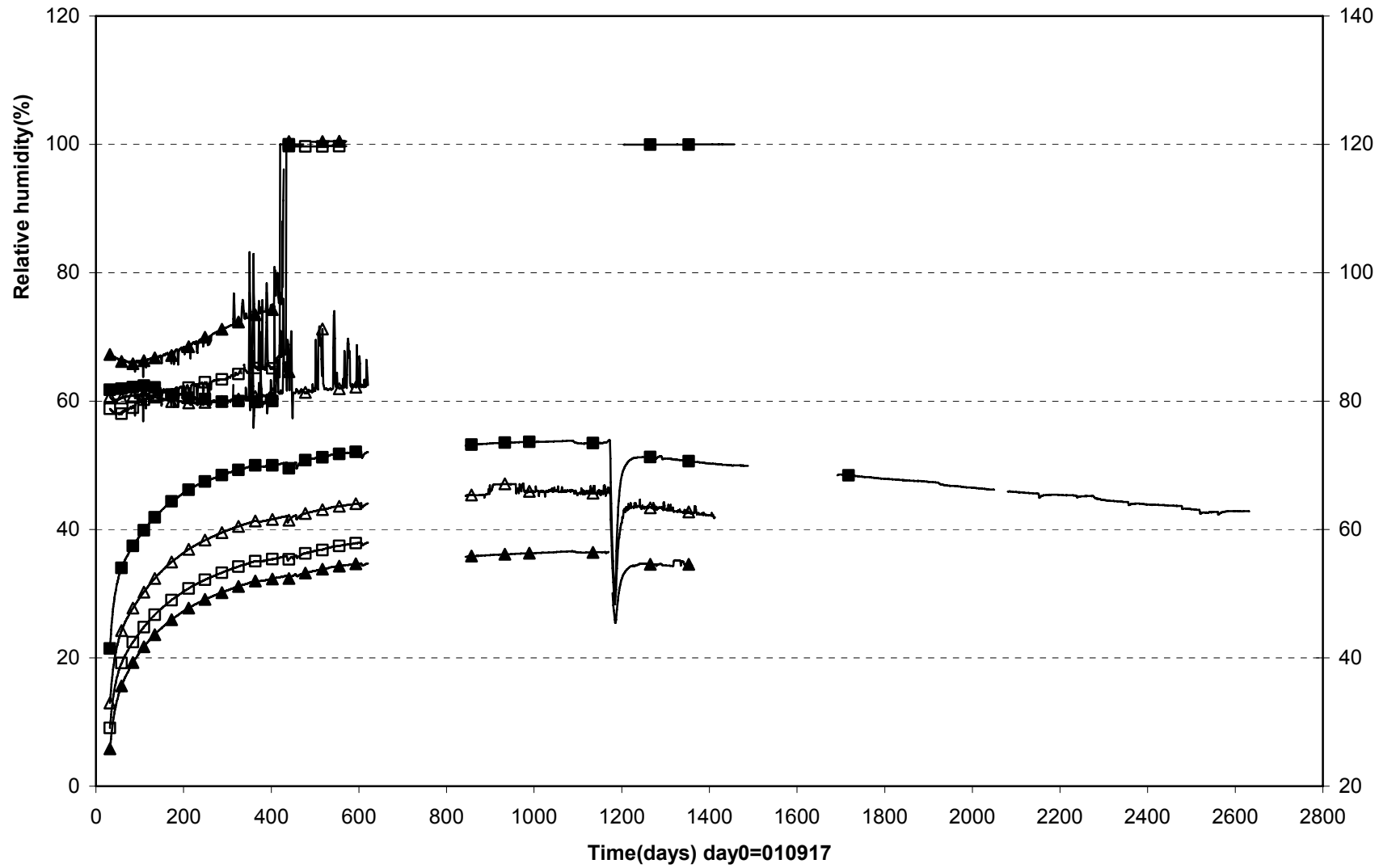

□ WBU30001(0.045\180°\0.050) △ WBU30002(0.215\0°\0.400) ■ WBU30003(0.245\180°\0.100) ▲ WBU30008(0.245\80°\0.685)

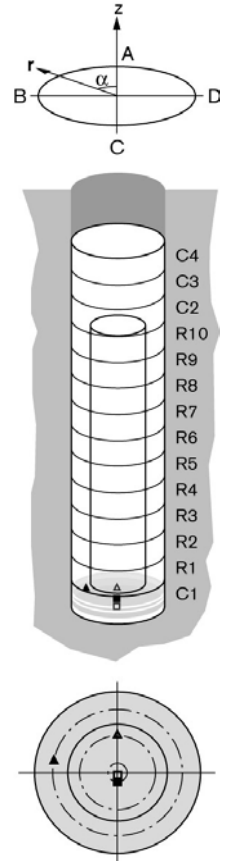

Prototype\Hole 3\Cyl.1 (010917-081201)
 Relative humidity - Rotronic

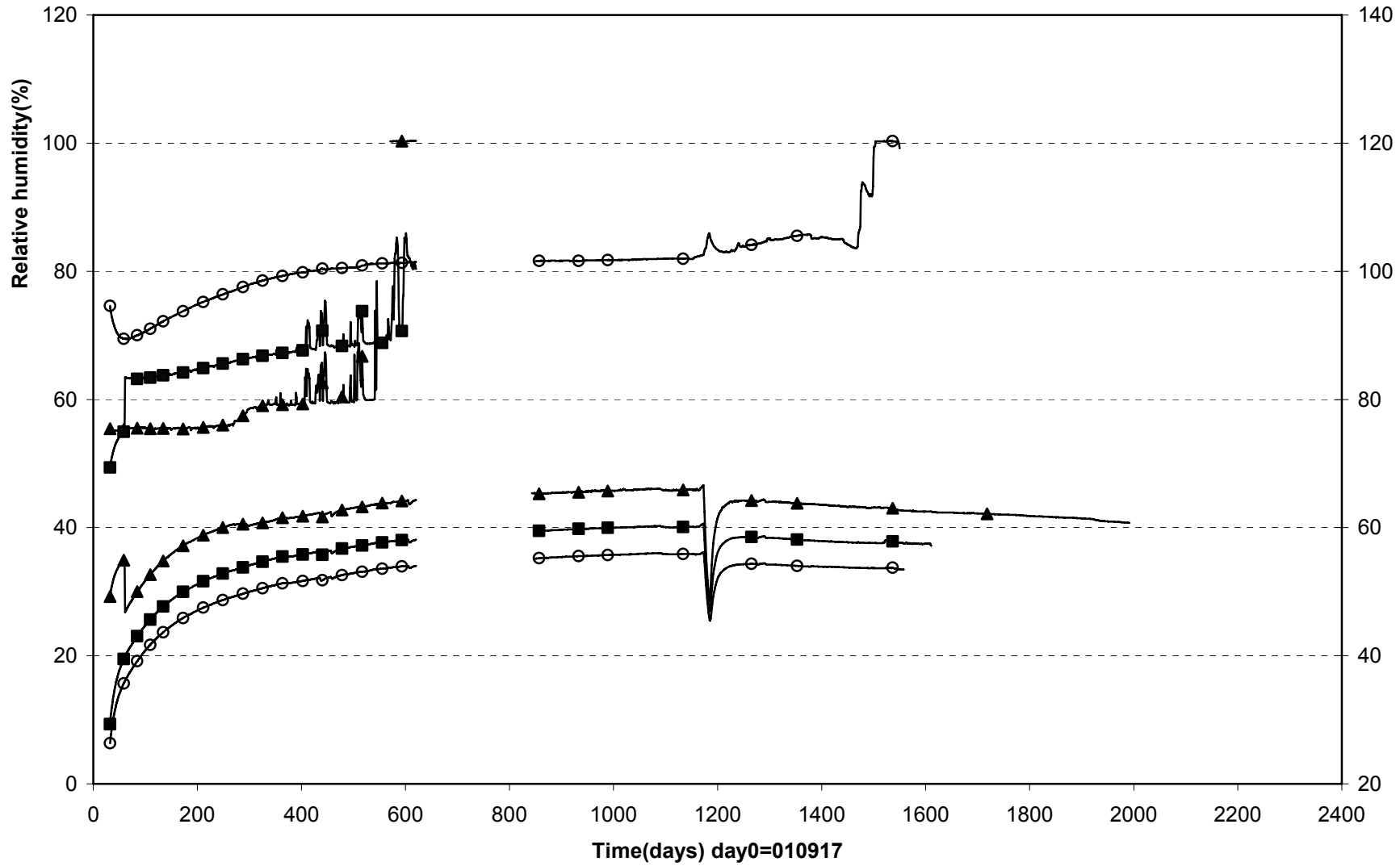

▲ WBU30010(0.245\170°\0.585) ■ WBU30011(0.245\170°\0.685) ○ WBU30012(0.245\170°\0.785)

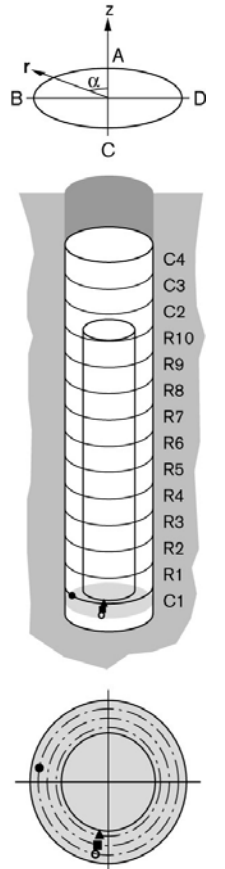

Prototype\Hole 3\Ring 5 (010917-081201)
 Relative humidity - Rotronic

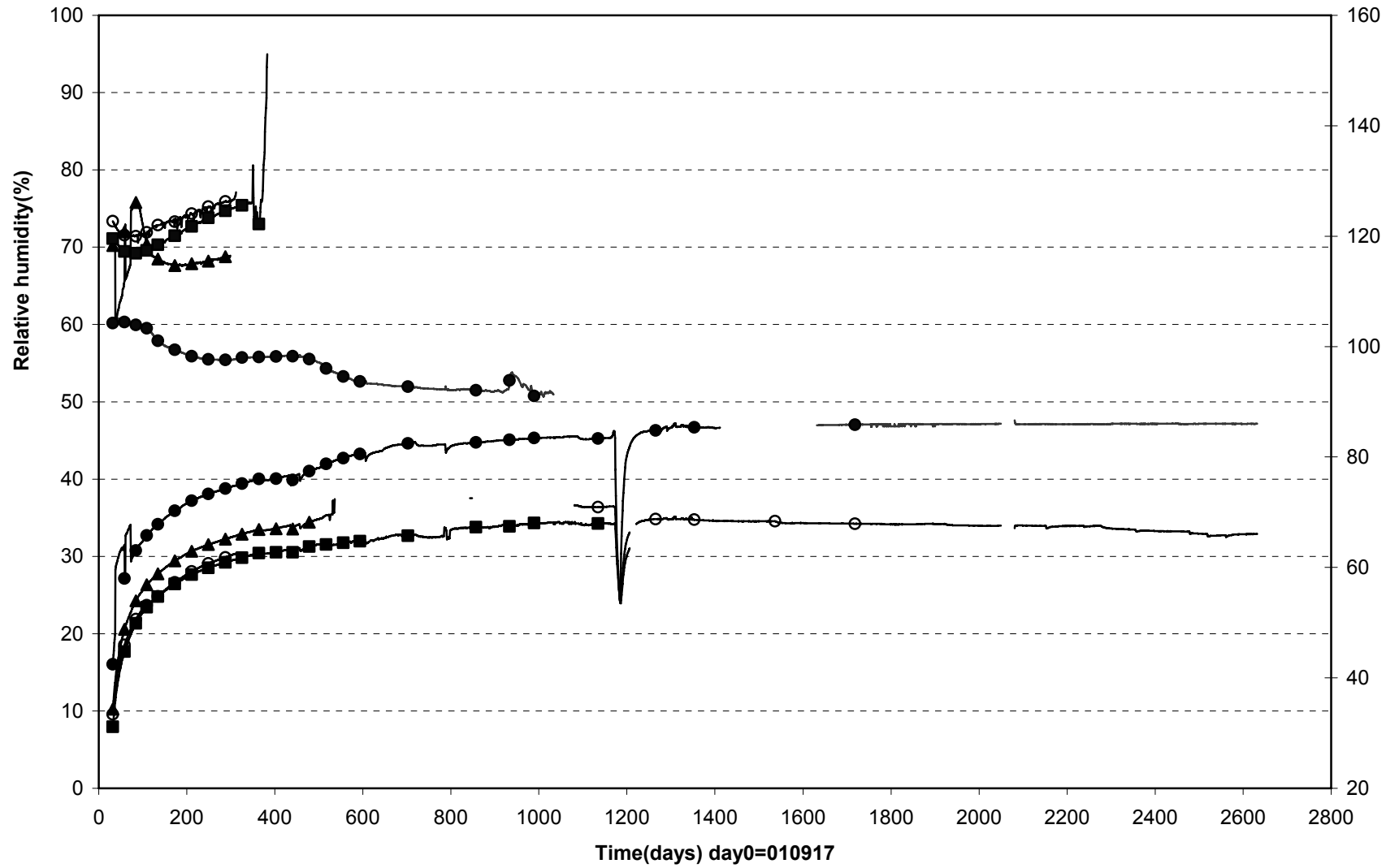

● WBU30016(2.750\80°\0.535) ▲ WBU30017(2.750\80°\0.685) ■ WBU30018(2.750\80°\0.785) ○ WBU30021(2.750\180°\0.785)

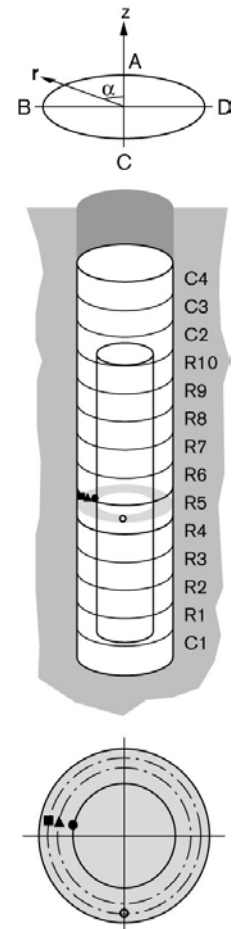

Prototype\Hole 3\Ring 10 (010917-081201)
 Relative humidity - Rotronic

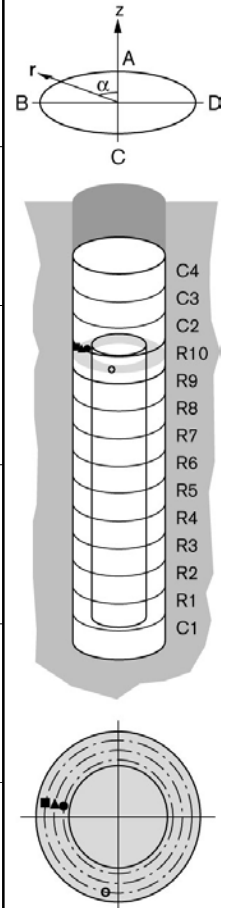
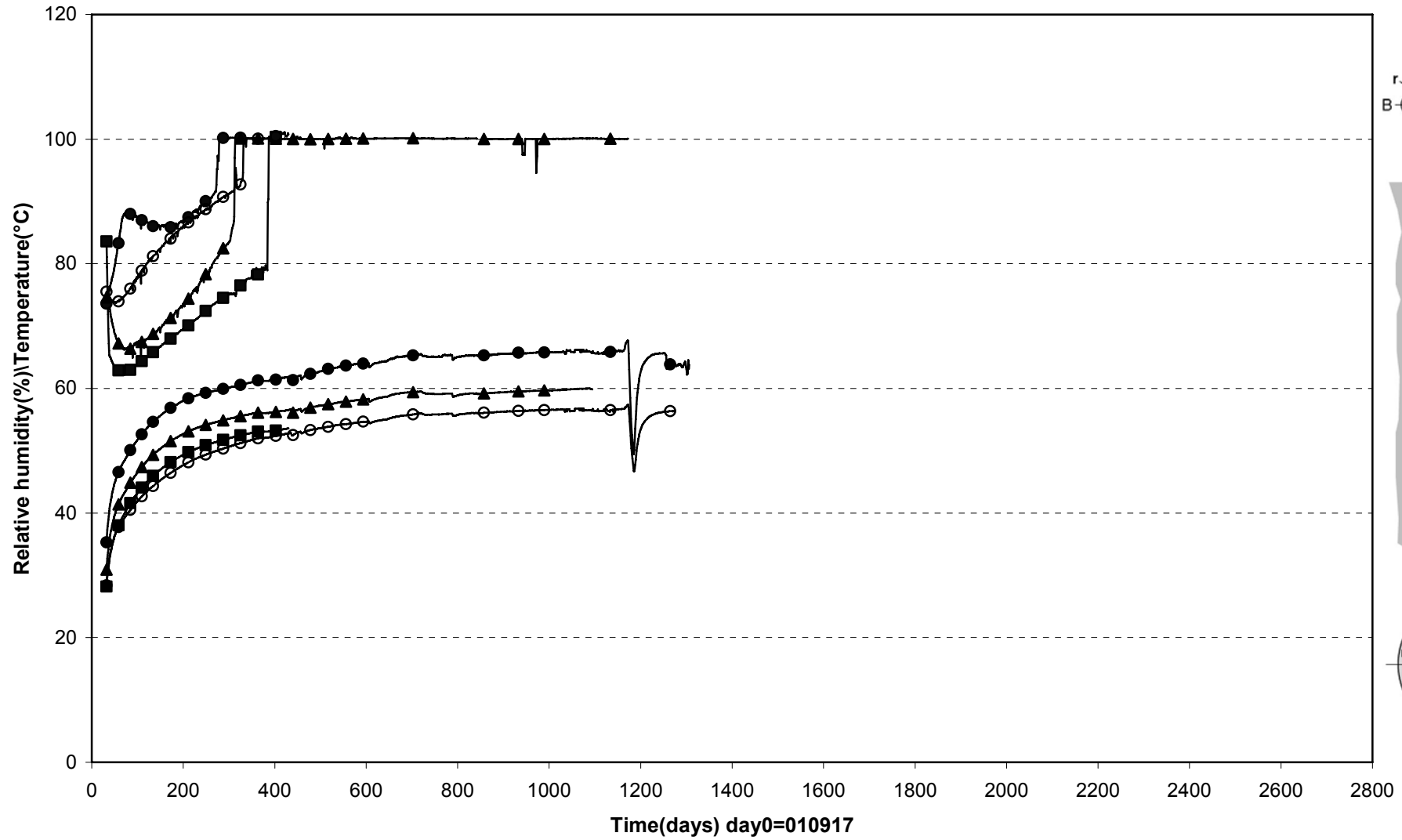

Prototype\Hole 3\Cyl.3 (010917-081201)
 Relative humidity - Rotronic

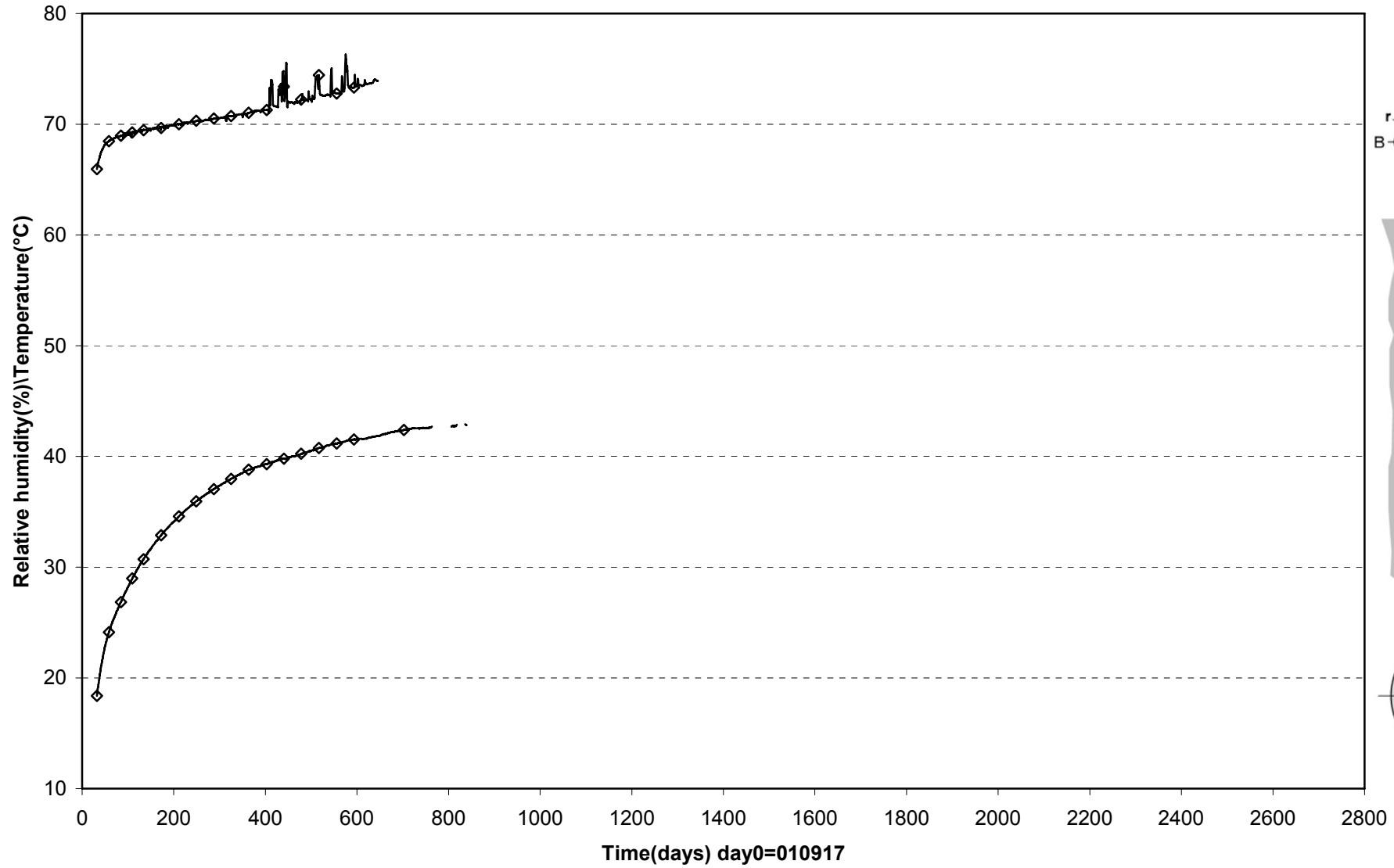

◇ WBU30035(6.314\180°\0.585)

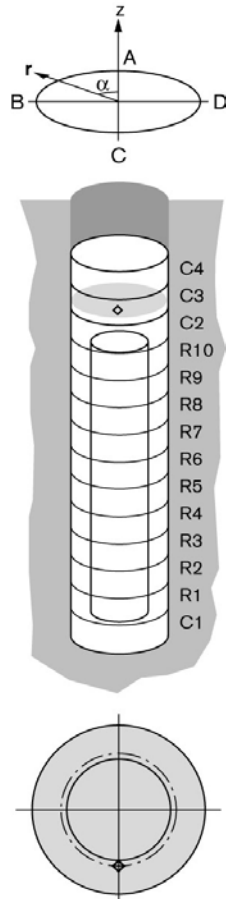

Prototype\Hole 3 (010917-081201)
Pore pressure - Geokon

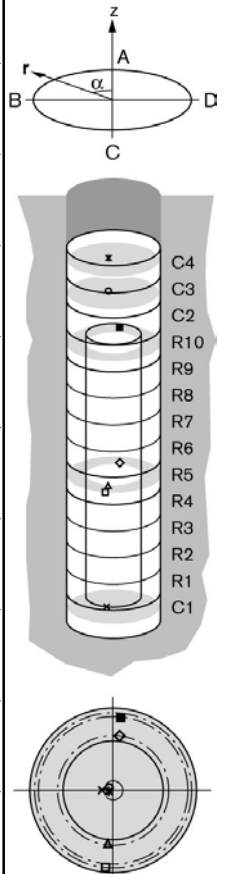
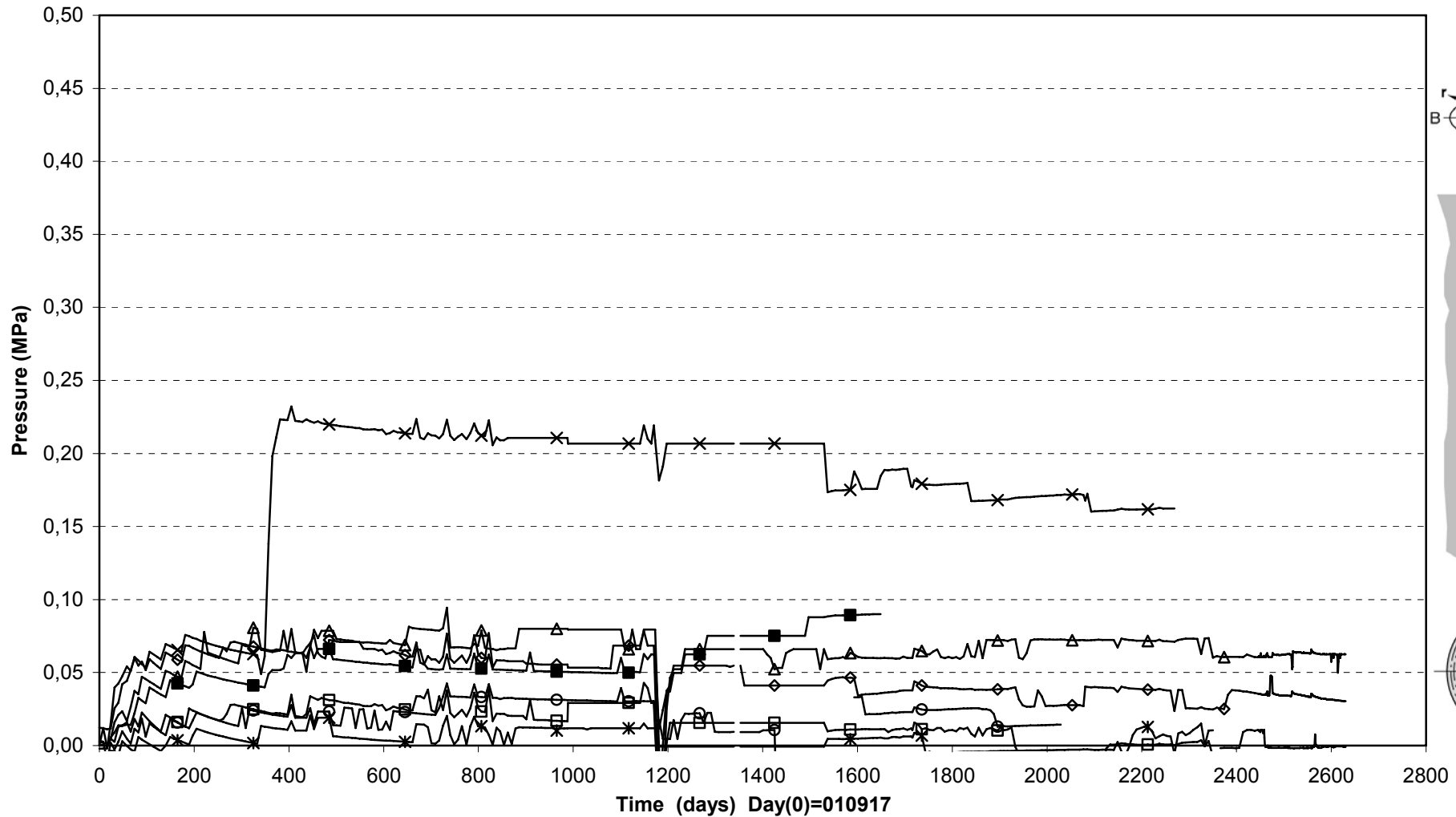

× UBU30002(0.245\90°\0.100)	◇ UBU30005(2.771\355°\0.585)	△ UBU30009(2.771\175°\0.535\in the slot)	□ UBU30010(2.771\175°\0.825\in the slot)
■ UBU30012(5.306\355°\0.785)	○ UBU30013(6.314\90°\0.050)	✱ UBU30014(6.910\90°\0.050)	

PrototypeHole 3 (010917-081201)
Pore pressure - Kulite

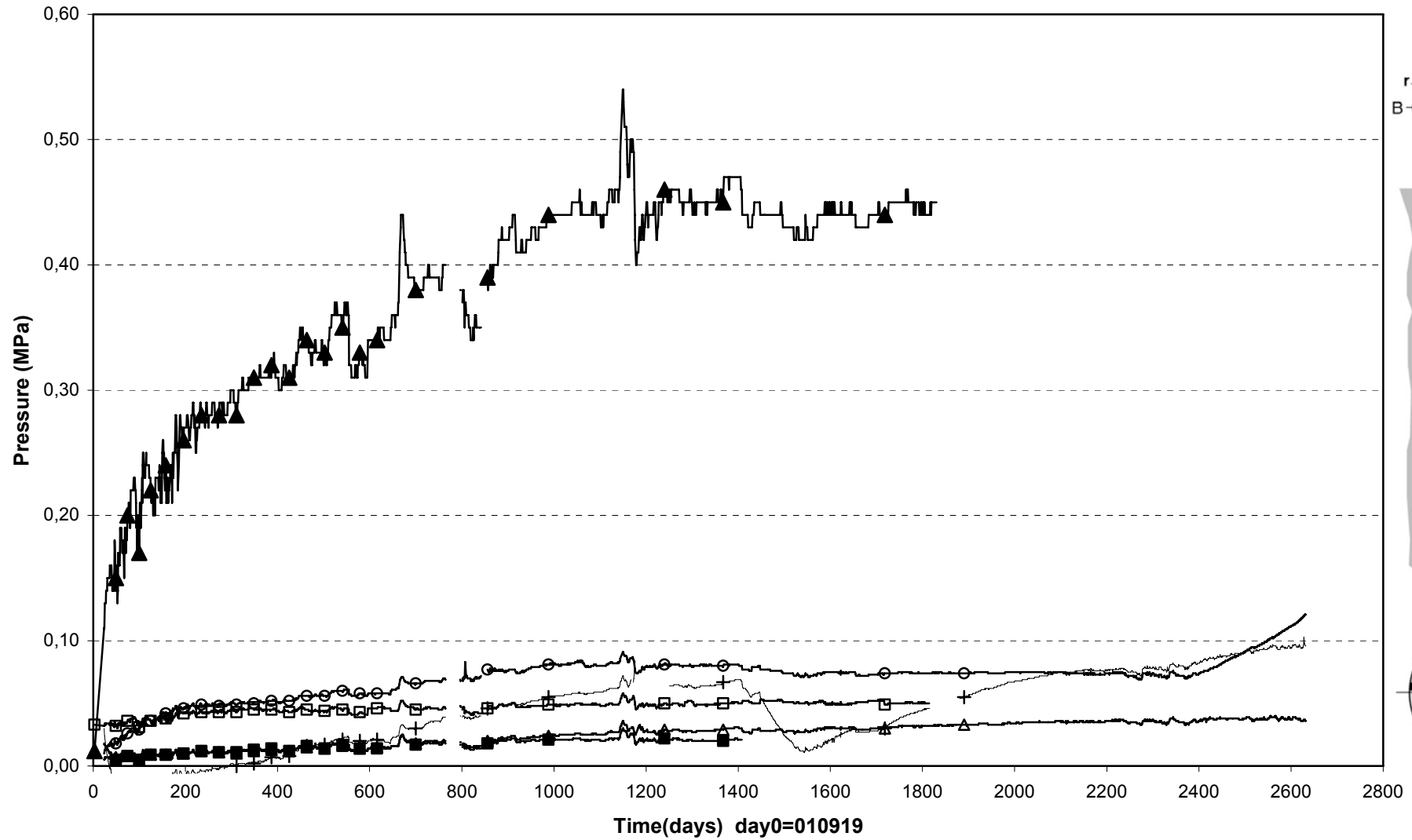

□ UBU30001(Cyl.1\90°\0.050)	▲ UBU30004(Cyl.1\355°\0.785)	○ UBU30006(Ring5\355°\0.785)
+ UBU30007(Ring.5\85°\0.535\In the slot)	■ UBU30008(Ring.5\85°\0.825\In the slot)	△ UBU300011(Ring10\355°\0.585)

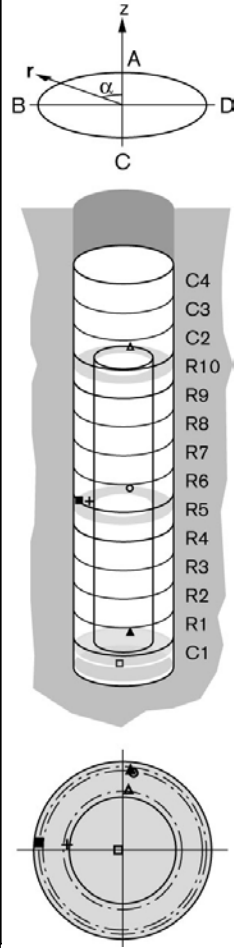

Prototype\Hole 3\Cyl.1 (010917-081201)
 Temperature - Pentronic

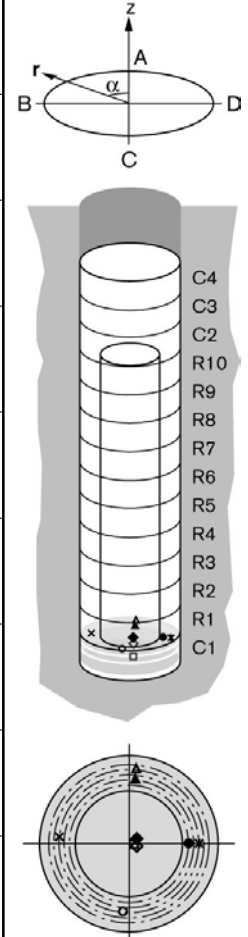
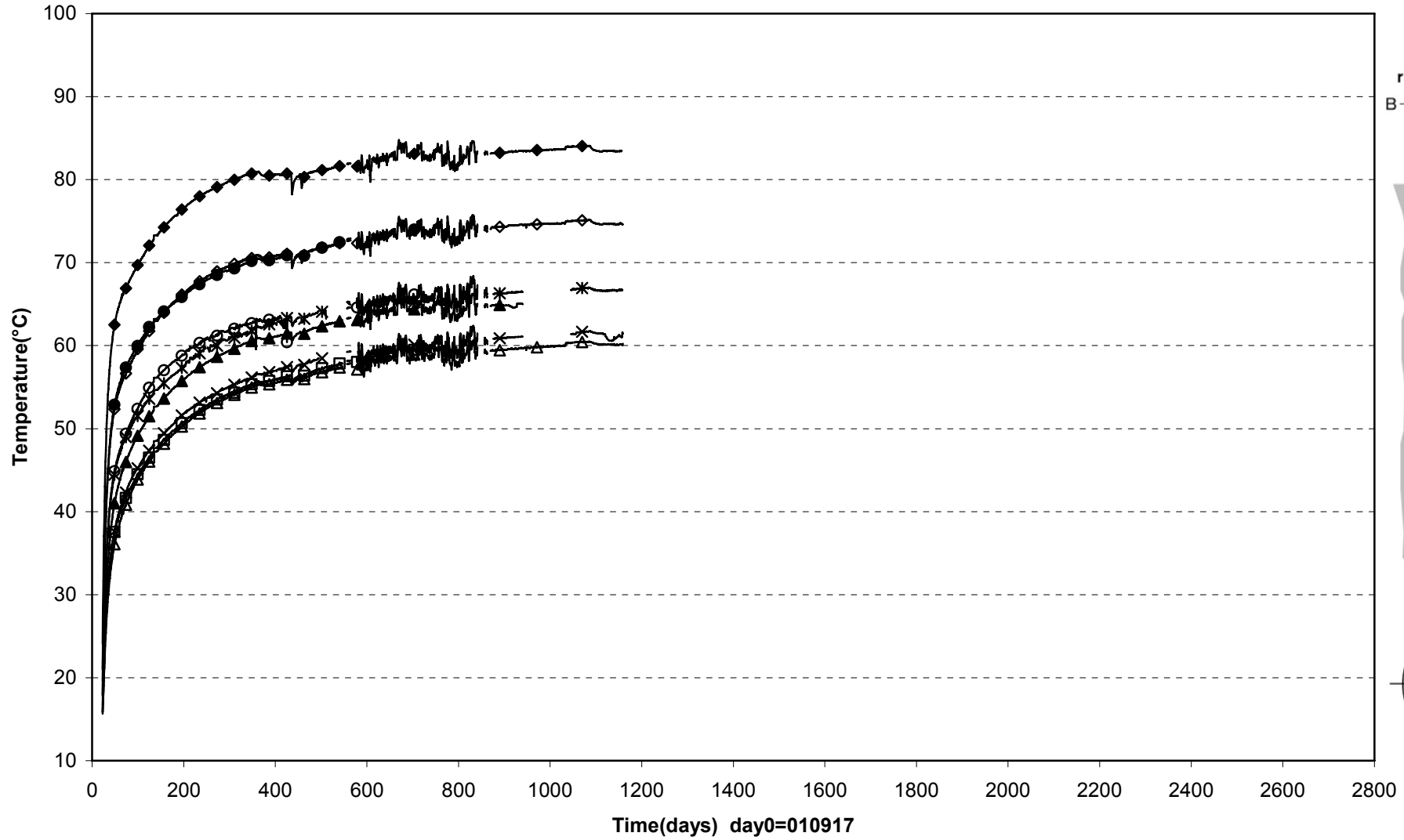

□ TBU30001(0.095\270°\0.050) ◇ TBU30002(0.295\270°\0.050) ◆ TBU30003(0.445\270°\0.050) ▲ TBU30004(Cyl.1\355°\0.635) △ TBU30005(Cyl.1\355°\0.735)
 × TBU30006(Cyl.1\85°\0.685) ○ TBU30007(Cyl.1\175°\0.685) ● TBU30008(Cyl.1\270°\0.585) ✖ TBU30009(Cyl.1\270°\0.685)

c

Prototype\Hole 3\Ring5 (010917-081201)
 Temperature - Pentronic

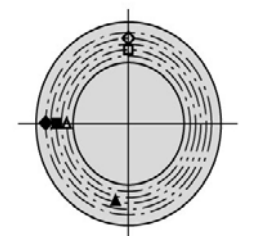
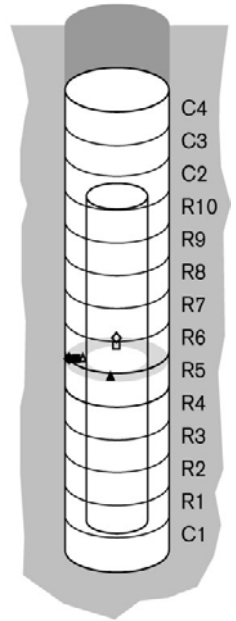
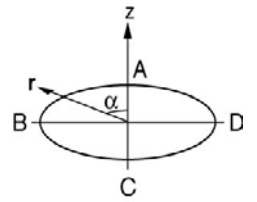
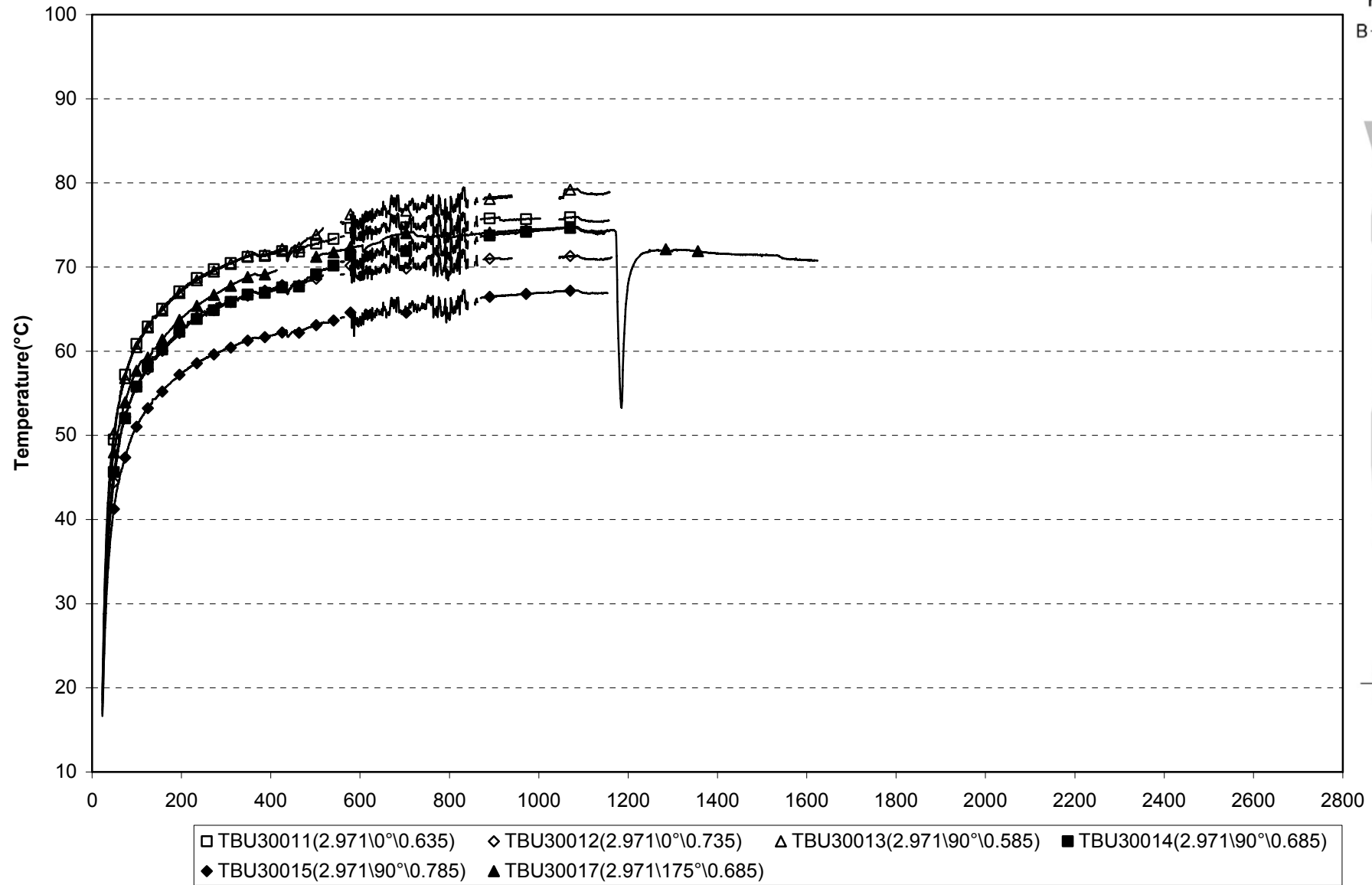

Prototype\Hole 3\Ring5 (010917-081201)
 Temperature - Pentronic

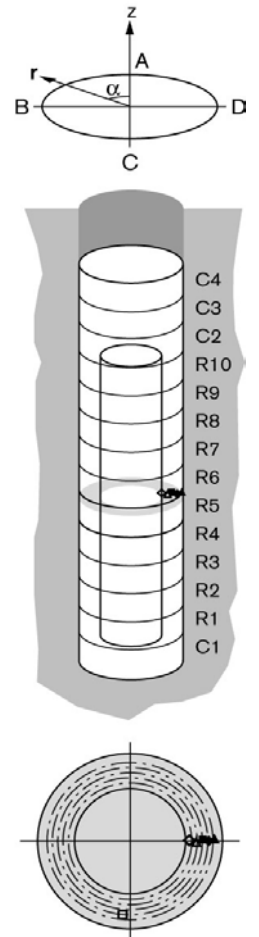
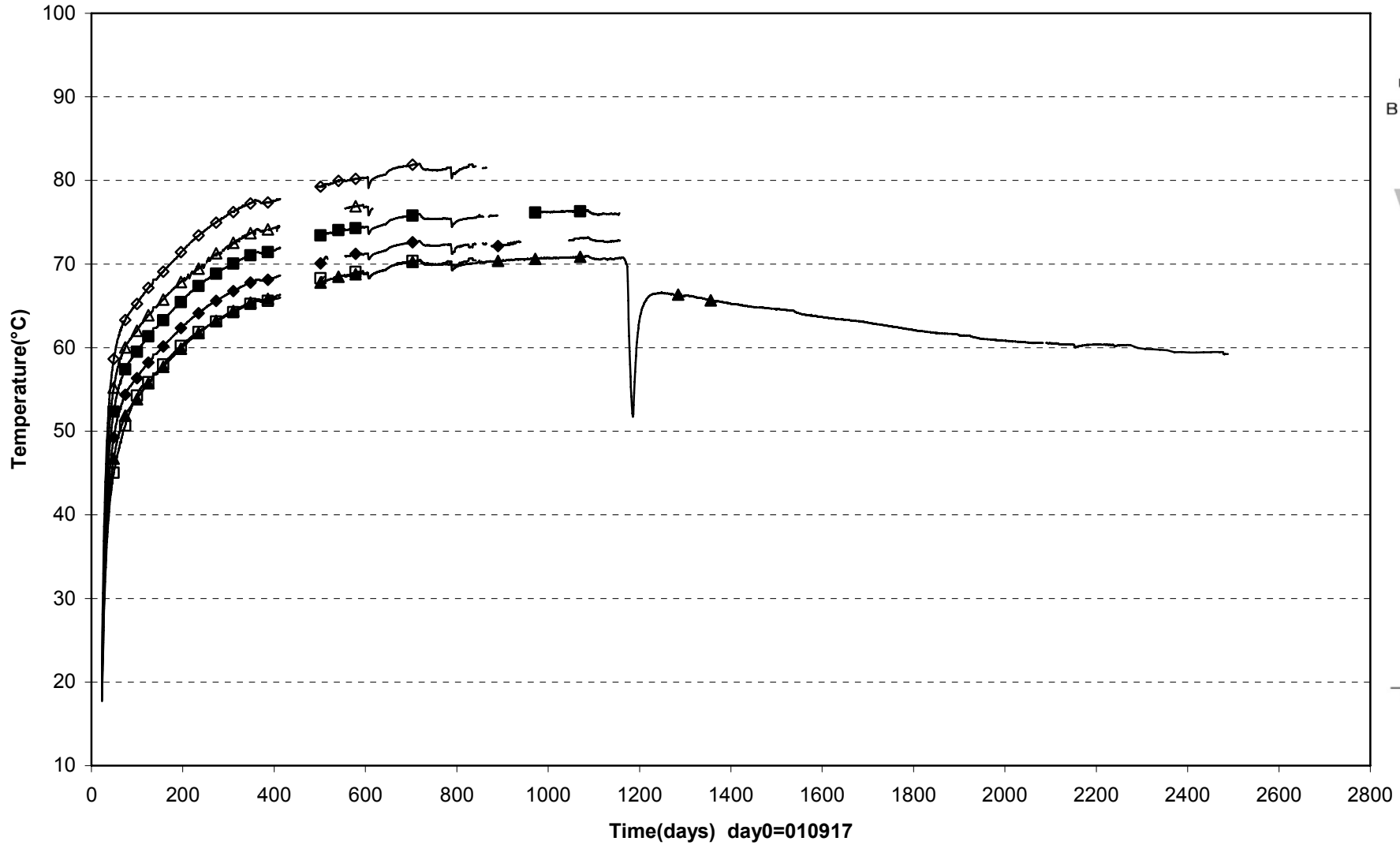

□ TBU30018(2.971\175°\0.735) ◇ TBU30019(2.971\270°\0.585) △ TBU30020(2.971\270°\0.635) ■ TBU30021(2.971\270°\0.685)
 ◆ TBU30022(2.971\270°\0.735) ▲ TBU30023(2.971\270°\0.785)

Prototype\Hole 3\Ring10 (010917-081201)
 Temperature - Pentronic

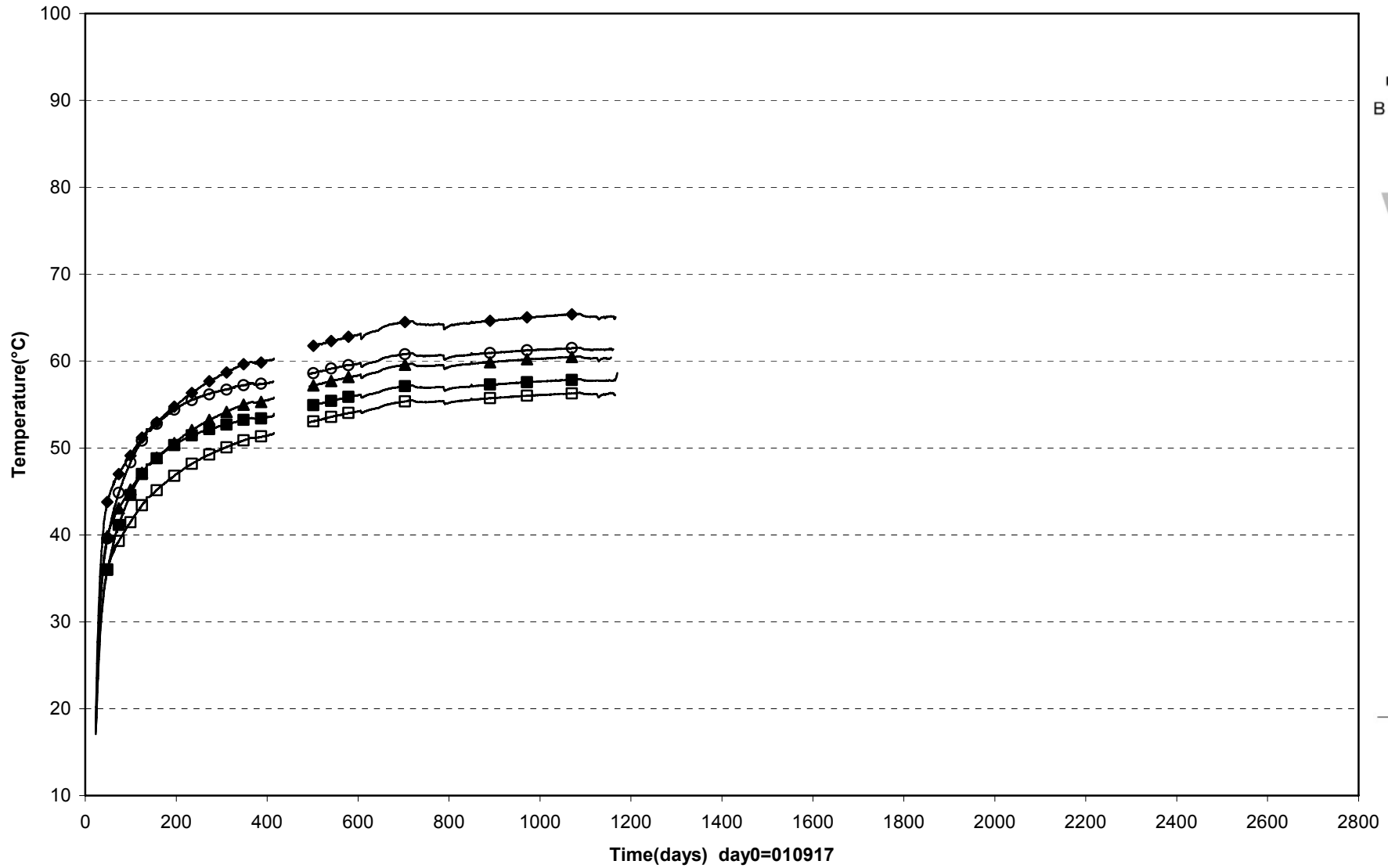

○ TBU30024(5.504\0°\0.635) ■ TBU30025(5.504\0°\0.735) ◆ TBU30026(5.504\270°\0.585) ▲ TBU30027(5.504\270°\0.685) □ TBU30028(5.504\270°\0.785)

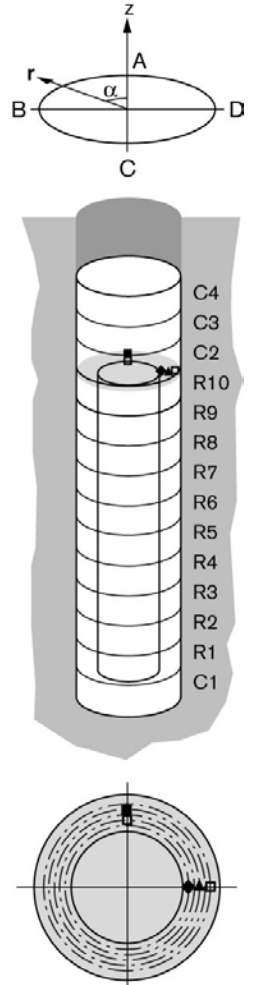

Prototype\Hole 3\Cyl.3 and Cyl.4 (010917-080121)
 Temperature - Pentronic

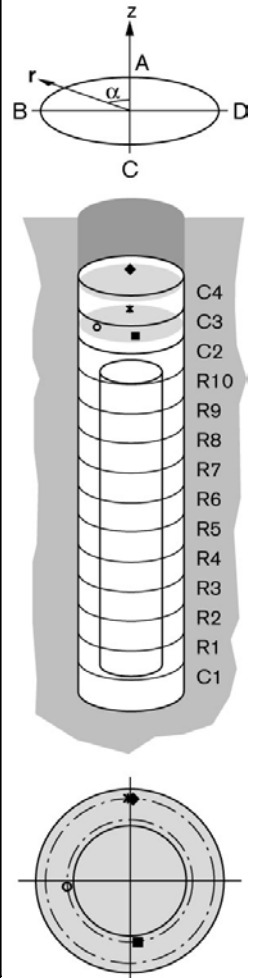
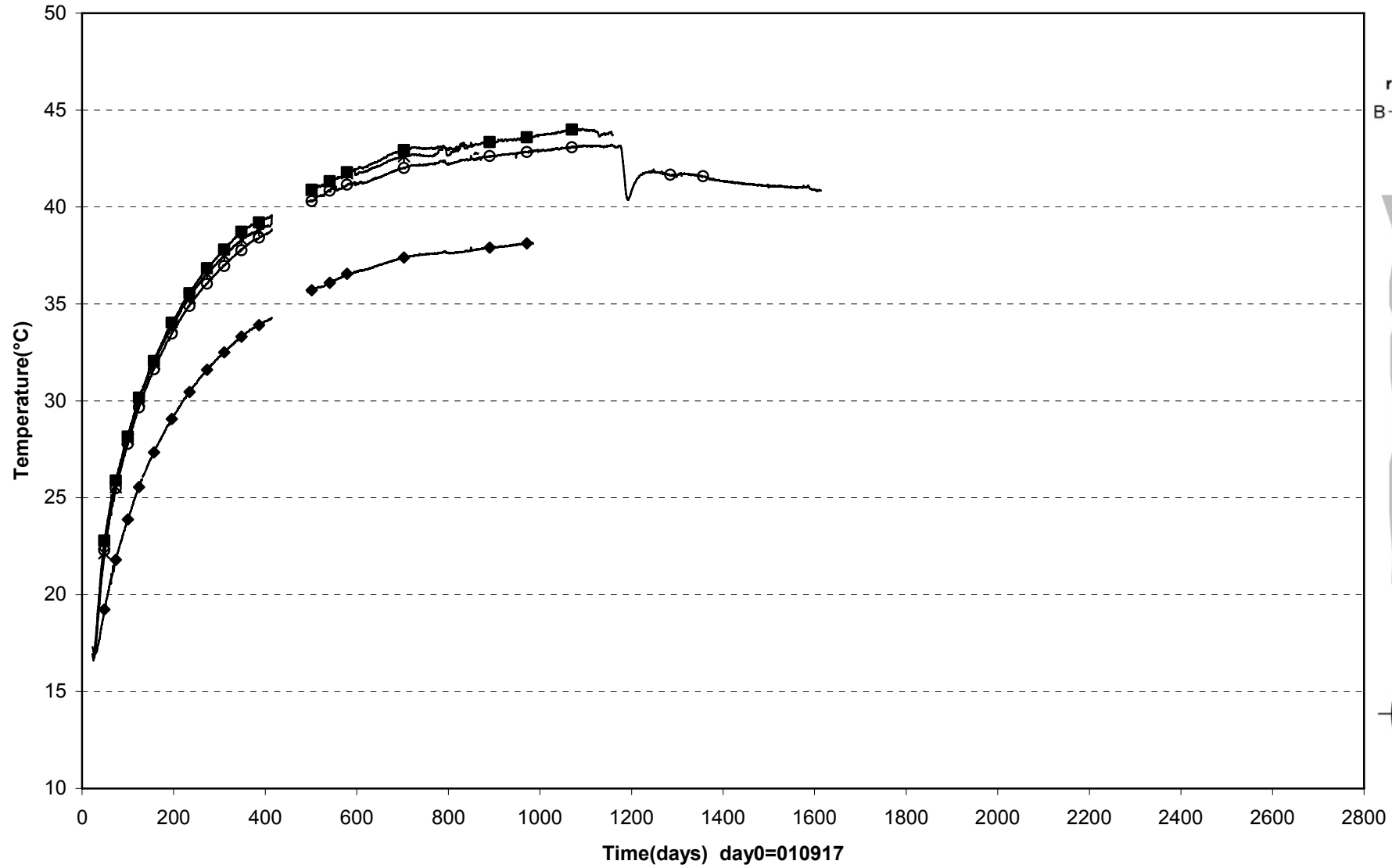

Prototype\Hole 3 (010917-081201)
 Tempreture - Geokon

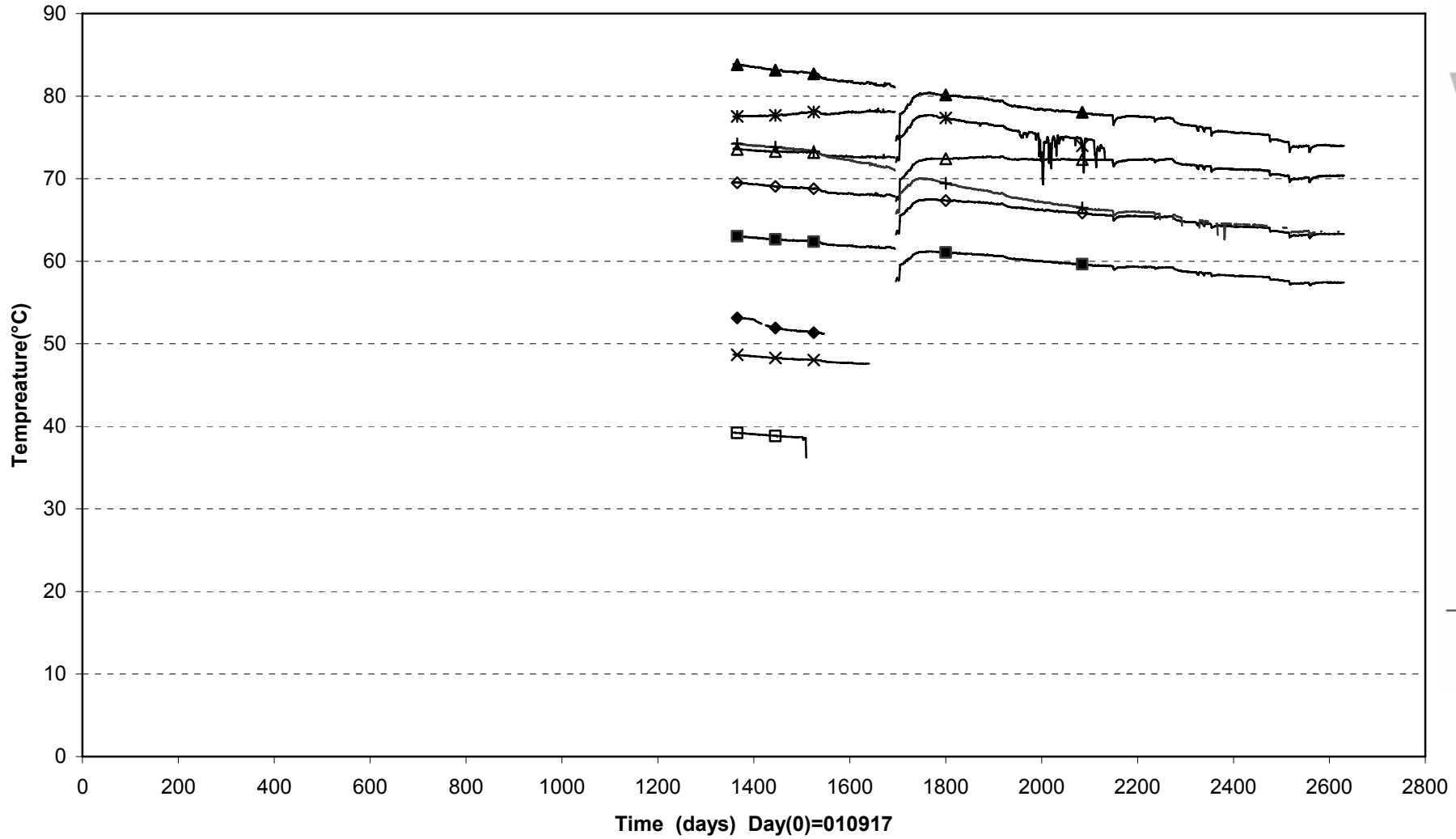

✱ PBU30001(0\0°\0)	▲ PBU30002(0.495\0°\0.100)	◇ PBU30008(0.495\185°\0.635)	■ PBU30009(0.495\195°\0.735)	✱ PBU30013(2.771\95°\0.585)
△ PBU30015(3.021\185°\0.535)	+ PBU30017(5.556\0°\0.050)	◆ PBU30022(5.556\100°\0.735)	□ PBU30026(6.654\5°\0.585)	

Prototype\Hole 3 (010917-081201)
 Temperature - Geokon

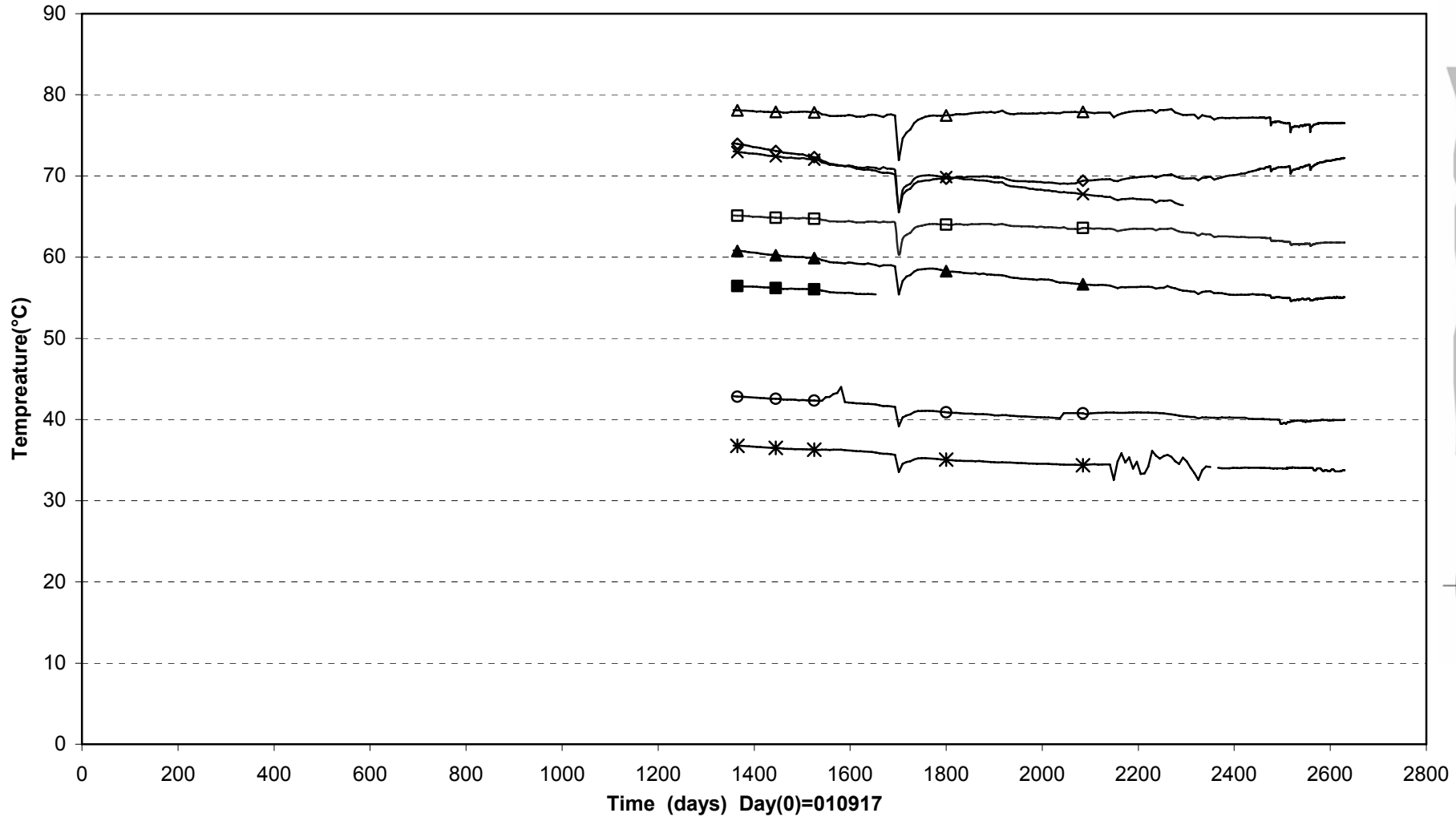

× UBU30002(0.245\90°\0.100)	▲ UBU30003(0.335\355°\0.585)	◇ UBU30005(2.771\355°\0.585)	△ UBU30009(2.771\175°\0.535\in the slot)
□ UBU30010(2.771\175°\0.825\in the slot)	■ UBU30012(5.306\355°\0.785)	○ UBU30013(6.314\90°\0.050)	✕ UBU30014(6.910\90°\0.050)

Prototype\Rock\Hole 3 (010917-081201)
 Temperature - Pentronic

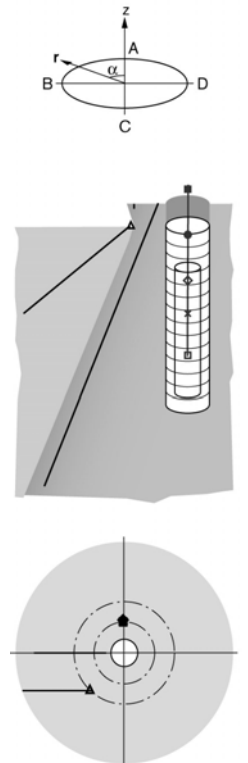
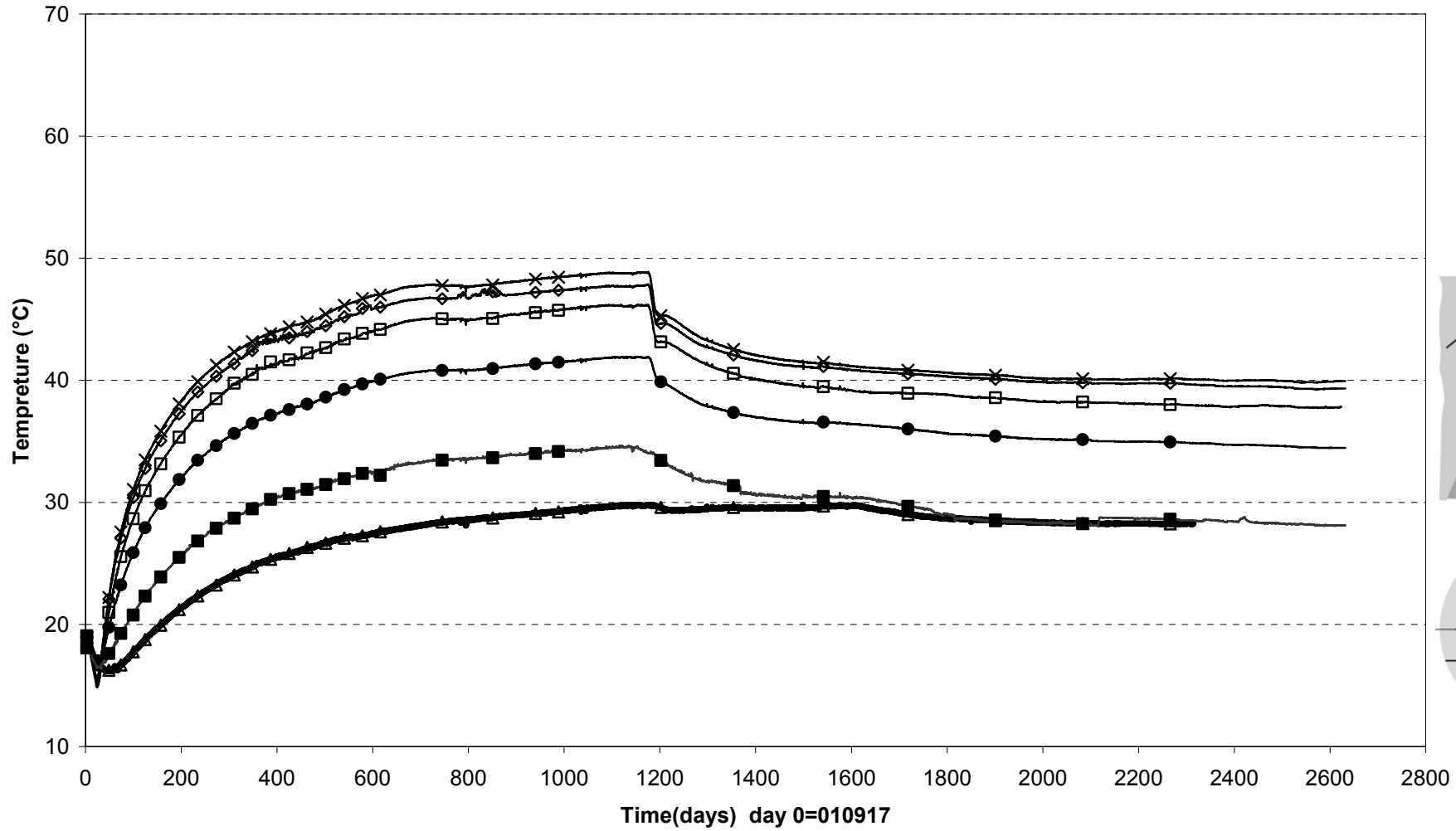

Prototype\Rock\Hole 3 (010917-081201)
 Temperature - Pentronic

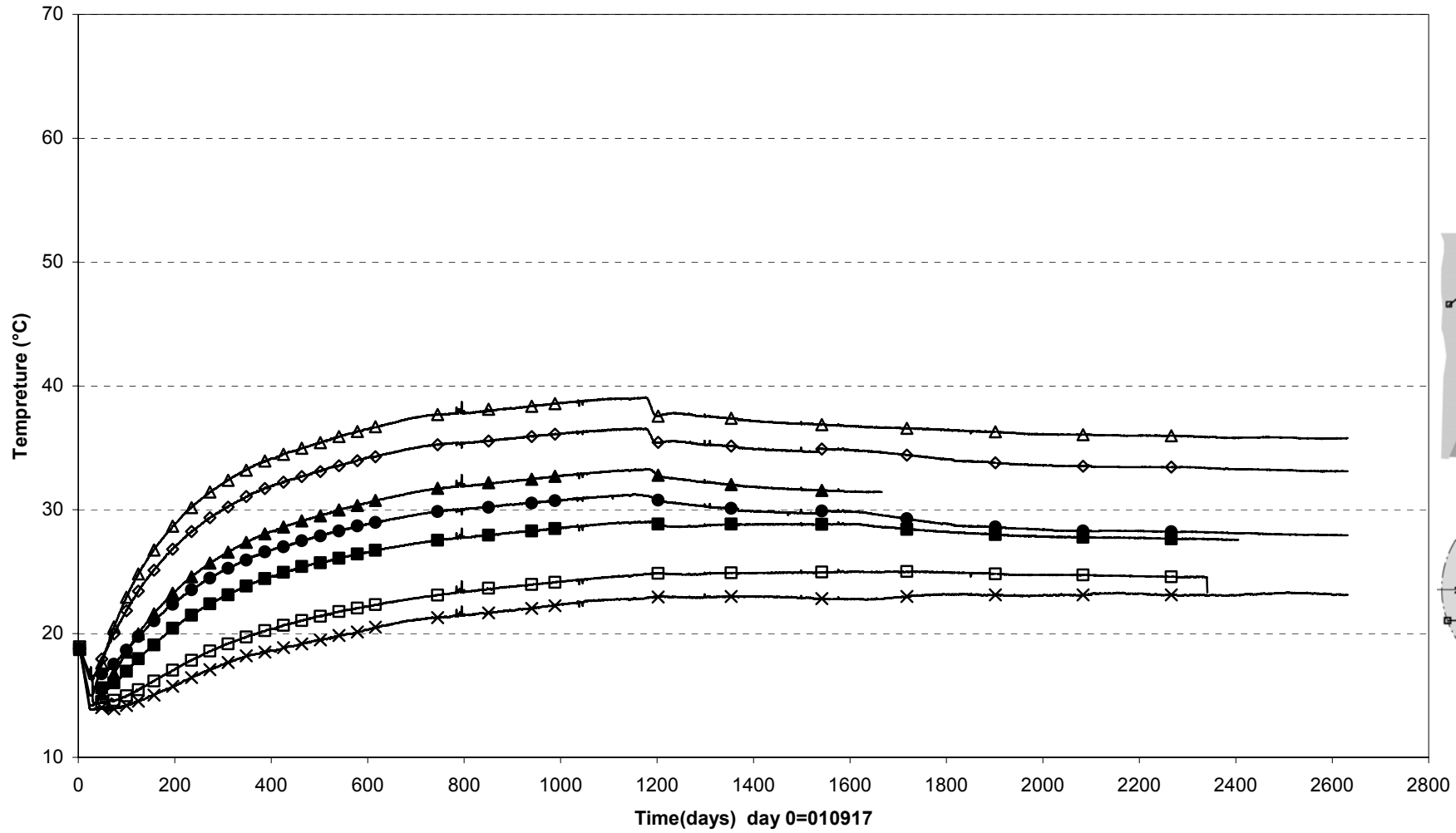

● TROA2330(7.924\90°\2.169)	◇ TROA2320 (6.632\90°\1.787)	□ TROA2310(4.640\109°\7.111)	■ TROA2440 (7.174\124°\4.088)
△ TROA2430 (4.319\90°\2.737)	▲ TROA2420(1.451\89°\3.914)	× TROA2410(-3.295\89°\5.861)	

Prototype\Hole 3\ On canister top (010917-081201)
Temperature - Pentronic

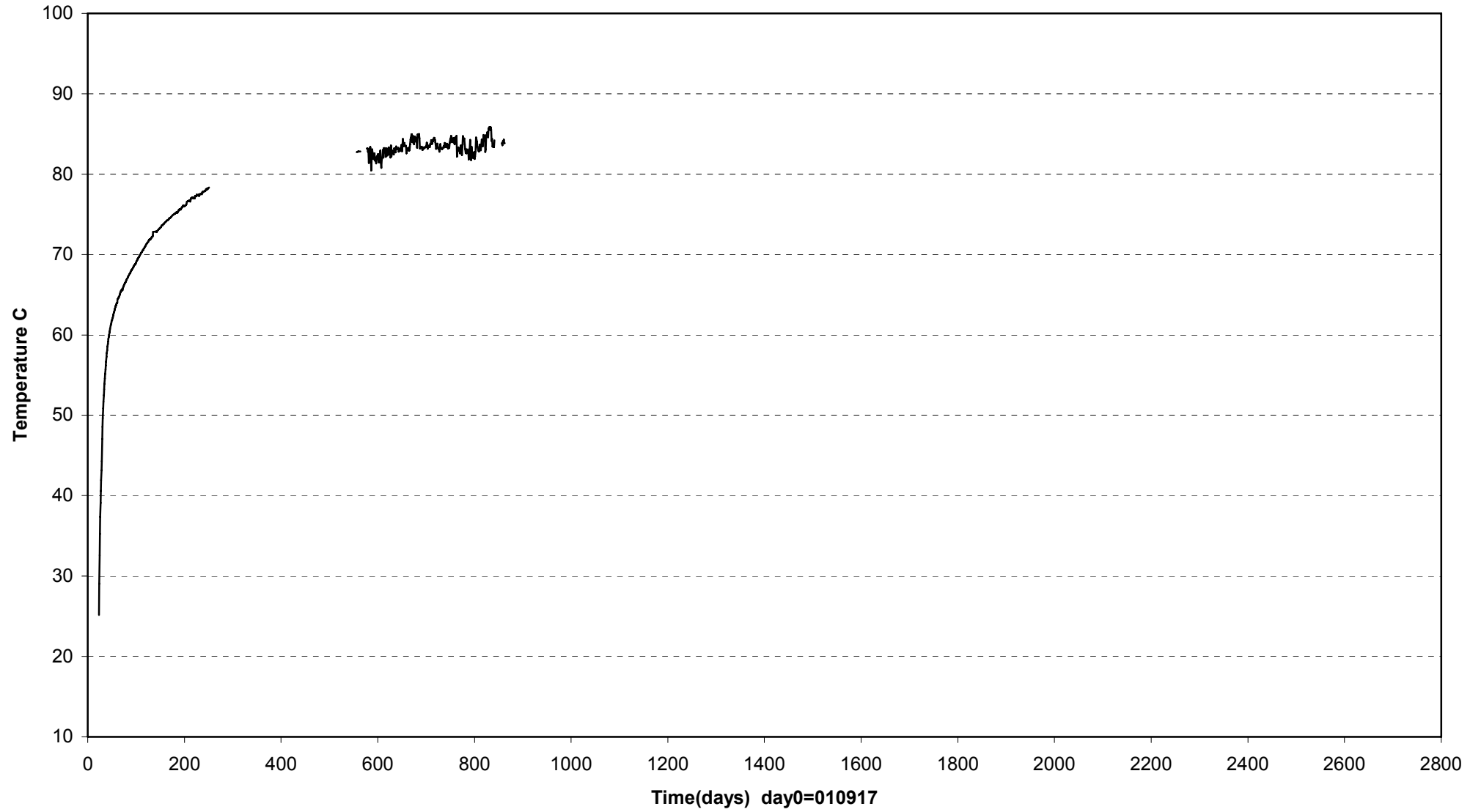

— TBU30016(5394\329°\410)-On canister top)

Prototype\ Hole 3 (010917-081201)
Canister power

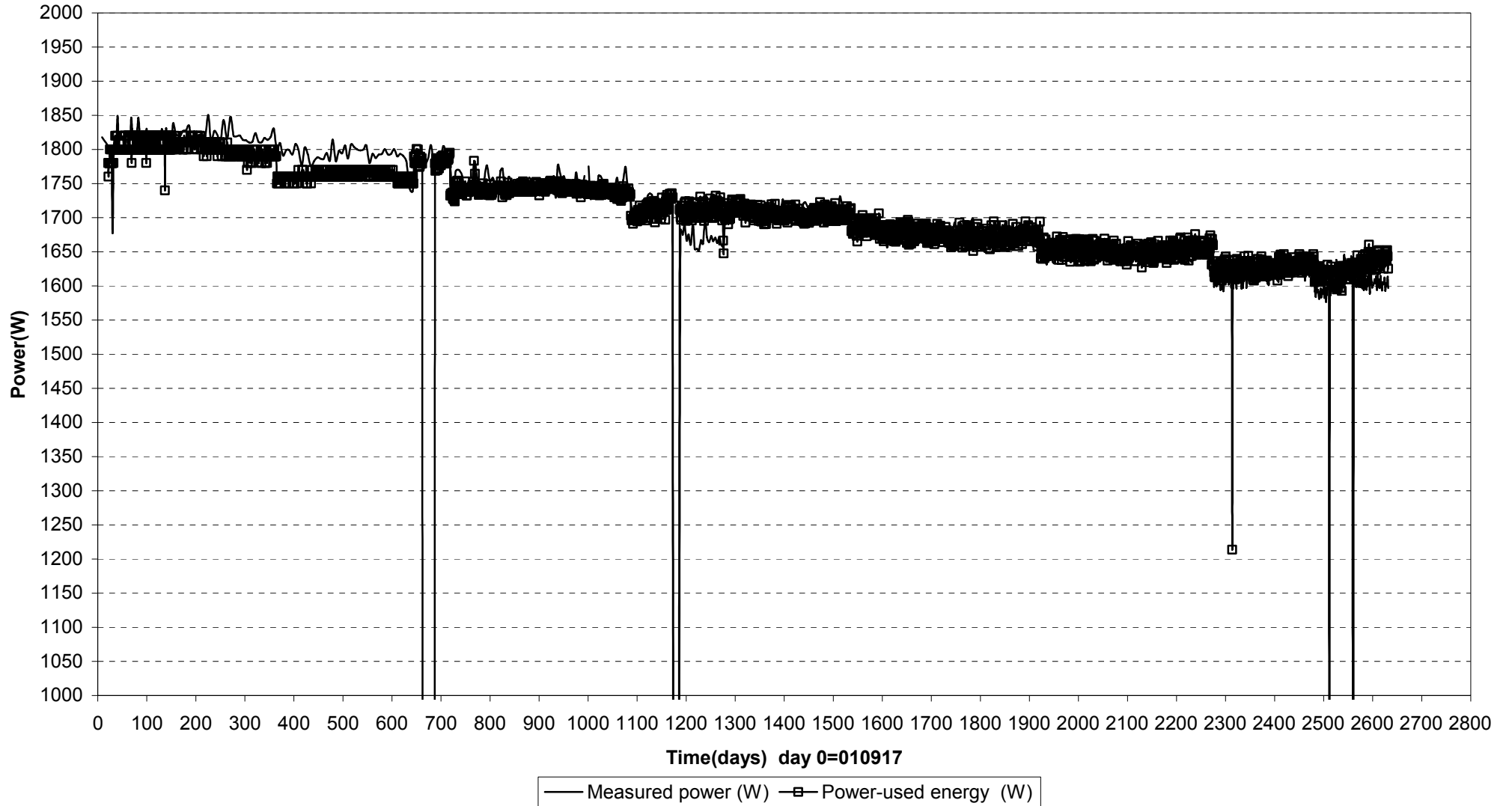

Prototype\ Hole 3 \Canister (010917-070601)
 Max. temperature on the canister surface - Optical fibre cables

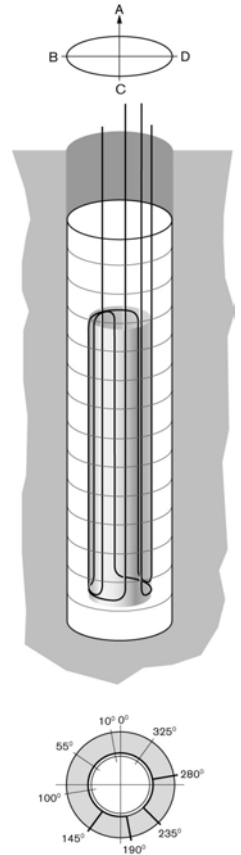
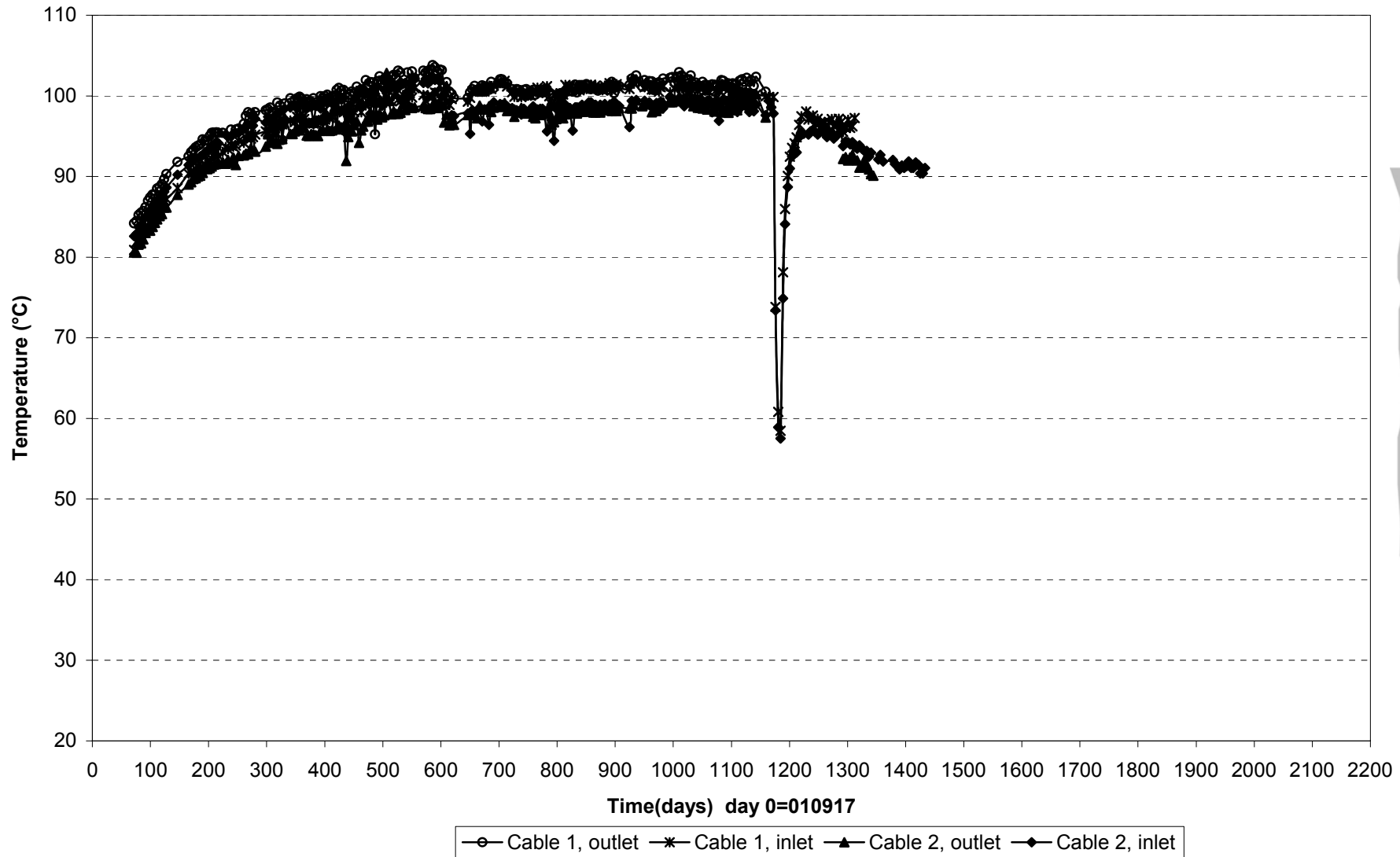

Prototype\ Hole 3 \Canister (050601)
Temperature profile on the canister surface - Optical fiber cables

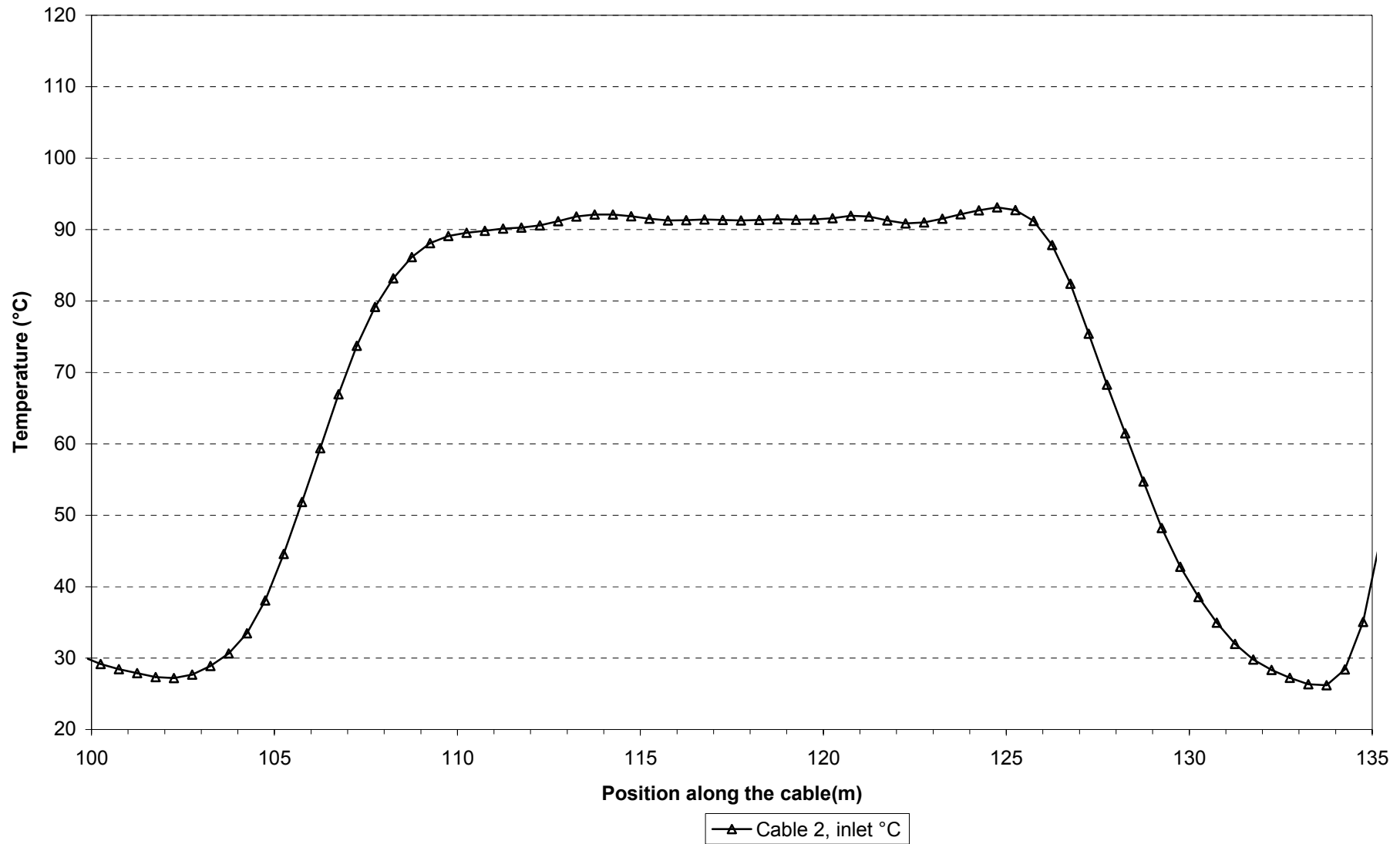

Appendix 3

Dep. holes 2 and 4

Prototype\Rock\Hole 2 (010917-081201)
 Temperature - Pentronic

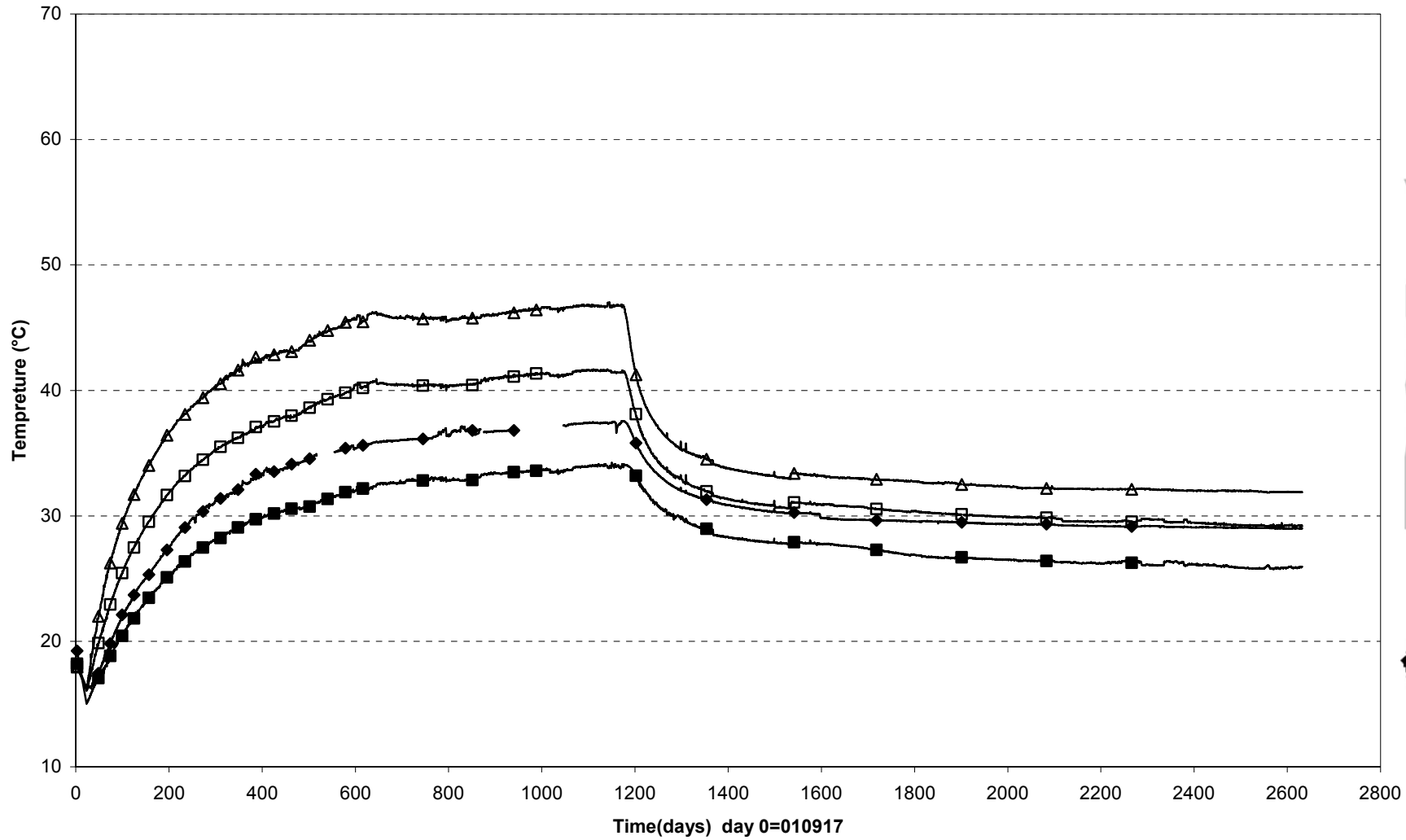

TROA1840(7.587\180°\2.404)
 TROA1830 (6.087\180°\2.427)
 TROA1820(2.138\179°\2.490)
 TROA1810 (-1.162\179°\2.542)

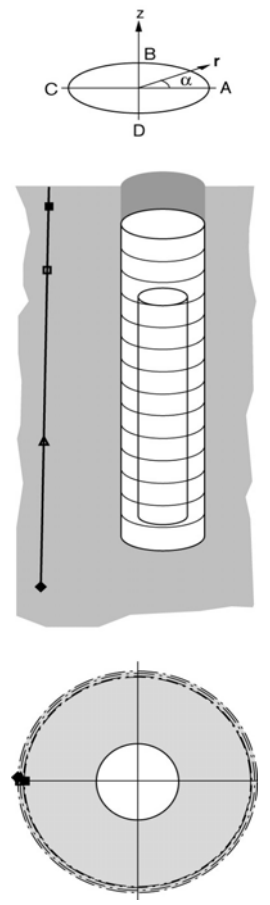

Prototype\ Hole 2 (010917-081201)
Canister power

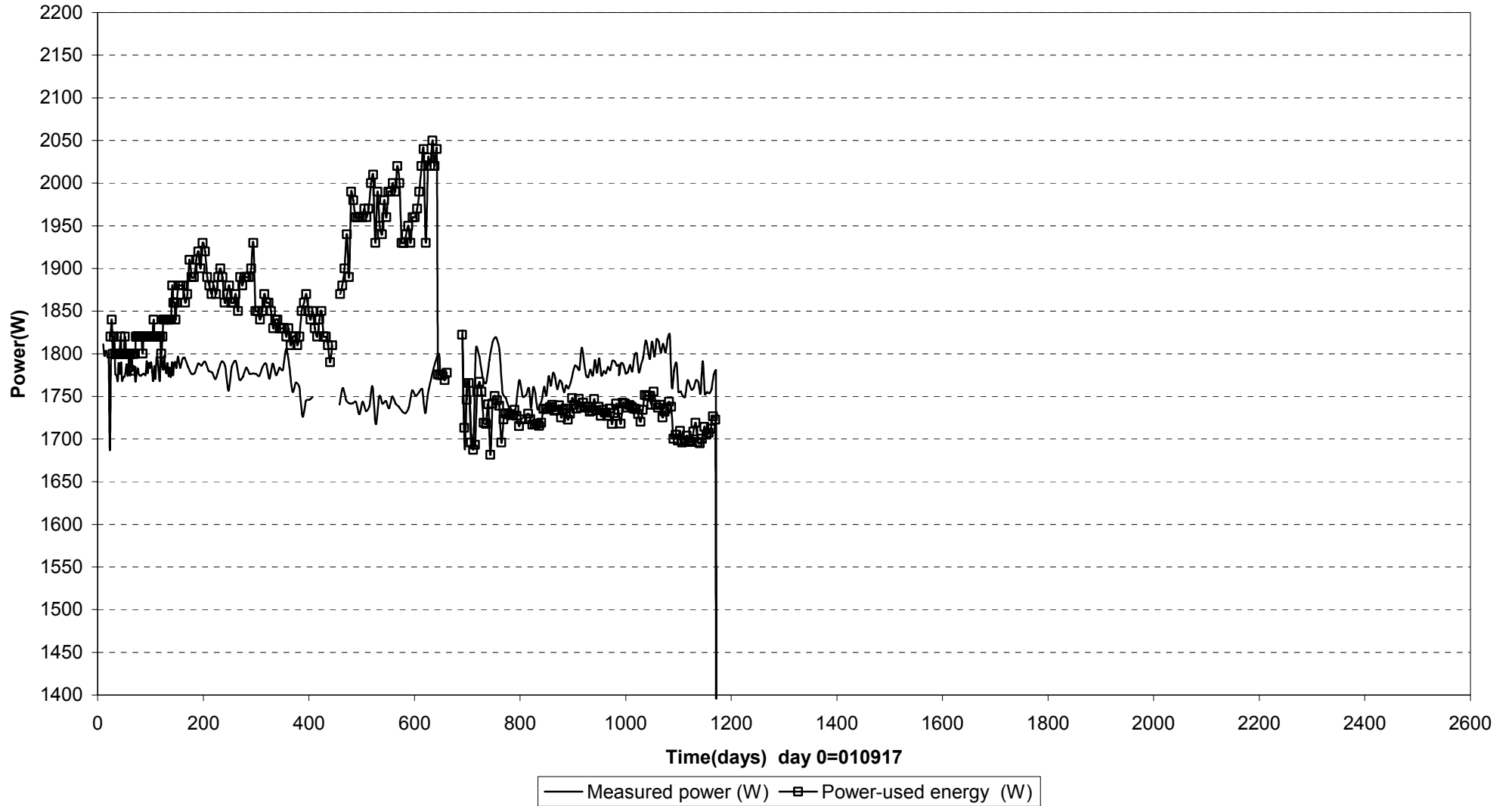

Prototype\ Hole 2 \Canister (010917-070601)
 Max. temperature on the canister surface - Optical fiber cables

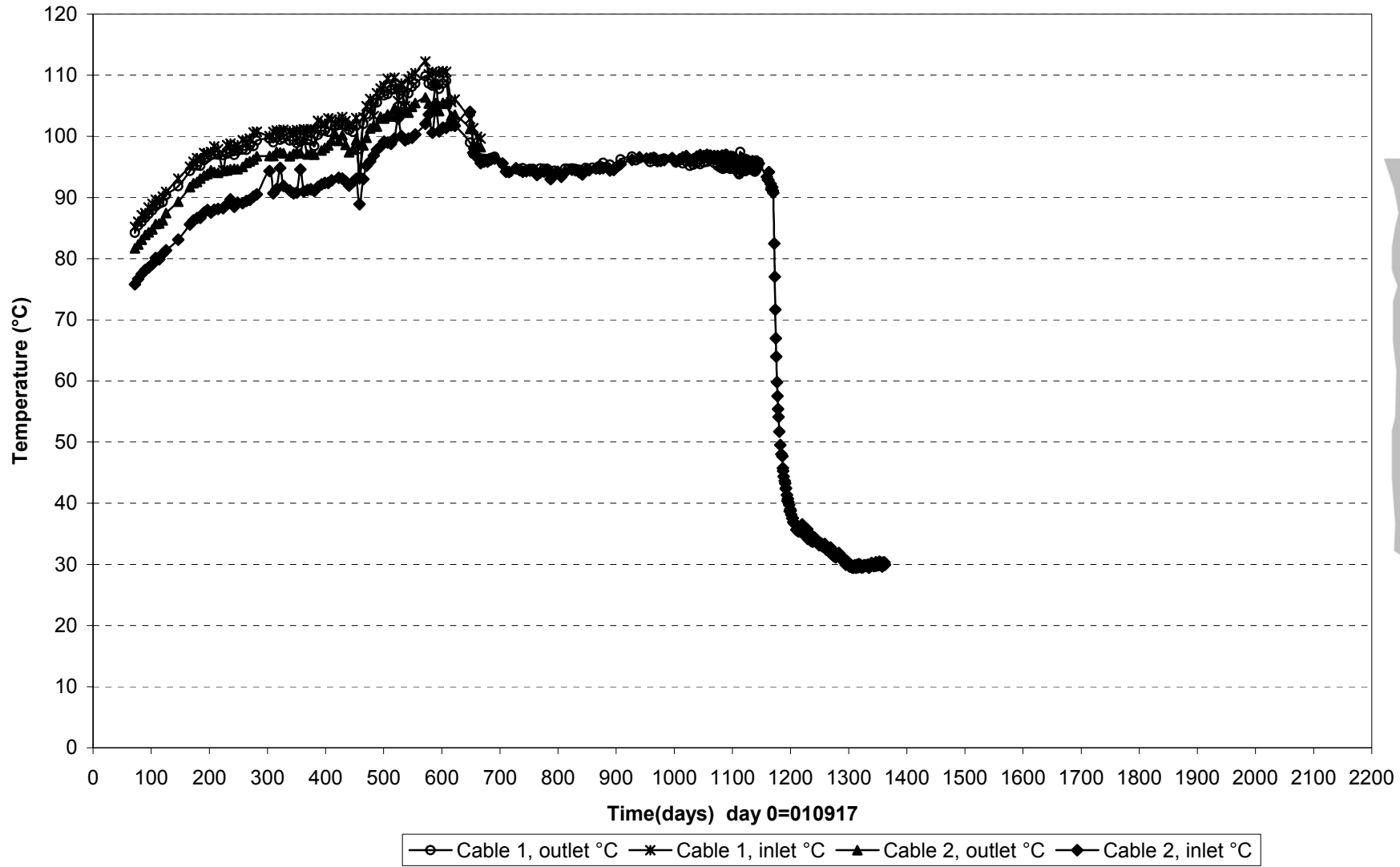

Prototype\ Hole 2 \Canister (050601)
Temperature profile on the canister surface - Optical fiber cables

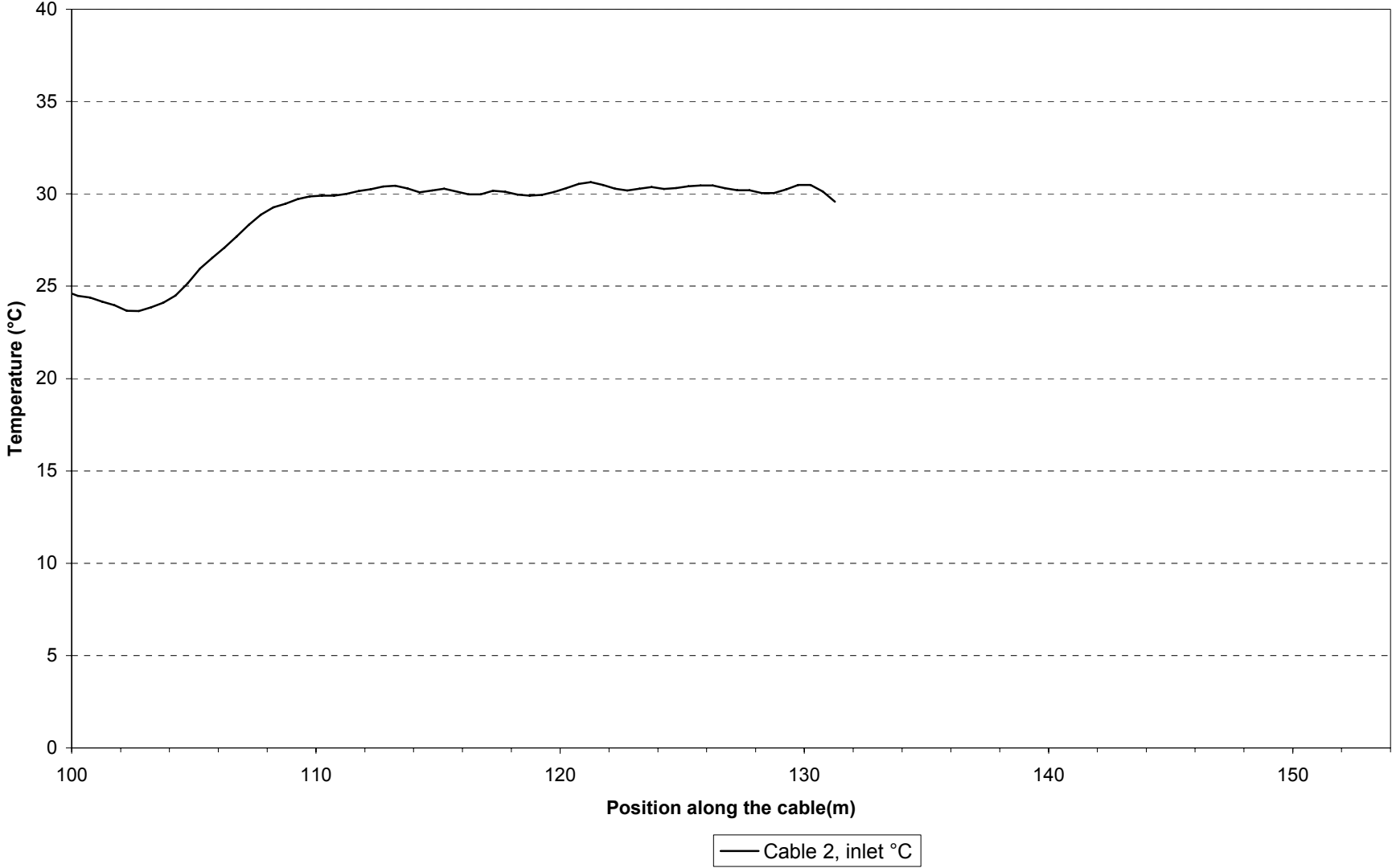

Prototype\Hole 2 \Canister top (010917-081201)
Temperature - Pentronic

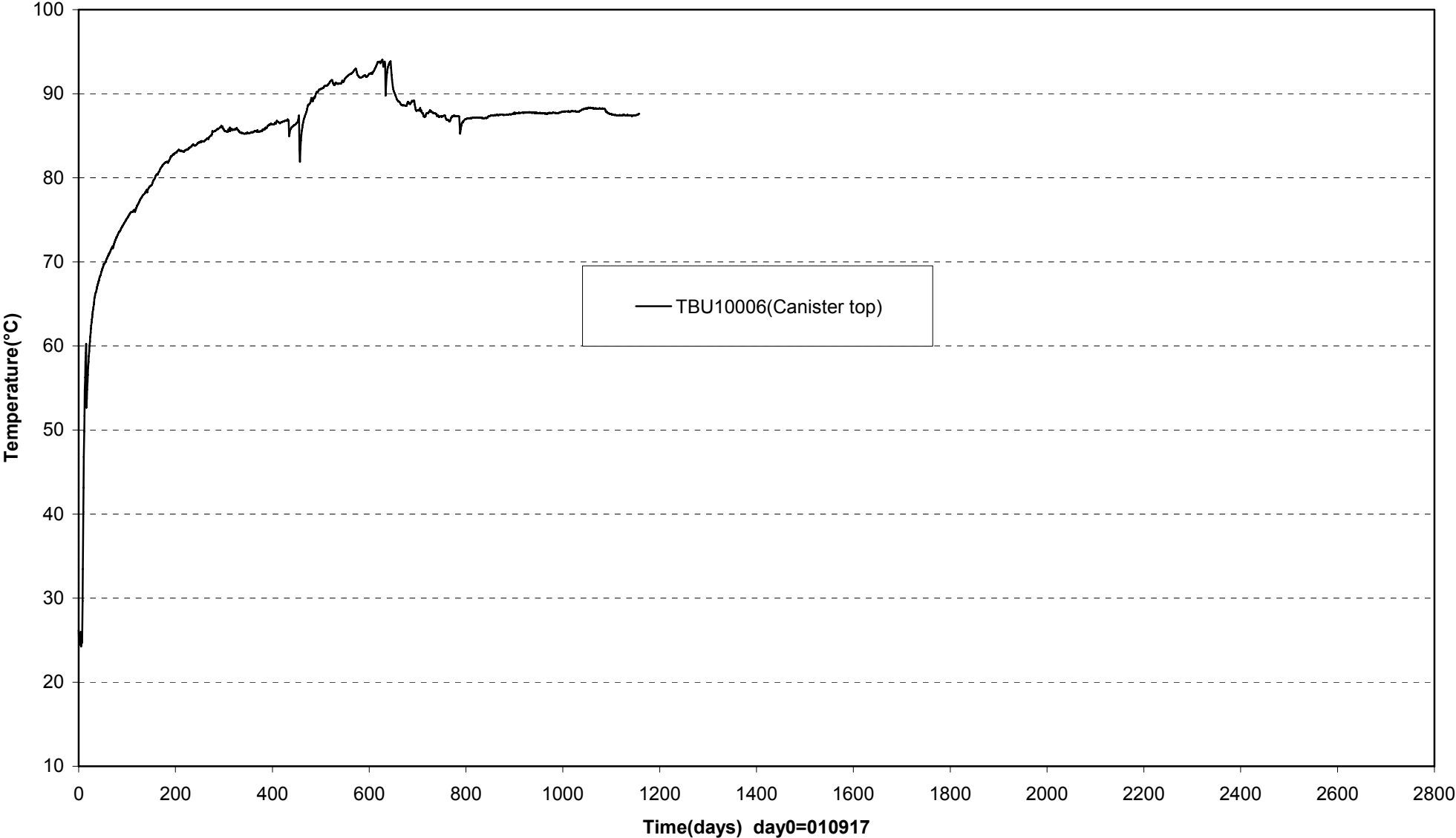

Prototype\Rock\Hole 4 (010917-081201)
 Temperature - Pentronic

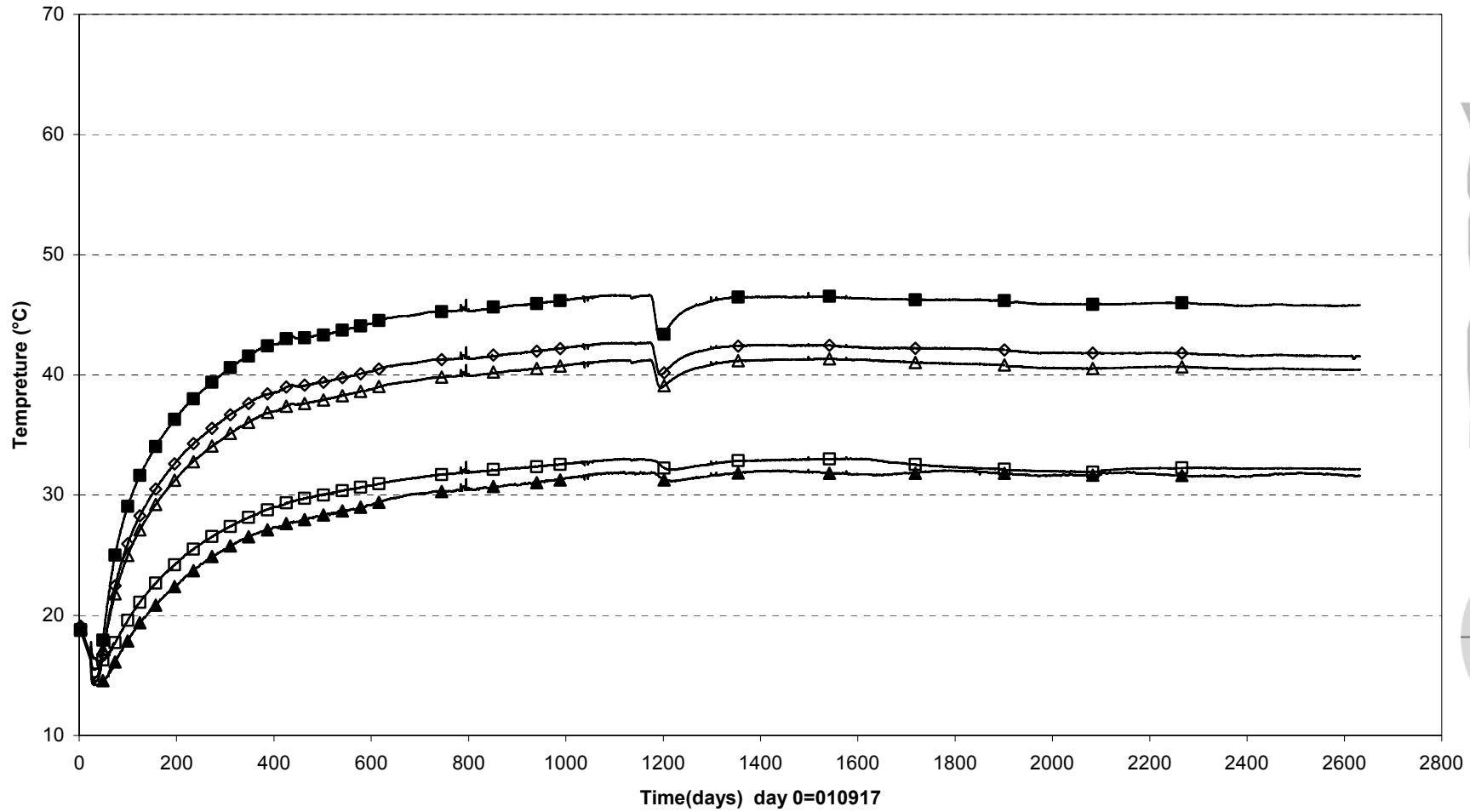

□ TROA3050 (7.671\360°\2.017)	△ TROA3040 (5.671\359°\2.025)	■ TROA3030(3.271\358°\2.034)
◇ TROA3020(0.871\358°\2.045)	▲ TROA3010(-1.778\357°\2.056)	

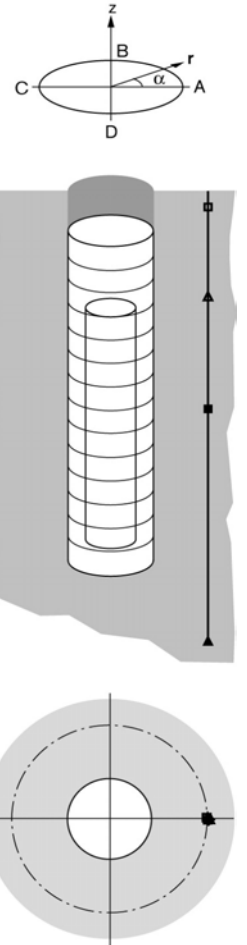

Prototype\Hole 4 (010917-081201)
Canister power

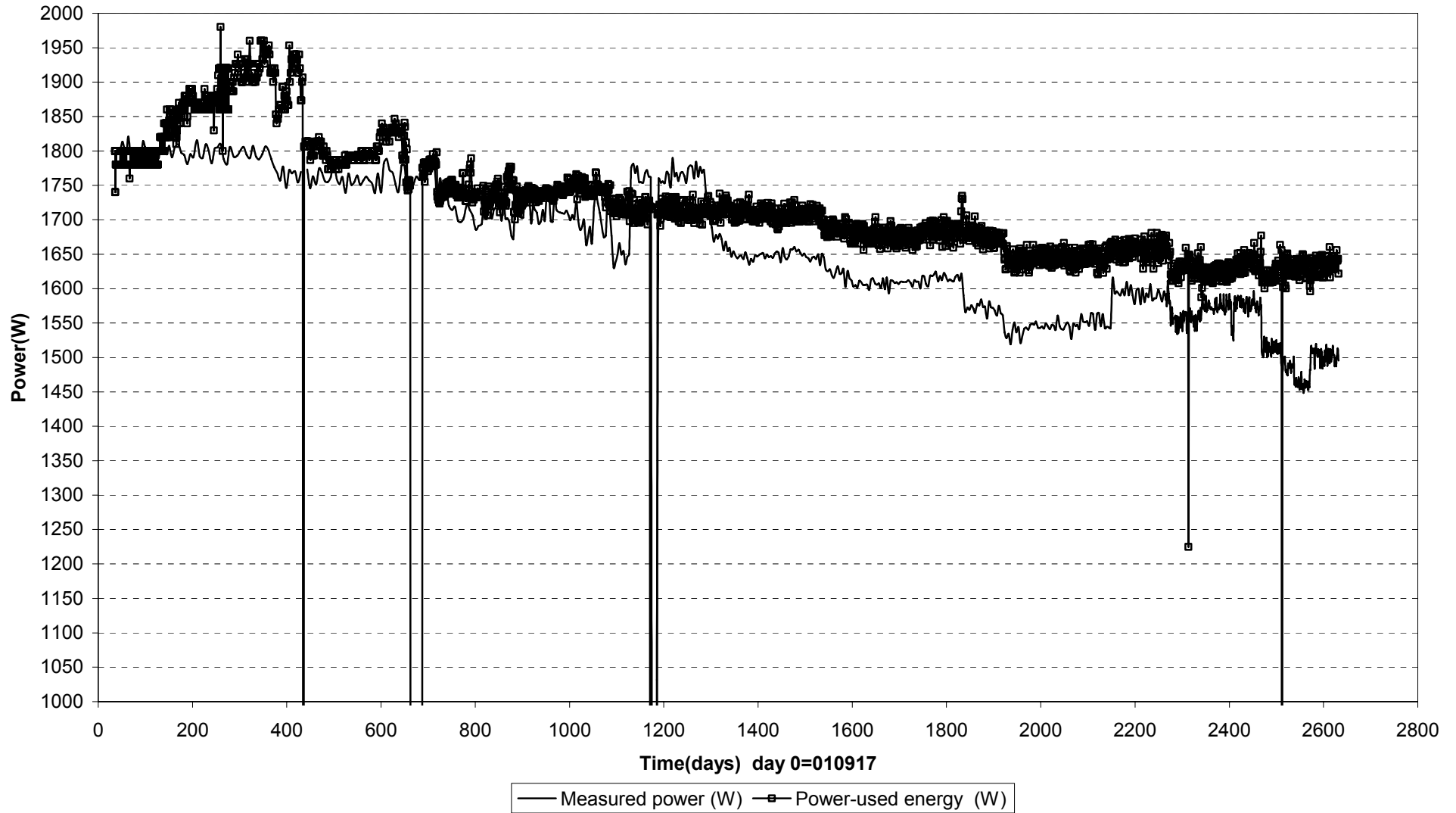

Prototype\ Hole 4 \Canister (010917-070601)
 Max. temperature on the canister surface - Optical fiber cables

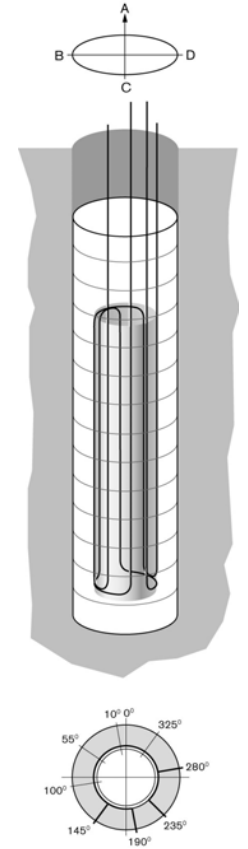
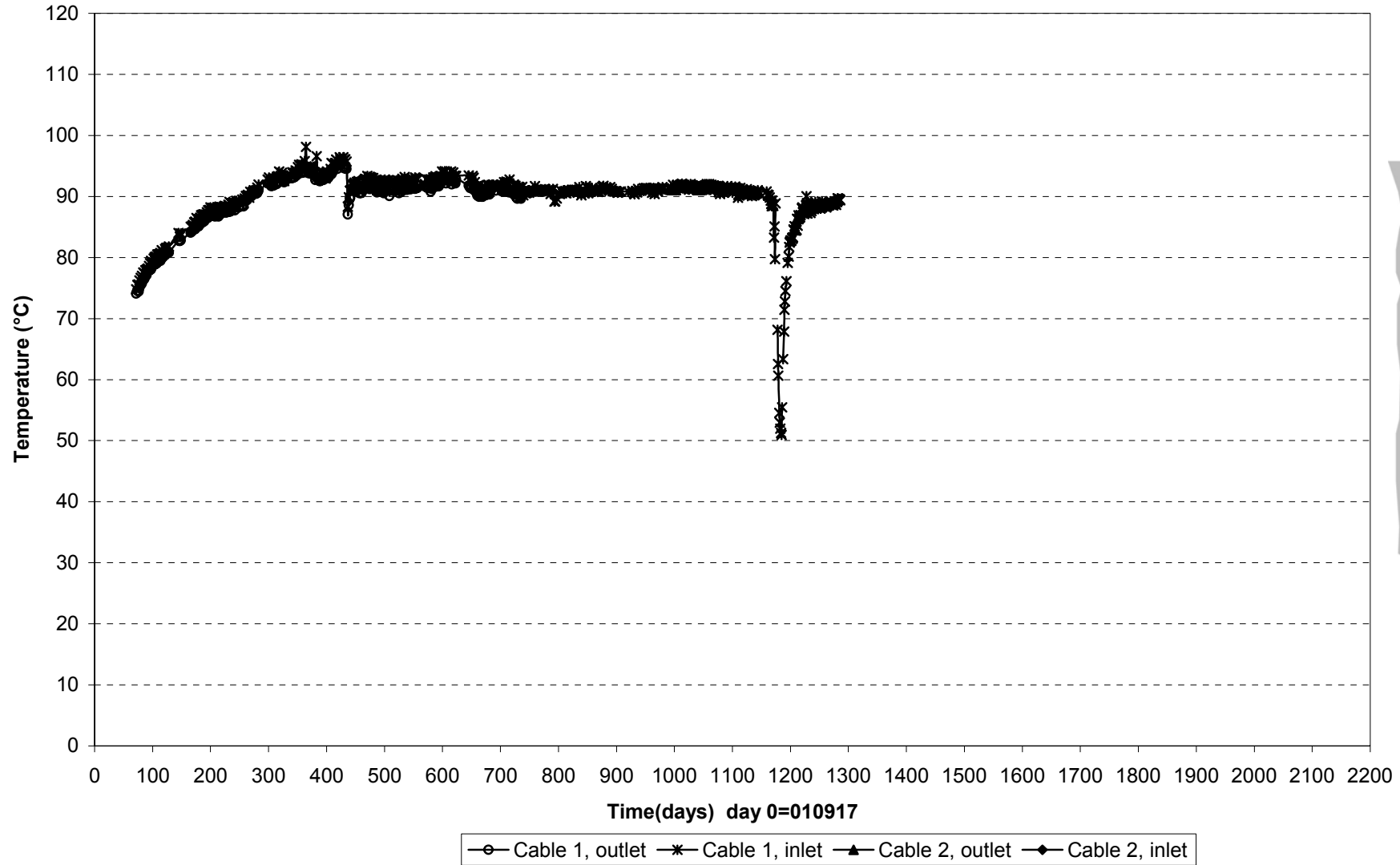

Prototype\ Hole 4\Canister (041130)
Temperature profile on the canister surface - Optical fiber cables

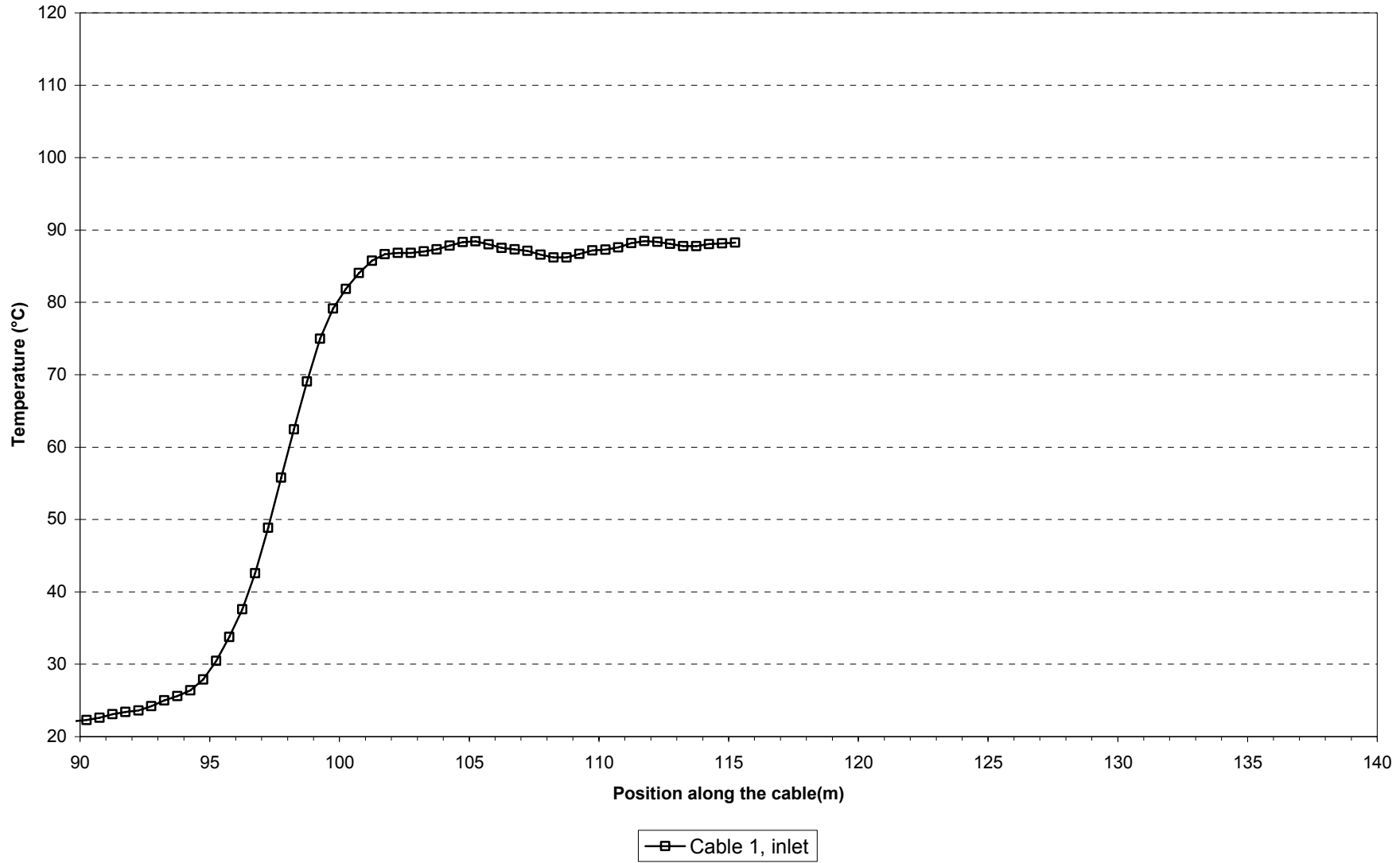

Appendix 4

Backfill in section 1

Prototype\Backfill\Section 1 (010917-081201)
 Total pressure - Geokon

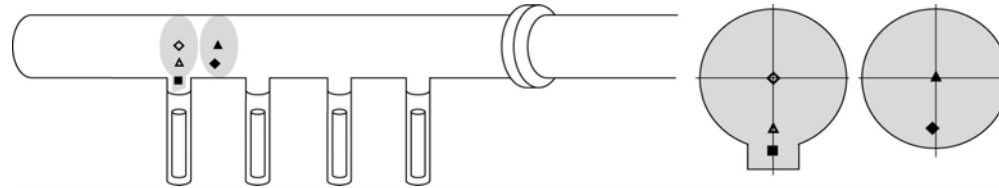
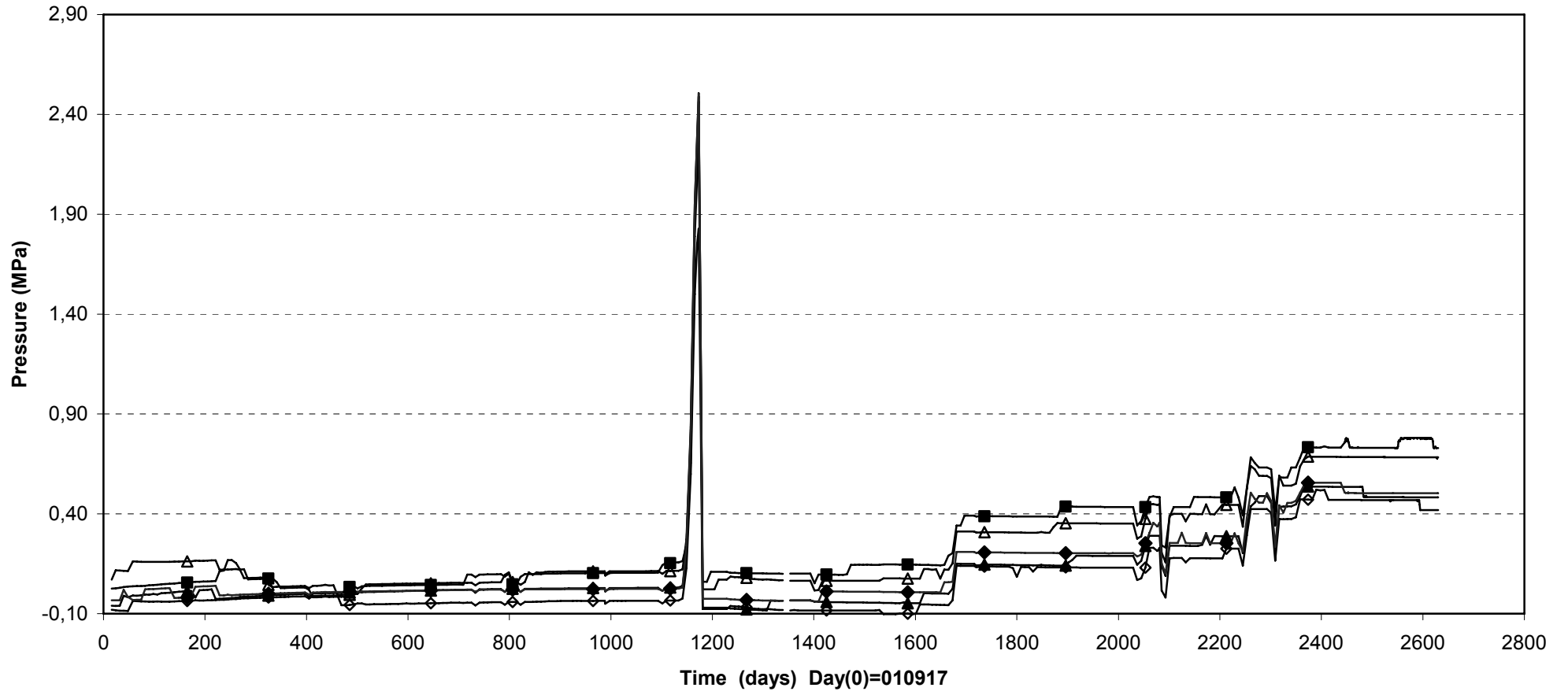

- ◇ PBA10002(E1\0\0\3587)
- △ PBA10003(E1\0 \-1,8\3587)
- PBA10004(E1\0 \-2,6\3587)
- ▲ PBA10008(F1-2\0\0\3584)
- ◆ PBA10009(F1-2\0-0.1\1,8\3584)

Prototype\Backfill\ Section 1 (010917-081201)
Total pressure - Geokon

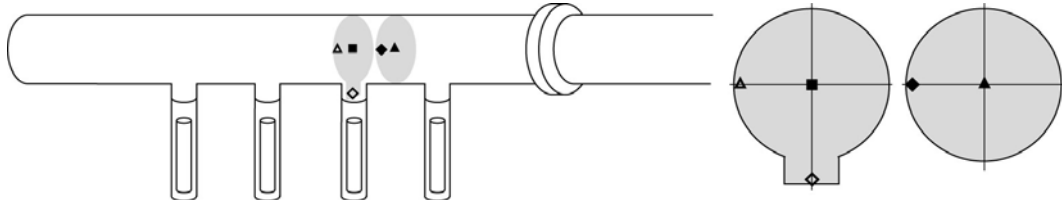
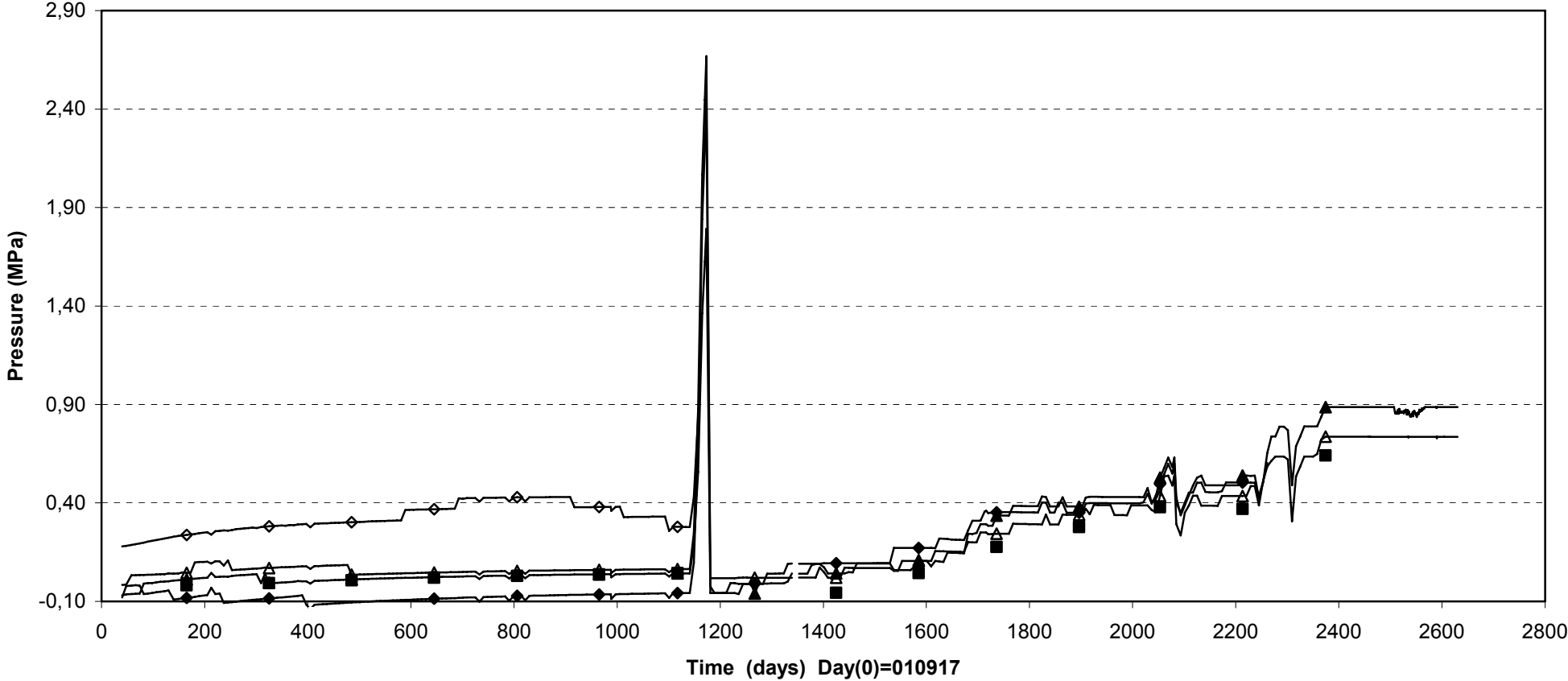

◇ PBA10015(E3\0\ -3.1\3575) △ PBA10016(E3\ -2.3\0\3575) ■ PBA10017(E3\0\0\3574) ▲ PBA10018(F3-4\0\0\3572) ◆ PBA10019(F3-4\0\ -2.3\3572)

Prototype\Backfill\Section 1 (041015-081201)
 Total pressure - Kulite

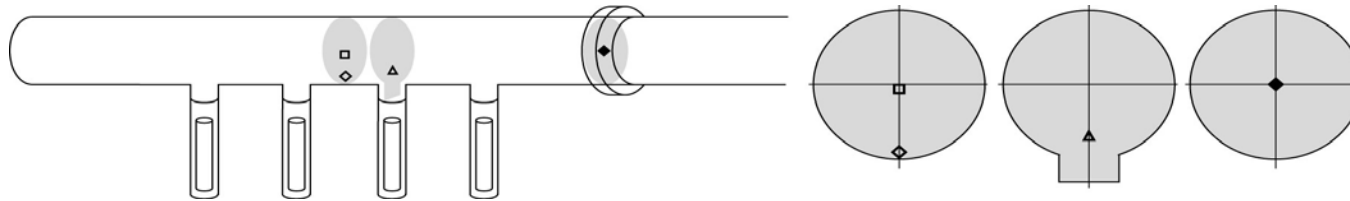
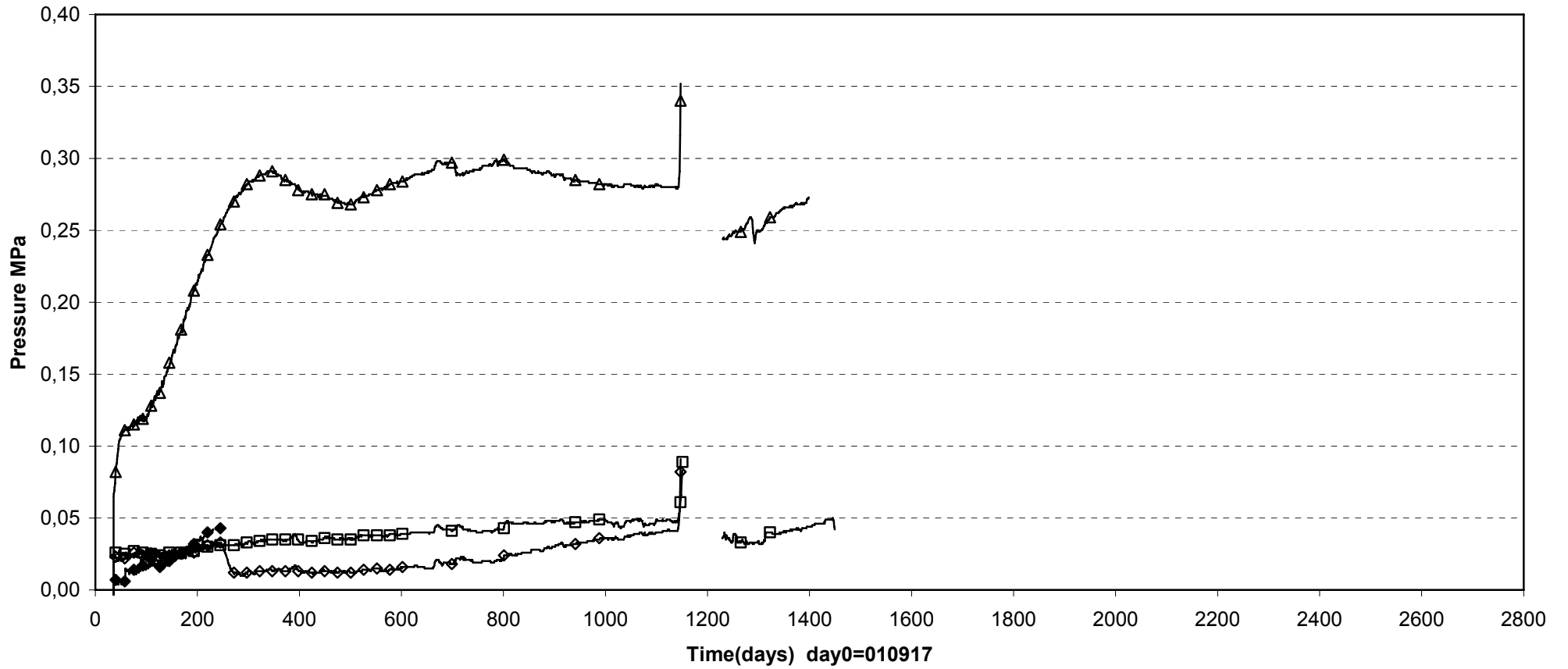

□ PBA10010(F1-2\0\ -0.2\3578) ◇ PBA10011(F1-2\0\ -2.3\3578) △ PBA10013(E3\0\ -1.82\3575) ◆ PBA10020(In front of plug\0\0\3561)

Prototype\Backfill\Section 1 (010917-081201)
Total pressure - Kulite

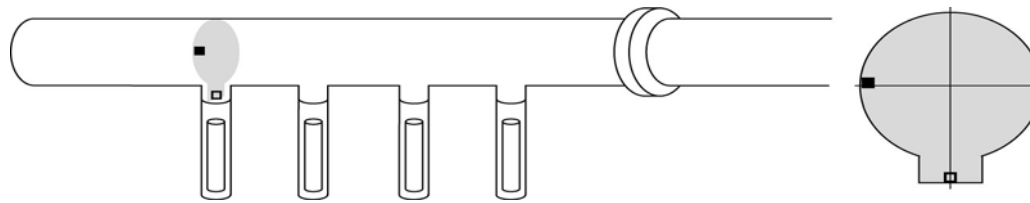
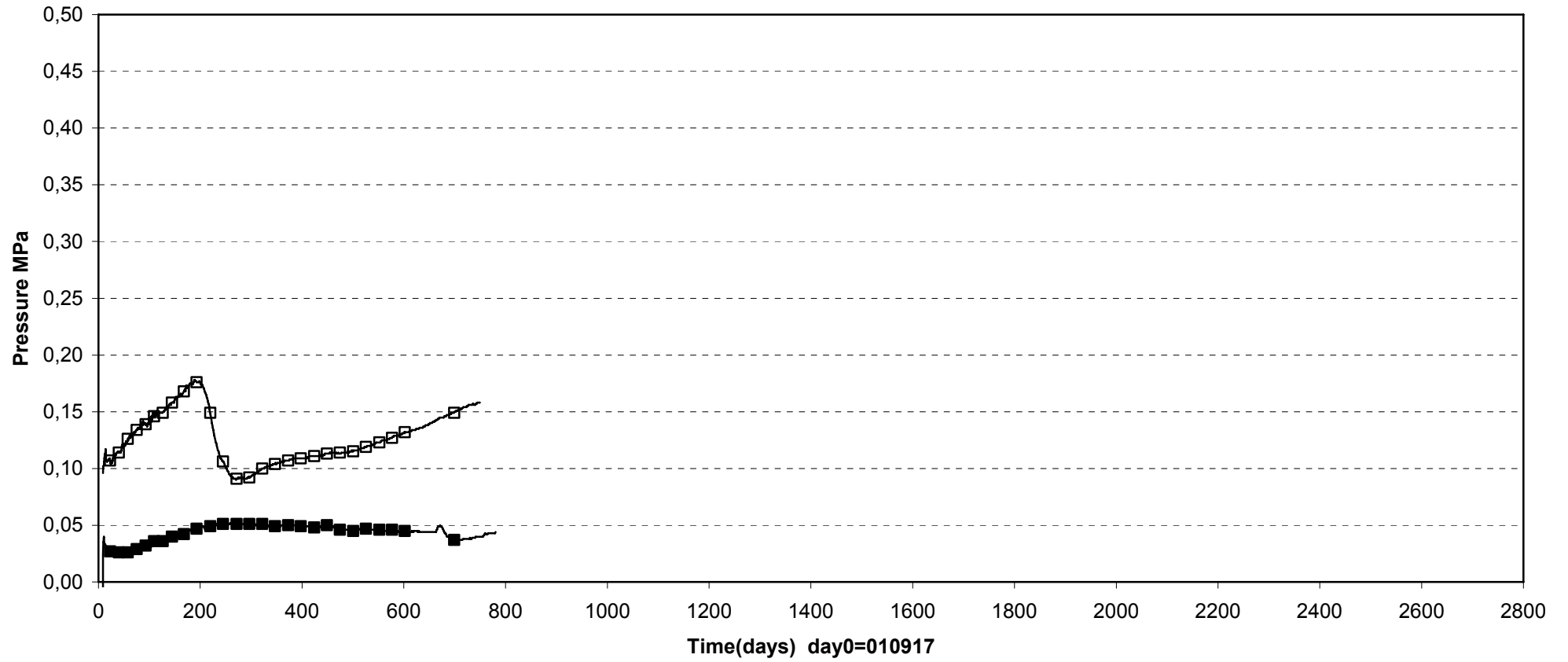

□ PBA10005(E1\0\ -3.1\3587) ■ PBA10006(E1\ -2.3\0.1\3587)

Prototype\Backfill \ Inner part (010917-081201)
Suction - Wescor

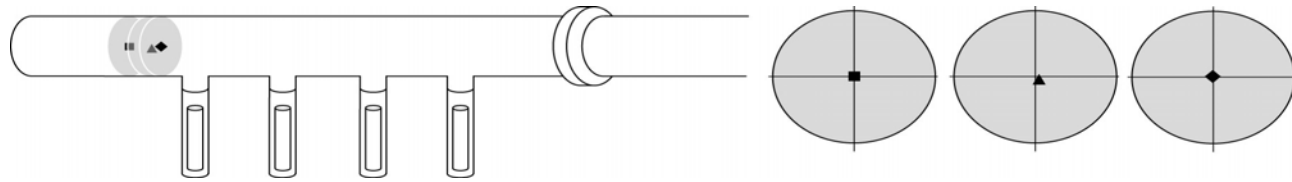
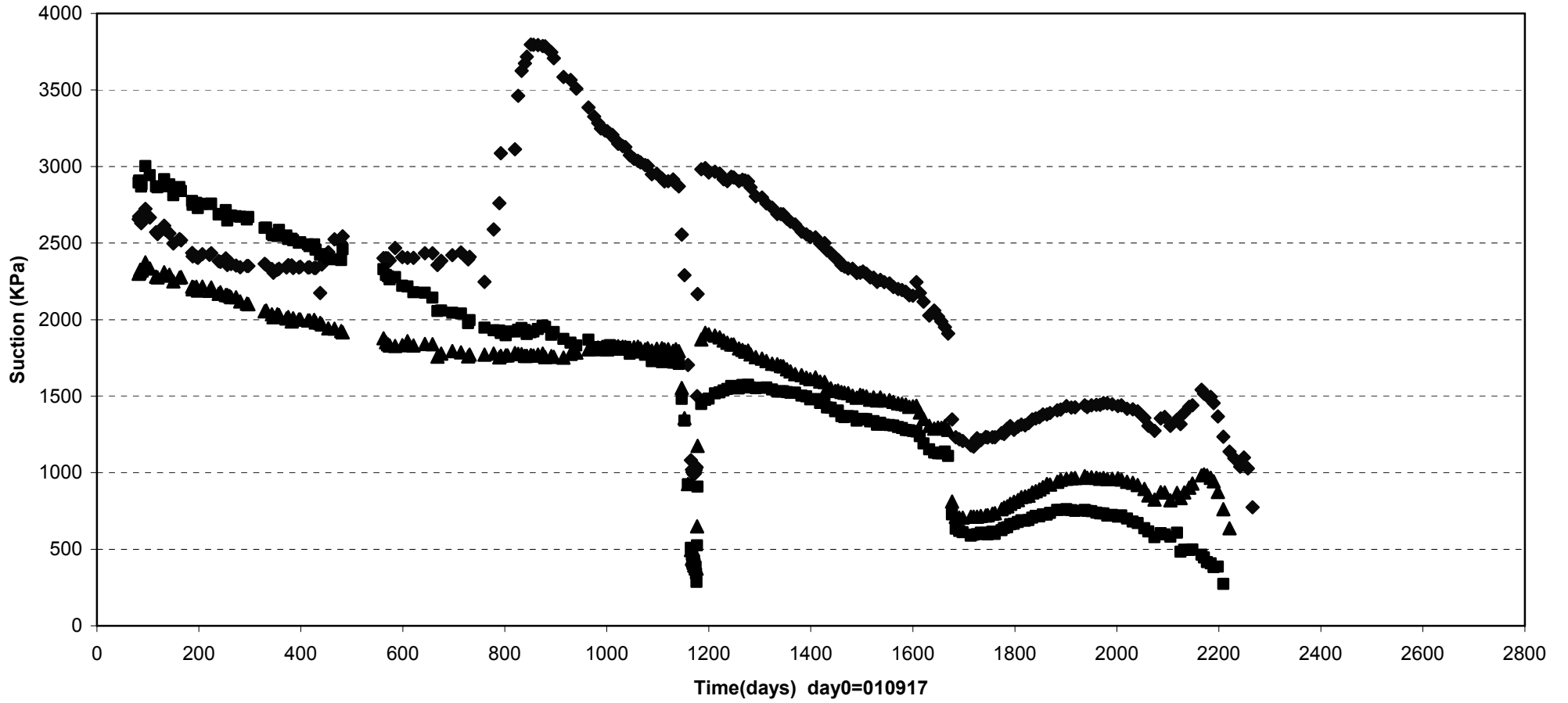

◆ WBA10001 (Inner part\0\0\3589) ■ WBA10002 (Inner part\0\0\3592) ▲ WBA10003 (Inner part\0.1\0.1\3590)

Prototype\Backfill\ Above dep.hole 1 (010917-081201)
Suction - Wescor

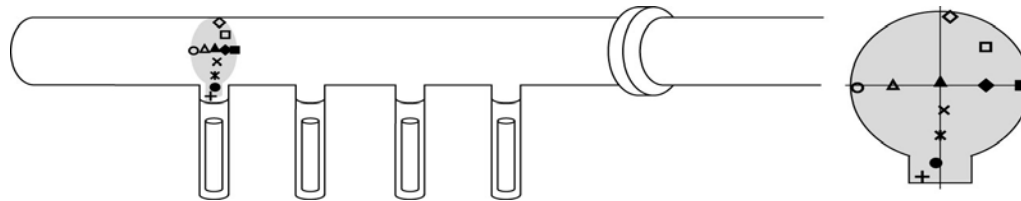
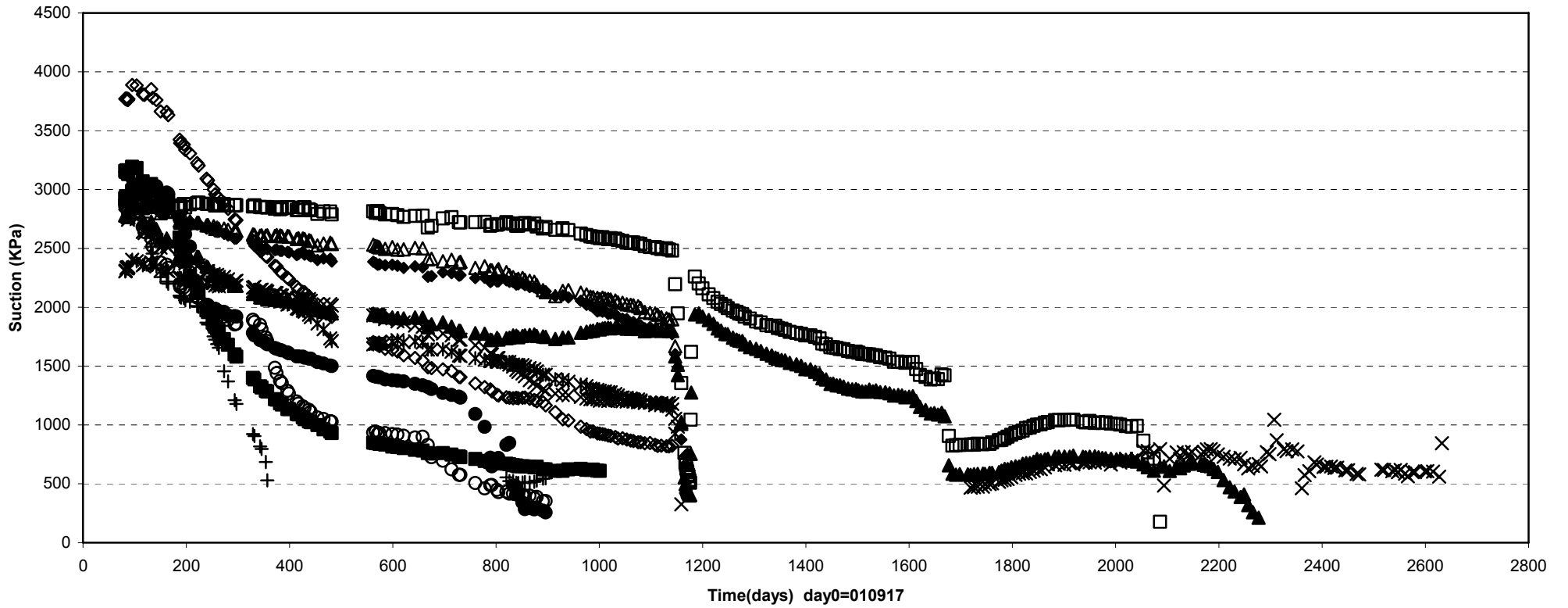

◇ WBA10004(E1\0.25\2.3\3587)	□ WBA10005(E1\0\1.25\3587)	▲ WBA10006(E1\0\0.1\3587)	× WBA10007(E1\0.1\0.8\3587)
✱ WBA10008(E1\0\1.7\3587)	● WBA10009(E1\0.1\2.6\3587)	+ WBA10010(E1\0.5\3.13\3587)	○ WBA10011(E1\2.3\0.1\3587)
△ WBA10012(E1\1.3\0\3587)	◆ WBA10013(E1\1.3\0\3587)	■ WBA10014(E1\2.3\0\3587)	

Prototype\Backfill \ Between dep.hole 1 and hole 2 (010917-081201)
 Suction - Wescor

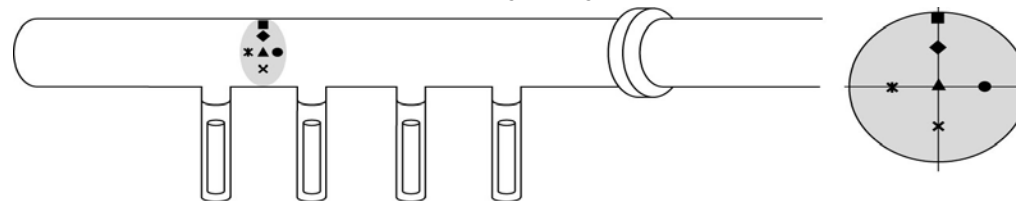
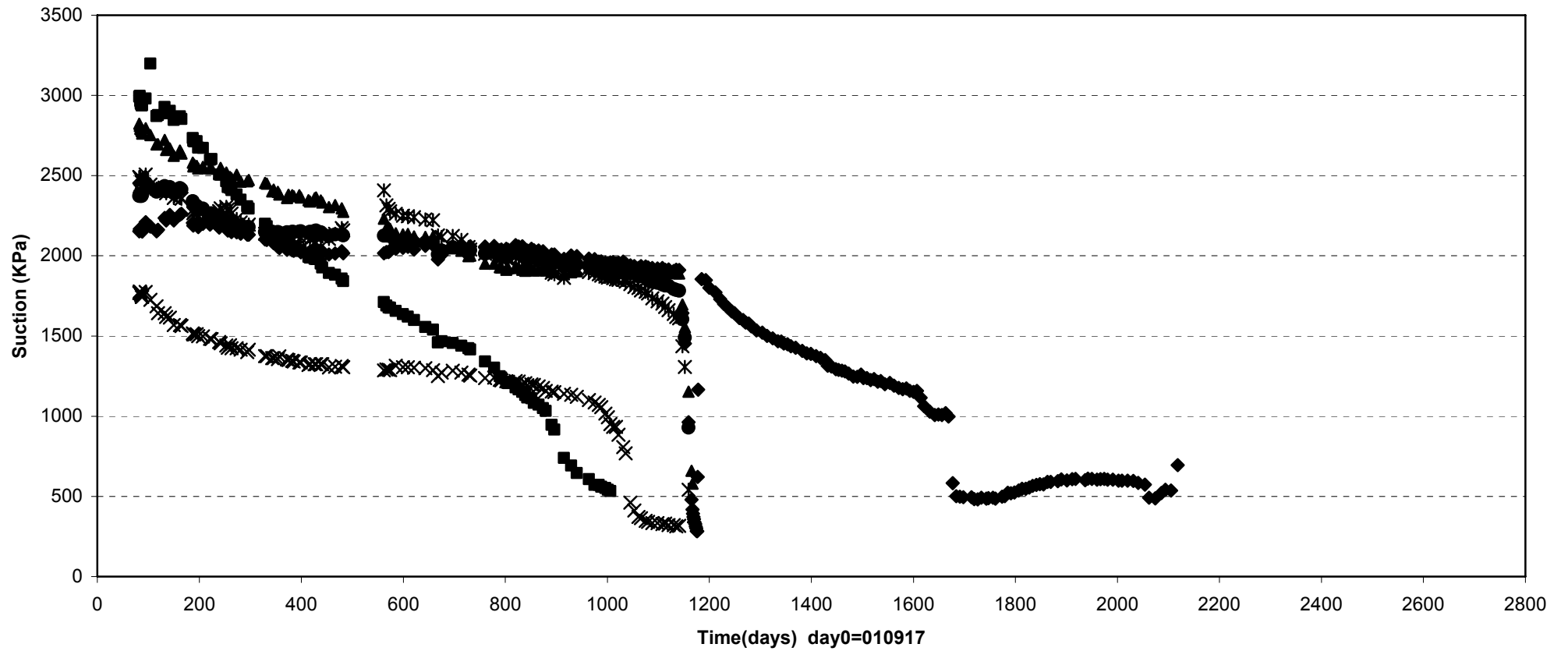

- ◆ WBA10015(F1-2\0\1.3\3584) ■ WBA10016(F1-2\0\2.3\3584) ▲ WBA10017(F1-2\0\0\3584) × WBA10018(F1-2\0\1.3\3584)
- ✱ WBA10019(F1-2\1.3\0\3584) ● WBA10020(F1-2\1.3\0\3584)

Prototype\Backfill \ Between dep.hole 2 and hole 3 (010917-081201)
 Suction - Wescor

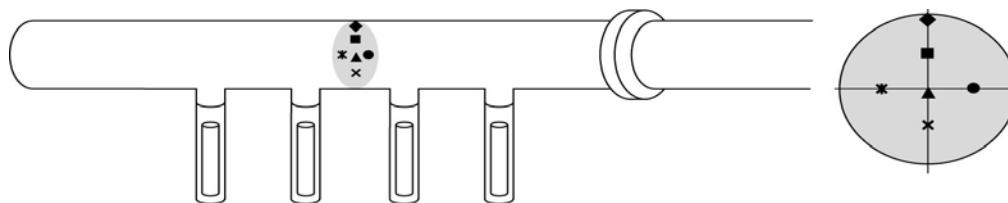
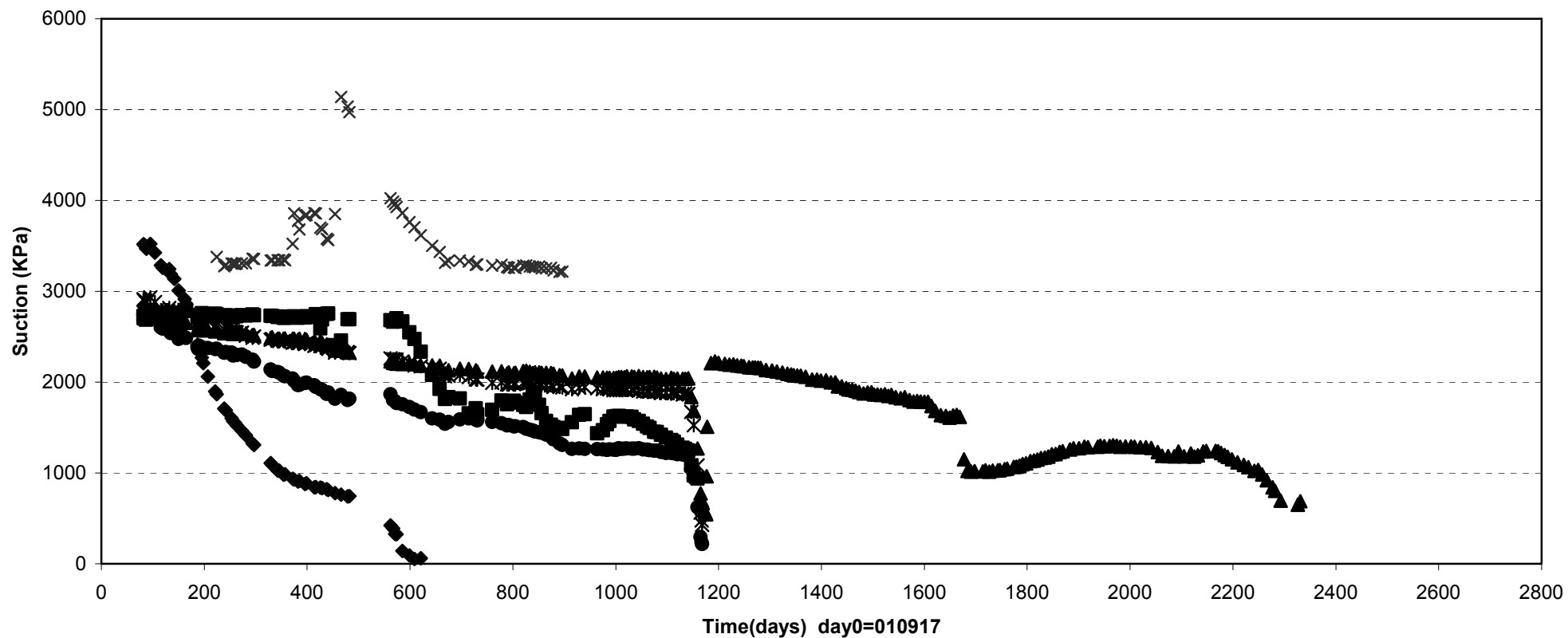

- ◆ WBA10021(F2-3\0\2.3\3578) ■ WBA10022(F2-3\0\1.2\3578) ▲ WBA10023(F2-3\0\0.2\3578) ✖ WBA10025(F2-3\1.3\0\3578)
- WBA10026(F2-3\1.3\0\3578) × WBA10024(F2-3\0\1.2\3578)

Prototype\Backfill\ Above dep.hole 3 (010917-081201)
Suction - Wescor

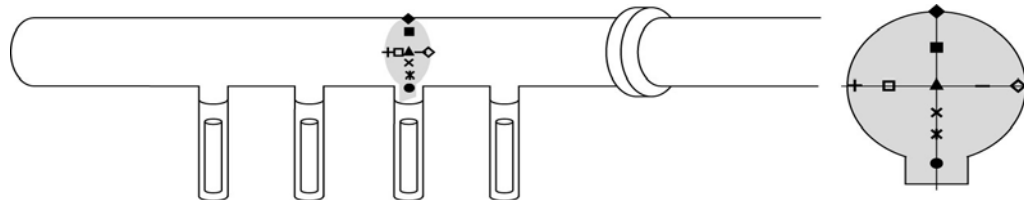
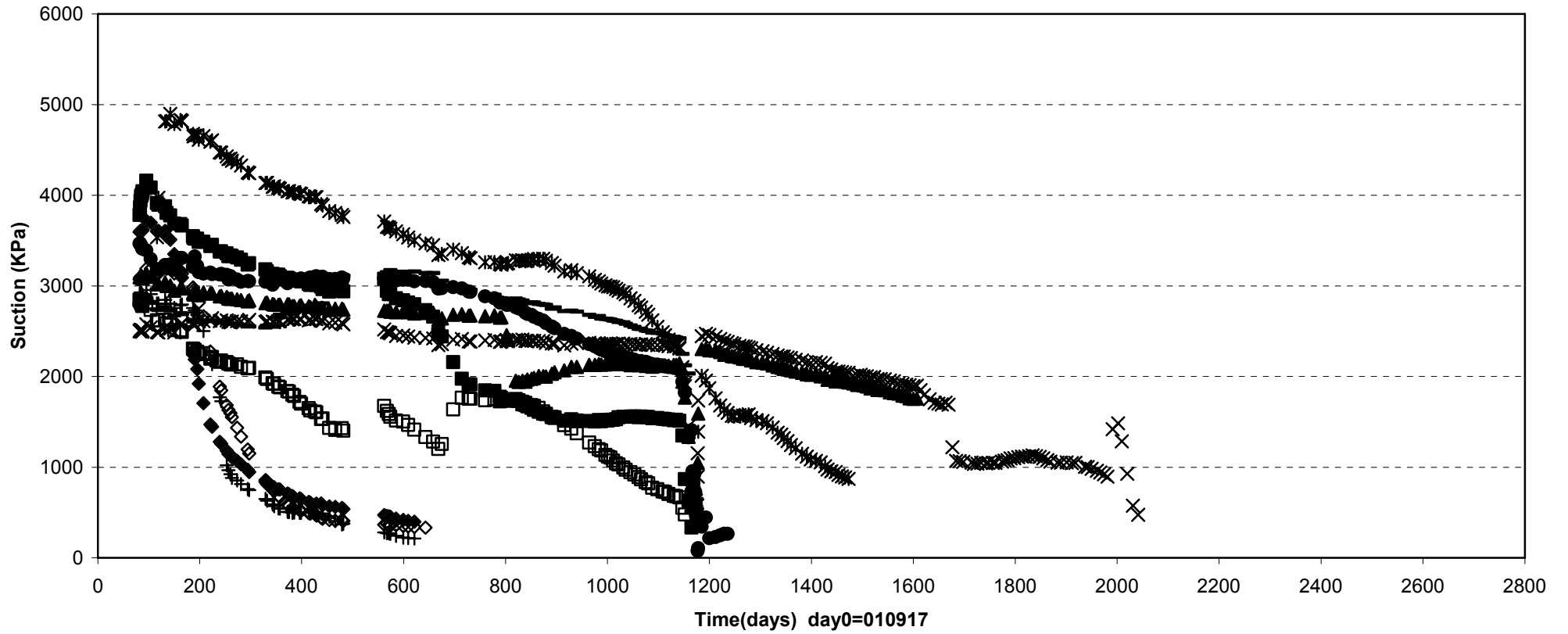

- | | | | | |
|-------------------------------|---------------------------|---------------------------|-----------------------------|---------------------------|
| ◆ WBA10027(E3\0\2.5\3574) | ■ WBA10028(E3\0\1.3\3575) | ▲ WBA10029(E3\0\0\3575) | × WBA10030(E3\0\0-0.9\3575) | ✱ WBA10031(E3\0\1.6\3575) |
| ● WBA10032(E3\0-0.3\2.6\3575) | + WBA10034(E3\2.3\0\3575) | □ WBA10035(E3\1.3\0\3575) | — WBA10036(E3\1.3\0\3575) | ◇ WBA10037(E3\2.3\0\3575) |

Prototype\Backfill \ Between dep.hole 3 and hole 4 (010917-081201)
 Suction - Wescor

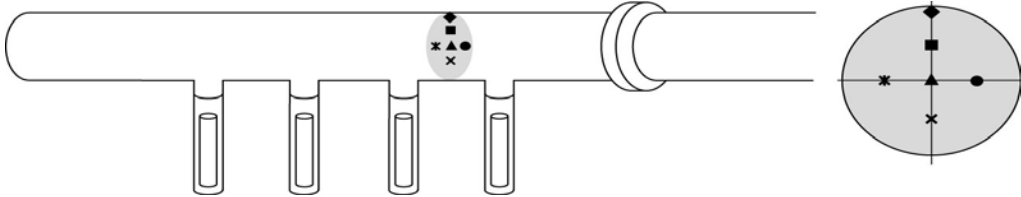
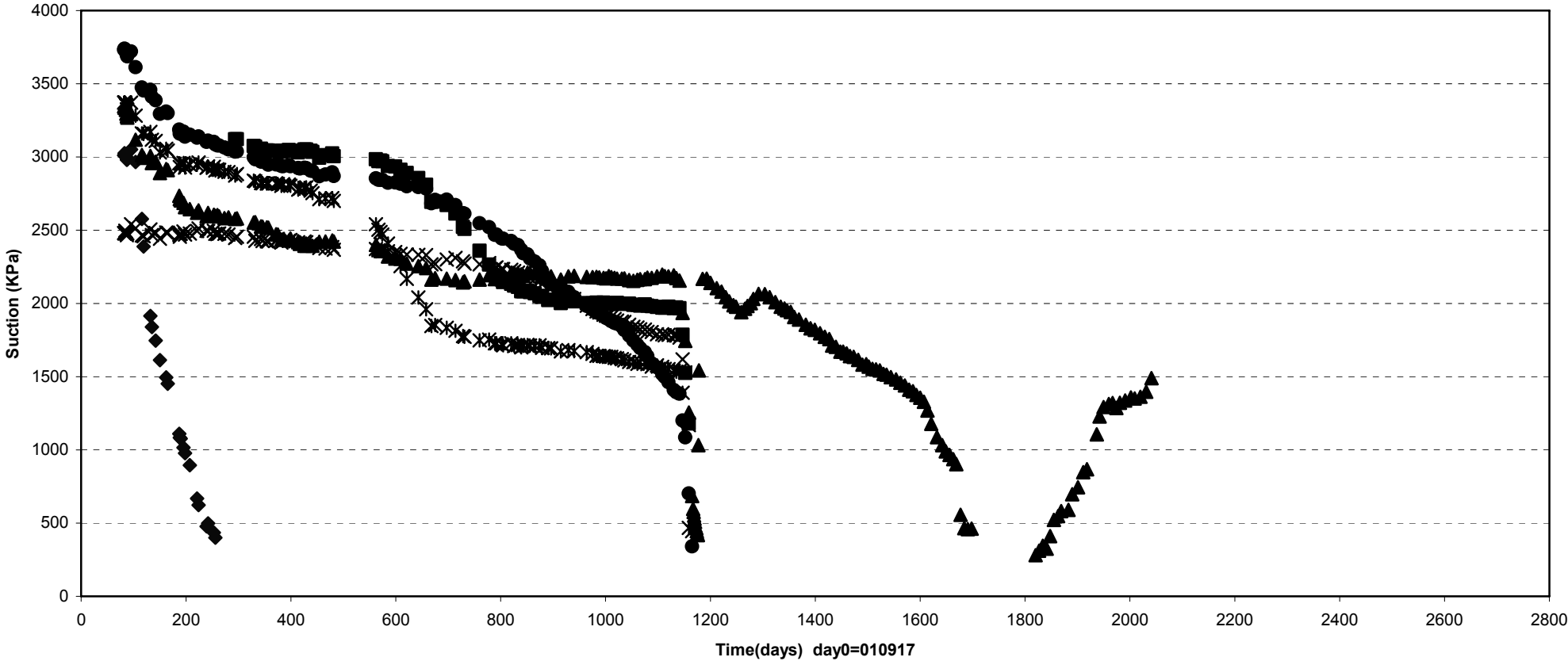

- ◆ WBA10038(F3- 4\0\2.3\3572)
- WBA10039(F3- 4\0\1.2\3572)
- ▲ WBA10040(F3- 4\0\0\3572)
- × WBA10041(F3- 4\0\1.3\3572)
- ✱ WBA10042(F3- 4\1.3\0\3572)
- WBA10043(F3- 4\1.3\0\3572)

Prototype\Backfill \ In front of plug (010917-081201)
 Suction - Wescor

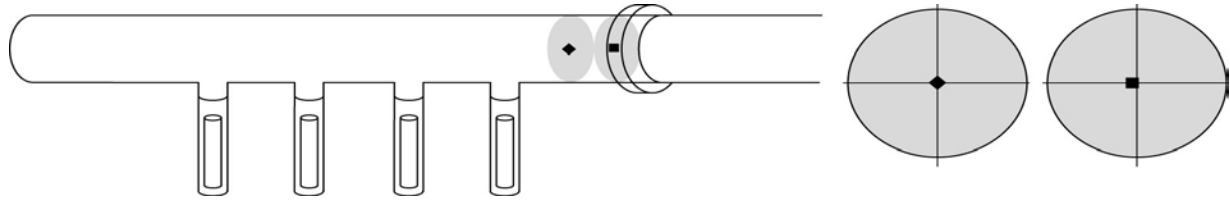
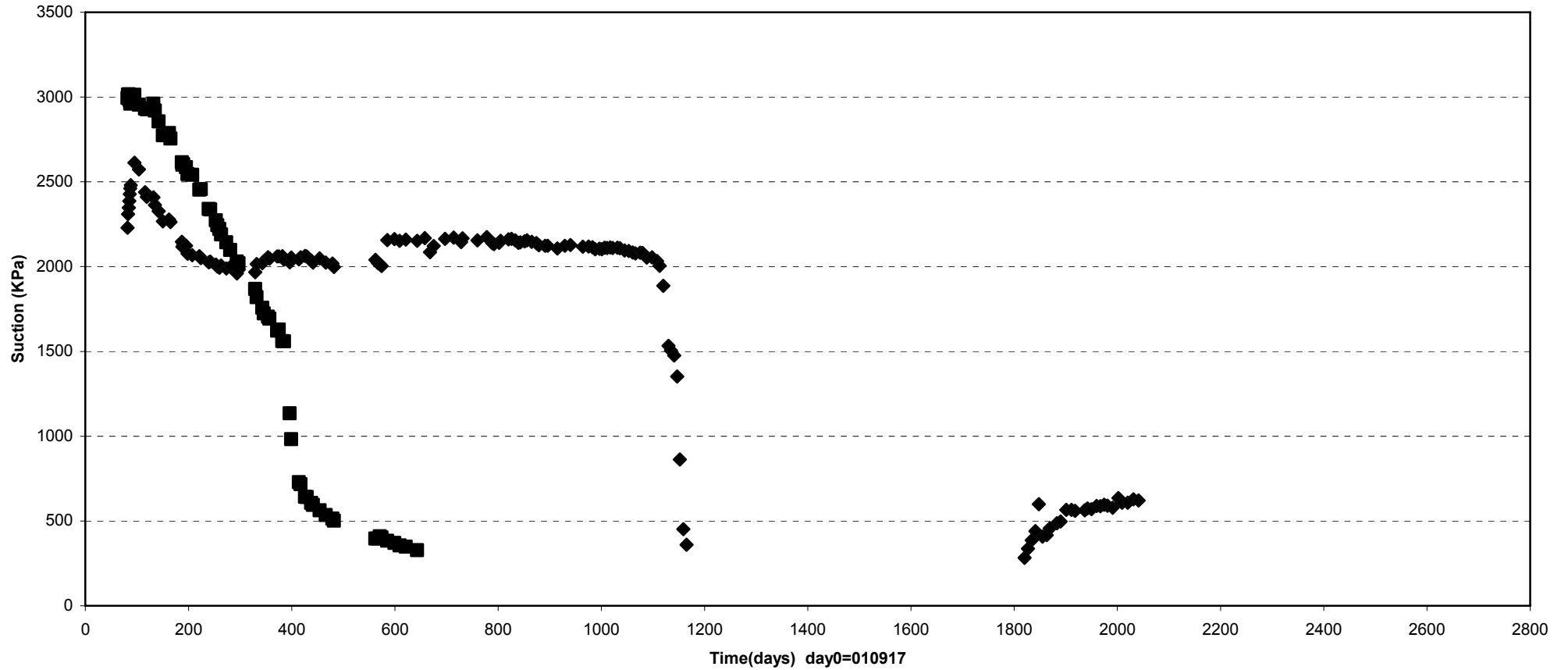

◆ WBA10044(In front of plug\0\0\3565) ■ WBA10045(In front of plug\0.1\0\3562)

Prototype\Backfill\Section 1 (010917-081201)
 Pore pressure - Geokon

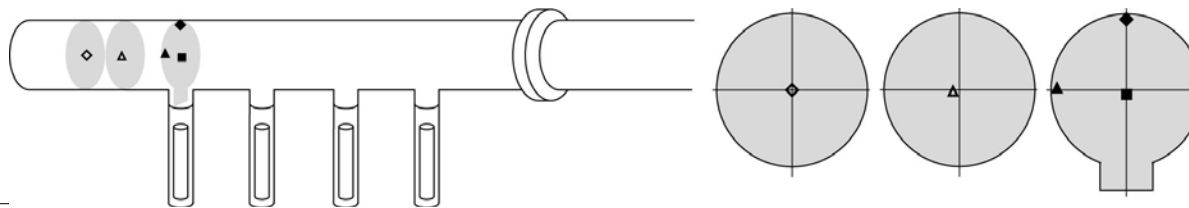
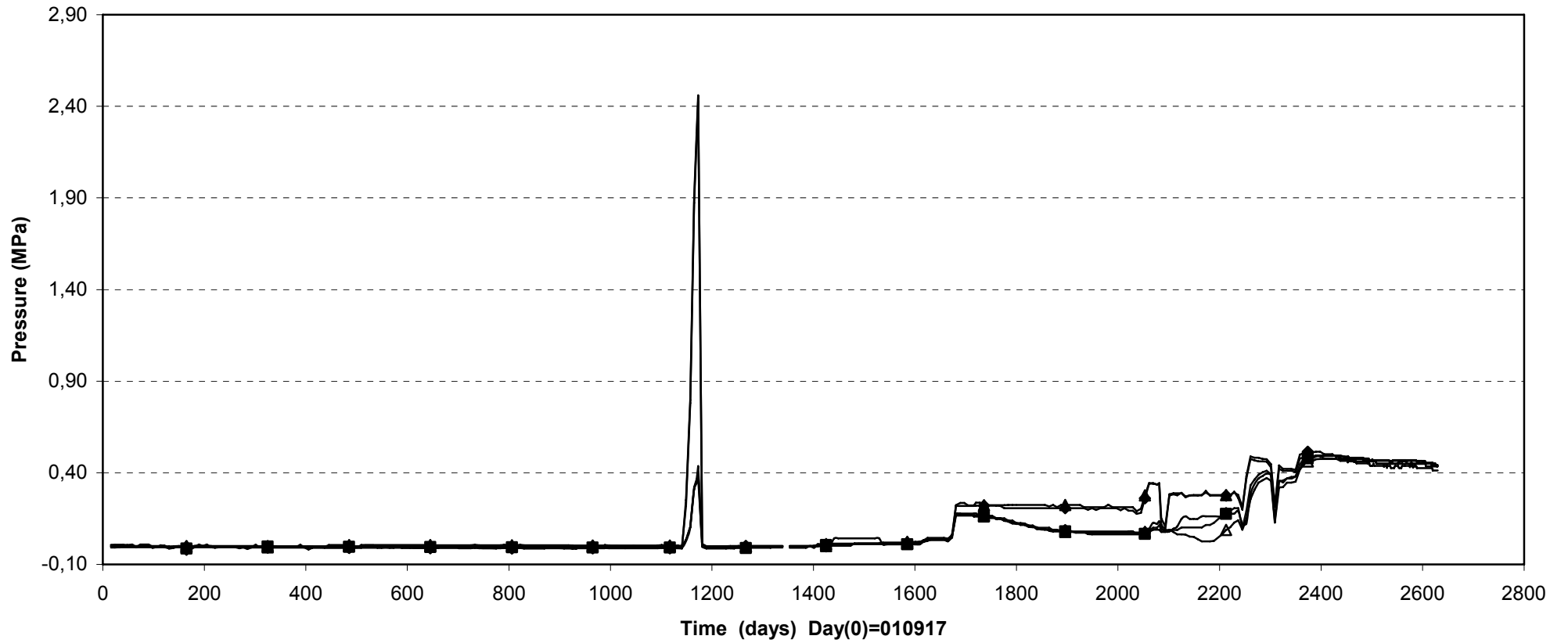

◇ UBA10002(Inner part\0\0\3592) △ UBA10003(Inner part\ -0.2\ -0.1\3590) ■ UBA10004(E1\0\0\3587) ▲ UBA10008(E1\ -2.3\0\3587) ◆ UBA10009(E1\0\2.3\3587)

Prototype\Backfill \ Section 1 (010917-081201)
 Pore pressure - Geokon

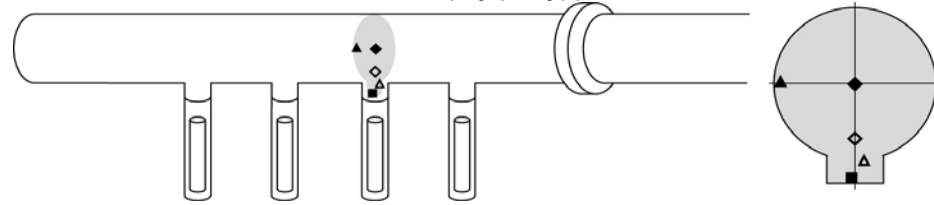
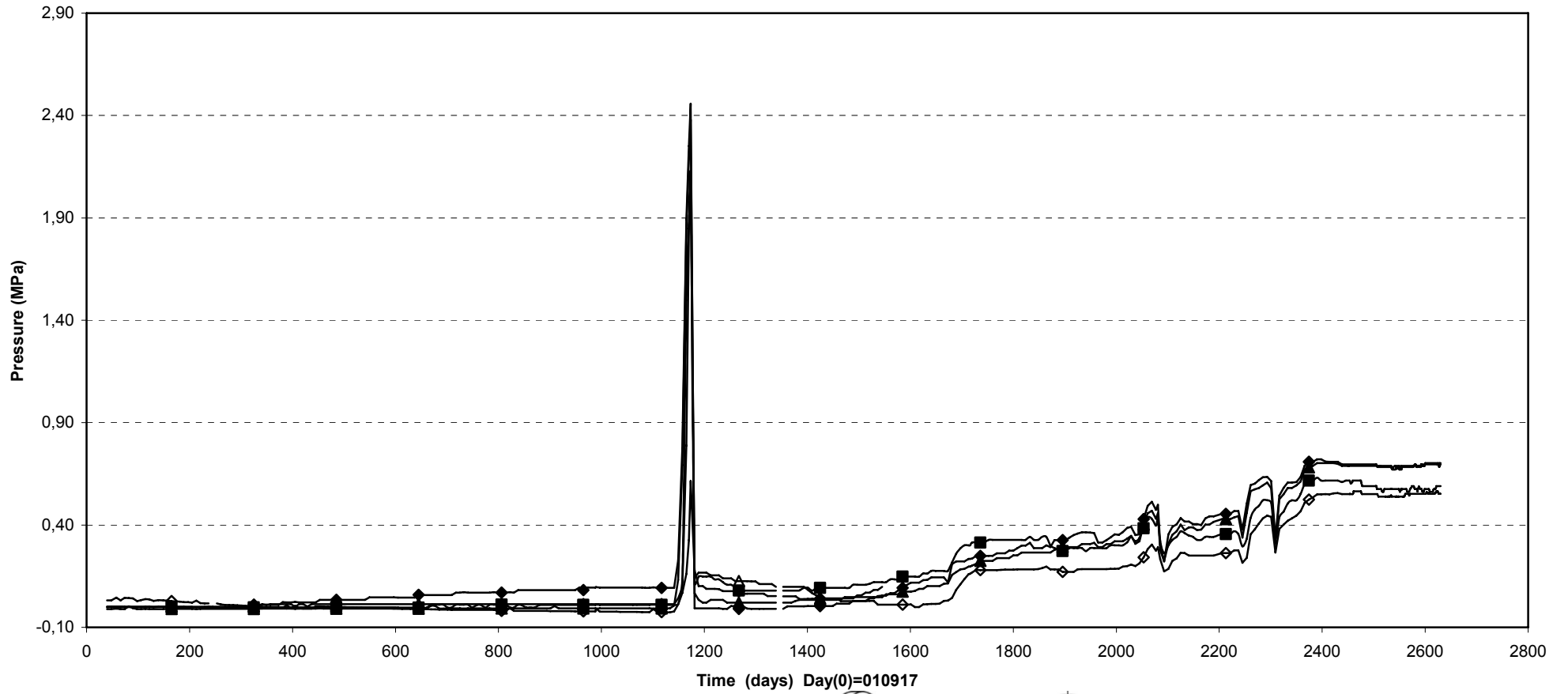

◇ UBA10015(E3\0\ -1.82\3575) △ UBA10016(E3\0.25\ -2.6\3575) ■ UBA10017(E3\ -0.1\ -3.1\3575) ▲ UBA10018(E3\ -2.3\0\3575) ◆ UBA10019(E3\0\0\3574)

Prototype\Backfill\ Section 1 (010917-081201)
Pore pressure - Kulite

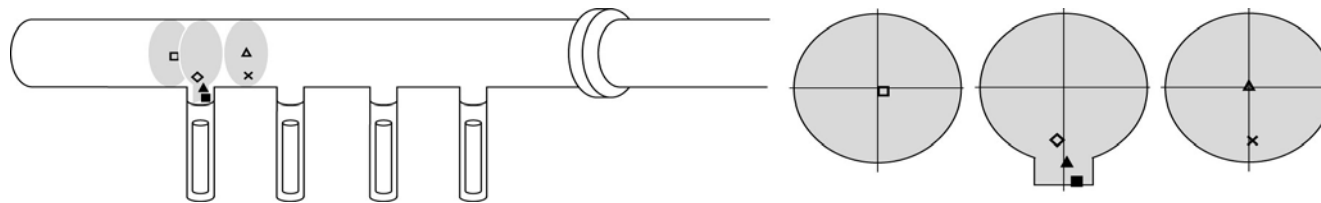
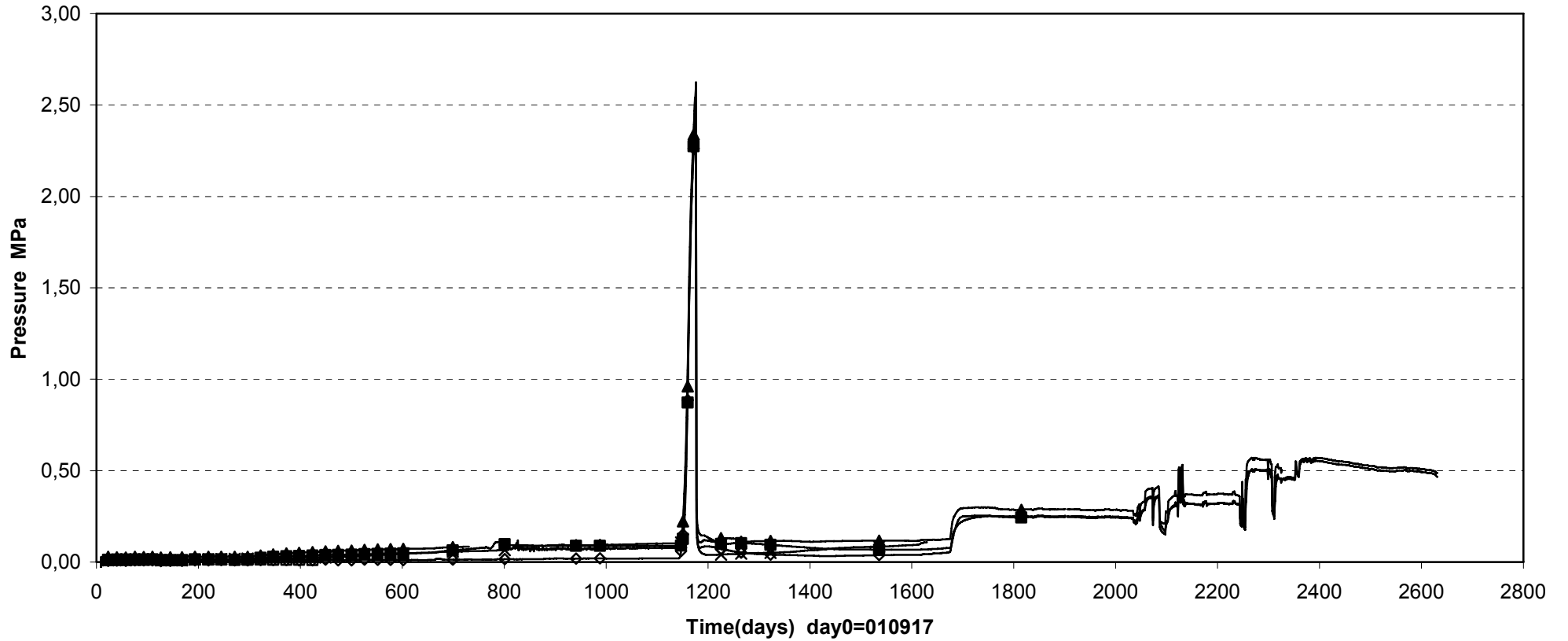

□ UBA10001 (Inner part\0.2\0.1\3589)	◇ UBA10005 (E1\0.2\1.8\3587)	▲ UBA10006 (E1\0.1\2.6\3587)
■ UBA10007 (E1\0.4\3.2\3587)	△ UBA10010 (F1-2\0\3584)	× UBA10011 (F1-2\0.1\1.2\3584)

Prototype\Backfill \Section 1 (041015-081201)
Pore pressure - Kulite

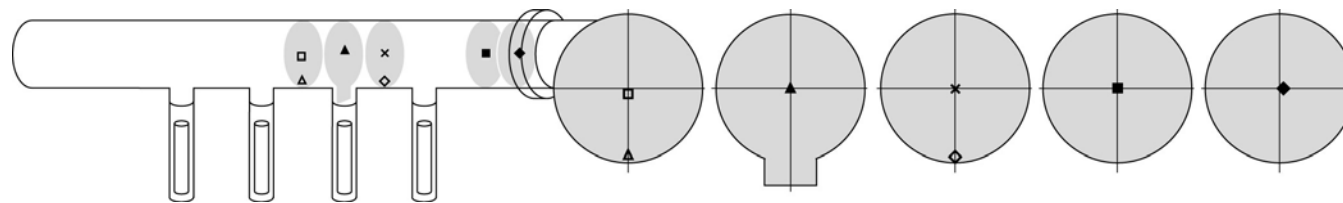
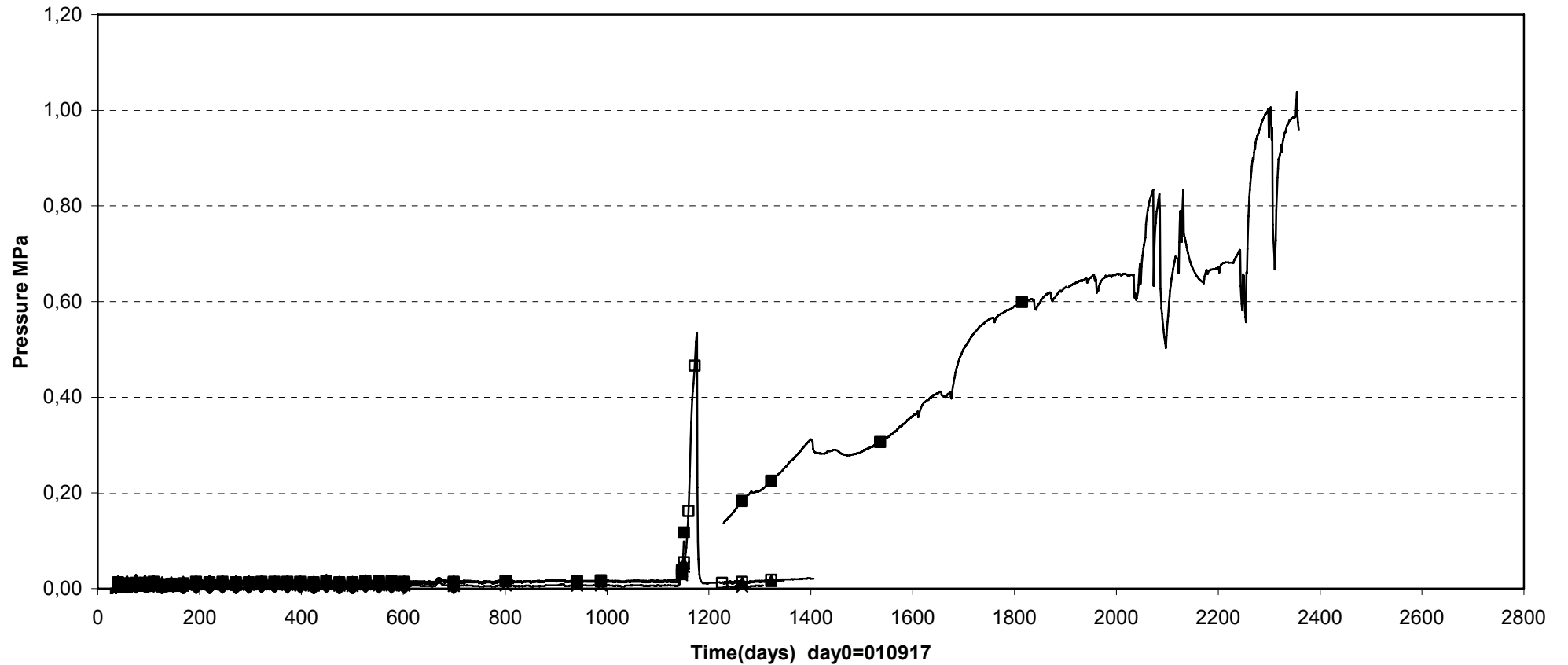

- | | | | |
|-----------------------------|---------------------------------------|---|---------------------------|
| □ UBA10012(F2-3\0\0.2\3578) | △ UBA10013(F2-3\0\2.3\3578) | ▲ UBA10014(E3\0\0\3575) | × UBA10020(F3-4\0\0\3572) |
| ◇ UBA10021(F3-4\0\2.3\3572) | ■ UBA10022(In front of plug\0\0\3565) | ◆ UBA10023(In front of plug\0.1\0\3561) | |

Prototype\ Backfill \ Above dep.hole1 (010917-081201)
 Temperature - Pentronic

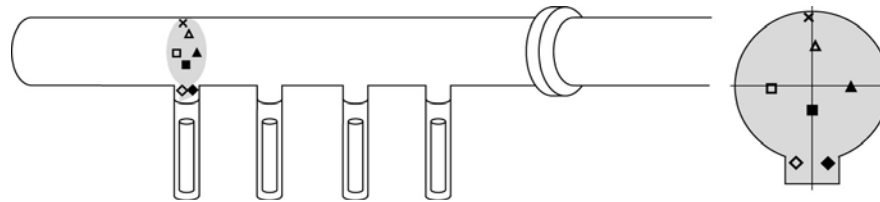
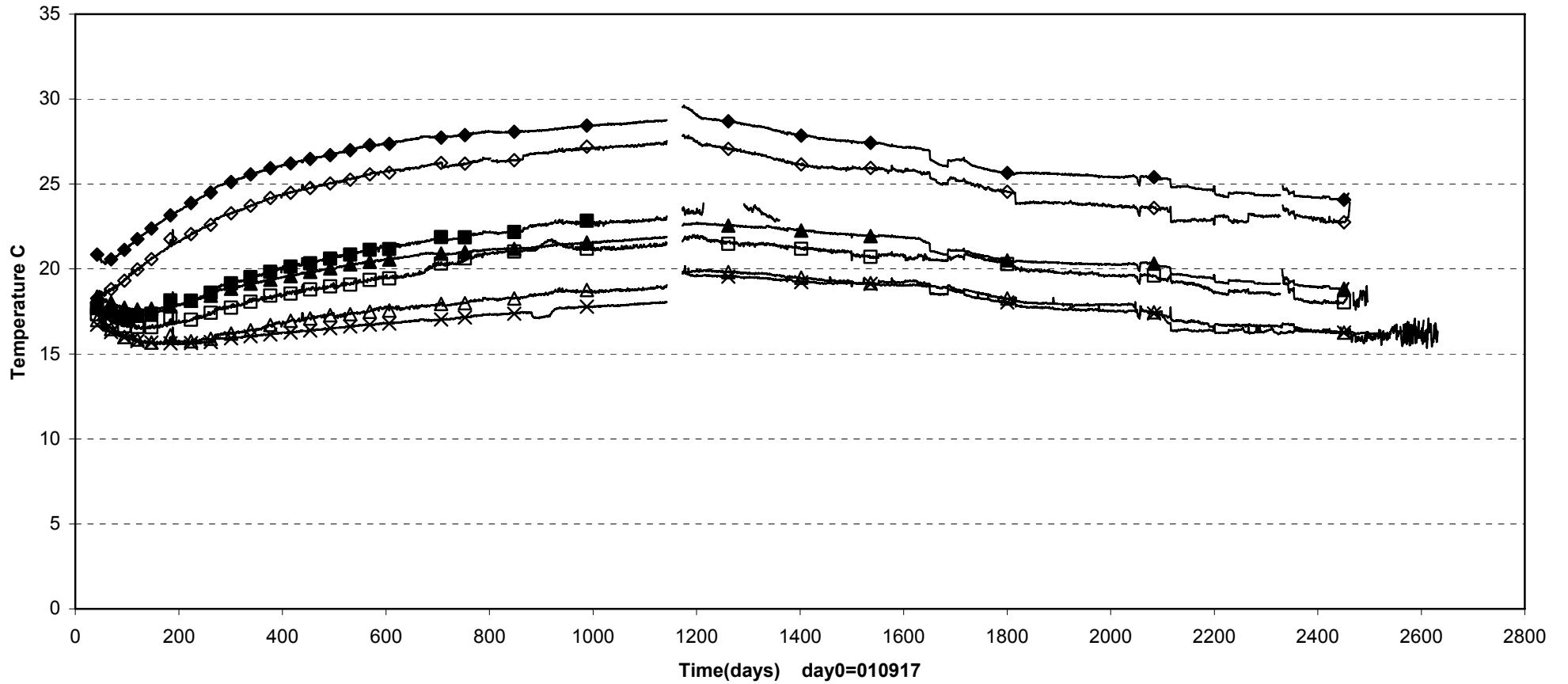

- | | | | |
|------------------------------|-----------------------------|------------------------------|-----------------------------|
| □ TBA10001(E1\1.25\0.1\3587) | △ TBA10002(E1\0.1\1.3\3587) | ■ TBA10003(E1\0\0.8\3587) | ◇ TBA10004(E1\0.5\2.6\3587) |
| ◆ TBA10005(E1\0.5\2.6\3587) | × TBA10006(E1\0.1\2.3\3587) | ▲ TBA10007(E1\1.25\0.1\3587) | |

Prototype\ Backfill \ Between dep.hole 1-2 (010917-081201)
 Temperature - Pentronic

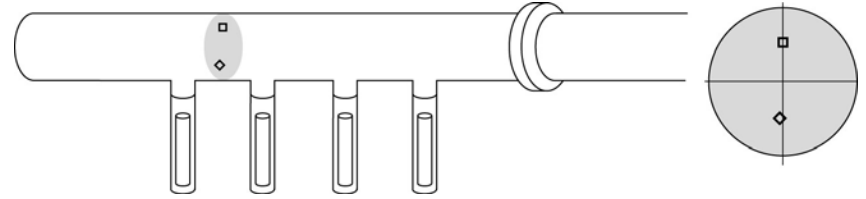
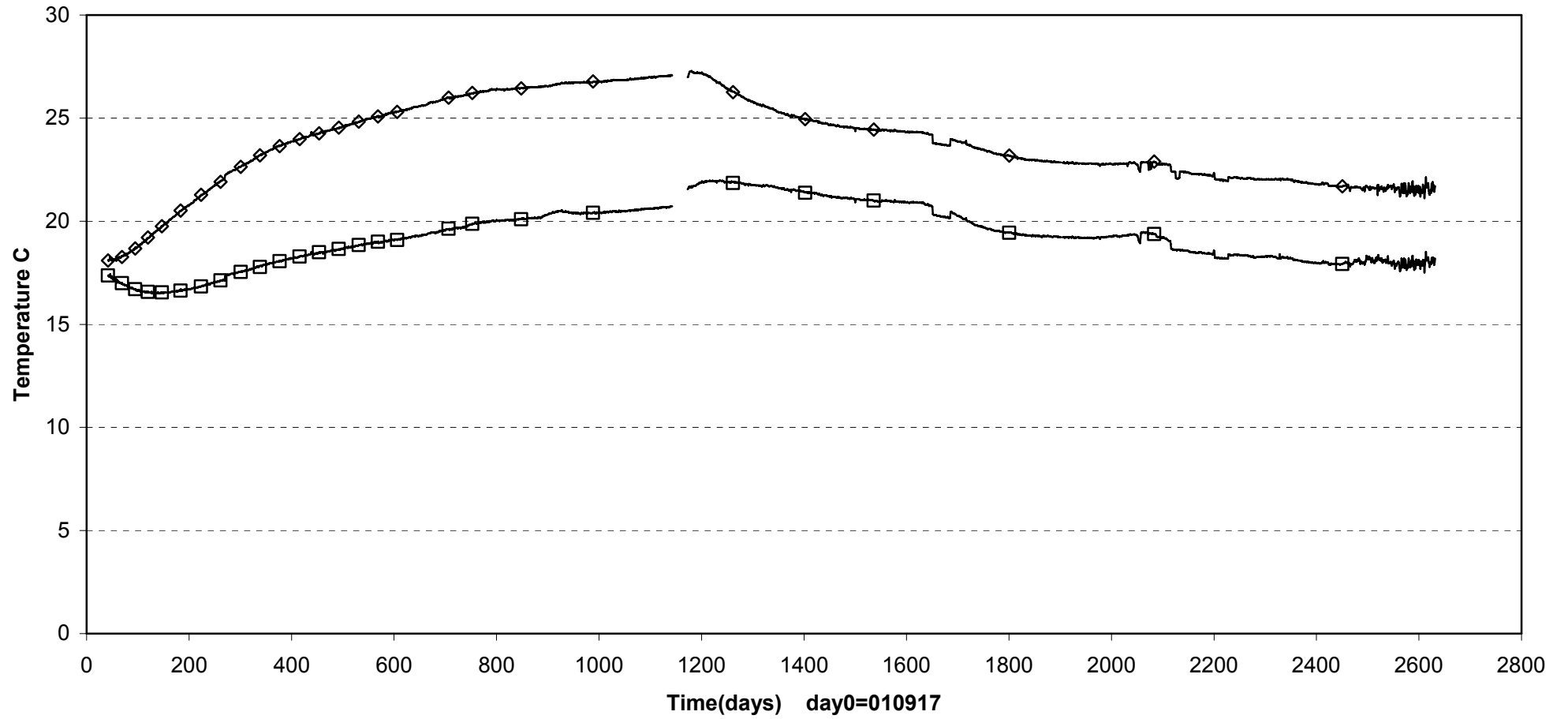

□ TBA10008(F1-2\0\1.25\3584) ◇ TBA10009(F1-2\0\1\1.3\3584)

Prototype\ Backfill \ Between dep.hole 2-3 (010917-081201)
 Temperature -Pentronic

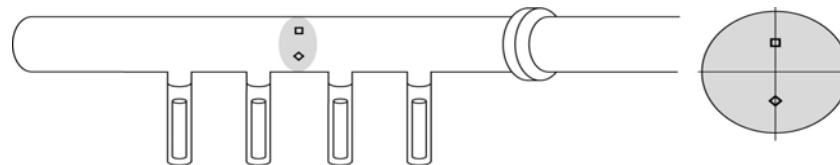
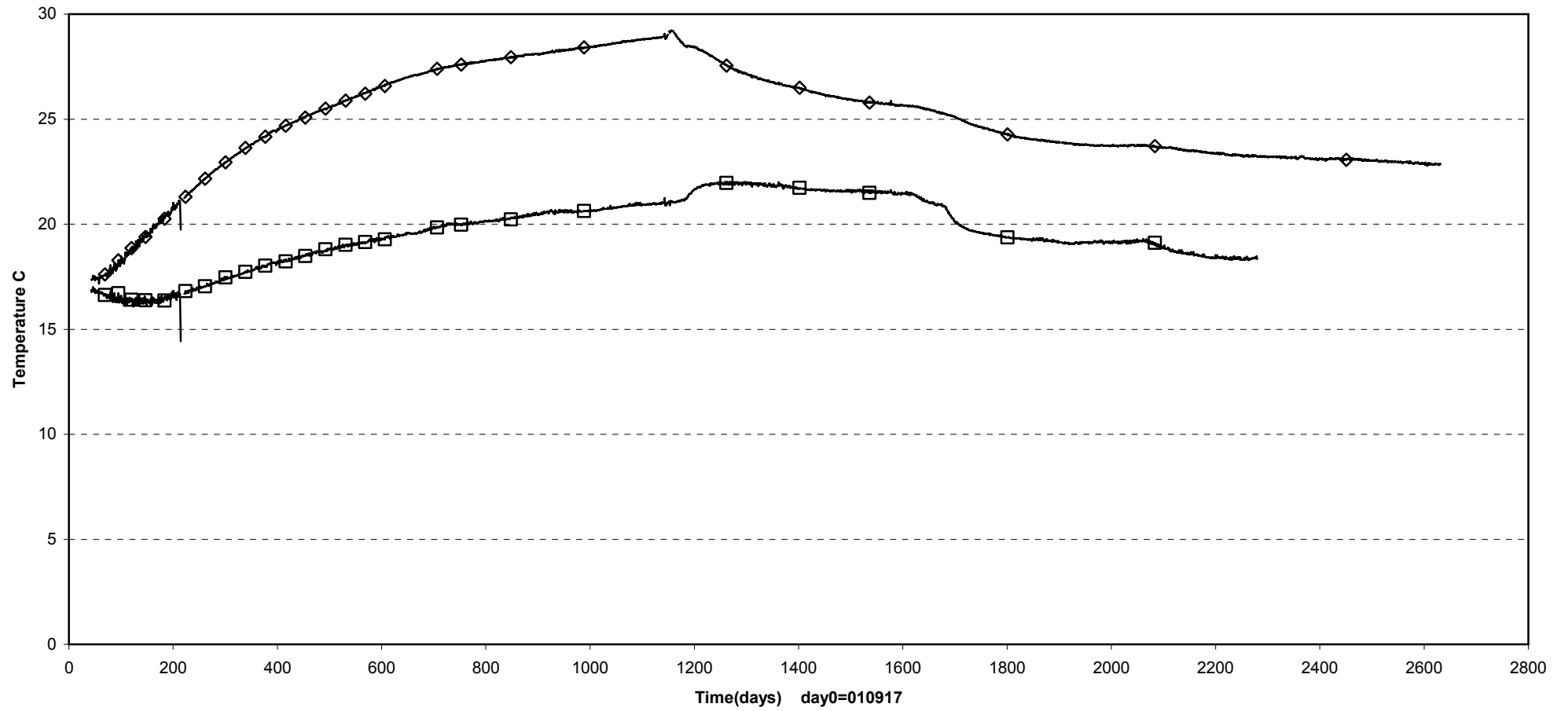

□ TBA10010(F2-3\0\1.15\3578) ◇ TBA10011(F2-3\0\1.24\3578)

Prototype\ Backfill \ Above dep.hole3 (010917-081201)
 Temperature - Pentronic

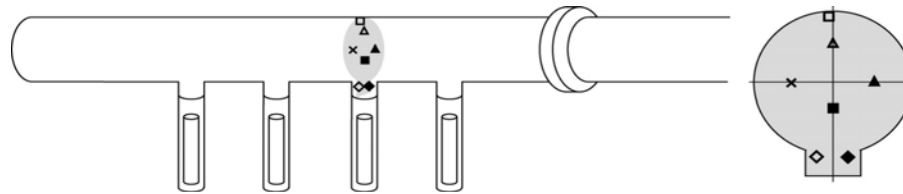
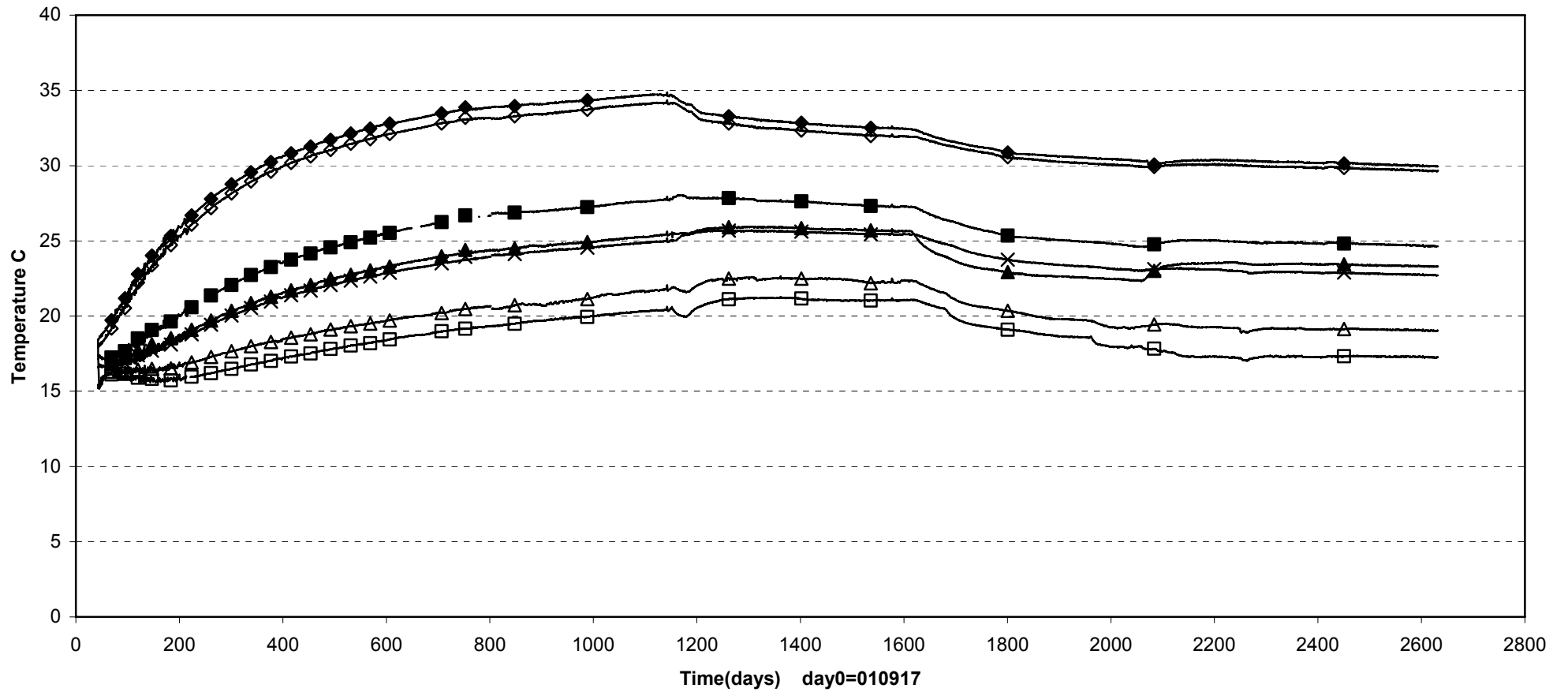

- | | | | |
|-----------------------------|---------------------------|---------------------------|-----------------------------|
| □ TBA10012(E3\0.1\2.3\3575) | △ TBA10013(E3\0.1.3\3575) | ■ TBA10014(E3\0\0.9\3575) | ◇ TBA10015(E3\0.5\2.6\3575) |
| ◆ TBA10016(E3\0.5\2.6\3575) | × TBA10017(E3\1.3\0\3575) | ▲ TBA10018(E3\1.3\0\3575) | |

Prototype\ Backfill \ Between dep.hole 3-4 (010917-081201)
 Temperature - Pentronic

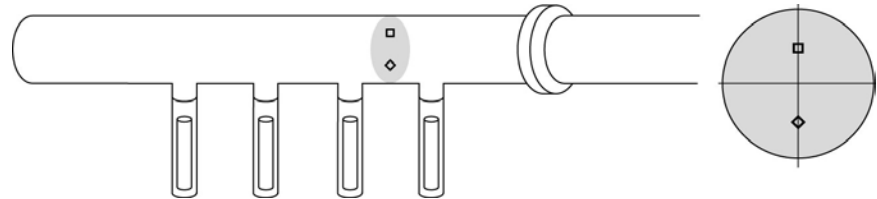
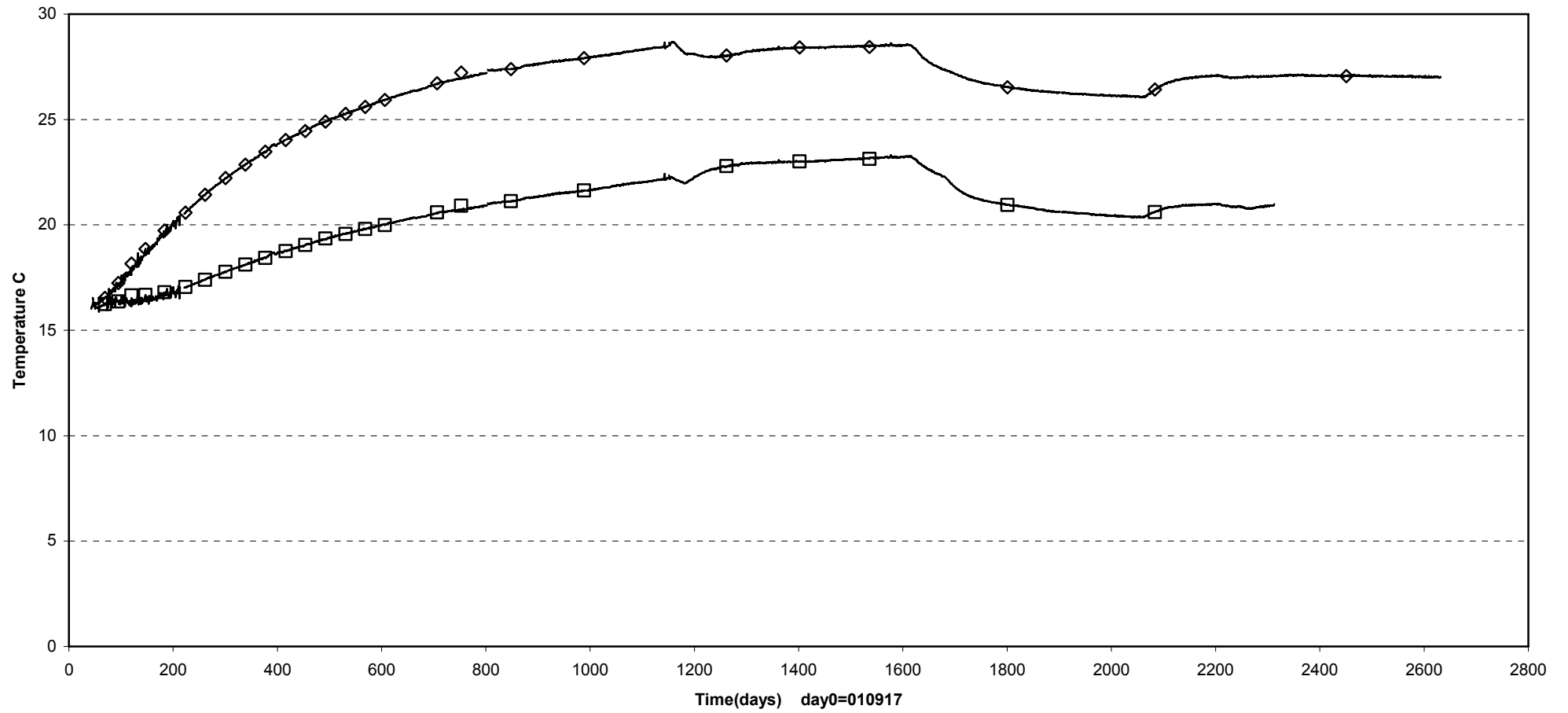

□ TBA10019(F3-4\0\1.2\3572) ◇ TBA10020(F3-4\0\1.3\3572)

Appendix 5

Dep. hole 5

Prototype\Hole 5\Cyl.1 (030508-081201)
 Total pressure - Geokon

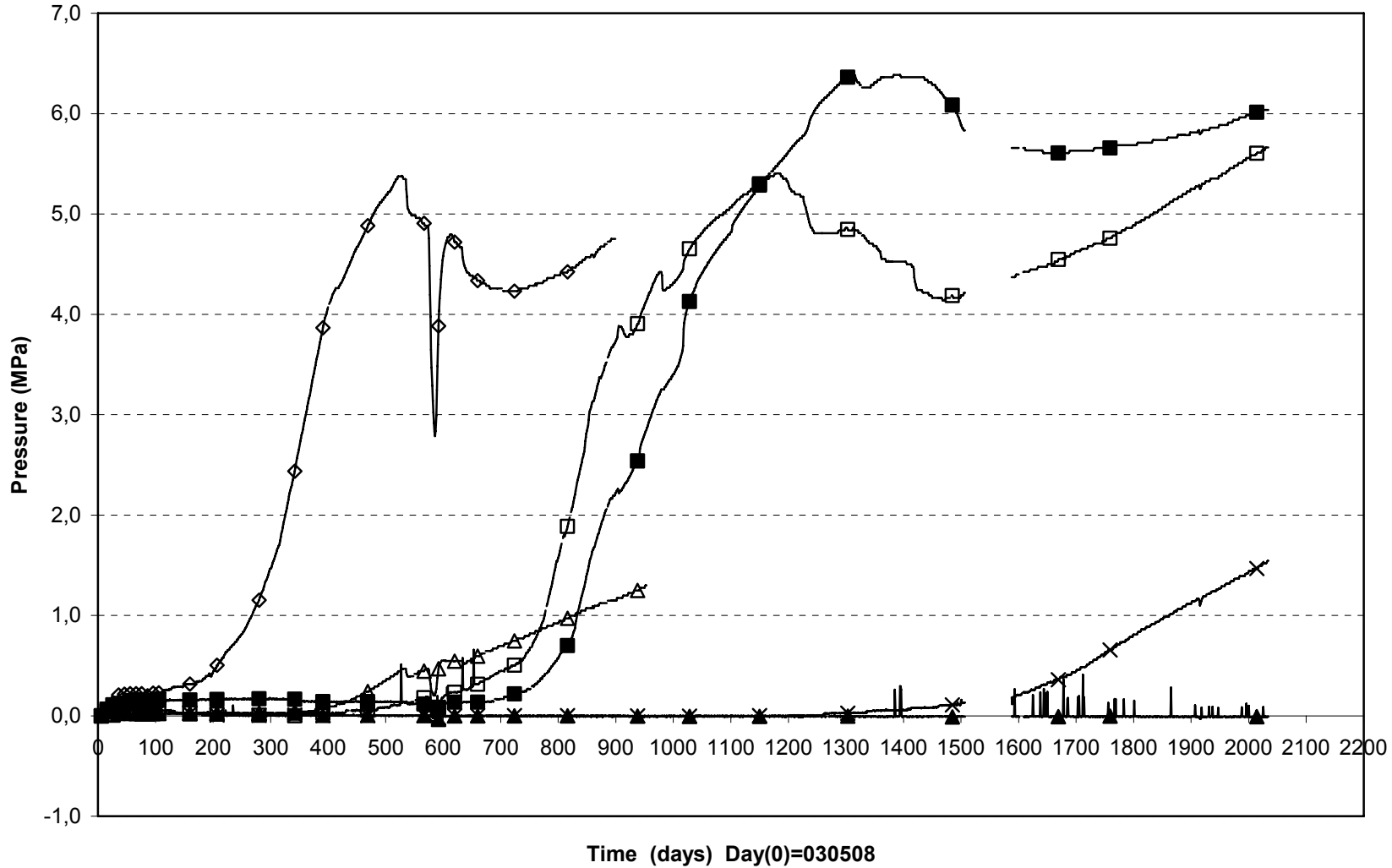

×PB501(0\0°\0)	▲PB502(0.500\0°\0.100)	◇PB506(0.500\95°\0.635)
△PB507(0.500\105°\0.735)	□PB508(0.500\185°\0.635)	■PB509(0.500\195°\0.735)

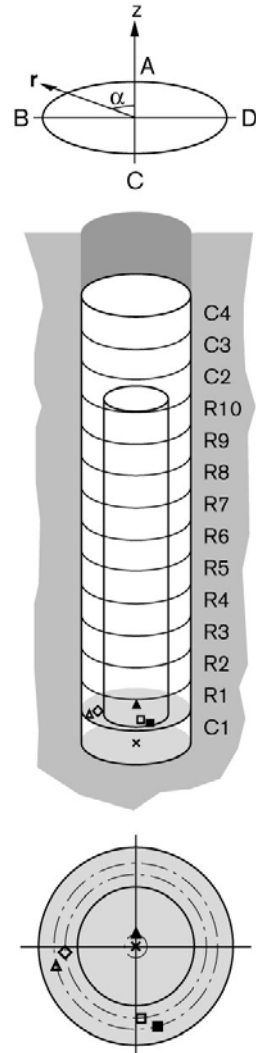

Prototype\Hole 5\Ring5 (030508-081201)

Total pressure - Geokon

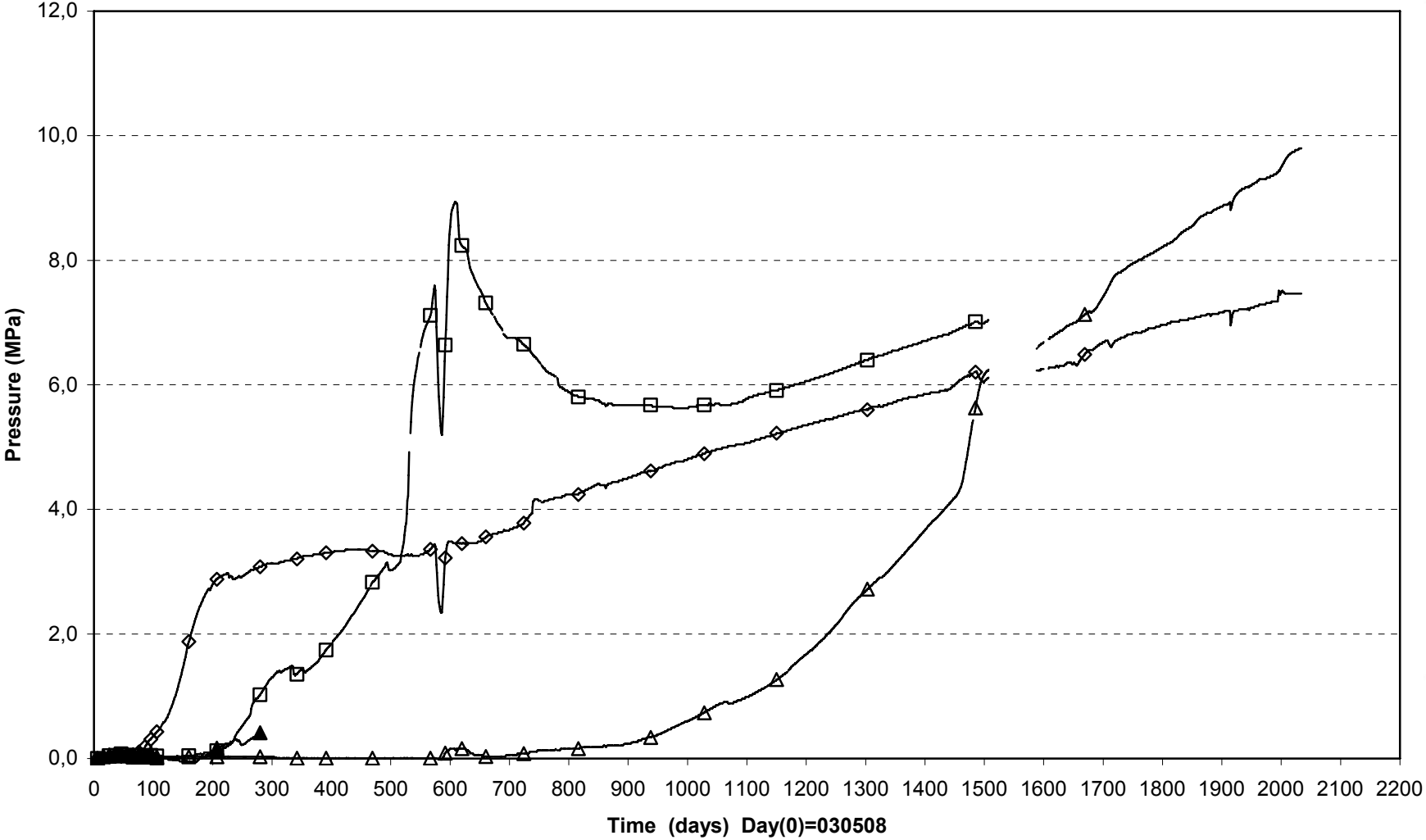

□ PB511(3.036\5°\0.685)	▲ PB513(3.036\95°\0.635)
◇ PB514(3.036\95°\0.785)	△ PB515(3.036\185°\0.635)

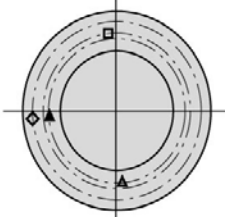
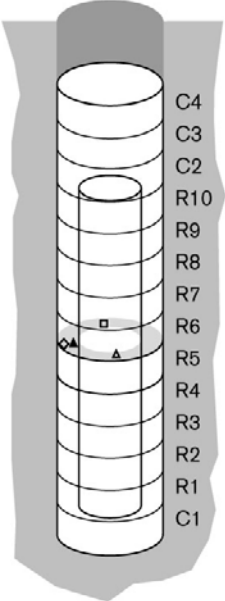
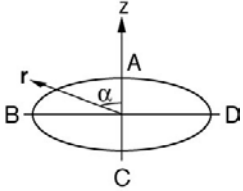

Prototype\Hole 5\Ring10 (030508-081201)
Total pressure - Geokon

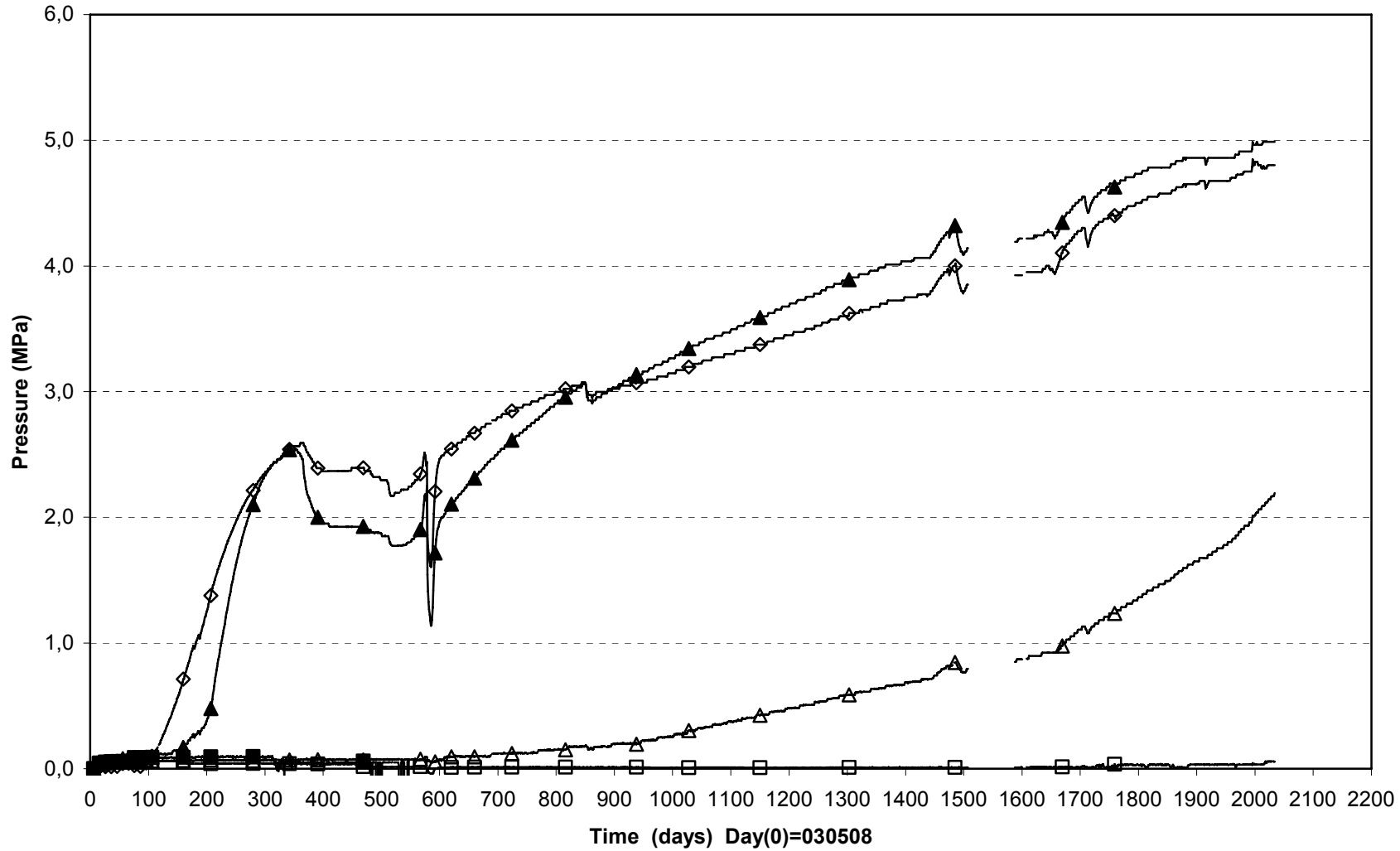

□ PB517(5.593\0°\0.050)	▲ PB521(5.593\95°\0.635)	◇ PB522(5.593\105°\0.735)
△ PB523(5.593\180°\0.635)	■ PB524(5.593\190°\0.735)	

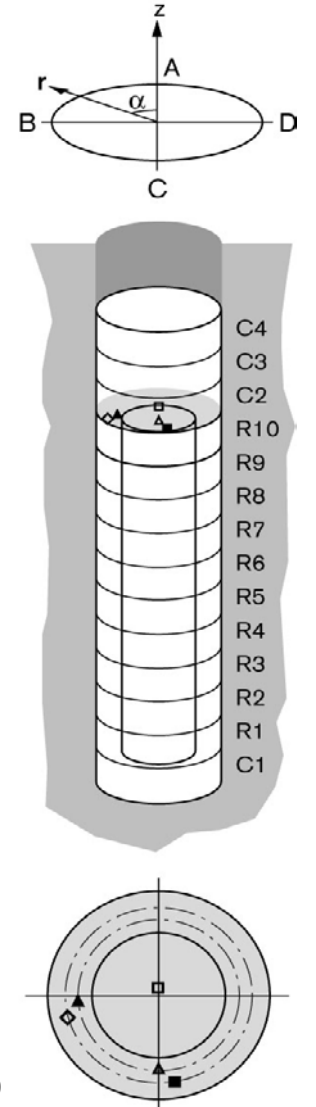

Prototype\Hole 5\Cyl.3 and Cyl.4 (030508-081201)
 Total pressure - Geokon

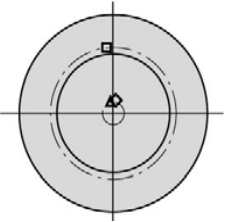
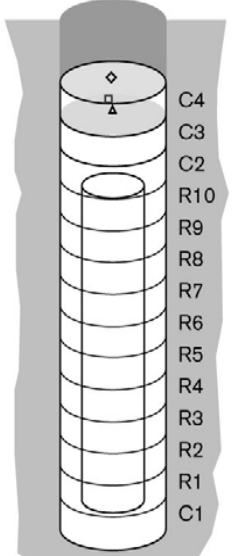
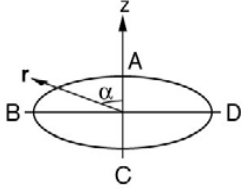
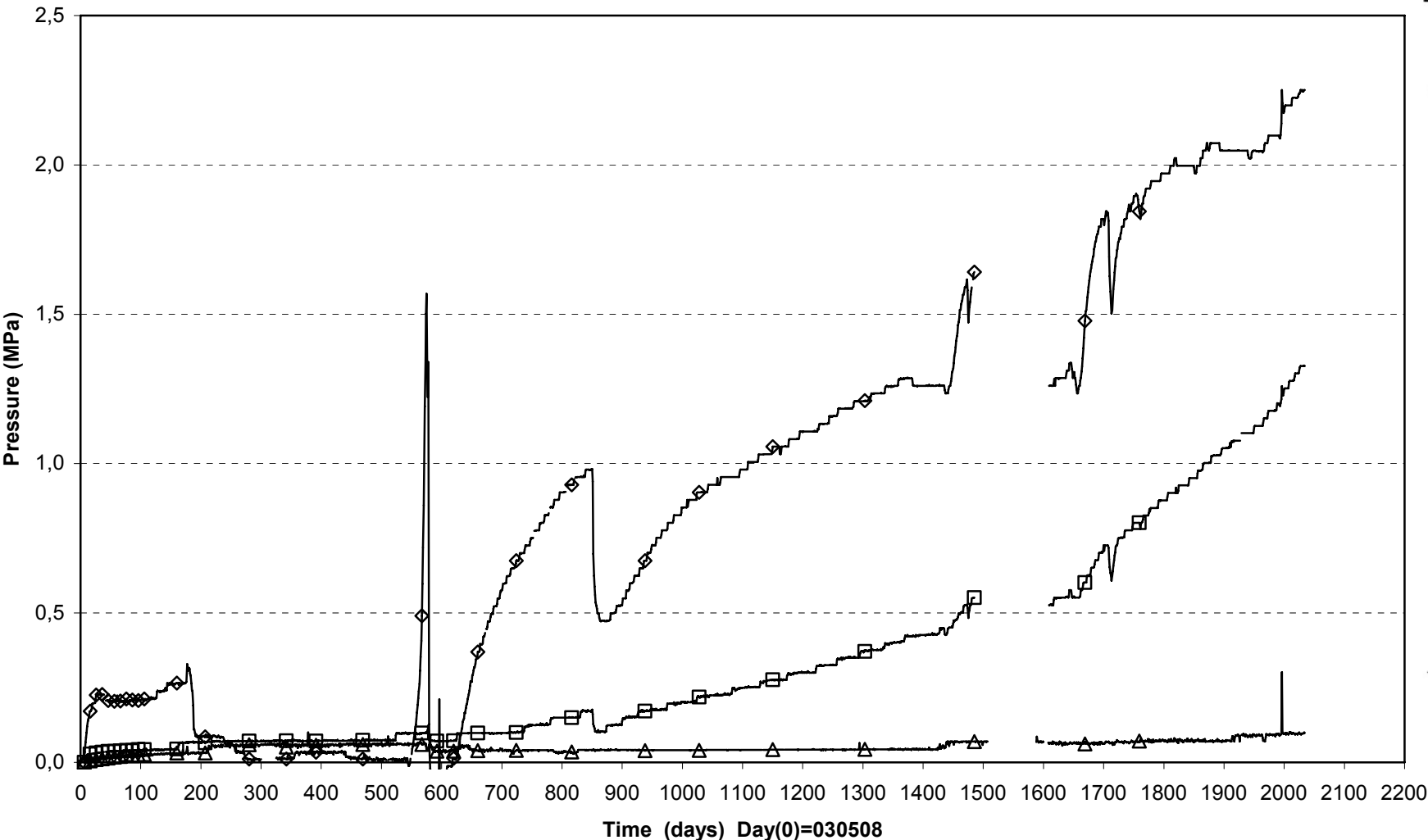

△ PB525(6.603\0°\0.100)
□ PB526(6.603\5°\0.585)
◇ PB527(7.110\0°\0.100)

Prototype\ Hole 5 (030508-081201)
 Total pressure - Kulite

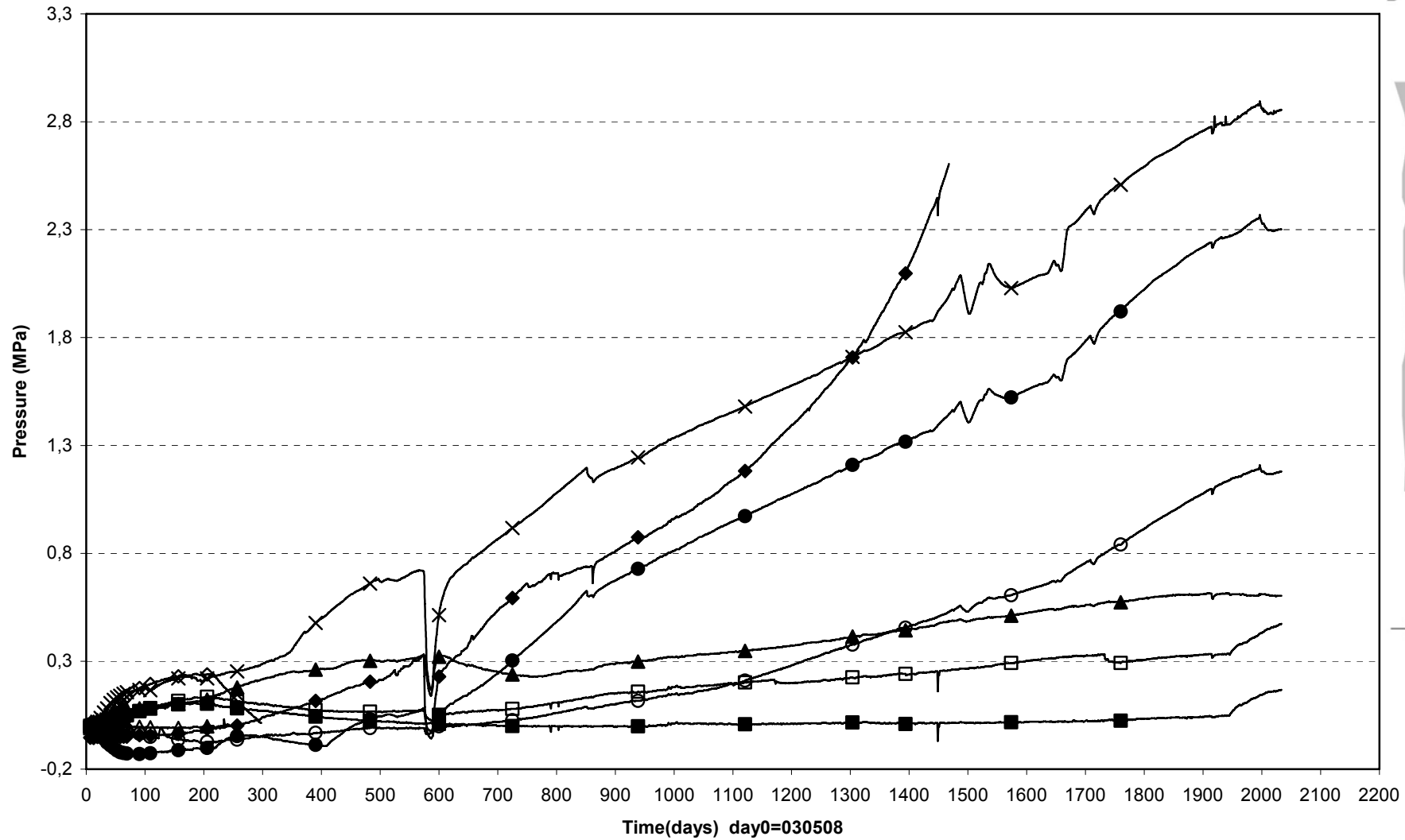

- | | | | | |
|-----------------------------|----------------------------|----------------------------|----------------------------|---------------------------|
| □ PB503(0.340 \5°\ 0.585) | ■ PB504(0.340 \5°\ 0.685) | ◇ PB505(0.340 \5°\ 0.785) | ◆ PB510(2.876 \10°\ 0.535) | △ PB512(2.876 \5°\ 0.825) |
| ▲ PB516(2.876 \190°\ 0.825) | ○ PB518(5.433 \10°\ 0.585) | ● PB519(5.433 \10°\ 0.685) | × | × |

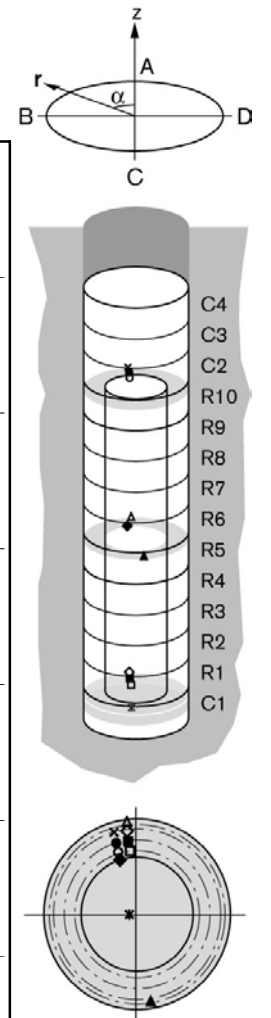

Prototype\Hole 5\Cyl.1 (030508-081201)
Relative humidity - Vaisala

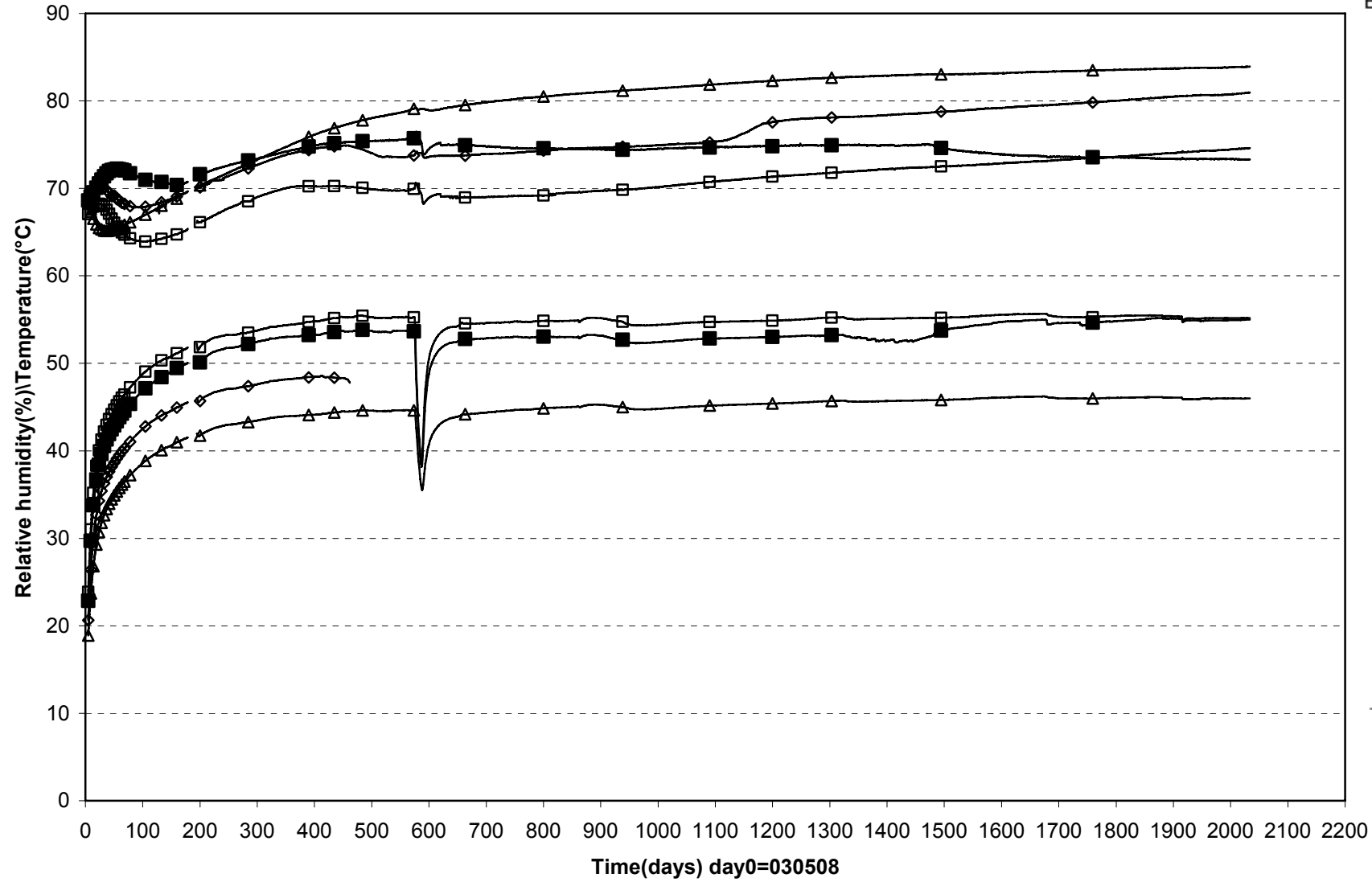

□ WB504(0.340\350°\0.585) ◇ WB505(0.340\350°\0.685) △ WB506(0.340\350°\0.785) ■ WB507(0.340\80°\0.585)

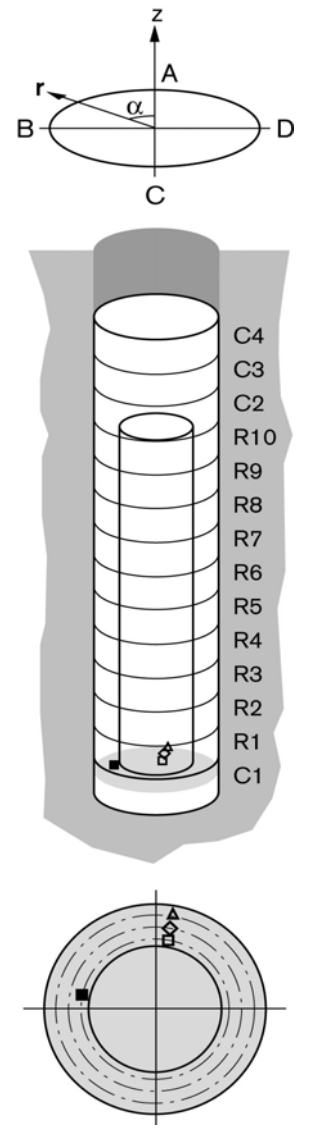

Prototype\Hole 5\Ring 5 (030508-081201)
Relative humidity - Vaisala

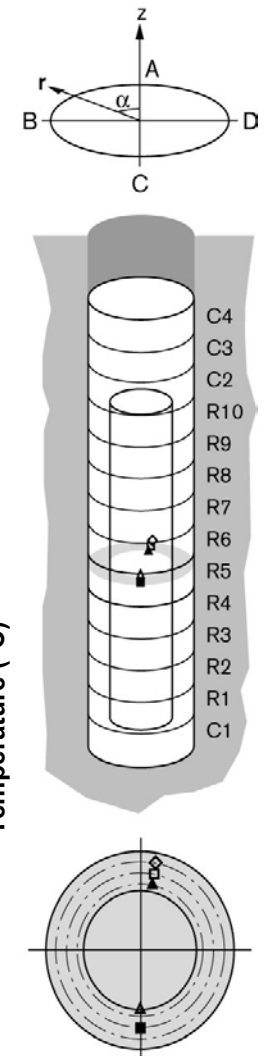
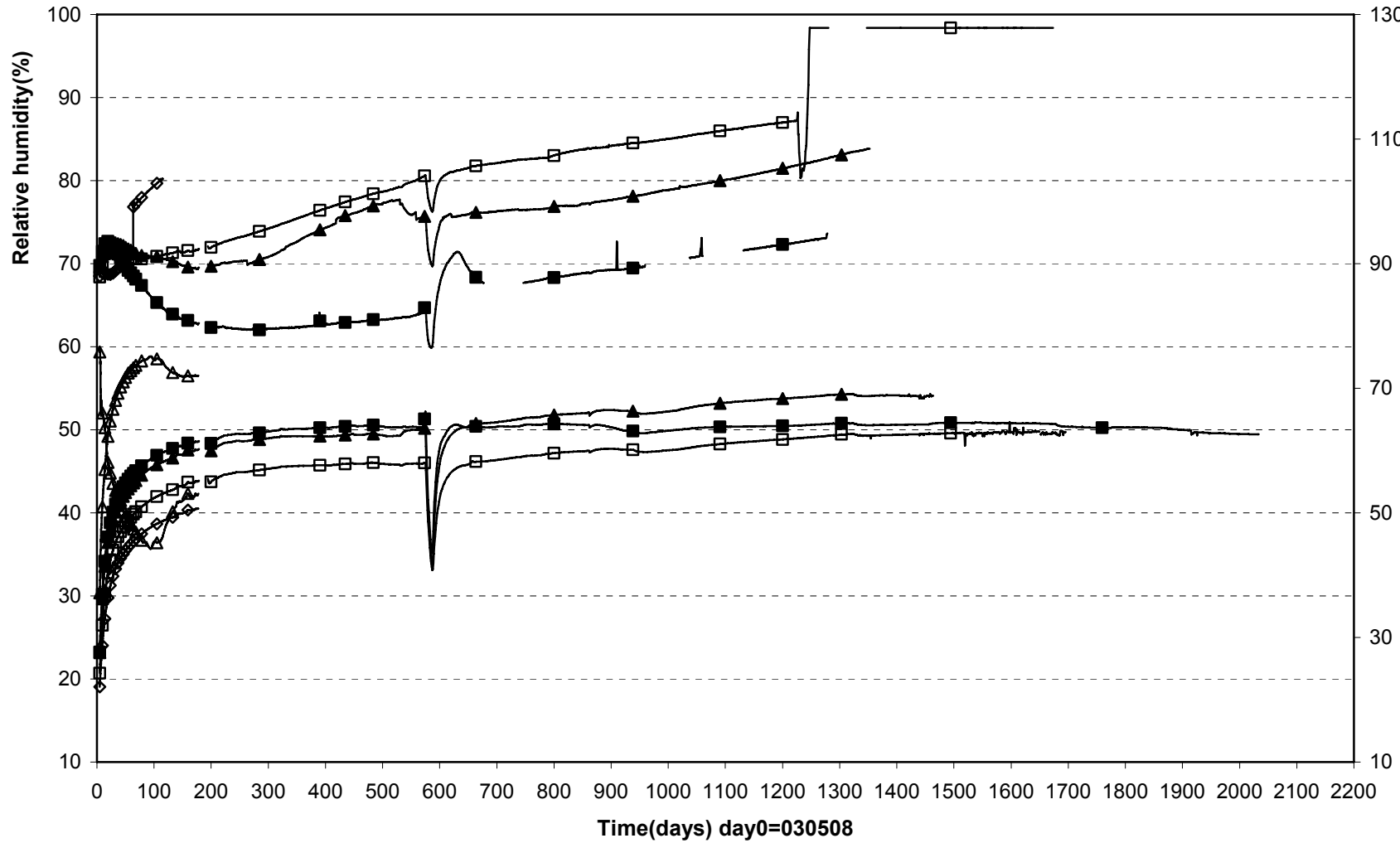

▲ WB513(2.876\350°\0.585) □ WB514(2.876\350°\0.685) ◇ WB515(2.876\350°\0.785) △ WB519(2.876\180°\0.535\In the slot) ■ WB520(2.876\180°\0.685)

Prototype\Hole 5\Ring 10 (030508-081201)
 Relative humidity - Vaisala

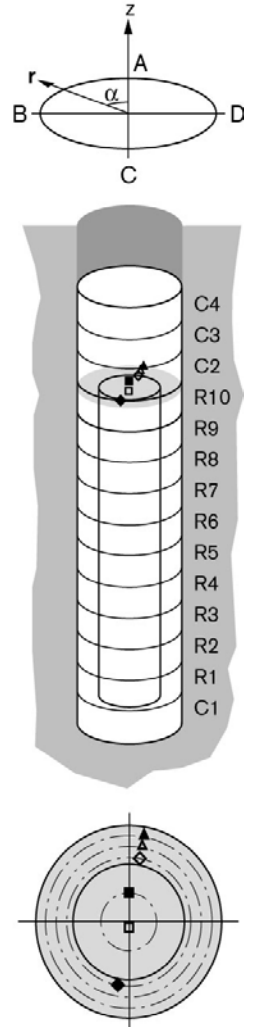
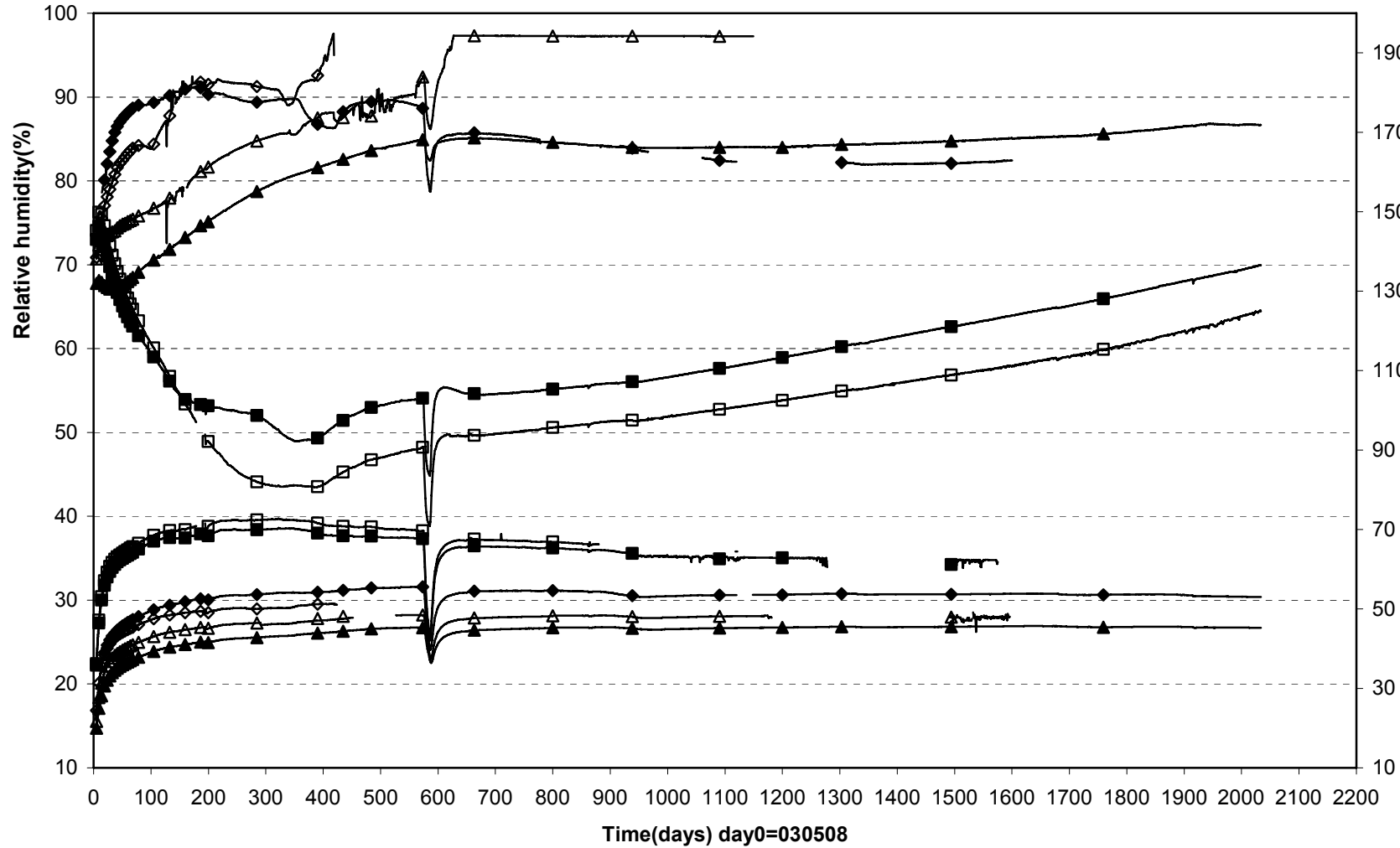

□ WB522(5.433\180°\0.050) ■ WB523(5.433\ 0° \0.262) ◇ WB524(5.433\350°\0.585) △ WB525(5.433\350°\0.685) ▲ WB526(5.433\350°\0.785) ◆ WB530(5.433\170°\0.585)

Prototype\Hole 5\Cyl.3 and Cyl.4 (030508-081201)
 Relative humidity - Vaisala

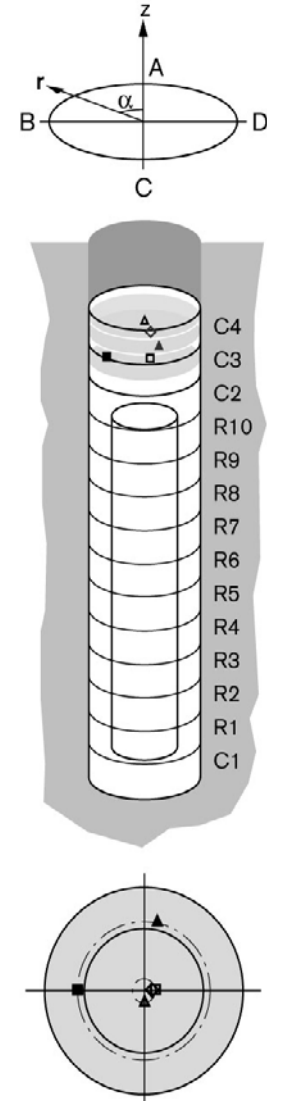
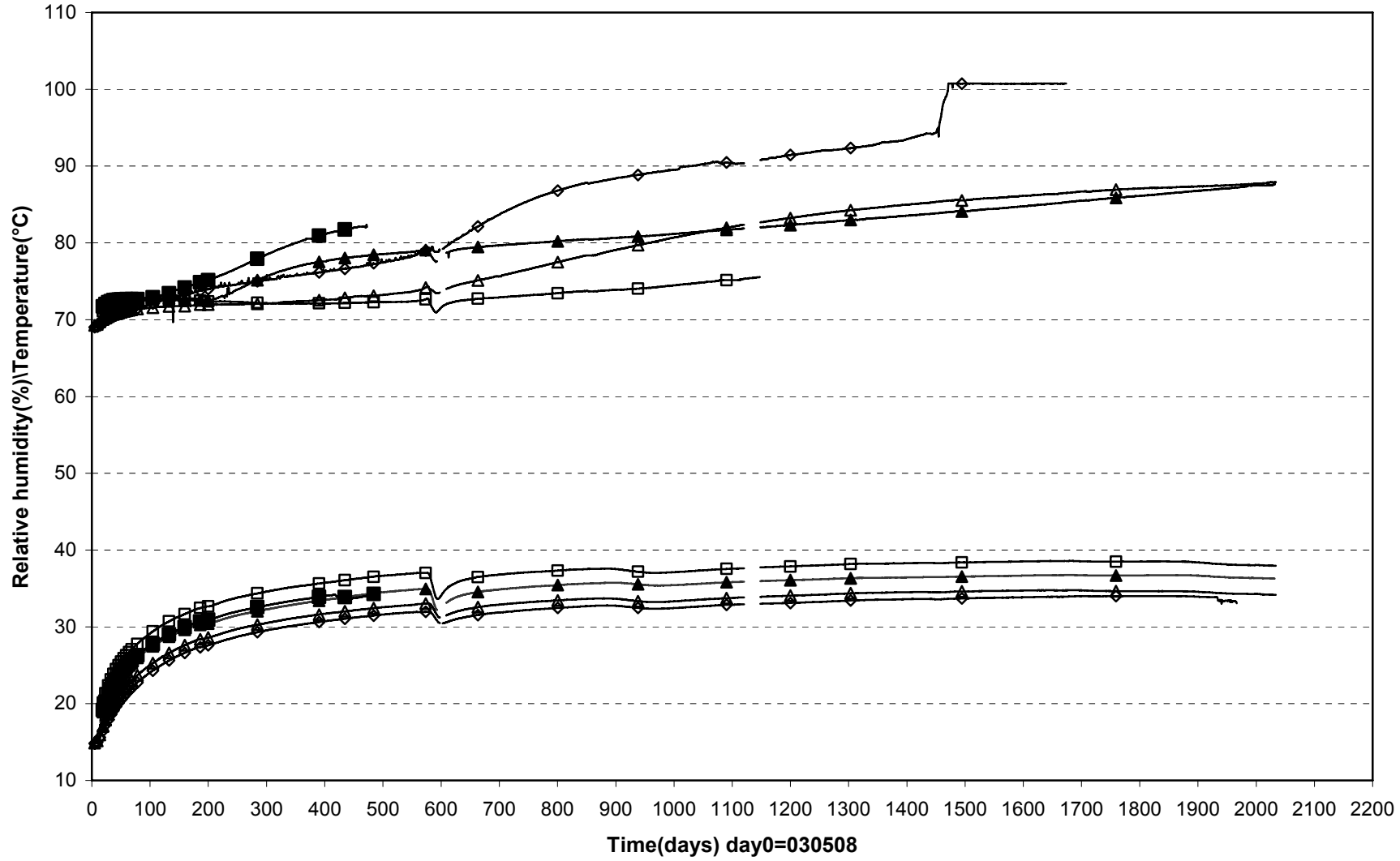

□ WB532(6.353\270°\0.100) ▲ WB533(6.353\350°\0.585) ■ WB534(6.353\90°\0.585) △ WB536(6.790\180°\0.100) ◇ WB537(6.950\270°\0.100)

Prototyp\Hole 5\Cyl.1 (030508-081201)
 Relative humidity - Rotronic

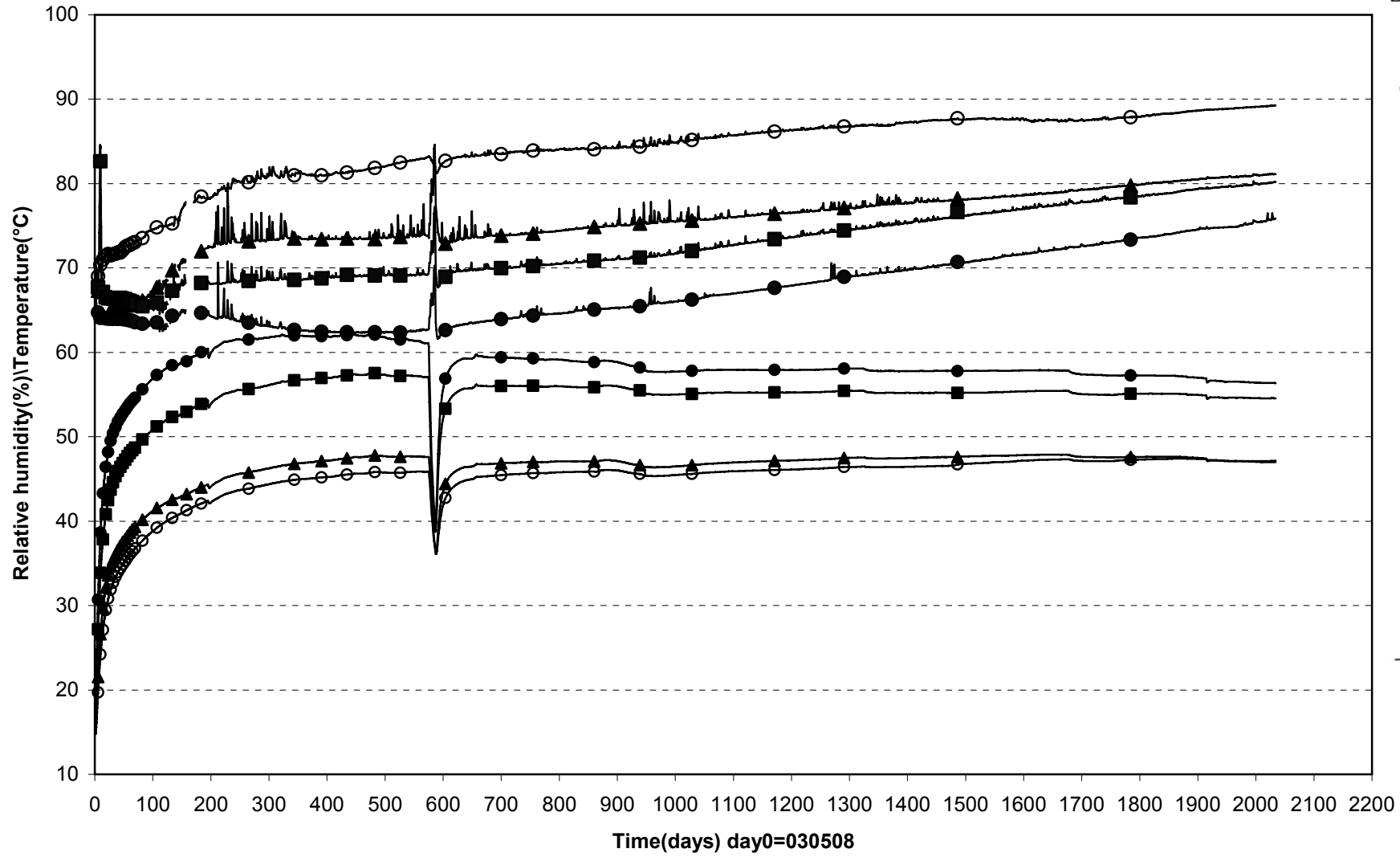

● WB501 (0.250\180°\0.050) ▲ WB502 (0.05\180°\0.100) ■ WB503 (0.250\180°\0.400) ○ WB508(0.250\80°\0.685)

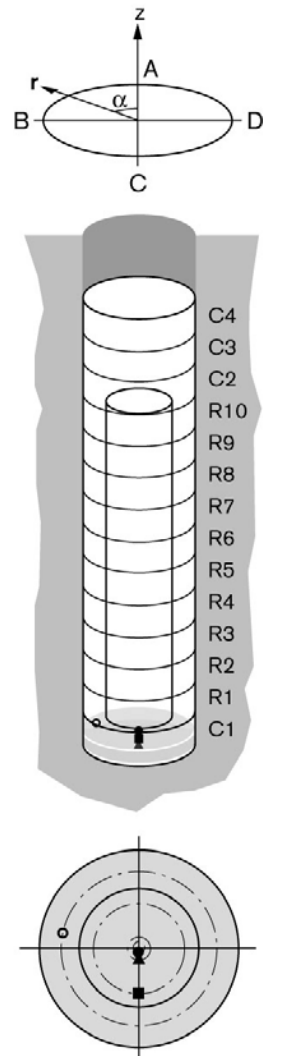

Prototyp\Hole 5\Cyl.1 (030508-081201)
 Relative humidity - Rotronic

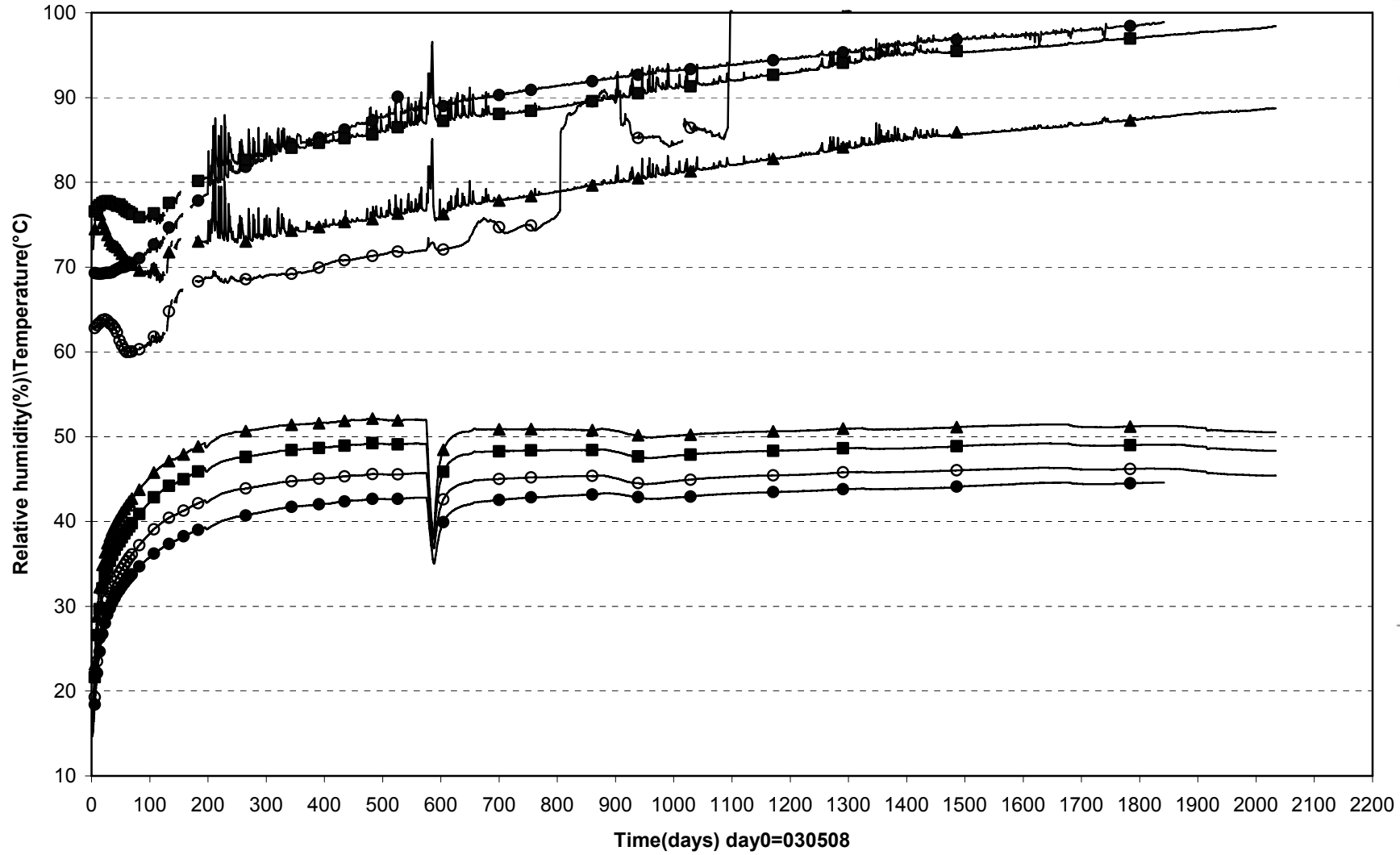

● WB509(0.250\80°\0.785) ▲ WB510(0.250\170°\0.585) ■ WB511(0.250\170°\0.685) ○ WB512(0.250\170°\0.785)

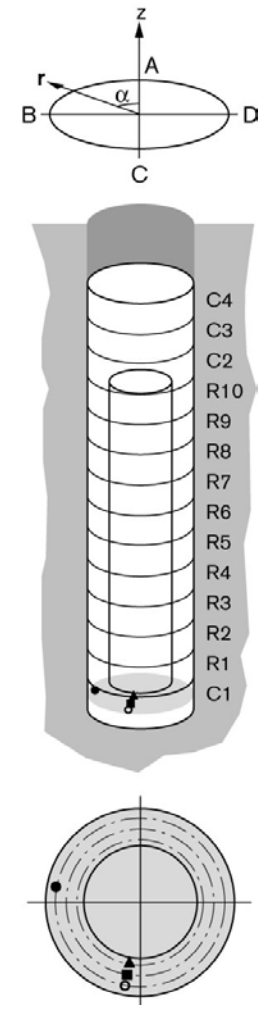

Prototyp\Hole 5\Ring5 (030508-081201)
 Relative humidity - Rotronic

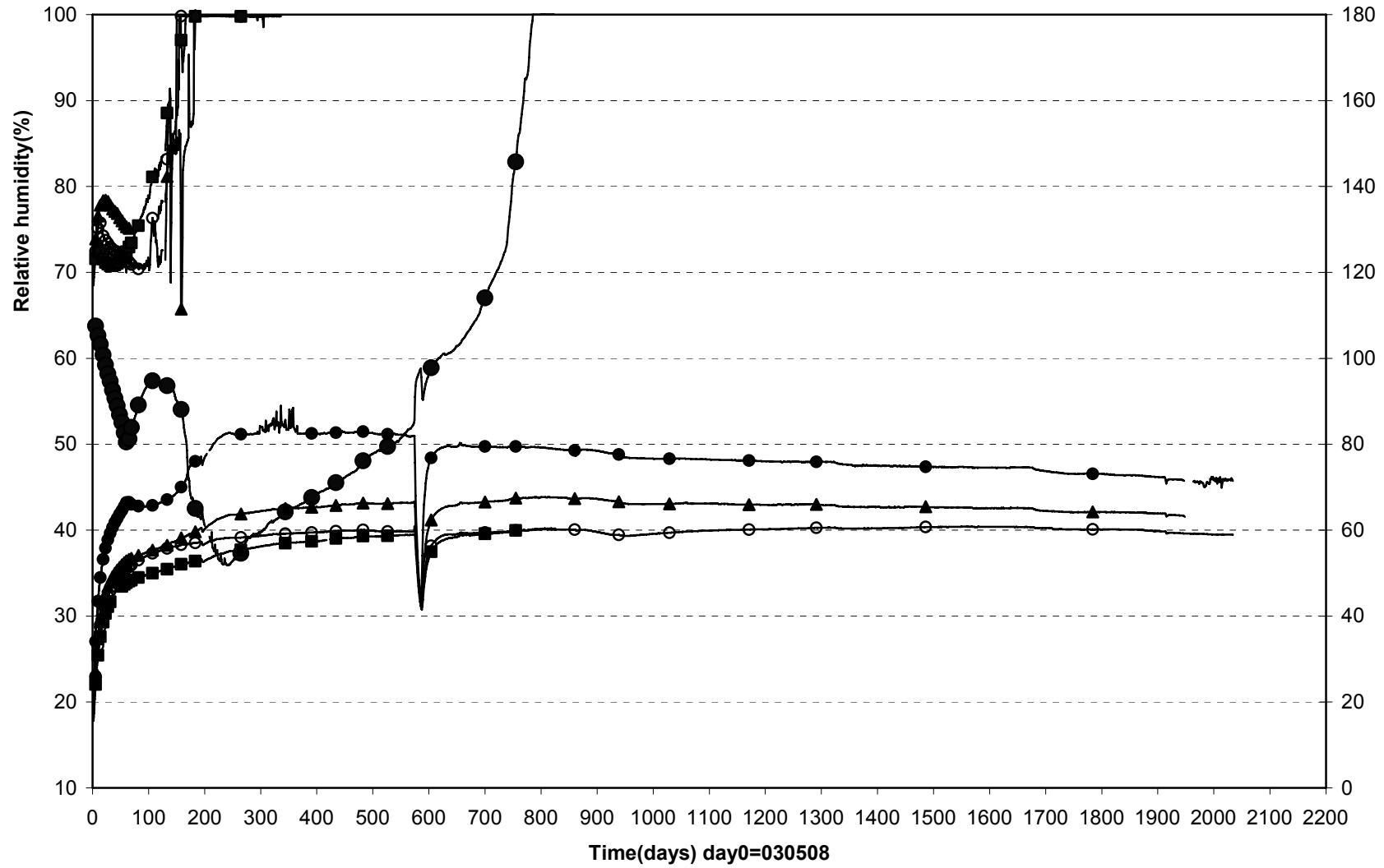

● WB516(2.786\80°\0.535) ▲ WB517(2.786\80°\0.685) ■ WB518(2.786\80°\0.785) ○ WB521(2.786\180°\0.785)

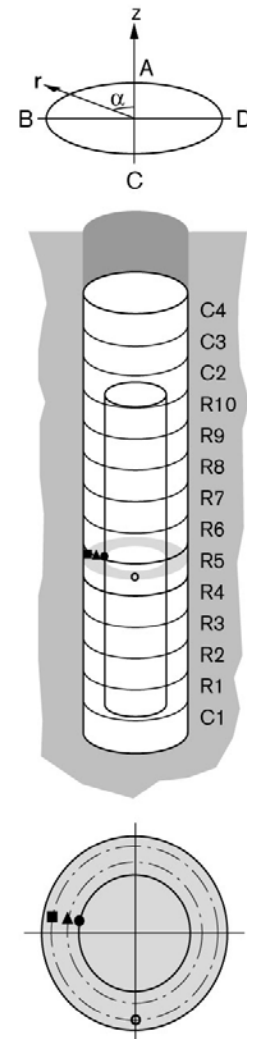

Prototyp\Hole 5\Ring10 (030508-081201)
 Relative humidity - Rotronic

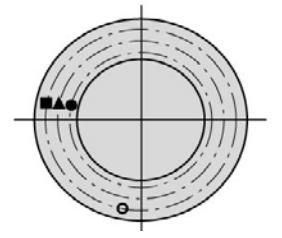
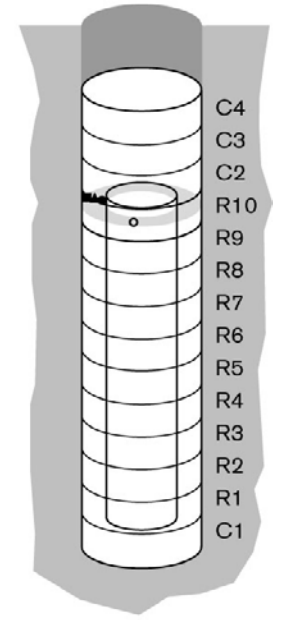
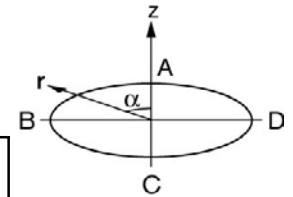
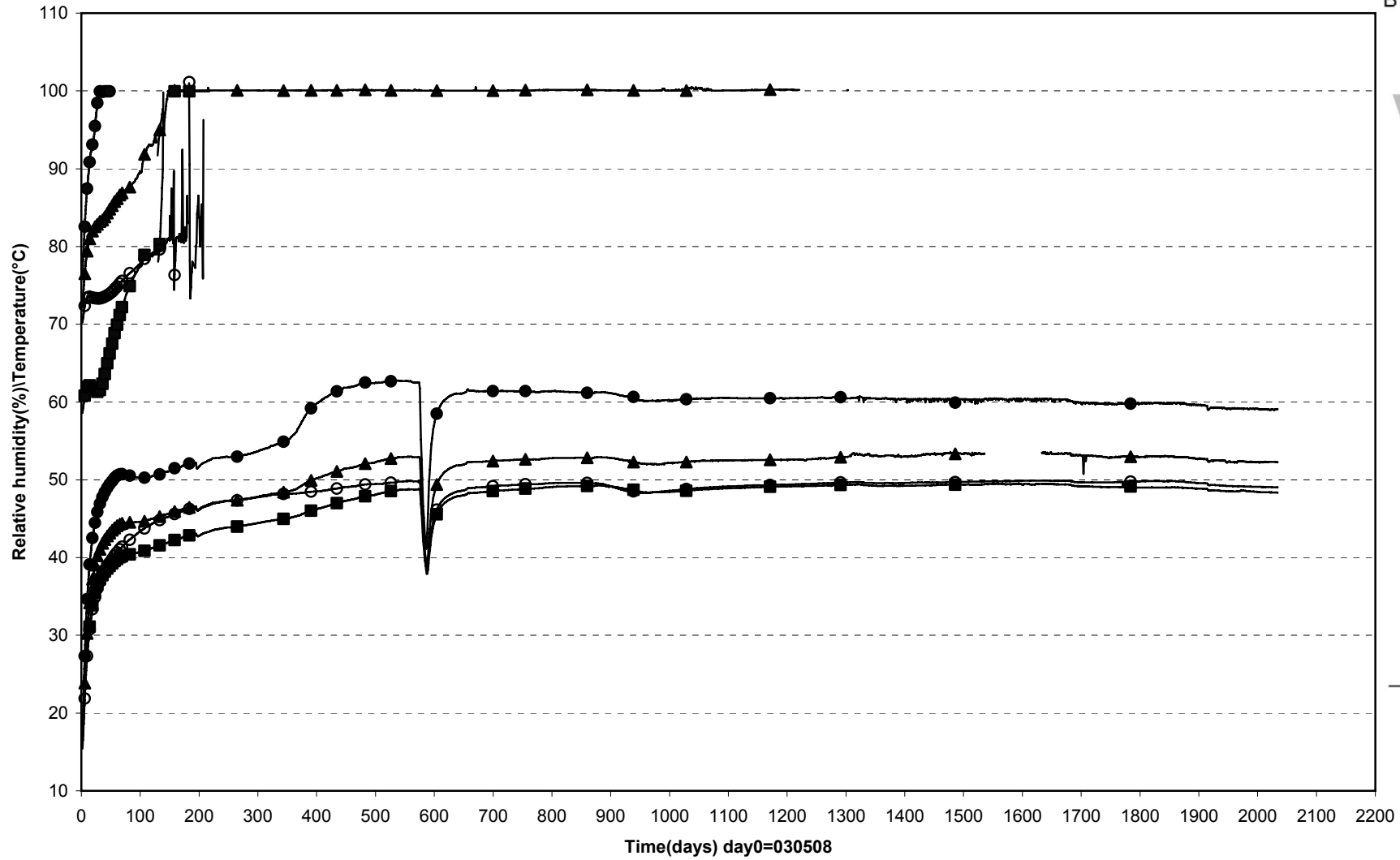

● WB527(5.343\80°\0.585) ▲ WB528(5.343\80°\0.685) ■ WB529(5.343\80°\0.785) ○ WB531(5.343\170°\0.785)

Prototyp\Hole 5\Cyl.3 (030508-081201)
 Relative humidity - Rotronic

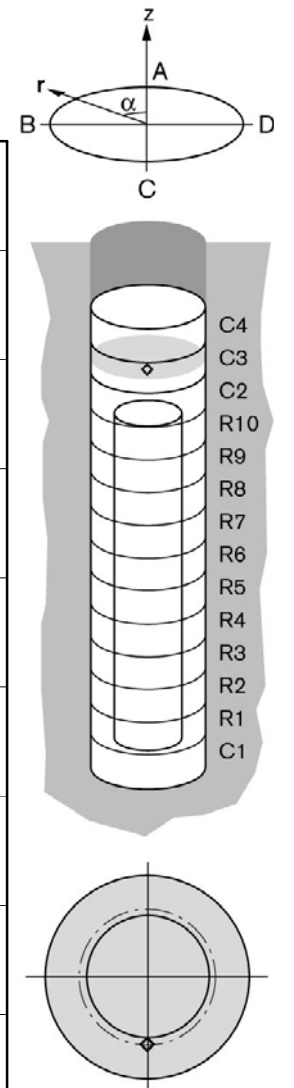
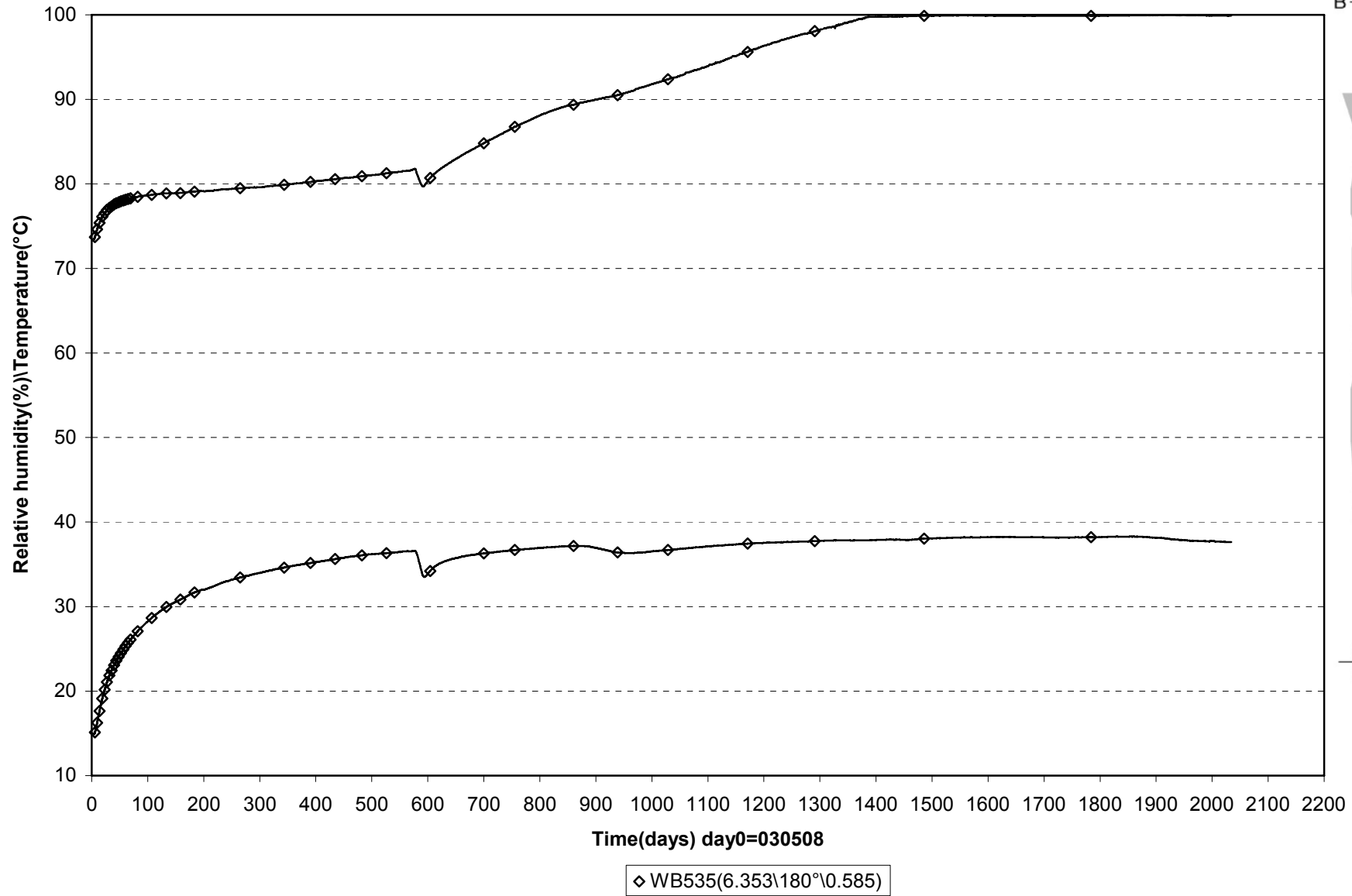

Prototype\ Hole 5 \ Ring 3 (030508-081201)
Suction - Wescor

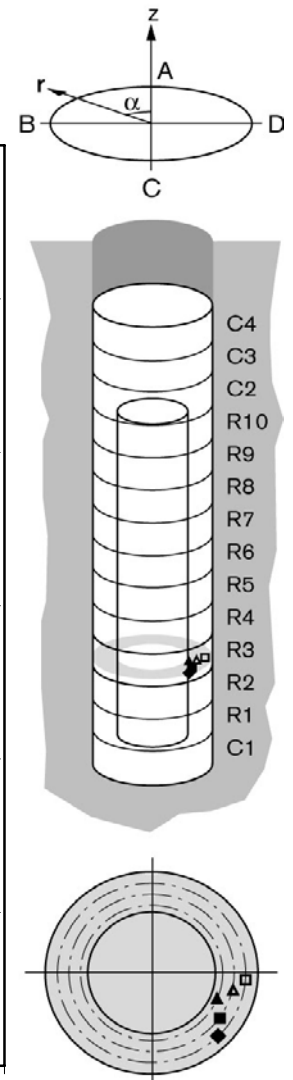
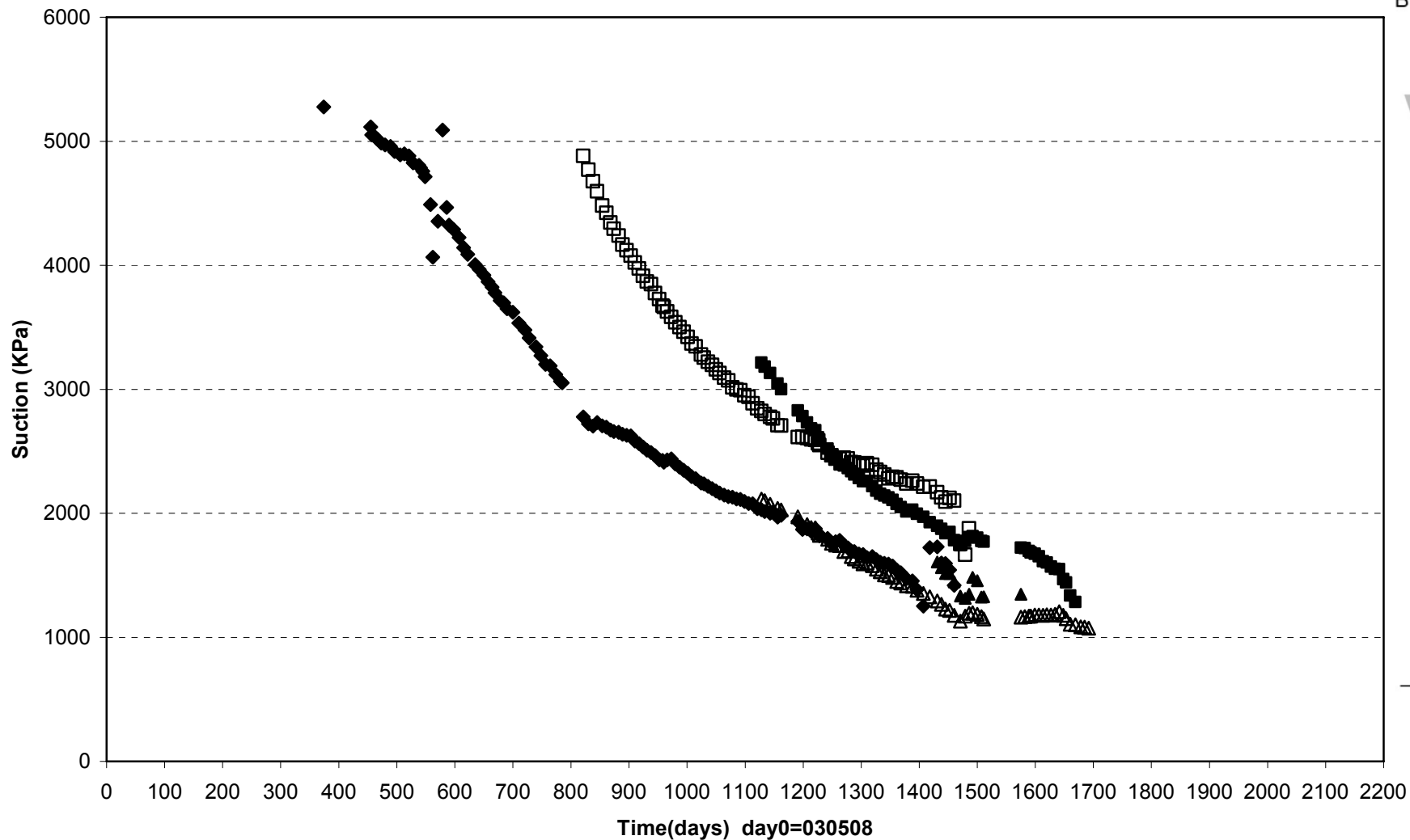

◆ WB538(1.624\225°\0.775) ■ WB539(1.624\235°\0.680) ▲ WB540(1.624\245°\0.585) △ WB541(1.624\255°\0.680) □ WB542(1.624\265°\0.775)

Prototype\Hole5 (030508-081201)
Pore pressure - Geokon

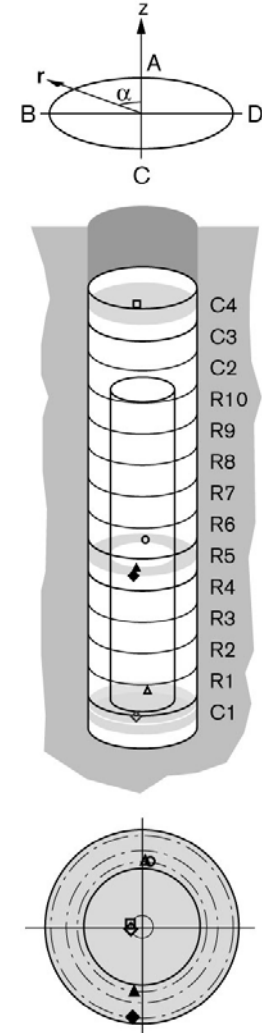
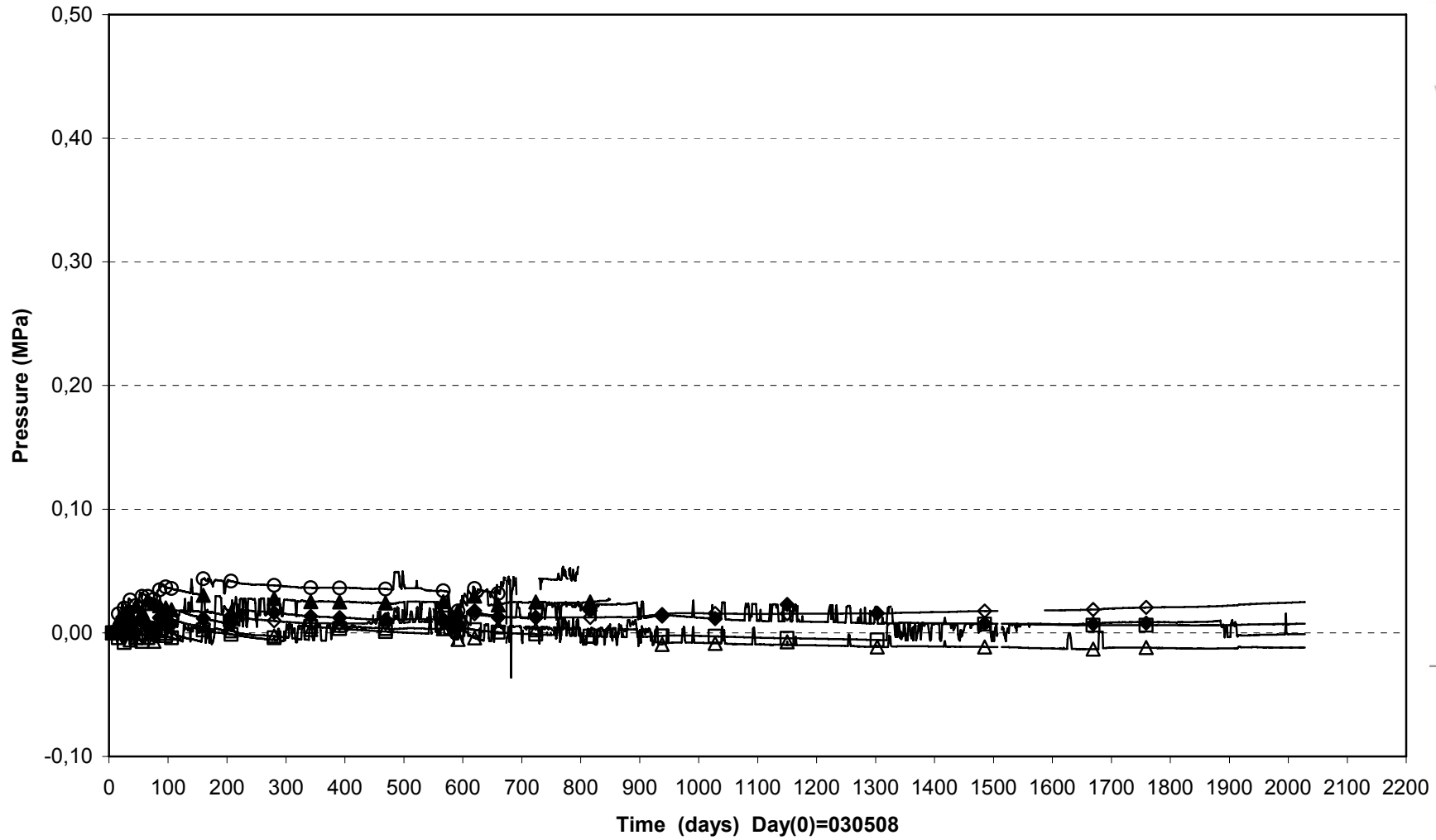

◇ UB502(0.050\90°\0.100)	△ UB503(0.250\355°\0.585)	○ UB505(2.786\355°\0.585)
▲ UB509(2.786\175°\0.535)	◆ UB510(2.786\175°\0.825)	□ UB514(6.860\90°\0.100)

Prototype\ Hole 5 (030508-081201)
Pore pressure - Kulite

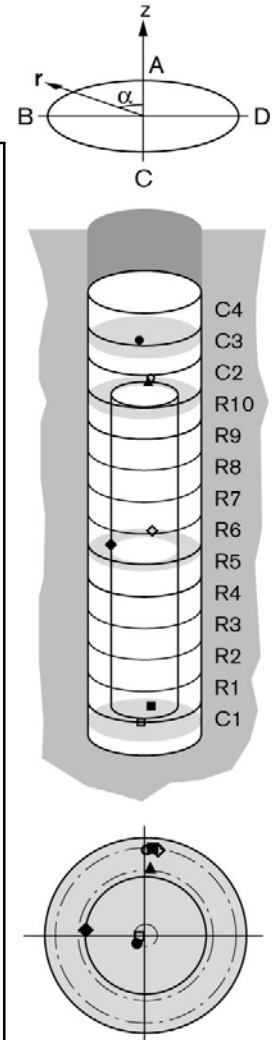
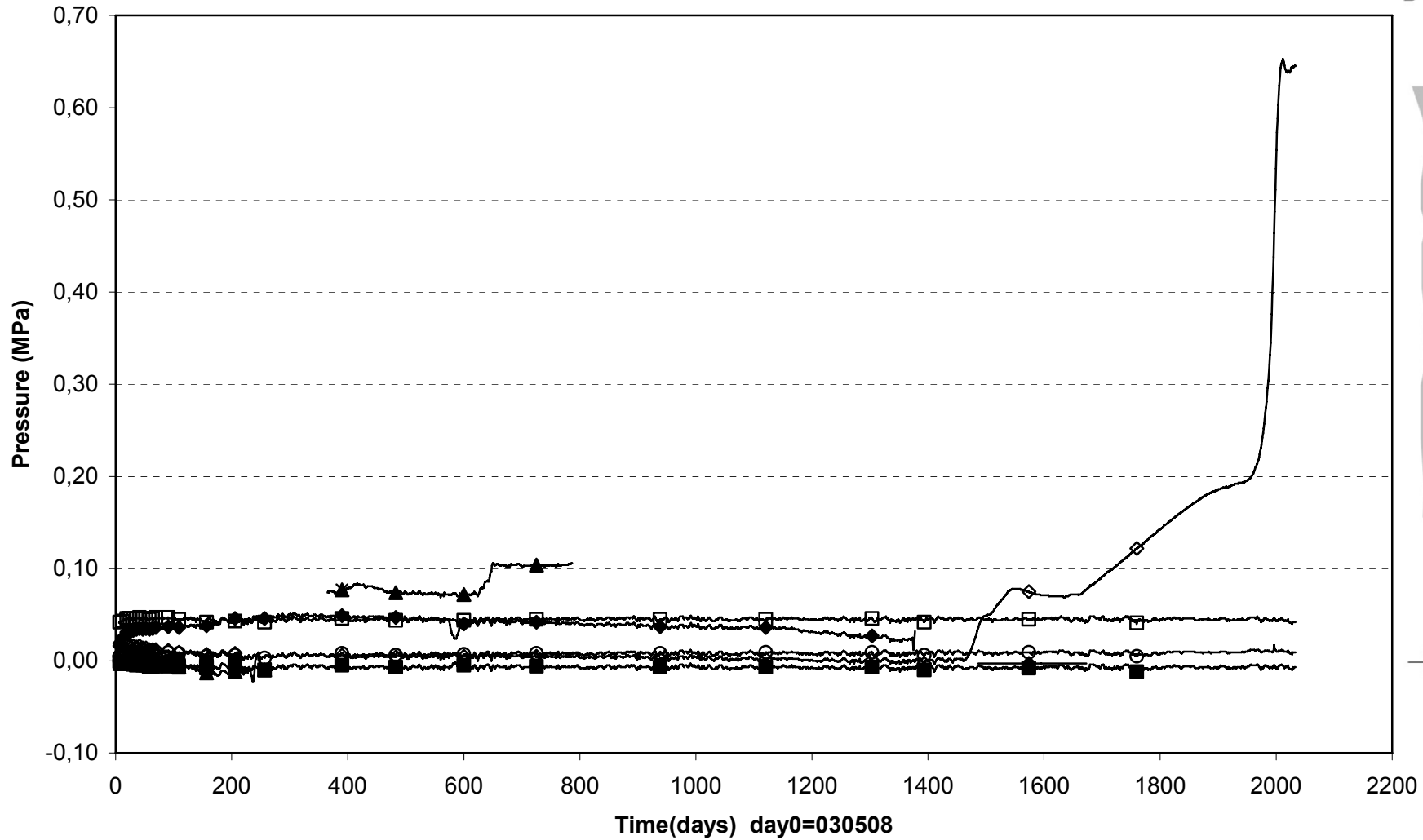

□ UB501(0.250 \ 90° \ 0.050) ■ UB504(0.340 \ 355° \ 0.785) ◇ UB506(2.876 \ 355° \ 0.785) ◆ UB507(2.876 \ 85° \ 0.535)
 ▲ UB511(5.433 \ 355° \ 0.585) ○ UB512(5.433 \ 355° \ 0.785) ● UB513(6.250 \ 135° \ 0.100)

Prototype\Hole 5\Cyl.1 (030508-081201)
 Temperature - Pentronic

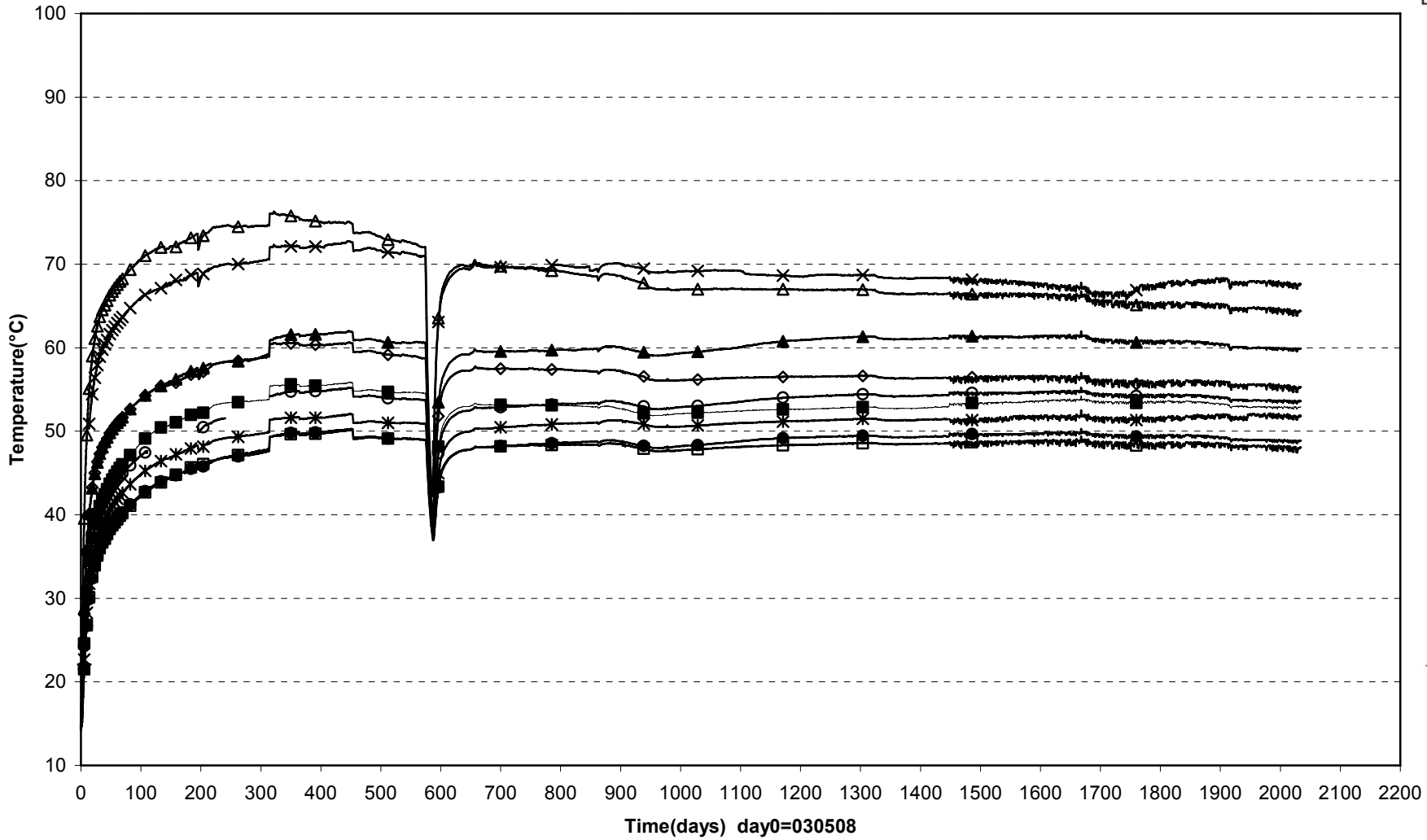

- TB501(0.080\270°\0.050) ◇ TB502(0.250\270°\0.060) △ TB503(0.450\270°\0.070) × TB504(0.450\355°\0.525) * TB505(0.450\355°\0.685)
- + TB506(0.450\85°\0.685) ■ TB507(0.450\175°\0.685) ▲ TB508(0.450\270°\0.585) ○ TB509(0.450\270°\0.685) ● TB510(0.450\270°\0.785)

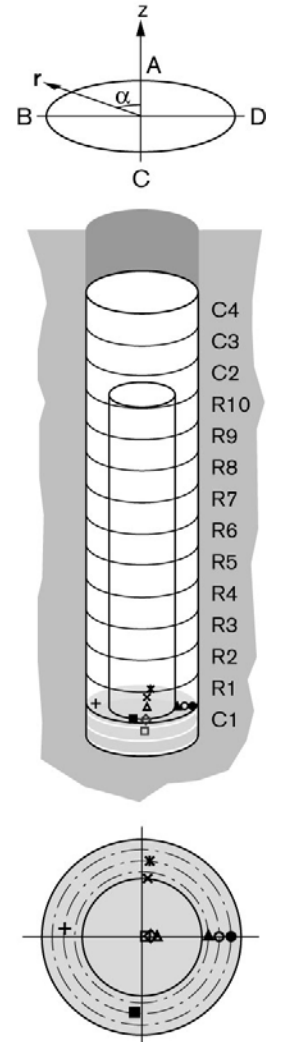

Prototype\Hole 5 \Ring5 (030508-081201)
 Temperature - Pentronic

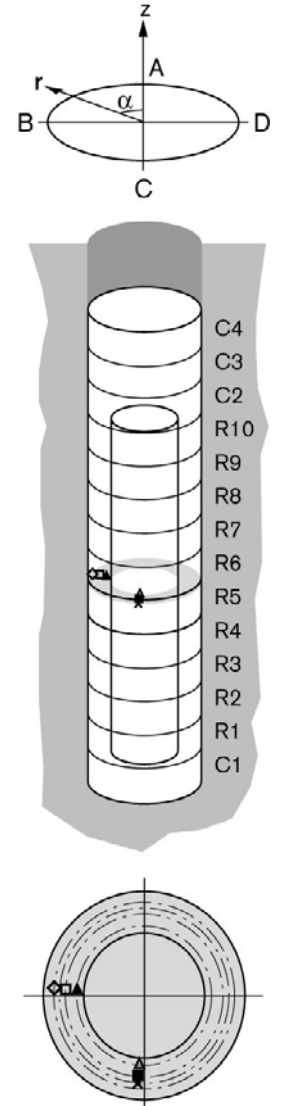
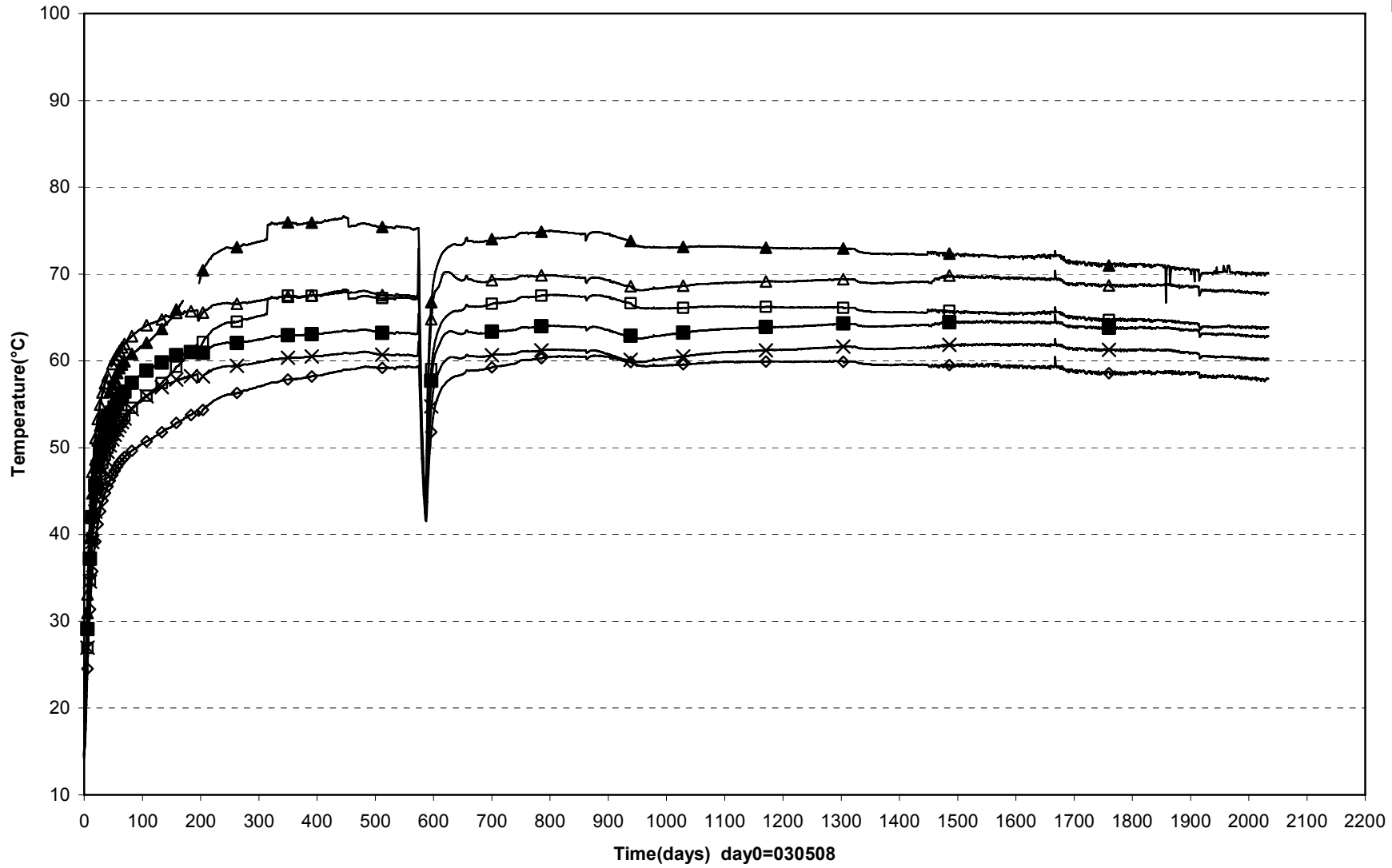

Prototype\Hole 5 \Ring5 (030508-081201)
 Temperature - Pentronic

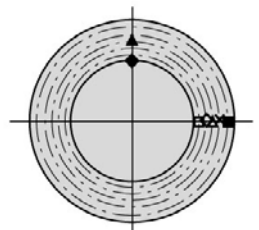
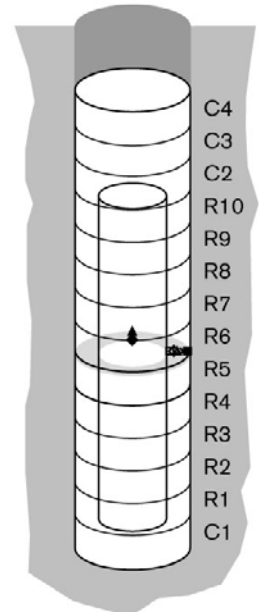
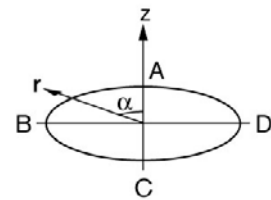
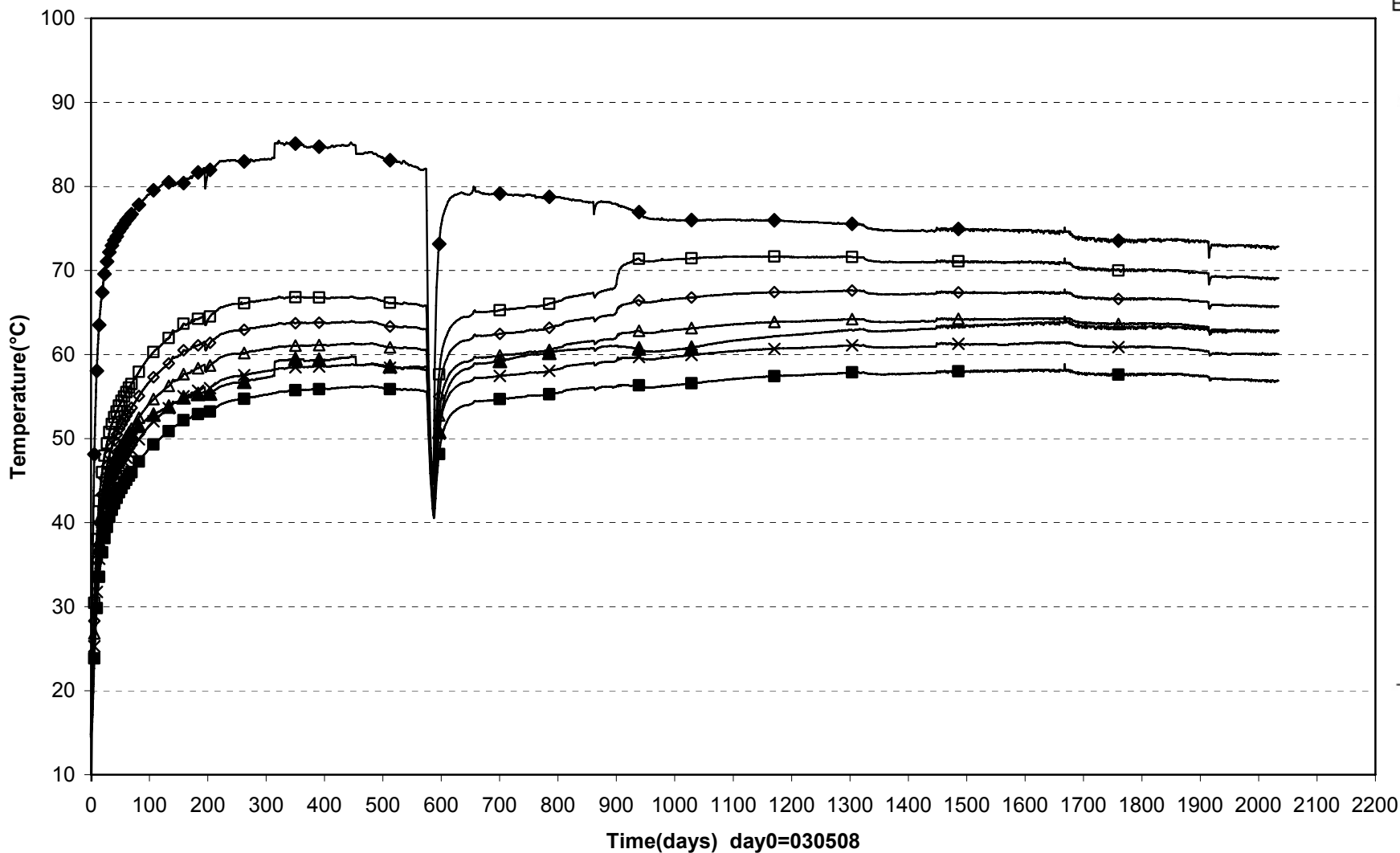

□ TB519(2.986\270°\0.585) ◇ TB520(2.986\270°\0.635) △ TB521(2.986\270°\0.685) × TB522(2.986\270°\0.735) ■ TB523(2.986\270°\0.785)
 ◆ TB511(2.950\0°\0.525) ▲ TB512(2.986\0°\0.685)

Prototype\Hole 5 \Ring10 (030508-081201)
 Temperature - Pentronic

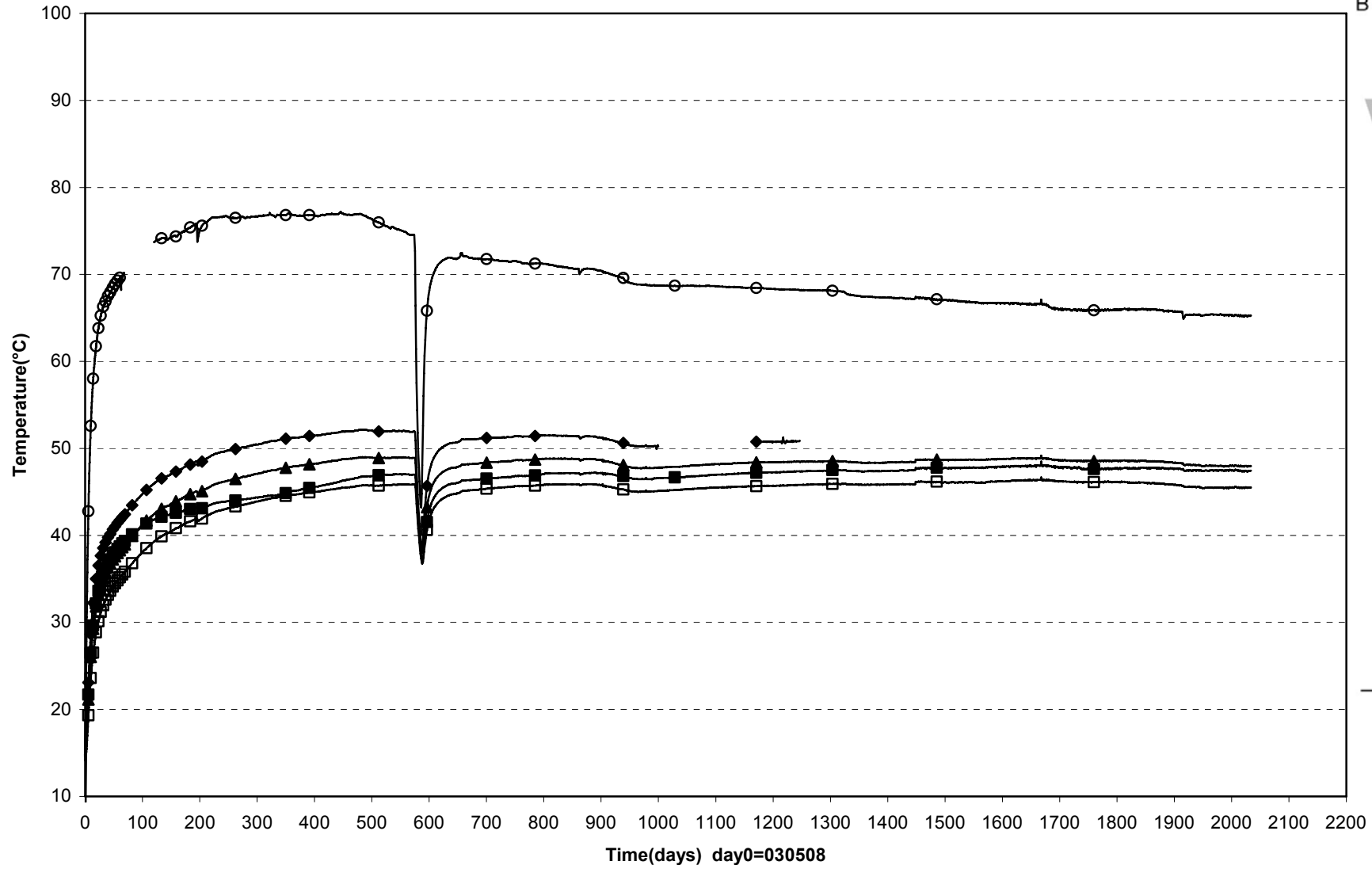

○ TB524(5.150\ 0°\0.525) ■ TB525(5.543\ 0°\0.685) ◆ TB526(5.543\ 270°\0.585) ▲ TB527(5.543\ 270°\0.685) □ TB528(5.543\ 270°\0.785)

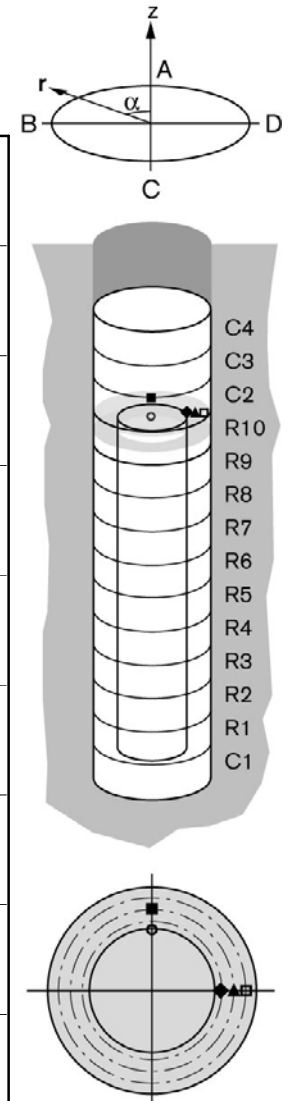

Prototype\Hole 5 \Cyl.3 and Cyl.4 (030508-081201)
 Temperature - Pentronic

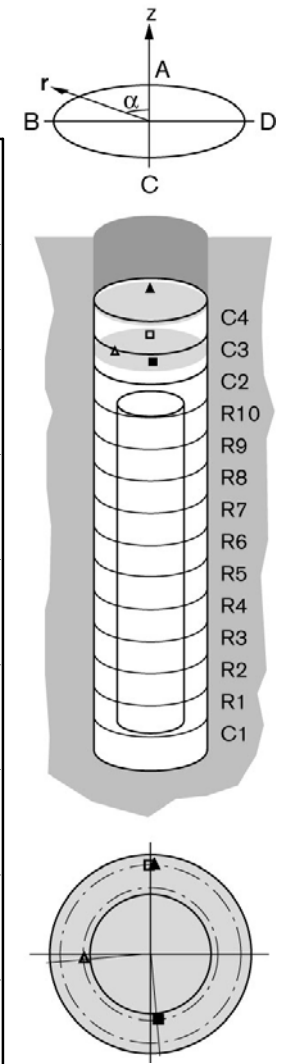
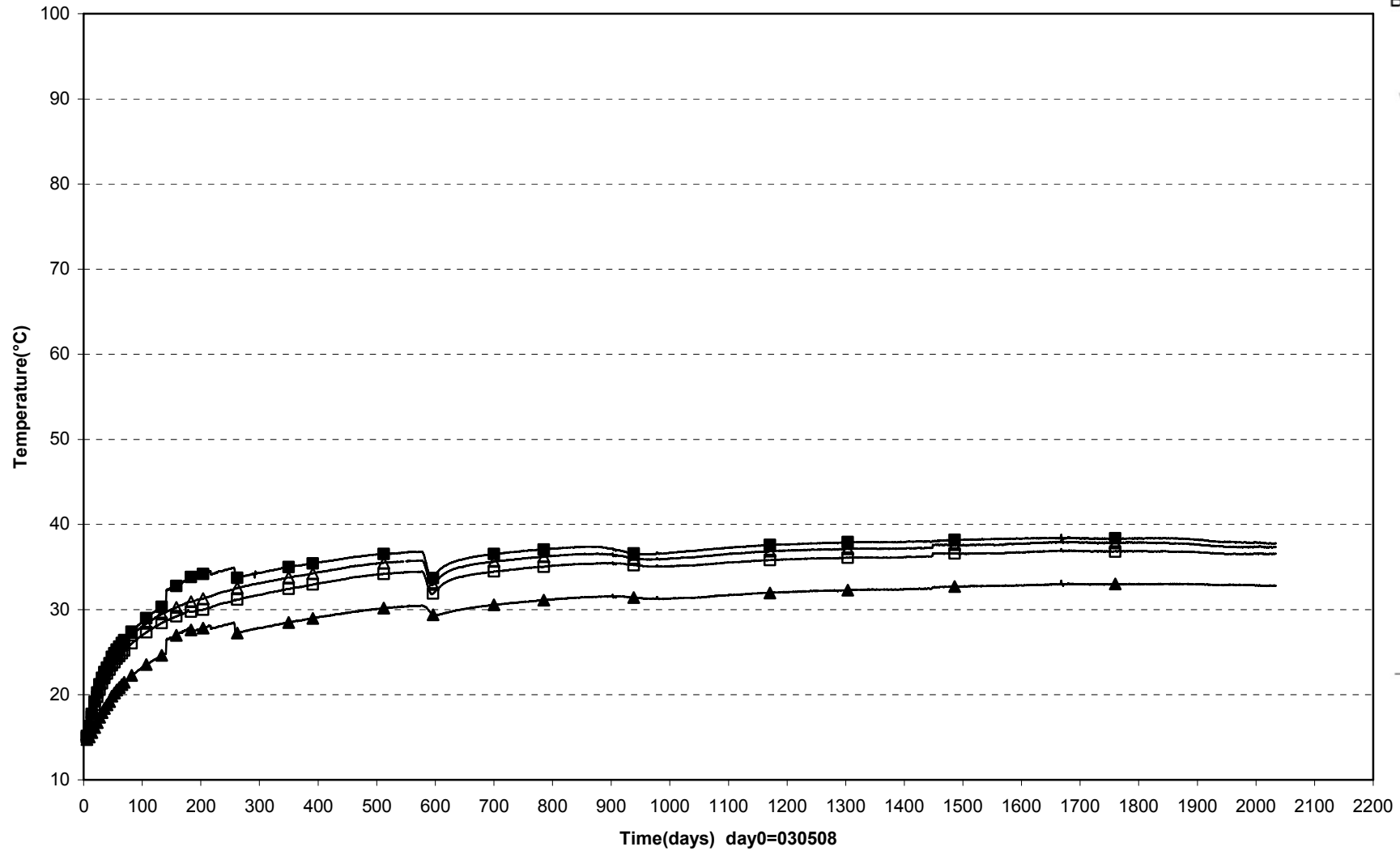

□ TB529(6.353\ 0°\0.785) △ TB530(6.353\ 95°\0.585) ■ TB531(6.353\ 185°\0.585) ▲ TB532(7.060\ 0°\0.785)

Prototype\Hole 5\Cyl.1 (030508-081201)
 Temperature - Geokon

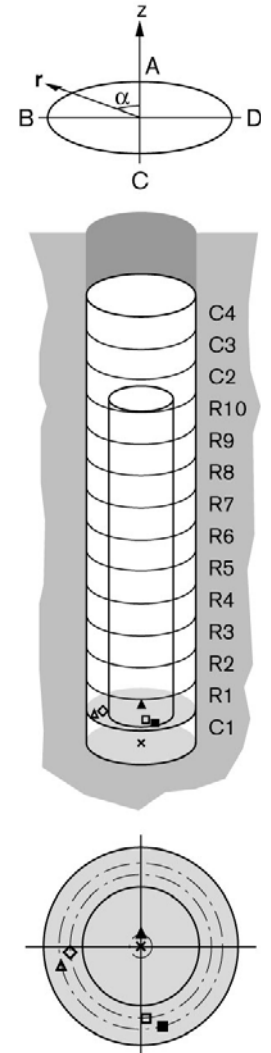
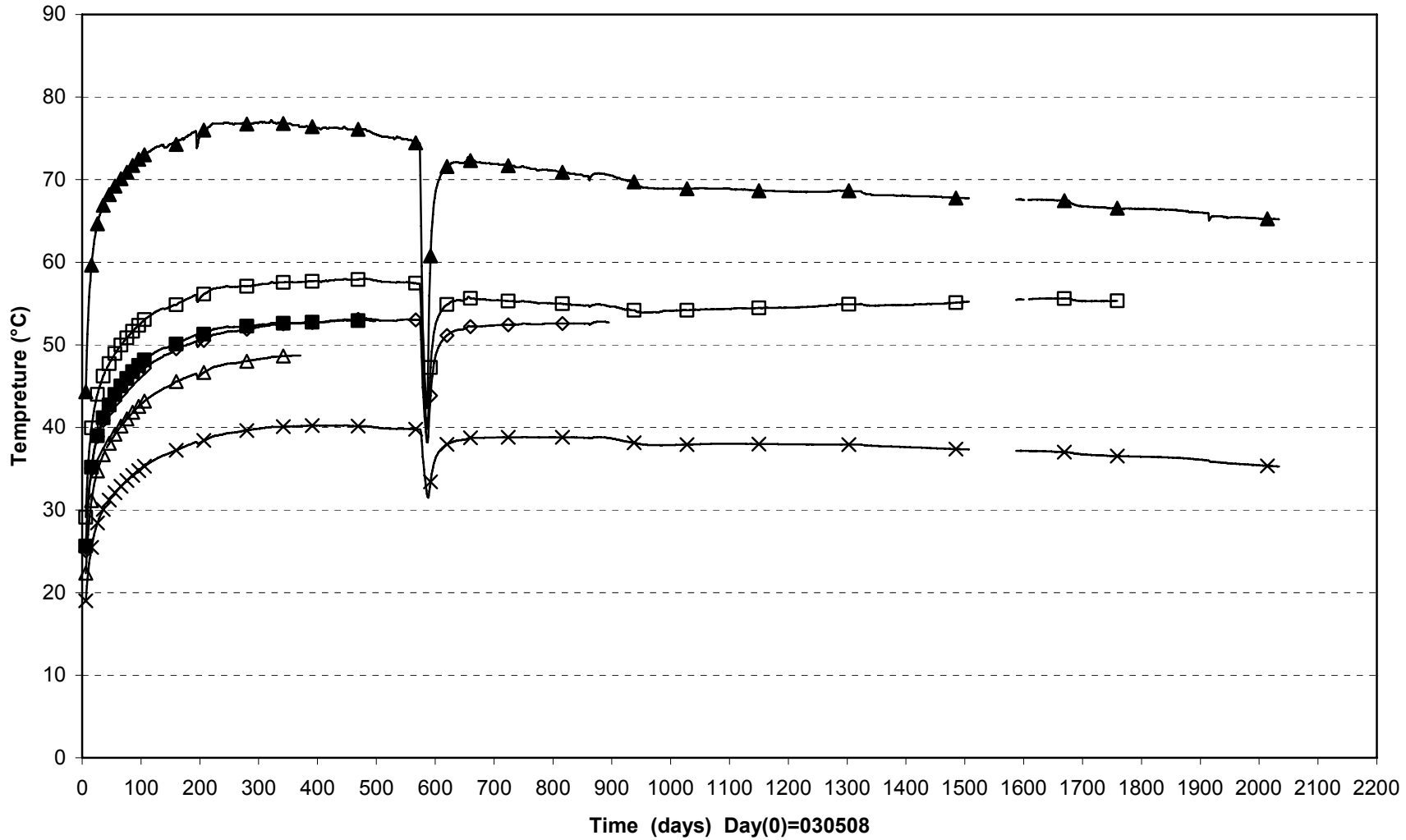

Prototype\Hole 5\Ring5 (030508-081201)
 Temperature - Geokon

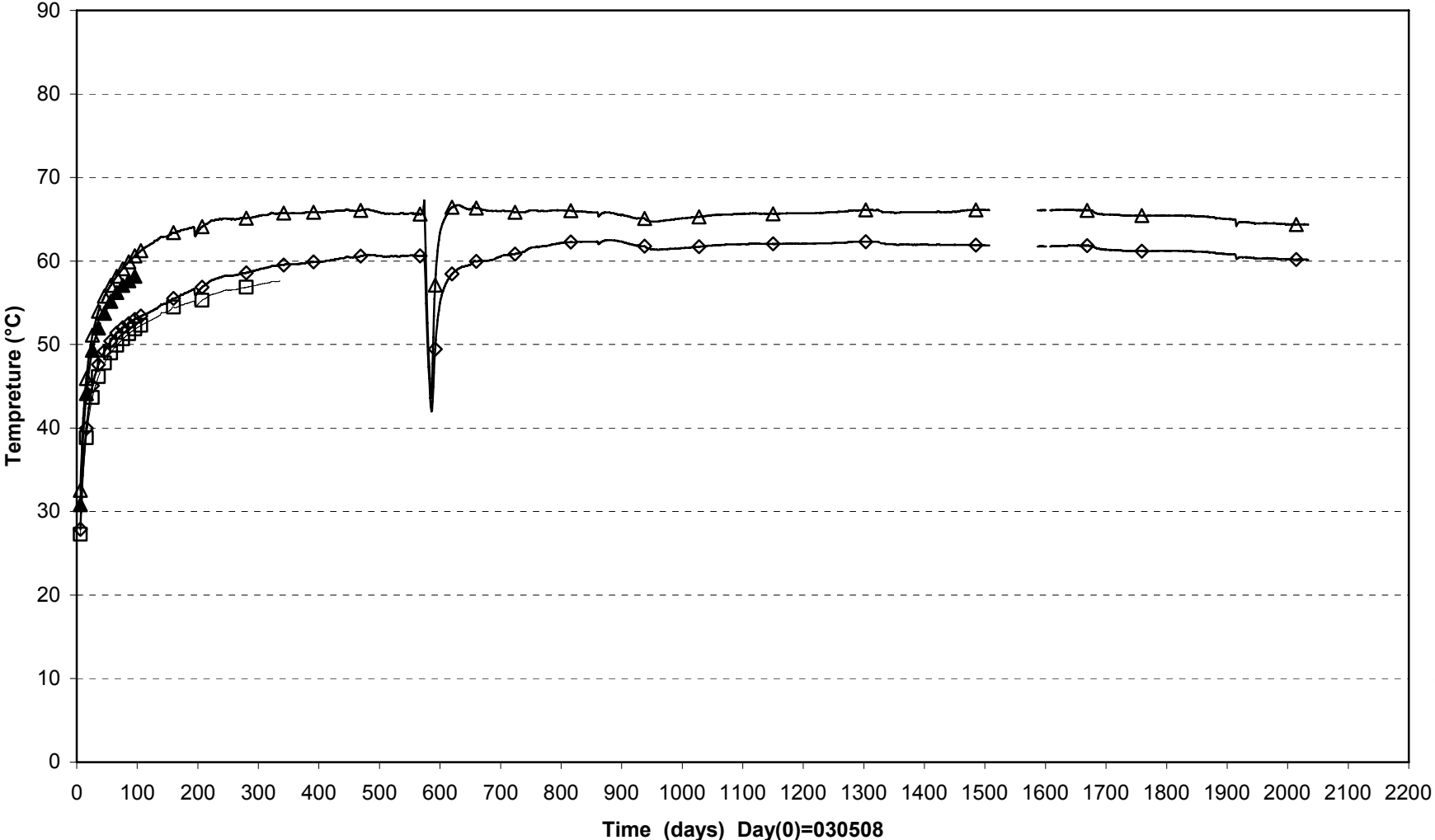

□ PB511T(3.036\5°\0.685)	▲ PB513T(3.036\95°\0.635)
◇ PB514T(3.036\95°\0.785)	△ PB515T(3.036\185°\0.635)

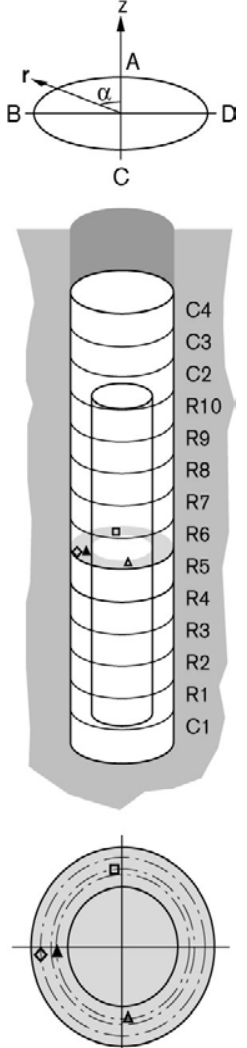

Prototype\Hole 5\Ring10 (030508-081201)
 Temperature - Geokon

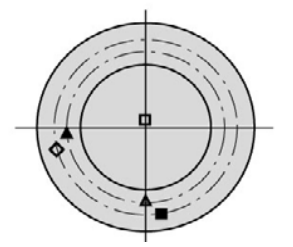
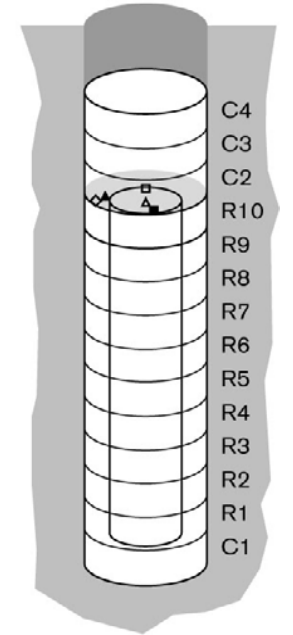
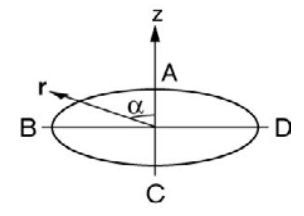
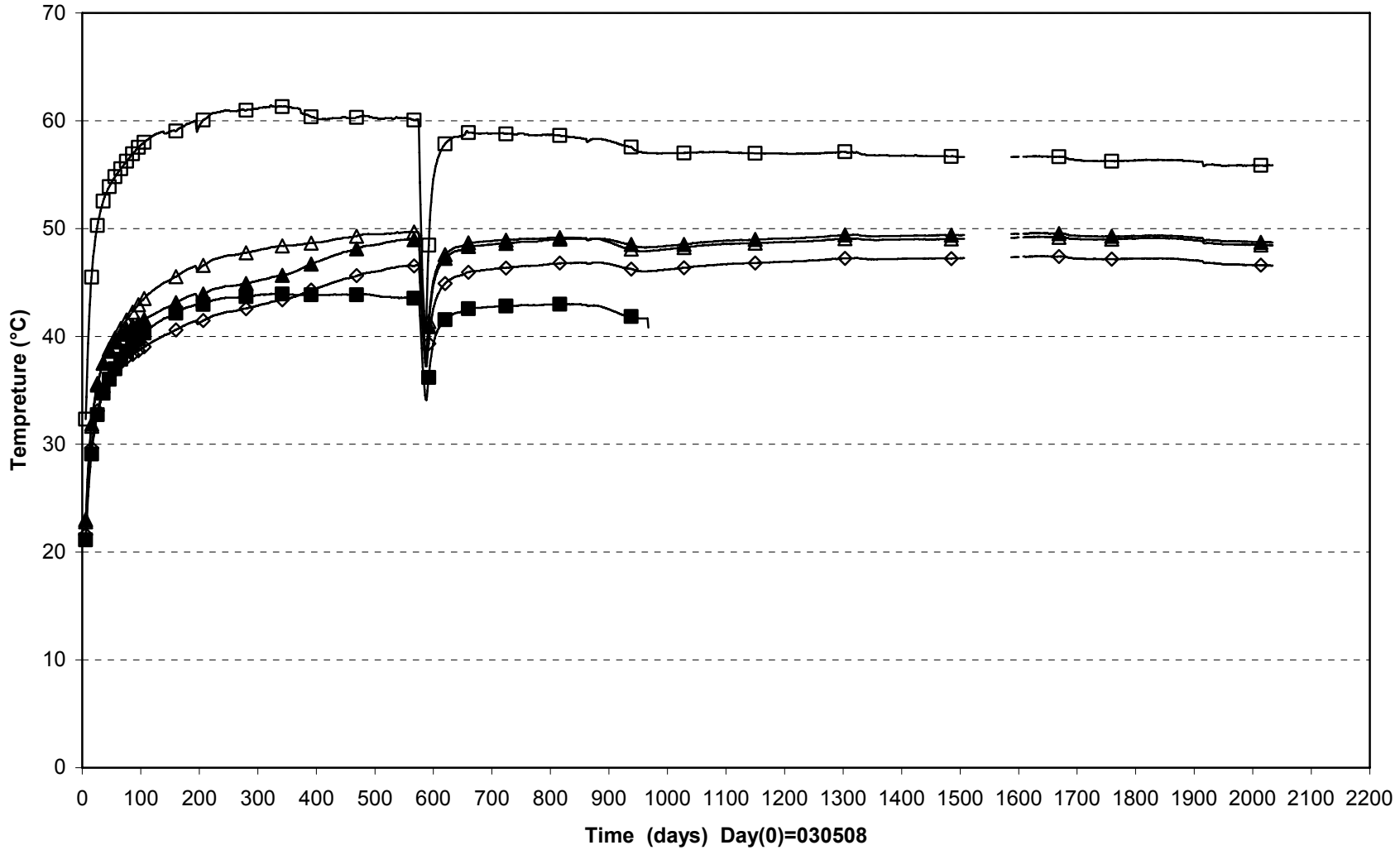

□ PB517T(5.593\0°\0.050)	▲ PB521T(5.593\95°\0.635)	◇ PB522T(5.593\105°\0.735)
△ PB523T(5.593\180°\0.635)	■ PB524T(5.593\190°\0.735)	

Prototype\Hole 5\Cyl.3 and Cyl.4 (030508-081201)
 Temperature - Geokon

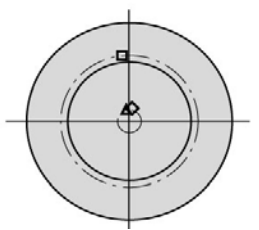
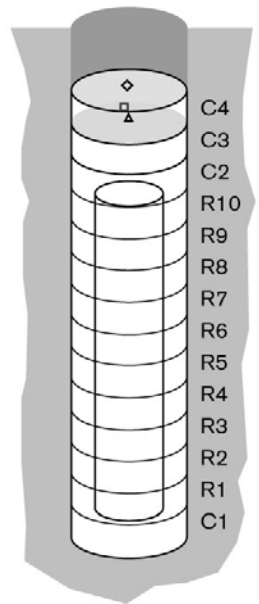
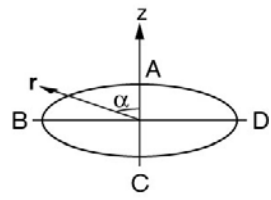
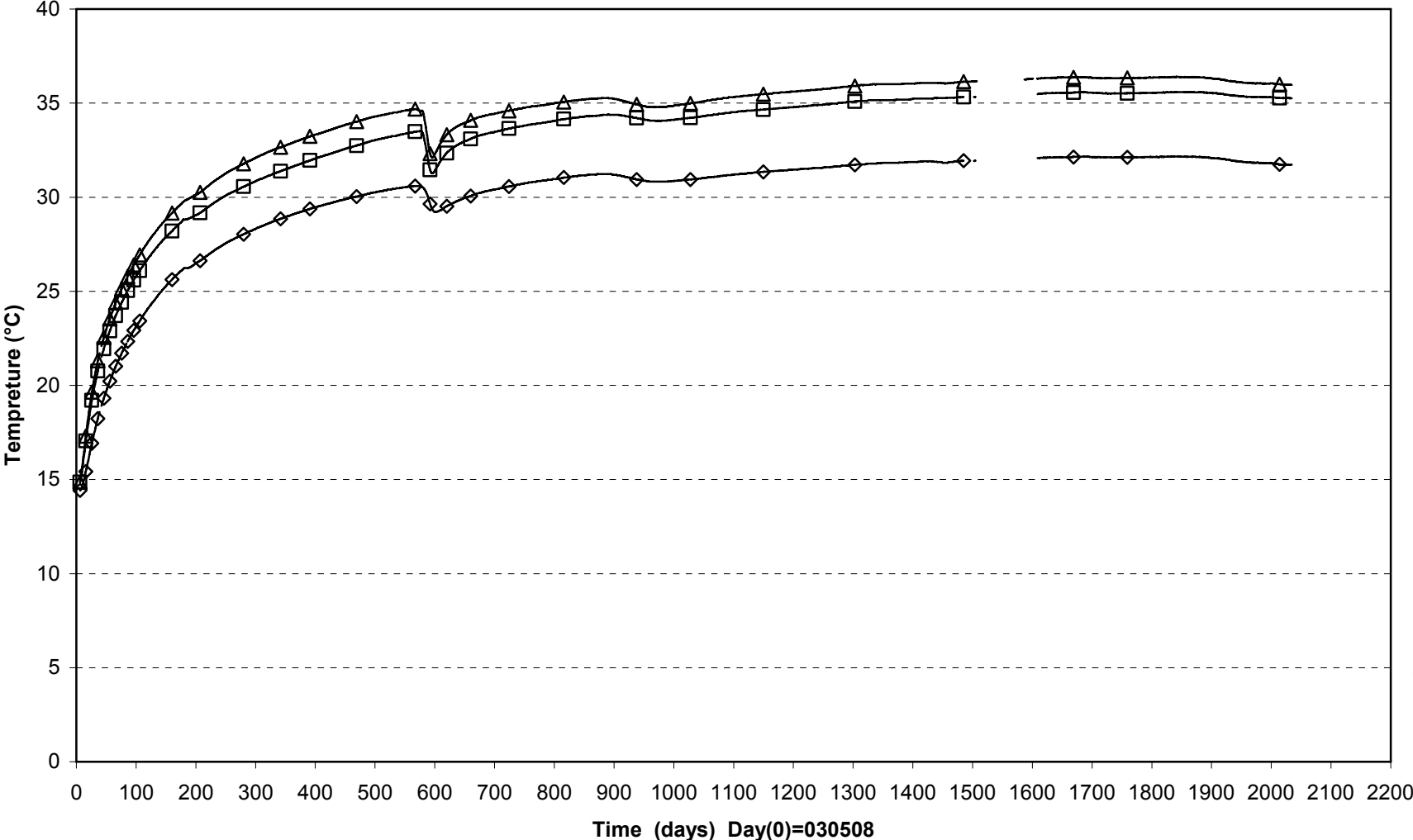

△PB525T(6.603\0°\0.100)
□PB526T(6.603\5°\0.585)
◇PB527T(7.110\0°\0.100)

Prototype\Hole5 (030508-081201)
Temperature - Geokon

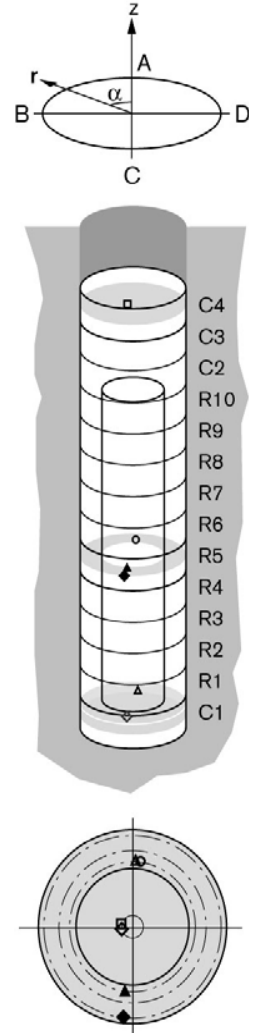
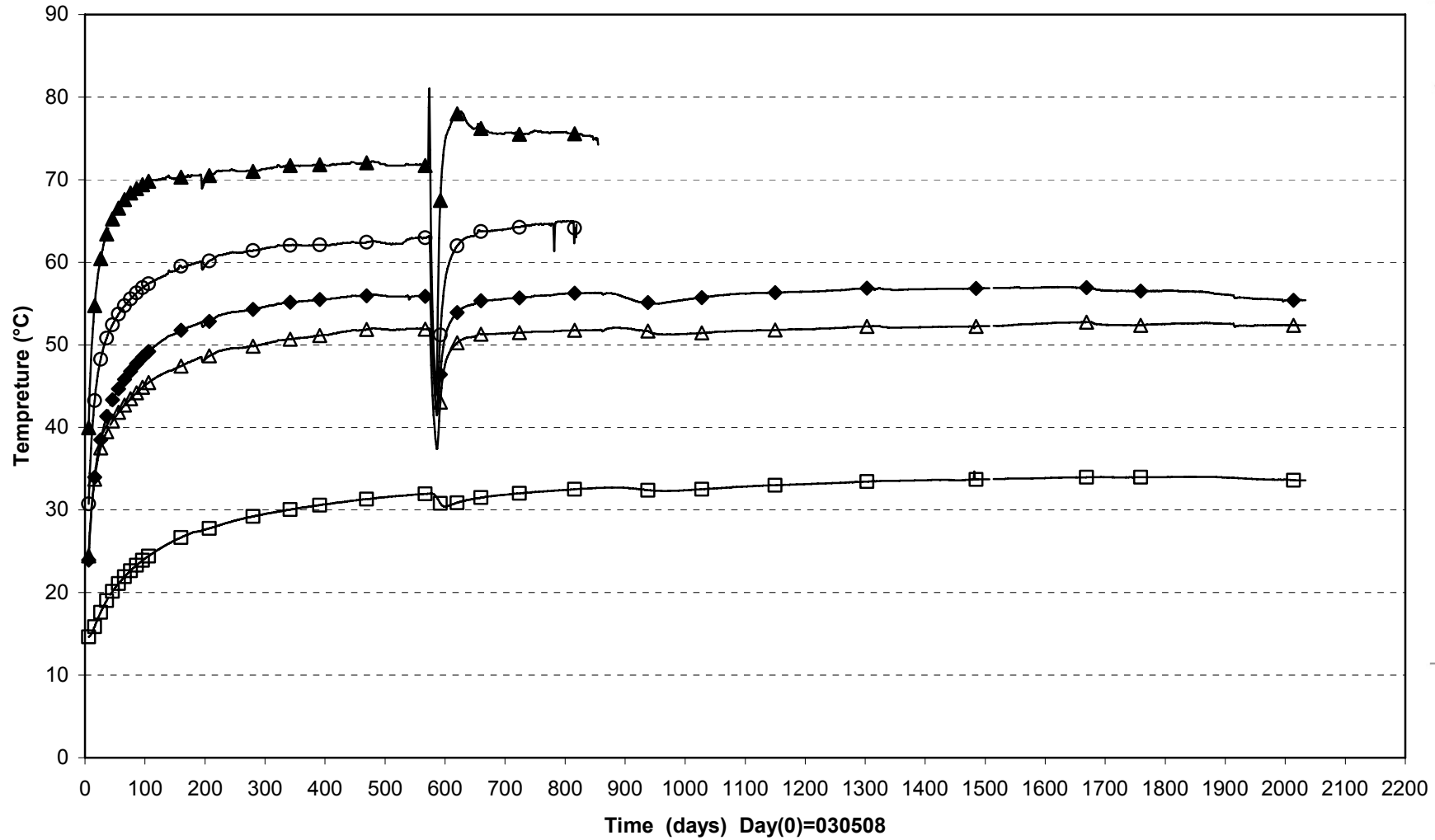

◇ UB502T(0.050\90°\0.100)	△ UB503T(0.250\355°\0.585)	○ UB505T(2.786\355°\0.585)
▲ UB509T(2.786\175°\0.535)	◆ UB510T(2.786\175°\0.825)	□ UB514T(6.860\90°\0.100)

Prototype\ Hole 5 \ Ring 3 (030508-081201)
 Temperature - Wescor

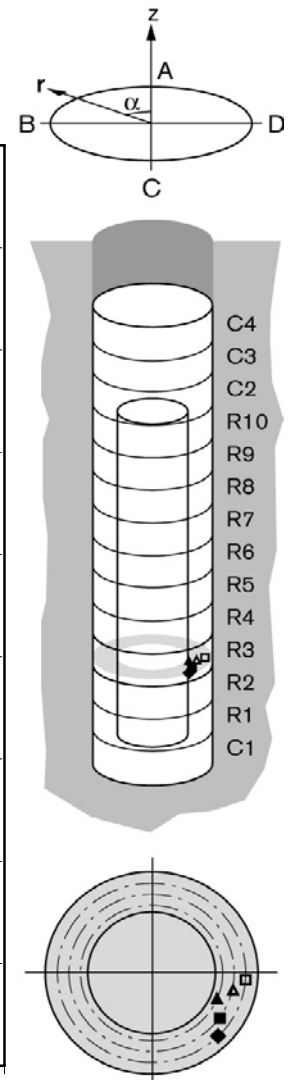
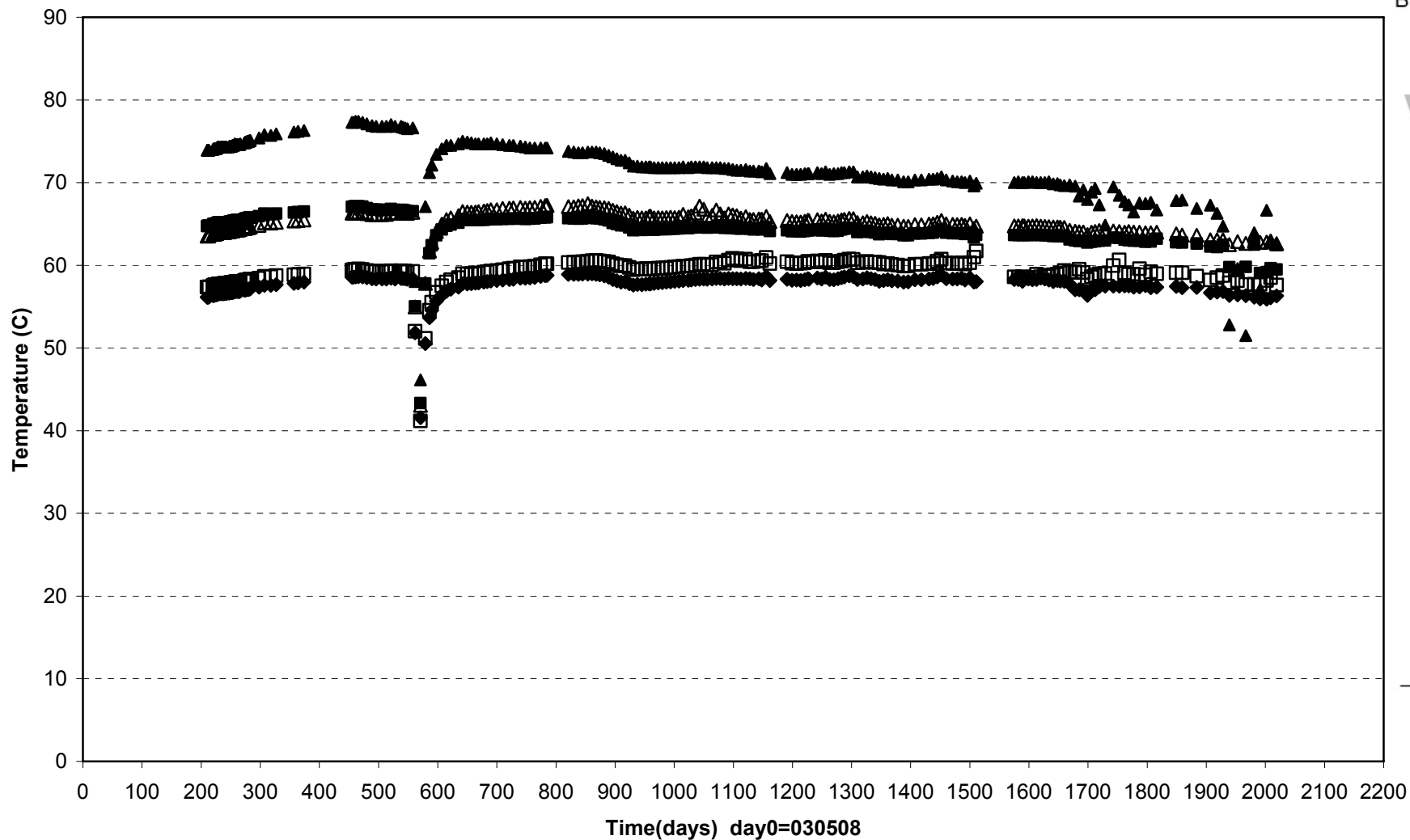

◆ WB538T(1.624\225°\0.775) ■ WB539T(1.624\235°\0.680) ▲ WB540T(1.624\245°\0.585) △ WB541T(1.624\255°\0.680) □ WB542T(1.624\265°\0.775)

Prototype\ Hole 5 \ Ring 8 (030508-081201)
 Temperature - Wescor

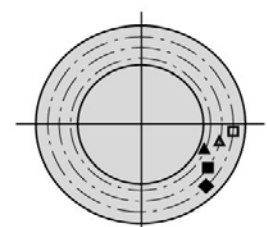
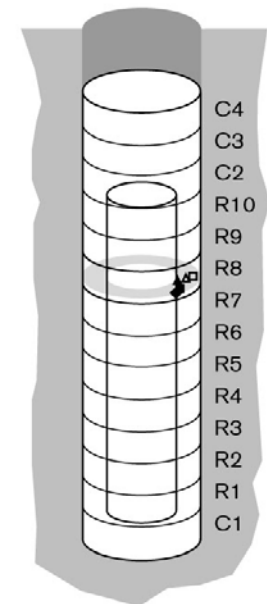
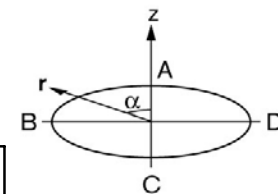
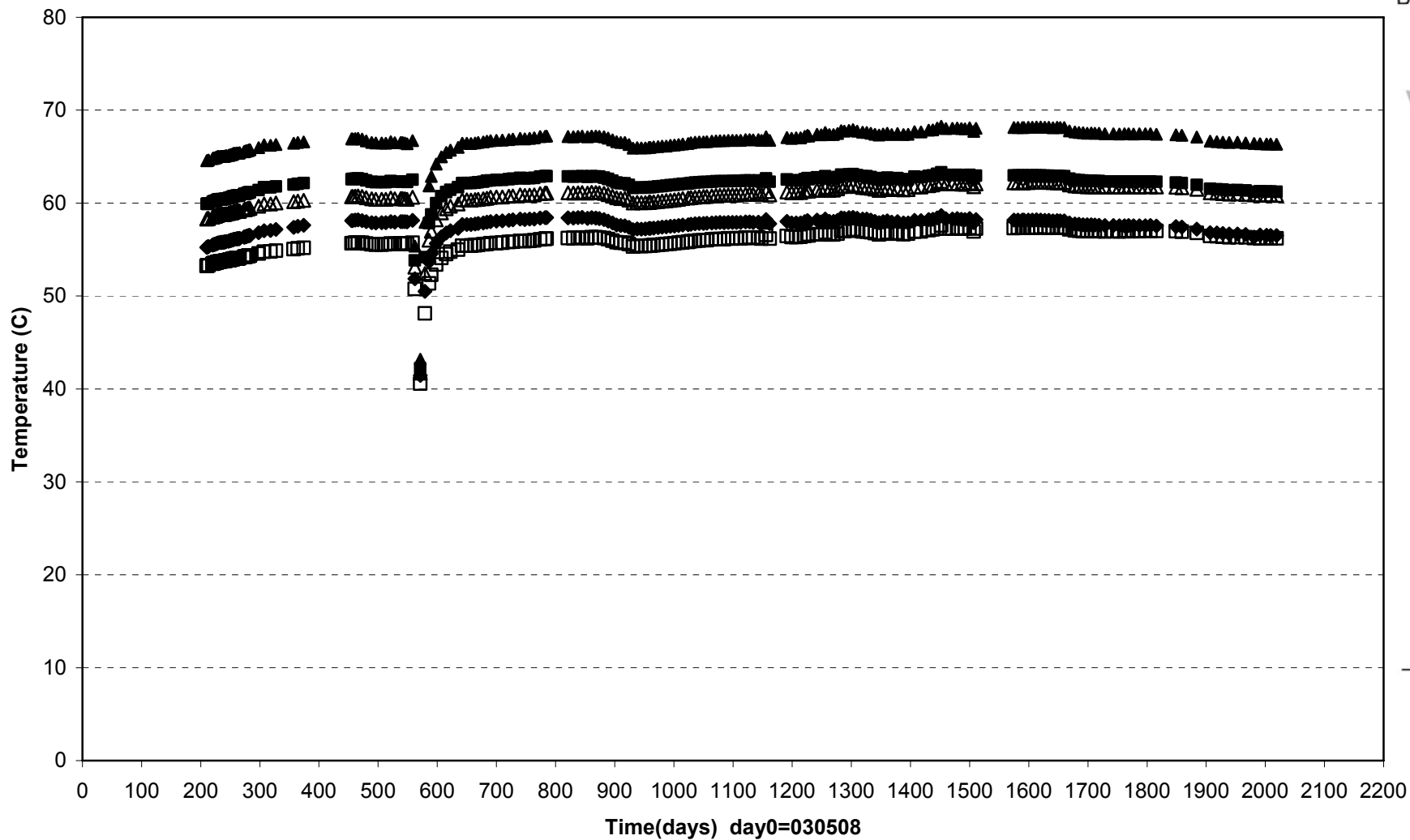

◆ WB543T(4.173\225°\0.775) ■ WB544T(4.173\235°\0.680) ▲ WB545T(4.173\245°\0.585) ▽ WB546T(4.173\255°\0.680) □ WB547T(4.173\265°\0.775)

Prototype\Rock\Hole 5\ Bottom (030508-081201)
 Temperature - Pentronic

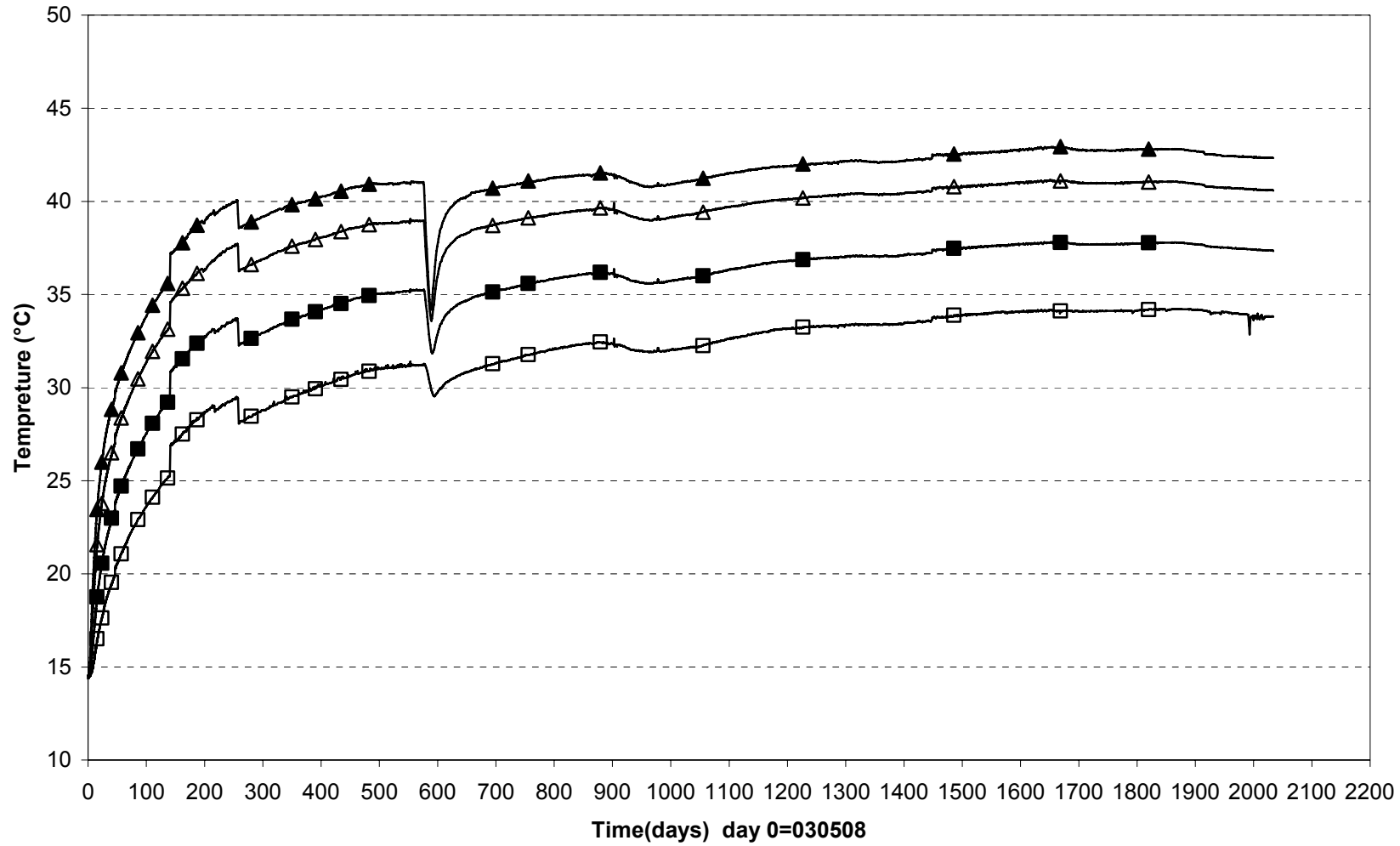

□ TR5011(-1,0°\0,0\Bottom) ■ TR5012(-0,5°\0,0\Bottom) △ TR5013(-0,2°\0,0\Bottom) ▲ TR5014(0,0°\0,0\Bottom)

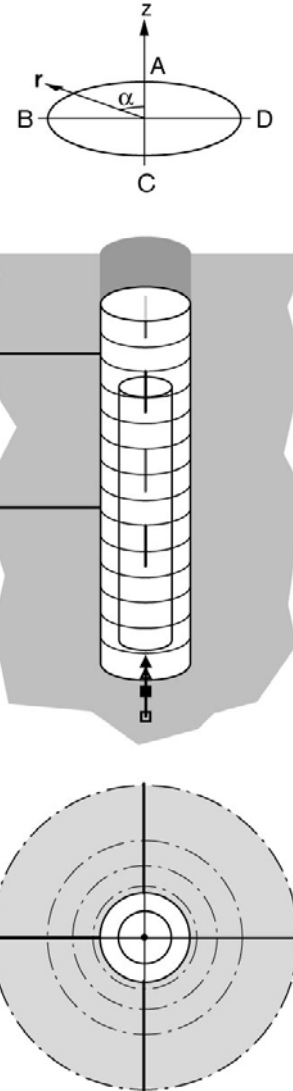

Prototype\Rock\Hole 5 \Level 3,0 m (030508-081201)
 Temperature - Pentronic

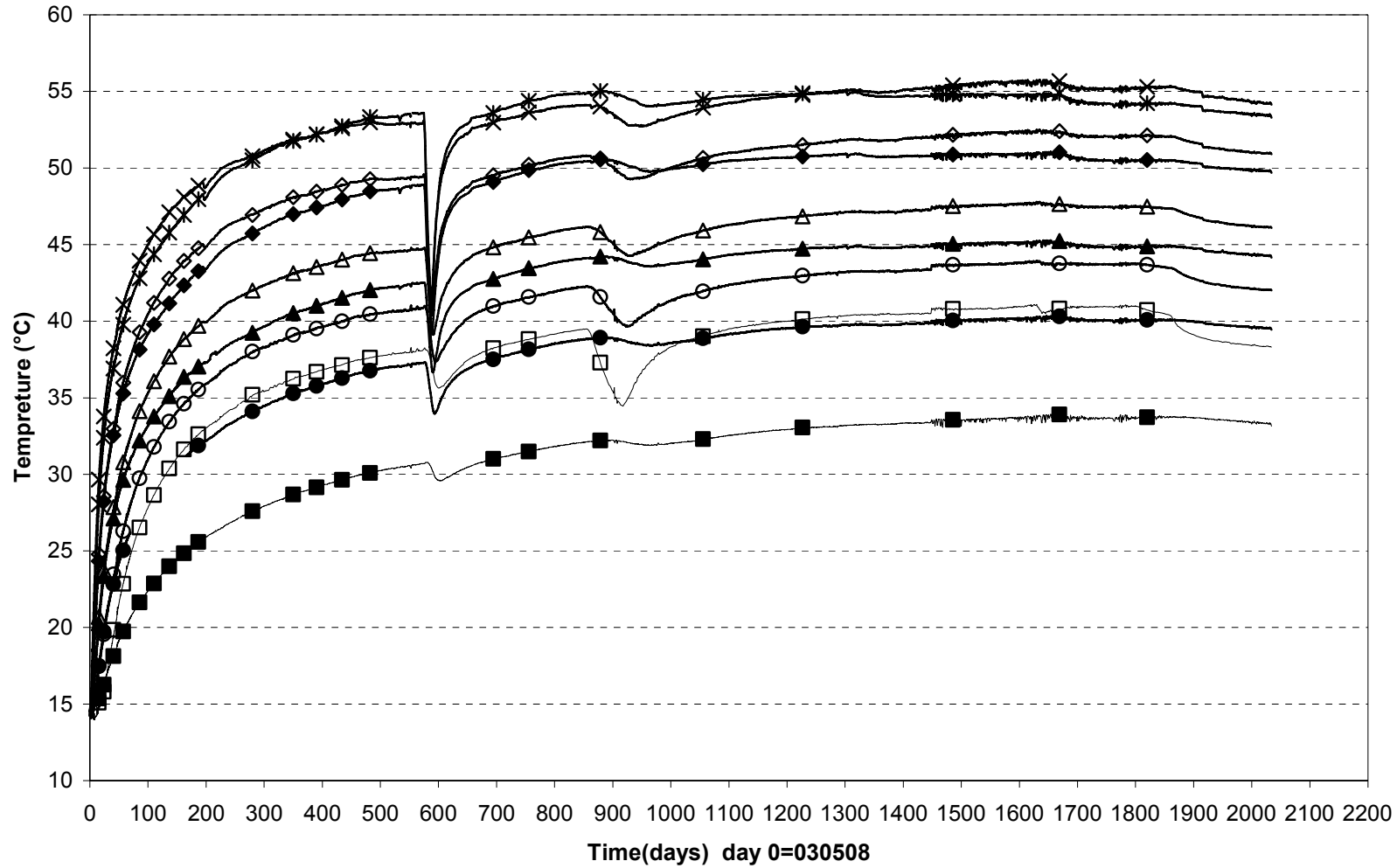

- TR5041 (3,0\170°\3,075) ○ TR5042 (3,0\170°\1,975) △ TR5043 (3,0\170°\1,475) ◇ TR5044 (3,0\170°\1,075) × TR5045 (3,0\170°\0,875)
- TR5051 (3,0\80°\3,075) ● TR5052 (3,0\80°\1,975) ▲ TR5053 (3,0\80°\1,475) ◆ TR5054 (3,0\80°\1,075) ✱ TR5055 (3,0\80°\0,875)

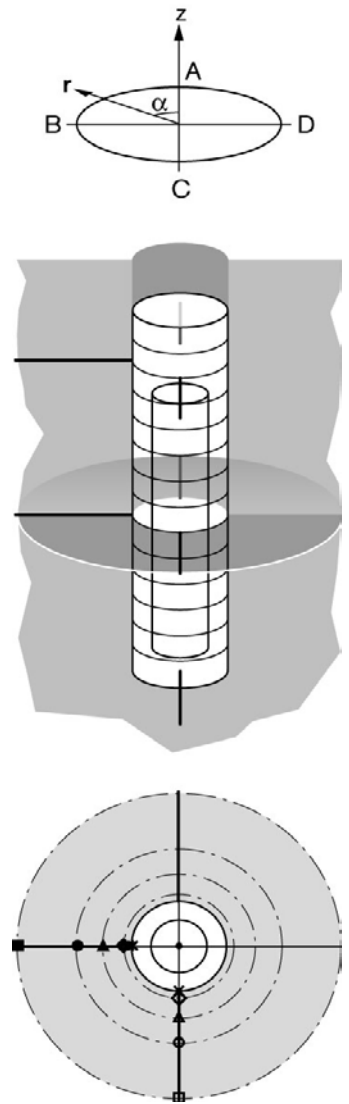

Prototype\Rock\Hole 5 \Level 6,0 m (030508-081201)
 Temperature - Pentronic

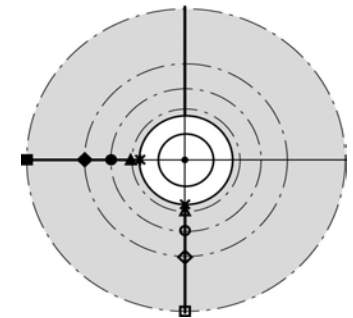
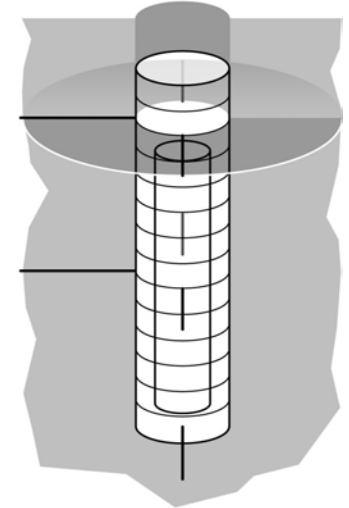
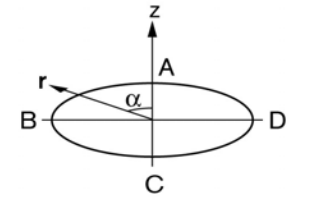
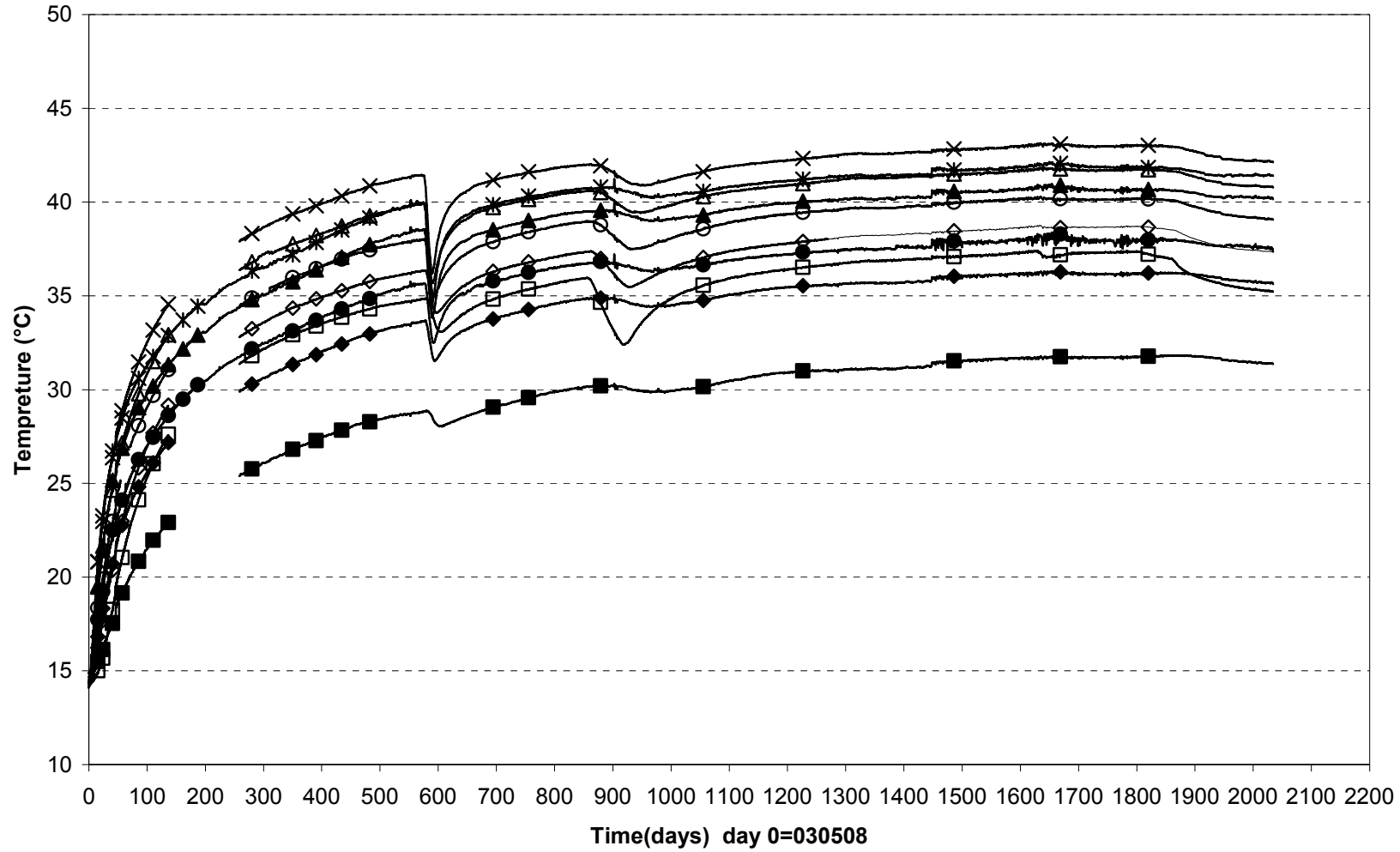

Prototype\Hole 5 (030508-081201)
Canister power

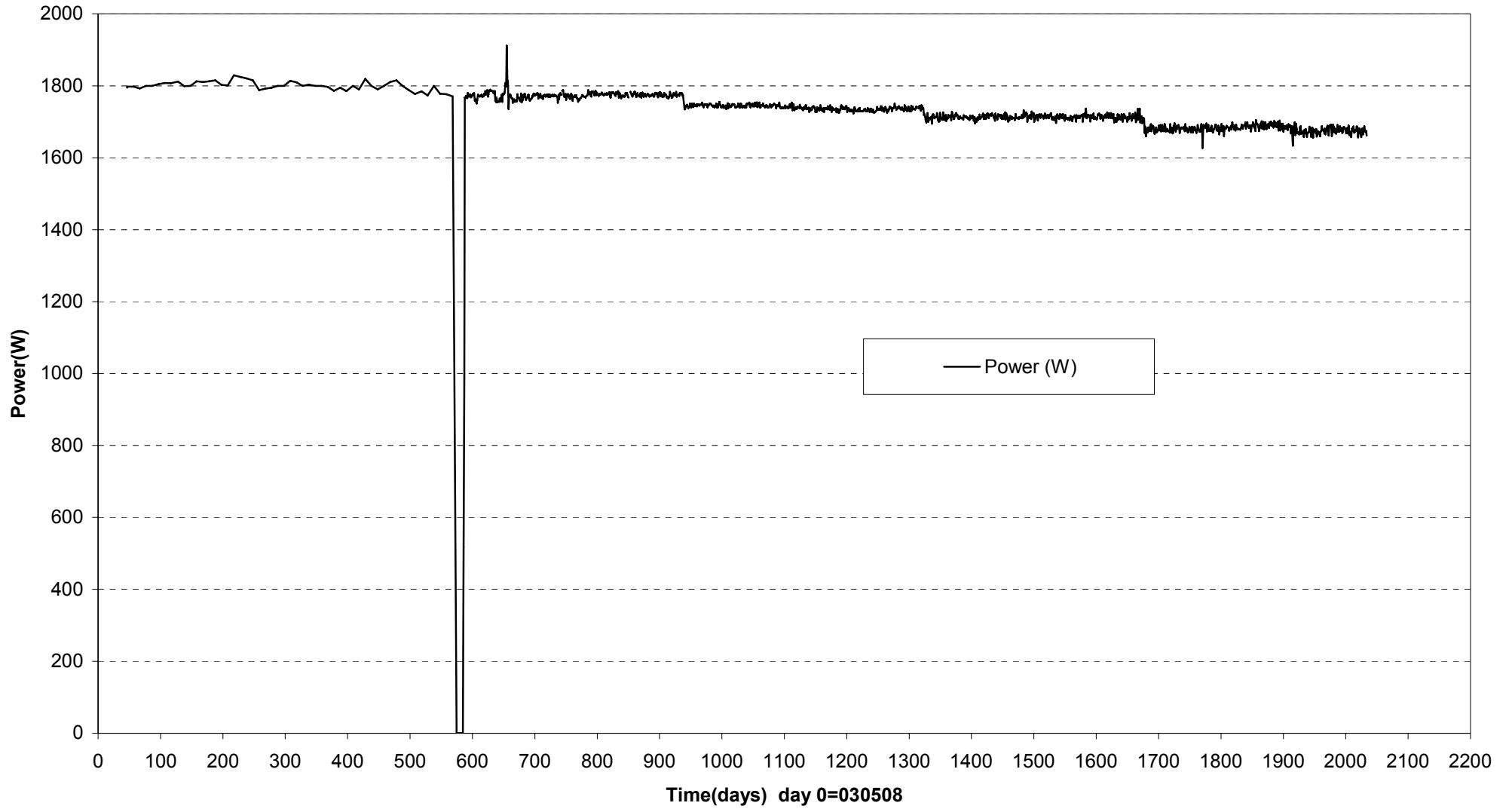

Prototype\ Hole 5 \Canister (030508-070601)
 Max. temperature on the canister surface - Optical fiber cables

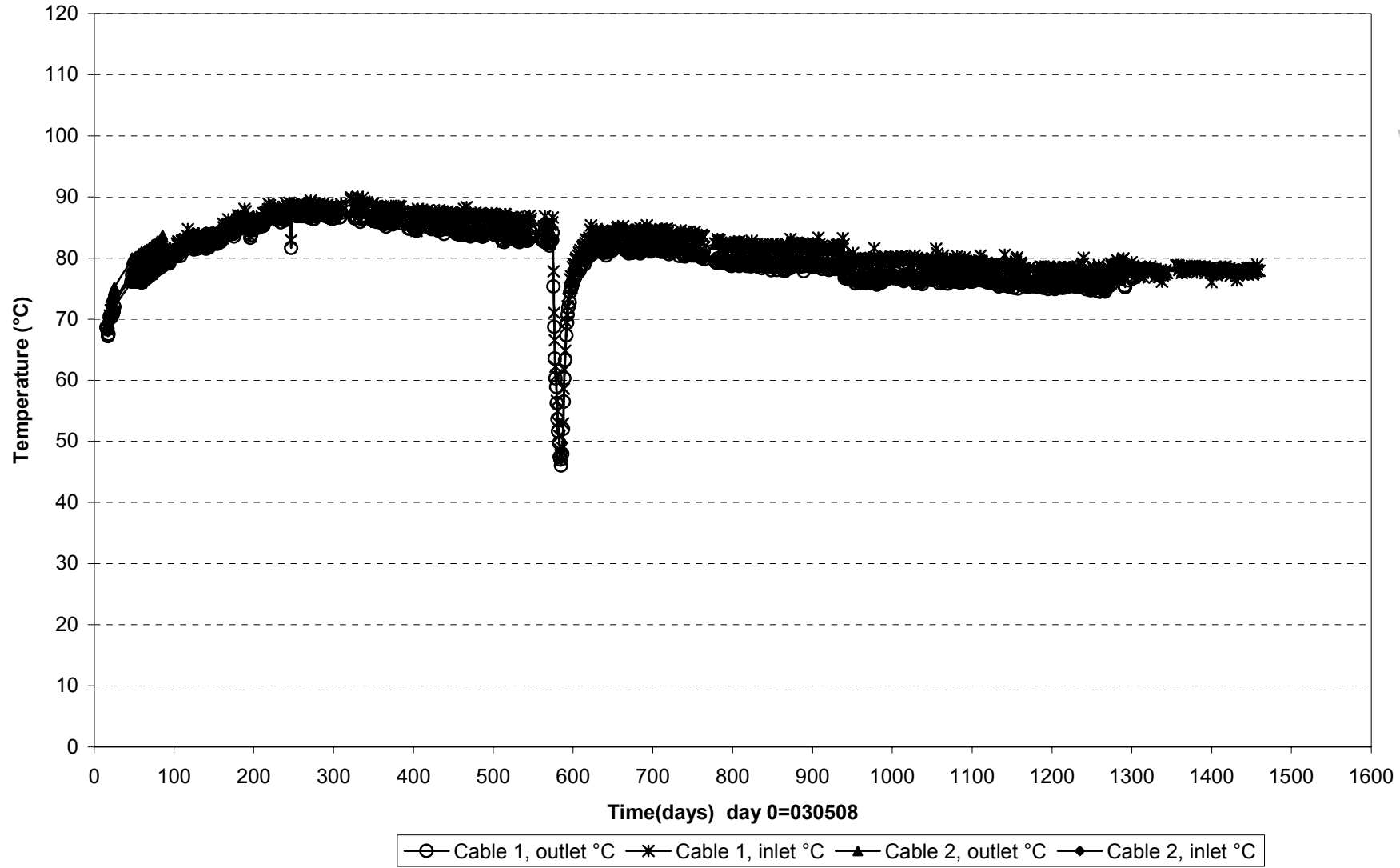

Temperature profile on the canister surface-No5 (061201)
Optical fiber cables

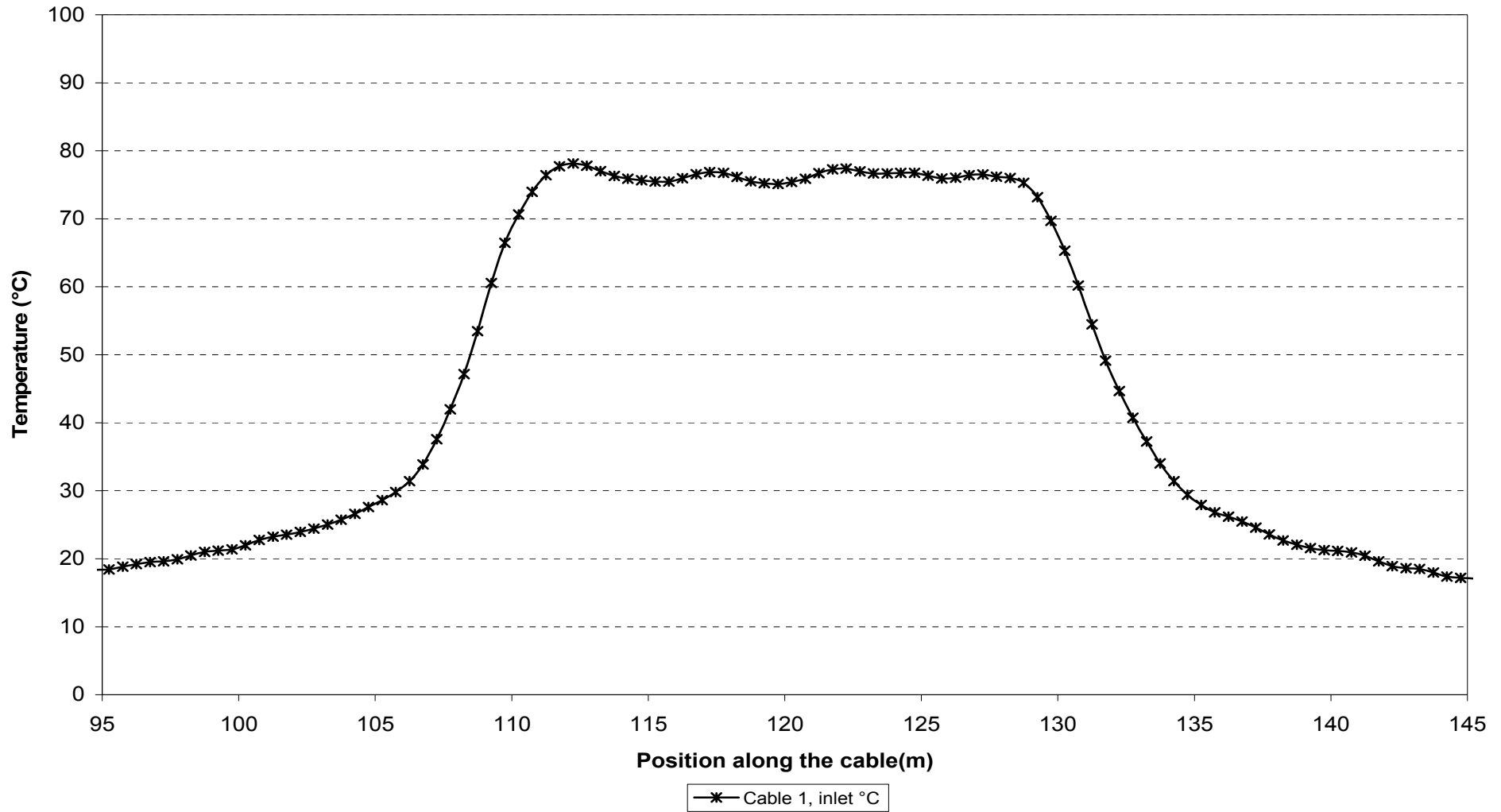

Prototype\Hole 5 \On the canister surface (030508-081201)
 Temperature - Pentronic

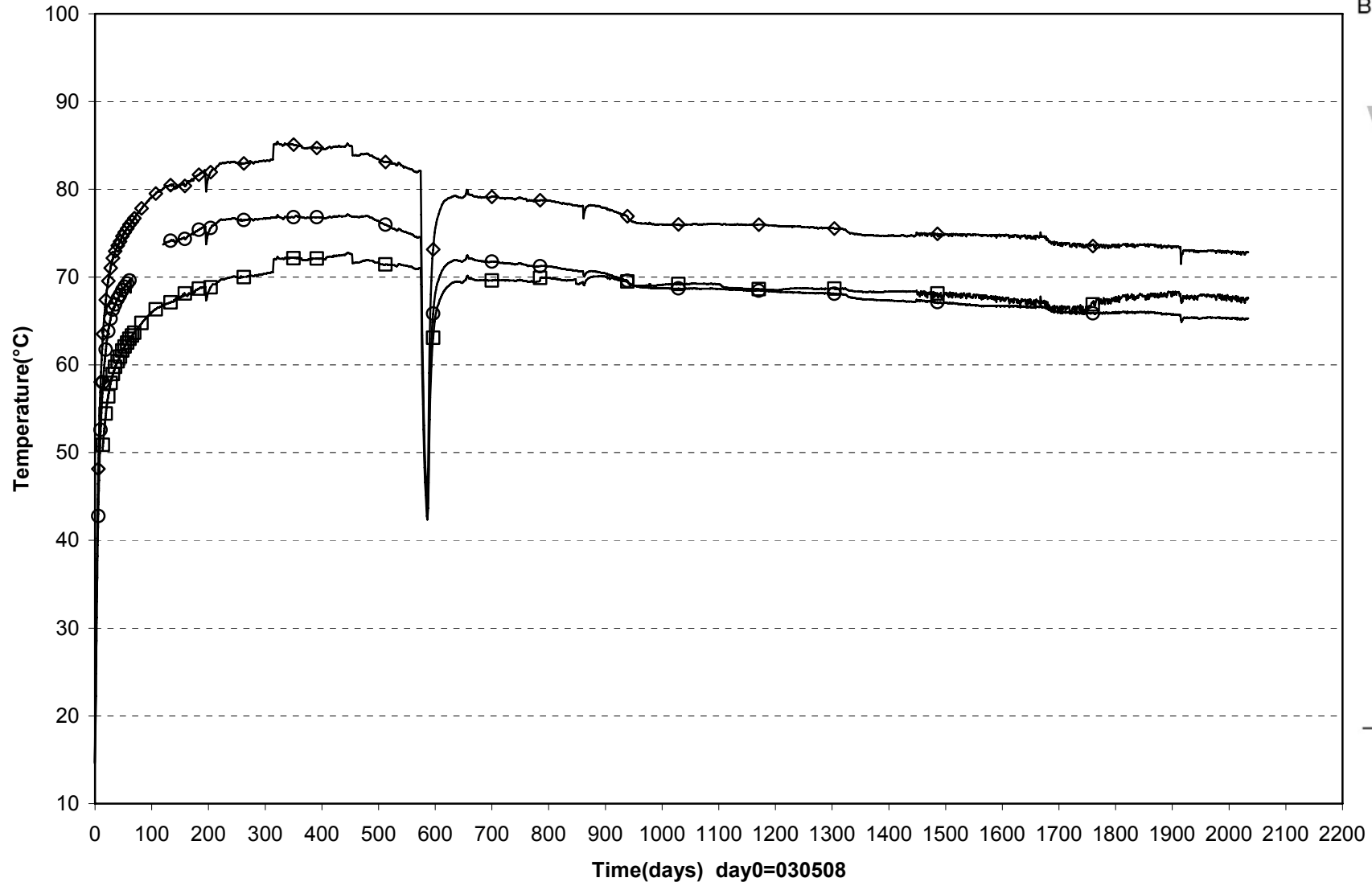

□ TB504(0.450\355°\0.525) ◇ TB511(2.950\0°\0.525) ○ TB524(5.150\ 0°\0.525)

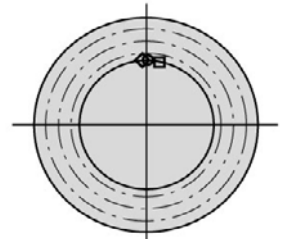
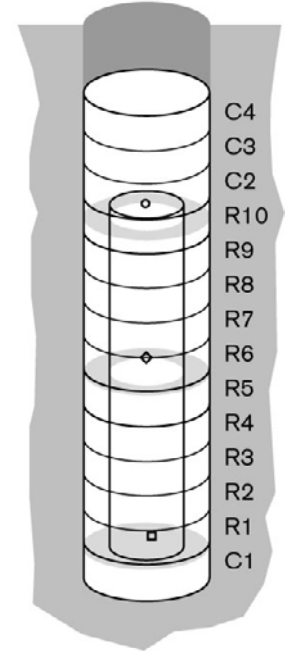
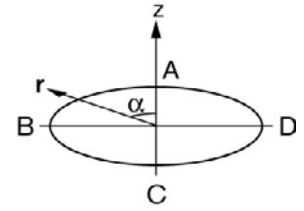

Appendix 6

Dep. hole 6

Prototype\Hole 6\Cyl.1 , Cyl.2 and Cyl.3 (030508-081201)
 Total pressure

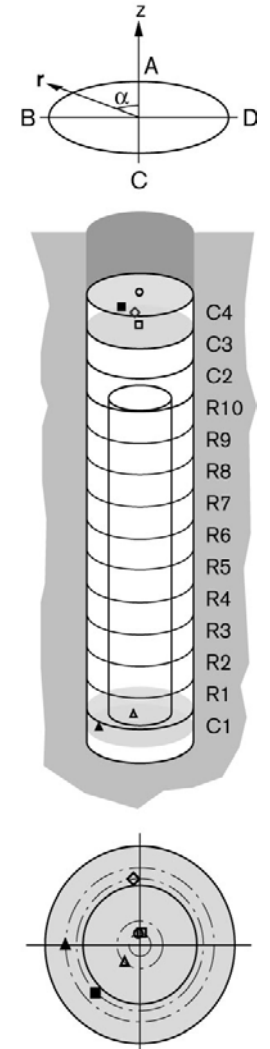
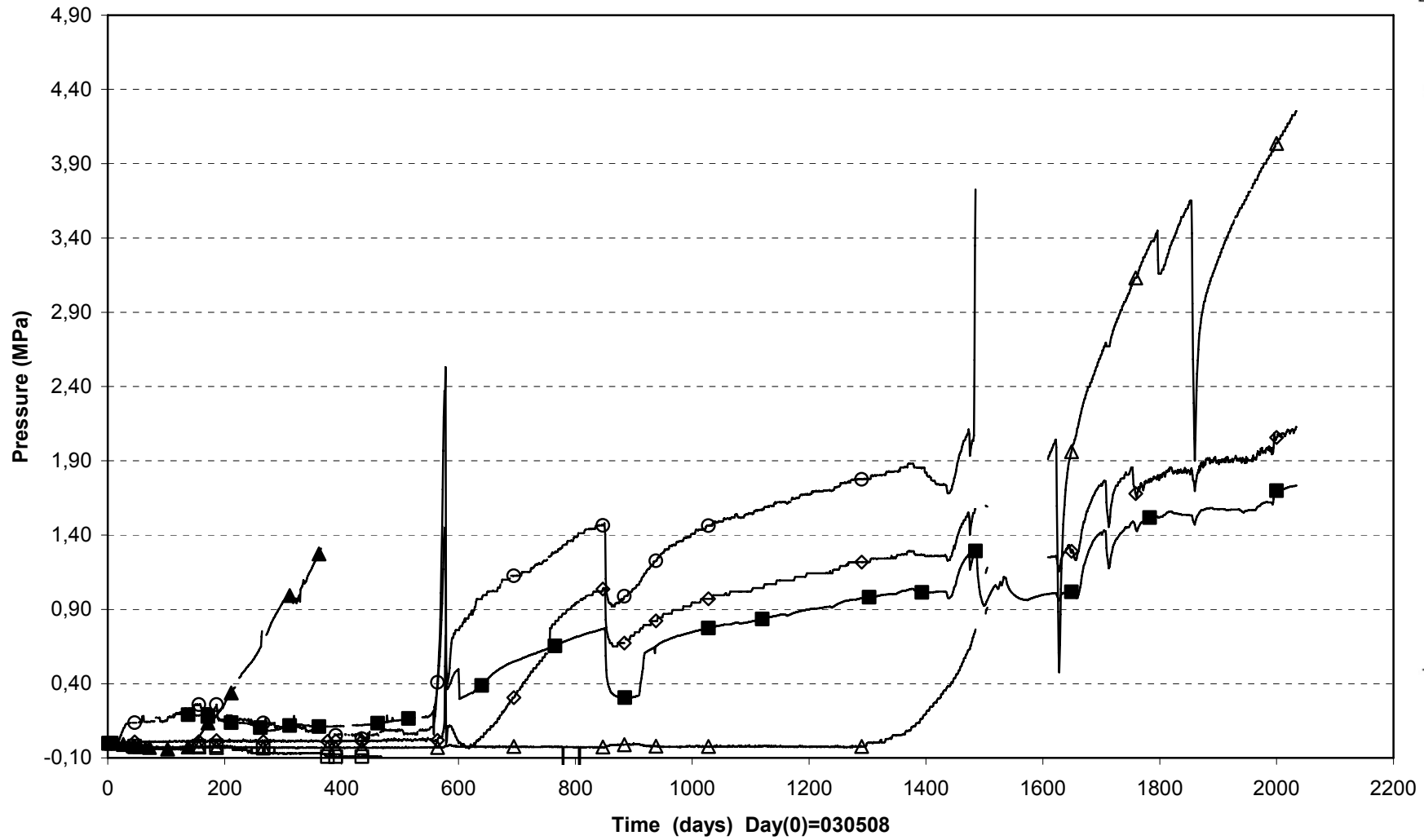

△ PB601(0.510\315°\0.210)	▲ PB602(0.260 \80°\ 0.685)	■ PB624(7.121 \135°\ 0.585)
□ PB625(6.616\0°\0.100)	◇ PB626(6.616\5°\0.585)	○ PB627(7.121\0°\0.100)

PrototypelHole 6\ Ring1 and Ring 2 (030508-081201)
 Total pressure

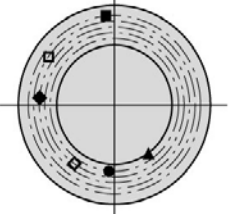
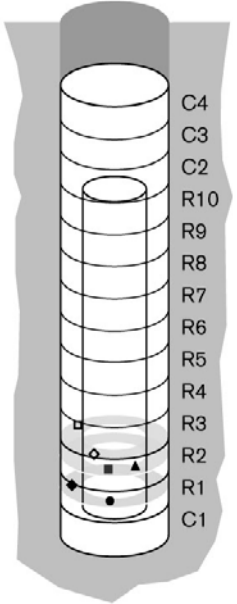
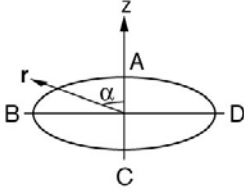
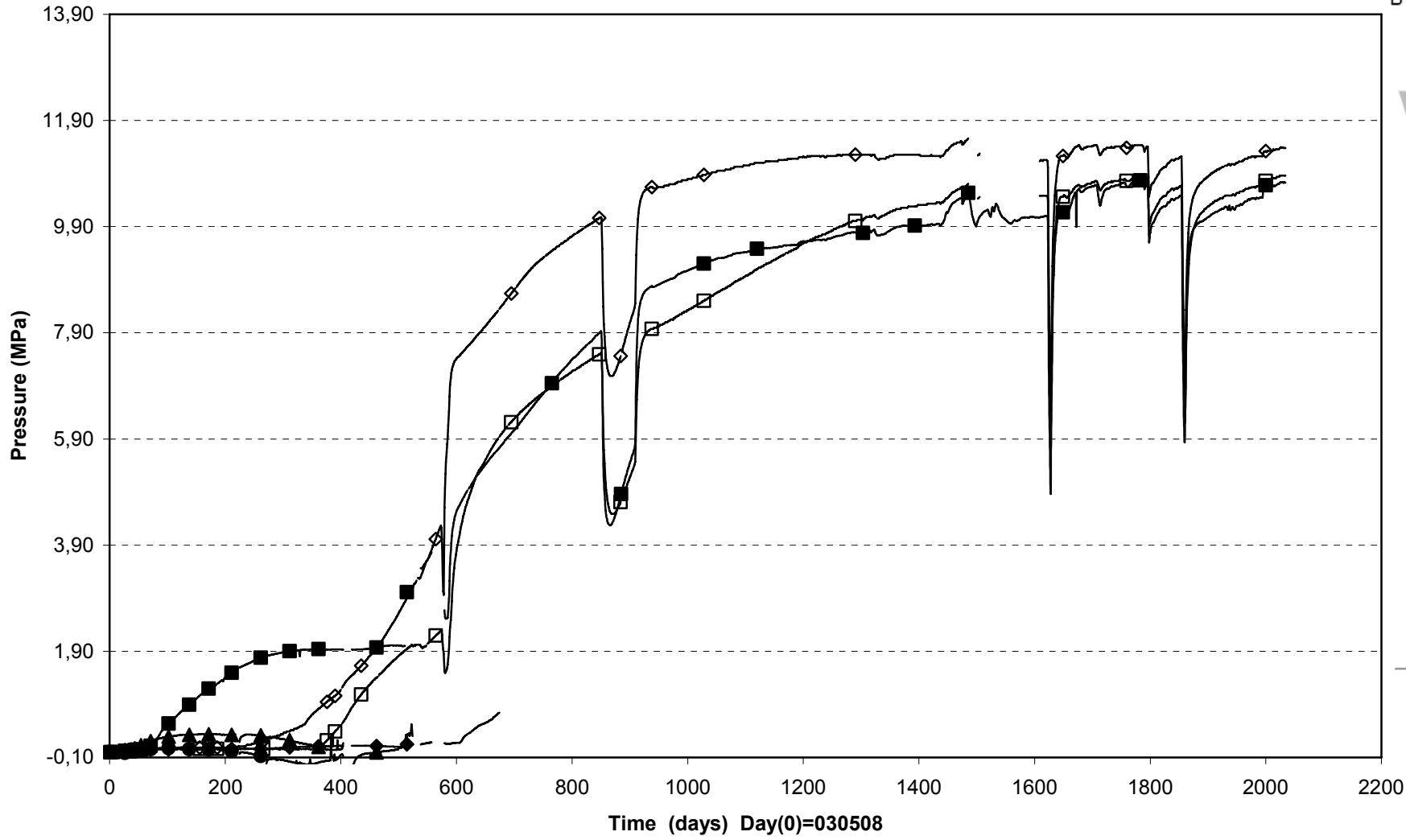

■ PB603(0.770 \10°\ 0.785)	◆ PB604(0.770 \80°\ 0.685)	● PB605(0.770 \170°\ 0.585)
□ PB606(1.534\55°\0.735)	◇ PB607(1.534\145°\0.635)	▲ PB608(1.284 \215°\ 0.535)

Prototype\Hole 6\ Ring 5 and Ring 6 (030508-081201)
Total pressure

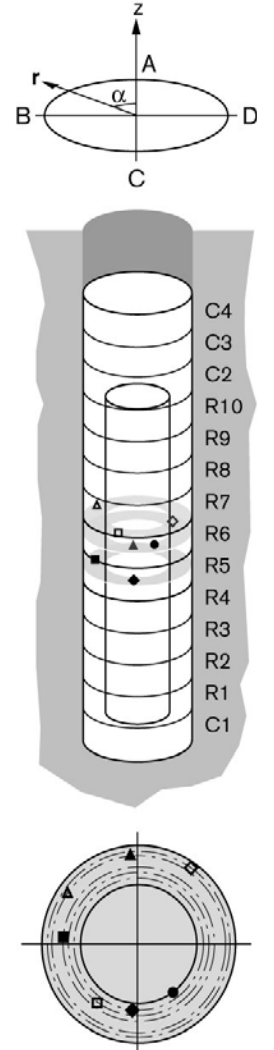
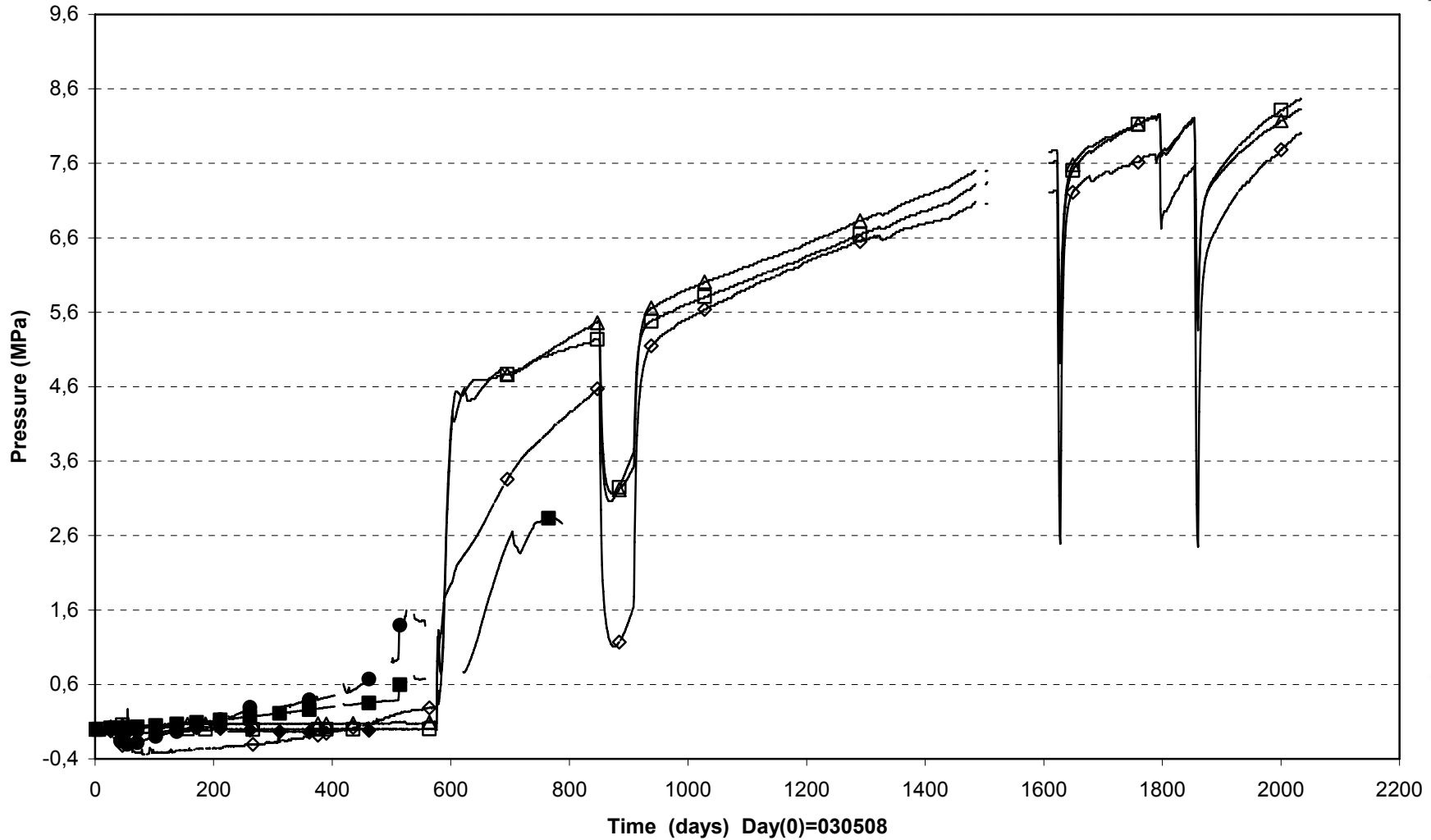

▲ PB610(2.795 \10°\ 0.785)	■ PB611(2.795 \80°\ 0.685)	◆ PB612(2.795 \170°\ 0.585)
△ PB613(3.550\55°\0.785)	□ PB614(3.550\145°\0.635)	● PB615(3.300 \215°\ 0.535)
◇ PB616(3.253\325°\0.875)		

Prototype\Hole 6\ Ring 8 and Ring 9 (030508-081201)
Total pressure

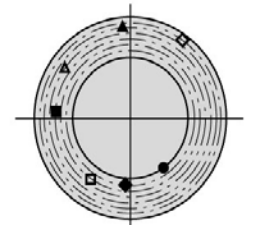
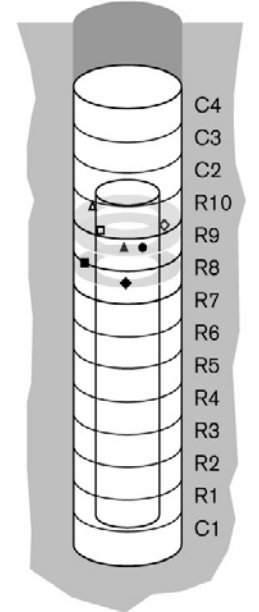
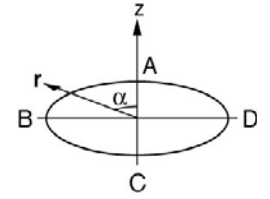
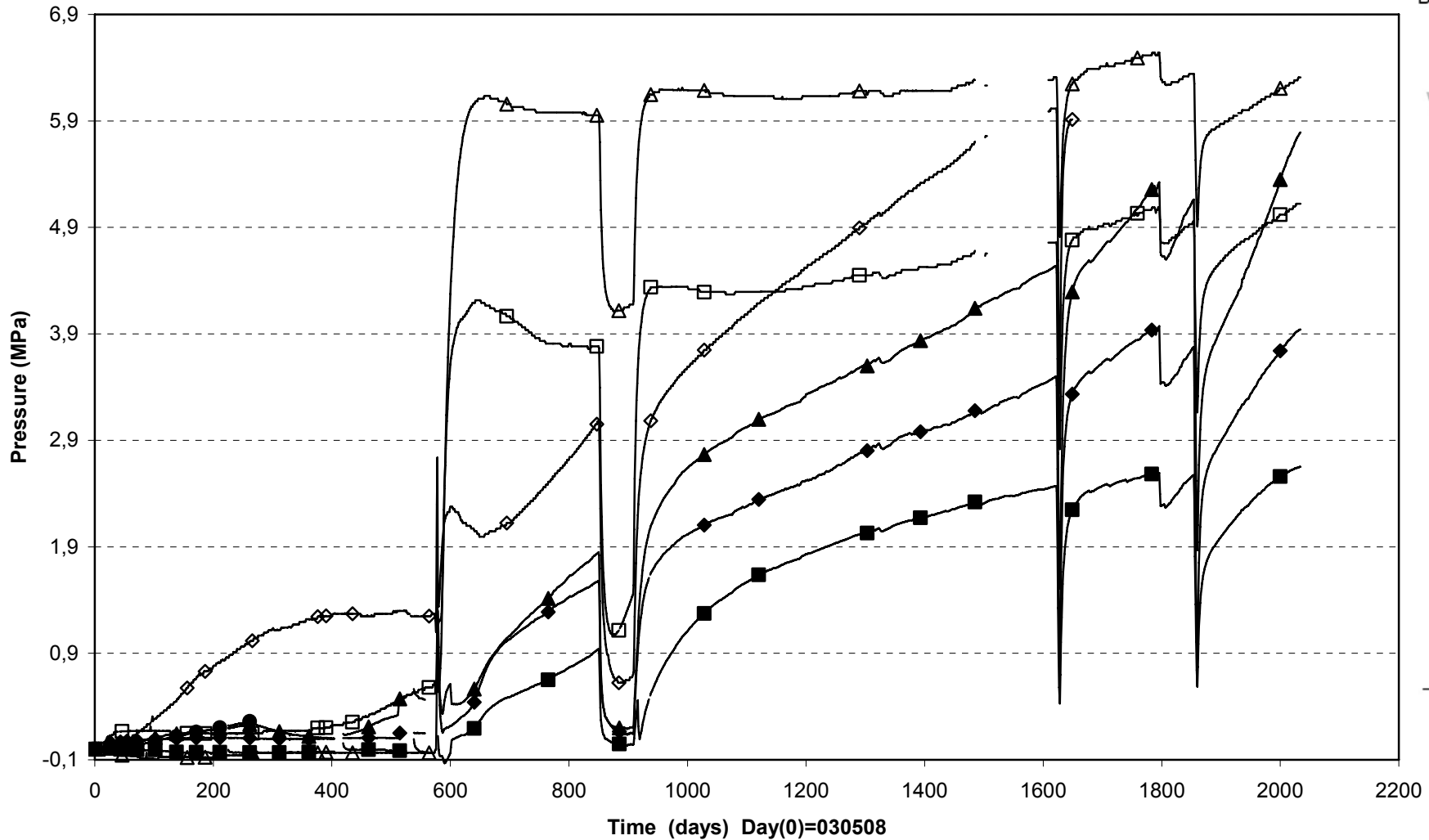

Prototyp\Hole 6\Cyl.1 (030508-081201)
 Relative humidity - Rotronic

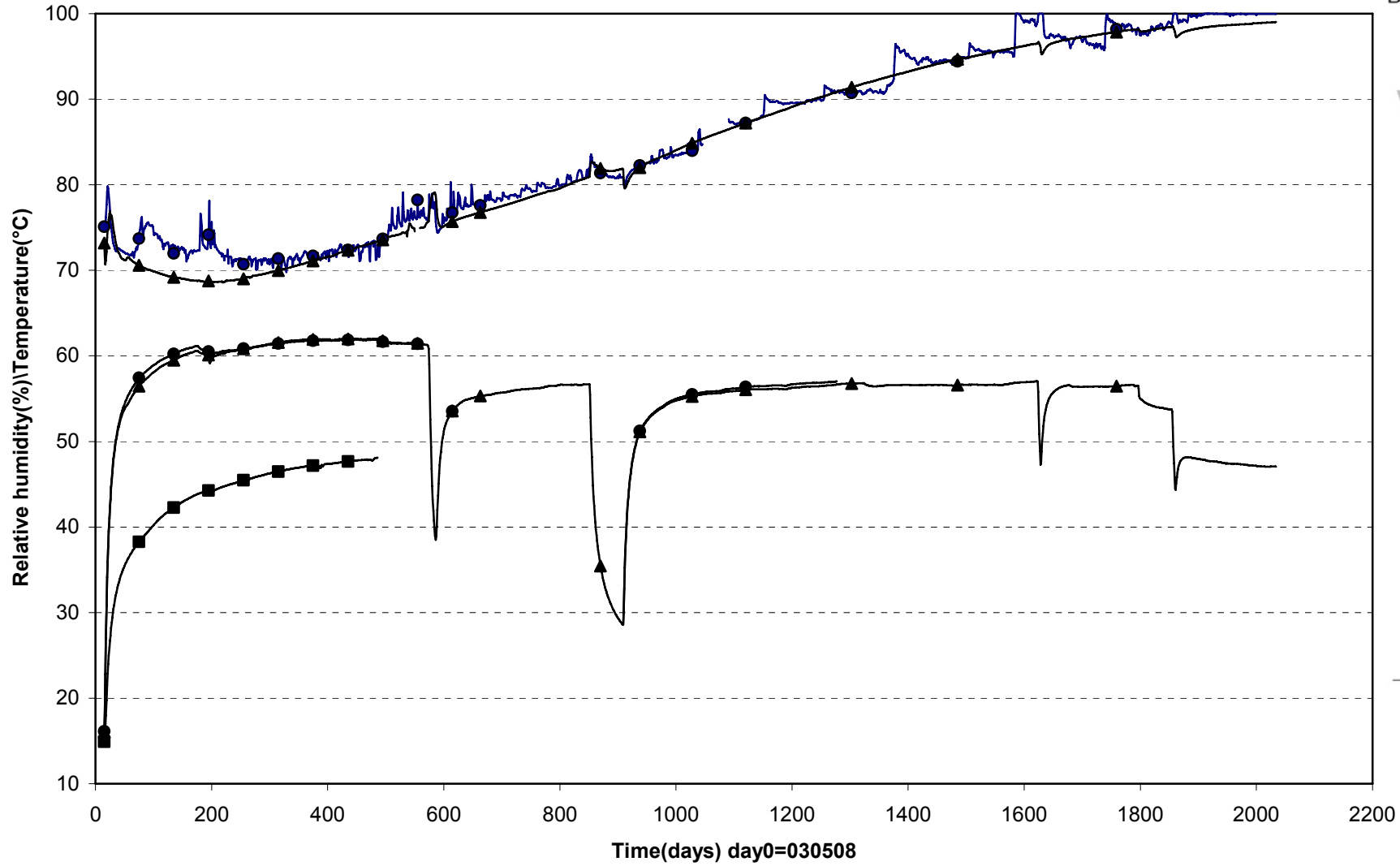

● WB601 (0.260\135°\0.050) ▲ WB604 (0.260\270°\0.210) ■ WB606 (0.260\100°\0.685)

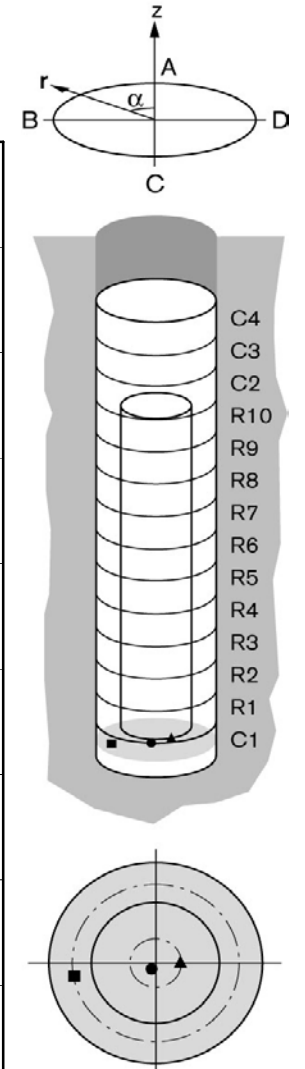

Prototype\Hole 6\ Ring 1 and Ring 2 (030508-081201)
Relative humidity

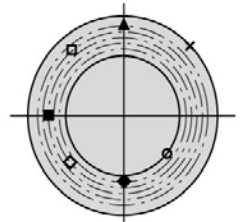
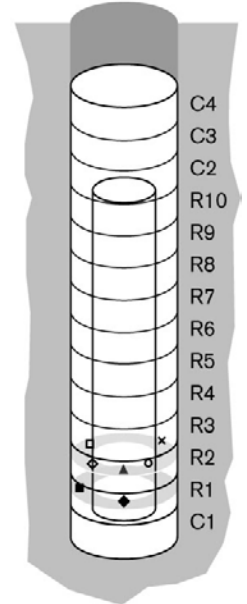
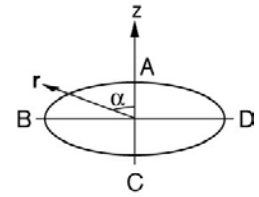
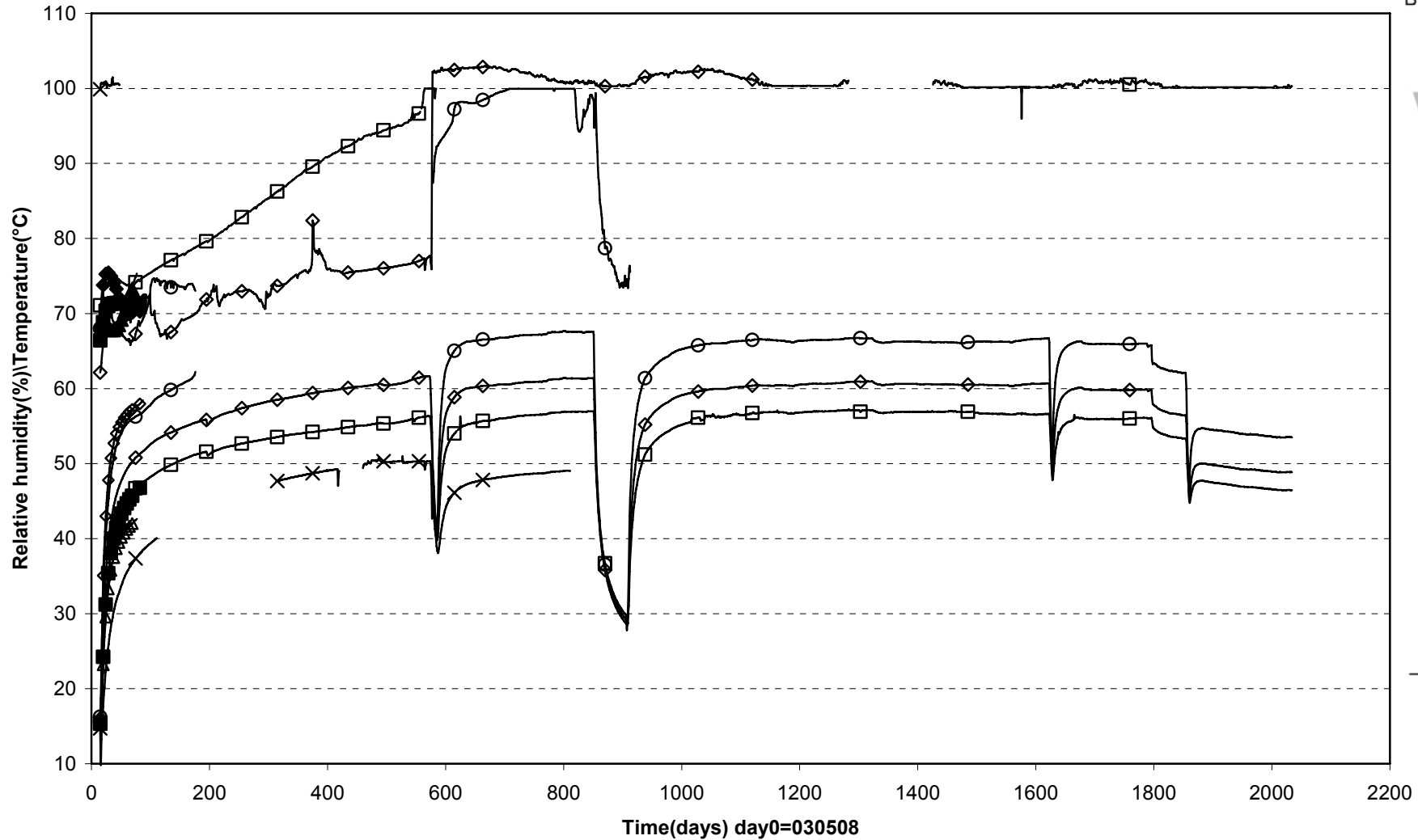

■ WB607(0.770\90°\0.685)	◆ WB609(0.770\180°\0.585)	▲ WB612(0.770\360°\0.785)	□ WB613(1.284\40°\0.735)
◇ WB615(1.284\130°\0.635)	○ WB617(1.284\230°\0.535)	× WB620(1.253\315°\0.875)	

Prototyp\Hole 6\Ring5 and Ring6 (030508-081201)
 Relative humidity - Rotronic

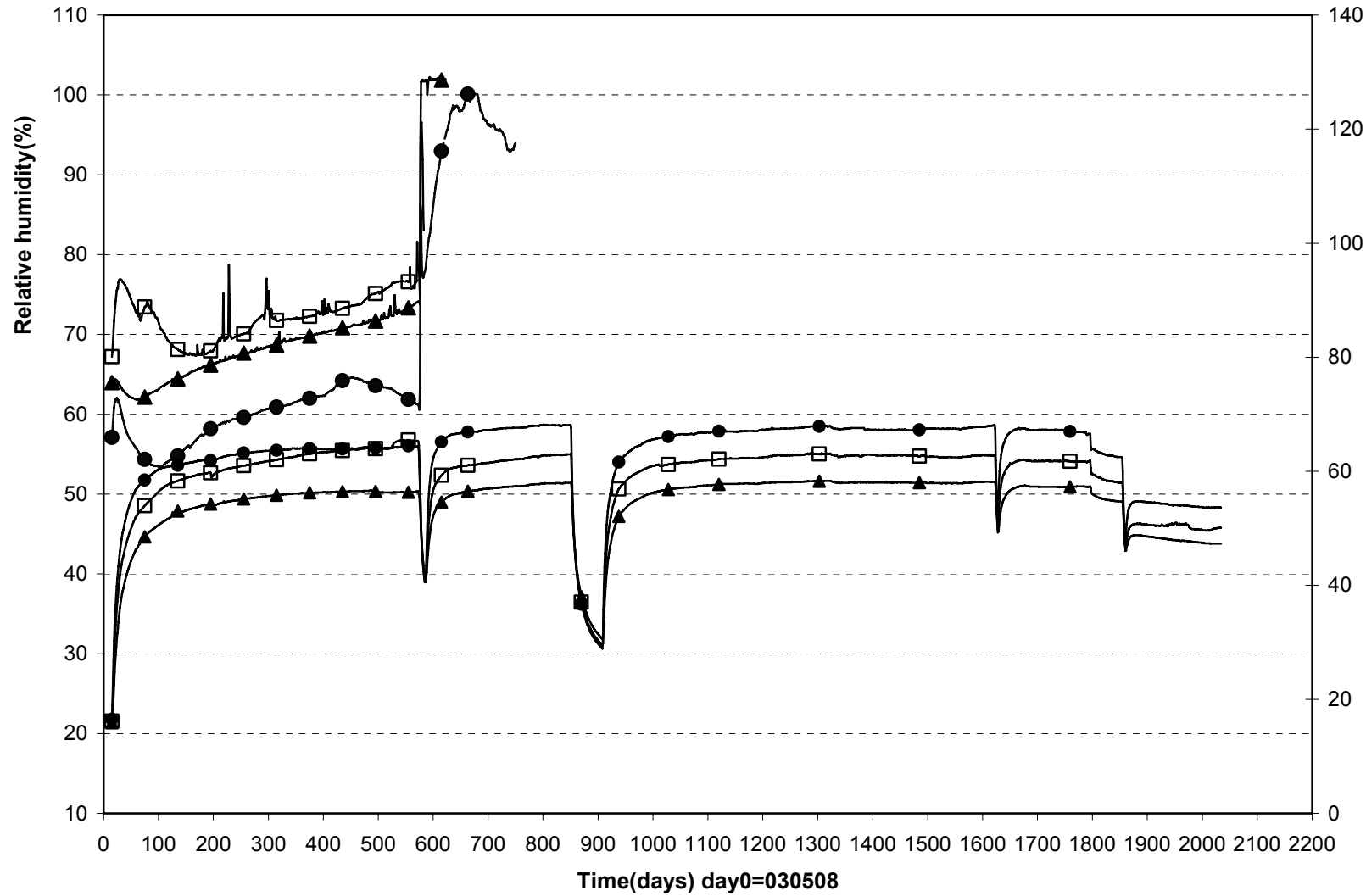

● WB623(2.795\180°\0.585) ▲ WB626(2.795\360°\0.785) □ WB621(2.795\90°\0.685)

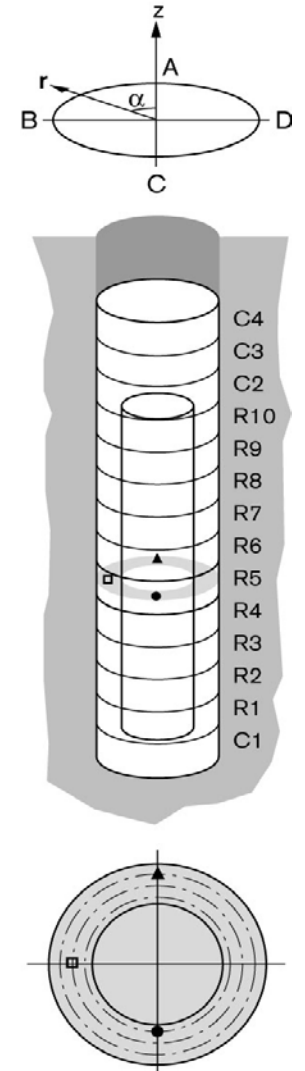

Prototype\Hole 6\ Ring 8 and Ring9 (030508-081201)
Relative humidity

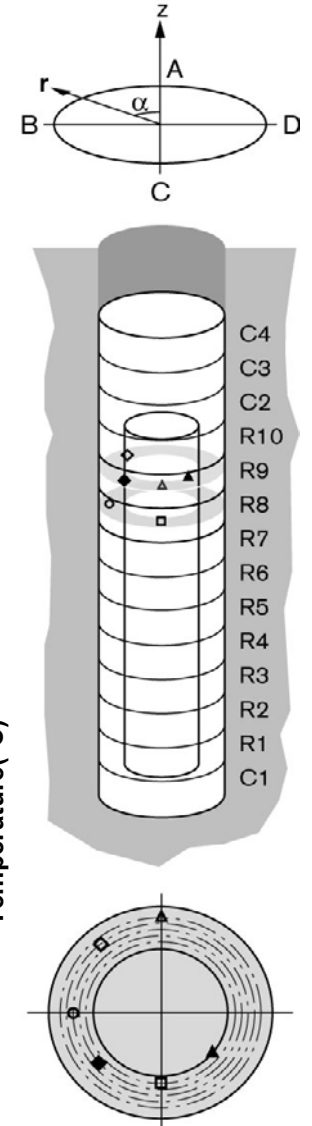
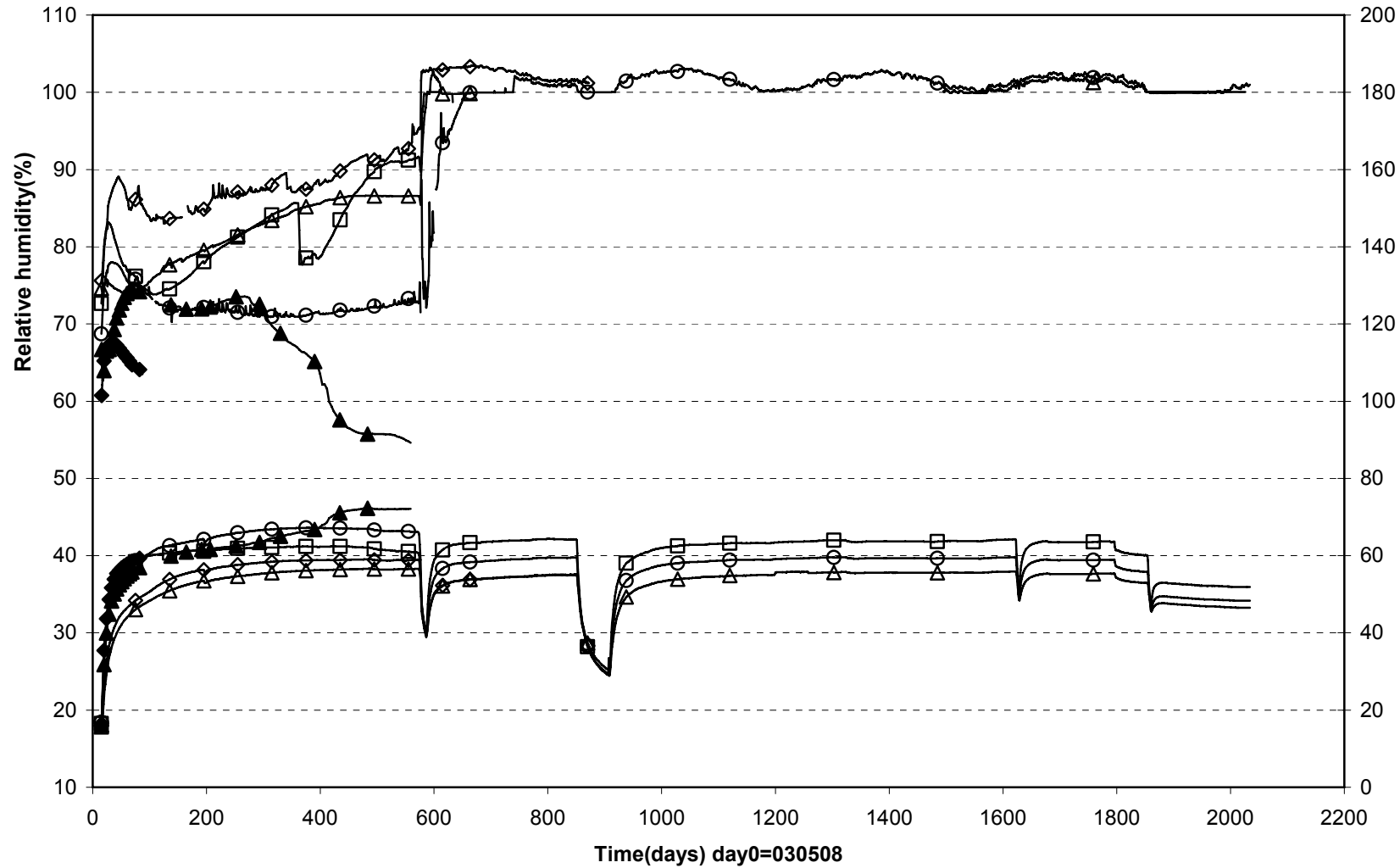

◆ WB643(4.834\130°\0.635)	▲ WB645(4.834\230°\0.535)	○ WB635(4.324\90°\0.685)	□ WB637(4.324\180°\0.585)
△ WB640(4.324\360°\0.785)	◇ WB641(4.834\40°\0.735)		

Prototype\Hole 6\ Ring10 (030508-081201)
Relative humidity

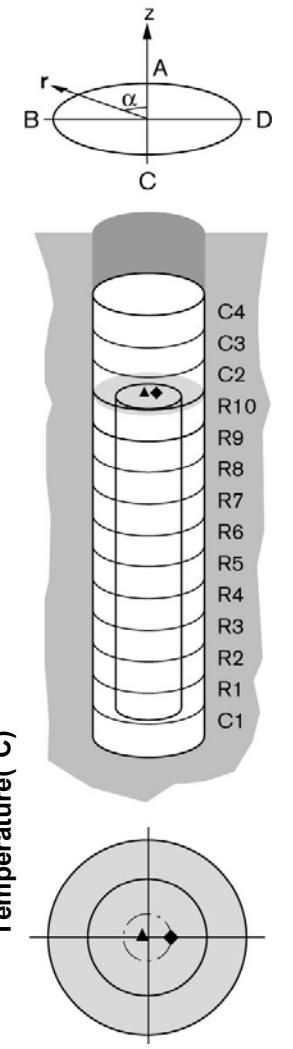
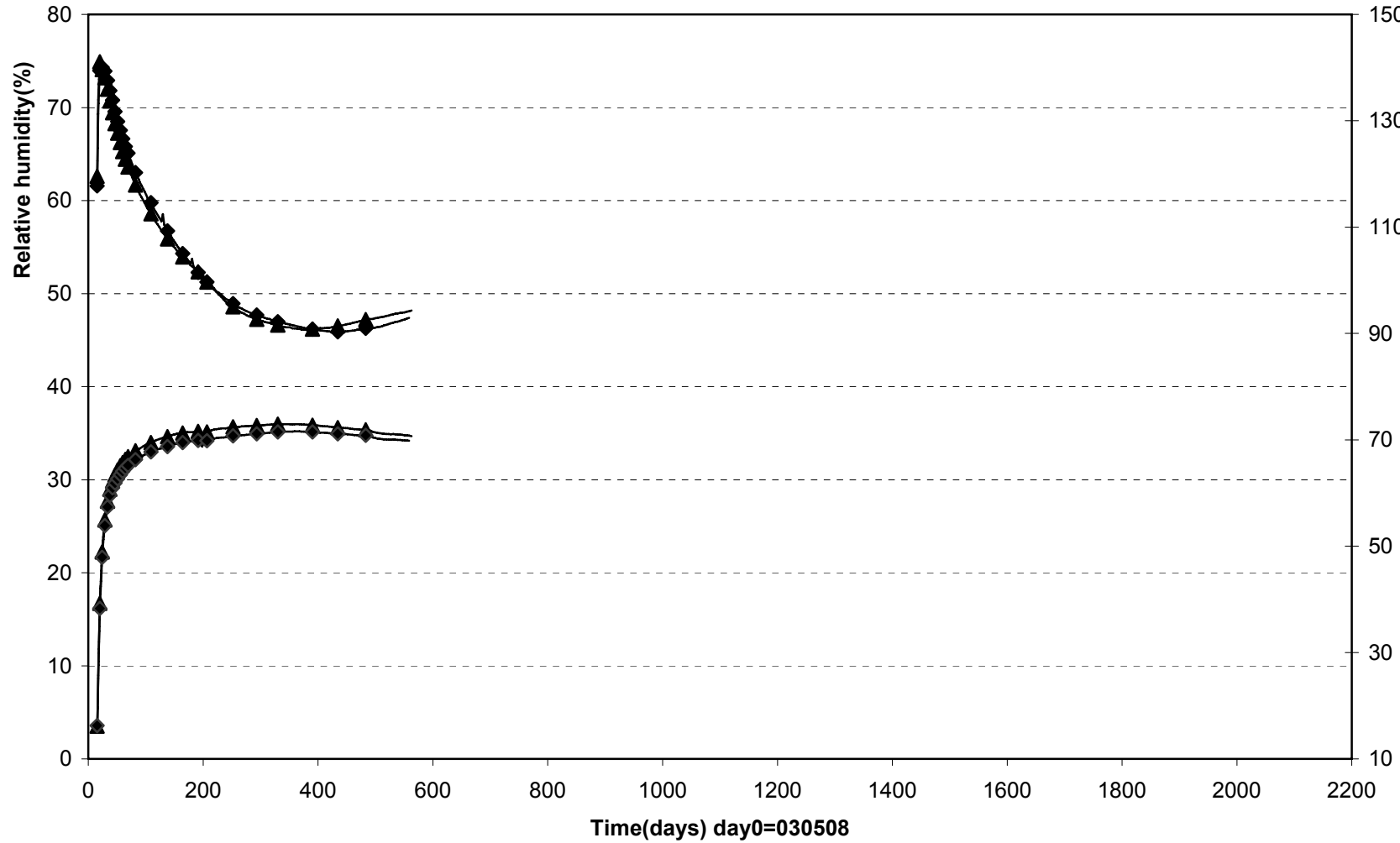

▲ WB649(5.439\90°\0.50) ◆ WB650(5.439\270°\0.210)

Prototype\Hole 6\Cyl.3 and Cyl.4 (030508-081201)

Relative humidity

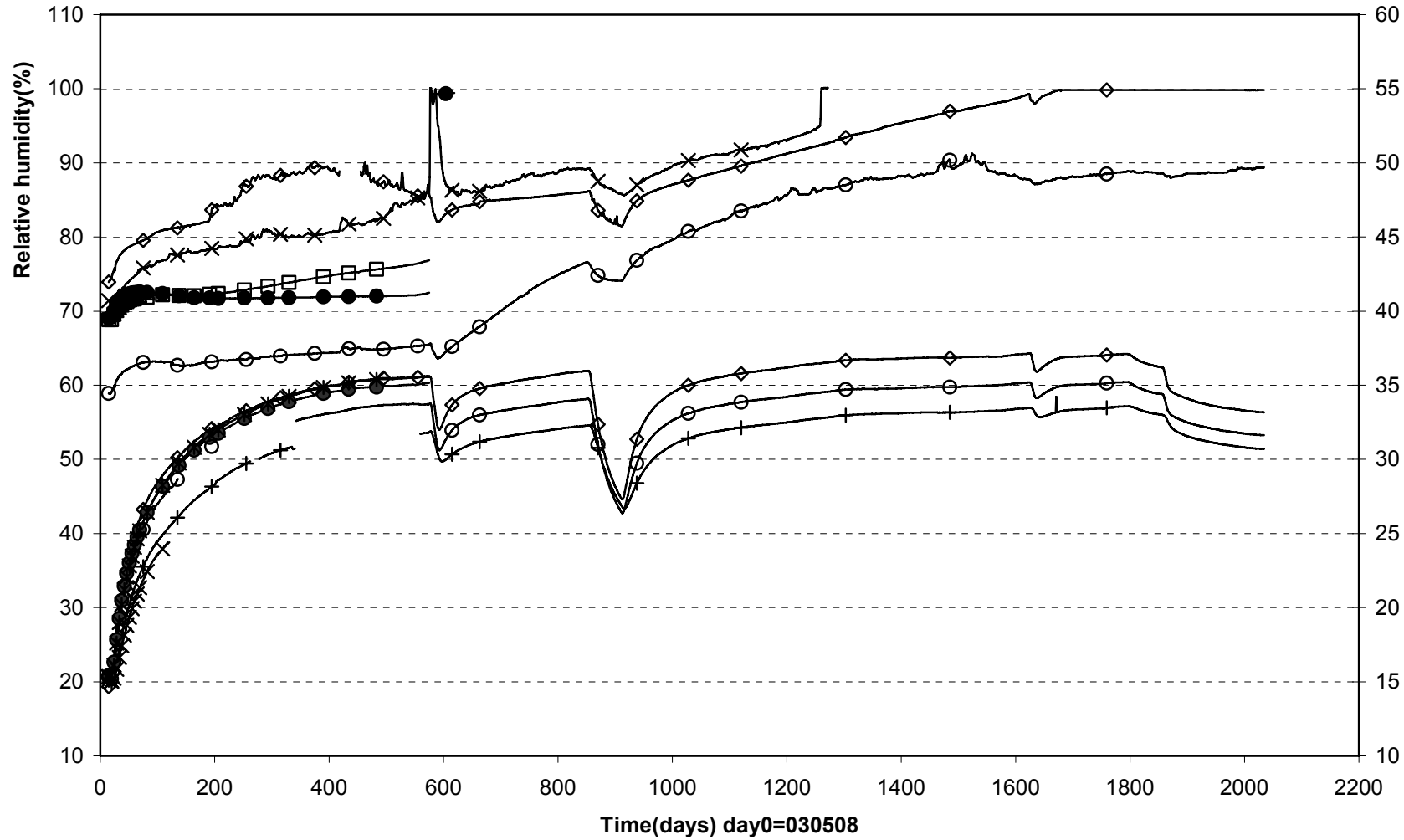

- WB652(6.366\90°\0.585) □ WB654(6.366\350°\0.585) △ WB656(6.961\270°\0.100) ◇ WB651(6.366\225°\0.100)
- WB653(6.366\180°\0.585) × WB655(6.801\180°\0.100)

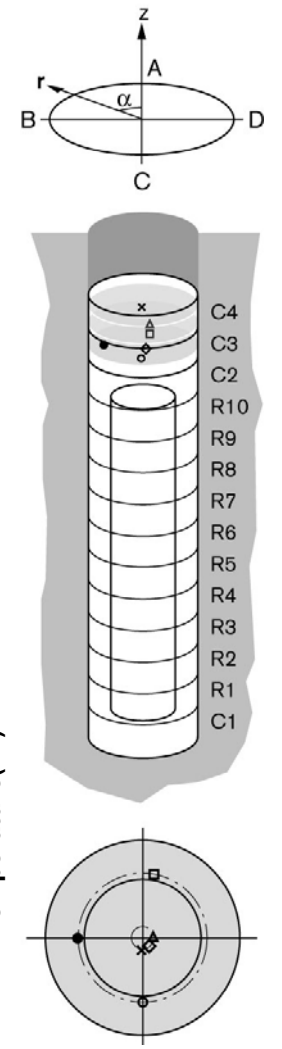

Prototype\Hole 6\Cyl.1 , Ring 6 and Ring8 (030508-081201)
 Relative humidity

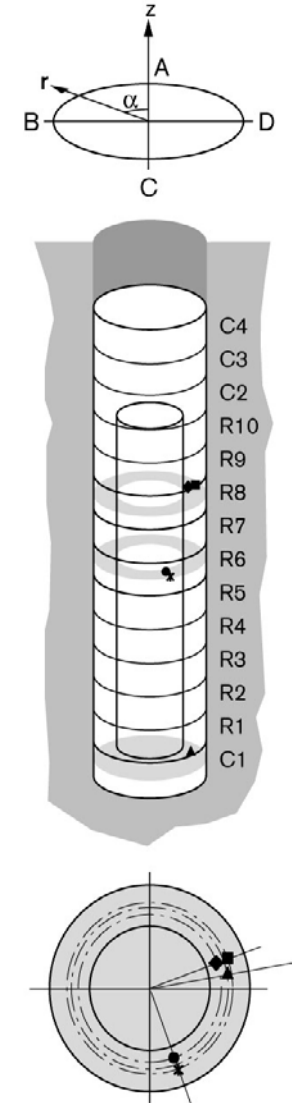
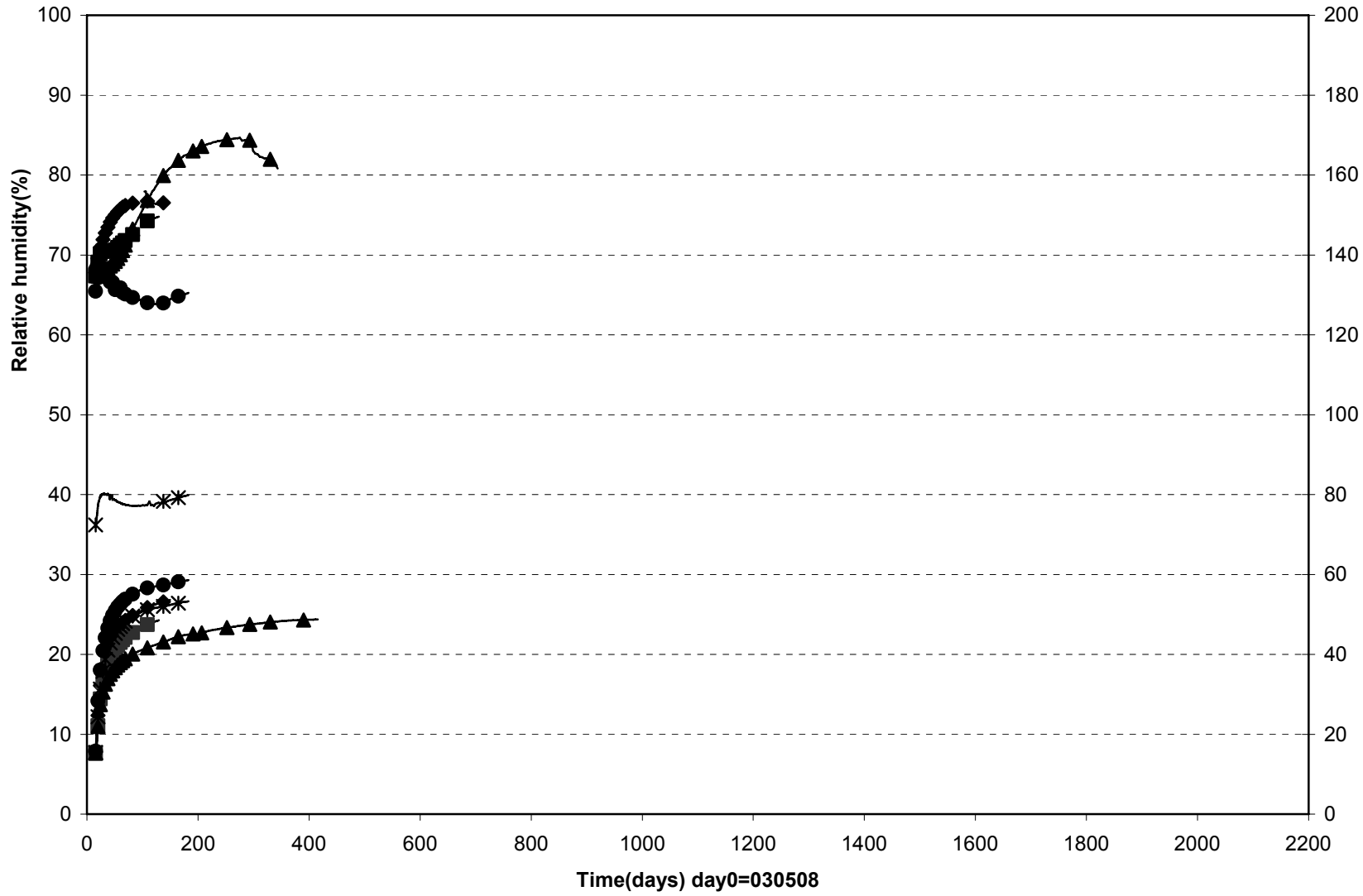

▲ WB667(0.260\280°\0.685) ● WB668(3.300\200°\0.625) ✖ WB669(3.300\200°\0.725) ◆ WB670(4.324\290°\0.625) ■ WB671(4.324\290°\0.725)

Prototype\ Hole 6 \Rock (030508-081201)
Suction - Wescor

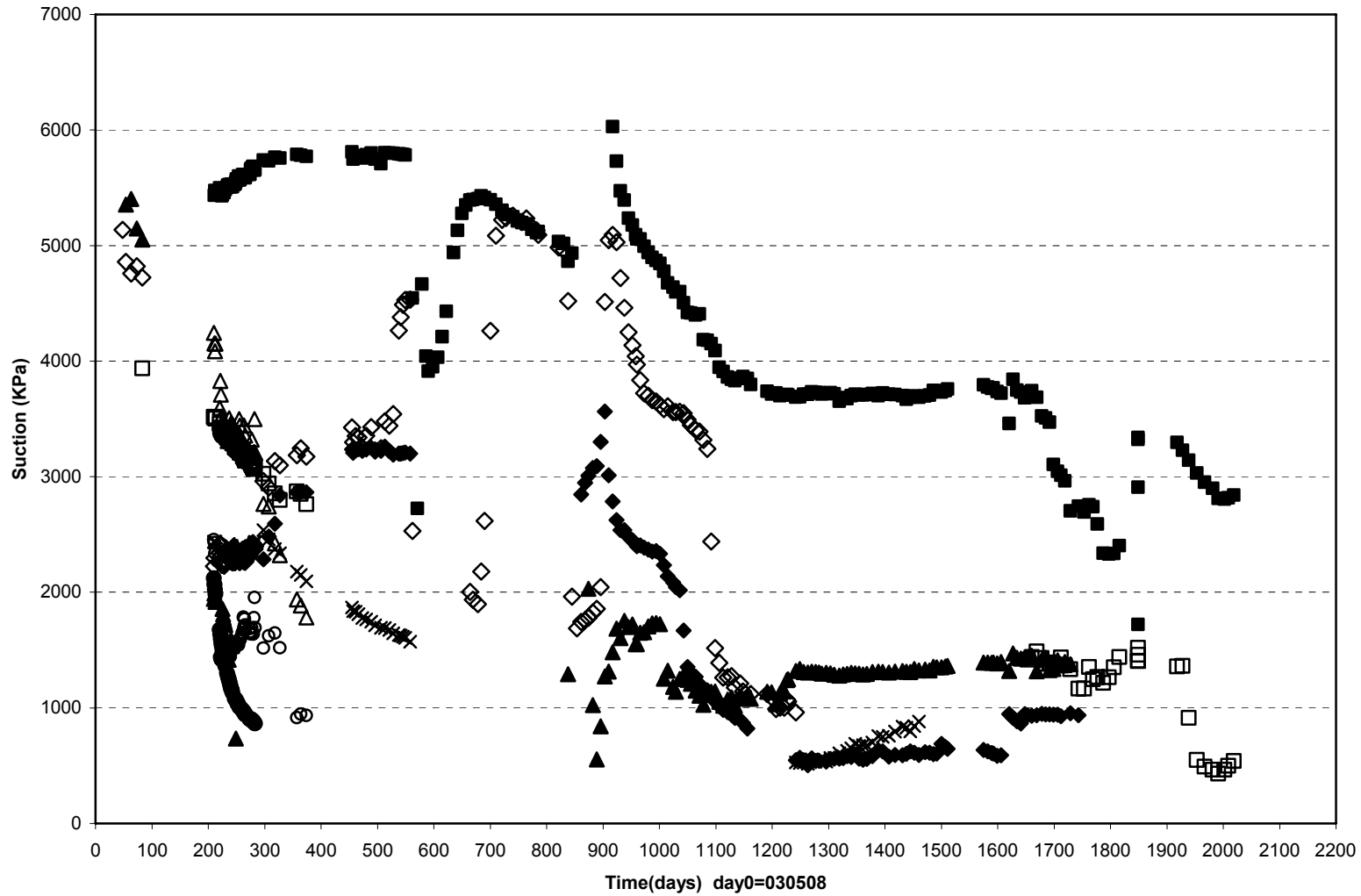

◆ WB659(3.100\190°\0.900\Rock)	■ WB660(3.250\190°\0.925\Rock)	▲ WB661(3.400\190°\0.975\Rock)
△ WB664(4.100\280°\0.900\Rock)	□ WB665(4.250\280°\0.925\Rock)	◇ WB666(4.400\280°\0.975\Rock)
○ WB619(1.253\305°\0.875\Rock)	● WB633(3.253\305°\0.875\Rock)	× WB647(4.753\305°\0.875\Rock)

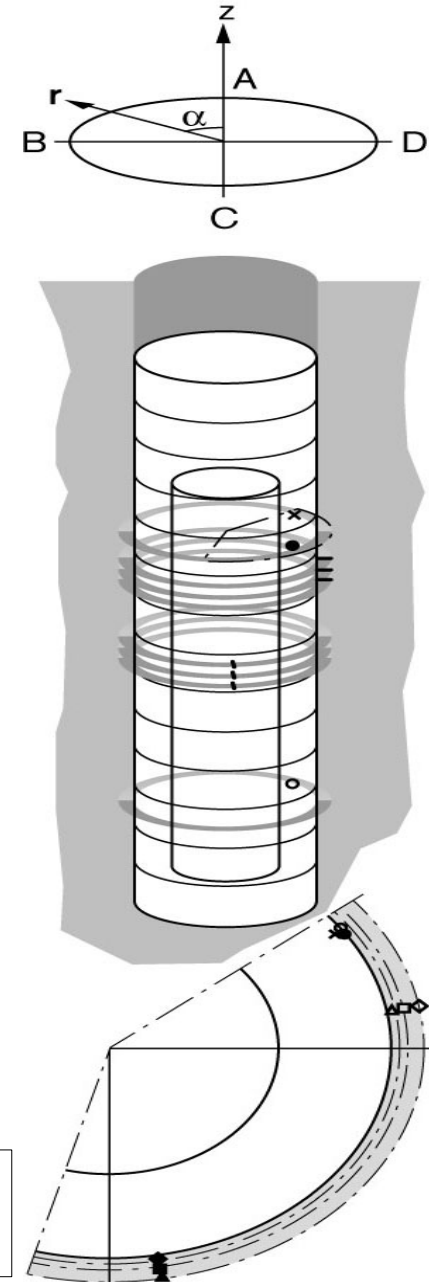

Prototype\ Hole 6 \ Cyl1 (030508-081201)
Suction - Wescor

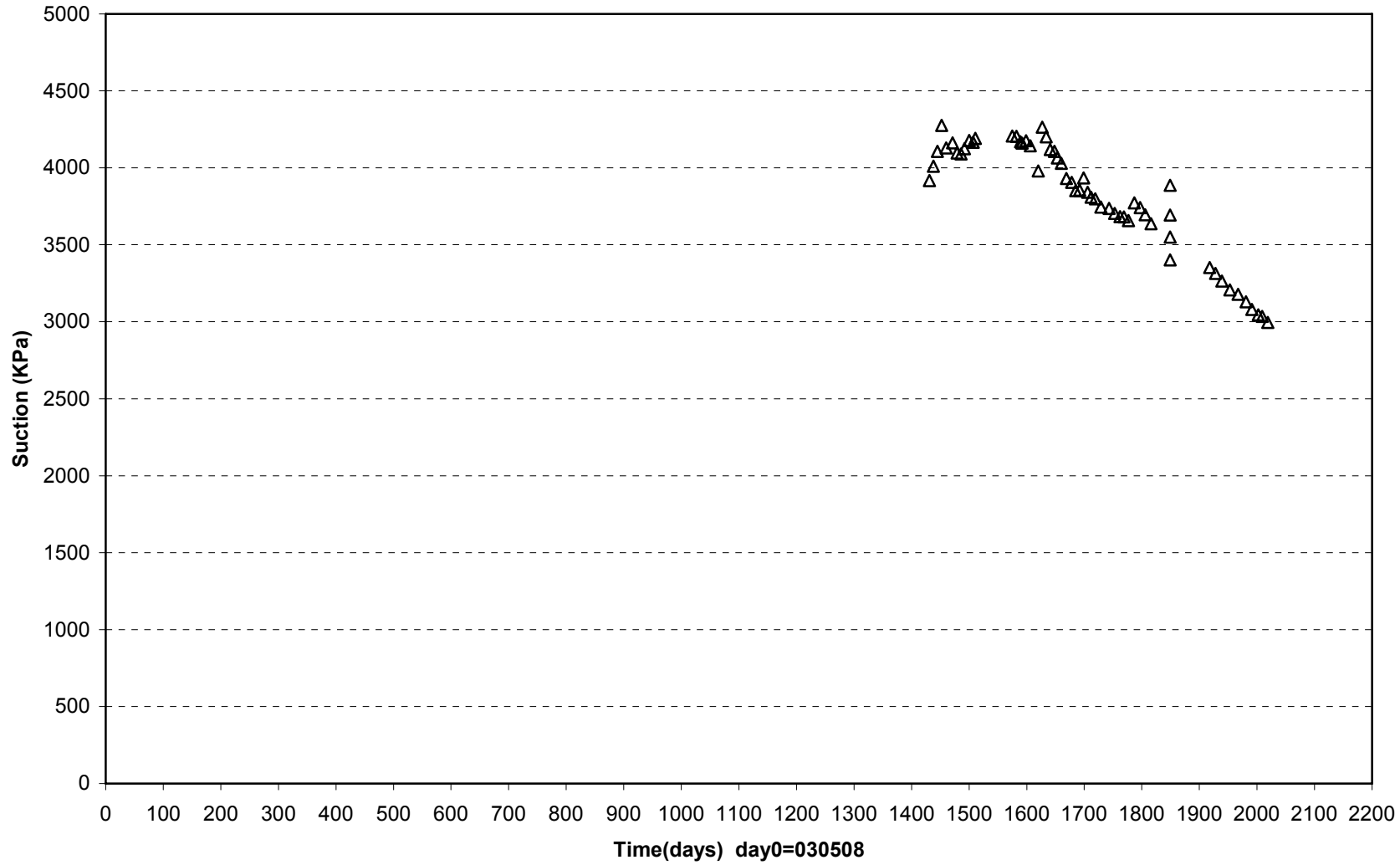

□ WB602(0.260\225°\0.050) ◆ WB603(0.260\260°\0.210) △ WB605(0.260\90°\0.685)

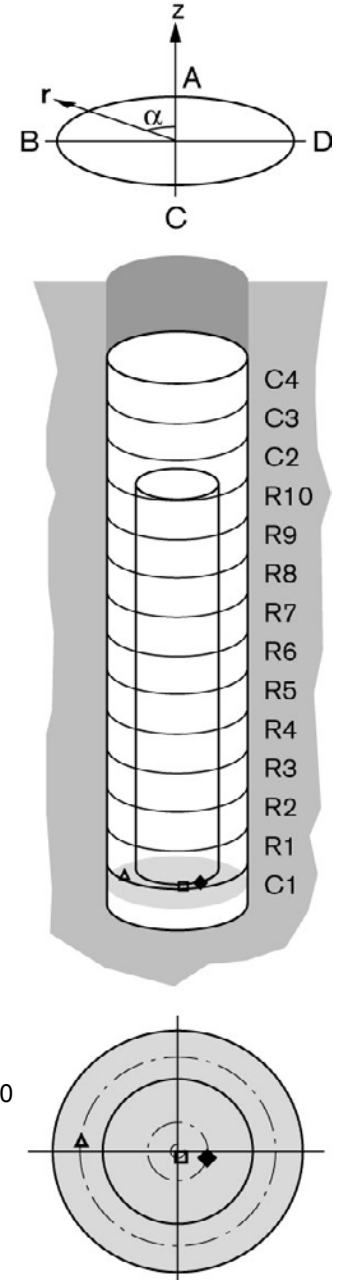

Prototype \ Hole 6 \ Ring 1 and Ring 2 (030508-081201)
Suction - Wescor

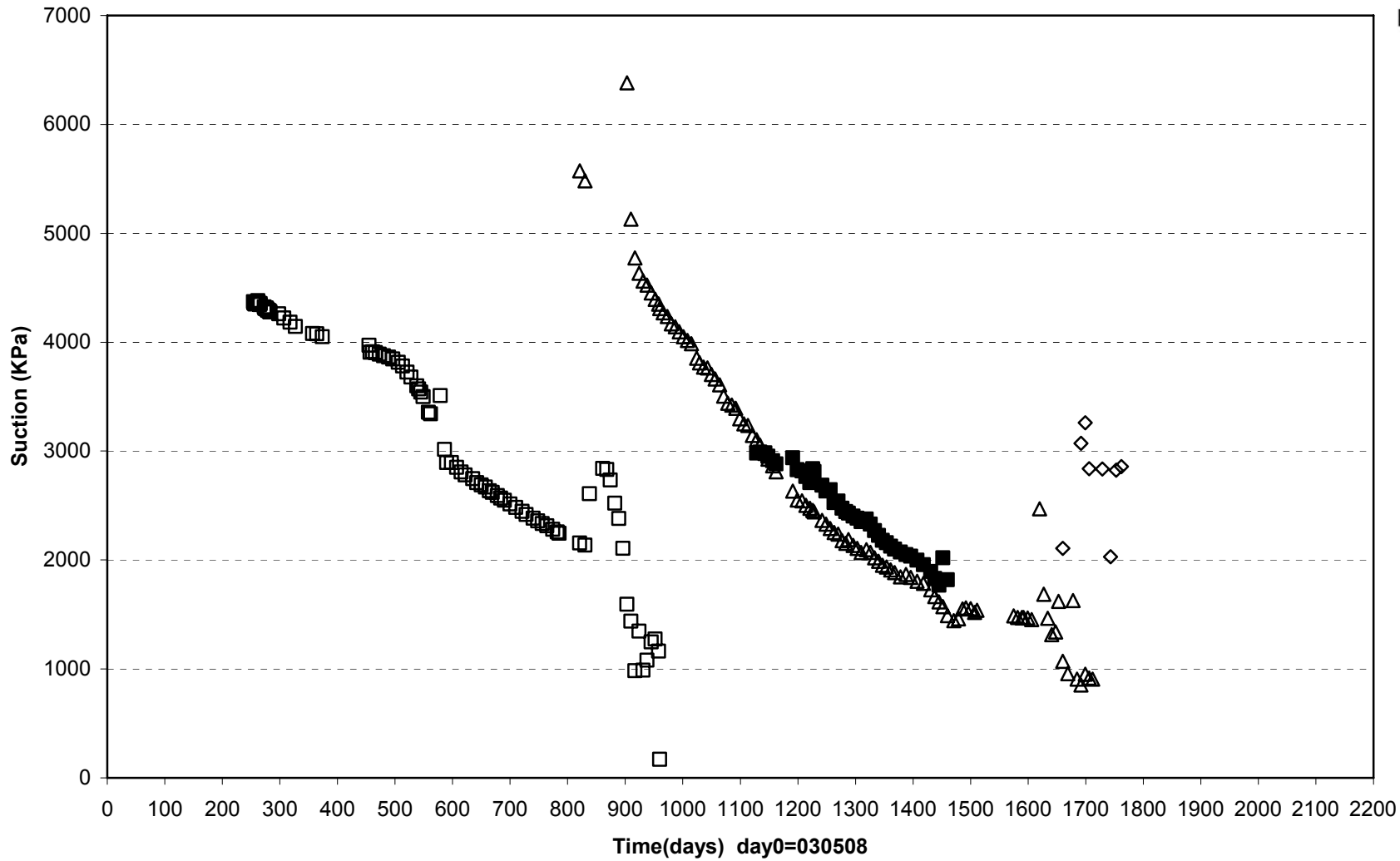

- WB608(0.770\95°\0.685)
- ◆ WB612(0.750\185°\0.585)
- WB611(0.770\355°\0.785)
- △ WB614(1.284\45°\0.735)
- WB616(1.284\135°\0.635)
- ◇ WB618(1.284\235°\0.535)

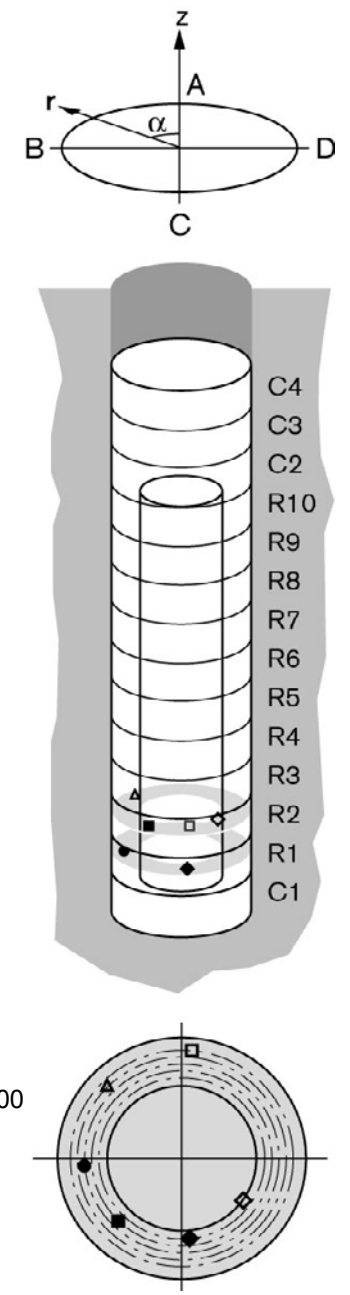

Prototype\ Hole 6 \ Ring 5 and Ring 6 (030508-081201)
Suction - Wescor

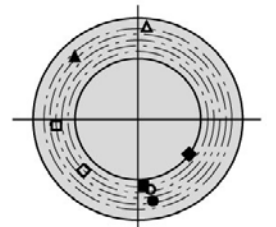
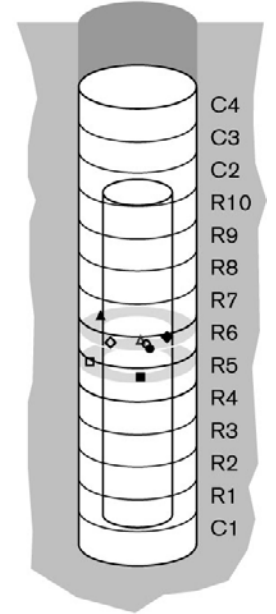
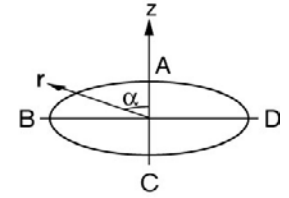
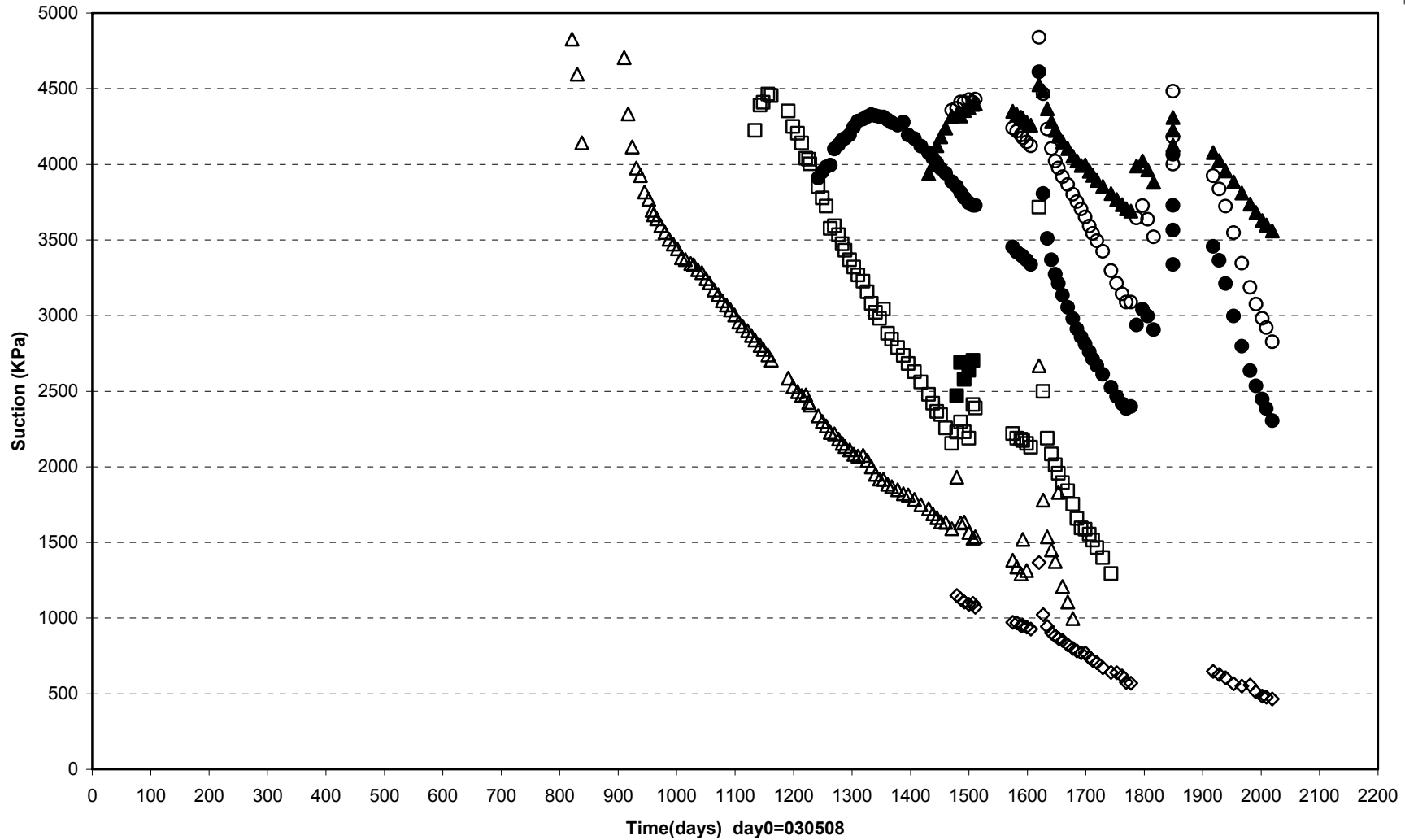

- WB622(2.795\95°\0.685) ■ WB624(2.795\185°\0.585) △ WB625(2.795\355°\0.785) ▲ WB628(3.300\45°\0.735)
- ◇ WB630(3.300\135°\0.635) ◆ WB632(3.300\235°\0.535) ○ WB657(3.300\190°\0.625) ● WB658(3.300\190°\0.725)

Prototype\ Hole 6 \ Ring 6 and Ring 8 (030508-081201)
Suction - Wescor

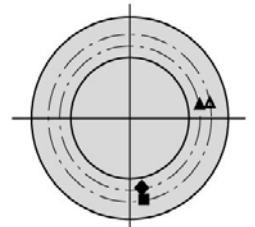
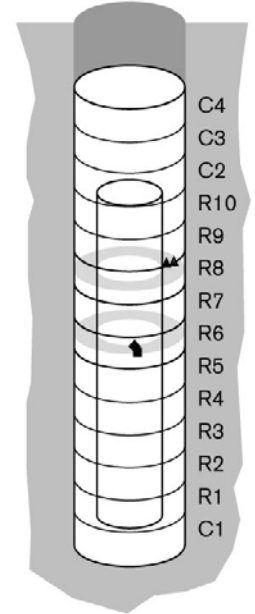
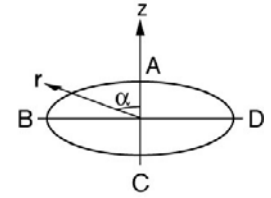
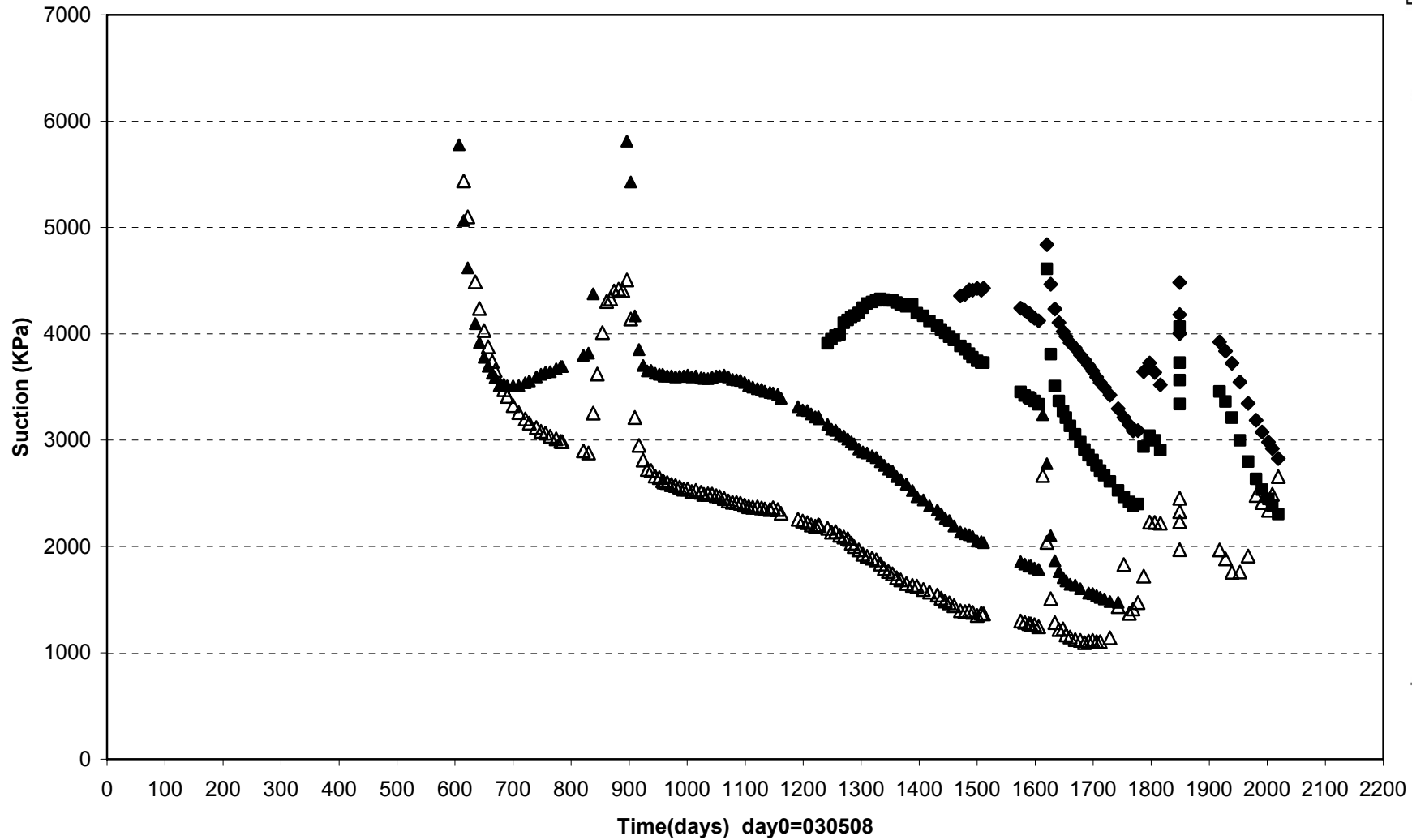

◆ WB657(3.300\190°\0.625) ■ WB658(3.300\190°\0.725) ▲ WB662(4.324\280°\0.625) ▽ WB663(4.324\280°\0.725)

Prototype\Hole6 \Cyl.1 and Ring2 (030508-081201)
 Pore pressure

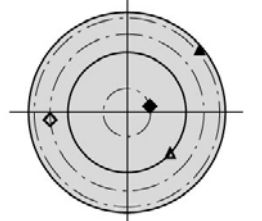
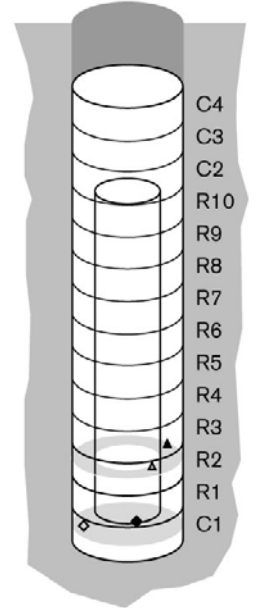
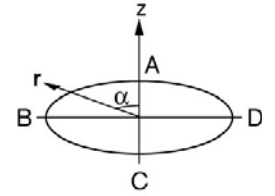
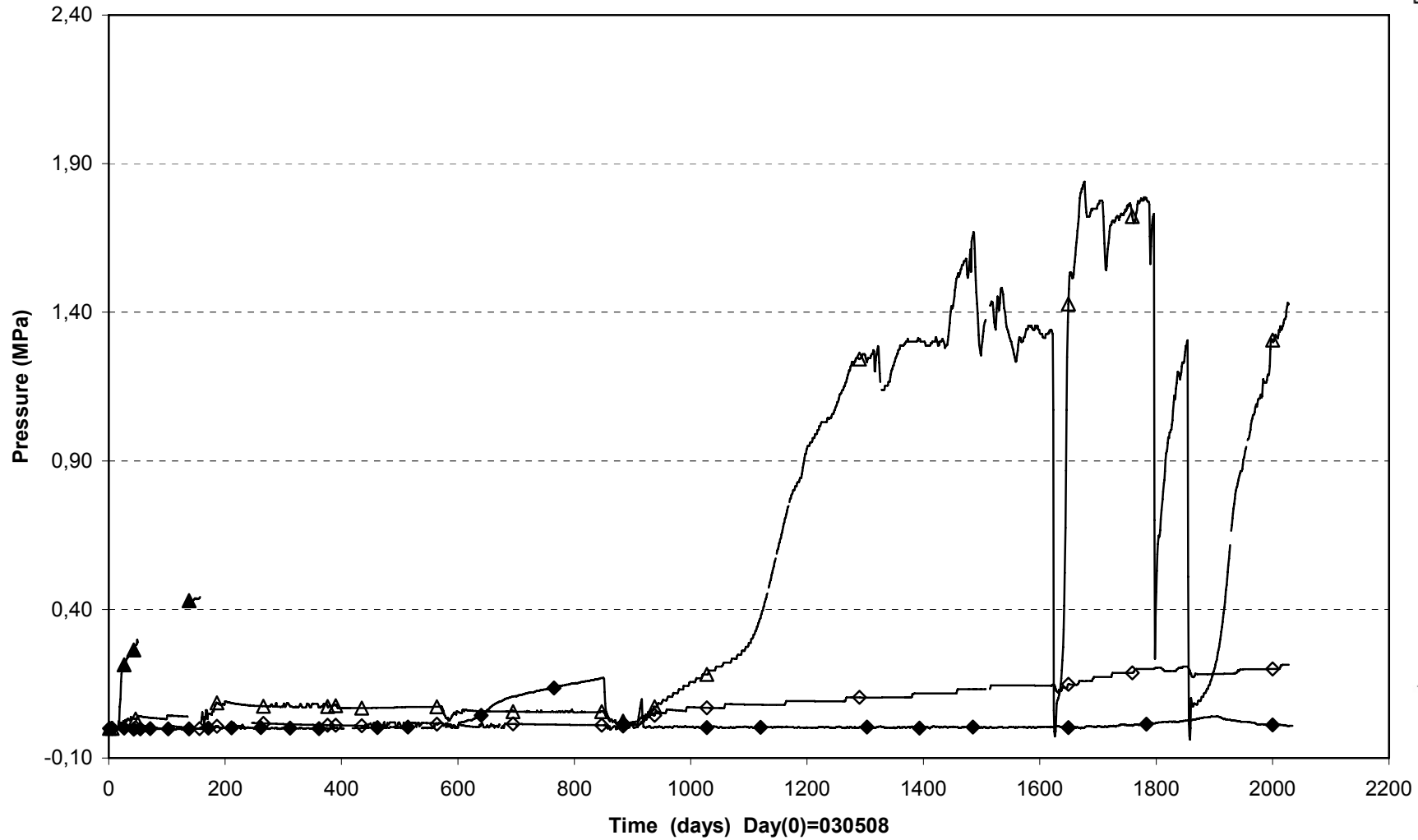

◆ UB601(0.260 \280^\ 0.210) ◇ UB602(0.260\95^\0.685) △ UB603(1.284\225^\0.535) ▲ UB604(1.253 \310^\ 0.875)

Prototype\Hole6 \ Ring 5 and Ring 6 (030508-081201)
 Pore pressure

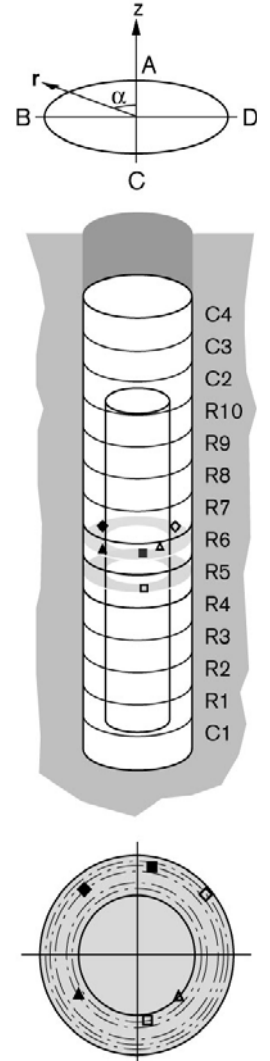
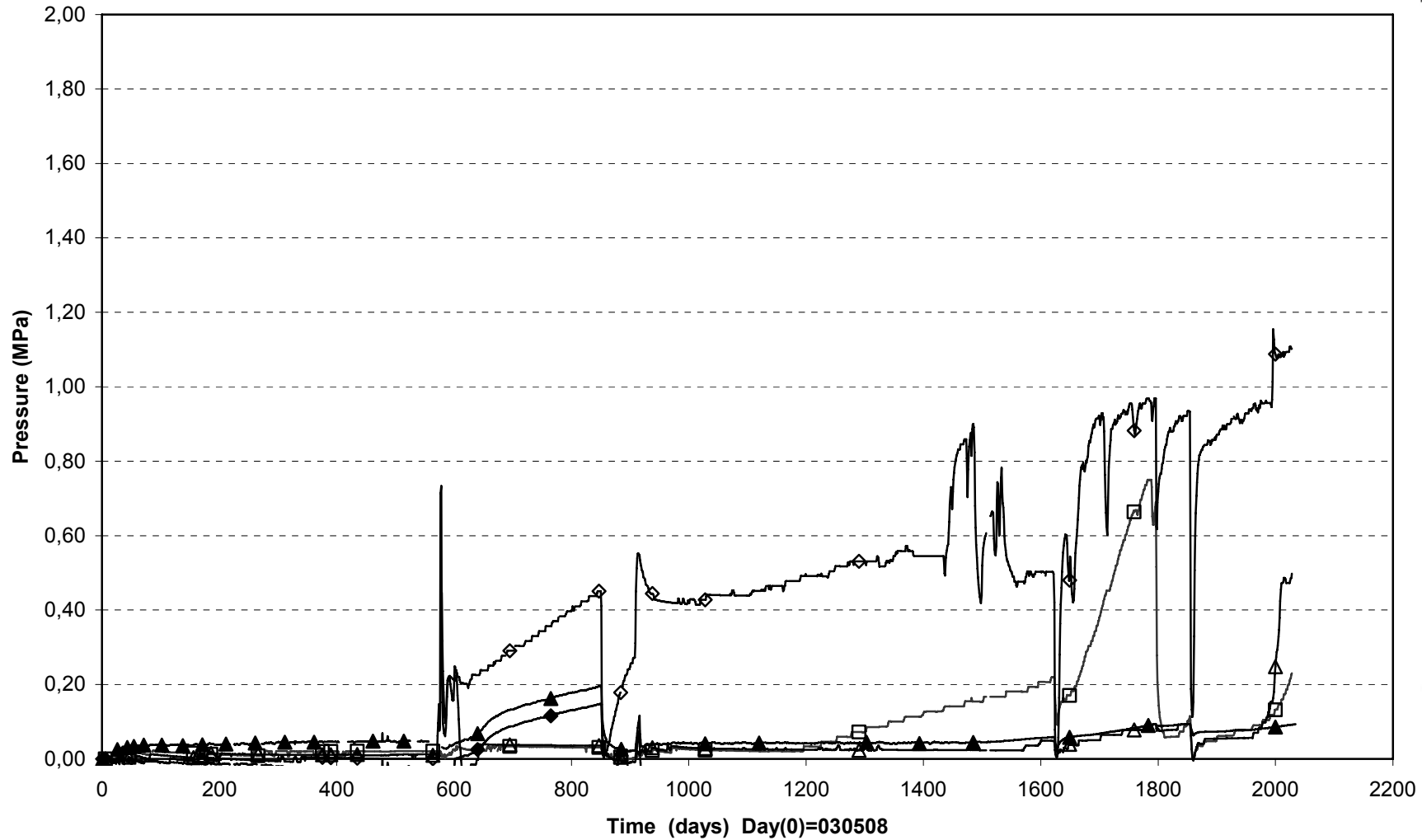

□ UB605(2.795\190°\0.585)	■ UB606(2.795 \350°\ 0.785)	◆ UB607(3.300 \35°\ 0.735)
▲ UB608(3.300 \125°\ 0.635)	△ UB609(3.300\225°\0.535)	◇ UB610(3.253\310°\0.875)

Prototype\Hole6\Ring 9 , Cyl.3 and Cyl.4 (030508-081201)
 Pore pressure

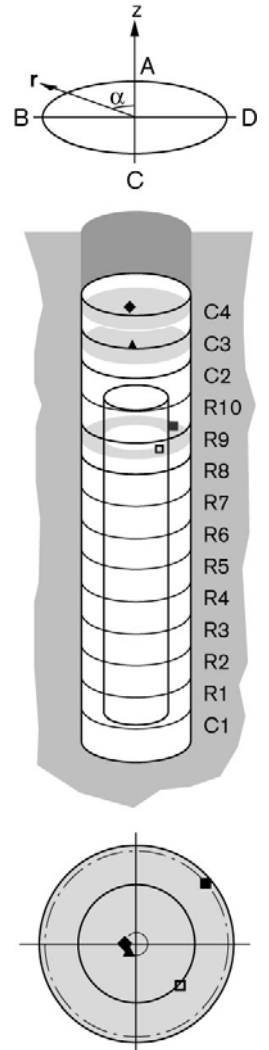
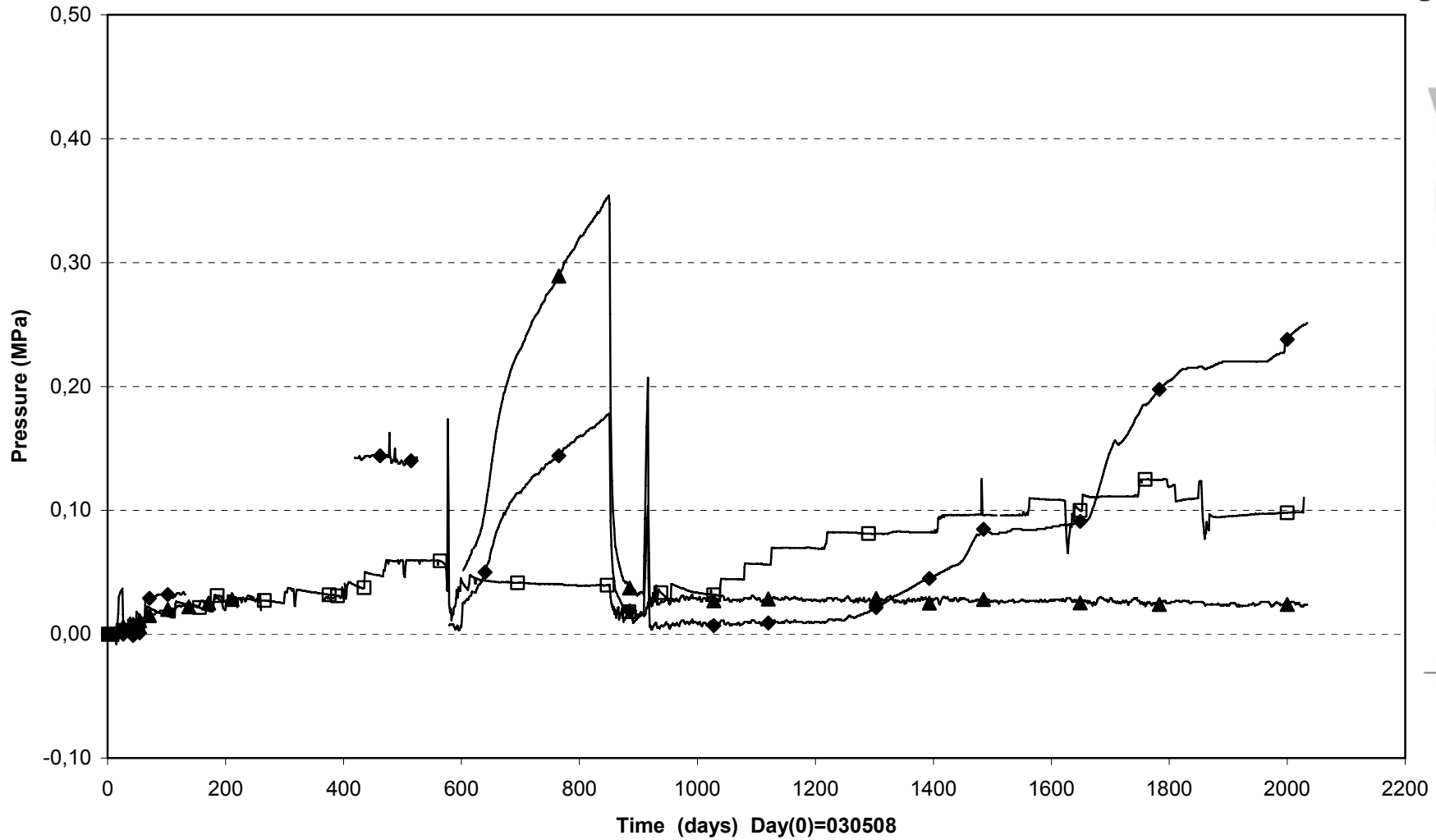

□ UB611(4.834\225°\0.535)
■ UB612(4.753 \310°\ 0.875)
▲ UB613(6.366 \135°\ 0.100)
◆ UB614(6.961 \90°\ 0.100)

Prototype\Hole 6\Cyl.1 and Ring1 (030508-081201)
 Temperature - Pentronic

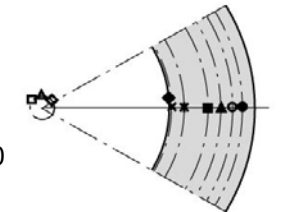
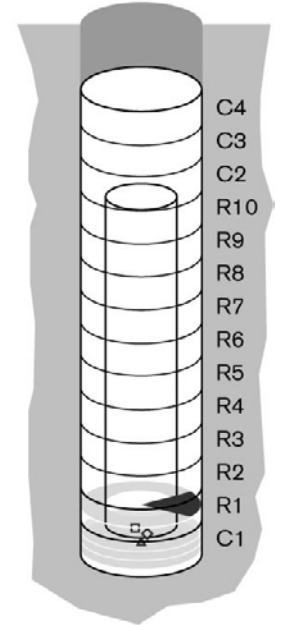
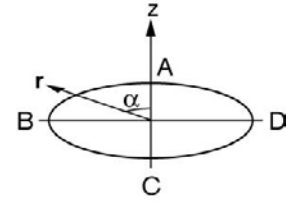
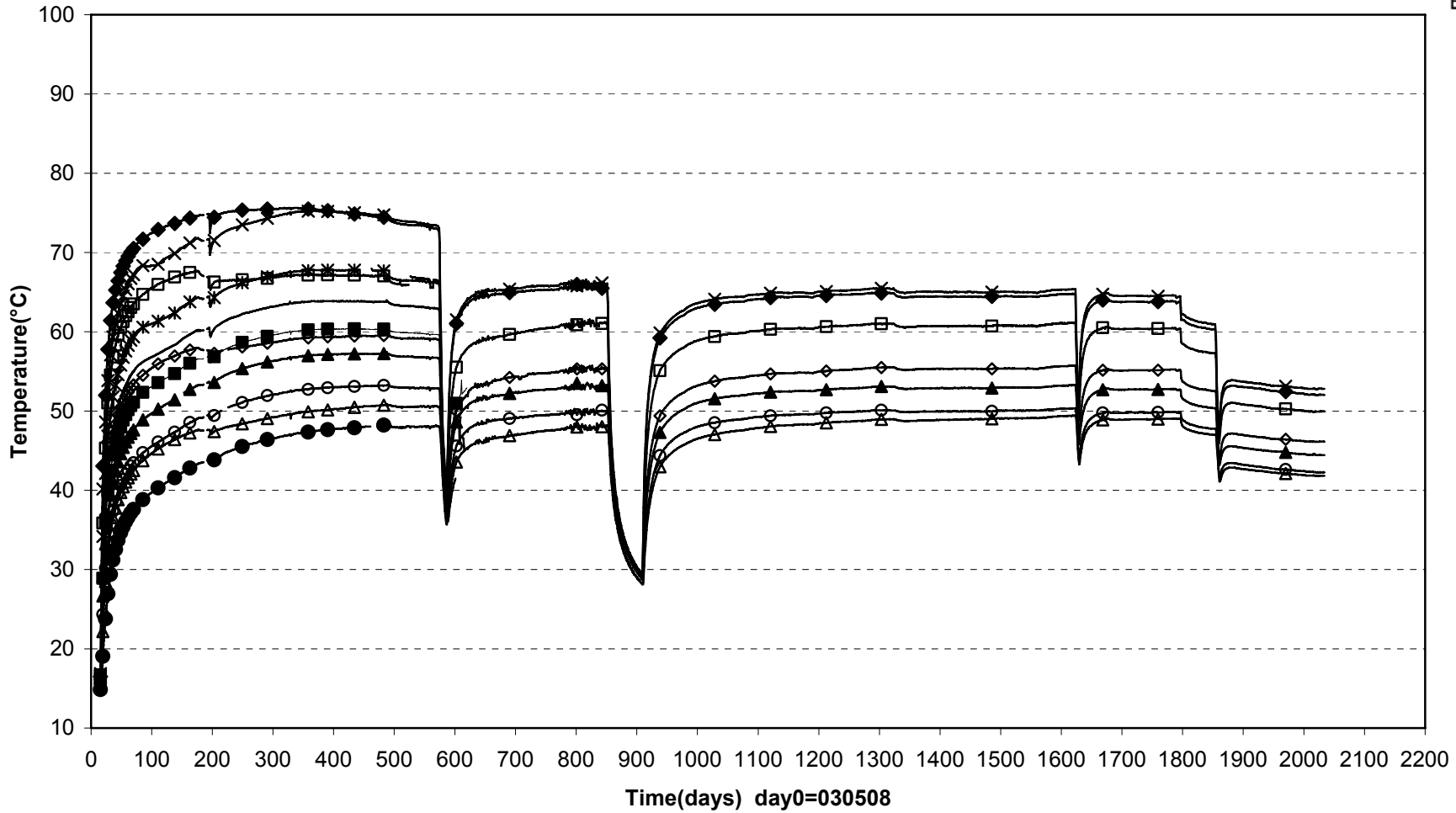

□ TB601(0.385\45°\0.050)	◇ TB602(0.260\315°\0.050)	△ TB603(0.135\0°\0.050)	× TB604(0.770\270°\0.535)
× TB605(0.770\270°\0.585)	■ TB607(0.770\270°\0.685)	▲ TB608(0.770\270°\0.735)	○ TB609(0.770\270°\0.785)
● TB610(0.753\270°\0.875)	◆ TB611(0.753\ 0°\0.525)	— TB606(0.750\270°\0.635)	

Prototype\Hole 6 \Ring5 (030508-081201)
 Temperature - Pentronic

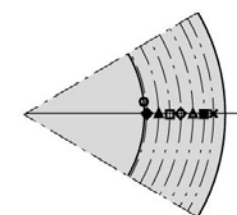
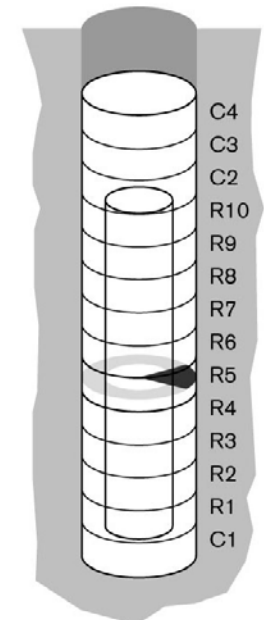
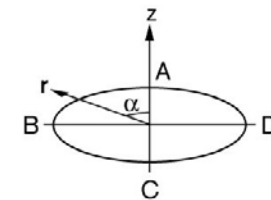
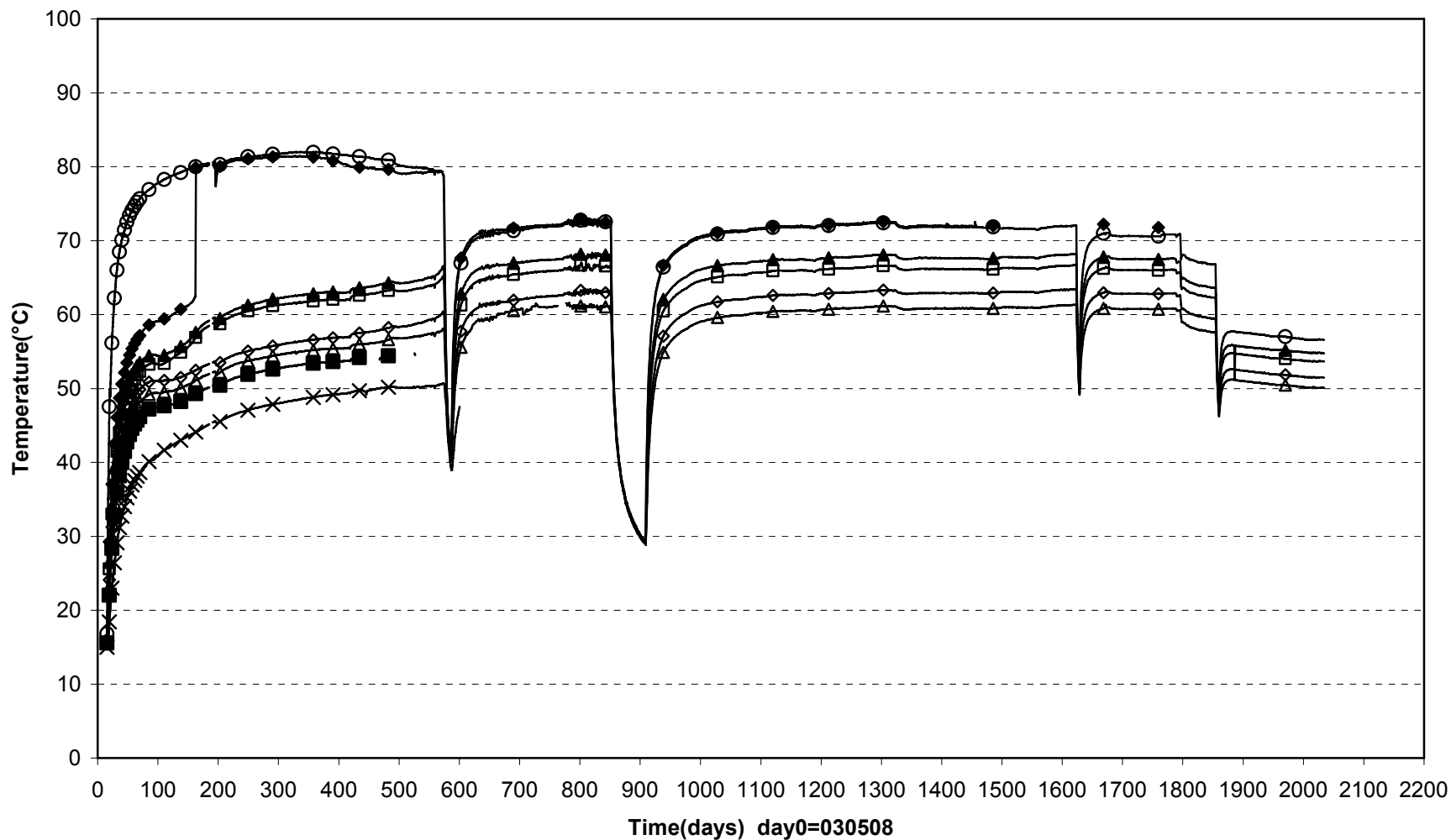

◆ TB612(2.795\270°\0.535) ▲ TB613(2.795\270°\0.585) □ TB614(2.795\270°\0.635) ◇ TB615(2.795\270°\0.685) △ TB616(2.795\270°\0.735)
 ■ TB617(2.795\270°\0.785) × TB618(2.753\270°\0.875) ○ TB619(2.753\ 0°\0.525)

Prototype\Hole 6 \Ring8 (030508-081201)
 Temperature - Pentronic

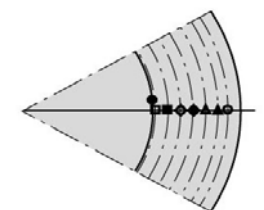
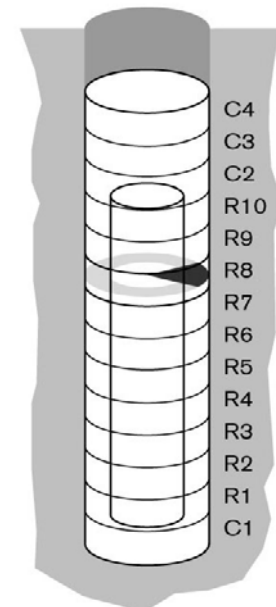
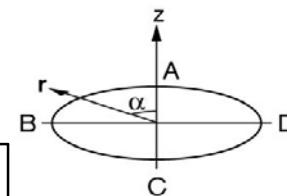
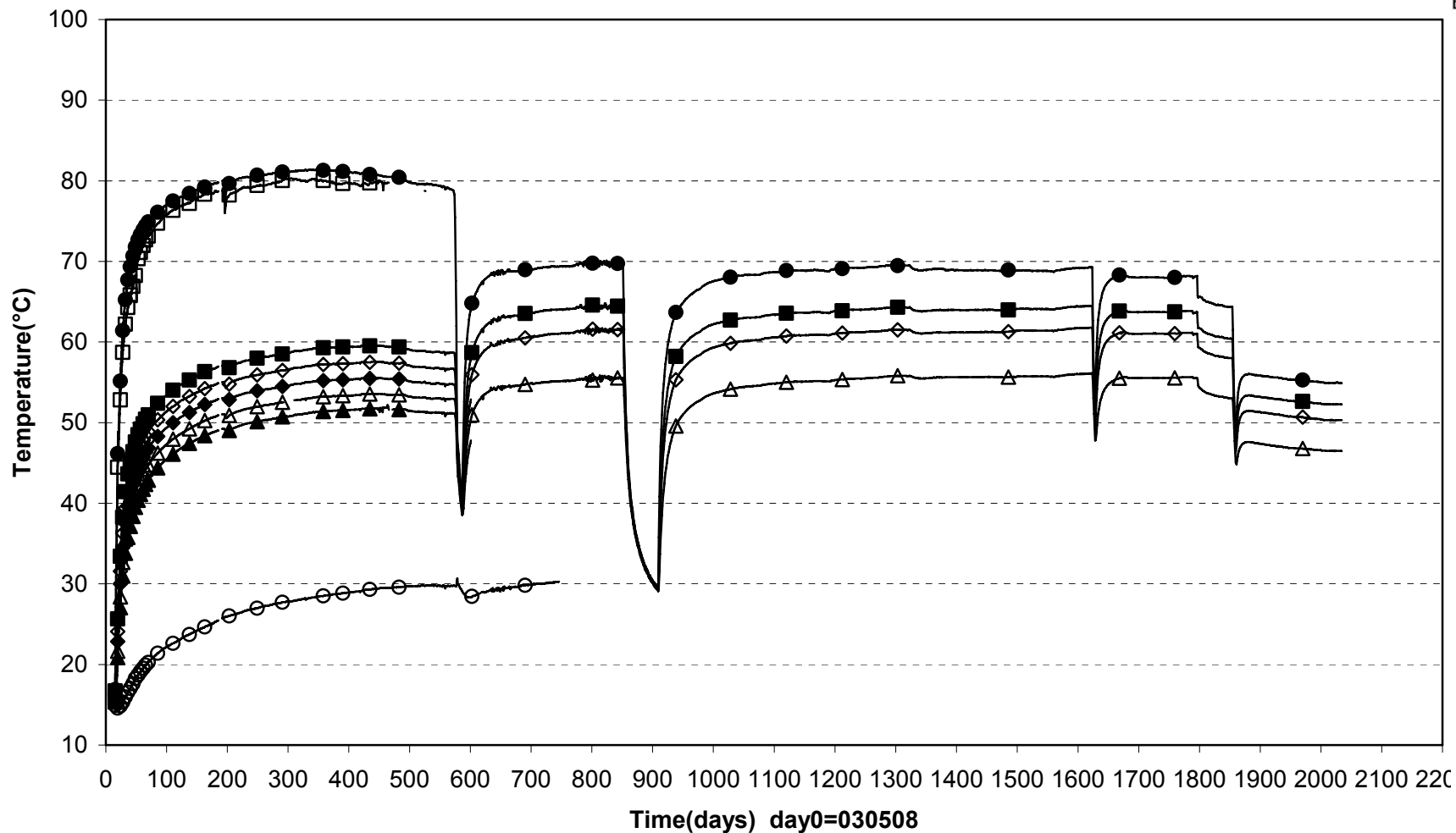

- TB620(4.324\270°\0.535) ■ TB621(4.324\270°\0.585) ◇ TB622(4.324\270°\0.635) ◆ TB623(4.324\270°\0.685)
- △ TB624(4.324\270°\0.735) ▲ TB625(4.324\270°\0.785) ○ TB626(4.253\270°\0.875) ● TB627(4.253\0°\0.525)

Prototype\Hole 6 \Cyl.3 and Cyl.4 (030508-081201)
 Temperature - Pentronic

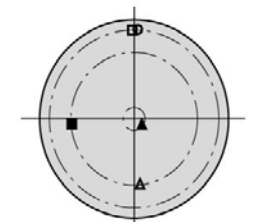
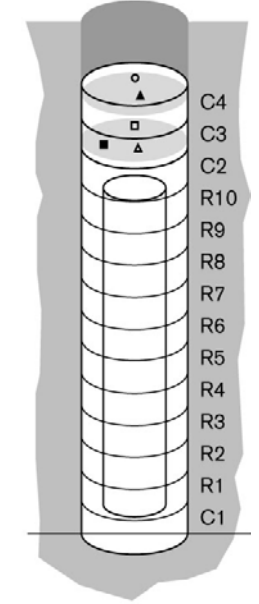
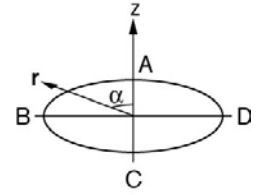
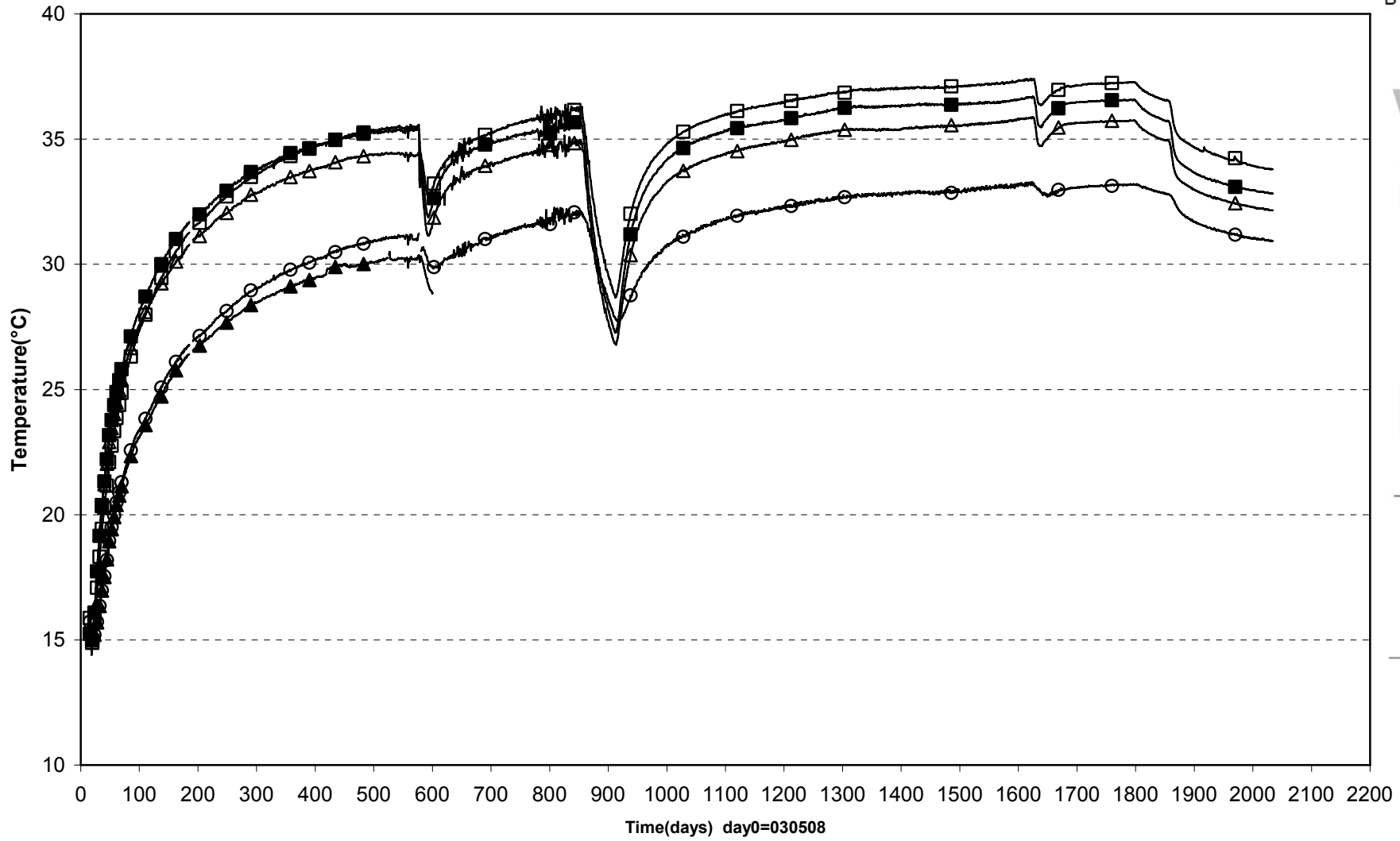

□ TB628(6.366\0°\0.785) ■ TB629(6.366\95°\0.585) △ TB630(6.366\185°\0.585) ▲ TB631(7.071\225°\0.100) ○ TB632(7.071\0°\0.785)

Prototype\Hole 6\Cyl.1 and Ring2 (030508-081201)
 Temperature - Geokon

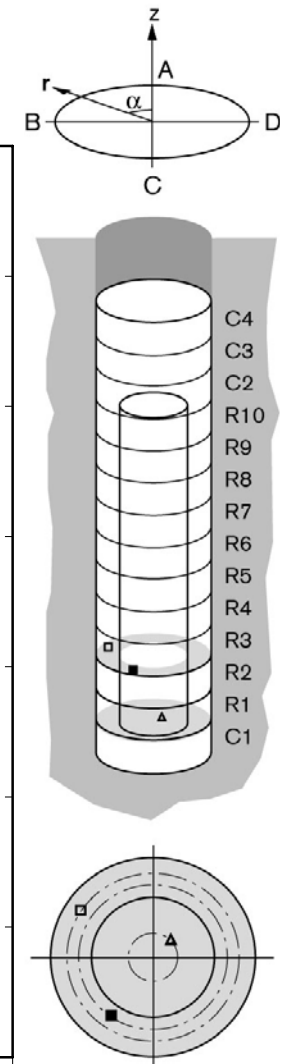
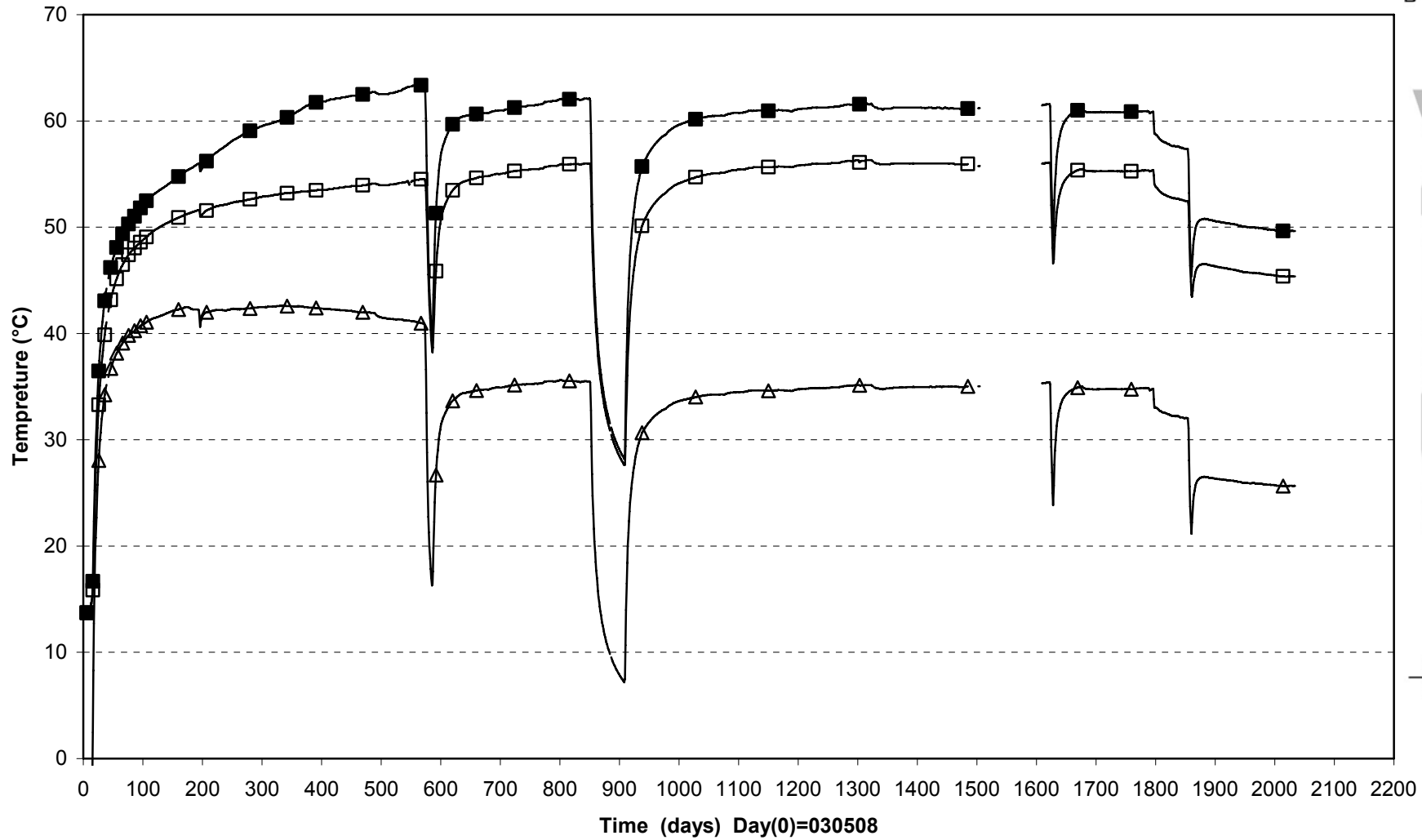

△ PB601T(0.510\315°\0.210)
□ PB606T(1.534\55°\0.735)
■ PB607T(1.534\145°\0.635)

Prototype\Hole 6\ Ring6 (030508-081201)
 Temperature - Geokon

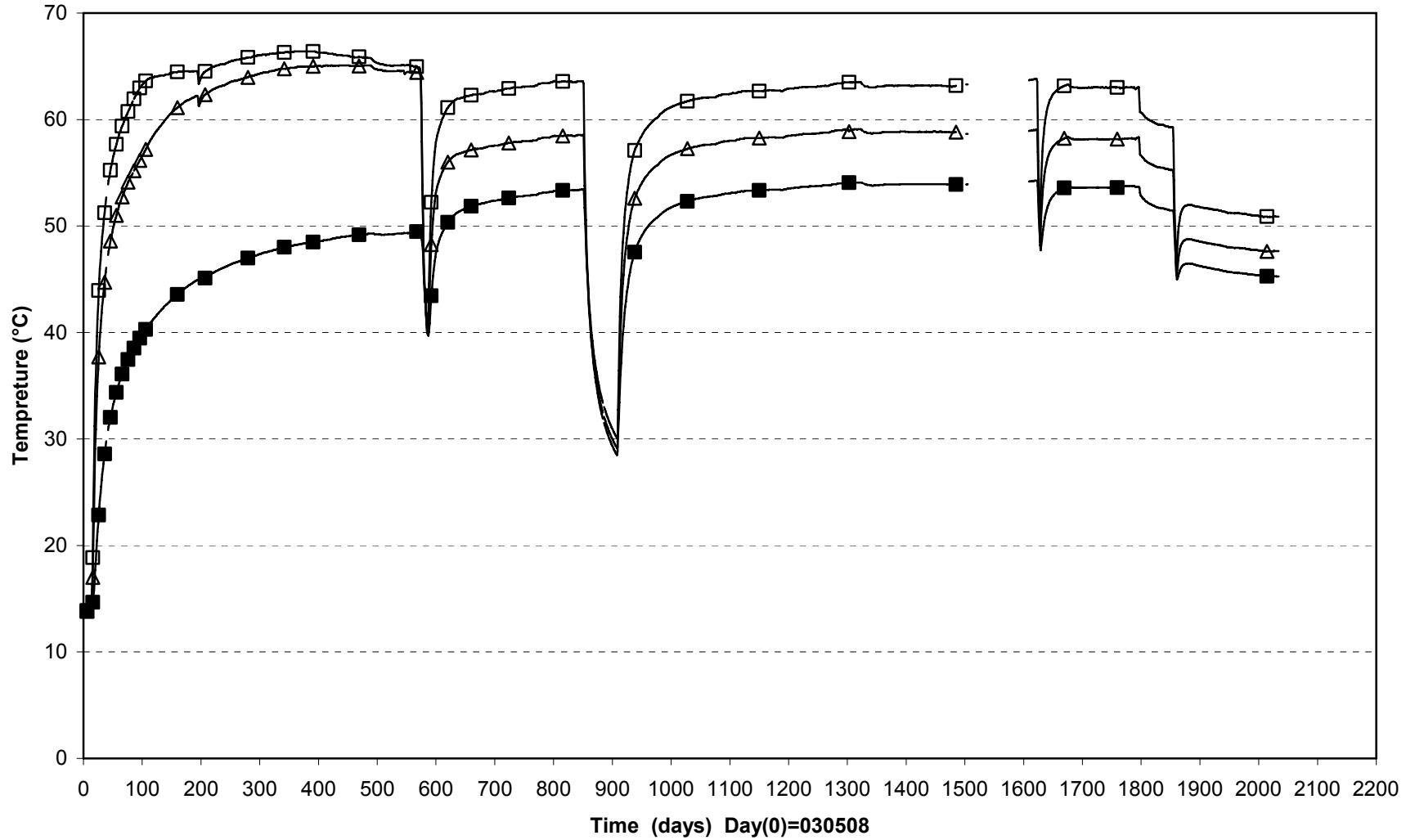

△ PB613T(3.550\55°\0.785)
□ PB614T(3.550\145°\0.635)
■ PB616T(3.253\325°\0.875)

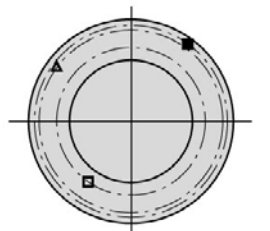
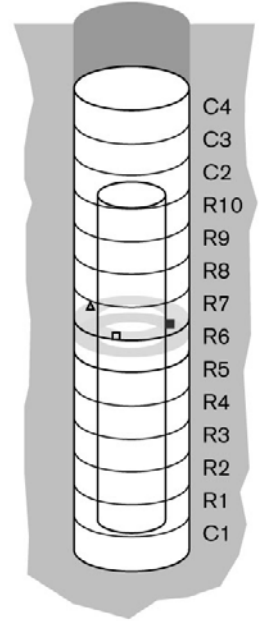
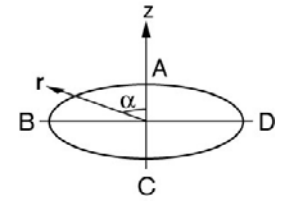

Prototype\Hole 6\ Ring9 (030508-081201)
 Temperature - Geokon

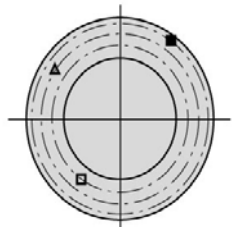
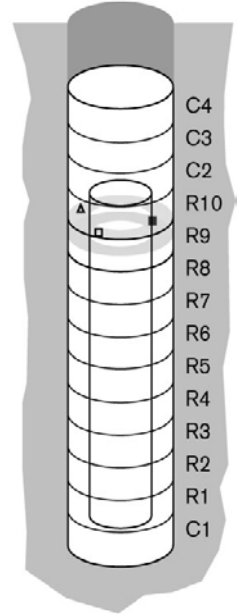
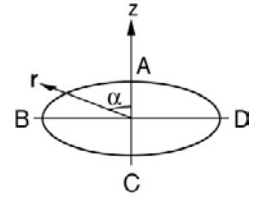
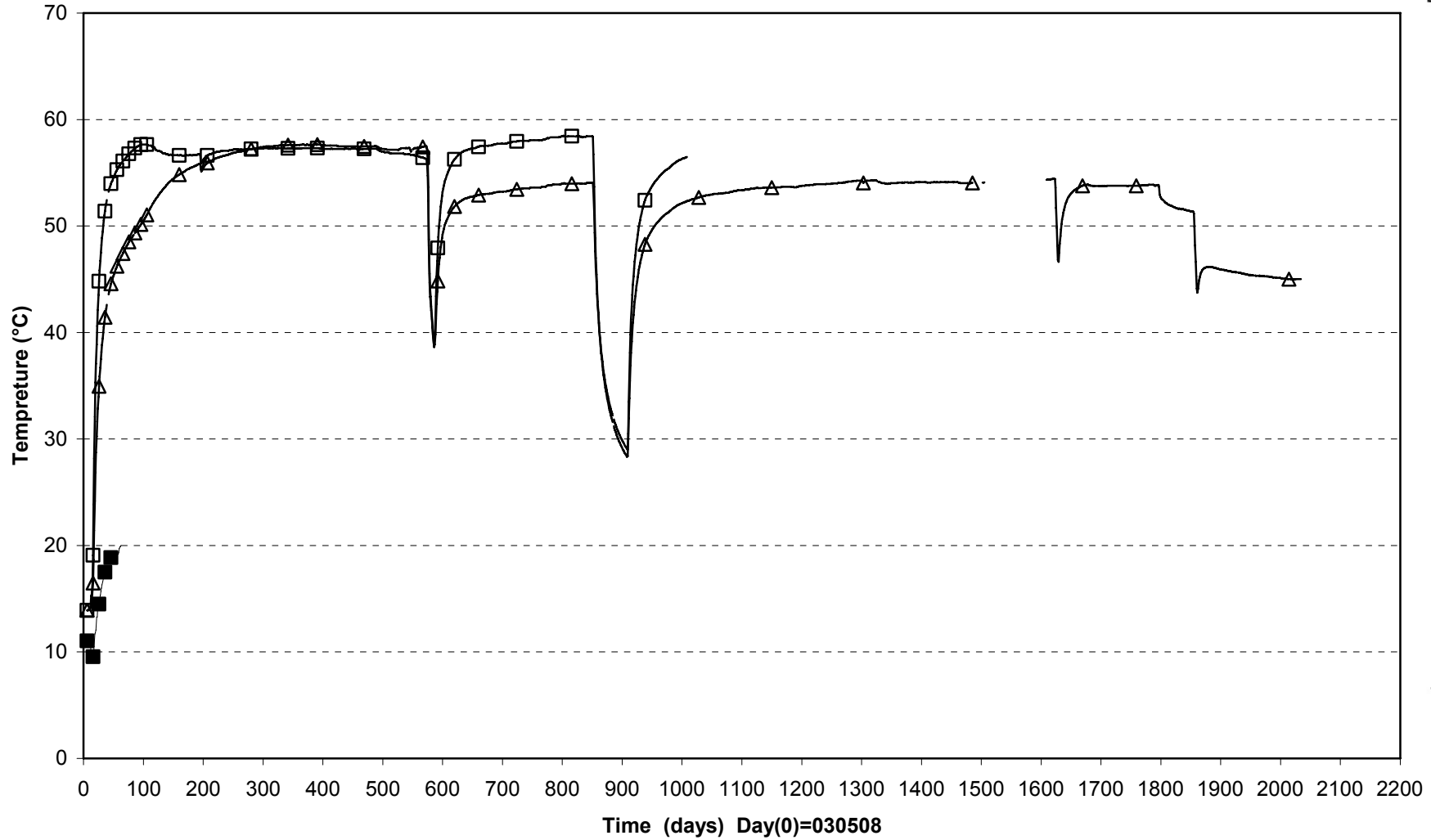

△ PB620T(5.084\55°\0.735)
□ PB621T(5.084\145°\0.635)
■ PB623T(4.753\325°\0.875)

Prototype\Hole 6\Cyl.3 and Cyl.4 (030508-081201)
 Temperature - Geokon

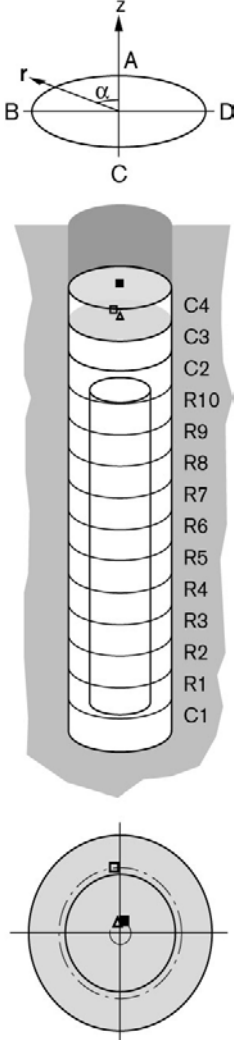
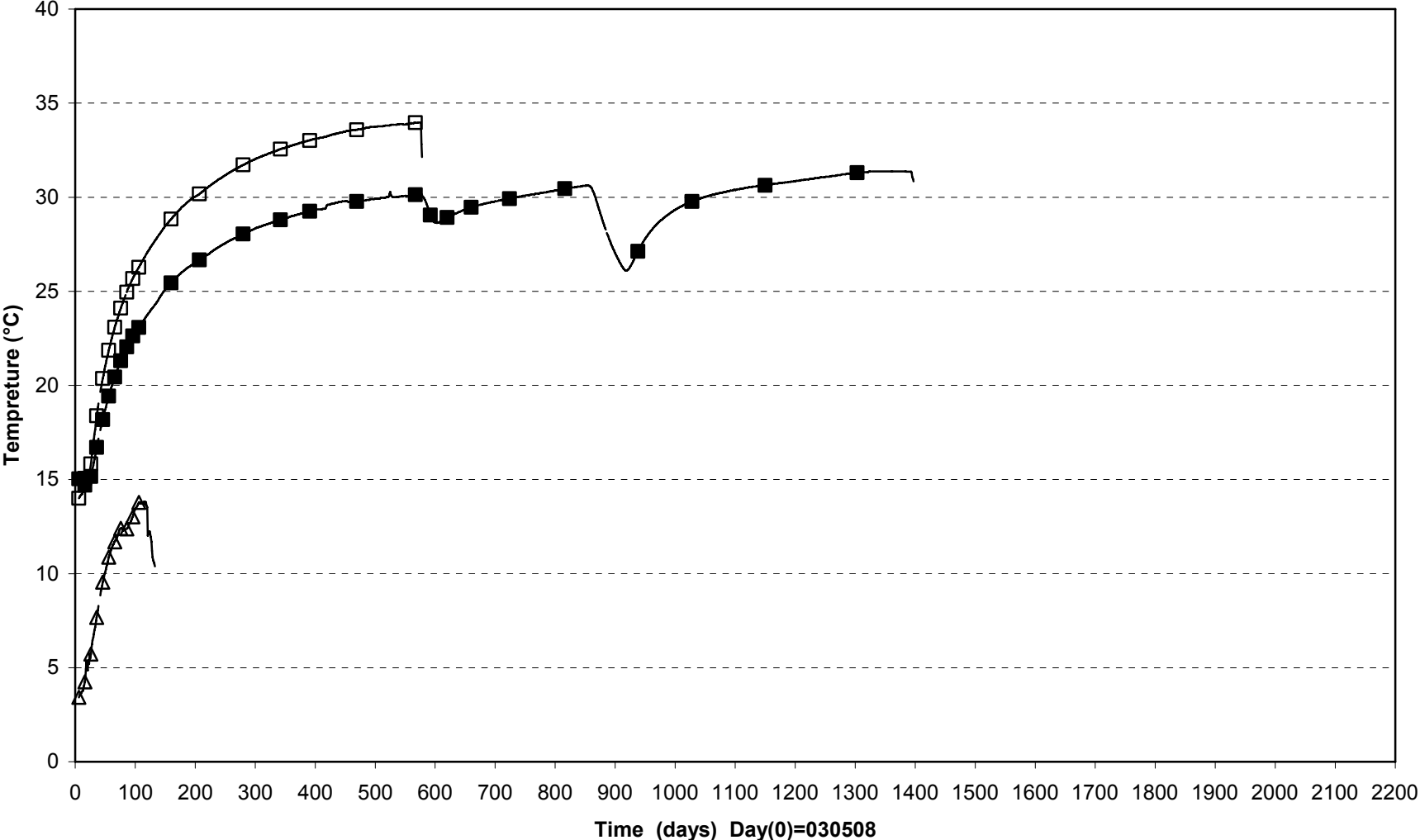

△PB625T(6.616\0°\0.100)

□PB626T(6.616\5°\0.585)

■PB627T(7.121\0°\0.100)

Prototype\Hole6 (030508-081201)
Temperature- Geokon

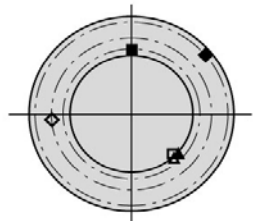
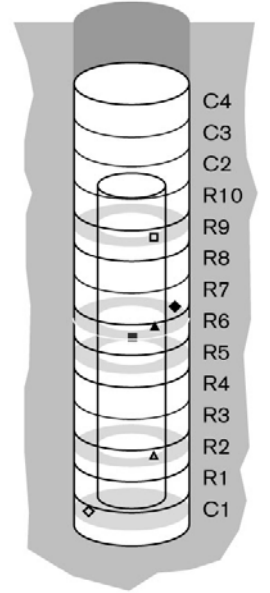
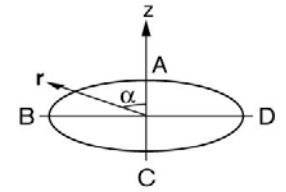
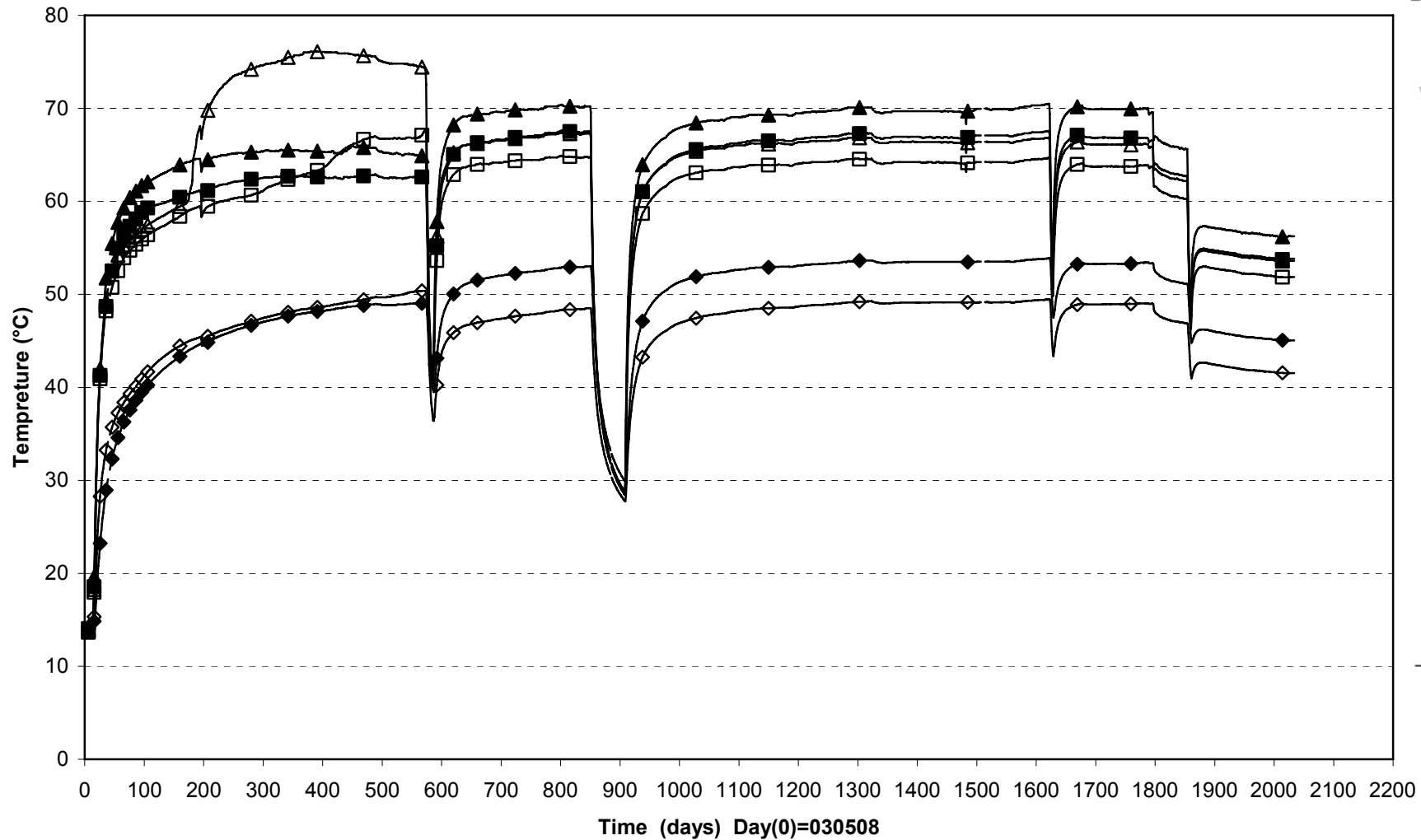

◇ UB602T(0.260\95°\0.685)	△ UB603T(1.284\225°\0.535)	■ UB605T(2.795\190°\0.585)
▲ UB609T(3.300\225°\0.535)	◆ UB610T(3.253\310°\0.875)	□ UB611T(4.834\225°\0.535)

Prototype\ Hole 6 \ Cyl1 (030508-081201)
 Temperature - Wescor

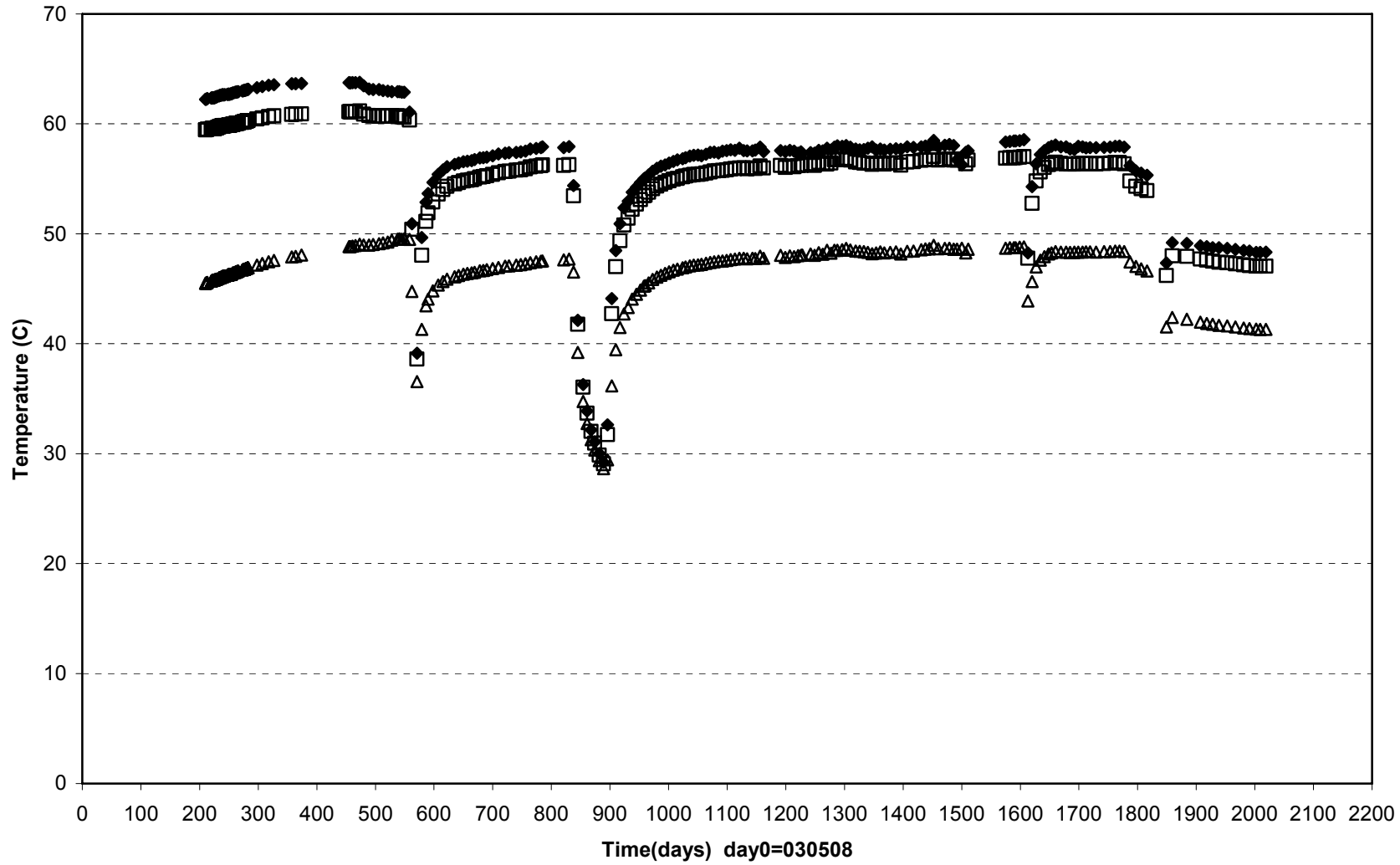

□ WB602T(0.260\225°\0.050) ♦ WB603T(0.260\260°\0.210) △ WB605T(0.260\90°\0.685)

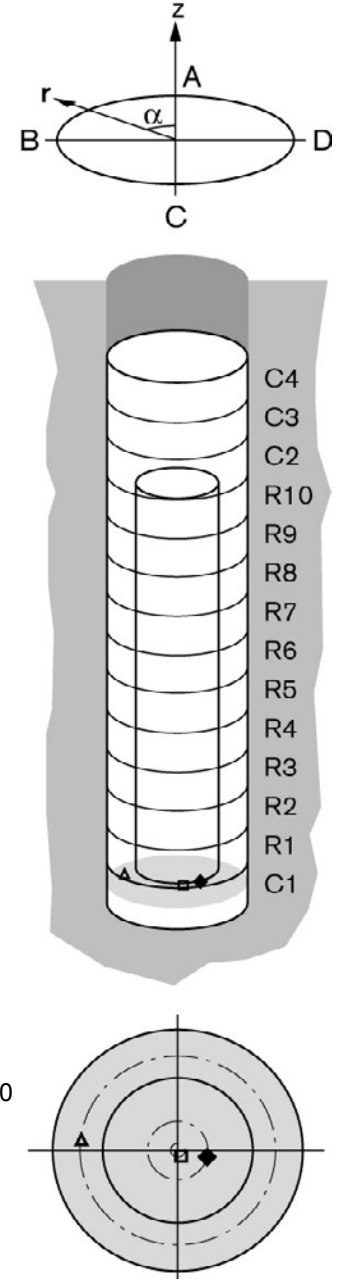

Prototype\ Hole 6 \ Ring 1 and Ring 2 (030508-081201)
 Temperature - Wescor

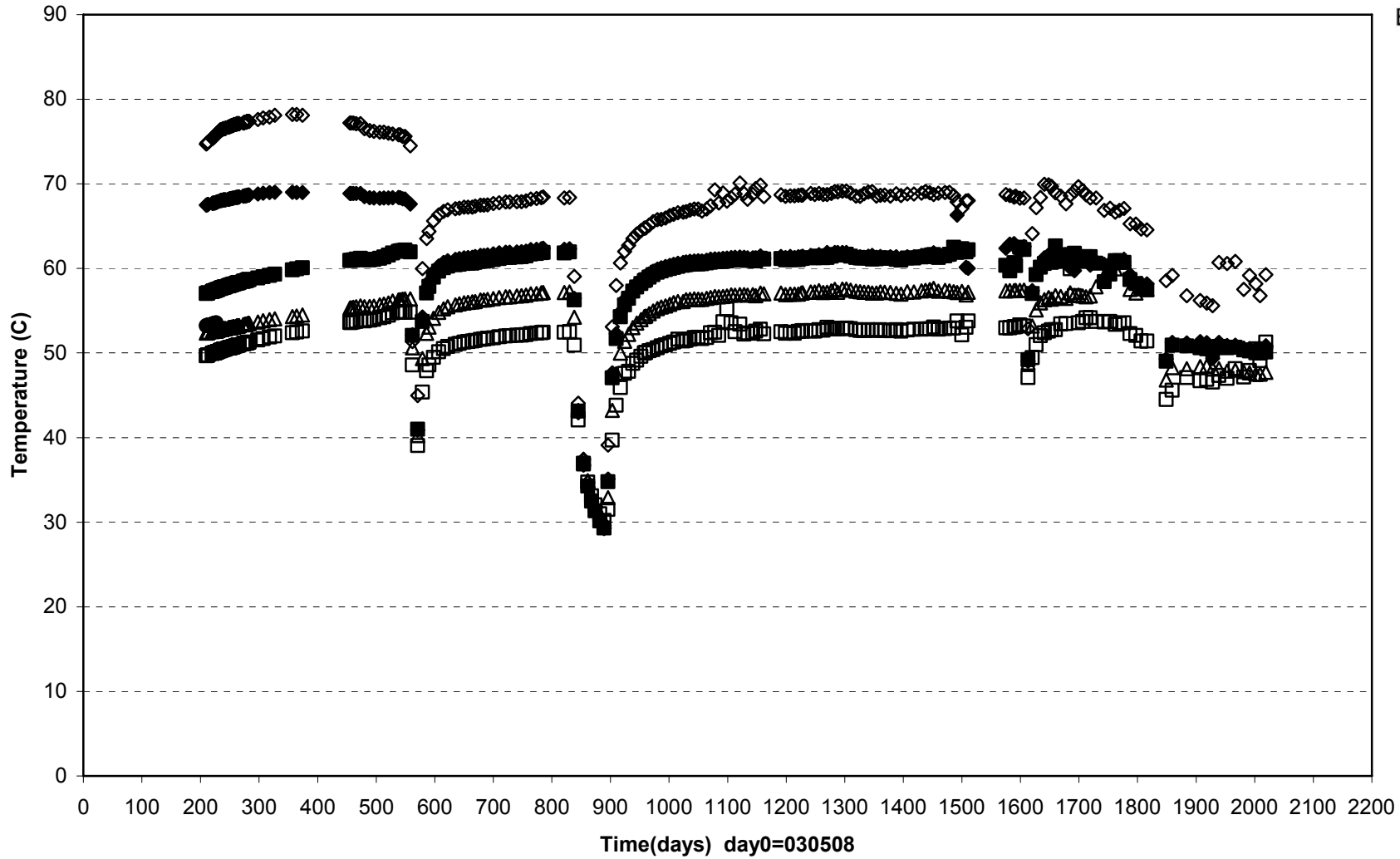

- WB608T(0.770\95°\0.685) ◆ WB612T(0.750\185°\0.585) □ WB611T(0.770\355°\0.785)
- △ WB614T(1.284\45°\0.735) ■ WB616T(1.284\135°\0.635) ◇ WB618T(1.284\235°\0.535)

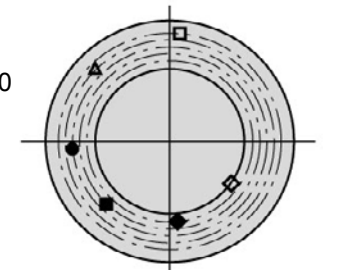
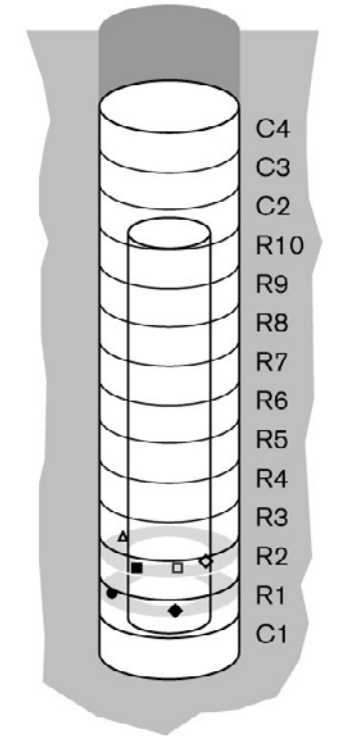
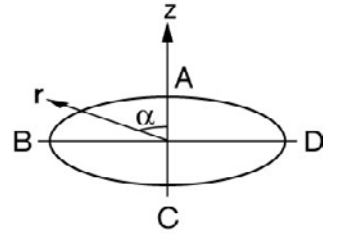

Prototype\ Hole 6 \ Ring 5 and Ring 6 (030508-081201)
 Temperature - Wescor

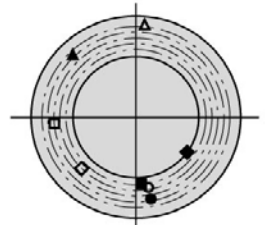
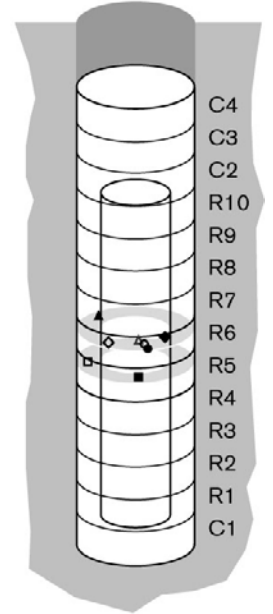
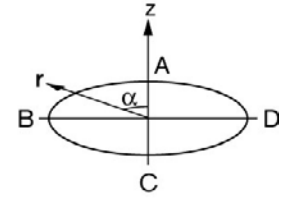
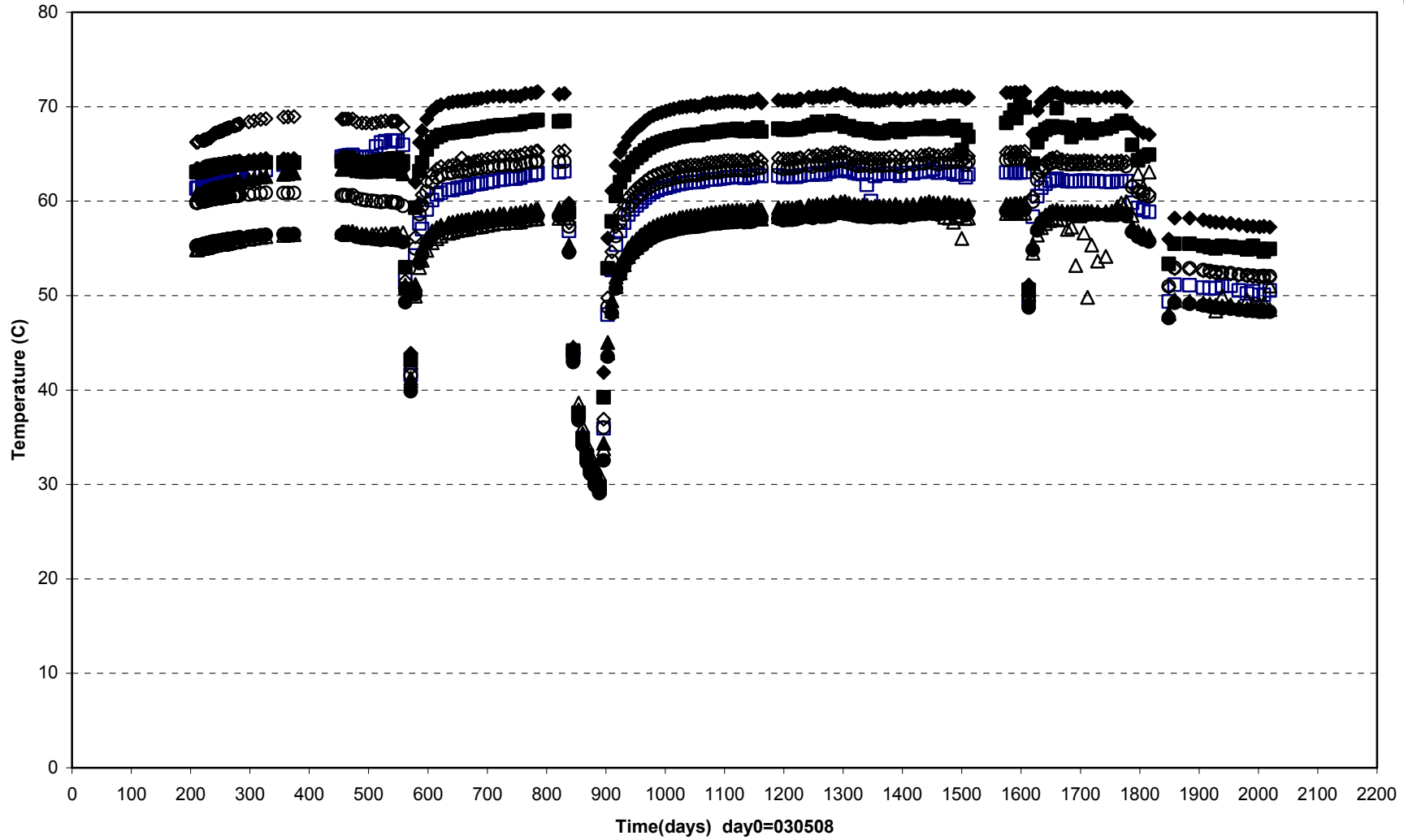

- WB622T(2.795\95°\0.685) ■ WB624T(2.795\185°\0.585) △ WB625T(2.795\355°\0.785) ▲ WB628T(3.300\45°\0.735)
- ◇ WB630T(3.300\135°\0.635) ◆ WB632T(3.300\235°\0.535) ○ WB657T(3.300\190°\0.625) ● WB658T(3.300\190°\0.725)

Prototype\ Hole 6 \ Ring 6 and Ring 8 (030508-081201)
 Temperature - Wescor

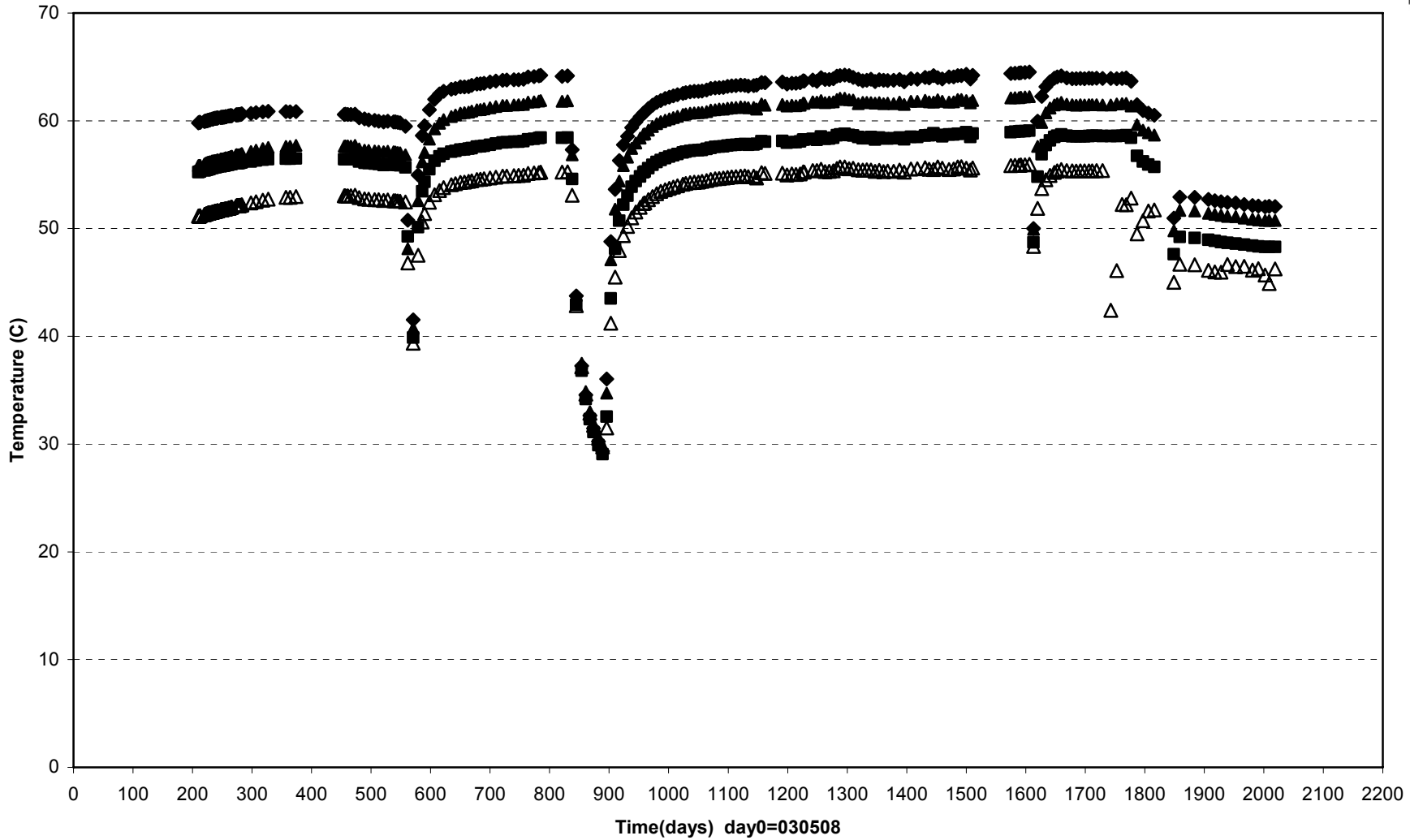

◆ WB657T(3.300\190°\0.625) ■ WB658T(3.300\190°\0.725) ▲ WB662T(4.324\280°\0.625) △ WB663T(4.324\280°\0.725)

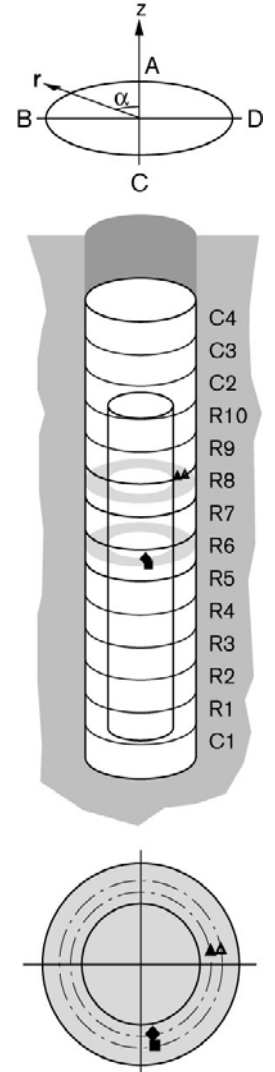

Prototype\ Hole 6 \ Ring 8 and Ring 9 (030508-081201)
 Temperature - Wescor

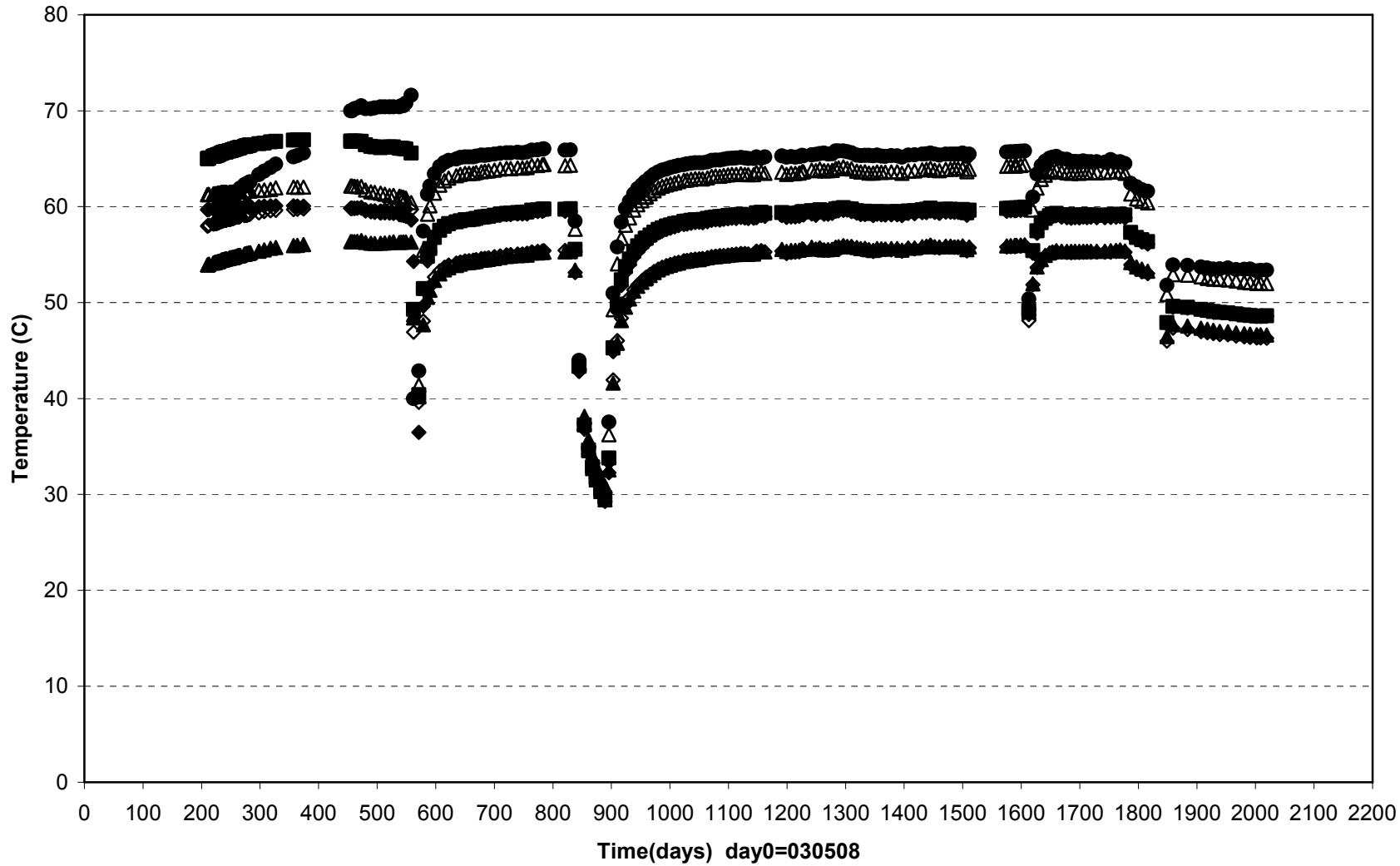

- WB636T(4.324\95°\0.685) △ WB638T(4.324\185°\0.585) ▲ WB639T(4.324\355°\0.785)
- ◇ WB642T(4.834\45°\0.735) ◆ WB644T(4.834\135°\0.635) ● WB646T(4.834\235°\0.535)

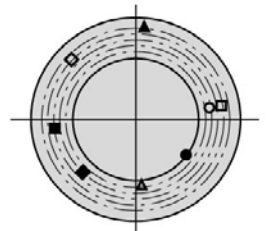
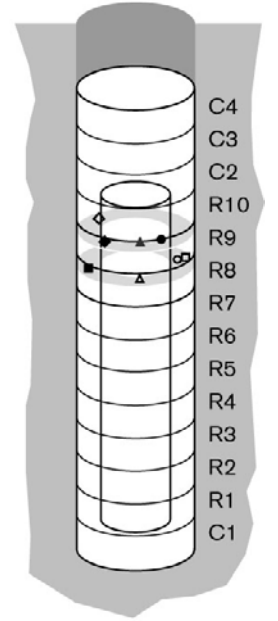
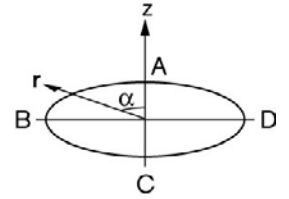

Prototype\Rock\Hole 6\ Level bottom (030508-081201)
 Temperature - Pentronic

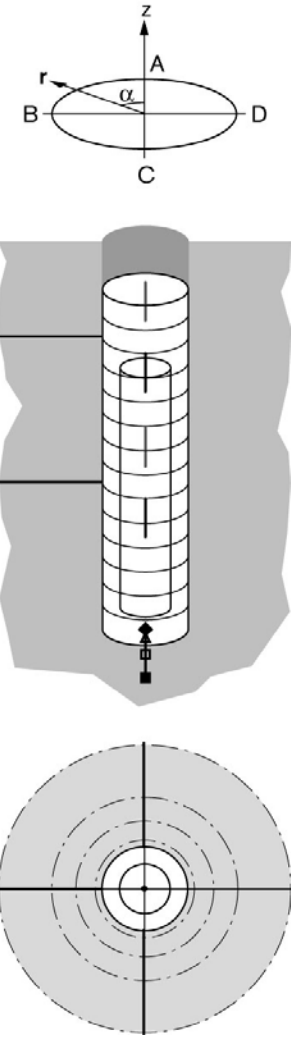
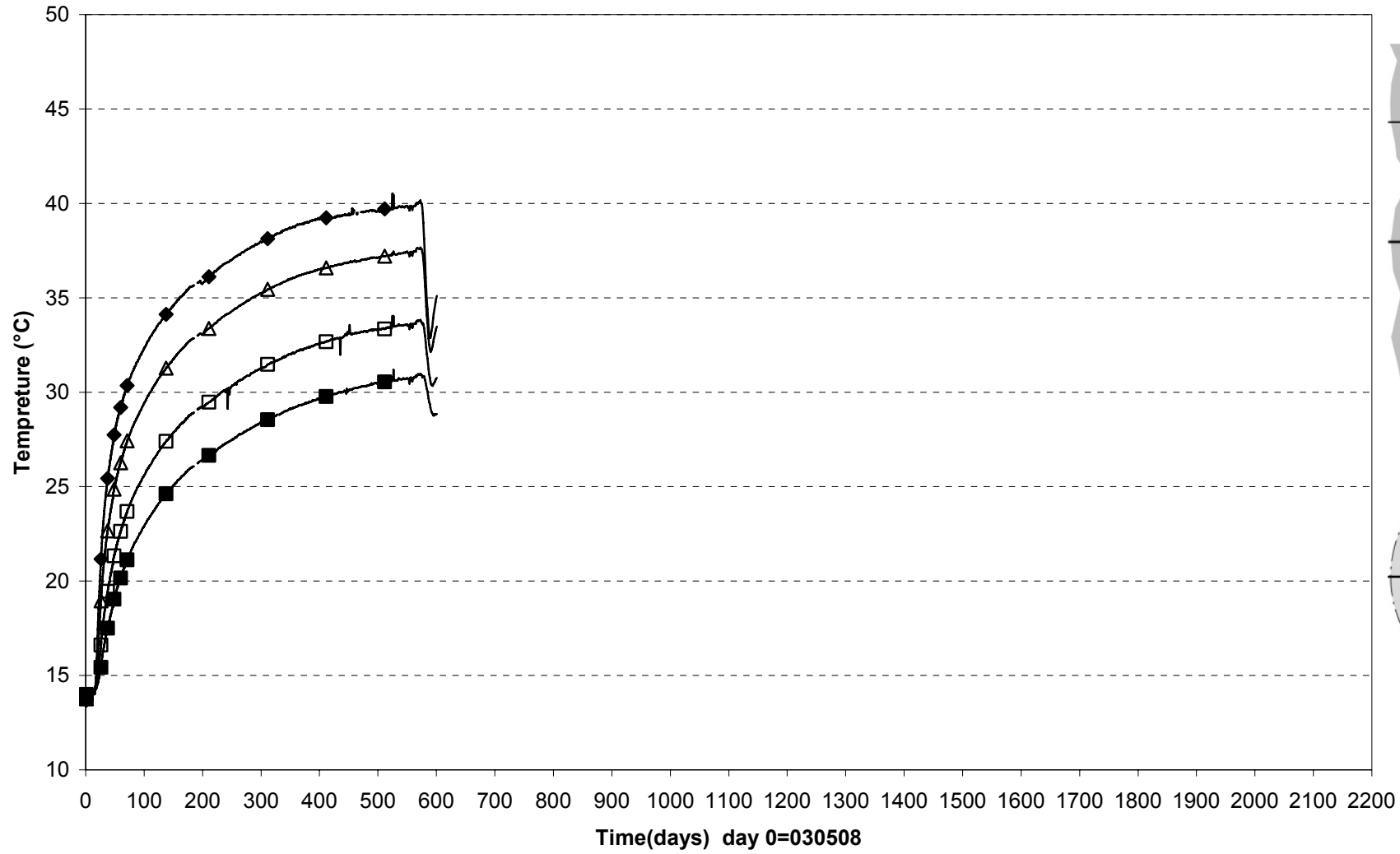

■ TR6011(-1.00°\ 0.0) □ TR6012(-0.50°\ 0.0) △ TR6013(-0.20°\ 0.0) ◆ TR6014(0.0\0°\ 0.0)

Prototype\Rock\Hole 6 \ Level 3,0 m (030508-081201)
 Temperature - Pentronic

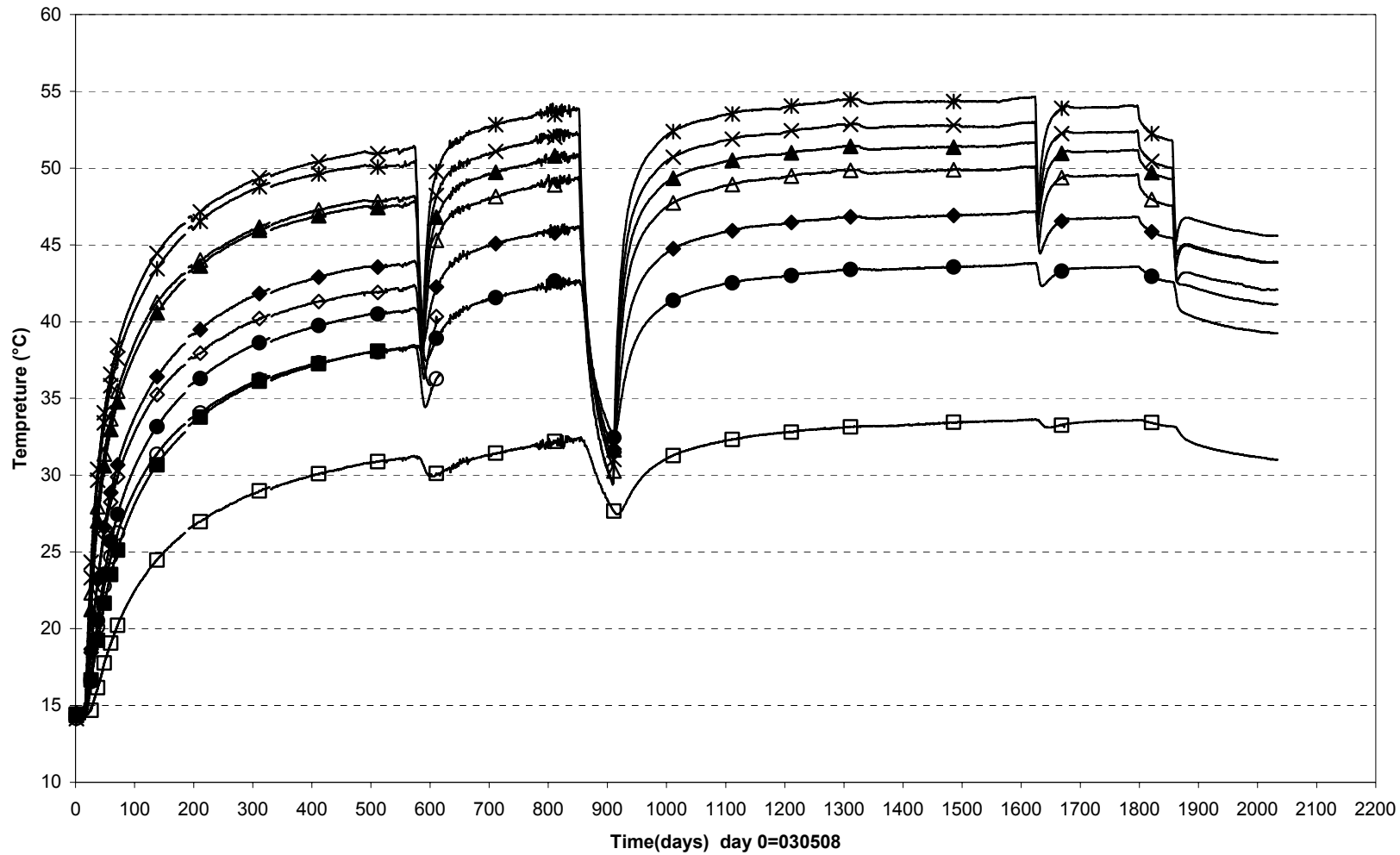

- TR6041(3.0\79°\ 3.075) ○ TR6042(3.0\79°\ 1.975) ◇ TR6043(3.0\79°\ 1.475) △ TR6044(3.0\79°\ 1.075) × TR6045(3.0\79°\ 0.875)
- TR6051(3.0\347°\3.075) ● TR6052(3.0\347°\1.975) ◆ TR6053(3.0\347°\1.475) ▲ TR6054(3.0\347°\1.075) ✱ TR6055(3.0\347°\0.875)

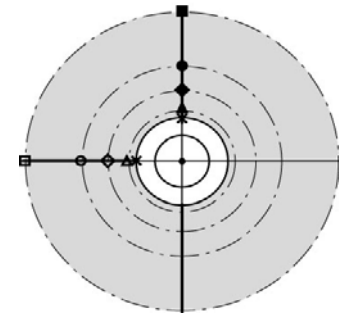
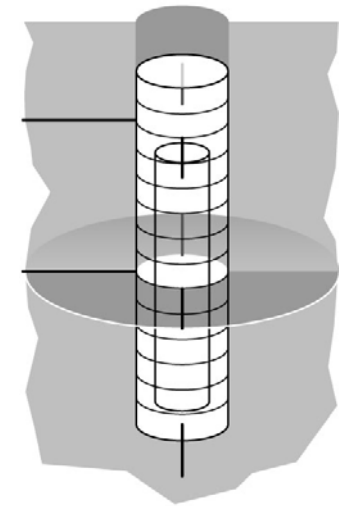
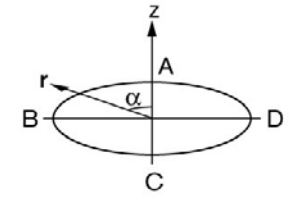

Prototype\Rock\Hole 6\ Level 6,0 m (030508-081201)
 Temperature - Pentronic

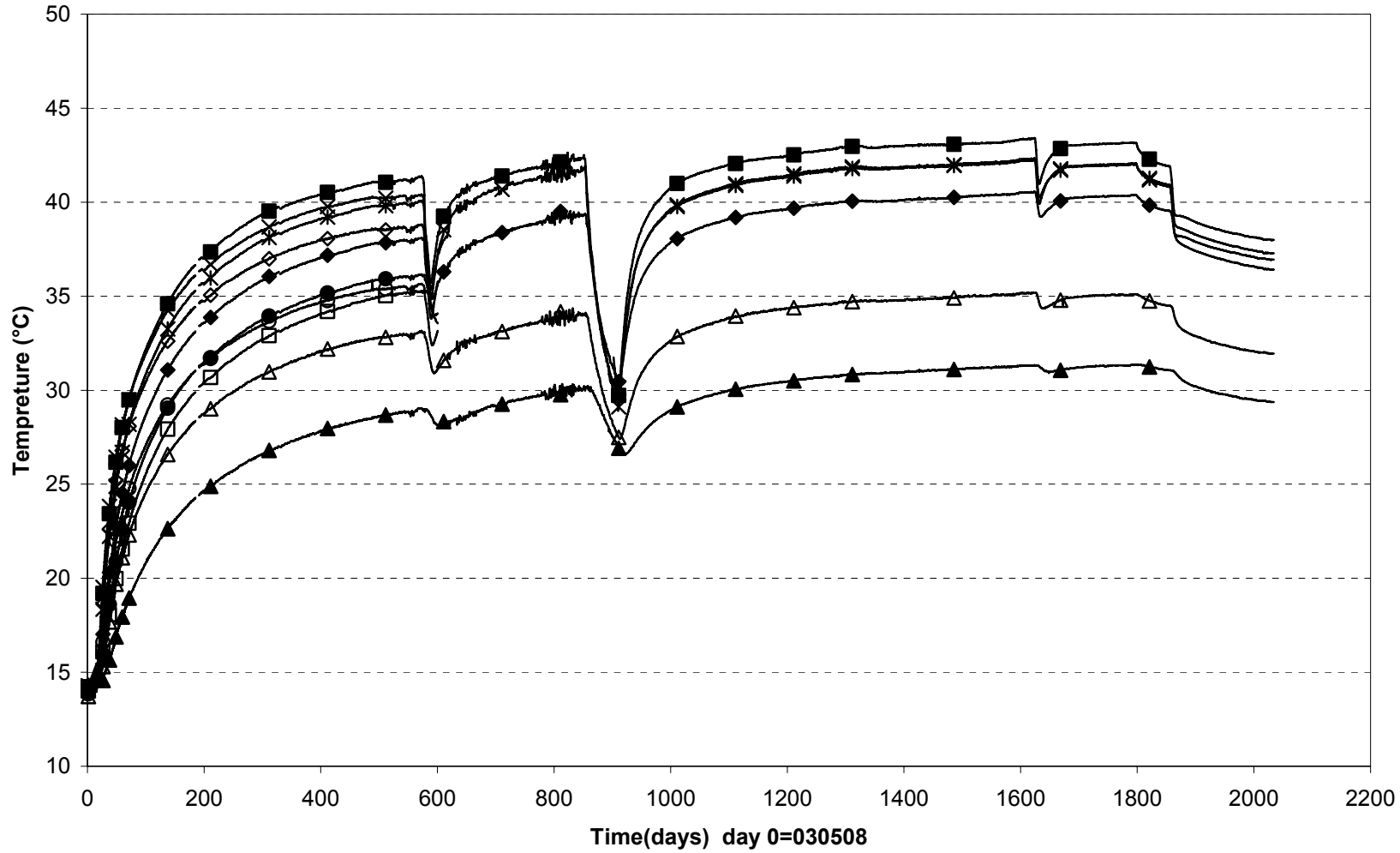

- | | | | | |
|---------------------------|---------------------------|---------------------------|---------------------------|---------------------------|
| ▲ TR6021(6.0\79°\ 3.075) | △ TR6022(6.0\79°\ 1.975) | ○ TR6023(6.0\79°\ 1.475) | ◇ TR6024(6.0\79°\ 1.075) | × TR6025(6.0\79°\ 0.875) |
| □ TR6031(6.0\349°\ 3.075) | ● TR6032(6.0\349°\ 1.975) | ◆ TR6033(6.0\349°\ 1.475) | ✱ TR6034(6.0\349°\ 1.075) | ■ TR6035(6.0\349°\ 0.875) |

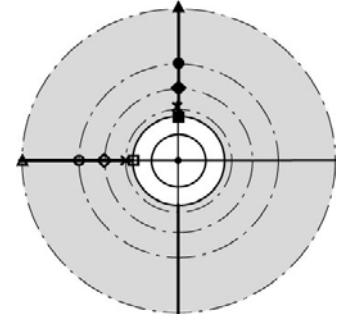
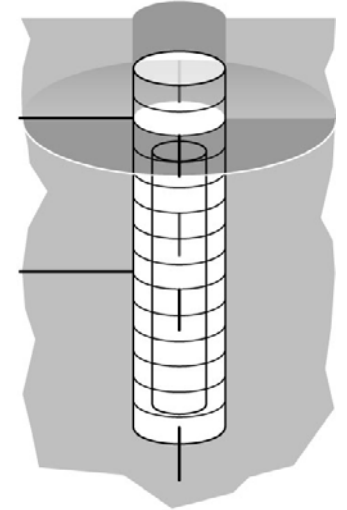
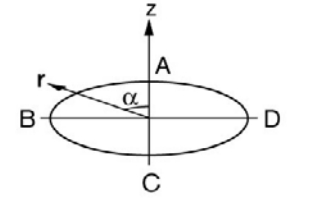

Prototype\Hole 6 (030508-081201)
Canister power

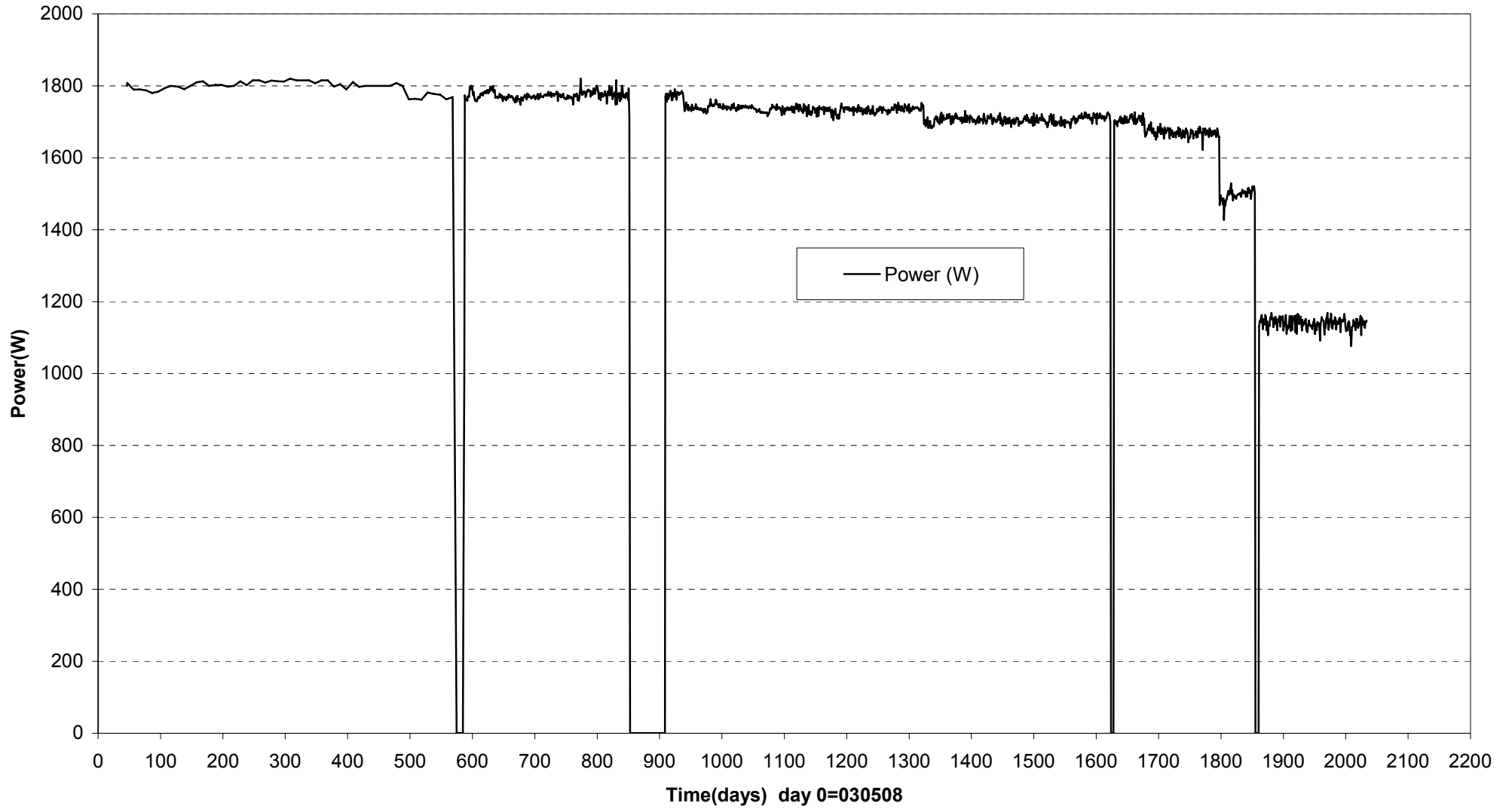

Prototype\ Hole 6 \Canister (030508-070601)
 Max. temperature on the canister surface - Optical fiber cables

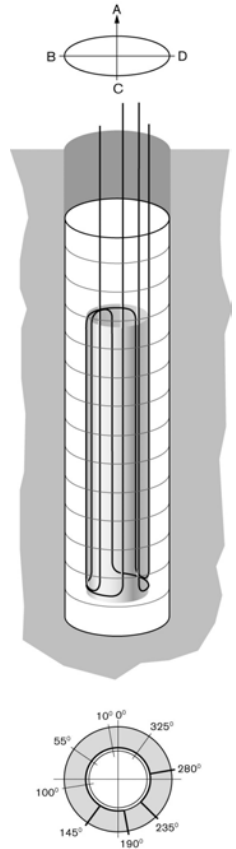
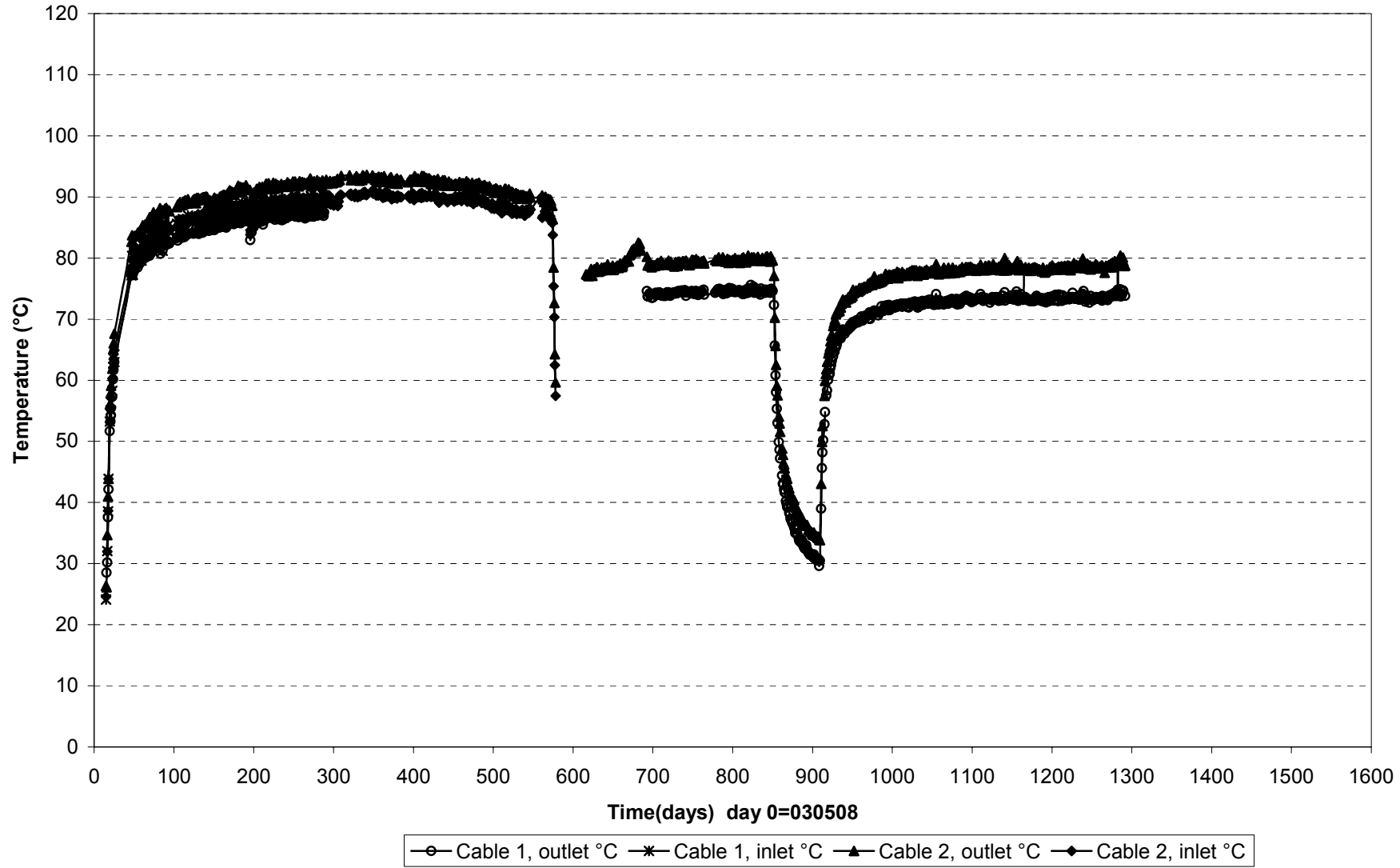

**Temperature profile on the canister surface-No6 (061119)
Optical fiber cables**

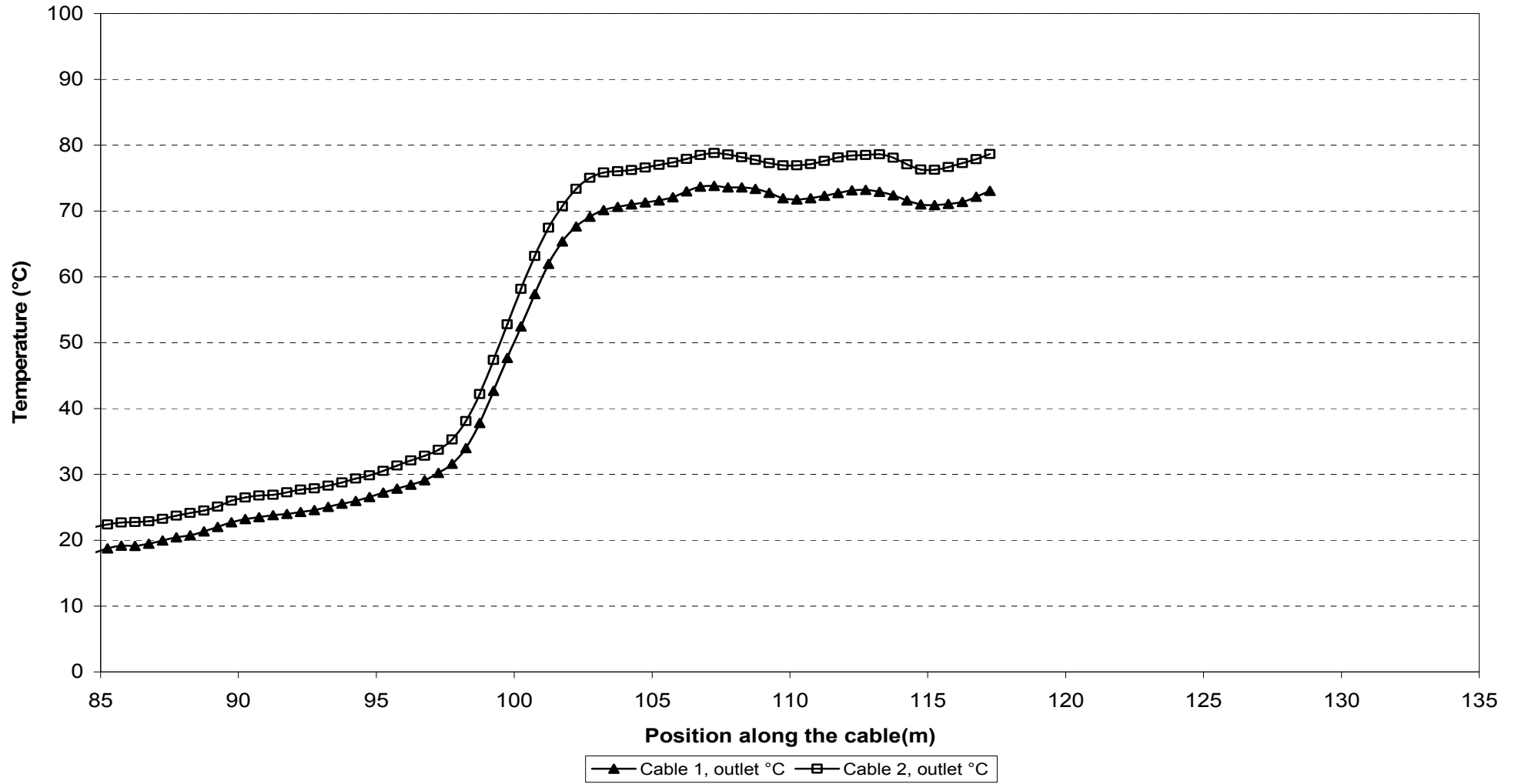

Prototype\Hole 6 \On the canister surface (030508-081201)
 Temperature - Pentronic

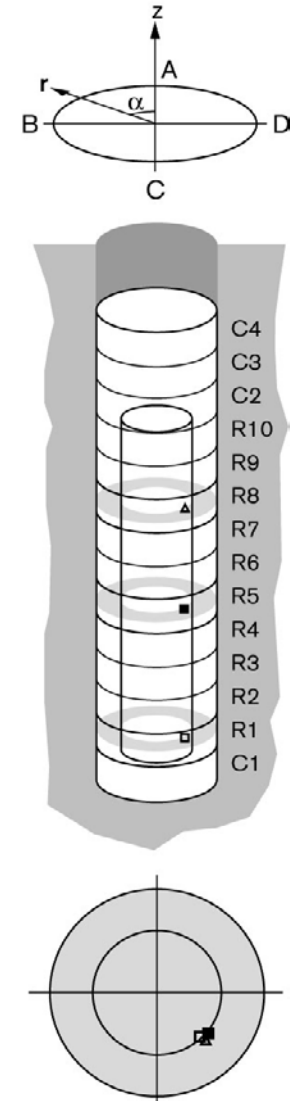
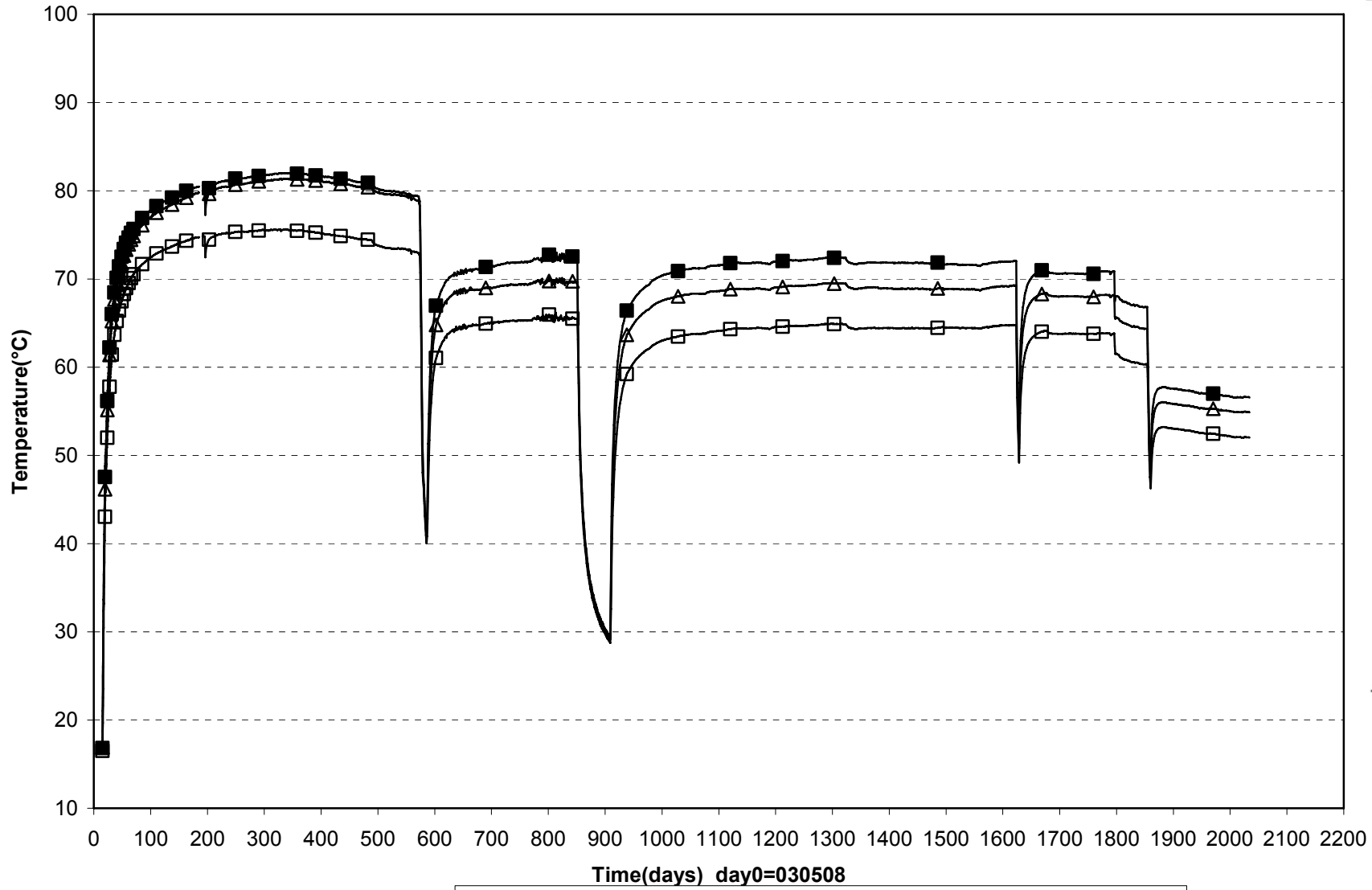

□ TB611(0.753\ 0°\0.525) ■ TB619(2.753\ 0°\0.525) △ TB627(4.253\0°\0.525)