

International
Progress Report

IPR-01-18

Äspö Hard Rock Laboratory

Prototype Repository

Detailed design of lead throughs and cable protections in the Prototype Repository, Section I

Torbjörn Sandén

Clay Technology AB

May 2001

Svensk Kärnbränslehantering AB

Swedish Nuclear Fuel
and Waste Management Co
Box 5864
SE-102 40 Stockholm Sweden
Tel +46 8 459 84 00
Fax +46 8 661 57 19



Äspö Hard Rock
Laboratory

Report no.
IPR-01-18

Author
T Sandén

Checked by
Christer Svemar

Approved
Christer Svemar

No.
F63K
Date
01-05-02

Date

Date
01-07-03

Äspö Hard Rock Laboratory

Prototype Repository

Detailed design of lead throughs and cable protections in the Prototype Repository, Section I

Torbjörn Sandén

Clay Technology AB

May 2001

Keywords: Prototype Repository, lead throughs, cable protection

This report concerns a study which was conducted for SKB. The conclusions and viewpoints presented in the report are those of the author(s) and do not necessarily coincide with those of the client.

Abstract

SKB will build a full-scale model of the deep repository planned for disposal of spent nuclear fuel from the Swedish nuclear program. The Prototype Repository will be constructed in the Äspö Hard Rock Laboratory and located at 450 m depth below the ground surface. The prototype will include six deposition holes in which full size canisters with electrical heaters will be placed and surrounded by bentonite. The deposition tunnel will be backfilled with a mixture of bentonite and crushed rock.

This report describes how tubes and cables from instruments in bentonite, backfill and rock will be led through the rock to an adjacent tunnel. The demands on the lead through are very high when it comes to tightness, strength and durability. The principle are that all cables and tubes will be led through a steel flange and then further through a steel pipe which is placed in a bore hole through the rock. The sealing of the cables and tubes through the flange will mainly be done with ferrule connections of Swagelok type. To some of the cables, for example the power cables to the heaters, special lead throughs of submarine type will be manufactured. The space between the steel tubes, leading cables and tubes, and the rock will be sealed with special manufactured bentonite rings at a length of about 1 meter closest to the test area and 1 meter closest to the outlet of the tube. The bentonite will be supported by steel flanges and rubber sealing and if necessary also with cement plugs. The rest of the length will be grouted with cement. Totally 27 bore holes will be needed in order to lead about 1000 cables and tubes out from the test site.

Sammanfattning

SKB kommer att uppföra en fullskalemodell av det djupförvar som planeras för slutförvaring av utbränt kärnbränsle från det svenska kärnkraftsprogrammet. Prototypförvaret kommer att byggas i Äspö Hard Rock Laboratory på ca 450 meters djup. Det kommer att bestå av sex deponeringshål i vilka fullskaliga kopparkapslar med elektriska värmare kommer att placeras och omges av högkompakterad bentonit. Deponeringstunnlarna kommer att återfyllas med en blandning av bentonit och krossat berg.

Denna rapport beskriver hur rör och kablar från instrument i bentonit, backfill och berg skall dras genom berget och ut till en angränsande tunnel. Höga krav ställs på genomföringarna vad gäller täthet, hållfasthet och beständighet. Principen för genomföringarna är att alla kablar och rör skall passera en fläns av stål och sedan ledas vidare genom ett stålrör som går genom berget. Tätningen av kablarna och rören genom stålet kommer huvudsakligen att ske med hjälp av skärringskopplingar av Swagelok-typ. I en del fall tex. vad gäller de grövre elkablarna till värmarna kommer speciella genomföringar av ubåtstyp att användas. Utrymmet mellan stålrören, som leder alla kablar och rör, och berget skall tätas med specialtillverkade bentonitringar på en sträcka om ca 1m närmast testorten samt 1m närmast utgången till angränsande tunnel. Bentoniten kommer att hållas på plats med hjälp av påsvetsade stödringar samt gummipackningar. Eventuellt kommer även betong- pluggar att gjutas som stöd. Resten av sträckan kommer att tätas med injekterad cement. Totalt behövs 27 borrhål för ca 1000 kablar och rör.

Table of contents

Abstract.....	2
Sammanfattning.....	3
Table of contents	4
List of Tables.....	5
List of Figures.....	5
List of Appendices.....	6
1. Introduction	7
2. Prototype Repository.....	9
3. Handling and protection of the different cable types.....	10
3.1 Cables from canister.....	11
3.2 Cables from buffer	13
3.3 Cables from backfill.....	16
3.4 Cables from rock.....	18
4. Design of cable parcels	19
4.1 Quantity and distribution of cables and tubes.....	19
4.2 Principal design of flanges.....	20
5. Assembling of cable parcels	22
5.1 Parcels including cables from canister.....	22
5.2 Parcels including cables from buffer, backfill and rock	22
6. Installation of cable parcels.....	24
7. References.....	25

List of Tables

Table 3.1 Table showing the distribution of cables and tubes in the lead throughs at the four inner deposition holes.	22
---	----

List of Figures

Figure 1-1 Schematic view over a lead through.	9
Figure 3-1 Schematic view showing how the polyamide tubes are sealed when passing through the head flanges	13

List of Appendices

1. Vessel containing Vaisala electronics
2. Vaisala titanium protection
3. Rotronic titanium protection
4. Wescor titanium protection
5. Technical drawing of Flange LT11
6. Technical drawing of Flange LT12
7. Technical drawing of Flange LT13
8. Technical drawing of Flange LT14
9. Technical drawing of Flange LT21
10. Technical drawing of Flange LT22
11. Technical drawing of Flange LT23
12. Technical drawing of Flange LT24
13. Technical drawing of Flange LT31
14. Technical drawing of Flange LT32
15. Technical drawing of Flange LT33
16. Technical drawing of Flange LT34
17. Technical drawing of Flange LT41
18. Technical drawing of Flange LT42
19. Technical drawing of Flange LT43
20. Technical drawing of Flange LT44
21. Pressure Hull Penetration

1. Introduction

SKB will build a full-scale model of the deep repository planned for disposal of spent nuclear fuel from the Swedish nuclear program. This Prototype Repository will be built at the Äspö Hard Rock Laboratory and located at 450 m depth below the ground surface. The prototype will include six deposition holes in which full size canisters with electrical heaters will be placed and surrounded by bentonite. The deposition tunnel will be backfilled with a mixture of bentonite and crushed rock.

Instruments of different types will be placed in the bentonite, in the backfill material, on the canister and in the surrounding rock. Cables and tubes from the transducers will be led through the rock in to the adjacent tunnel (the G-tunnel) and then further to a measuring container. This report deals with the design (cable protection and distribution) of the cables in order to make a secure sealing on their way from the test area into the adjacent tunnel and the cable protection in the test area. The design of the lead through with tubes through the rock, sealing of bentonite and cement (see Figure 1-1), is treated in another report, Principal design of lead throughs and cable protection in the Prototype Repository.

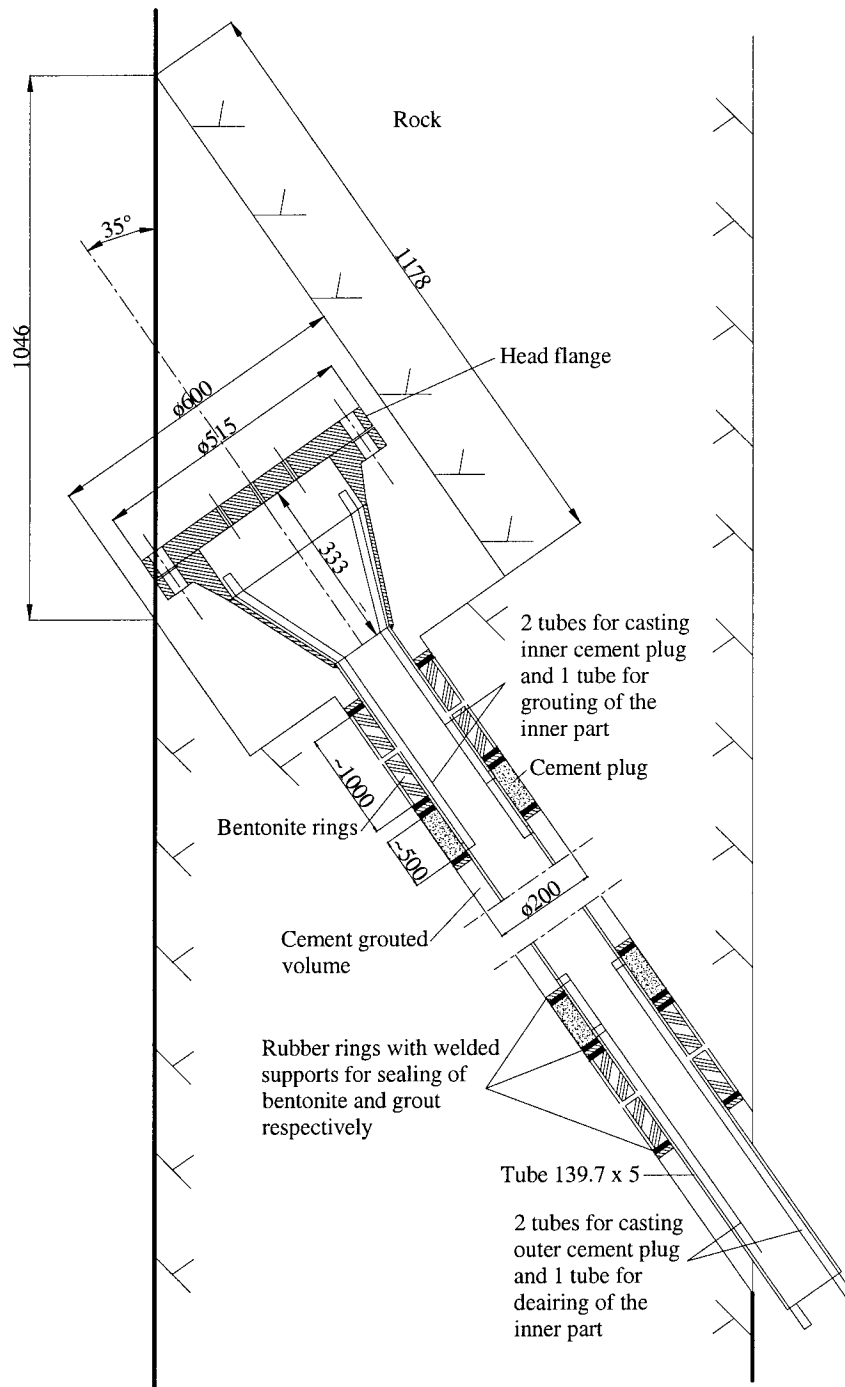

Figure 1-1 Schematic view over a lead through. Sixteen lead-throughs are needed for the inner section and eleven for the outer section.

2. Prototype Repository

The Prototype Repository is described in the test plan /2-1/. The test is located in the innermost part of the TBM-tunnel. The test consists of six full scale deposition holes, copper canisters equipped with electrical heaters, bentonite blocks (cylindrical and ring shaped) and a deposition tunnel backfilled with a mixture of bentonite and crushed rock. Different types of measurements will be done in the test volume:

1. The canisters will be equipped with electrical heaters. The temperature will be measured on the canister's surface. Movements of one of the canisters will also be measured.
2. The hydraulic water pressure will be measured in the rock in several points. Other measurements in the rock are: rock stresses, acoustic emission and resistivity.
3. The bentonite and the backfill will be instrumented with pressure cells (total and water pressure), thermocouples and moisture gauges.
4. Equipment for sampling of gas and water will also be installed.

The different instrument types are described in a special report /2-2/. The exactly positions and cable lengths will be described in a later report /2-3/.

3. Handling and protection of the different cable types

The cables and tubes will be handled in different ways depending on type, function and material.

Five types of tubes/cables will pass through the bore-holes:

- Hydraulic tubes. These tubes are made of polyamid and will be leading water from the rock to gauges placed in the G-tunnel.
- The tubes for chemical sampling are made of PEEK.
- Electrical signals in cables. The cables will be led in polyamide tubes in order to protect them mechanically and in order to make a secure sealing through the flanges. All gauges and cables placed in the bentonite, will be protected by titanium tubes. The gauges measuring relative humidity are built in to special designed cases, Appendix 7 and 8. When the titanium tube enters the backfill material there will be a change of material to polyamide. It is important that the connection of the outer protection tubes to the gauges are tight in order not to lead water inside the protection tube.
- Thermocouples. The thermocouples are made of cupronickel. They do not need any additional protection.
- Multi-wire cables. The power cables and the cable from the resistivity measurement are made of polyether-polyurethane reinforced with kevlar. They do not need any additional protection.
- Optic fiber cables. The optic fiber is protected by inconel tubes with a diameter of 2mm.

3.1 Cables from canister

3.1.1 Power cables

The power cables, three to each canister, are made of polyether-polyurethane. The cable itself does not need any additional protection. A so called PHP (Pressure Hull Penetration) will in advance be mounted on the cable a set distance from the canister. PHP devices are currently used in both submarines and oil platforms. The device consists of a house and flange of stainless steel and on the high pressure side there is a moulding around the cable. The system permits that different qualities of multi cables can be used on the high pressure side and the low pressure side respectively.

The cable mounted on the low pressure side will be thread through the head flange until the PHP is reached. This will then be fastened on the head flange (Appendix 21).

3.1.2 Temperature by optic fiber

The temperature will be measured on the surface of all canisters. This will be done by a fiber optic based measurement. Fiber optic cables, protected by tubes of inconel with an outer diameter of 2 mm will be countersunk on the copper surface in two loops. The tubes are mounted on the canisters at delivery. This means that the tubes must be pulled through the head flanges a distance of about 100 m. The tubes are sealed on their passage through the flanges by use of Swagelok ferrule connections, Figure 3-1.

3.1.3 Canister displacement

Aitimin is responsible for this measurement. Six displacement sensors, grouped in two measuring sections, will be placed in two horizontal planes on top and bottom of the canister respectively. The sensors are fiber optic based. The fiber optic cables are protected by inconel tubes. The tubes will be handled in the same way as the optic fiber cable measuring temperature on the canister surface.

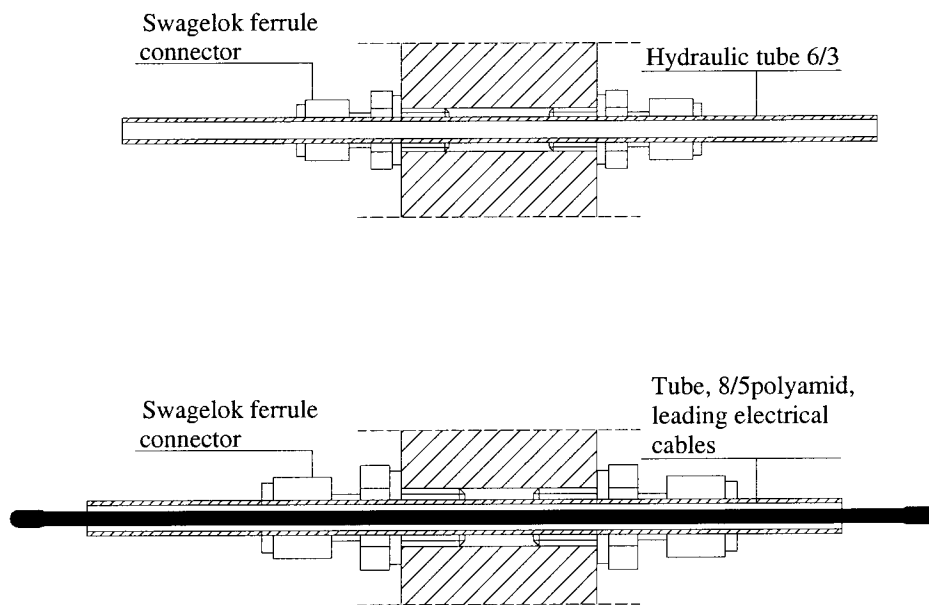

Figure 3-1 Schematic view showing examples over how the polyamid tubes are sealed when passing through the head flanges. The examples are also valid for tubes of other material i.e. inconel tubes leading fiber optic cables or thermocouples of cupronickel.

3.2 Cables from buffer

3.2.1 Total pressure

Kulite and Geocon

The sensors are made of titanium and will be delivered with titanium tubes of different lengths (1-8m) welded to the body and with an electrical cable with a length of 100m. The titanium tube (D=6mm, d=4mm) will protect the electrical cable through the bentonite. When entering the backfill there will be a change to polyamide tube (D=8mm, d=5mm).

Polyamide tubes of suitable lengths will be thread over the electrical cable and connected to the titanium tube with a Swagelok ferrule connection. The gauge is now ready for installation on the predestined flange. Ferrule connections are mounted on the flange in advance, see Figure 3-1. The polyamide tubes will be pulled through these a decided length (about 70 m) in order to have a suitable length left in the test volume together with the sensor. Before mounting the head flange on the cone, the ferrule connections will be tightened.

3.2.2 Pore Pressure

Kulite and Geocon

The gauges will be handled in the same way as the total pressure gauges.

3.2.3 Relative Humidity

Instruments will be delivered from two suppliers, Rotronic and Vaisala. A principal difference is that the instruments from Vaisala have a maximum length of the cable from the sensor to the transmitter of 10m. This means that an electronic box must be built in to a vessel and be left in the test volume. Rotronic have built in some of the electronic in the sensor body and the rest can be placed at any distance from the sensor. Hence, the sensors must be handled in different ways.

Rotronic

The sensors will be build into titanium cases. Titanium tubes will protect the electric cables and sensors in the bentonite, Appendix 3. The length of a titanium tube depends on the position of the sensor in the deposition hole. The rest of the cable will be protected by a polyamide tube with an outer diameter of 10 mm and an inner diameter of 6 mm. The polyamide tube will be treated in the same way as the tubes from the pressure transducers.

Vaisala

The gauges will be delivered with 10 m long electrical cables, connecting the sensor to a box containing electronics. 10 m is the maximum length of the cable, witch means that the electronic box must be left in the test volume. The boxes will be build into specially made containers (Appendix 1) in pairs and the cable and sensor bodies will be protected by titanium tubes as shown in Appendix 2. The work will be done in the following way:

1. The electrical cable will be released from the electronic box by soldering.
2. The electric cable will be pulled through a special designed titanium tube with a case for the sensor body see Appendix 2. The length of the titanium tube depends on the position of the sensor in the deposition hole.
3. A polyamide tube will be pulled over the last length of the cable, leaving about 10 cm free. A Swagelok ferrule connection will connect the titanium tube and the polyamide tube.
4. Swagelok ferrule connectors will be mounted on the cap of the container. The free end of the electric cable can now be pulled through one of these and be connected to the electronic box again. Finally the ferrule connection can be fastened.
5. Function tests and calibrations of the sensors will be done after the soldering.
6. Titanium filters will be fastened on the top of the cases.
7. Tubes containing multi wire cables, for voltage supply and output signals, will be pulled through an earlier decided flange. They can be pulled through from the low pressure side in order to minimize the length to be pulled through. One tube will be connected to each vessel containing the electronic boxes. This will be done when the sensors are placed in the bentonite.

3.2.4 Temperature

BICC Thermocouples

The thermocouples are made of cupronickel and will not need any additional protection. Ferrule connections will be mounted on the flange in advance, see Figure 3-1. The thermocouples will be pulled through these a decided length (about 10-20 m depending on the final position in the deposition hole) from the low pressure side in order to have a suitable length in the test volume. Before mounting the head flange on the cone, the ferrule connections will be tightened.

3.3 Cables from backfill

3.3.1 Total pressure

Kulite and Geocon

The sensors are made of titanium and are delivered with a titanium tube (D=6mm, d=4mm) with a length of 0.1m welded to the body and with an electrical cable with a length of 100 m. The rest of the cable will be protected by a polyamide tube with an outer diameter of 8 mm and an inner diameter of 5 mm. The polyamide tube will be treated in the same way as the tubes from the pressure transducers in the buffer.

3.3.2 Pore Pressure

Kulite and Geocon

The gauges will be handled in the same way as the total pressure gauges.

3.3.3 Relative Humidity

Wescor

The Wescor sensors must be handled in a special way. Laboratory tests have shown that when the backfill material is saturated and a water pressure is built up, leakage will occur through the sensors and through the electric cables. This is not acceptable and in order to avoid this a rebuilding of the sensor will be done. A mechanical protection of the sensor is also needed.

The sensor body will be delivered with a special electric cable connected. This cable will be peeled a length of about 3 cm, beginning about 2 cm from the sensor. The uncovered copper wire will then be locked in distances in order to not let them touch each other. The length will then be cast with epoxy. The cable will then be pulled through a case with a short tube see Appendix 4. When positioned in the case an additional casting of epoxy will be done in order to seal between the case and the earlier epoxy casting. A titanium filter will be mounted on the top of the case. The rest of the cable will be protected by a polyamide tube with an outer diameter of 8 mm and an inner diameter of 5 mm. The polyamide tube will be treated in the same way as the tubes from the pressure transducers in the buffer.

3.3.4 Temperature

BICC Thermocouples

The gauges will be handled in the same way as the thermocouples in the buffer.

3.3.5 Resistivity

The resistivity of the backfill material will be measured in one profile in the Section 1. GRS is responsible for the measuring. 36 single electrodes are connected to a multiwire cable. The cable which is of the same type as the power cables to the heaters, do not need any additional protecting. A Gisma plug mounted on the head flange will connect the cable on the high pressure side and another cable mounted on the low pressure side. The cable on the low pressure side will be mounted in advance together with a Gisma socket on the flange. The cable in the test volume, equipped with a Gisma plug can then be connected to the socket when the installation is ready. The installation is described in AP TD F63-00-077.

3.4 Cables from rock

3.4.1 Hydrology

All these tubes are off hydraulic type i.e. they are all leading out water from the test volume, through the rock, out to the G-tunnel. The tubes are made of polyamide all the way from the measuring point out to the G-tunnel. The polyamide tube will be treated in the same way as the tubes from the pressure transducers in the buffer.

3.4.2 Sampling and hydrochemical

All these tubes are off hydraulic type i.e. they will all be leading out water from the test volume, through the rock, out to the G-tunnel. The tubes are made of PEEK all the way from the measuring point out to the G-tunnel.

The tubes will be handled in the same way as those from the hydrology.

3.4.3 Temperature

BICC Thermocouples

The gauges will be handled in the same way as the Thermocouples in the buffer.

3.4.4 Drainage

All these tubes are off hydraulic type i.e. they are all leading out water from the test volume, through the rock, out to the G-tunnel. The tubes are made of polyamide all the way from the measuring point out to the G-tunnel.

The tubes will be handled in the same way as those from the hydrology.

4. Design of cable parcels

4.1 Quantity and distribution of cables and tubes

The total number of cables and tubes that will be led through the rock to the adjacent tunnel is as follows (Tables 4-1):

Canisters (4 pcs.)

- **Kockums:** 12 power cables with a diameter of 32 mm. (Polyether-Polyurethane).
- **CT:** 16 fiber optic temperature cables with a diameter of 2 mm. (Inconel).
- **Aitemin:** 6 tubes leading fiber optic cable from gauges measuring displacement of the canisters (canister 3). with a diameter of 8 mm (Titanium)

Bentonite (2 instrumented deposition holes)

- **CT:** 54 tubes with a diameter of 8 mm from total pressure gauges. (Titanium/Polyamide)
- **CT:** 28 tubes with a diameter of 8 mm from pore pressure gauges. (Titanium/Polyamide)
- **CT:** 54 cables with a diameter of 10 mm from relative humidity sensors. (Titanium/Polyamide)
- **CT:** 64 thermocouples with a diameter of 4.0 mm for temperature measurements. (Cupronickel)

Backfill (2 sections type E with 30 gauges each, 3 sections type F with 12 gauges each and 12 gauges in the rest of the backfill, see Instrument report /2-3/)

- **CT:** 20 tubes with a diameter of 8 mm from total pressure gauges. (Polyamid)
- **CT:** 23 tubes with a diameter of 8 mm from pore pressure gauges. (Polyamid)
- **CT:** 45 tubes with a diameter of 8 mm from relative humidity gauges. (Polyamid)
- **CT:** 20 thermocouples with a diameter of 4.0 mm for temperature measurements. (Cupronickel)

Rock

- **VBB VIAK:** 89 tubes with a diameter of 4 and 6 mm respectively, from pore pressure measurements. (Polyamid/Steel/PEEK)
- **KTH:** 8 tubes with a diameter of 1/8" from sampling of water and gas. (PEEK).
- **GRS:** 1 cable with a diameter of 25.7 mm from resistivity measurements (Polyether-polyurethane).
- **NCC:** 37 thermocouples with a diameter of 4.0 mm. (Cupronickel)

4.2 Principal design of flanges

In order to facilitate installation and handling of cables and tubes, a rough division will be made depending on where the measuring points are located i.e. a flange contains cables and tubes from either buffer, backfill, rock or canister with some exceptions.

16 lead throughs are needed for Section 1, i.e. the four innermost deposition holes. The distribution of cables on the head flanges of each lead through, see Figure 1-1, have been decided depending on the sizes of the cables. The thicker cables are positioned in the center of the flanges in order to minimize the bending radius and by that facilitate the installation. The thinner thermocouples are mainly placed in the periphery of the flanges. The distribution of cables on the 16 lead throughs is shown in Table 4-1.

The power cables from the canister will be led separately depending on the risk of disturbing other instruments. One exception is the optic fiber cables measuring temperature and displacement of the canister. From each deposition hole, will the power cables and the fiber optic cables be led together in the same lead through.

The designs of each flange are shown in Appendices 5-20.

Table 4-1. Table showing the distribution of cables and tubes in the lead throughs at the four inner deposition holes.

Prototype Repository			Deposition hole DA3587G01 Number of tubes/cables LT 11 LT 12 LT 13 LT 14				Deposition hole DA3581G01 Number of tubes/cables LT 21 LT 22 LT 23 LT 24				Deposition hole DA3575G01 Number of tubes/cables LT 31 LT 32 LT 33 LT 34				Deposition hole DA3569G01 Number of tubes/cables LT 41 LT 42 LT 43 LT 44				Sum	
Measuring place	Tube d mm	Lead through type	Material																	
Canister																				
Power cables	32	Flange receptacle	PE-PUR	3																
Optic fiber	2	Swagelok	Inconel	4																
Displacement	8	Swagelok	Titanium																	
Bentonite																				
Total pressure	8	Swagelok	Titanium/Polyamid	27																
Pore pressure	8	Swagelok	Titanium/Polyamid	14																
Relative humidity R	8	Swagelok	Titanium/Polyamid	17																
Relative humidity V	8	Flange receptacle	Titanium/Polyamid		20															
Temperature	4	Swagelok	Cupronickel	32																
Backfill																				
Total pressure	8	Swagelok	Polyamid		9															
Pore pressure	8	Swagelok	Polyamid		11															
Relative humidity W	8	Swagelok	Polyamid		20															
Temperature	4	Swagelok	Cupronickel		9															
Resistivity	25.7	Flange receptacle	Multicable																	
Rock																				
Hydro	4/6	Swagelok	Tecalan/Peek	29																
Sampling	1/8"	Swagelok	PEEK	8																
Resistivity	25.7	Flange receptacle	Multicable																	
Temperature	4	Swagelok	Cupronickel	15																
Rock mechanical	19	Swagelok	Multicable																	
Acoustic emission	1/4"	Swagelok	PE-PUR																	
Water drainage	8	Swagelok	Polyamid	6																
Sum				58	46	44	7	29	49	28	7	49	41	13	23	31	25	34	7	491

5 Assembling of cable parcels

All cable/tube parcels, except for the one leading out cables from the canister, will be prepared in advance. The mounting will be done in the A-tunnel, outside the Prototype tunnel. The parcels leading out cables from the canister can not be prepared in advance since the optic fiber cables are already fixed to the canister.

A function test will be done on all instruments before installation.

5.1 Parcels including cables from canister

Each flange containing cables from the canister will be mounted on a wagon with wheels specially designed for the purpose. The wagon will be placed close to the deposition hole. All tube fittings, for the fibre optic cables, will then be mounted on the flange. These cables will be pulled through the tube fittings, until a decided length remains. Flange receptacles will be mounted in advance on the power cables, which means that the cables will be pulled through holes in the head flange until the pre mounted flanges reach the head flange. These will then be fixed to the head flange by bolts. Gaskets must be mounted before pulling the cables through the head flange,.

The cables will be ID-marked in both ends and gathered by strings every meter. Depending on the cable lengths and the limited space in the tunnel, the tube parcel must be led out from the TBM-tunnel and then back again to the chosen lead through hole before the installation.

5.2 Parcels including cables from bentonite, backfill and rock

These parcels will be installed in advance i.e. before deposition of the bentonite blocks. The procedure will be almost as described for the cables from the canisters except that the wagon with the flange will be placed outside the Prototype tunnel where the assembling will be done. The work will be done as follows:

1. Each flange will be mounted on the specially designed wagon. The flanges can be fixed during mounting of tube fittings and installation of tubes. The frame is equipped with wheels and will later be rolled forward during installation of the cable parcel through the bore-holes
2. All tube fittings will be mounted on the flange according to directions.

3. The tubes will then be pulled through the tube fittings. They will be handled somewhat different depending on type:

Kulite, Geocon, Wescor and Rotronic:

The tubes, with the sensors in one end and the electric cable covered with polyamide tube in the other, will be pushed through the flange from the high pressure side. This means that about 90 m have to be pushed through. The length of the tube on the high pressure side will be adjusted according to directions.

Vaisala

The tubes containing an electric cable (which later will be connected to the specially designed vessel, containing the electronic boxes from two sensors) will be pushed through the tube fittings from the low pressure side, which means that about 15 m have to be pushed through.

Thermocouples

The thermocouples will be pulled through the tube fittings from the low pressure side which means that about 15 m will have to be pushed through. The length will be adjusted according to directions.

Hydraulic tubes, sampling and hydro-chemical tubes

The hydraulic tubes will be handled like the thermocouples i.e. they will be pushed through from the low pressure side with a decided length.

4. Each tube installed will be marked with a special ID number in both ends.
5. When all tubes are mounted and the lengths on the high pressure side are controlled, the tube fittings on the flange will be fastened.
6. The tubes on the low pressure side i.e. the tubes that will be pulled through the lead throughs, will then be collected in a parcel by strings placed every meter. This will facilitate the installation. The tubes on the high pressure side will be rolled together and locked with strings. These cable rolls will then be hanged on the rock wall until the sensors are installed.

6 Installation of cable parcels

1. All tube fittings on the flange will be checked and fastened.
2. A steel wire will be pushed through the lead through hole from the G-tunnel.
3. A gasket will be mounted on the steel collar in the Prototype tunnel.
4. The cable parcel will be fastened to the steel wire.
5. The cable parcel will now be pulled through the bore hole. One man will pull the wire from the G-tunnel and one will guide the tubes when they are entering the bore-hole. A number of persons will be lifting and guiding the cables in the Prototype tunnel.
6. When only a few meters remain, the head flange will be released from the wagon and lifted by hand the final meters to the steel collar. The flange will then be fastened to the collar by bolts.

References

- /2-1/ Dahlström L-O.** Test Plan for The Prototype Repository
- /2-2/ Collin M and Börgesson L.** Prototype Repository. Instrumentation of buffer and backfill for measuring THM Processes.
- /2-3/ Sandén T and Börgesson L.** Prototype repository, Report on instrument positions in buffer/backfill and preparation of bentonite blocks for instruments and cables in Section 1.

APPENDIX 1

RevNo	Revision note	Date	Signature	Checked

5	1	Lock 2, SS2343	Ritning 001115-3
4	1	Cylinder, SS2343	Ritning 001115-2
3	2	O-ring 209.3 x 5.7, Nitril	
2	1	Lock 1, SS2343	Ritning 001115-1
1	16	MC6S, SR, M10 x 30	
Itemref	Quantity	Title/Name, designation, material, dimension etc	Article No. / Reference
Designed by TS	Checked by	Approved by-date	File name
			Date
			Scale 1:4
Clay Technology AB Ideon 223 70, Lund Tel: 046-286 2570, Fax: 046-134230		Behållare Vaisalaelektronik	
		Edetion	Sheet

APPENDIX 2

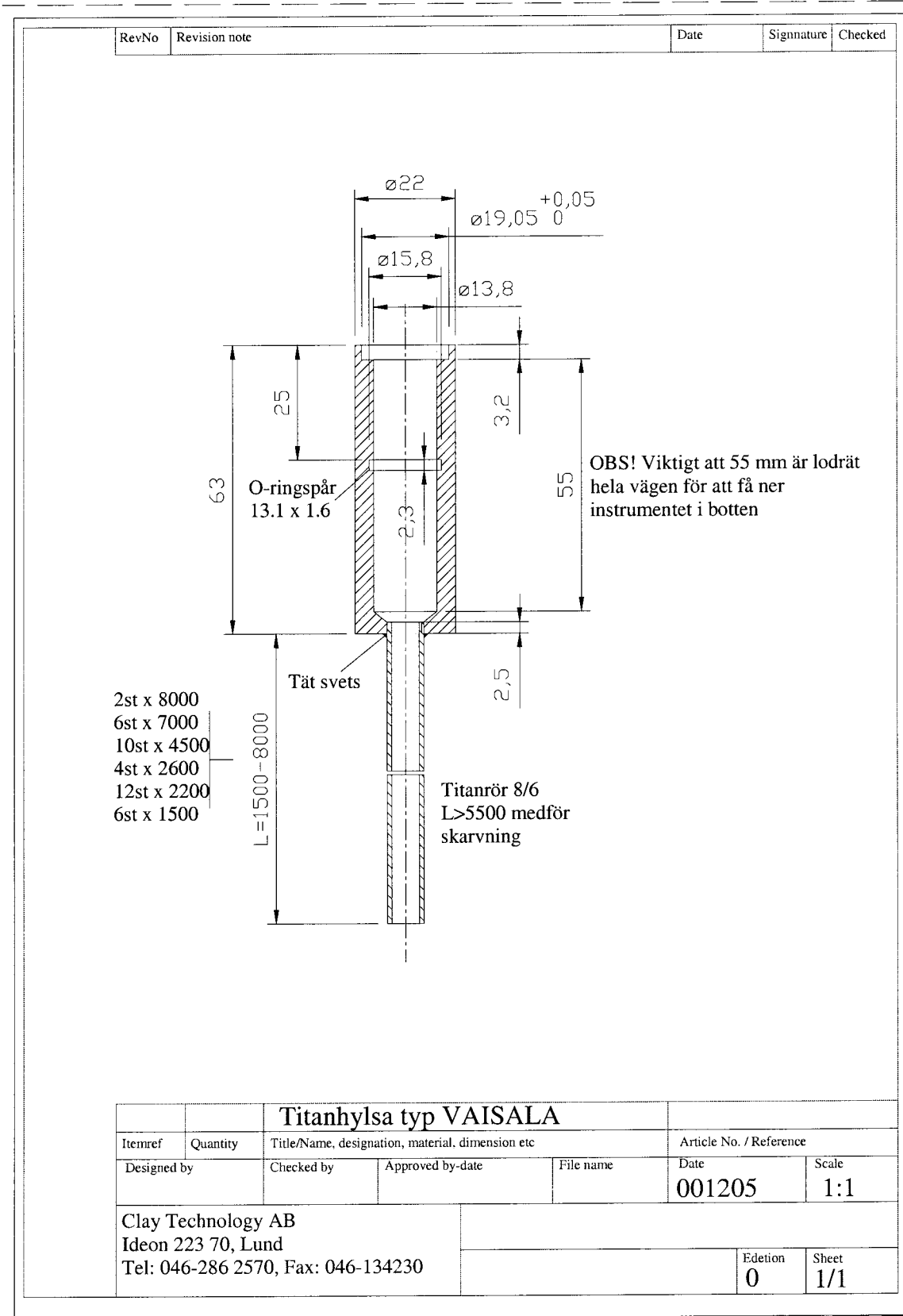

APPENDIX 3

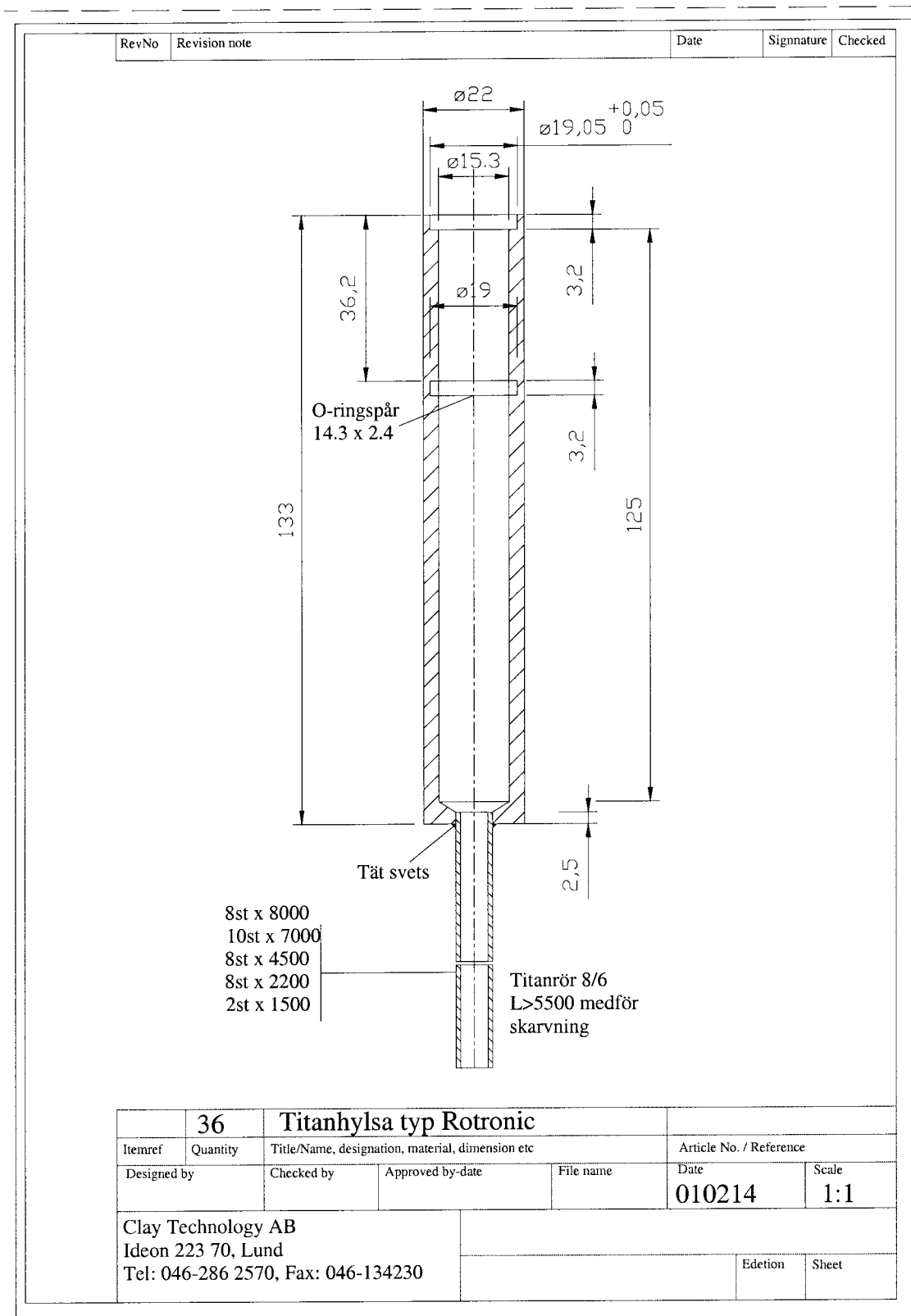

APPENDIX 4

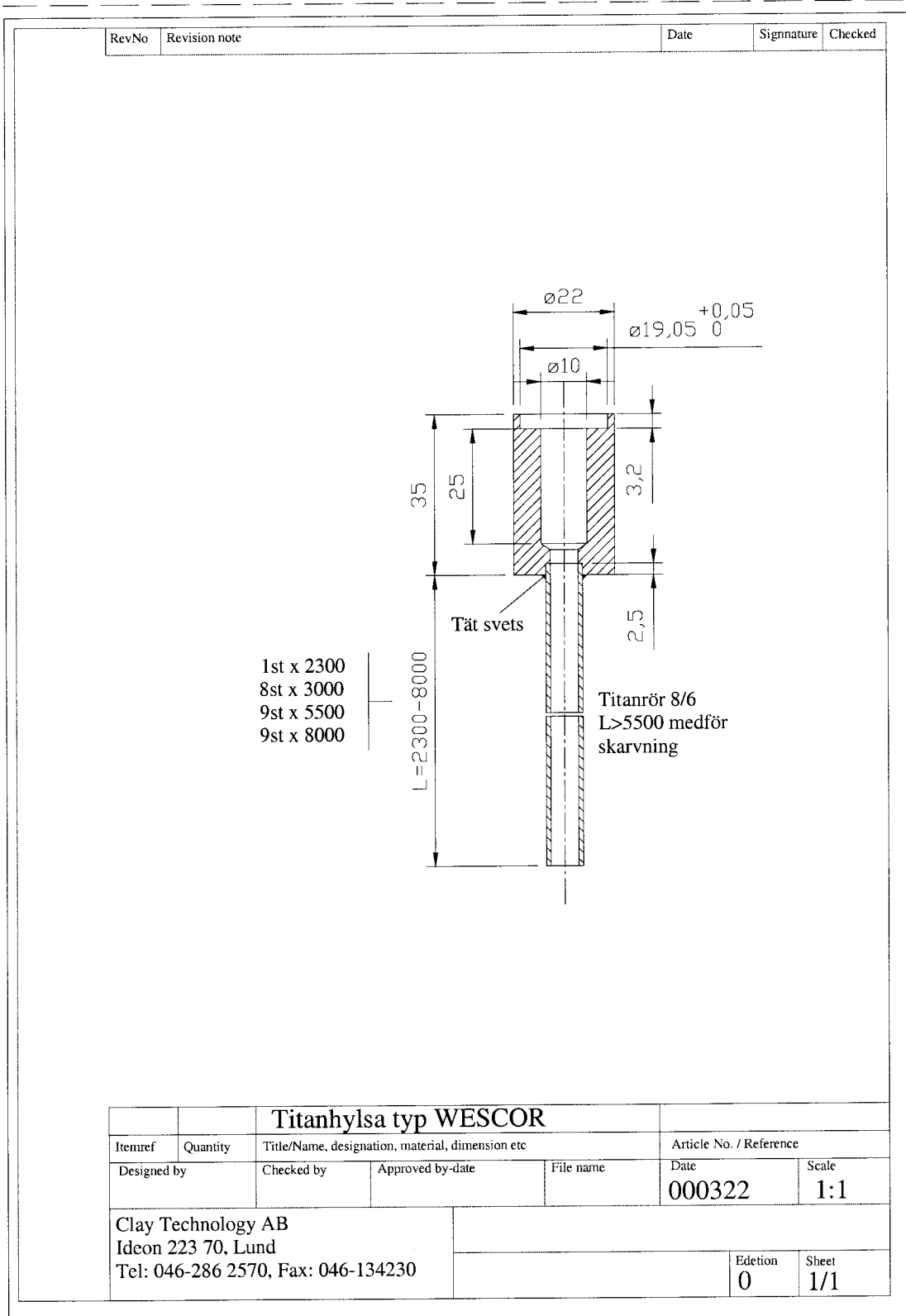

APPENDIX 5

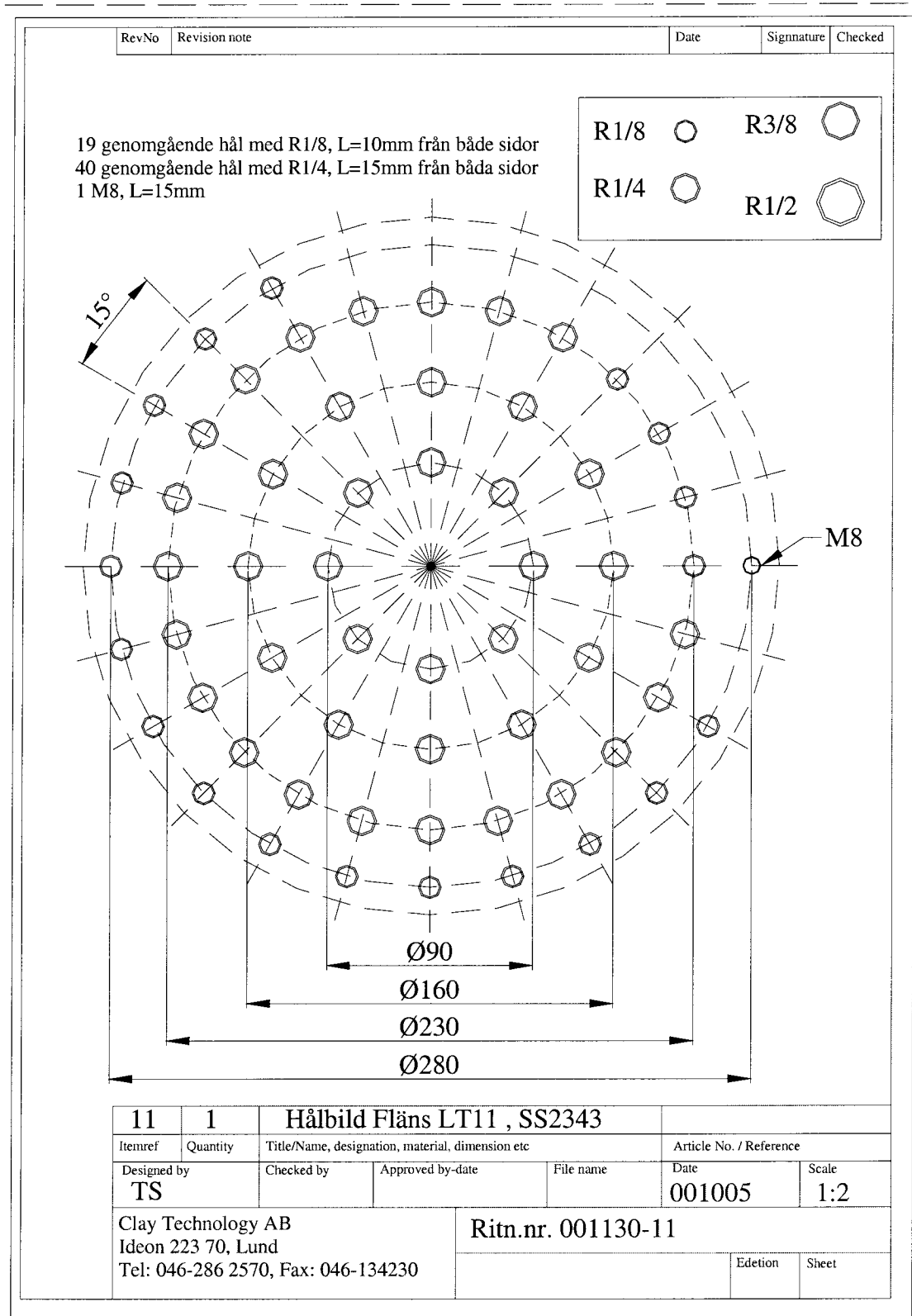

11	1	Hålbild Fläns LT11 , SS2343				
Itemref	Quantity	Title/Name, designation, material, dimension etc			Article No. / Reference	
Designed by	Checked by	Approved by-date	File name	Date	Scale	
TS				001005	1:2	
Clay Technology AB Ideon 223 70, Lund Tel: 046-286 2570, Fax: 046-134230				Ritn.nr. 001130-11		
				Edition	Sheet	

APPENDIX 6

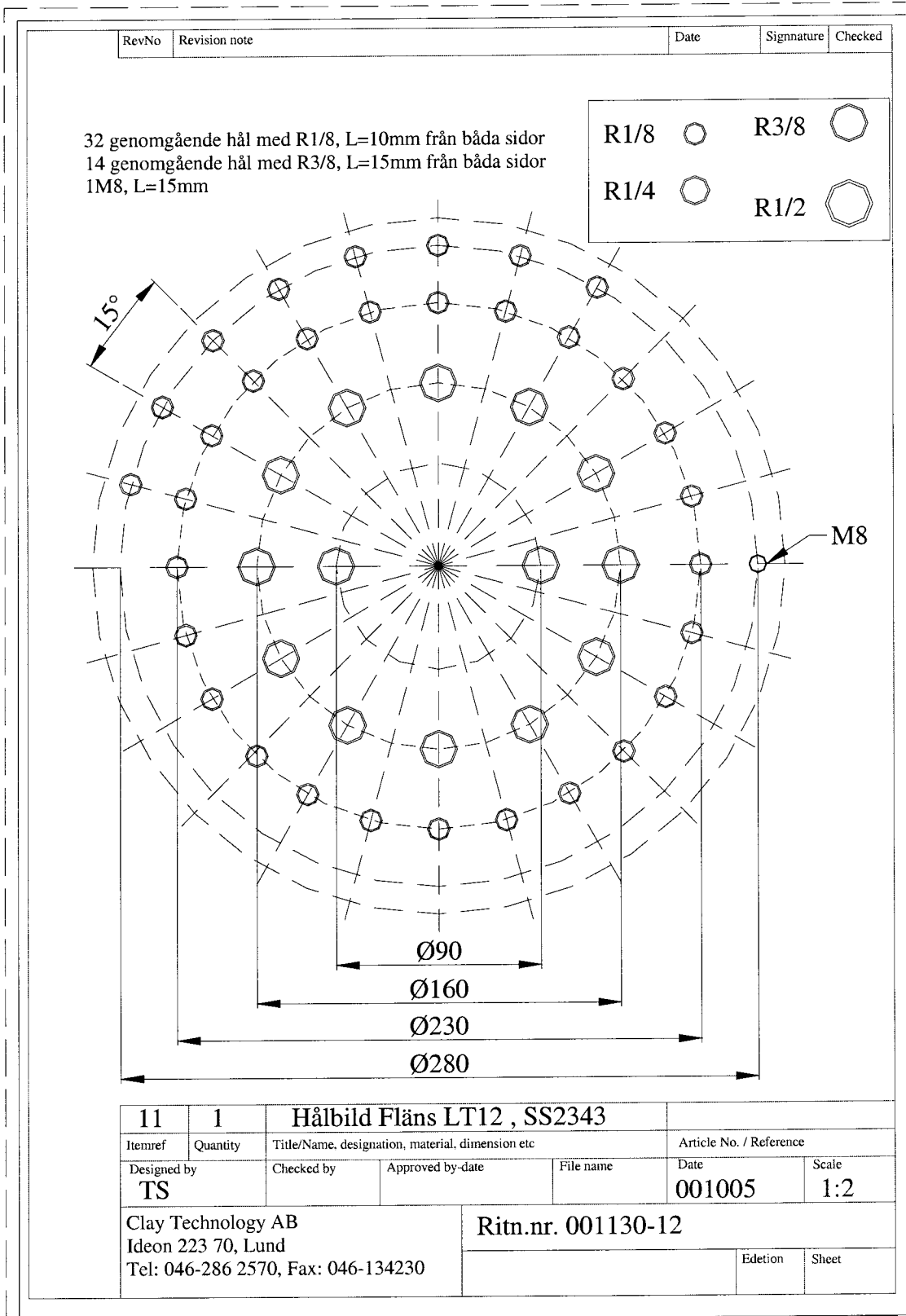

APPENDIX 7

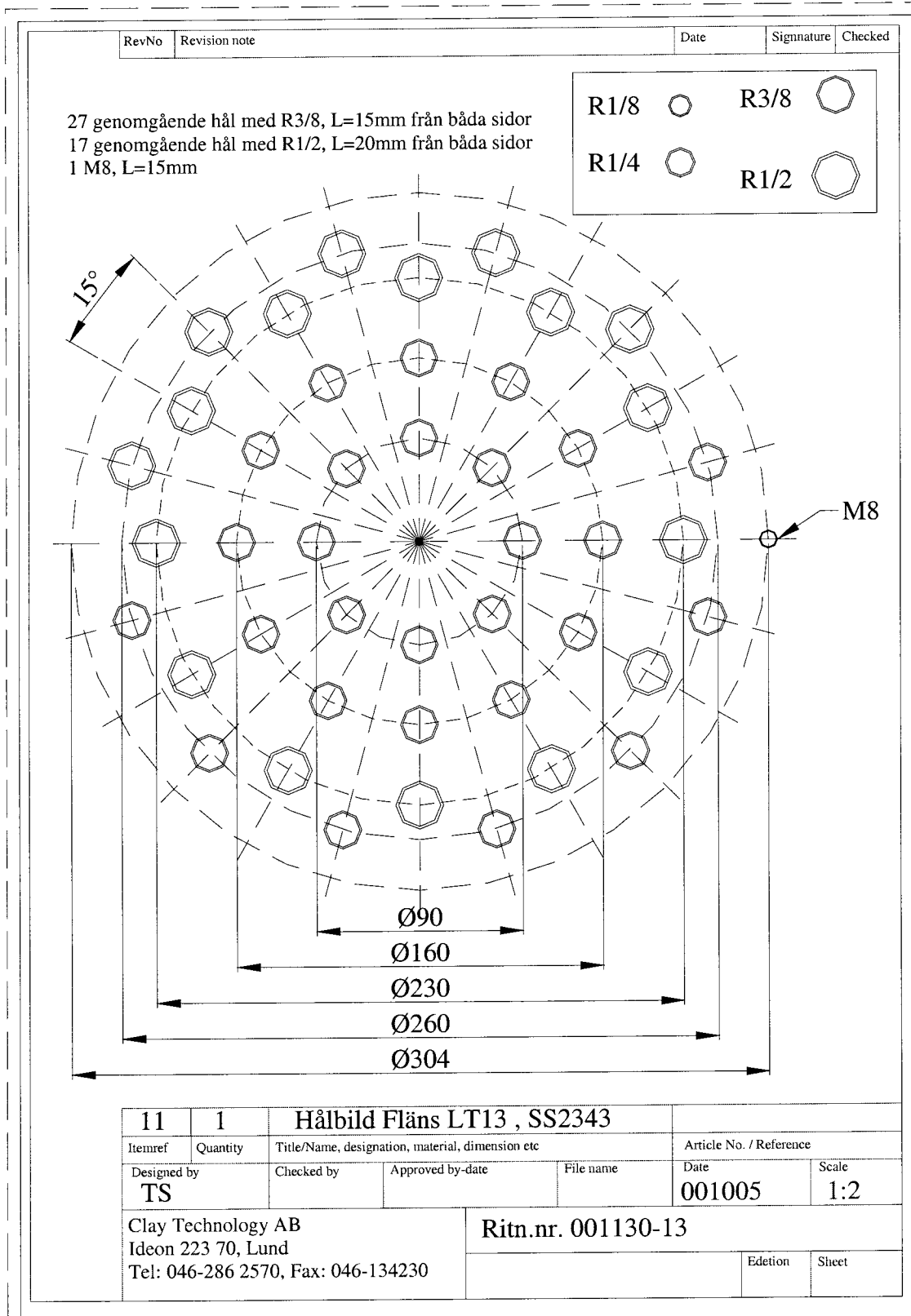

APPENDIX 8

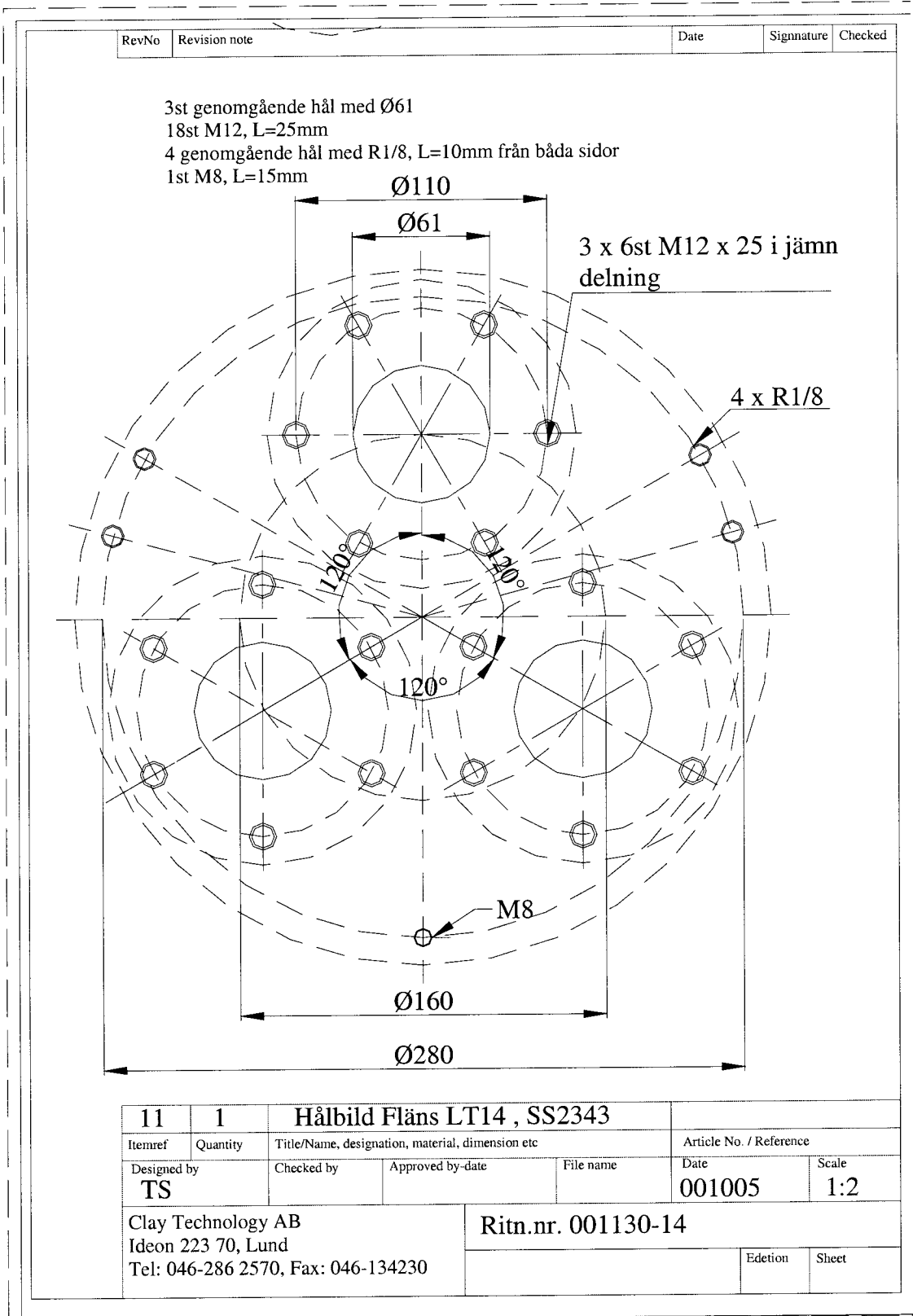

APPENDIX 9

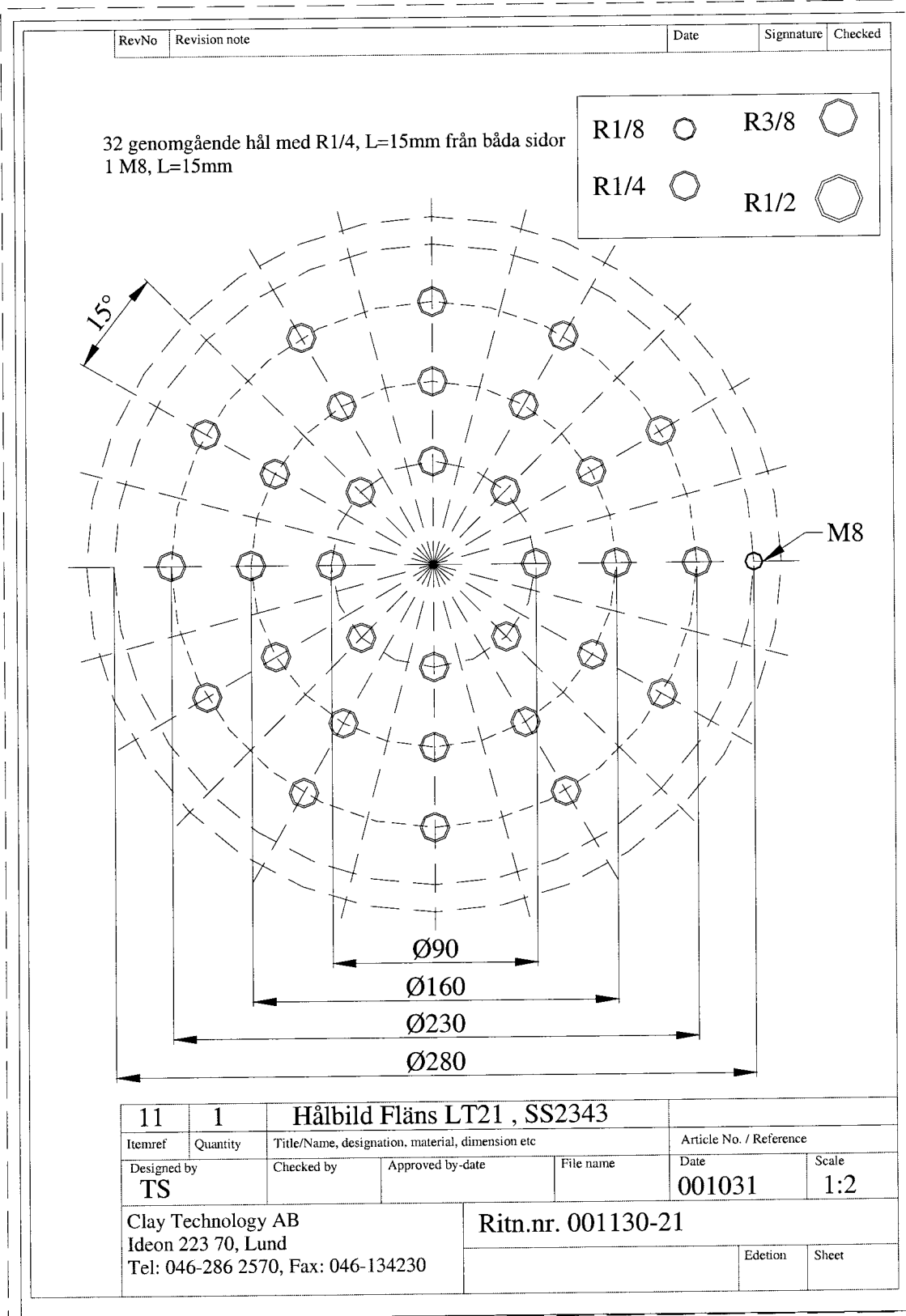

APPENDIX 10

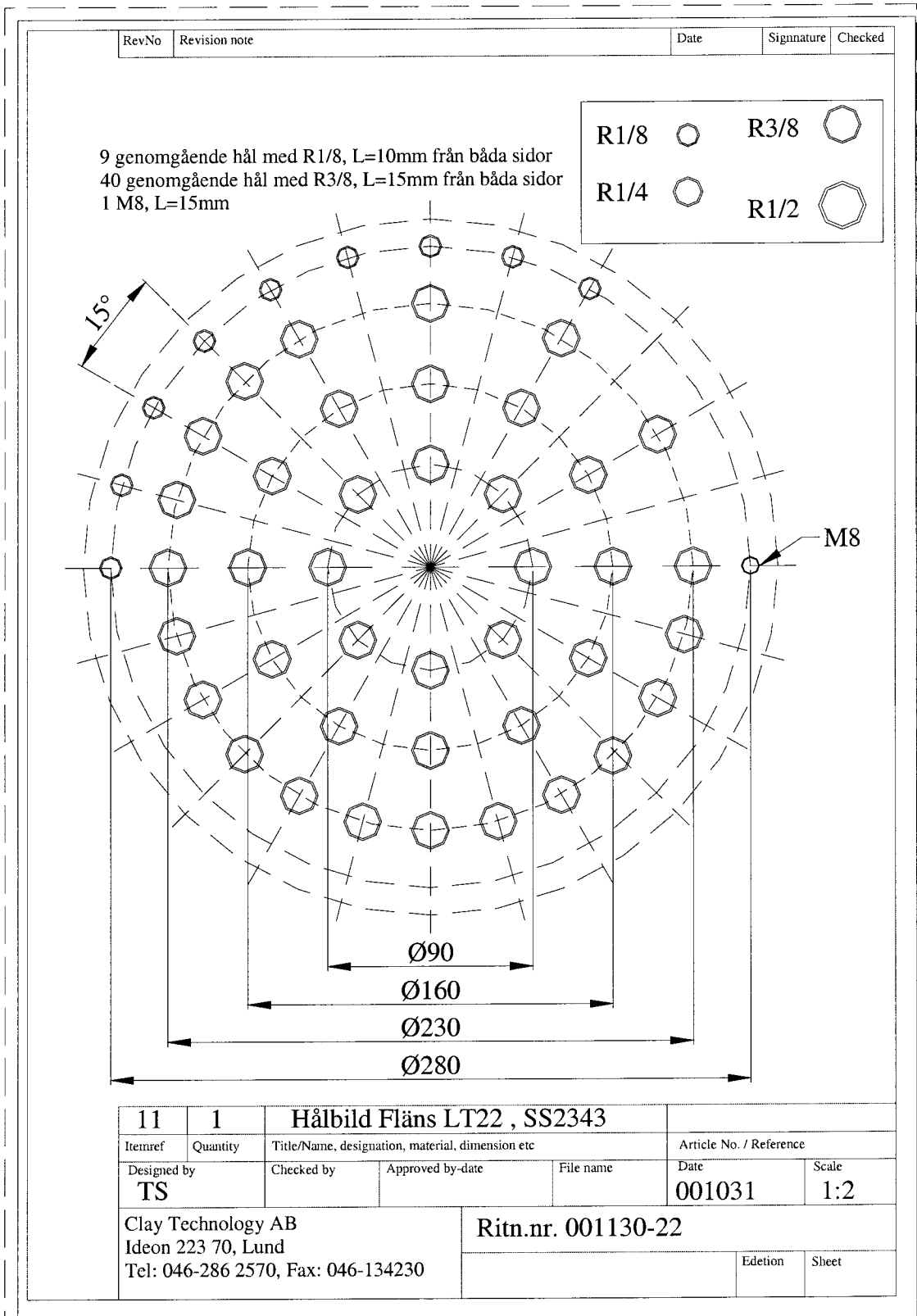

11	1	Hålbild Fläns LT22 , SS2343			Article No. / Reference	
Itemref	Quantity	Title/Name, designation, material, dimension etc			Date	Scale
Designed by	Checked by	Approved by-date	File name	001031	1:2	
Clay Technology AB Ideon 223 70, Lund Tel: 046-286 2570, Fax: 046-134230				Ritn.nr. 001130-22		
				Edition	Sheet	

APPENDIX 11

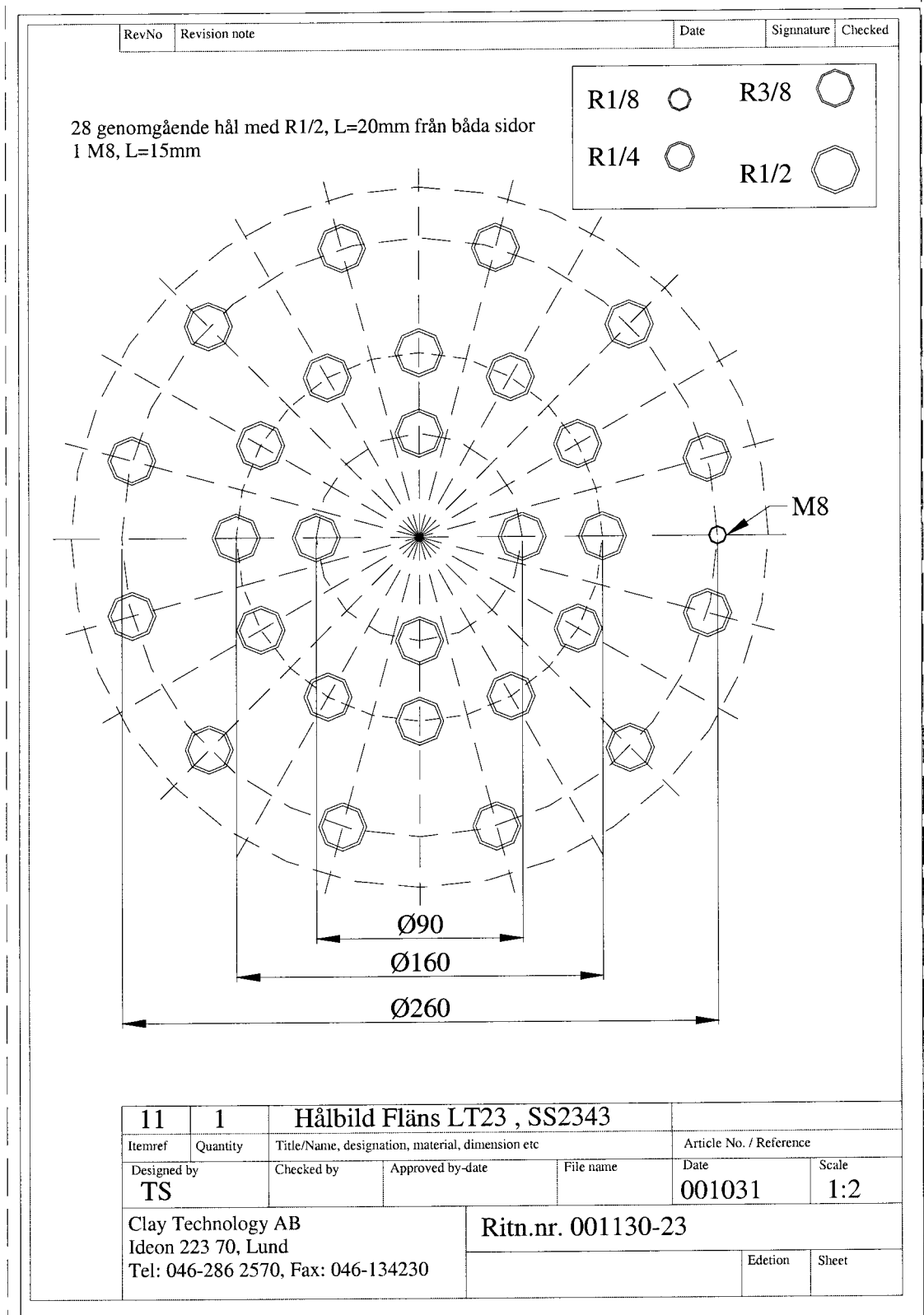

APPENDIX 12

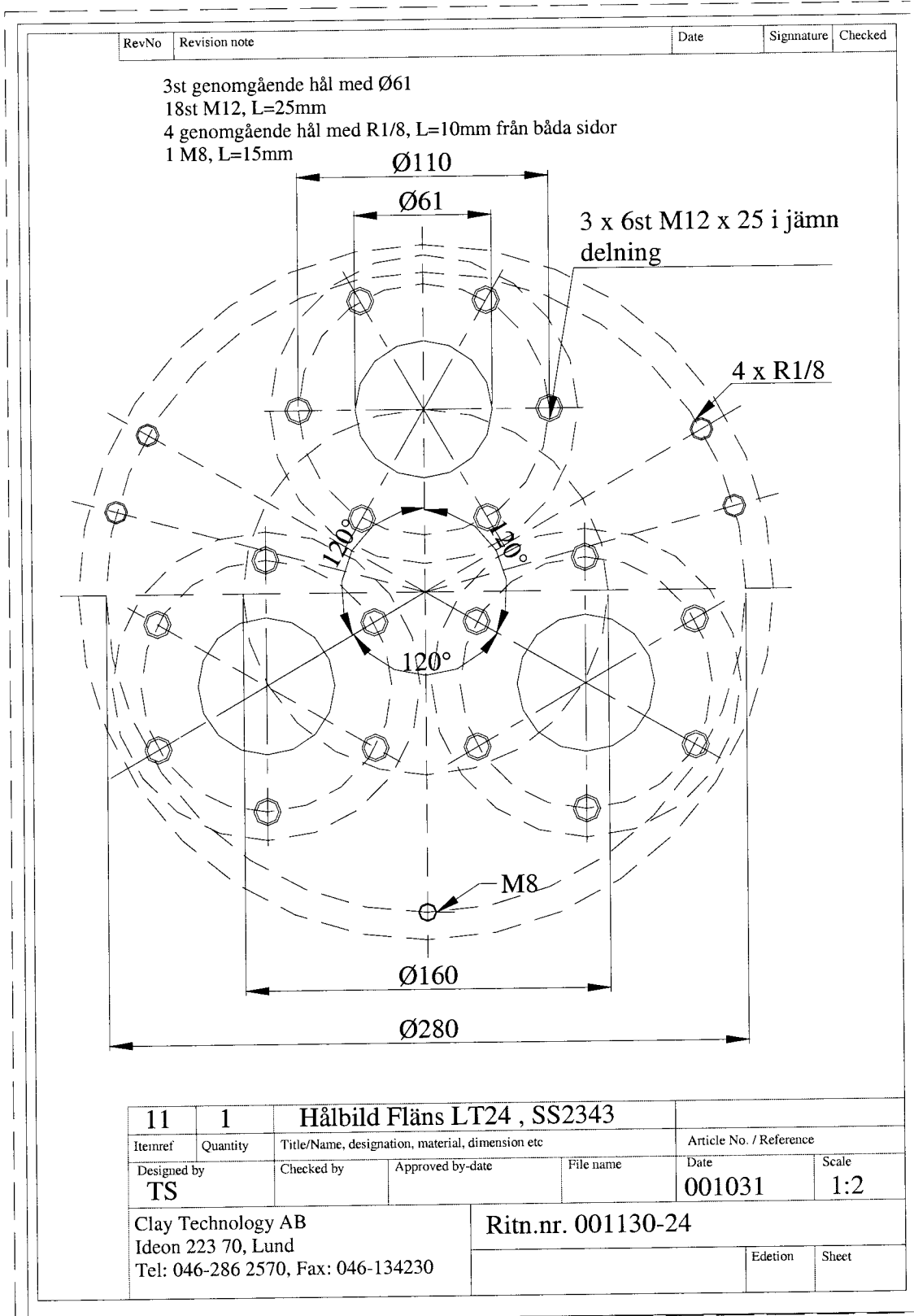

APPENDIX 13

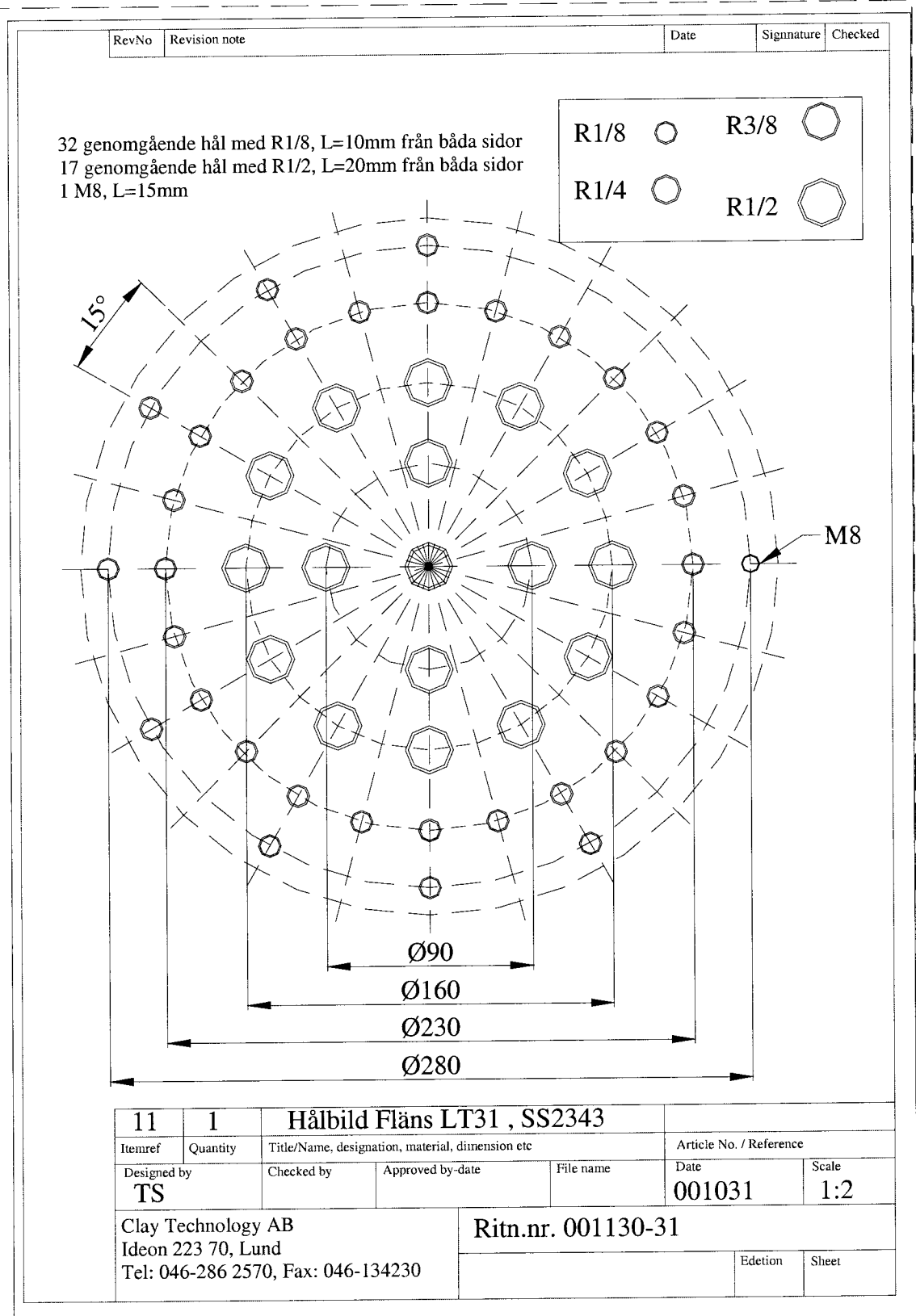

APPENDIX 14

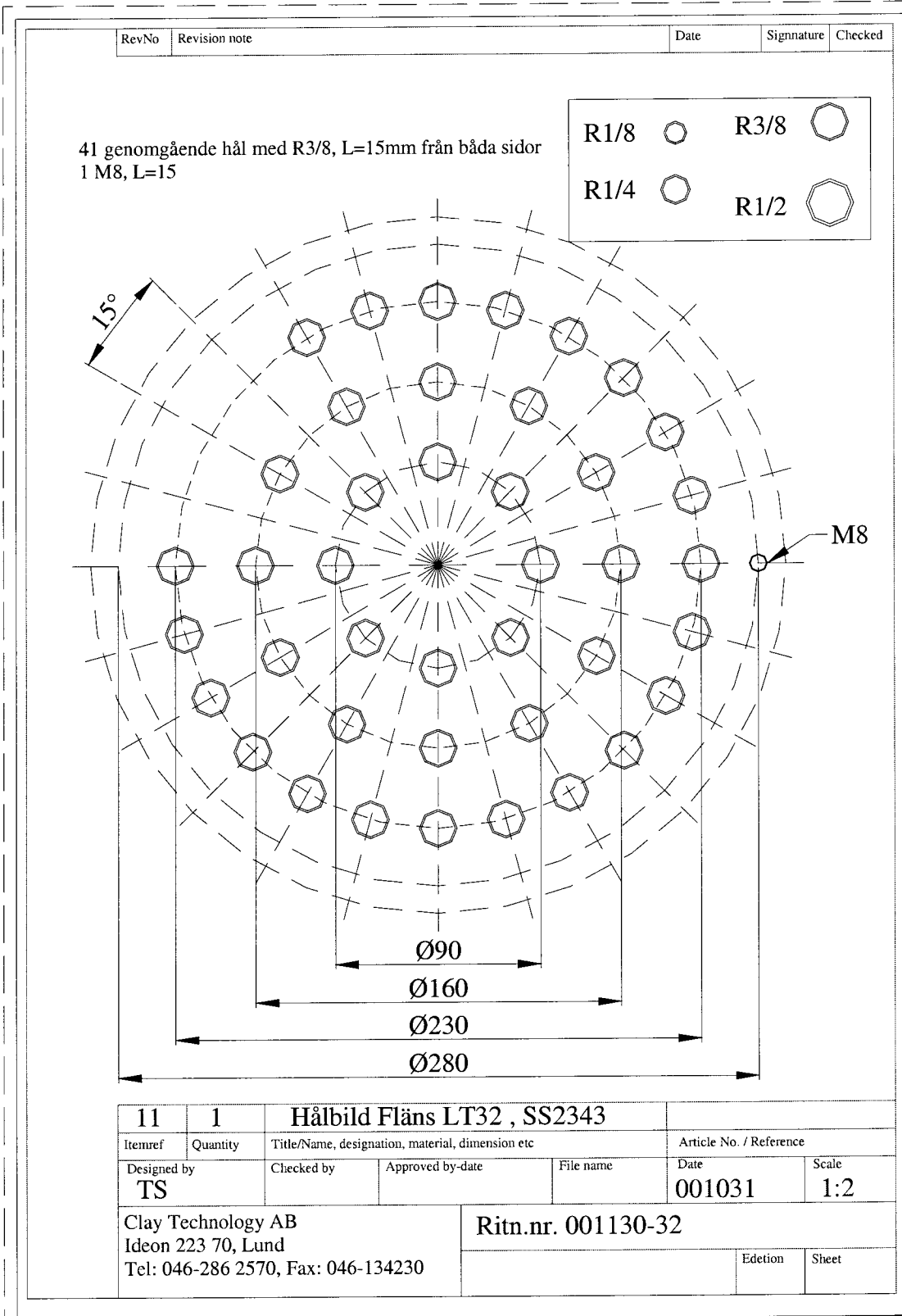

APPENDIX 15

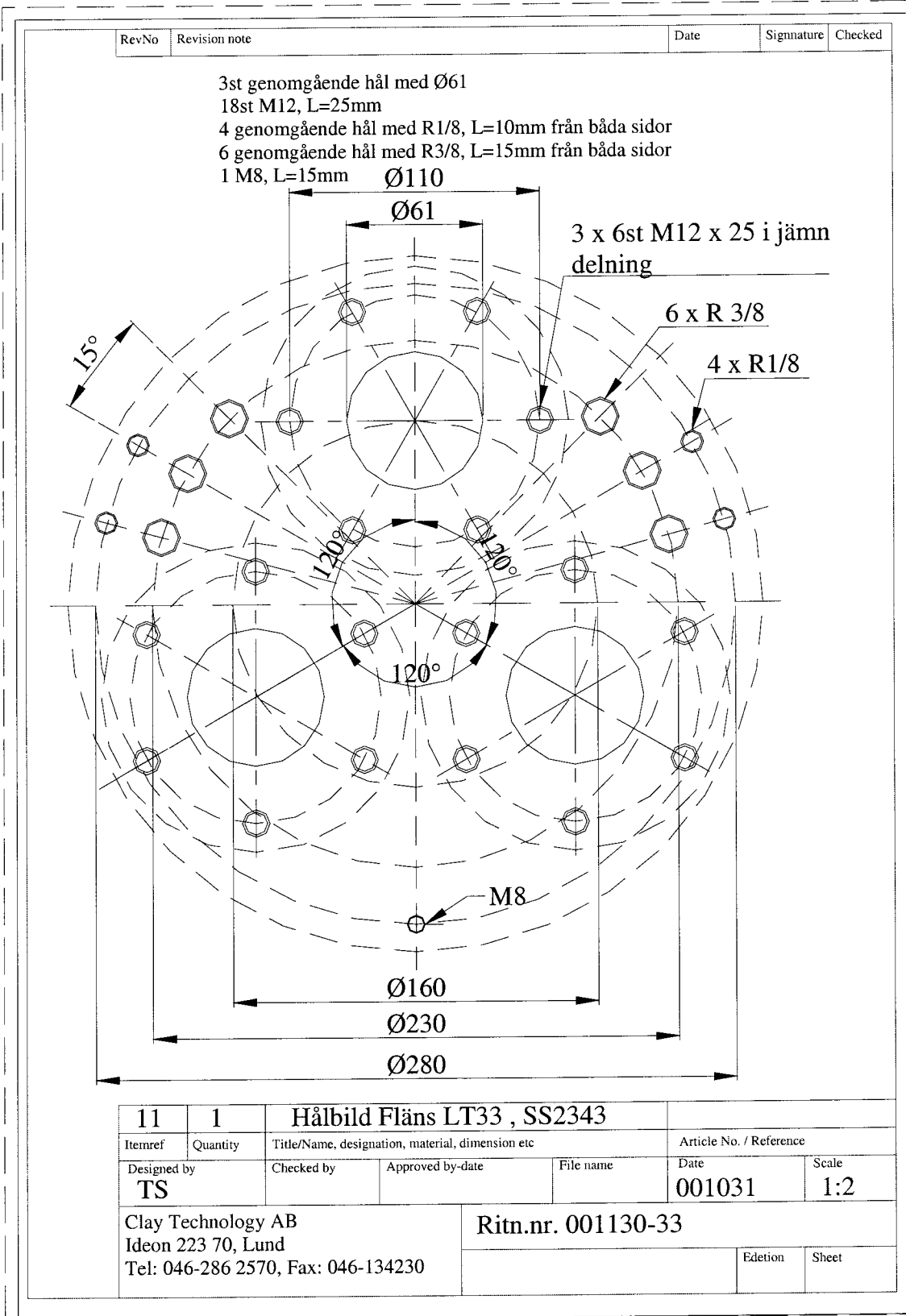

APPENDIX 16

RevNo	Revision note	Date	Signature	Checked
-------	---------------	------	-----------	---------

1st genomgående hål med $\text{Ø}47$
 6st M6, L=20mm
 23 st genomgående hål med R1/8, L=10mm från båda sidor
 1 M8, L=15mm

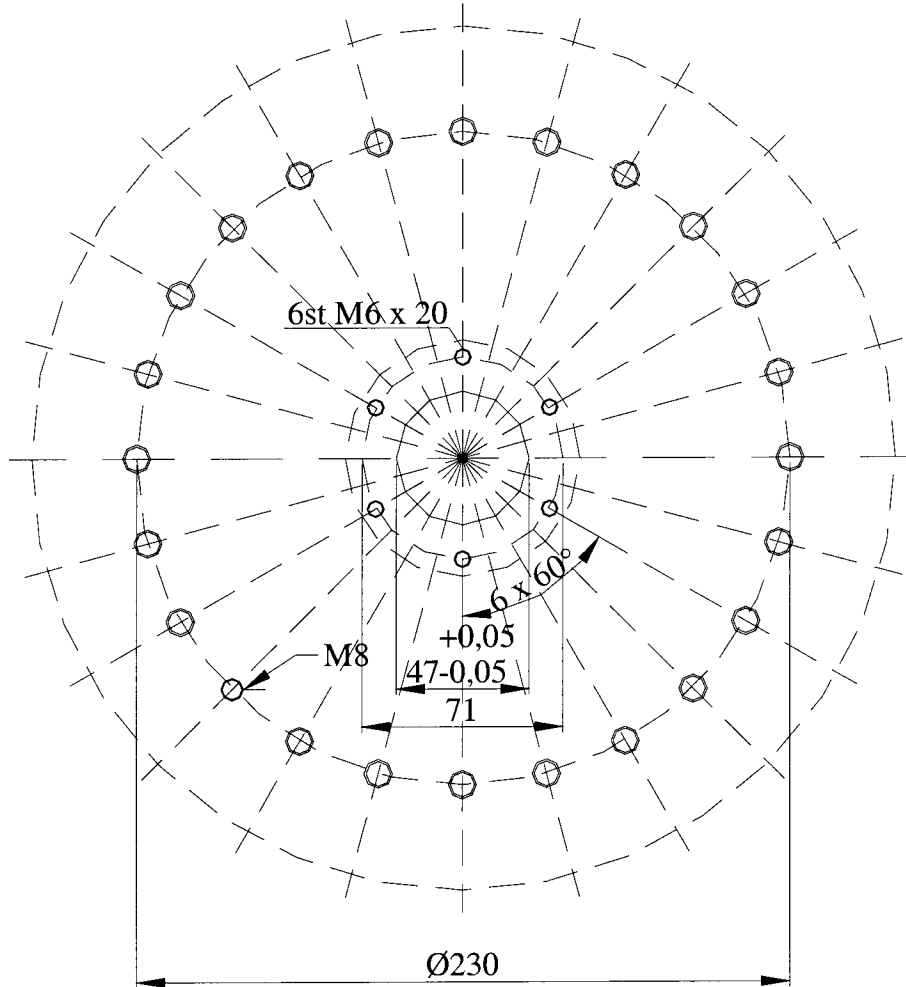

11	1	Hålbild Fläns LT34 , SS2343			Article No. / Reference	
Itemref	Quantity	Title/Name, designation, material, dimension etc			Article No. / Reference	
Designed by TS	Checked by	Approved by-date	File name	Date 001031	Scale 1:2	
Clay Technology AB Ideon 223 70, Lund Tel: 046-286 2570, Fax: 046-134230			Ritn.nr. 001130-34			
				Edetion	Sheet	



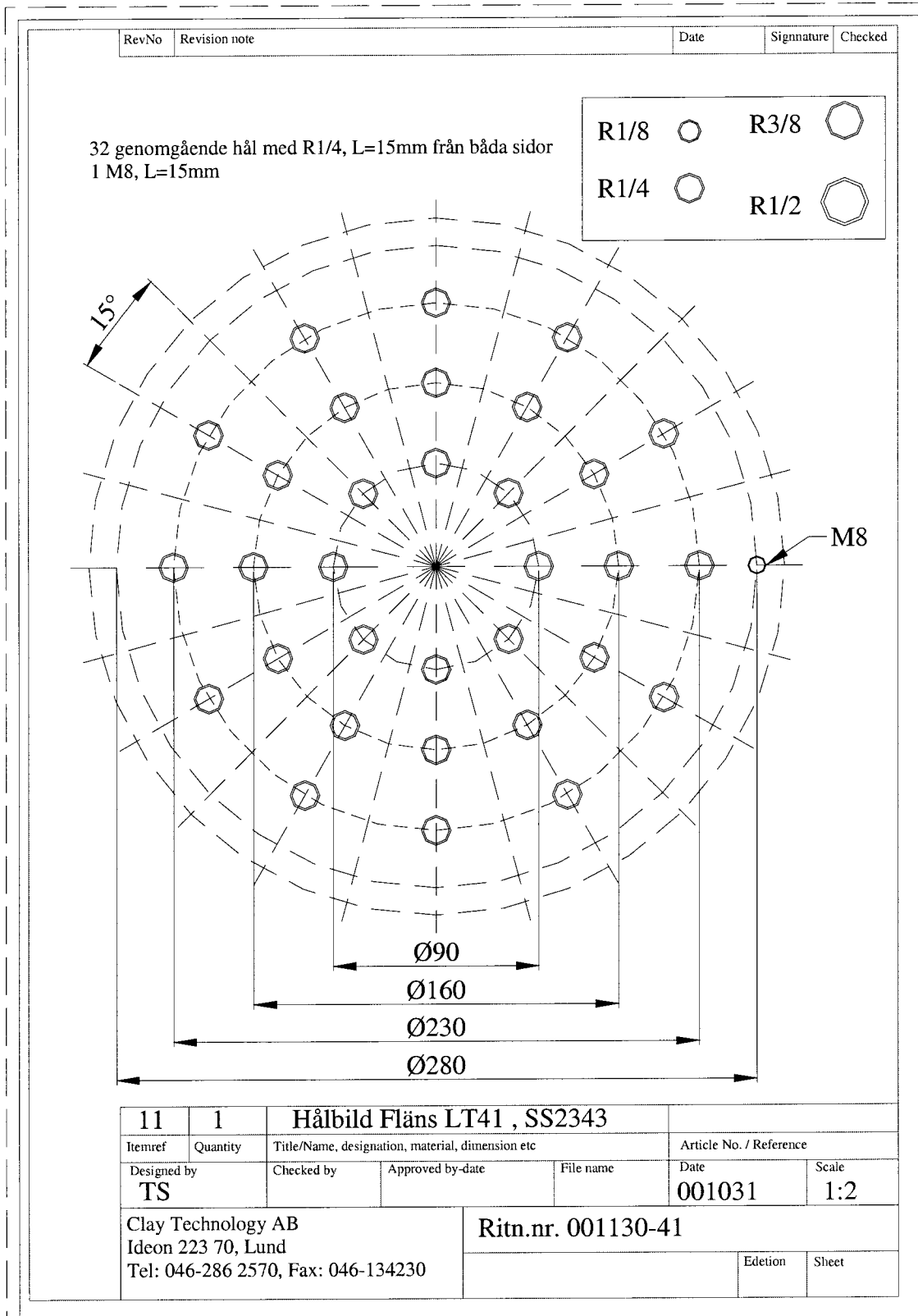

APPENDIX 17



APPENDIX 18

RevNo	Revision note	Date	Signature	Checked
-------	---------------	------	-----------	---------

25 genomgående hål med R3/8, L=15mm från båda sidor
1 M8, L=15mm

R1/8		R3/8	
R1/4		R1/2	

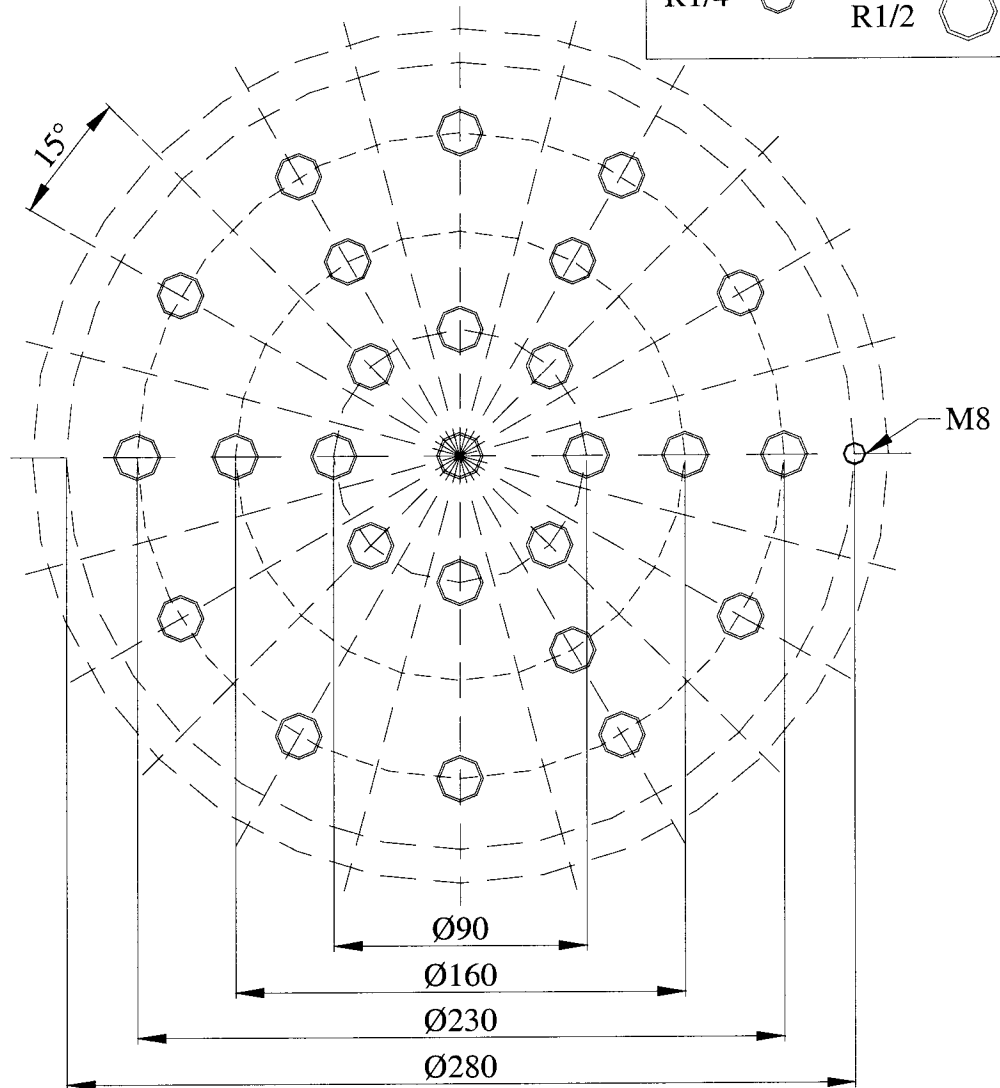

11	1	Hålbild Fläns LT42 , SS2343			Article No. / Reference	
Itemref	Quantity	Title/Name, designation, material, dimension etc			Date	Scale
Designed by TS	Checked by	Approved by-date	File name	001031	1:2	
Clay Technology AB Ideon 223 70, Lund Tel: 046-286 2570, Fax: 046-134230			Ritn.nr. 001130-42			
				Edition	Sheet	

APPENDIX 19

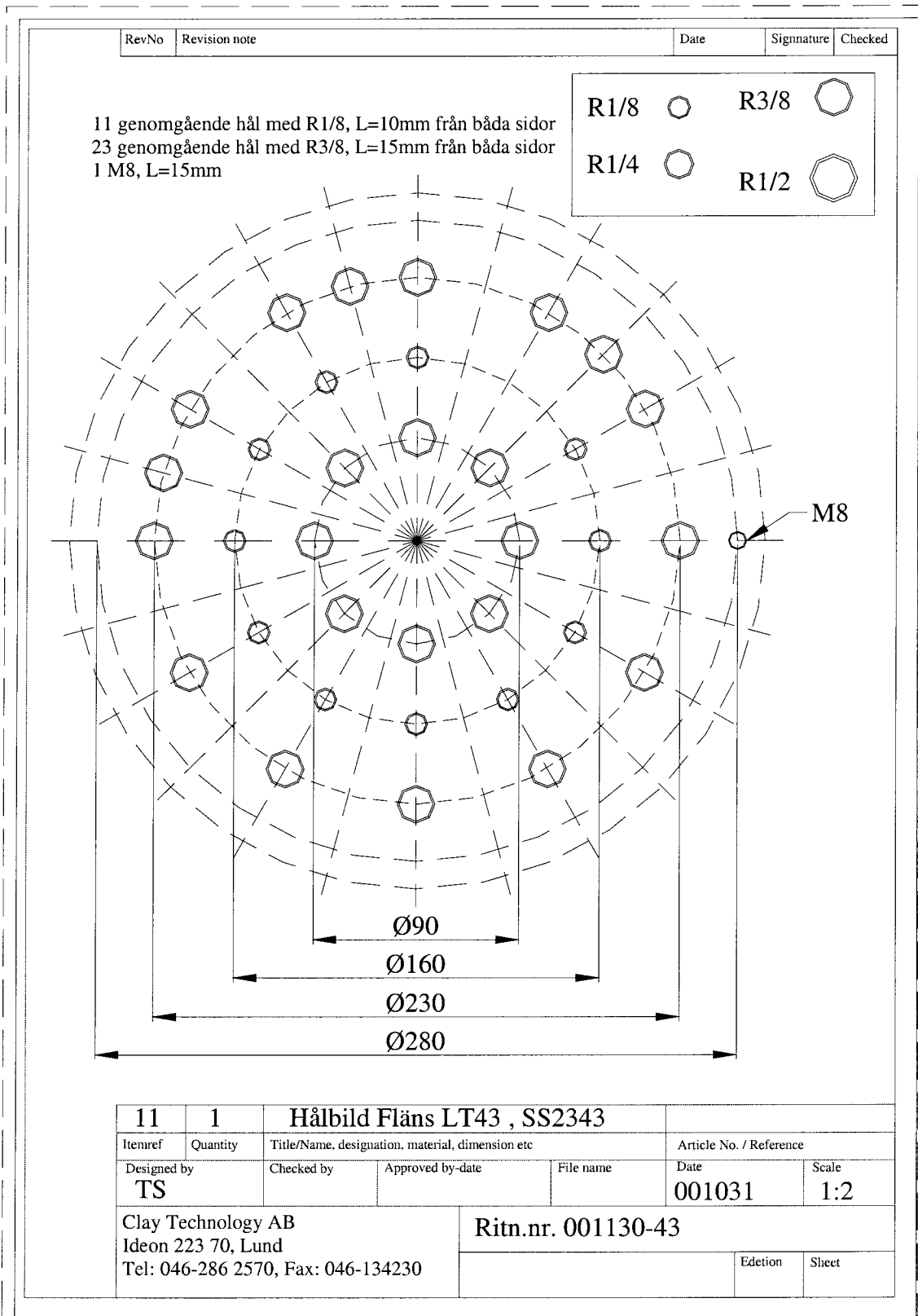

11	1	Hålbild Fläns LT43 , SS2343				
Itemref	Quantity	Title/Name, designation, material, dimension etc			Article No. / Reference	
Designed by TS		Checked by	Approved by-date	File name	Date 001031	Scale 1:2
Clay Technology AB Ideon 223 70, Lund Tel: 046-286 2570, Fax: 046-134230				Ritn.nr. 001130-43		
				Edition	Sheet	

APPENDIX 20

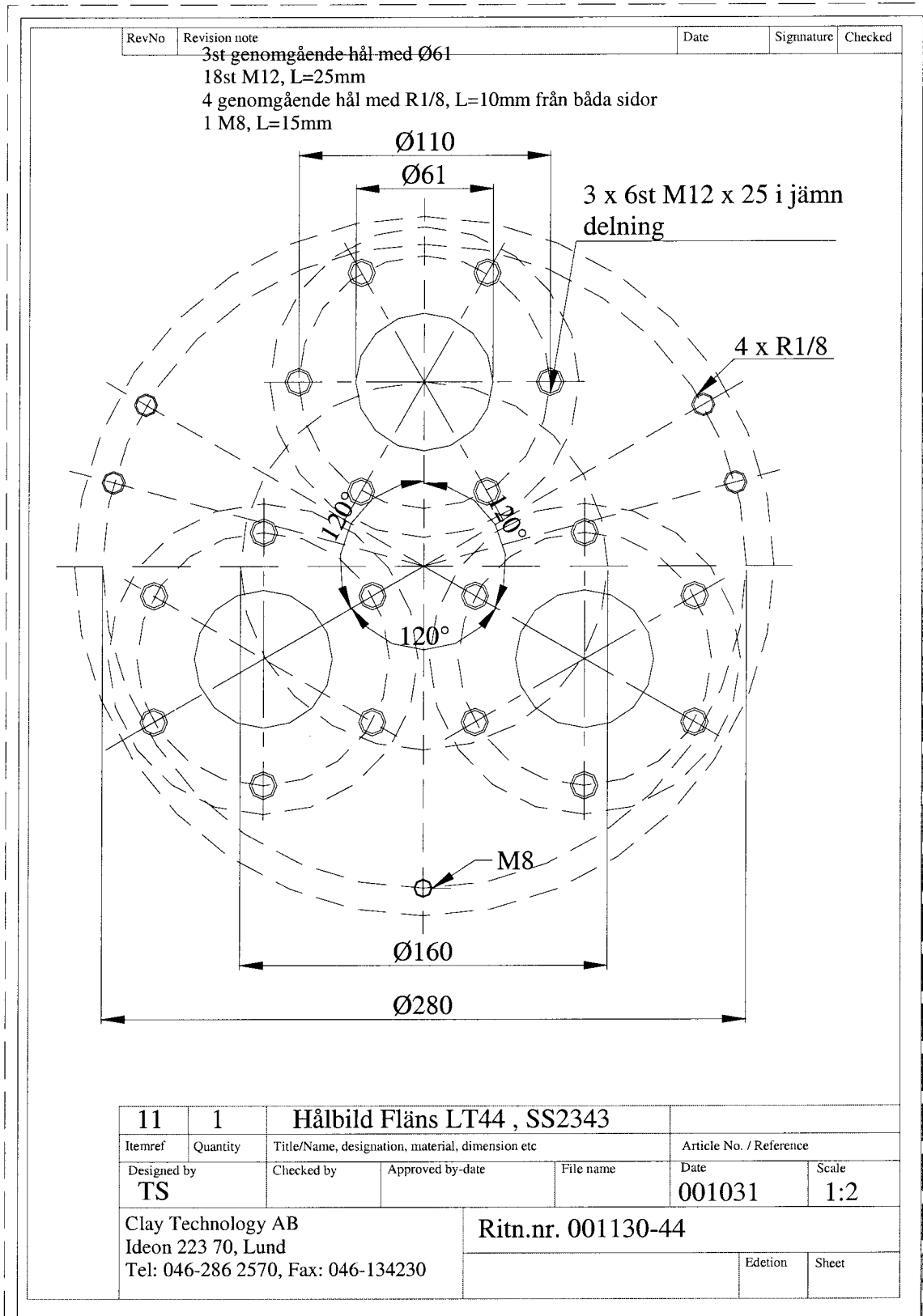

11	1	Hålbild Fläns LT44 , SS2343				
Itemref	Quantity	Title/Name, designation, material, dimension etc			Article No. / Reference	
Designed by	Checked by	Approved by-date	File name	Date	Scale	
TS				001031	1:2	
Clay Technology AB			Ritn.nr. 001130-44			
Ideon 223 70, Lund					Edetion	Sheet
Tel: 046-286 2570, Fax: 046-134230						

APPENDIX 21

16. MAJ 2000 (TIS) 11:55 ÖVERFÖRING NR: 46 SIDA 2

