

Oskarshamn site investigation

Complete chemical characterisation in KLX13A

**Results from two investigated borehole
sections: 432.0–439.2 m, 499.5–506.7 m**

Anette Bergelin, Kersti Nilsson, Anna Lindquist, Pia Wacker
Geosigma AB

August 2008

Svensk Kärnbränslehantering AB
Swedish Nuclear Fuel
and Waste Management Co
Box 250, SE-101 24 Stockholm
Tel +46 8 459 84 00



Oskarshamn site investigation

Complete chemical characterisation in KLX13A

Results from two investigated borehole sections: 432.0–439.2 m, 499.5–506.7 m

Anette Bergelin, Kersti Nilsson, Anna Lindquist, Pia Wacker
Geosigma AB

August 2008

Keywords: Groundwater, Measurements on line, In situ sampling, Measurements in situ, Redox potential, Dissolved gas, Humic and fulvic acids, Colloids, Laser Induced Breakdown Colloid Detection, Microbes, Chemical analyses, Isotope determinations, AP PS 400-06-075.

This report concerns a study which was conducted for SKB. The conclusions and viewpoints presented in the report are those of the authors and do not necessarily coincide with those of the client.

A pdf version of this document can be downloaded from www.skb.se.

Abstract

Complete chemical characterisation is the most extensive chemical investigation method performed in core drilled boreholes. The method entails pumping, measurements on-line and regularly water sampling for chemical analyses in isolated borehole sections during approximately three weeks per section at a flow rate of between 50 and 200 mL/min.

This report presents results from two sections in borehole KLX13A at 432.0–439.2 m borehole length (vertical depth 428 m) and 499.5–506.7 m borehole length (vertical depth 494 m). The results obtained include on-line measurements of redox potential, pH, dissolved oxygen, electrical conductivity and water temperature together with chemical analyses of major constituents, trace metals and isotopes. Furthermore, in section 432.0–439.2 m the gas content and composition were analysed as well as inorganic and organic colloids by fractionation and laser-induced breakdown colloid detection (LIBD). The investigation program in section 499.5–506.7 m was reduced due to the high amount of flushing water content.

The water compositions in sections 432.0–439.2 m and 499.5–506.7 m were relatively stable during the pumping and sampling periods. The chloride concentrations amounted to approximately 740 mg/l in both of the sections while the flushing water contents were relatively high; 9% and 16% respectively. The redox potentials for the borehole electrodes in both sections stabilised at about –280 to –290 mV.

The content of inorganic colloids in the water was very low or nonexistent with respect to silicon, manganese, sulphur and calcium. The presence of colloidal aluminium and iron is uncertain since contamination and precipitation have to be considered.

The LIBD and filtration results from section 432.0–439.2 m were in the same order of magnitude and suggest a colloid concentration of 2–5 µg/L and 12 µg/L respectively.

Sammanfattning

Fullständig kemikaraktisering är den mest omfattande kemiska undersökningsmetoden för kärnborrhål. Metoden innebär pumpning, mätning on-line och regelbunden vattenprovtagning för kemiska analyser i avgränsade borrhålssektioner under cirka tre veckor per sektion och vid ett pumpflöde på mellan 50 och 200 mL/min.

Denna rapport presenterar resultat från två sektioner i borrhålet KLX13A vid 432,0–439,2 m borrhålslängd (vertikalt djup 428 m) och vid 499,5–506,7 m borrhålslängd (vertikalt djup 494 m). Resultaten omfattar mätningar on-line av redox potential, pH, löst syre, elektrisk konduktivitet och vattentemperatur liksom kemiska analyser av huvudkomponenter, spårelement och isotoper. Vidare undersöktes sektion 432,0–439,2 m med avseende på innehåll av gaser och sammansättning samt oorganiska och organiska kolloider med fraktioneringsteknik och detektering genom laserinducerad nedbrytning (LIBD). Undersökningsprogrammet i sektion 499,5–506,7 m reducerades eftersom spolvattenhalten var hög.

Vattensammansättningen i sektionerna 432,0–439,2 m och 499,5–506,7 m var relativt stabil under pump/provtagningsperioderna. Kloridkoncentrationerna uppgick till ca 740 mg/l i både sektionerna medan spolvattenhalten var relativt höga; 9% respektive 16%. Redoxpotentialerna för borrhålelektrodena i respektive sektion stabiliserade sig på ca –280 mV till –290 mV.

Förekomsten av oorganiska kolloider befanns vara mycket låg eller obefintlig vad gäller kisel, mangan, svavel och kalcium. Förekomsten av kolloidalt aluminium och järn är osäker då kontaminering och utfällning kan påverka resultatet.

Resultatet från LIBD och kolloidfiltreringen i sektion 432,0–439,2 m indikerar en kolloidkoncentration på 2–5 µg/L respektive 12 µg/L.

Contents

| | | |
|-------------------|---|----|
| 1 | Introduction | 7 |
| 2 | Objectives and scope | 9 |
| 3 | Background | 11 |
| 3.1 | Flushing water history | 11 |
| 3.2 | Previous activities in the borehole | 12 |
| 3.3 | Choice of borehole sections | 12 |
| 4 | Equipment | 13 |
| 4.1 | The mobile field laboratory | 13 |
| 4.2 | Colloid filtering equipment | 14 |
| 5 | Performance | 17 |
| 5.1 | General | 17 |
| 5.2 | Chemical characterisation | 17 |
| 5.2.1 | Overview of field work procedure | 17 |
| 5.2.2 | Performance in section 432.0–439.2 m | 18 |
| 5.2.3 | Performance in section 499.5–506.7 m | 20 |
| 5.3 | Water sampling, sample treatment and analyses | 20 |
| 5.4 | Collection of in situ water samples | 21 |
| 5.5 | Colloid filtration | 21 |
| 5.6 | Nonconformities | 22 |
| 6 | Data handling and interpretation | 23 |
| 6.1 | Chemmac measurement data | 23 |
| 6.1.1 | Data file types and calculation software | 23 |
| 6.1.2 | Calculations and evaluation of pH and redox potential | 23 |
| 6.2 | Water analysis data | 24 |
| 6.3 | Data from special sampling methods | 26 |
| 6.3.1 | Colloid filtration | 26 |
| 6.3.2 | Dissolved gases | 26 |
| 7 | Results | 27 |
| 7.1 | Chemmac measurements | 27 |
| 7.2 | Water analyses | 28 |
| 7.2.1 | Basic water analyses | 28 |
| 7.2.2 | Trace elements (rare earth metals and others) | 32 |
| 7.2.3 | Stable and radioactive isotopes | 33 |
| 7.3 | Dissolved gas | 34 |
| 7.4 | Colloids | 35 |
| 7.4.1 | Inorganic colloids – colloid filtration | 36 |
| 8 | Summary | 41 |
| | References | 43 |
| | Appendices attached on CD | |
| Appendix 1 | Technical data Borehole KLX13A | |
| Appendix 2 | Selected results from differential flow logging in KLX13A | |
| Appendix 3 | Selected images from BIPS logging in KLX13A | |
| Appendix 4 | Measurement information, KLX13A | |
| Appendix 5 | Flow and pressure measurements in KLX13A | |
| Appendix 6 | Chemmac measurements in KLX13A, section 432.0–439.2 m | |

- Appendix 7** Chemmac measurements in KLX13A, section 499.5–506.7 m
- Appendix 8** Quantification of Colloids in Natural Groundwater from Laxemar Boreholes KLX13A and KLX17A
- Appendix 9** Sampling and analysis methods
- Appendix 10** Water analysis data, Compilation September 2007

1 Introduction

This document reports performance of and results from the activity *Complete hydrochemical characterisation* in the cored borehole KLX13A performed within the site investigation at Oskarshamn /1/. The work was conducted according to activity plan AP PS 400-06-075. The report presents hydrogeochemical data from field work carried out during the period of November 2006 to January 2007.

The controlling documents for the activity are listed in Table 1-1. The activity plan, the method description and the measurement system descriptions constitute SKB's internal controlling documents. The obtained data from the activity are reported to the SICADA database and are traceable by the activity plan number. Sampling for microbe studies, was also performed within the present activity in borehole section 432.0–439.2 m. The microbe investigations will be reported in a separate primary data report /2/.

Borehole KLX13A is a 595.9 m long telescopic borehole drilled at Laxemar and inclined 82° from the horizontal plane. The interval 0–100 m is percussion drilled with a diameter of approximately 200 mm and the interval 100–596 m is core drilled with a diameter of 76 mm. The percussion borehole HLX14 served as the source of flushing water for the drilling of KLX13A. The locations of KLX13A and HLX14 are shown in Figure 1-1. The borehole design of KLX13A is presented in Appendix 1. The borehole is of the so-called SKB chemical-type, see method descriptions MD 620.003 (Method description for drilling cored boreholes) and MD610.003 (Method description for percussion drilling). An SKB chemical-type borehole requires that cleaning procedures are carried out on all downhole equipment to be used in the borehole, both during and after drilling, according to level 2 in the cleaning instructions outlined in MD 600.004 (Instruktion för rengöring av borrhålsutrustning och viss markbaserad utrustning).

Table 1-1. Controlling documents for the performance of the activity.

| Activity plan | Number | Version |
|---|--|--------------------------|
| Fullständig kemikaraktärisering med mobilt fältlaboratorium i KLX13A. | AP PS 400-06-075 | 1.0 |
| Method description | Number | Version |
| Metodbeskrivning för fullständig kemikaraktärisering med mobilt fältlaboratorium. | SKB MD 430.017 | 2.0 |
| Measurement system descriptions | | |
| Instruktion för rengöring av borrhålsutrustning och viss markbaserad utrustning. | SKB MD 600.004 | 1.0 |
| Mätssystembeskrivningar för mobil kemienhet allmän del, slangvagn, borrhålsutrustning, mobil ytChemmac och dataapplikation. | SKB MD 434.004 SKB MD 434.005 SKB MD 434.006 SKB MD 434.007 SKB MD 434.018 | 1.0 1.0 1.0 1.0 |
| Mätssystembeskrivning för kolloidfiltreringssystem | SKB MD 431.045 | In progress |
| Instructions | | |
| Provtagning och analys-kemilaboratorium | SKB MD 452.001-019 | – |

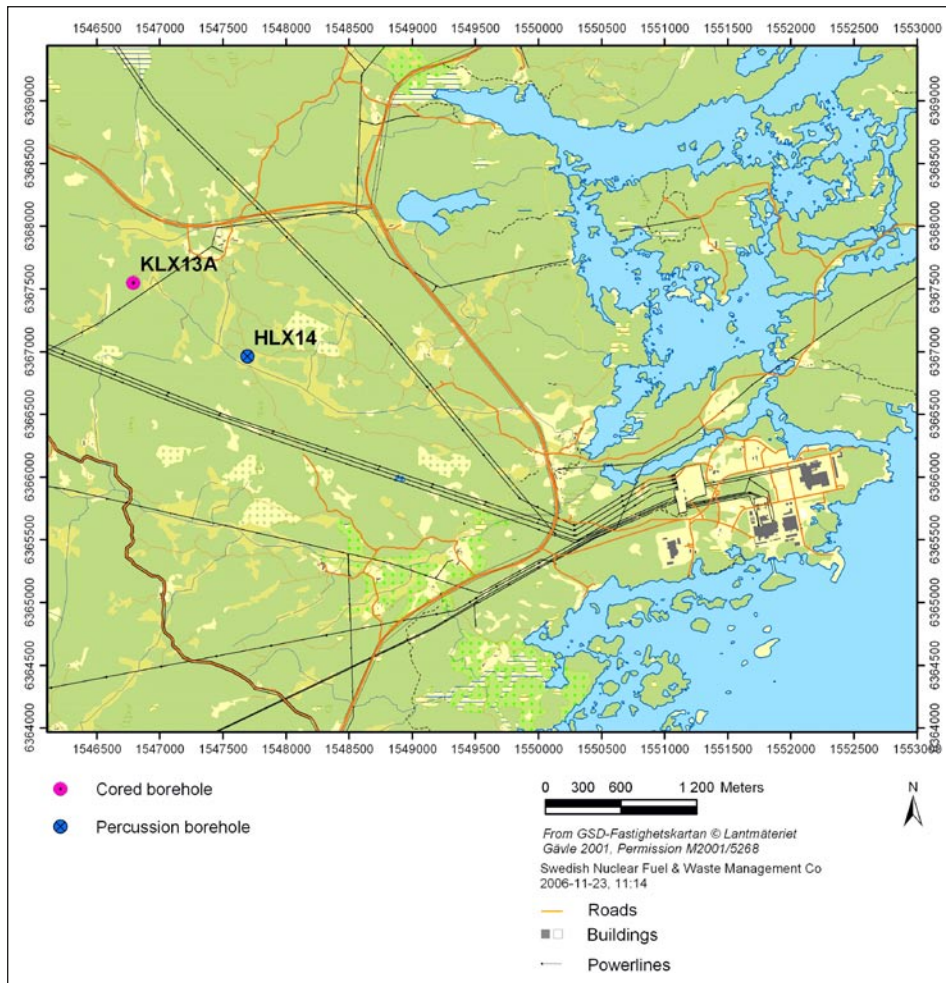

Figure 1-1. Locations of the core drilled borehole KLX13A and the percussion borehole HLX14 within the site investigation at Oskarshamn.

2 Objectives and scope

Complete chemical characterisation is the most extensive chemical investigation method performed in core-drilled boreholes. The method is carried out in order to obtain as complete information as possible about the groundwater chemical conditions in individual water-bearing fractures or local minor fracture zones. Considerable effort is made to obtain representative samples from a limited rock volume. Careful pumping and continuous control of the pressure in the sampled borehole section, as well as above the section, is maintained in order to minimise the risk of mixing with ground waters from other fracture systems.

The analytical programme was carried out according to SKB chemistry class 4 and class 5 including all options /1/. Furthermore, pH, redox potential (Eh) and water temperature were measured in flow-through cells downhole as well as at the ground surface. The flow-through cell at the surface also measured electrical conductivity and dissolved oxygen. In addition, samples were collected in situ in borehole section 432.0–439.2 m for determination of gas content and composition, microbe content and their characterisation as well as for determination of colloid content by fractionation and LIBD techniques. Due to high concentrations of flushing water in the investigated sections, enrichment and fractionation of humic and fulvic acids were cancelled.

3 Background

3.1 Flushing water history

The core drilling of the 595.9 m long borehole consumed 782 m³ of flushing water and the volume of returned water pumped from the borehole by air-lift pumping during drilling was 4,001 m³.

Uranine was added automatically to the tank with flushing water that supplies flushing water to the drilling head. The Uranine concentration in the flushing water and returned water was checked regularly and a total of 107 samples of each sample type were analysed. The Uranine concentrations in the flushing water and in the returned water are presented in Figure 3-1. A water budget, presenting the amount of Uranine added to the borehole via the flushing water and the estimated amount recovered in the return water, is given in Table 3-1.

Table 3-1. Amount of Uranine added to KLX13A via the flushing water during core drilling and the amount recovered from the air-lift pumping.

| Uranine | (g) |
|---|-----|
| Added, calculated from the average Uranine concentration added and the total volume of flushing water. | 171 |
| Recovered, estimated from the average Uranine concentration recovered and the total volume of returned water. | 280 |

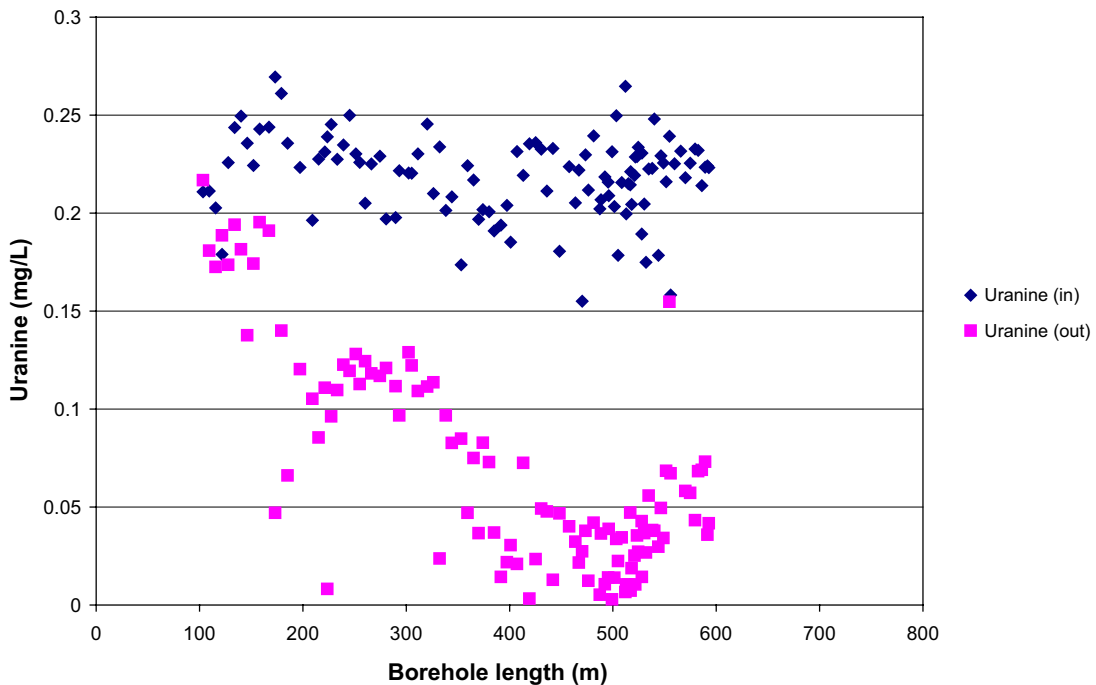

Figure 3-1. Uranine concentrations in the flushing water and in the recovered water versus borehole length.

The Uranine budget in Table 3-1 suggests that no flushing water has been lost to the borehole and the adjacent host bedrock during drilling, which is unusual. As a higher amount of Uranine cannot be recovered from the borehole than added to it, the calculation using average values has in this borehole resulted in an unacceptably high unreliability.

Detailed information on the flushing water and drilling of the borehole can be obtained from the drilling report /3/.

3.2 Previous activities in the borehole

KLX13A is a SKB chemistry-type core borehole intended for *Complete chemical characterisation*. Only activities that are necessary in order to select borehole sections are carried out in the borehole prior to the chemistry campaign. The more downhole equipment used in the borehole, the greater is the risk of contamination and affects on, for example, the in situ microbiological conditions. The activities/investigations performed in KLX13A prior to the chemistry campaign are listed in Table 3-2 below.

3.3 Choice of borehole sections

The main objective for the *complete chemical characterisation* in KLX13A was to investigate one section at repository depth (c. 400–510 m). The differential flow logging /7/ revealed five water-bearing zones (> 10,000 mL/h) within this borehole interval. Furthermore, eight sections with water yield just below 10,000 mL/h were identified within the preferred depth interval.

The section at 499.5–506.7 m was selected since it fulfilled all requirements (flow yield > 10,000 mL/h, near repository depth and suitable for the positioning of the packers). However, since the flushing water content was high, section 499.5–506.7 m was abandoned after about 14 days of pumping and section 432.0–439.2 m was selected for its lower hydraulic transmissivity, in order to possibly lower the amount of flushing water. However, the water flow from the section was higher than expected from the differential flow logging results and after several weeks of pumping the flushing water content was still high. The pumping was carried out without any significant drawdown.

Table 3-2. Activities performed in KLX13A prior and in connection to the chemical characterisation.

| Activity | Date of completion | Length or section (m) | Comment |
|----------------------------------|--------------------|-----------------------|---------|
| Percussion drilling | 2006-06-30 | 0.15–99.86 | |
| Core drilling | 2006-08-16 | 99.86–595.85 | |
| Hydrochemical logging | 2006-09-19 | 0–585 | /4/ |
| BIPS-logging | 2006-08-10 | 380–545.15 | /5/ |
| Nitrogen lifting of water column | 2006-09-07 | 0–595.85 | |
| Geophysical logging | 2006-09-08 | 101.2–592.8 | /6/ |
| Differential flow logging | 2006-09-26 | 95–585 | /7/ |

4 Equipment

4.1 The mobile field laboratory

The mobile field laboratories used by SKB for water sampling and downhole measurements consist of a laboratory unit, a hose unit with downhole equipment and a Chemmac measurement system, Figure 4-1; the system is presented schematically in Figure 4-2. It is also possible to include a separate unit for computer work (MYC). The different parts of the system are described in the SKB internal controlling documents SKB MD 434.004, 434.005, 434.006, 434.007 and SKB MD 433.018 (Mätsystembeskrivningar för mobil kemienhet allmän del, slangvagn, borrhålsutrustning, mobil ytChemmac och dataapplikation).

The Chemmac measurement facilities include communication systems, measurement application and flow-through cells with electrodes and sensors at the ground surface (surface Chemmac) and downhole (borehole Chemmac).

The downhole equipment comprises inflatable packers, pump, borehole Chemmac and the in situ sampling unit (PVP), allowing measurement (borehole Chemmac) and sampling in situ in the borehole section (PVP sampling unit). The four sampled portions of ground-water collected with the PVP sampling unit maintain the pressure from the borehole section when raised to the surface. The portions are used for colloid and gas analysis and microbe investigations.

The mobile units used for the investigation of borehole KLX13A consisted of the hose unit S2, the laboratory unit L2 and the computer unit MYC 2 including surface Chemmac.



Figure 4-1. The mobile units used at KLX13A; from left container for collecting the water from the borehole, laboratory unit, hose unit with downhole equipment and a unit for computer work.

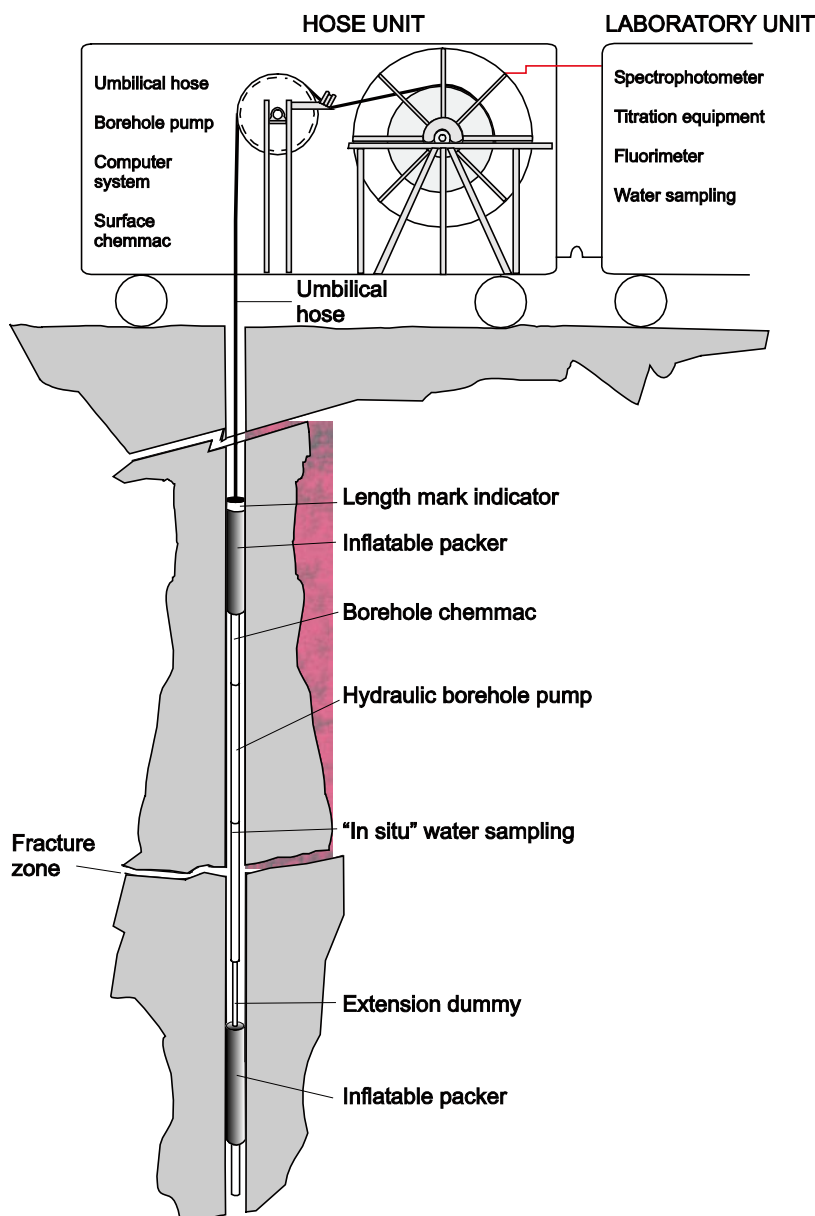

Figure 4-2. The mobile laboratory including laboratory unit, hose unit and downhole equipment. The configuration of the downhole units in the borehole can be varied depending on desired section length. However, the *in situ* water sampler must always be positioned first in the sample water path.

4.2 Colloid filtering equipment

The equipment is adapted to the sample containers (PVB) from the PVP water sampling unit. The colloid filtering equipment consists of holders for two PVB-containers, a separated tube and valve system for water and gas, a filter holder package for five filters, and a collecting container. The equipment is described in SKB MD 431.045 (Mätssystembeskrivning för kolloidfiltrerings-system, handhavandedel (SKB internal controlling document to be published)). Note that the pore sizes of the five connected filters have been changed to 2, 2, 0.4, 0.2 and 0.05 μm . The pore sizes have been reduced because previous analyses have indicated an absence of large colloidal particles. Figure 4-3 shows the equipment setup.

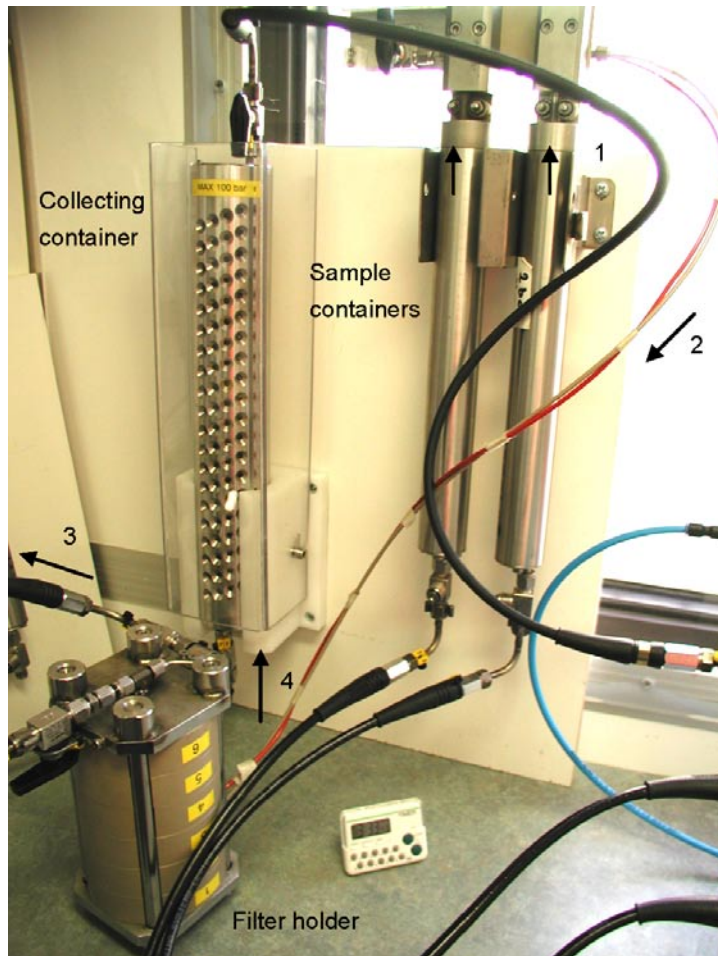

Figure 4-3. The colloid filtering equipment including the sample containers, the filter holder package and the collecting container. The black arrows, 1 to 4, show the flow direction of the sample water through the system.

The major equipment features are:

- Filtering is performed in a closed system under an argon atmosphere, thus avoiding the risk of iron precipitation due to contact between the groundwater sample and air.
- Filtering is performed at a pressure similar to that of the groundwater in the borehole section. The system is adjusted to create a pressure difference between the inlet of the filter package and the outlet side. The pressure difference drives the sample water through the filters.
- The design of the sample containers, and the mounting with the outlet at the top, prevents migration of larger particles that might clog the filters. Furthermore, clogging is prevented by the first two filters with pore sizes 2 μm which are mounted parallel to each other.

A source of possible contamination is the PVB sample containers that are made of stainless steel. An improvement could be to use Teflon coating on the insides of the cylindrical containers.

5 Performance

5.1 General

Chemical characterisation in borehole KLX13A was conducted according to activity plan AP PS 400-06-075 following the method described in SKB MD 430.017 (Metodbeskrivning för fullständig karakterisering med mobilt fältlaboratorium).

Table 5-1 gives an overview of the investigation sequence in KLX13A.

The investigation began in section 499.5–506.7 m followed by section 432.0–439.2 m. Due to high flushing water content in section 499.5–506.7 m, the pumping was interrupted before completion of the investigation programme and the equipment was moved to section 432.0–439.2 m. Enrichment and fractionation of humic and fulvic acids were excluded in both sections since the flushing water content exceeded 5%.

5.2 Chemical characterisation

5.2.1 Overview of field work procedure

A short chronological summary of the different steps that constitute chemical characterisation of groundwater in a borehole section is given below. Preparations before the downhole equipment is lowered in the borehole include:

- Cleaning of the inside of the umbilical hose (the sample water channel) with de-ionised and de-oxygenated water. Finally, the sample water channel is filled with de-ionised and de-oxygenated water prior to lowering.
- Cleaning and preparation of the four sample containers (PVB) belonging to the in situ water sampling unit (PVP). The containers are cleaned on the outside using 70% denatured ethanol and on the inside using chlorine dioxide. One of the containers is used for microbe sampling and sterile conditions are desirable. The containers are purged with nitrogen gas and a small nitrogen gas pressure is maintained in the containers. The magnitude of the pressure depends on the depth of the section to be sampled.
- Calibration of the pH and redox electrodes in the borehole Chemmac.

Table 5-1. Investigation sequence in KLX13A.

| Start date/ Stop date | Section (m) | Comment |
|---------------------------|-------------|---|
| 2006-11-20/ 2006-12-12 | 499.5–506.7 | Pumped volume = 6.7 m ³ Flow rate approx. 160–260 mL/min Interrupted investigation |
| 2006-12-13/ 2007-01-22 | 432.0–439.2 | Pumped volume = 7.9 m ³ Flow rate approx. 125 mL/min |

The different downhole units are assembled during lowering of the equipment in the borehole and the following steps are taken:

- The outside of the umbilical hose is cleaned with 70% denatured ethanol (SKB MD 600.004).
- Calibration of the umbilical hose length is conducted at least once for each borehole. For this, a length mark detector unit (caliper) is mounted together with the downhole equipment. The length mark detector indicates length calibration marks milled into the borehole wall at almost every 50 m along the borehole. At each indication, a reading is made of the corresponding length mark on the umbilical hose. The correct distance to each length mark is obtained from the SICADA database.

When the pump is started and the packers are inflated at the desired positions in the borehole, a pumping and measurement period begins. Typical measures taken and activities carried out during this period are:

- Calibration of the pH and redox electrodes as well as the electrical conductivity and oxygen sensors in the surface Chemmac is conducted when the pumped water from the borehole section has reached the surface.
- Careful attention is paid to ensure that the packed off section is well isolated from the rest of the borehole. A significant drawdown in the section during pumping is one indication that the section is properly sealed off. Leakage would cause pumping of water from the borehole column above and/or below the packers and not only from the fracture zone of interest. However, the drawdown in the borehole section must not be too large, because the greater the drawdown, the larger the bedrock volume affected by the pumping and the risk of mixing with groundwater from other shallower and/or deeper fracture systems increases. The pumping flow rate is adjusted depending on the flow yield from the fracture or fracture zone (to between 50 and 300 mL/min) and maintained more or less constant during the pumping and measurement period.
- Water samples are collected regularly once or twice a week during the pumping period. Changes in water composition are monitored by pH and conductivity measurements and by immediate analyses (pH, Uranine, chloride, alkalinity, ammonium, ferrous and total iron).
- A decision when to terminate the sampling work in the section is made during a suitable stage of the pumping and measurement period. The investigation might be prolonged if the concentration of flushing water exceeds 1% or if the redox potential measurements have not reached stable values. A final SKB Class 5 sample including all options is collected the day before termination.

Completion of the investigation in the section and lifting of the downhole equipment entails:

- Collection of in situ samples prior to lifting the equipment. The valves to the PVB sampling containers in the borehole section are opened in order to rinse the system and fill the containers. After a few hours the valves are closed and the water sample portions for analyses of colloids, dissolved gases and microbes are secured.
- Following stopping of the borehole pump and deflation of the packers, the equipment is lifted and the different downhole units are dismantled.
- Calibration of the electrodes in the borehole Chemmac and surface Chemmac.

The following sections (5.2.2–5.2.3) shortly describe the performance in each section.

The main activities are presented in the events tables together with SKB sample numbers of the corresponding water samples.

5.2.2 Performance in section 432.0–439.2 m

The chemical characterisation in section 432.0–439.2 m was performed using the following configuration of the downhole equipment in the borehole. From the top: umbilical hose, length mark detector, borehole Chemmac, upper packer, borehole pump, in situ water sampler (PVP),

and lower packer, see Appendix 4. The pressures above and within the section were measured by the borehole Chemmac unit and the PVP water sampling unit, respectively.

The pumping flow rate was about 125 mL/min and the drawdown negligible at the end of the measurement period. Diagrams showing the pressures above and within the borehole section and the flow rate during the pumping/measurement period are presented in Appendix 5. The events during the investigation are listed in Table 5-2.

Table 5-2. Events during the pumping/measurement period in section 432.0–439.2 m.

| Date | Event | Sample no. |
|-------------|---|-------------------|
| 061212 | Change of membranes and cleaning of oxygen electrode Lowering of downhole equipment S2 (432.00–439.16 m) Start of borehole pump and Chemmac measurements Pumping interrupted due to malfunction of the borehole pump (defect spring). Rising of equipment and repair of borehole pump. Calibration of borehole Chemmac | |
| 061213 | Lowering of downhole equipment S2 (432.00–439.16 m) Start of borehole pump and Chemmac measurements | |
| 061214 | Calibration of surface Chemmac Restart of measurement application due to large variations in the water flow Water sampling: SKB class 2 | 11545 |
| 061218 | Water sampling: SKB class 4 | 11546 |
| 061221 | Water sampling: SKB class 4 | 11547 |
| 070102 | Water sampling: Uranine | 11549 |
| 070104 | Water sampling: SKB class 5; Ra/Rn were not analysed. | 11550 |
| 070108 | Water sampling: SKB class 5 | 11606 |
| 070111 | Water sampling: SKB class 5; Ra/Rn were not analysed. | 11607 |
| 070114 | Power failure due to storm. Borehole pump stopped. | |
| 070115 | Borehole pump and measurement application restarted with backup power supply. | |
| 070116 | Water sampling: Uranine | 11608 |
| 070117 | Water sampling: SKB class 5 Water sampling: SKB class 5, control sample Connection of power supply PVP-sampler: opening of valve at 15:16 | 11609 11610 |
| 070118 | PVP-sampler: closure of valve at 07:07 Sampling for microbes, colloids and dissolved gases End of Chemmac measurements Lifting Lowering of downhole equipment S2 (432.00–439.16 m) Start of borehole pump and Chemmac measurements Calibration of borehole Chemmac | 11609 |
| 070119 | Calibration of surface Chemmac Restart of measurement application after calibration Colloid filtration | |
| 070121 | Power failure, restart of measurement application | |
| 070121 | PVP-sampler: opening of valve at 20:37 Sampling for colloids and dissolved gases | 11609 |
| 070122 | PVP-sampler: closure of valve at 07:09 End of Chemmac measurements Lifting Water sampling: SKB class 5. Sampling of water from the umbilical hose about 2–3 hours after pumping (Ra/Rn were not analysed). | 11611 |

5.2.3 Performance in section 499.5–506.7 m

The chemical characterisation in section 499.5–506.7 m was performed using the following configuration of the downhole equipment in the borehole. From the top: umbilical hose, length mark detector, borehole Chemmac, upper packer, borehole pump, in situ water sampler (PVP), and lower packer, see Appendix 4. The pressures above and within the section were measured by the borehole Chemmac unit and the PVP water sampling unit, respectively.

The pumping flow rate was about 160–260 mL/min and the drawdown approximately 0.4 m at the end of the measurement period. Diagrams showing the pressures above and within the borehole section and the flow rate during the pumping/measurement period are presented in Appendix 5. The events during the investigation are listed in Table 5-3.

Table 5-3. Events during the pumping/measurement period in section 499.5–506.7 m.

| Date | Event | Sample no. |
|--------|---|------------|
| 061115 | Lowering of downhole equipment S2 (499.50–506.66 m) Pumping interrupted due to malfunction of length mark detector and loss of contact with borehole Chemmac. Repair of length mark detector and substitution of borehole Chemmac | |
| 061120 | Lowering of downhole equipment (499.50–506.66 m) Calibration of borehole Chemmac Start of borehole pump and Chemmac measurements | |
| 061121 | Calibration of surface Chemmac Water sampling: SKB class 2 | 11536 |
| 061123 | Water sampling: SKB class 4 | 11537 |
| 061127 | Water sampling: Uranine | 11538 |
| 061128 | Water sampling: SKB class 4 | 11541 |
| 061130 | Water sampling: SKB class 4 Decrease of water flow rate. Broken spring in the borehole pump at 20:30. | 11542 |
| 061204 | Water sampling: Uranine | 11543 |
| 061211 | Water sampling: SKB class 5. (samples for TOC, ⁸⁷ Sr, ³⁷ Cl, ^δ ¹³ C, ¹⁴ C, ³⁴ S, U/Th were stored in freezer and refrigerator) | 11544 |
| 061212 | End of Chemmac measurements Lifting Calibration of borehole Chemmac | |
| 061214 | Calibration of surface Chemmac | |

5.3 Water sampling, sample treatment and analyses

The pumped water from the borehole section is led from the hose unit into the laboratory unit where sampling and sample filtration is carried out. Filtration of sample portions is performed on-line by connecting the filter holders directly to the water outlet. A water sample is defined as groundwater collected during one day and consists of several sample portions, labelled with the same sample number.

An overview of sample treatment and analysis methods is given Appendix 9. The routines are applicable independently of sampling method or type of sampling object.

5.4 Collection of in situ water samples

The in situ water sampling was conducted successfully in section 432.0–439.2 m. The sampling was repeated in order to obtain additional samples for colloid determination using Laser Induced Breakdown Detection (LIBD), see Appendix 8. Furthermore, dissolved gases were analysed by two independent laboratories. The purpose of each sample portion is given in Table 5-4.

The in situ sampling in section 499.5–506.7 m was excluded due to the high content of remaining flushing water.

The PVB containers were all quality controlled before use. This procedure includes disassembling the container, thorough cleaning, re-assembling and measurement of piston friction. The filled PVB containers were packed together with ice packs in insulated bags and sent to the laboratories by express delivery service immediately after sampling.

5.5 Colloid filtration

Colloid filtration was performed in section 432.0–439.2 m. The method for sampling of colloids in groundwater entails filtering the groundwater through a series of connected filters in a closed system under an argon atmosphere. The pressure in the system is maintained at the same level as the pressure in the sampled borehole section. The intention is that colloids should be collected on the different filters (descending pore sizes) according to their sizes. Two of the four sample portions collected in situ in each borehole section are used for colloid filtration. Data on performance of the filtration runs are given in Table 5-5.

To check the validity of the approach, a test was performed using two different commercial Latex Microsphere Suspensions containing particles with pore sizes of 0.08 μm and 0.24 μm , respectively. The filters were weighed before and after filtering (and drying to stable weight) of a suspension containing 0.1 mg of each pore size, at a pressure of 10 bars. The weights increased on the 0.4 μm and 2.0 μm filters (on which neither of the commercial colloids should be present) and were rather high (0.03–0.09 mg). The weights on the 0.2 μm and 0.05 μm filters were also somewhat too high, 0.17 and 0.20 mg, respectively. Despite the weight increase that may be due to a minor water uptake, the test indicates that the total amount of synthetic colloids that passed through the tubing and valve system were collected on the intended filters.

Table 5-4. Collection and purpose of in situ water sample portions.

| Sample portion no. | Section 432.0–439.2 m 2007-01-18 | Section 432.0–439.2 m 2007-01-22 |
|--------------------|---------------------------------------|---------------------------------------|
| 1 | Dissolved gas (Lab 2), N ₂ | Dissolved gas (Lab 1), N ₂ |
| 2 | Microbes | Colloids (LIBD) |
| 3 | Colloids | Colloids (LIBD) |
| 4 | Colloids | – |

Table 5-5. Colloid filtration, data on performance.

| Section/date | Entering pressure [bar] | Max. differential pressure over filter package [bar] | Temp. [°C] | Filtering time [min] | Filtered volume [ml] | Comments |
|----------------------------|-------------------------|--|------------|----------------------|----------------------|---|
| 432.0–439.2 m /20070118 | ~44 | 3.6 | ~12 | 51 | 307 | Leakage test prior to filtration. No leakage was noticed. |

A leakage test of the system at 10 bars was also done prior to the sampling in order to eliminate the risk of leakage. If no leakage was detected, the system was dried and assembled.

Each filtration results in five filter samples (two 2 µm, one 0.4 µm, one 0.2 µm and one 0.05 µm filter pore sizes) and two water samples (water in and water out). All samples were sent for ICP analyses (major constituents and common trace metals).

5.6 Nonconformities

The *Complete chemical characterisation* in KLX13A has been conducted according to the SKB internal controlling documents AP PS 400-06-075 and SKB MD 430.017 with the following deviations and remarks:

- The allowed upper limit for flushing water content, 1%, was exceeded in both of the sections; 432.0–439.2 m (9%) and 499.5–506.7 m (16%).
- Sample no. 11611 in borehole section 432.0–439.2 was sampled from the umbilical hose about 2–3 hours after stopping the borehole pump.
- The investigation programme in section 499.5–506.7 m was reduced due to high amounts of flushing water; in situ sampling for colloids, gases and microbes as well as enrichment and fractionation of humic and fulvic acids were cancelled.
- Enrichment and fractionation of humic and fulvic acids in section 432.0–439.2 m was excluded due to high content of flushing water.
- The in situ sampling in section 432.0–439.2 m was repeated once in order to collect sample portions for analysis of colloids using Laser Induced Breakdown Detection (LIBD). Furthermore, dissolved gases were analysed by two independent laboratories.
- Some equipment malfunctions were encountered during the investigation:
 - defective spring in borehole pump,
 - defective length mark detector,
 - loss of connection with the borehole Chemmac.

6 Data handling and interpretation

6.1 Chemmac measurement data

The processing of Chemmac data are described in SKB MD 434.007-02 (Mätssystembeskrivning för Chemmac mätsystem, SKB internal controlling document, in progress).

6.1.1 Data file types and calculation software

The on-line measurements in a borehole section produce the following types of raw data files:

- Calibration files from calibration measurements (*.CRB) and corresponding comment files (*.CI). The files are used for calculation of calibration constants (pH and Eh) and the calibration factor (electrical conductivity). For surface Chemmac ten *.CRB and ten *.CI files are produced, and for borehole Chemmac six *.CRB and six *.CI files.
- Raw data file containing the logged measurements from the borehole section and the surface (*K.MRB) as well as a corresponding comment file (*.MI). The logged voltage values need to be converted to pH and Eh values (also in mV) using the calibration constants obtained from calibration.
- Measurement file including equipment and environment parameters (*O.MRB), such as power consumption in the downhole Chemmac unit and temperature inside the hose unit.

The original raw data files listed above are stored in the SICADA file archive. Furthermore, the files are re-calculated and evaluated to obtain pH and redox potential values and to correct the electrical conductivity values using the specially designed calculation software (Hilda). The resulting files containing calculated and evaluated values as well as comments on the performance are:

- A file **constants.mio* containing all the calculated calibration constants (one constant for each electrode in each buffer solution). The file is stored in the SICADA file archive and is useful in order to follow the development of single electrodes.
- A file **measurements.mio* containing the calculated and evaluated measurement values (pH, redox potential, electrical conductivity and water temperature). The data from the file are exported to the data tables “redox” and “ph_cond” in SICADA. As the file also contains some measured parameters that are not included in the tables mentioned above (e.g. pressure registrations) the complete file is also stored in the SICADA file archive.
- A file **comments.mio* containing comments on the field work and the calculation/evaluation. The comments in the file are imported as activity comments in SICADA.

6.1.2 Calculations and evaluation of pH and redox potential

The redox potential is measured by three electrodes at the surface and three in the borehole section. In addition, pH is measured by two electrodes at the surface and two in the borehole section. The registrations by the redox and the pH electrodes are logged each hour during a measurement period of approximately three weeks and a calibration is performed before and after the measurement period. The treatment of the raw data includes the following steps:

- Calculation and choice of calibration constants.
- Calculation of one pH and one redox potential sequence for each electrode (i.e. three or six redox electrodes and two or four pH electrodes).
- Determination of representative pH and redox potential values as well as estimated measurement uncertainties for the investigated borehole section.

One calibration constant is selected for each electrode using one of the following alternatives:

- Case 1: Calculation of the average calibration constant value and the standard deviation. The initial and the final calibration measurements results in four constants for each redox electrode (in pH 4 and pH 7 buffer solutions) and six constants for each pH electrode (in pH 4, 7 and 10 buffer solutions).
- Case 2: The calibration constant obtained from the initial calibration measurement at pH 7 is selected since it is closest to the pH of the borehole water. This alternative is chosen if the calibration constants obtained in the different buffers show a large variation in value (generally a difference larger than 20 mV between the highest and the lowest value). The standard deviation is calculated in the same way as in Case 1.
- Case 3: If the final calibration constants turn out to be very different (more than 20 mV) from the initial constants, a linear drift correction is needed. The reason is most often a drift in the reference electrode. The values and standard deviations are calculated for the initial and the final calibration constants separately and a linear correction is made between the selected initial and the selected final constant. The higher of the two standard deviation values is used in the estimation of the total measurement uncertainty.

The values in the measurement raw data file are converted to pH and Eh measurement sequences for each pH and redox electrode using the calibration constant selected as stated above.

The next step is to choose a logging occasion in a stable part of the measurement period and select a representative result for each electrode. The average values are calculated for each electrode group in order to obtain one representative value of redox potential, pH (borehole Chemmac) and pH (surface Chemmac), respectively. Obviously erroneous electrodes are omitted. The corresponding total measurement uncertainties are estimated using the standard deviations of the calibration constants and the standard deviations of the Eh and the pH values obtained by the different sets of electrodes. It is useful to evaluate pH at the surface and pH in the borehole section separately, since pH in the pumped water might differ from the pH measured in the borehole section. This is due to changing gas pressure conditions and its effects on the carbonate system.

Factors considered when evaluating the measurement uncertainties in pH and redox potential (Eh) values are:

- Difference in calibration constants for each electrode and calibration/buffer solution.
- Drift in calibration constants between the initial and the final calibration.
- Stability in voltage value during the final part of the on-line measurement. A successful measurement shows no tendency of a slope.
- Agreement between the different pH and redox electrodes on the surface and in the down-hole borehole Chemmac.
- Number of electrodes showing reasonable agreement. Obviously erroneous electrodes are excluded from the calculation.

6.2 Water analysis data

The following routines for quality control and data management are generally applied for hydrogeochemical analysis data, independently of sampling method or sampling object.

Some components are determined by more than one method and/or laboratory. Moreover, duplicate analyses by an independent laboratory are performed as a standard procedure on each fifth or tenth collected sample. All analytical results are stored in the SICADA database. The applied hierarchy path "Hydrochemistry/Hydrochemical investigation/Analyses/Water in the database" contains two types of tables, raw data tables and primary data tables (final data tables).

Data on *basic water analyses* are inserted into the raw data tables for further evaluation. The evaluation results in a final reduced data set for each sample. These data sets are compiled in a primary data table named “water composition”. The evaluation is based on:

- Comparison of the results from different laboratories and/or methods. The analyses are repeated if a large disparity is noted (generally more than 10%).
- Calculation of charge balance errors according to the equation below. Relative errors within $\pm 5\%$ are considered acceptable (in surface waters $\pm 10\%$).

$$\text{Relative error (\%)} = 100 \times \frac{\sum \text{cations (equivalents)} - \sum \text{anions (equivalents)}}{\sum \text{cations (equivalents)} + \sum \text{anions (equivalents)}}$$

- General expert judgement of plausibility based on earlier results and experience.

All results from *special analyses of trace metals and isotopes* are inserted directly into primary data tables. In those cases where the analyses are repeated or performed by more than one laboratory, a “best choice” notation will indicate those results which are considered most reliable.

An overview of the data management is given in Figure 6-1.

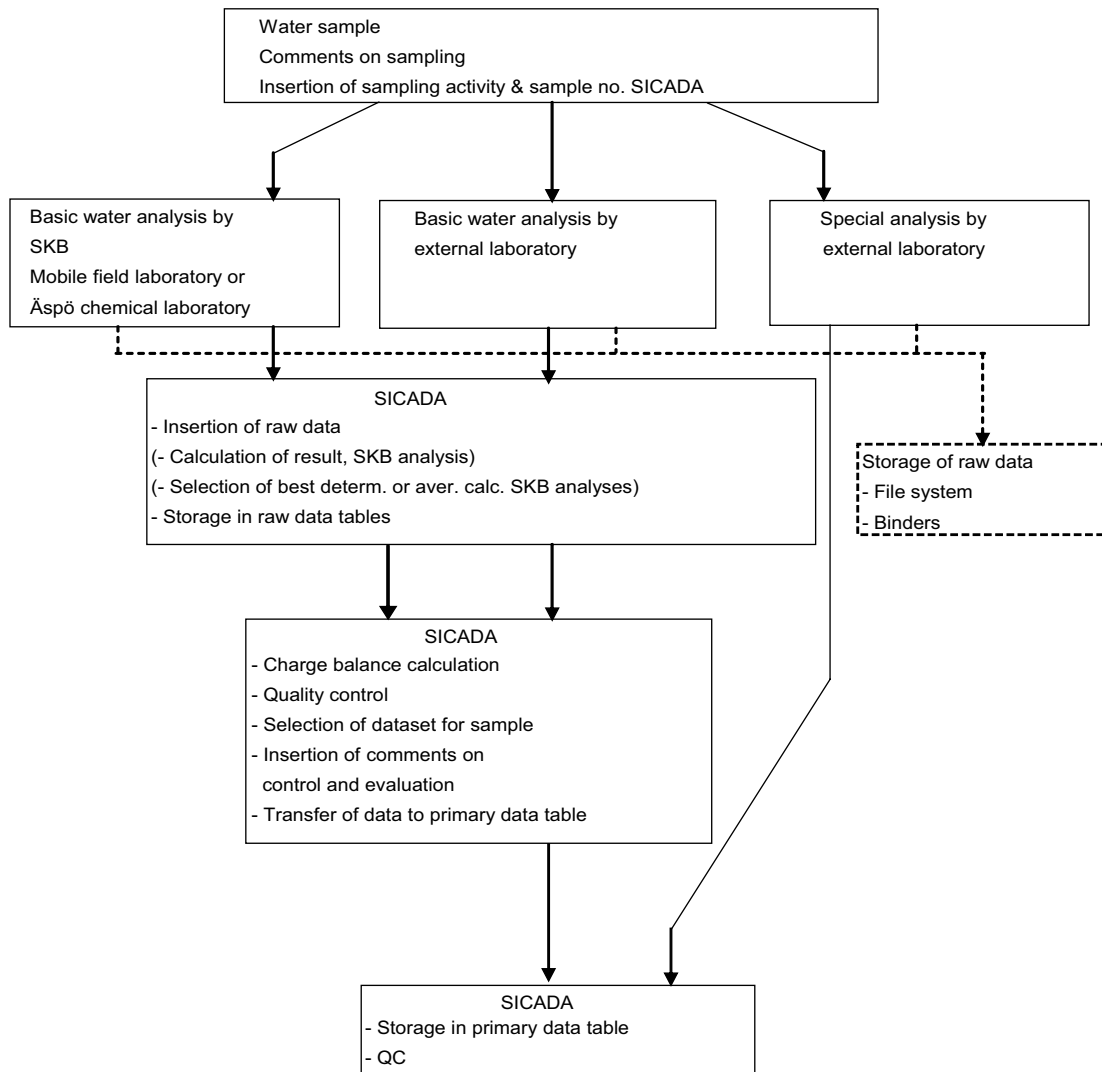

Figure 6-1. Overview of data management for hydrogeochemical data.

6.3 Data from special sampling methods

Special sampling methods include collection of in situ samples (colloid filtration and dissolved gases), enrichment and fractionation of humic and fulvic acids.

Separate sampling activities, methods and sample numbers are defined for data on dissolved gases, colloids, fractions of humic and fulvic acids and $\delta^{13}\text{C}$ and pmC determined on organic constituents. All analytical data are subjected to quality control and stored in the SICADA database.

6.3.1 Colloid filtration

The concentration of the colloid portion caught on each filter is calculated with the assumption that the water volume coming out in the collecting container is equal to the volume going into the system. This is not quite true as up to ten millilitres will be left in cavities in the filter holder package, in the tubing and in valves. A small volume of about 0.01 to 0.06 mL is left in each filter after the filtration and its content of the different elements is included in the analysis. The measurement uncertainty of each colloid concentration is calculated from the “sum” of the measurement uncertainties of the filter analyses and estimated volume error (volume passing through the filters) according to the equation below:

$$U = \sqrt{\left(\frac{1}{V^2} \cdot (\Delta m)^2 + \frac{m^2}{V^4} (\Delta V)^2 \right)}$$

where

U = measurement uncertainty [$\mu\text{g/L}$]

V = water volume through the system [L]

ΔV = estimated volume error, 0.010 L

m = amount on filter [μg]

Δm = measurement uncertainty of the filter analysis, 20% [μg]

The calculated results from the colloid filtration, filters, are stored in SICADA. The results from water samples are directly inserted into the primary data tables in SICADA.

6.3.2 Dissolved gases

The results of the gas analyses are stored in the primary data tables in SICADA. The results for O_2 , N_2 and Ar from laboratory number 2 are recalculated to in order to be comparable to the results from laboratory number 1 that are uncorrected for air contamination. The gas results reported in SICADA correspond to values not corrected for air contamination.

7 Results

Original data from the reported activity are stored in the primary database Sicada. Data are traceable in Sicada by the Activity Plan number (AP PS 400-06-075). Only data in databases are accepted for further interpretation and modelling. The data presented in this report are regarded as copies of the original data. Data in the databases may be revised, if needed. However, such revision of the database will not necessarily result in a revision of this report, although the normal procedure is that major data revisions entail a revision of P-reports. Minor data revisions are normally presented as supplements, available at www.skb.se.

7.1 Chemmac measurements

The data sequences of pH, Eh, electrical conductivity, oxygen and temperature values from the Chemmac measurements in borehole sections 432.0–439.2 m and 499.5–506.7 m are plotted versus time in Appendices 6 and 7 respectively. The measured time series were evaluated in order to obtain a representative value of pH, Eh, electrical conductivity and dissolved oxygen for the borehole as described in Section 6.1. Data were selected from the last part of the measured time series sequences (where the electrodes show stable values), marked with an arrow in the diagrams in the Appendices. The evaluated results from the measurements in the investigated sections are given in Table 7.1 together with the corresponding results from the LIBD measurement.

The redox potentials of the electrodes in borehole Chemmac were stable and consistent in both investigated sections. The recorded potentials were approximately –290 mV in section 432.0–439.2 m and –280 mV in section 499.5–506.7 m. The potentials of the redox electrodes at the surface were diverging and unstable; a possible explanation for this behaviour is variations in the water flow that produce small bubbles of air in the measurement system. In conclusion the Eh data from the borehole electrodes are judged to be most reliable and the data from the surface electrodes were not used in the evaluations for both sections.

The pH electrodes at the ground surface and in the borehole were consistent and stable in both of the sections. At the end of the measurements the readings from the oxygen probe was within the measurement uncertainty.

Table 7-1. Evaluated results from the Chemmac and LIBD measurements in KLX13A.

| Borehole section [m] | Electrical conductivity* [mS/m] | pH (borehole chemmac)** | pH (surface chemmac)** | Eh** [mV] | Dissolved oxygen*** [mg/L] |
|-------------------------------|---------------------------------|-------------------------|------------------------|------------------------|----------------------------|
| 432.0–439.2 | 253 ± 8 | 8.5 ± 0.3 | 8.3 ± 0.2 | –287 ± 14 ^B | 0.01 |
| 432.0–439.2 PVB (LIBD)**** | 256 | – | 8.4 | –234 ^C | < 0.011 |
| 499.5–506.7 | 258 ± 8 | 8.2 ± 0.2 | 8.1 ± 0.2 | –277 ± 10 ^B | 0.01 |

* The electrical conductivity is measured between 0–10,000 mS/m with a total uncertainty of 3%.

** Evaluated result and measurement uncertainty calculated as described in Section 6.1.

*** Measurement interval 0–15 mg/L, resolution and measurement uncertainty ± 0.01 mg/L.

**** See Appendix 8.

^B = only values from borehole Chemmac have been used in the calculation.

^C = redox potential calculated with PHREEQC.

7.2 Water analyses

7.2.1 Basic water analyses

The basic water analyses include the major constituents Na, K, Ca, Mg, S, Sr, SO_4^{2-} , Cl^- , Si and HCO_3^- as well as the minor constituents Fe, Li, Mn, DOC, F, I, HS^- and NH_4^+ . Furthermore, batch measurements of pH (lab-pH) and electrical conductivity (lab-EC) are included. Another important parameter is the flushing water content in each sample. The basic water analysis data and relative charge balance errors are compiled in Appendix 10, Table A10-1. Existing batch measurement values of pH and electrical conductivity are compared with the corresponding on-line Chemmac measurement values in Appendices 6 and 7.

The charge balance errors give an indication of the quality and uncertainty of the analyses of major constituents. The errors did not exceed $\pm 5\%$. Furthermore, the last sample in section 432.0–439.2 m was analysed by a second laboratory. A comparison between results from different laboratories and methods shows that the agreement is acceptable in most cases; in general less than 10% for each analysed constituent.

The flushing water contents in the sample series collected from the borehole sections are presented in Figure 7-1. The flushing water content should not exceed 1% in order for a sample to be considered representative for the groundwater of the sampled fracture zone. This condition was not met for any of the samples collected in sections 432.0–439.2 m or 499.5–506.7 m, with flushing water contents of above 15% and just below 10%, respectively, at the end of the measurement periods. The flushing water content is calculated using the average Uranine concentration in the added flushing water during core drilling.

The concentration levels of sodium, calcium and chloride are presented in Figures 7-2 and 7-3. The concentrations of all major constituents remained more or less constant during the pumping and sampling period in section 432.0–439.2 m and at the end of the investigation sequence in section 499.5–506.7 m.

The iron concentrations determined by ICP-AES (total Fe) and by spectrophotometry (Fe (+II) and Fe-tot) are compared in Figures 7-4 and 7-5. The total iron concentrations determined by ICP agree reasonably well with the results obtained by spectrophotometry. The iron concentrations in section 432.0–439.2 m are close to or below the detection limit in all samples except in sample no. 11611, where the water was sampled from the umbilical hose a couple of hours after pumping. This most likely had an effect on the iron concentration, which is higher than in any of the other samples.

Sulphate analysed by ion chromatography (IC) is compared with sulphate determined as total sulphur by ICP-AES in Figures 7-6 and 7-7. The sulphate concentrations remained more or less constant during both the investigation sequences and the differences between the IC results and the ICP results are within the analytical error.

The chloride concentrations are plotted versus the corresponding electrical conductivity values in Figure 7-8. The plot gives a rough check of the data. As shown, the data from the borehole sections agree well with data obtained by earlier investigations from the Äspö Hard Rock Laboratory.

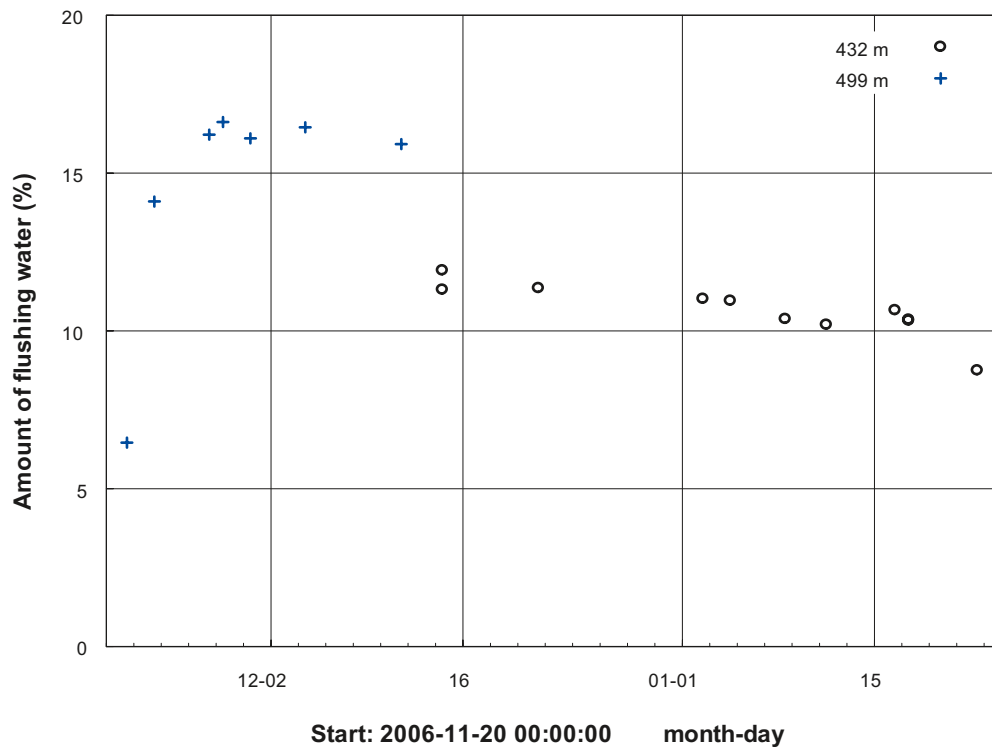

Figure 7-1. Flushing water content in the sample series collected during pumping in borehole sections 432.0–439.2 m and 499.5–506.7 m.

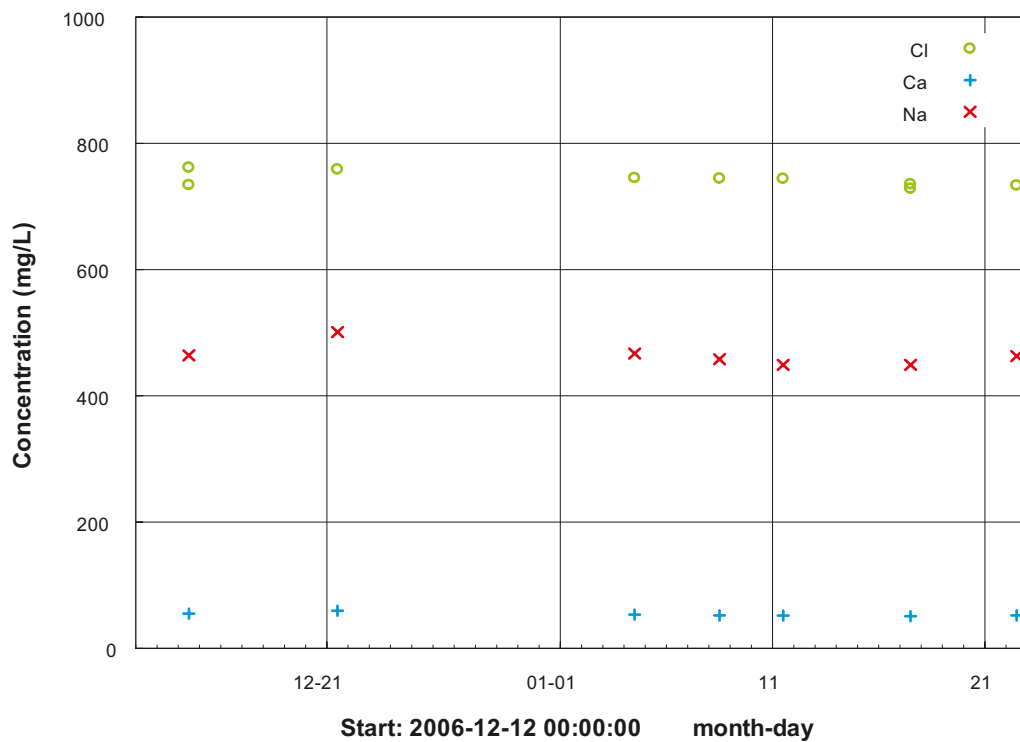

Figure 7-2. Sodium, calcium and chloride concentration trends from sample series at 432.0–439.2 m.

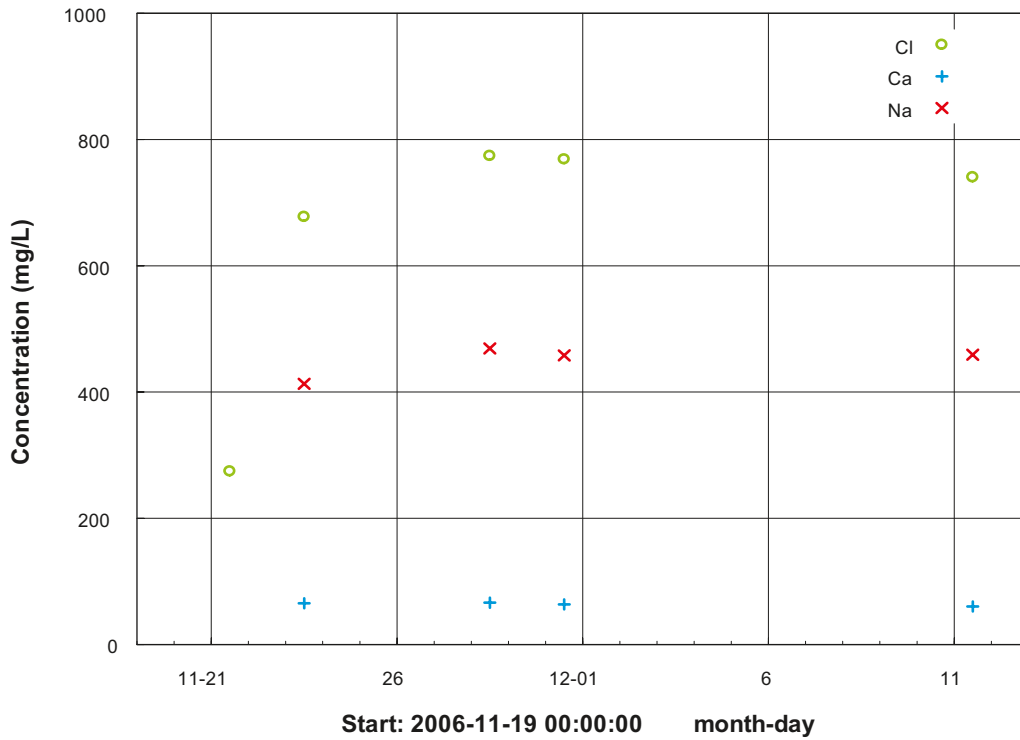

Figure 7-3. Sodium, calcium and chloride concentration trends from sample series at 499.5–506.7 m.

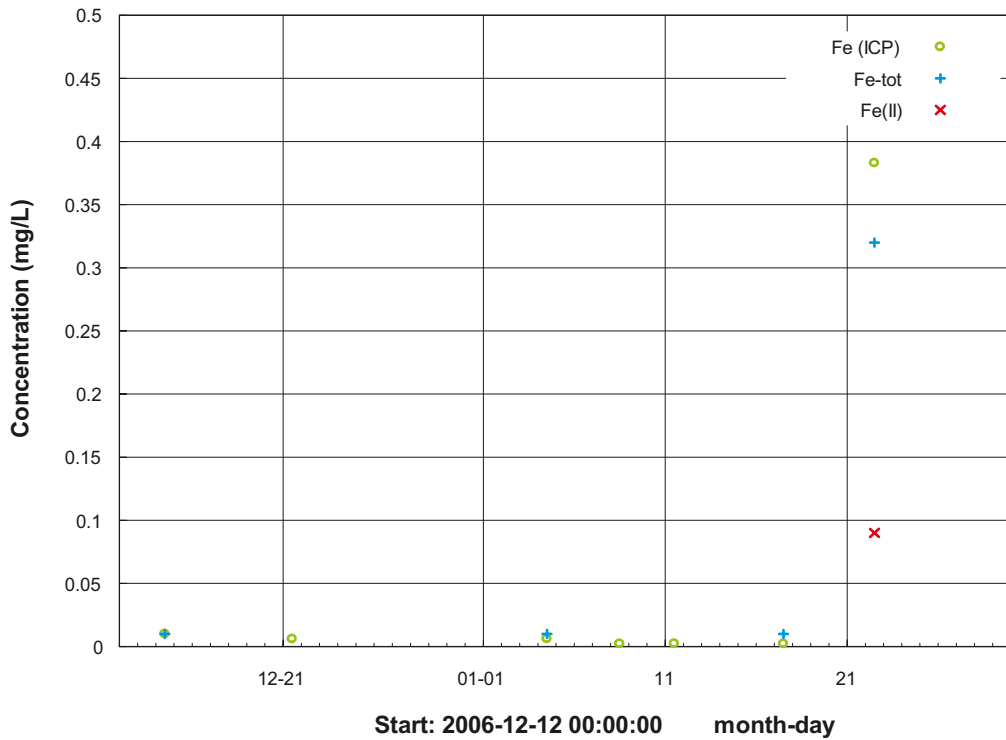

Figure 7-4. Comparison of iron concentrations obtained by ICP-AES and by spectrophotometry, borehole section 432.0–439.2 m. The Fe (II) concentrations were below detection limit in all samples except in sample no. 11611.

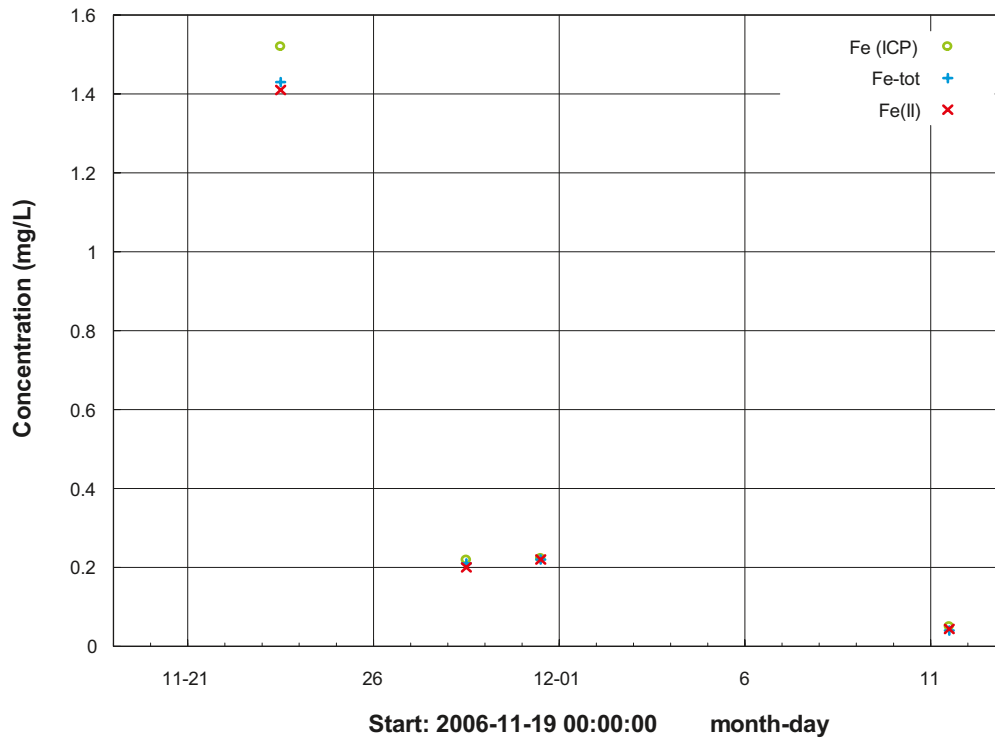

Figure 7-5. Comparison of iron concentrations obtained by ICP-AES and by spectrophotometry, borehole section 499.5–506.7 m.

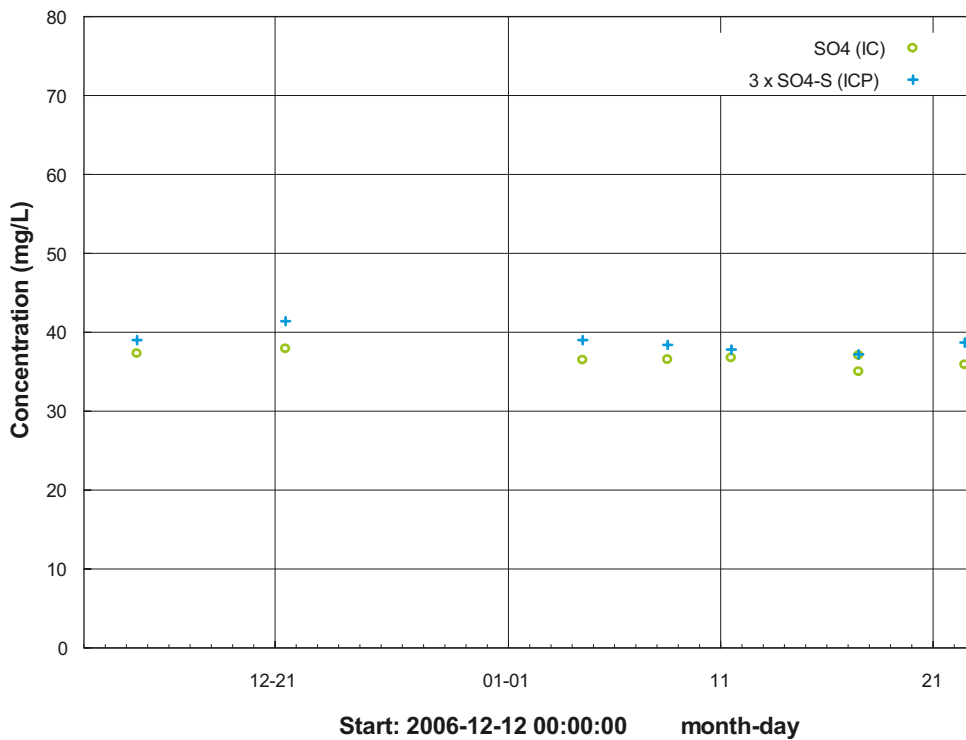

Figure 7-6. Sulphate (SO_4 by IC) to total sulphate calculated from total sulphur ($3 \times SO_4-S$ by ICP) versus date, borehole section 432.0–439.2 m.

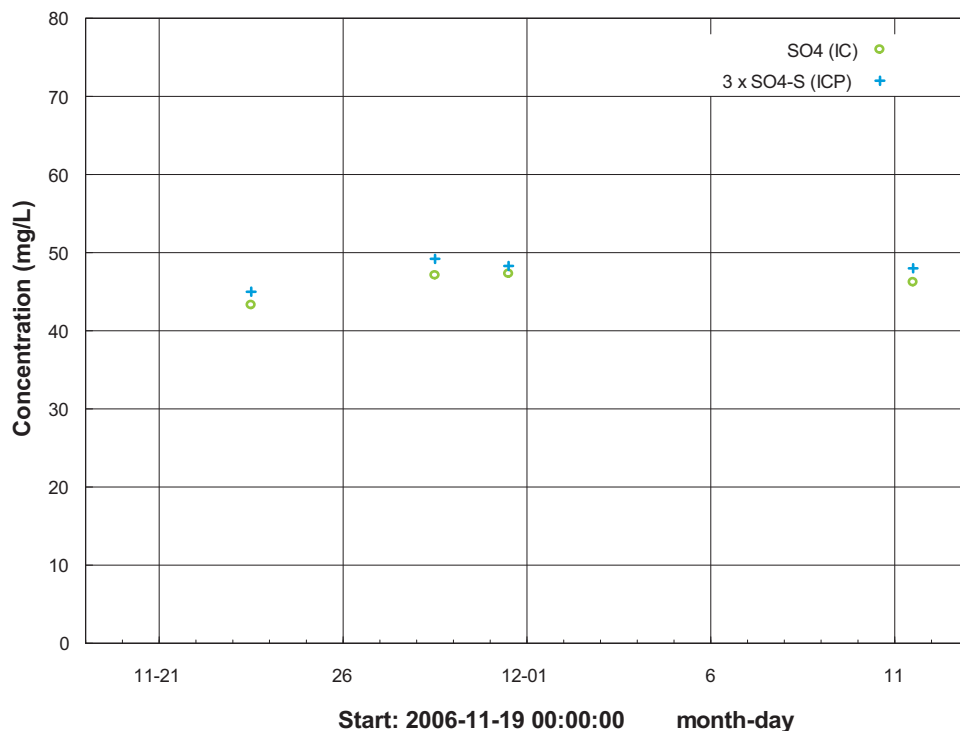

Figure 7-7. Sulphate (SO_4 by IC) to total sulphate calculated from total sulphur ($3 \times SO_4-S$ by ICP) versus date, borehole section 499.5–506.7 m.

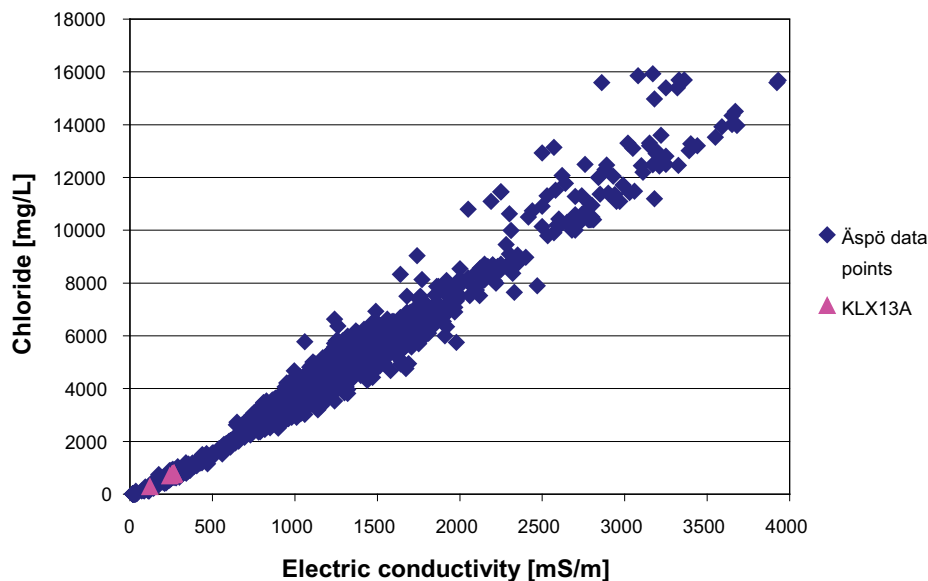

Figure 7-8. Chloride concentration versus electrical conductivity. Data from earlier investigations at the Äspö Hard Rock Laboratory are used to show the linear relationship. The data from KLX13A are consistent with previous investigations.

7.2.2 Trace elements (rare earth metals and others)

The analyses of trace and rare earth metals include U, Th, As, Sc, Cd, Hg, V, Rb, Y, Zr, In, Cs, Ba, La, Hf, Tl, Ce, Pr, Nd, Sm, Eu, Gd, Tb, Dy, Ho, Er, Tm, Yb and Lu. Commonly occurring metals, such as Cu, Zn, Pb and Mo are not included in the analysis programme due to contamination considerations. The trace element data are compiled in Appendix 10, Table A10-2.

7.2.3 Stable and radioactive isotopes

The isotope determinations include the stable isotopes ^2H , $\delta^{18}\text{O}$, $^{10}\text{B}/^{11}\text{B}$, $\delta^{34}\text{S}$, $\delta^{13}\text{C}$ and $^{87}\text{Sr}/^{86}\text{Sr}$ as well as the radioactive isotopes ^3H (TU), ^{14}C (pmC), ^{238}U , ^{234}U , ^{230}Th , ^{226}Ra and ^{222}Rn . Isotope data are compiled in Appendix 10, Tables A10-3 and A10-4. The B-isotope ratio is given as $^{10}\text{B}/^{11}\text{B}$ (the result reported from the consulting laboratory). If one wants to use the notation according to international standard for environmental isotopes, $^{11}\text{B}/^{10}\text{B}$, it is necessary to invert the $^{10}\text{B}/^{11}\text{B}$ value ($1/^{10}\text{B}/^{11}\text{B}$).

The ^3H and $\delta^{18}\text{O}$ results are presented in Figures 7-9 and 7-10. The $\delta^{18}\text{O}$ ratios remained stable during the sampling periods. The ^3H content in both sections was above the detection limit in (0.8 Tritium Units) in all samples except one. It cannot be excluded that a small leakage in the borehole pump has occurred (due to worn o-rings), resulting in contamination from deionised water¹ from the hydraulic pumping system.

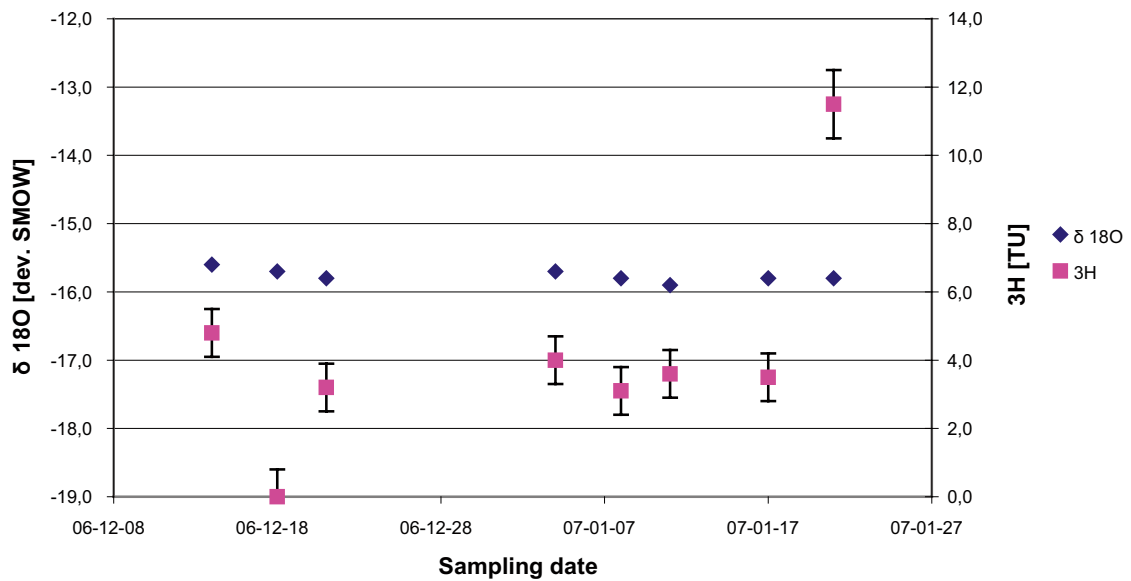

Figure 7-9. ^3H and $\delta^{18}\text{O}$ (‰ SMOW) data versus sampling date, section 432.0–439.2 m.

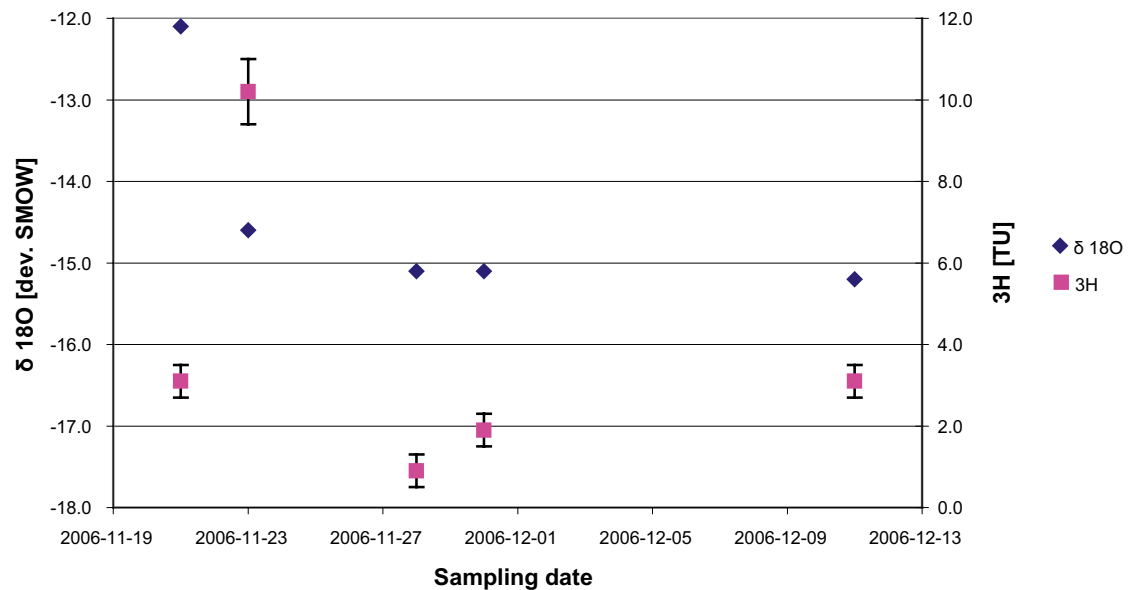

Figure 7-10. ^3H and $\delta^{18}\text{O}$ (‰ SMOW) data versus sampling date, section 499.5–506.7 m.

¹ Deionised water in the hydraulic pumping system might contain tritium, SKB P-07-164.

7.3 Dissolved gas

Sampling for gas was performed in section 432.0–439.2 m at two occasions. Containers with gas samples were sent to two different laboratories (lab 1 and 2). Nitrogen gas was used for purging the samples. The analyses of dissolved gases include argon (Ar), helium (He), nitrogen (N₂), carbon dioxide (CO₂), carbon monoxide (CO) methane (CH₄), oxygen (O₂), hydrogen (H₂), ethane (C₂H₆), ethene (C₂H₄), ethyne (C₂H₂), propane (C₃H₈) and propene (C₃H₆). The gas data are compiled in Appendix 10, Table A10-5.

Total gas content in the groundwater as well as the detected oxygen content is given in Table 7-2. The oxygen content indicates air leakage into the purging system at the consulted laboratory. The effects of air leakage may be corrected for, assuming that the oxygen content is zero, by removing the air effect (nitrogen, oxygen and argon).

The total gas content was similar in both samples from section 432.0–439.2 m, while the concentrations of gas components differed. Probable reasons for the differences in concentrations are errors in analyses, incomplete purging of gas from the containers and contamination of air while purging. Furthermore, the containers were sampled with a time span of about 48 hours. A plot between the vertical depth and the total gas content for several boreholes in the Oskarshamn investigation area suggest gas content > 50 and < 100 ml/liter water. Based on this information the representative gas concentrations in this section are considered as those reported by laboratory 2 (90.27 ml gas/liter).

The gas composition (in vol-%) of the two different samples from section 432.0–439.2 m is compared in Figures 7-11 and 7-12.

Table 7-2. Total content of dissolved gas.

| | Section 432.0–439.2 m Laboratory 1 | Section 432.0–439.2 m Laboratory 2 |
|--------------------------|--|--|
| Total gas content [mL/L] | 106 | 90.27 |
| Oxygen content [mL/L] | 0.047 | 0.5 |

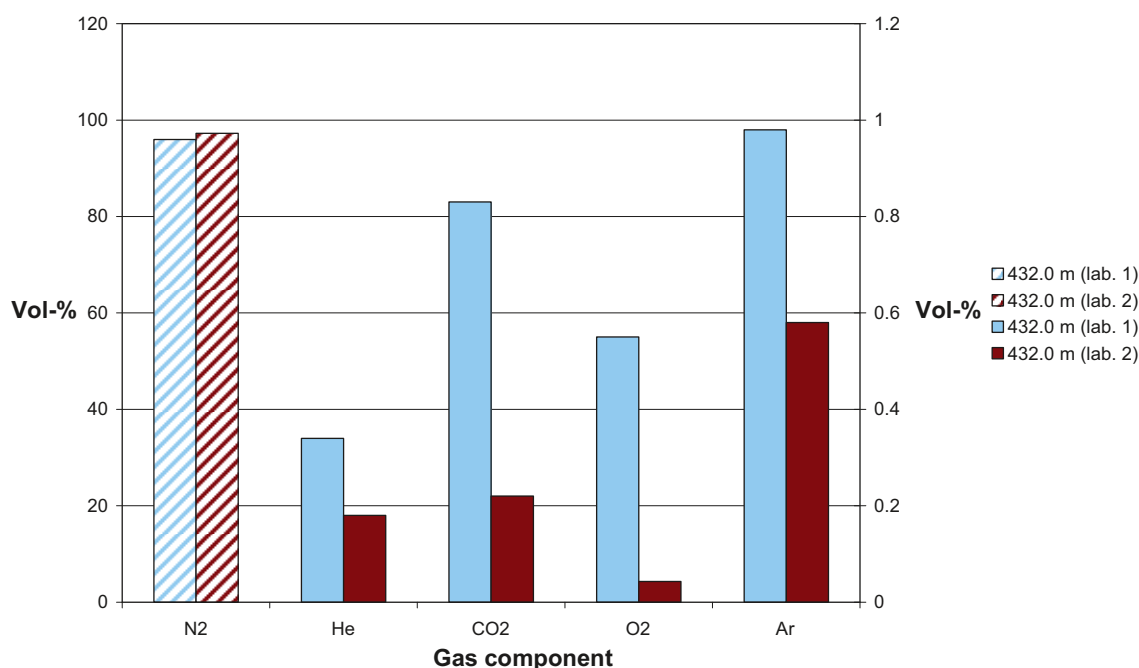

Figure 7-11. Gas components of high concentrations (N₂, He, CO₂, O₂ and Ar) in samples collected in KLX13A using the in situ sampling equipment. Striped and non-striped bars refer to the scales on left and right axis, respectively.

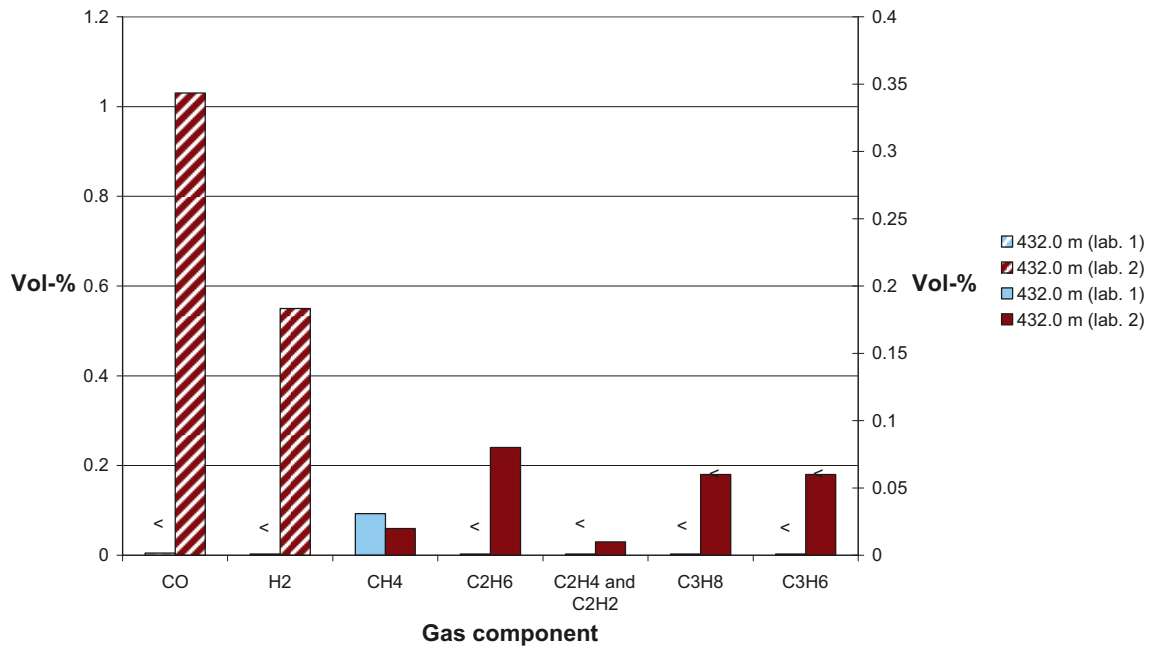

Figure 7-12. Gas components of low concentrations (CH_4 , CO , H_2 , C_2H_6 , sum of C_2H_4 and C_2H_2 , C_3H_8 and C_3H_6) in samples collected in KLX13A using the in situ sampling equipment. Striped and non-striped bars refer to the scales on left and right axis, respectively.

7.4 Colloids

The presence of colloids in section 432.0–439.2 m was investigated using two methods; 1) filtration through a series of connected filters in an argon atmosphere and 2) Laser-Induced Breakdown Detection, LIBD, Appendix 8.

The results from the colloid filtration and the LIBD determinations in section 432.0–439.2 m are presented in Table 7-3. The results from the filtration runs are corrected by subtracting the dissolved elements (indicated by the sodium content) in the remaining filter water. Furthermore, the analysed elements are re-calculated to amounts of their most probable mineral phases (illite, calcite, iron hydroxide and manganese hydroxide).

The table illustrates the difficulties associated with colloid determinations. Generally, it is expected that the measured colloid concentrations turn out higher than the natural amount of background colloids in the groundwater as additional colloids are easily generated by artefacts. The sources may be:

- Oxygen intrusion and formation of iron hydroxide.
- Decrease of pressure and precipitation of calcite.
- The sampling process or the equipment.

The LIBD and filtration results are consistent and suggest a colloid concentration of 2–5 and 12 $\mu\text{g/L}$, respectively. Furthermore, a second fraction with diameters of 1,100–1,400 nm and mass concentrations 680–1,380 $\mu\text{g/L}$ were present in the LIBD experiment.

Table 7-3. Colloid concentrations measured in the groundwater sample from section 432.0–439.2 m. Comparison of results obtained by filtration and by LIBD technique.

| Filtration through series of connected filters | | | | | | LIBD | | |
|--|----------------------------|--|------|----|-----------------------|---------------------------|------------------------------|-------------------|
| Idcode/ secup/ filter pore size (µm) | Filtrate volume (mL) | Element content on each filter per litre of water (µg/L) | | | Mineral phases (µg/L) | | Idcode/ secup/ run no. | Content (µg/L) |
| | | Al | Fe | Mn | Total/ filter* | Sum**/ one/two filters | | |
| KLX13A/ 432.0/0.2 | 307 | 0.320 | 2.12 | 0 | 6.02 | 12.3 | KLX13A/ 432/1 | 2–5 |
| KLX13A/ 432.0/0.05 | 307 | 0.119 | 2.90 | 0 | 6.28 | | KLX13A/ 432/2 | 2 |

* Total content on each filter. Aluminium is calculated as 2.3 Al in K-Mg-illite (383.9 g/mol), iron is calculated as Fe(OH)₃ (106.8 g/mol) and manganese is calculated as Mn(OH)₂ (88.9 g/mol). The sulphur content on the filters was below detection limit and the silicon content was also below or close to the detection limit.

** Sum of content (mineral phases) on filters 0.2 µm and 0.05 µm filters.

7.4.1 Inorganic colloids – colloid filtration

The results from the colloid filtration performed in section 432.0–439.2 m are presented in Figures 7-13 to 7-18.

The bars in the diagrams represent amounts (µg) of aluminium, iron, silicon, manganese, sulphur and calcium entering the filter package, collected on each filter and present in the collecting container. The amounts are calculated assuming that the water volume coming out in the collecting container is equal to the volume going into the system. This is not quite the case as up to ten millilitres will be left in cavities in the filter holder package, in the tubing and in valves. Further, a small volume of about 0.01 to 0.06 mL is left in each filter after the filtration and the salt content of this volume is included in the analysis. The presented input amounts, in the diagrams below, represent the sample taken on-line at the surface just before opening the PVB containers for sampling.

The concentrations in blank samples (rinsing water), PVB containers, collecting container and pumped groundwater are given in Table 7-4. The remaining water in the PVB containers after filtration was possibly contaminated by aluminium, iron and manganese. The evaluation is complicated for iron and aluminium since precipitation reactions and/or contamination has to be considered.

The iron concentration in the outgoing water is much lower than the amount detected in the collecting container after passing the filters despite that almost nothing is detected on the filters. This could be caused by precipitation of iron after passing the filtering system, possibly in the collecting container. Or, precipitation of iron occurs in the PVB container which reduces the actual input concentration.

On the other hand, the amount of aluminium detected on the filters and in the outgoing water is higher than in the incoming water. This indicates that the outgoing water is contaminated with aluminium after passing the filtering system, maybe in the collecting container. Or, the water is contaminated by aluminium from the PVB containers which means that the actual input concentration is higher than what is indicated by the water sample analysed as input concentration. The aluminium discrepancy may also be due to analytical uncertainty, since the concentrations are very low.

When performing the leakage test, blank filters were sent for analysis. The results showed that the contribution of aluminium, iron, sulphur and manganese from the leakage test, the deionised water and the filters were insignificant. The amount of silicon incorporated on the filters was large during the leakage test. However, from the borehole sample filtration the amount of incorporated silicon was very low, below or just above the reporting limit although the input amount

of silicon from the borehole water was 40 times higher than in the leakage test. As the method for digestion of the filters used by the analysing laboratory was too weak for silicon, the amount of silicon may be underestimated.

Filter analyses of calcium and sulphur show values below the reporting limits. For manganese, the values are below or just above the reporting limit.

The following may be concluded from the colloid filtration results:

- The amounts present as colloidal iron and aluminium in sections 432.0–439.2 m are somewhat difficult to evaluate since the output amount plus the amount collected on filters does not balance the input amount. The reasons for this are contamination and/or precipitation in the PVB containers or in the collecting container.
- Low amounts of the investigated metals are detected on the filters, except for aluminium and iron. For S and Ca the values are below the detection limit for all filters.

Table 7-4. Concentrations in blank water, remaining water in PVB container, collected output water from filter system and pumped water that has not passed the filter system.

| Section m | Sample origin | Al µg/L | Fe mg/L | Si mg/L | Mn µg/L | Ca mg/L | S mg/L | |
|-------------|---------------------------------|---------|---------|---------|---------|---------|--------|------|
| 432.0–439.2 | Blank, deionised water | 0.276 | 0.0012 | < 0.03 | < 0.03 | < 0.1 | < 0.2 | |
| | Blank, leakage test | 3.58 | 0.0849 | 0.395 | 15.7 | 0.258 | < 0.3 | |
| | Pumped water (alt. input conc.) | 9.75 | 0.286 | 6.51 | 38.0 | 51.1 | 12.3 | |
| | Rest volume PVB (input conc.) | | 9,810 | 112 | 31.5 | 2,330 | 64.2 | 13.9 |
| | | | 7,700 | 17 | 21.8 | 356 | 61.2 | 12.7 |
| | Collecting container | 4.21 | 0.129 | 6.51 | 33.8 | 50.7 | 12.5 | |

Blank, leakage test = remaining water in the PVB container after filtration of blank sample/de-ionised water.

Pumped water = sample collected at the surface and not in situ in the borehole section.

Rest volume PVB = remaining water in the PVB container after filtration of sample.

Collecting container = water that has passed the filter system.

Results of colloid filtering experiment, using water sample from section 432.0–439.2 m

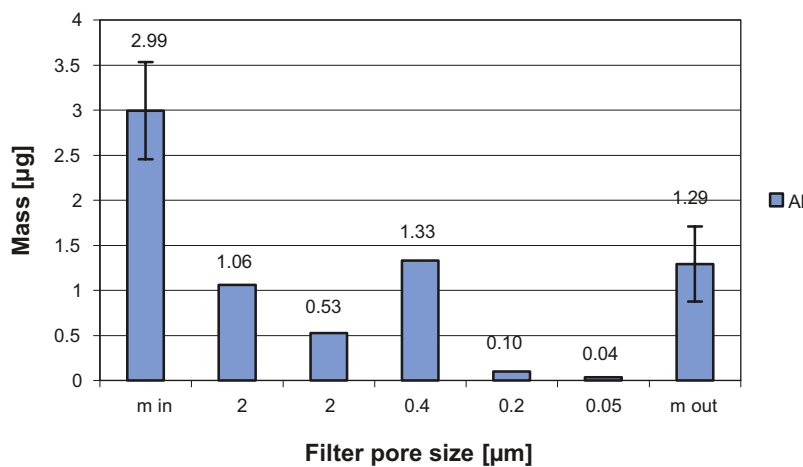

Figure 7-13 Amount of aluminium entering the filter system (*m in*), in the filters and in the collecting container (*m out*).

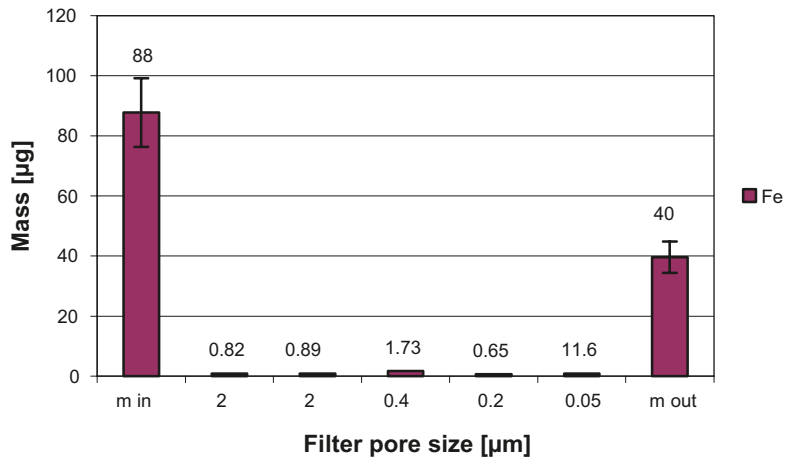

Figure 7-14. Amount of iron entering the filter system (m in), in the filters and in the collecting container (m out).

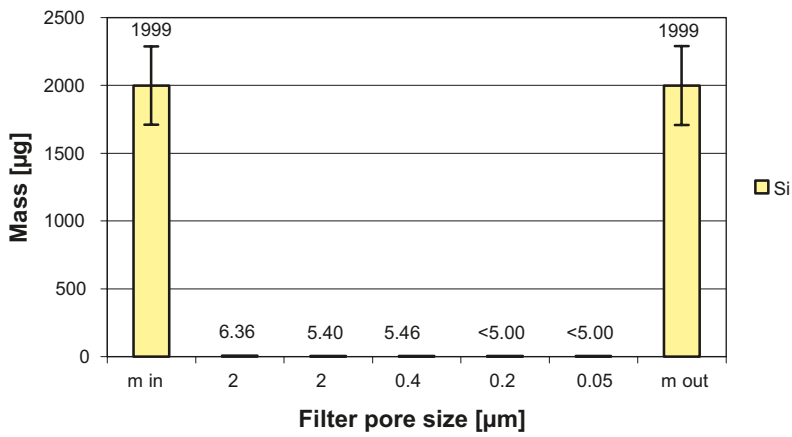

Figure 7-15. Amount of silicon entering the filter system (m in), in the filters and in the collecting container (m out).

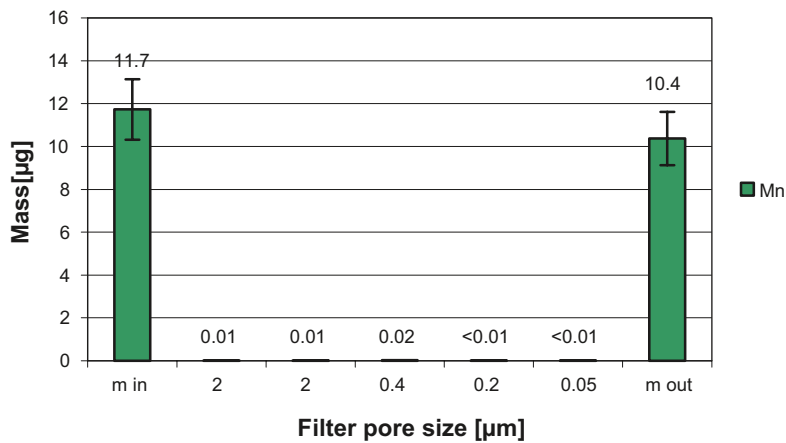

Figure 7-16. Amount of manganese entering the filter system (m in), in the filters and in the collecting container (m out).

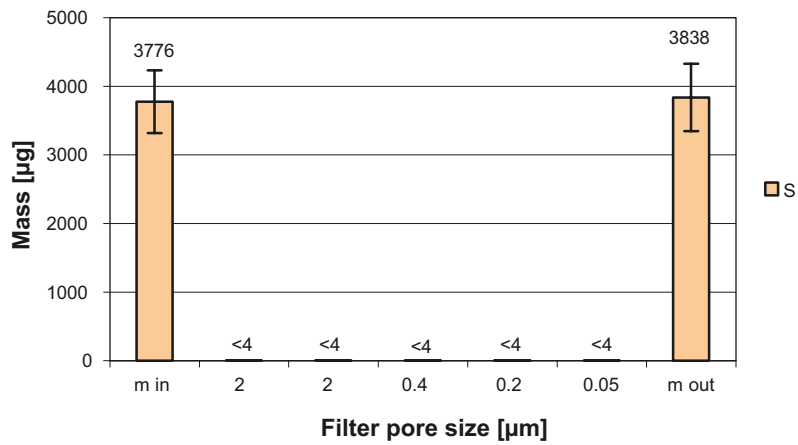

Figure 7-17. Amount of sulphur entering the filter system (m in), in the filters and in the collecting container (m out).

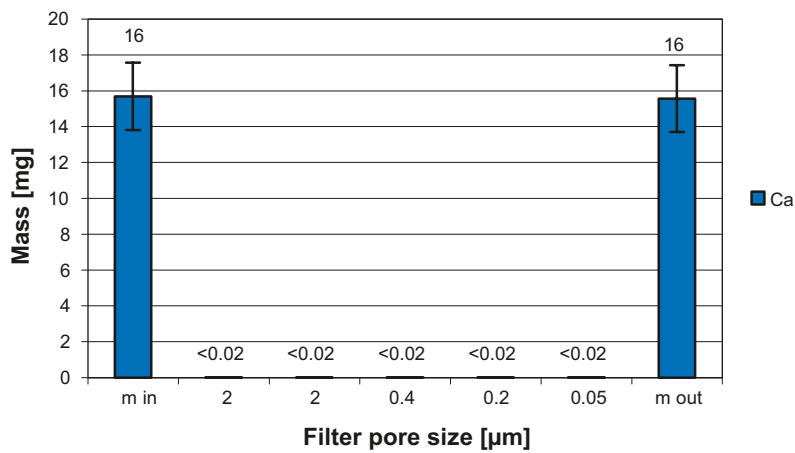

Figure 7-18. Amount of calcium entering the filter system (m in), in the filters and in the collecting container (m out).

8 Summary

The *Complete chemical characterisation* programme in KLX13A was reduced due to high content of flushing water.

The main conclusions from the available experimental results are:

- An upper limit for the allowed flushing water content in a representative water sample is set to 1%. This condition was not met in either section 432.0–439.2 m (9%) or in section 499.5–506.7 m (16%).
- The salinity and ^3H concentrations in the two borehole sections suggest an influence of surface water; however, the values for $\delta^{18}\text{O}$, pmC and the salinity indicate glacial melt water. This is not supported by the high ^3H concentrations and would imply a possible contamination from ^3H containing deionised water in the hydraulic pumping system.
- The drawdown during pumping was low, at most 0.4 m in section 499.5–506.7 m. However, the stable concentrations of the major constituents during the pumping/sampling period indicates that no mixing occurred with water from other fracture systems with different water compositions.
- The quality of the water analyses is generally high, based on comparison between results from different laboratories, methods and acceptable charge balance errors. The relative errors are all within $\pm 5\%$.
- The redox potential measurements from the borehole Chemmac in sections 432.0–439.2 m and 499.5–506.7 m appear to be of good quality. The three electrodes (gold, glassy carbon and platinum) in the borehole reached stable and consistent values (-290 and -280 mV respectively). It is a reasonable result that the redox potentials in both of the sections ended at more or less the same value since the borehole sections are close to each other and the groundwater conditions are similar. The redox electrodes on the ground surface gave unstable and diverging values, probably due to variations in the water flow.
- The LIBD and colloid filtration results suggest a colloid concentration of 2–12 $\mu\text{g/L}$. However, additional colloids are easily generated by artefacts and the natural concentration in the groundwater may be lower.

References

- /1/ **SKB, 2001.** Site investigations. Investigation methods and general execution programme. SKB TR-01-29, Svensk Kärnbränslehantering AB.
- /2/ **Pedersen K, 2008.**
Oskarshamn site investigation. Microorganisms in groundwater from boreholes KLX13A and KLX17A: numbers, viability and metabolic diversity. Results from three sections: 432.0–439.2 m in KLX13A and 416.0–437.5 m and 642.0–701.1 m in KLX17A. SKB P-08-08 (In press), Svensk Kärnbränslehantering AB.
- /3/ **Ask H, Morosini M, Samuelsson L-E, Tiberg L, 2007.**
Drilling of cored borehole KLX13A. Oskarshamn site investigation. SKB P-07-195. Svensk Kärnbränslehantering AB.
- /4/ **Lindquist A, 2006.**
Oskarshamn site investigation. Hydrochemical logging in KLX13A. SKB P-06-280, Svensk Kärnbränslehantering AB.
- /5/ **Gustafsson J, Gustafsson C, 2006.**
Oskarshamn site investigation. RAMAC, BIPS and deviation logging in boreholes KLX13A, HLX30 and HLX33. SKB P-05-240, Svensk Kärnbränslehantering AB.
- /6/ **Nielsen U T, Ringgaard J, 2005.**
Oskarshamn site investigation. Geophysical borehole logging in boreholes KLX13A, HLX30, HLX31 and HLX33. SKB P-05-270, Svensk Kärnbränslehantering AB.
- /7/ **Sokolnicki M, Pöllänen J, 2006.**
Oskarshamn site investigation. Difference flow logging of borehole KLX13A. Subarea Laxemar. SKB P-05-267, Svensk Kärnbränslehantering AB.

Technical data

Borehole KLX13A

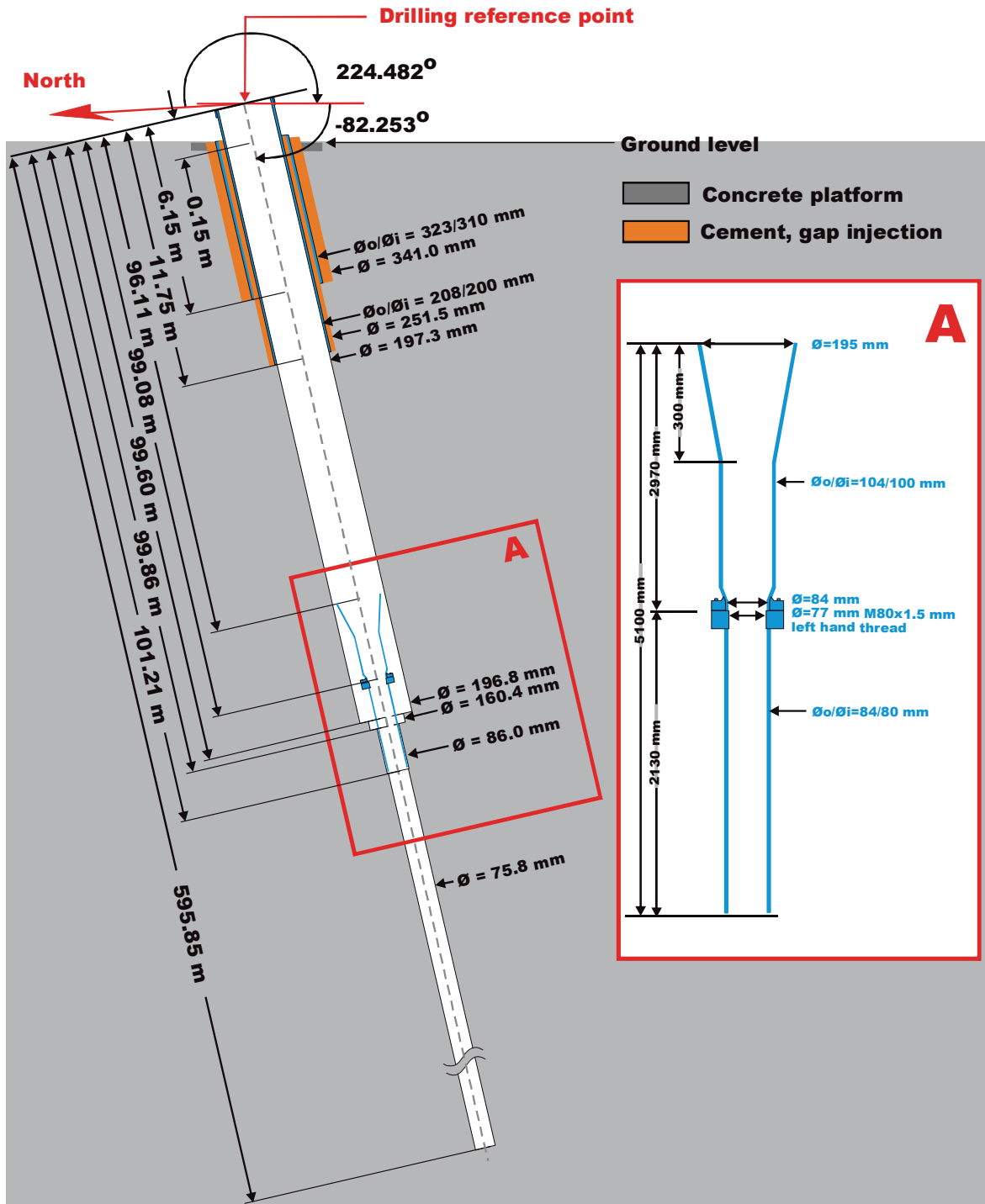

Drilling reference point

Northing: 6367547.144 (m), RT90 2,5 gon V 0:-15

Easting: 1546787.363 (m), RT90 2,5 gon V 0:-15

Elevation: 24.153 (m), RHB 70

Drilling period

Drilling start date: 2006-05-19

Drilling stop date: 2006-08-16

Selected results from differential flow logging in KLX13A

Laxemar, borehole KLX13A
 Flow rate, caliper and single point resistance

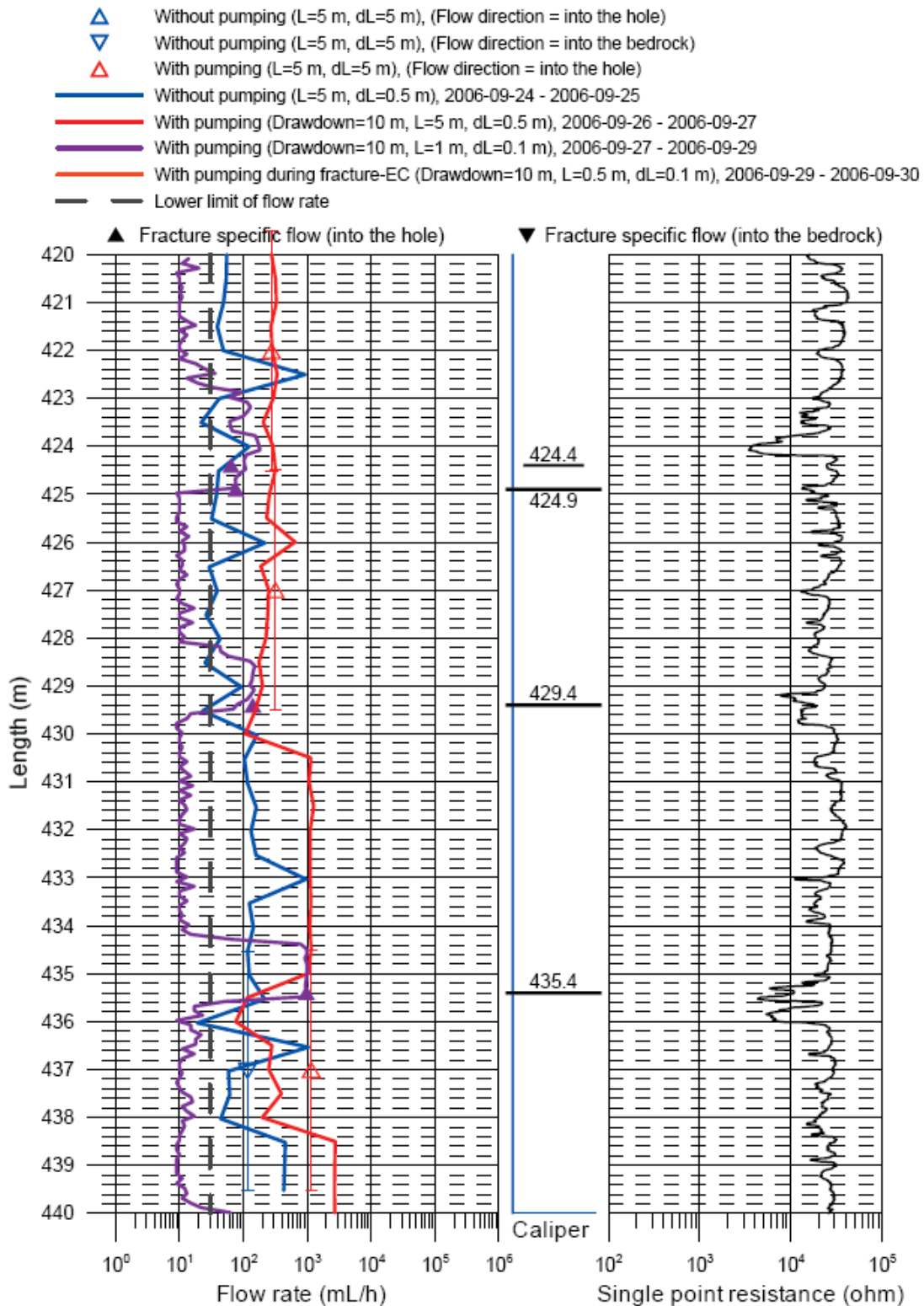

Figure A2-1. Borehole KLX13A: Differential flow measurements from 420-440 m including the water bearing fracture zones at 433 m and 436 m /6/.

Selected results from differential flow logging in KLX13A

Laxemar, borehole KLX13A

Flow rate, caliper and single point resistance

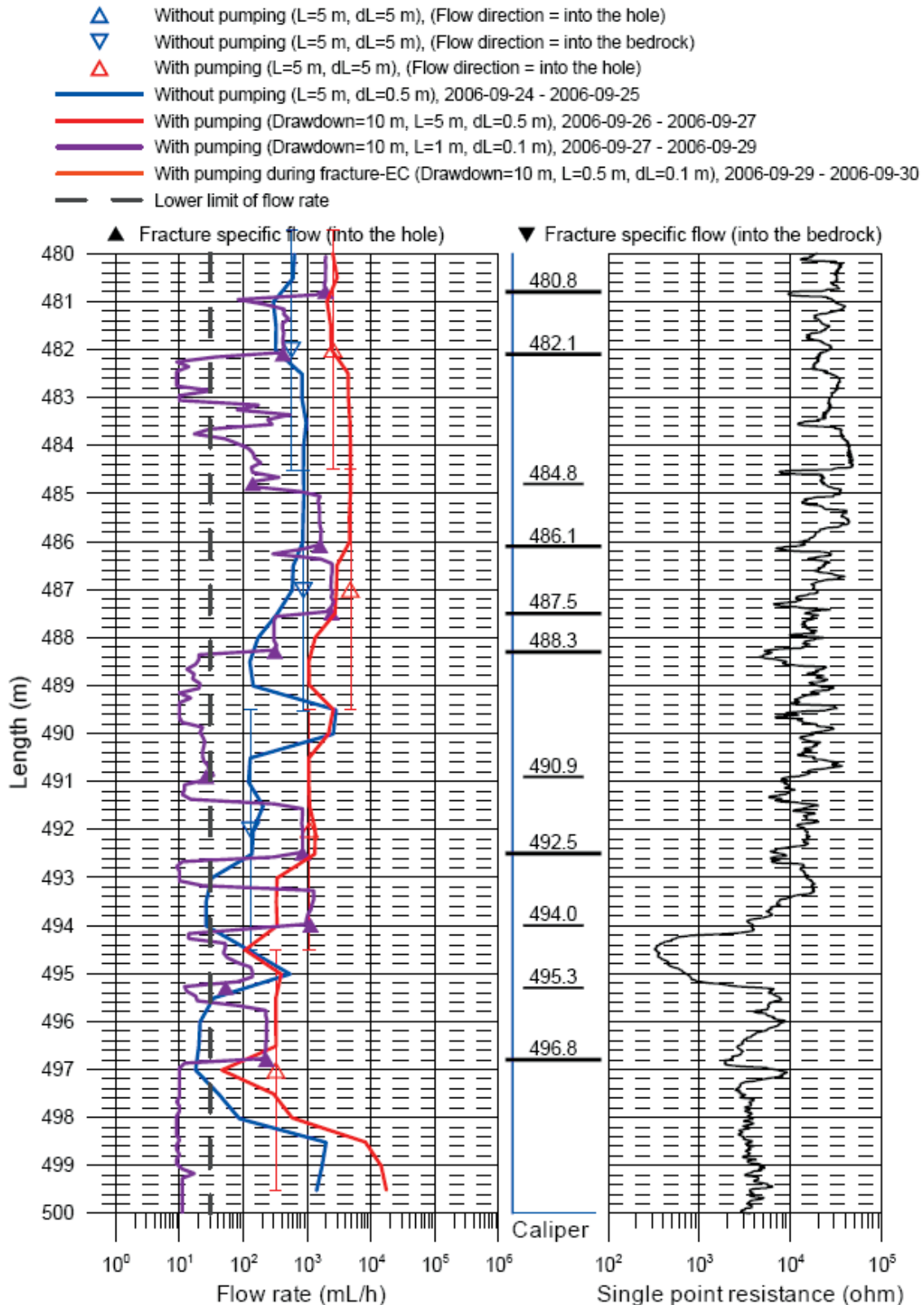

Figure A2-2a. Borehole KLX13A: Differential flow measurements from 480-500 m including the water bearing fracture zones at approximately 503 m /6/.

Selected results from differential flow logging in KLX13A

Laxemar, borehole KLX13A
Flow rate, caliper and single point resistance

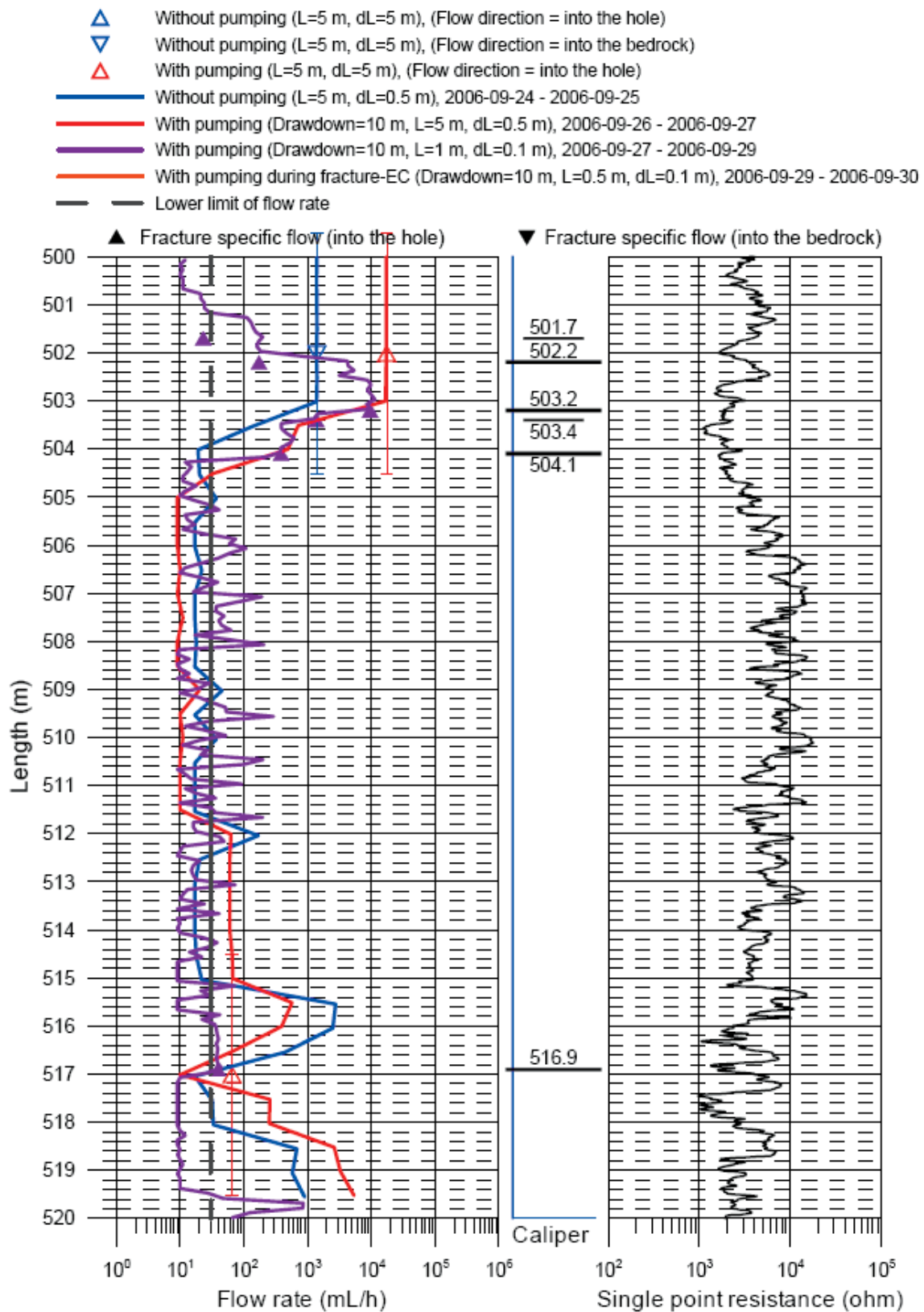

Figure A2-2b. Borehole KLX13A: Differential flow measurements from 500-520 m including the water bearing fracture zone at approximately 503 m /6/.

Selected images from BIPS logging in KLX13A

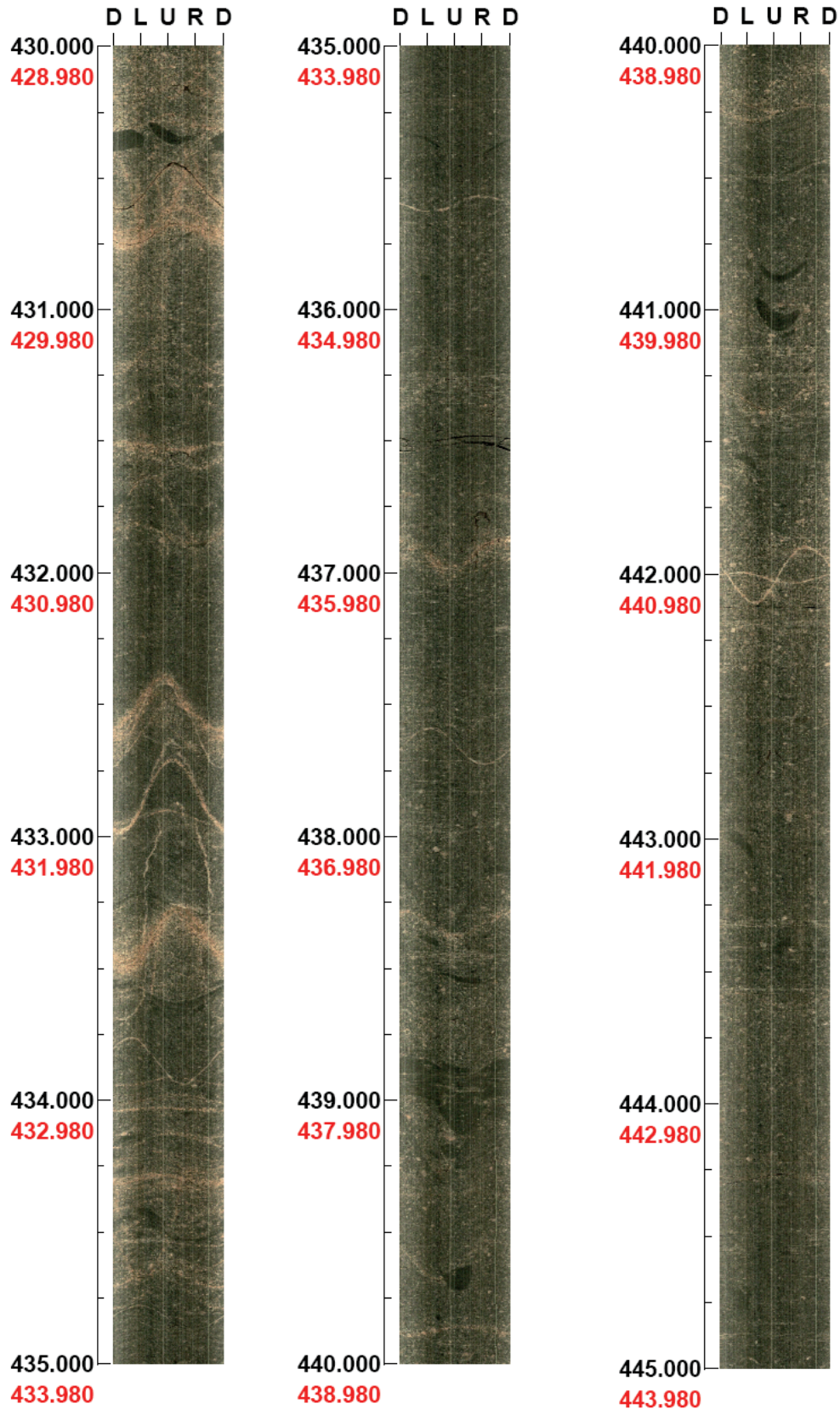

Figure A3-1. Borehole KLX13A: selected BIPS logging image from 429.0 to 444.0 m including the water bearing fractures at 433 m and 436 m. The non-adjusted length is marked with black and the adjusted true length is marked with red /4/.

Selected images from BIPS logging in KLX13A

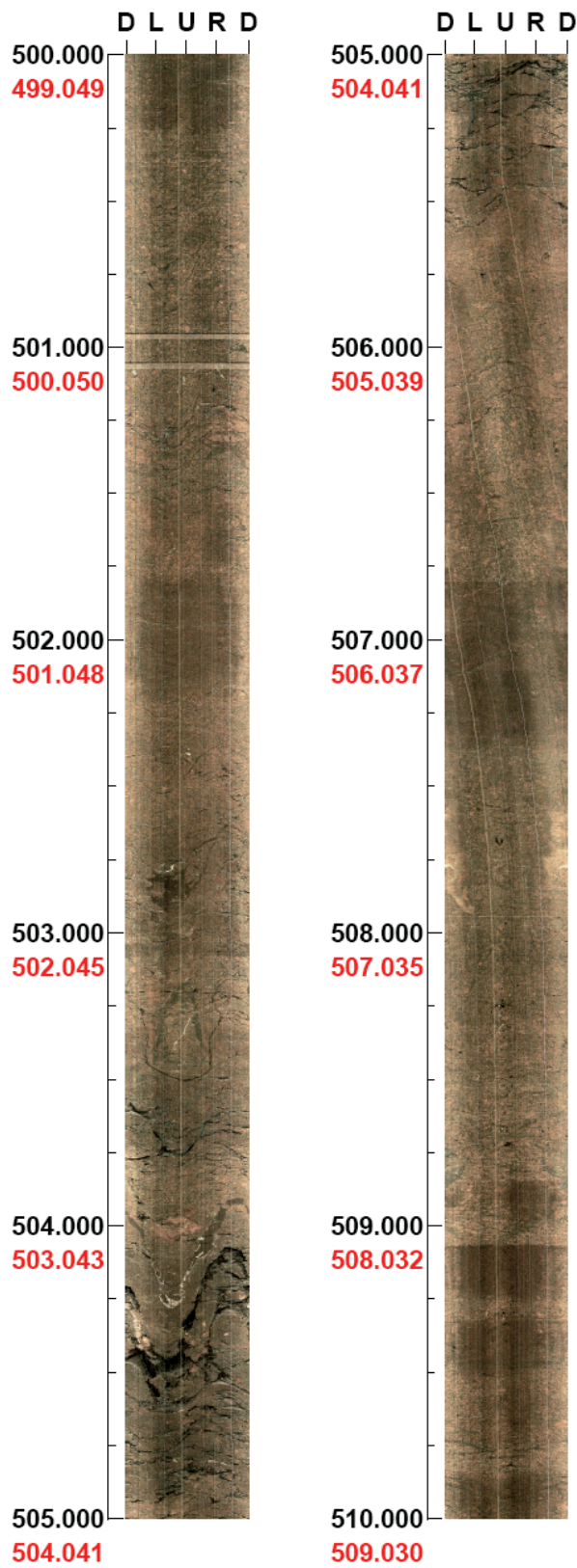

Figure A3-2. Borehole KLX13A: selected BIPS logging image from 499.5 to 509.0 m including the water bearing fracture at 503 m. The non-adjusted length is marked with black and the adjusted true length is marked with red /4/

Measurement information, KLX13A

Section 432.0-439.2m

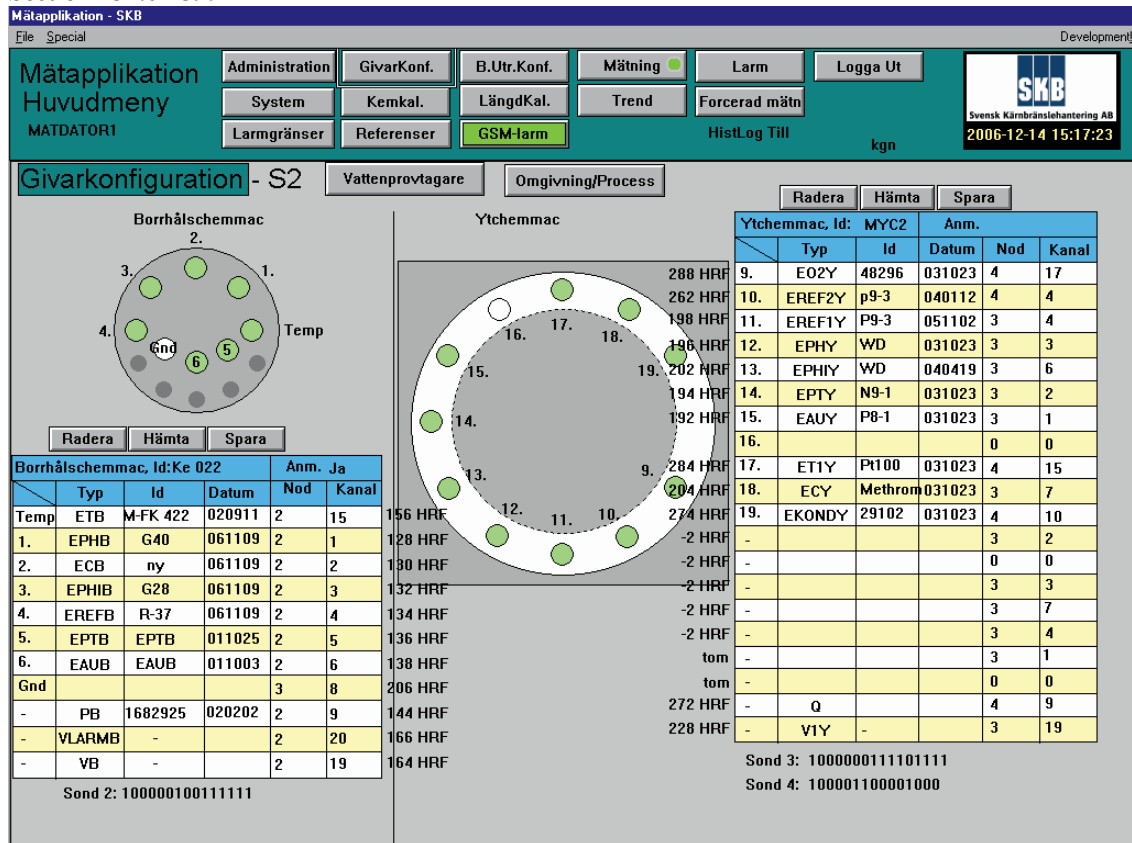

Figure A4-1. Electrode configuration, section 432.0-439.2 m.

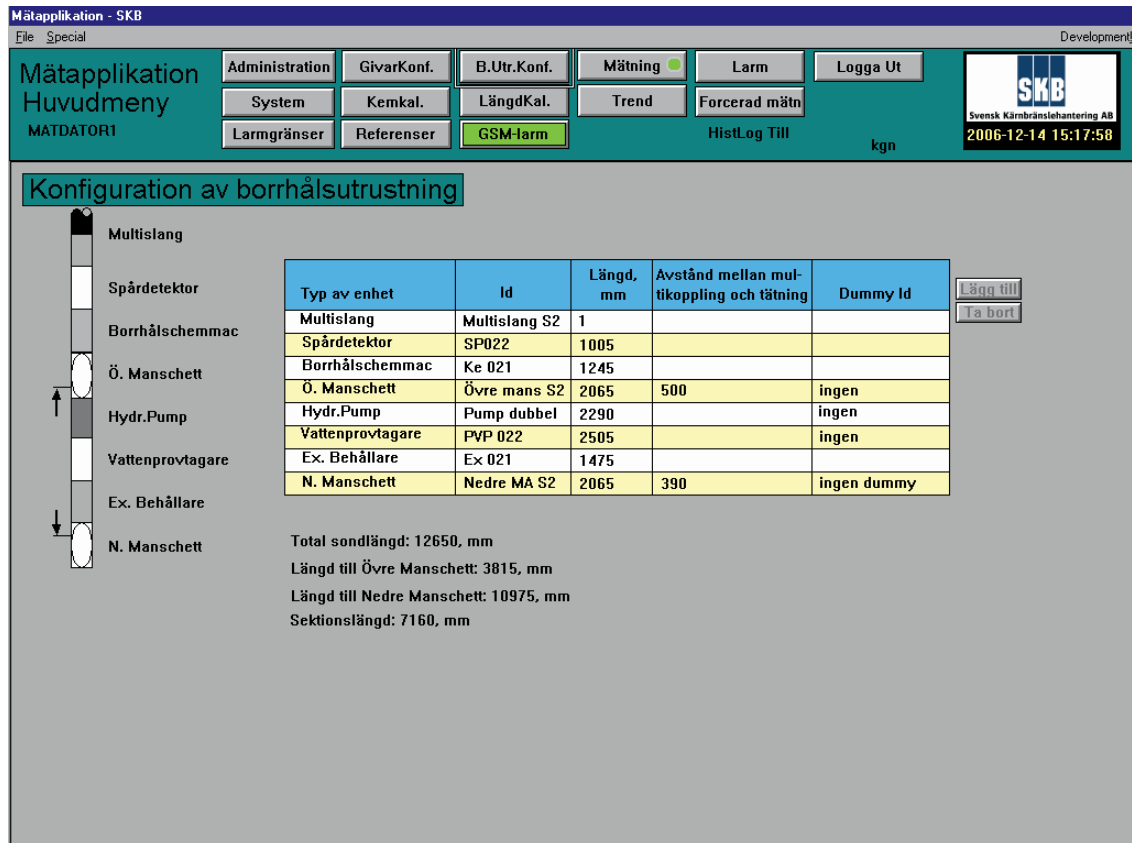

Figure A4-2. Configuration of downhole equipment, section 432.0-439.2 m.

Measurement information, KLX13A

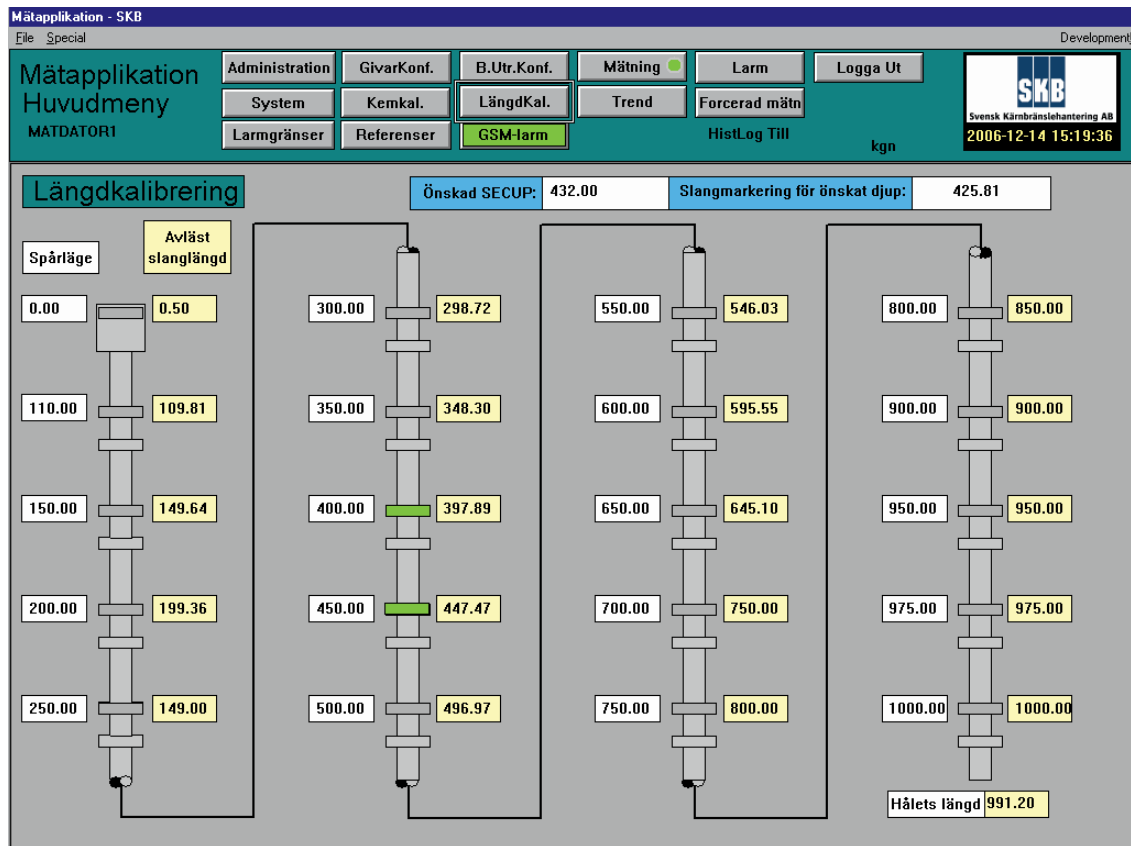

Figure A4-3. Length calibration, section 432.0-439.2 m.

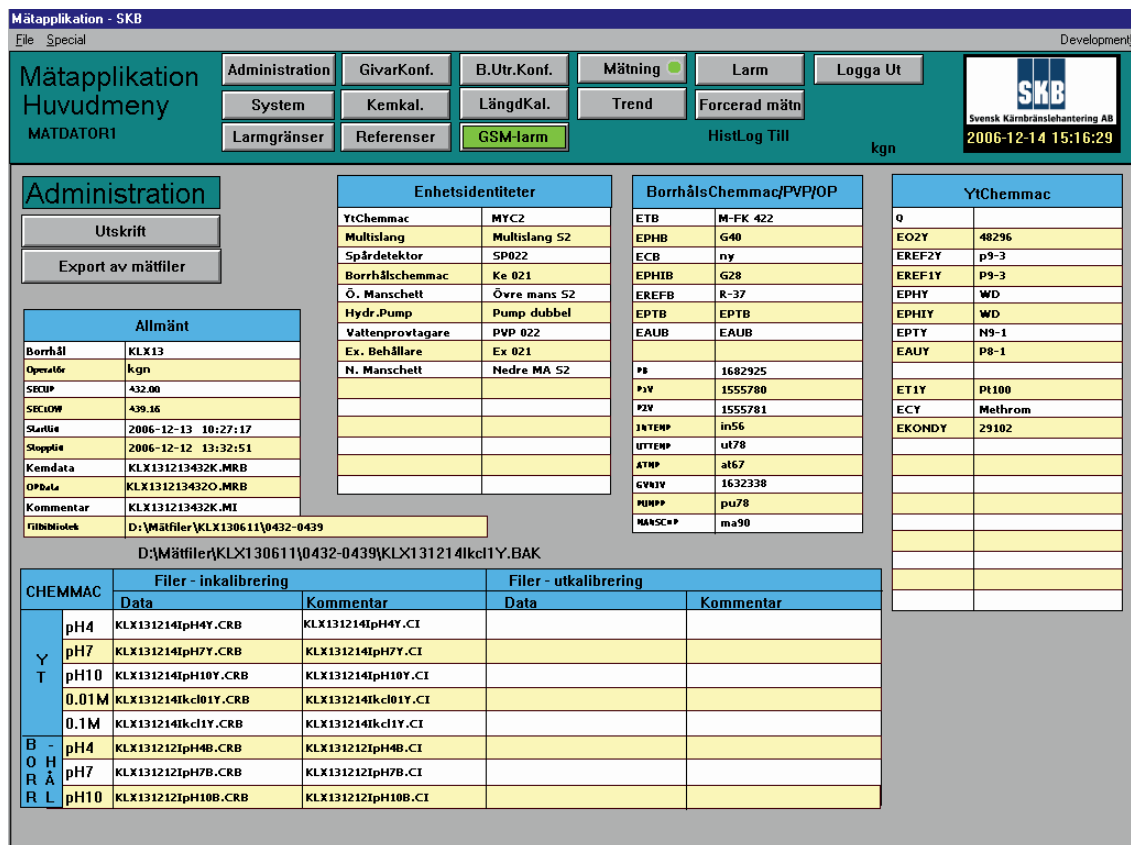

Figure A4-4. Administration, section 432.0-439.2 m.

Measurement information, KLX13A

Section 499.5-506.7m

Mätapplikation - SKB
File Special Development

Mätapplikation Huvudmeny MATDATOR1

Administration GivarKonf. B.Utr.Konf. Mätning Alarm Logga Ut
System Kemkal. LängdKal. Trend Forcerad mätn
Larmgränser Referenser GSM-larm HistLog Till kgn

Givarkonfiguration - S2 Vattenprovtagare Omgivning/Process

Radera Hämta Spara

| Borrhålschemmac, Id: Ke 022 | | Anm. Ja | | | |
|-----------------------------|--------|---------|--------|-----|-------|
| Temp | Typ | Id | Datum | Nod | Kanal |
| 1. | EPHB | G40 | 061109 | 2 | 1 |
| 2. | ECB | ny | 061109 | 2 | 2 |
| 3. | EPHB | G28 | 061109 | 2 | 3 |
| 4. | EREFB | R-37 | 061109 | 2 | 4 |
| 5. | EPTB | EPTB | 011025 | 2 | 5 |
| 6. | EAUB | EAUB | 011003 | 2 | 6 |
| Gnd | | | | 3 | 8 |
| - | PB | 1682925 | 020202 | 2 | 9 |
| - | VLARMB | - | - | 2 | 20 |
| - | VB | - | - | 2 | 19 |

Sond 2: 100000101111111

| Ytchemmac, Id: MYC2 | | Anm. | | | |
|---------------------|--------|---------|--------|-----|-------|
| Temp | Typ | Id | Datum | Nod | Kanal |
| 9. | E02Y | 48296 | 031023 | 4 | 17 |
| 10. | EREF2Y | p9-3 | 040112 | 4 | 4 |
| 11. | EREF1Y | P9-3 | 051102 | 3 | 4 |
| 12. | EPHY | WD | 031023 | 3 | 3 |
| 13. | EPHIY | WD | 040419 | 3 | 6 |
| 14. | EPTY | N9-1 | 031023 | 3 | 2 |
| 15. | EAUY | P8-1 | 031023 | 3 | 1 |
| 16. | | | | 0 | 0 |
| 17. | ET1Y | Pt100 | 031023 | 4 | 15 |
| 18. | ECY | Methrom | 031023 | 3 | 7 |
| 19. | EKONDY | 29102 | 031023 | 4 | 10 |
| - | | | | 3 | 2 |
| - | | | | 0 | 0 |
| - | | | | 3 | 3 |
| - | | | | 3 | 7 |
| - | | | | 3 | 4 |
| tom | | | | 3 | 1 |
| tom | | | | 0 | 0 |
| - | Q | | | 4 | 9 |
| - | V1Y | - | | 3 | 19 |

Sond 3: 1000000111101111
Sond 4: 100001100001000

Figure A4-5. Electrode configuration, section 499.5-506.7 m.

Mätapplikation - SKB
File Special Development

Mätapplikation Huvudmeny MATDATOR1

Administration GivarKonf. B.Utr.Konf. Mätning Alarm Logga Ut
System Kemkal. LängdKal. Trend Forcerad mätn
Larmgränser Referenser GSM-larm HistLog Till kgn

Konfiguration av borrhålsutrustning

| Typ av enhet | Id | Längd, mm | Avstånd mellan multikoppling och tätning | Dummy Id |
|------------------|---------------|-----------|--|-------------|
| Multislang | Multislang S2 | 1 | | |
| Spår-detektor | SP022 | 1005 | | |
| Borrhålschemmac | Ke 021 | 1245 | | |
| Ö. Manschett | Övre mans S2 | 2065 | 500 | ingen |
| Hydr.Pump | Pump dubbel | 2290 | | ingen |
| Vattenprovtagare | PVP 022 | 2505 | | ingen |
| Ex. Behållare | Ex 021 | 1475 | | |
| N. Manschett | Nedre MA S2 | 2065 | 390 | ingen dummy |

Total sondlängd: 12650, mm
Längd till Övre Manschett: 3815, mm
Längd till Nedre Manschett: 10975, mm
Sektionslängd: 7160, mm

Figure A4-6. Configuration of downhole equipment, section 499.5-506.7 m.

Measurement information, KLX13A

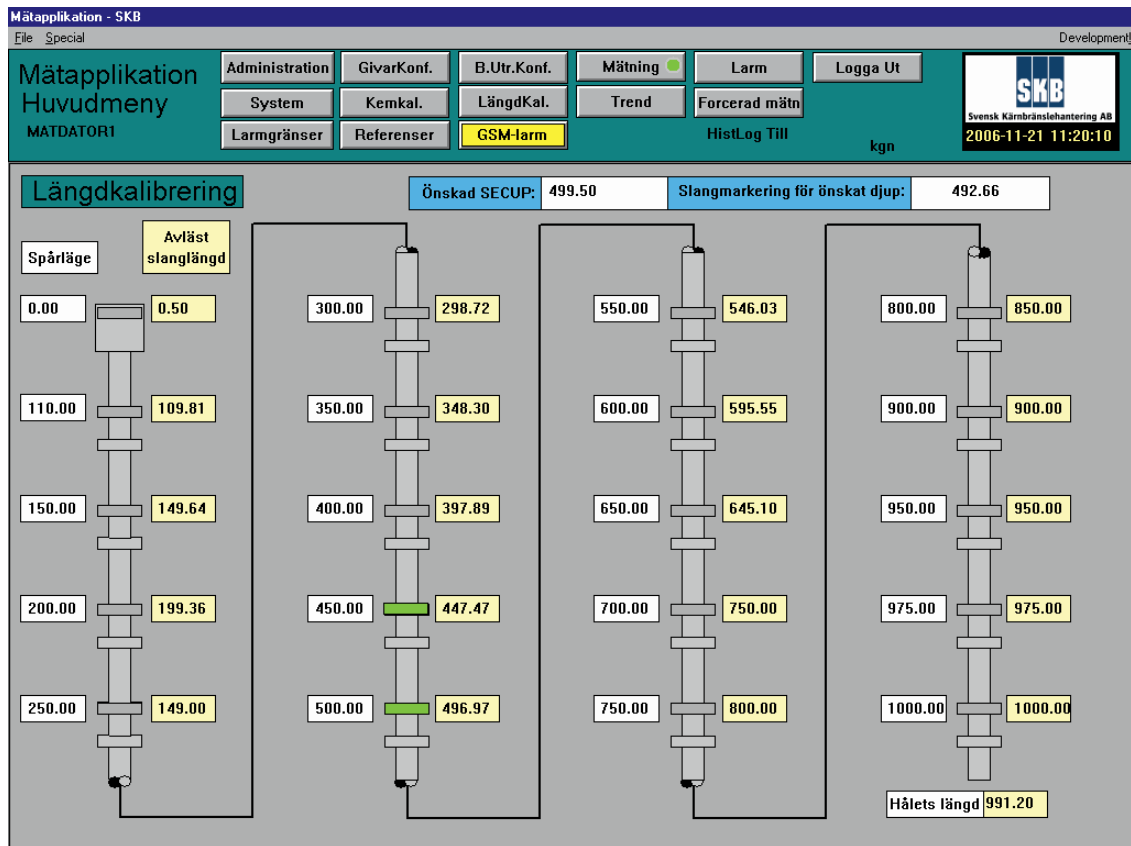

Figure A4-7. Length calibration, section 499.5-506.7 m.

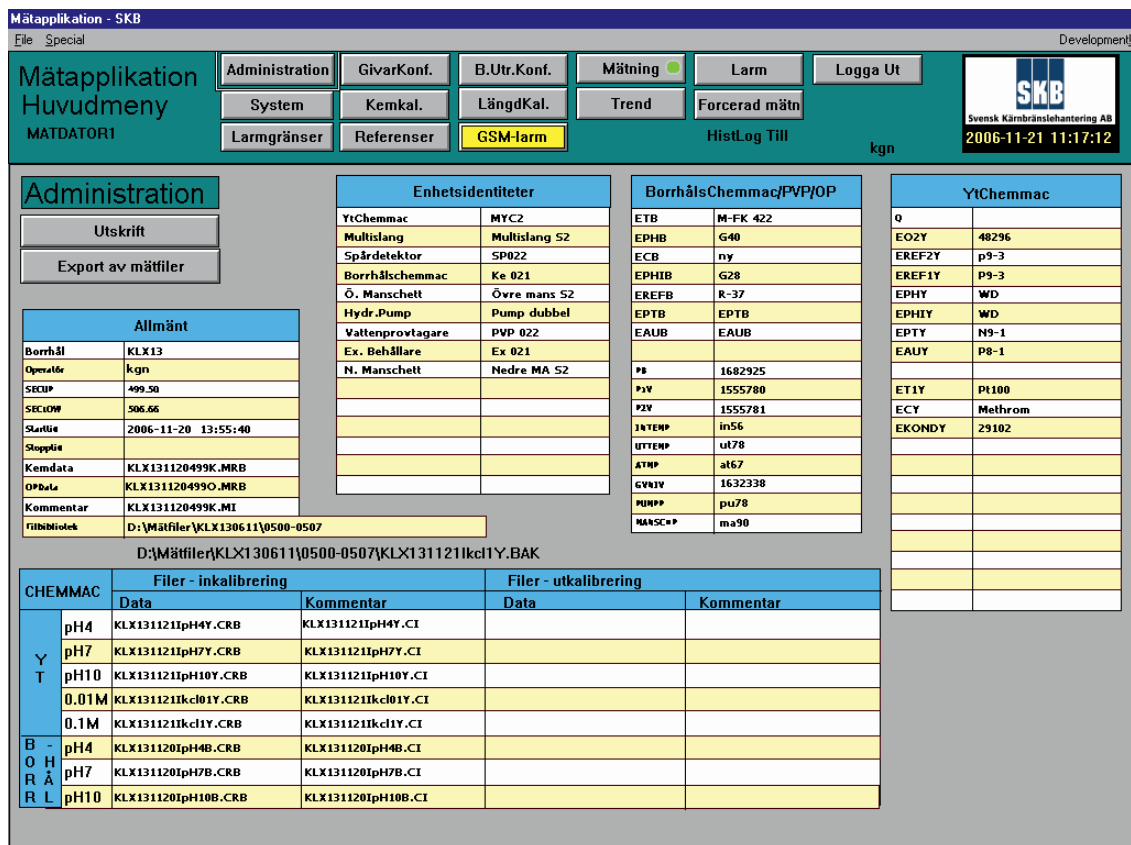

Figure A4-8. Administration, section 499.5-506.7 m.

Flow and pressure measurements in KLX13A

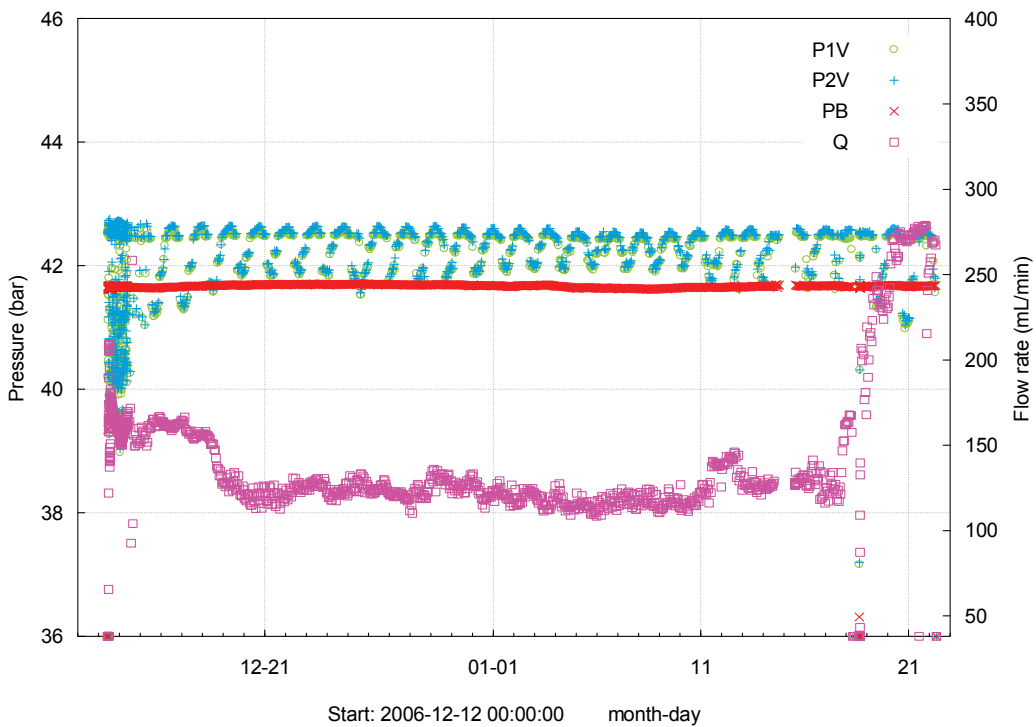

Figure A5-1. Pressure (P1V, P2V and PB) and flow rate (Q) measurements in borehole section 432.0-439.2 m. The P1V and P2V pressure sensors are placed in the in situ sampling unit and measure the pressure in the section. PB is the sensor in the borehole Chemmac and measures the pressure above the section.

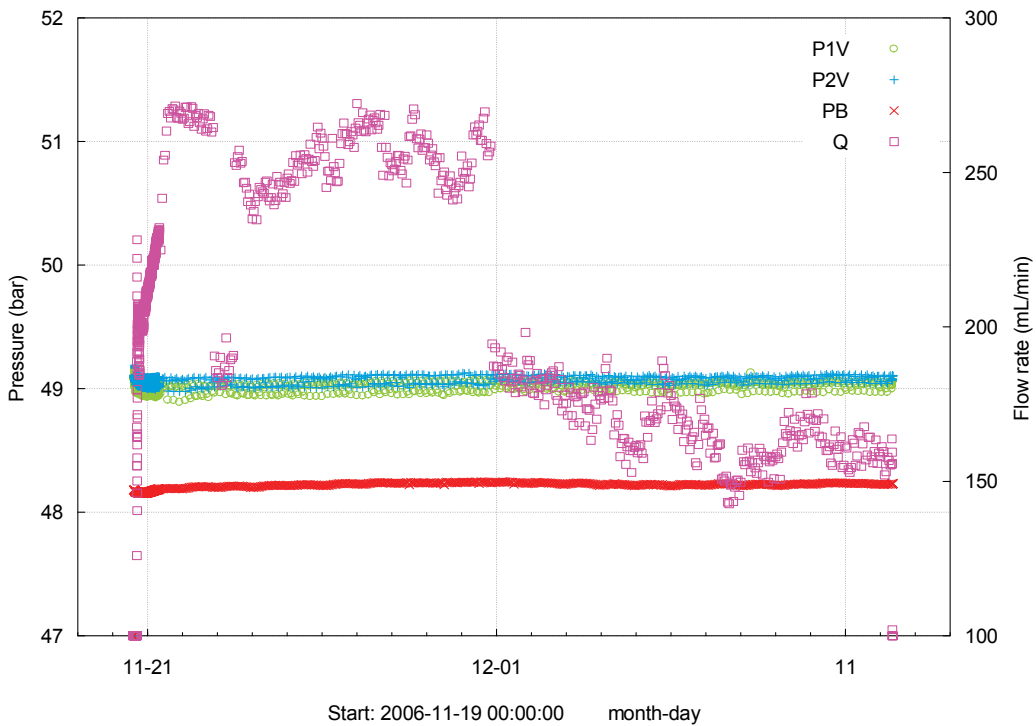

Figure A5-2. Pressure (P1V, P2V and PB) and flow rate (Q) measurements in borehole section 499.5-506.7 m. The P1V and P2V pressure sensors are placed in the in situ sampling unit and measure the pressure in the section. PB is the sensor in the borehole Chemmac and measures the pressure above the section.

Chemmac measurements in KLX13A, section 432.0-439.2 m

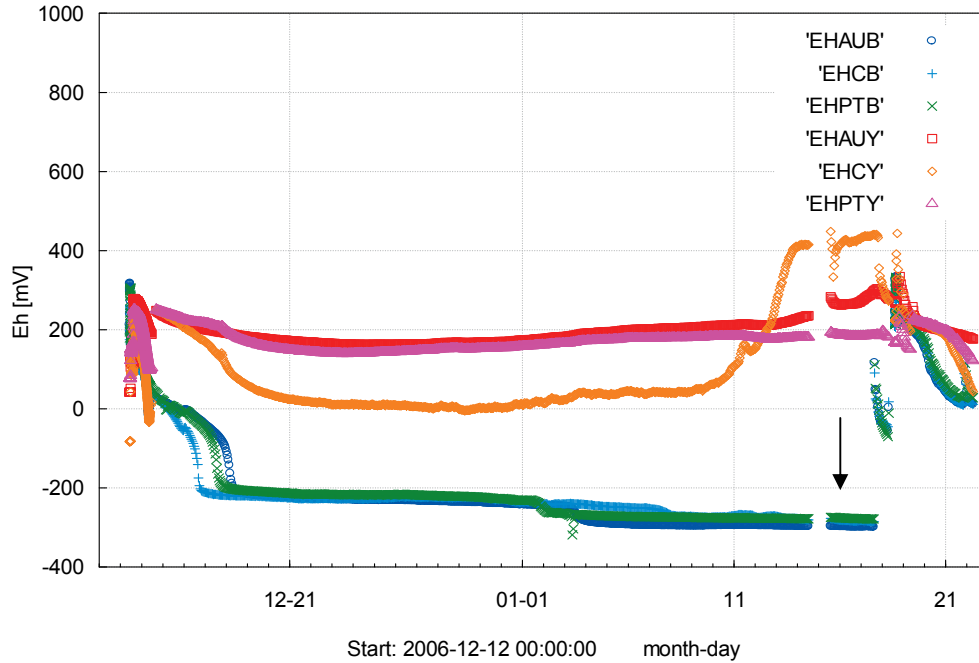

Figure A6-1. Redox potential measurements (Eh) by gold, glassy carbon and platinum electrodes in the borehole section (EHAUB, EHCB and EHPTB) and at the surface by gold, glassy carbon and platinum (EHAUY, EHCY and EHPTY). The arrow shows the chosen representative Eh values for the borehole section.

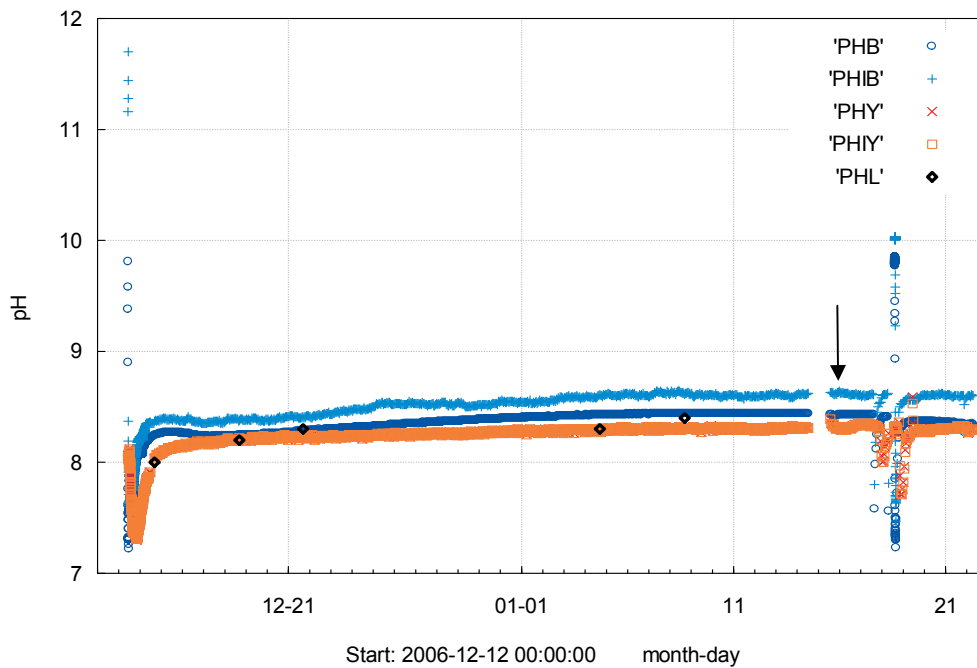

Figure A6-2. Measurements of pH by two glass electrodes in the borehole section (PHB and PHIB) and two glass electrodes at the surface (PHY and PHIY). The laboratory pH in each collected sample (PHL) is given for comparison. The arrow shows the chosen representative pH values for the borehole section.

Chemmac measurements in KLX13A, section 432.0-439.2 m

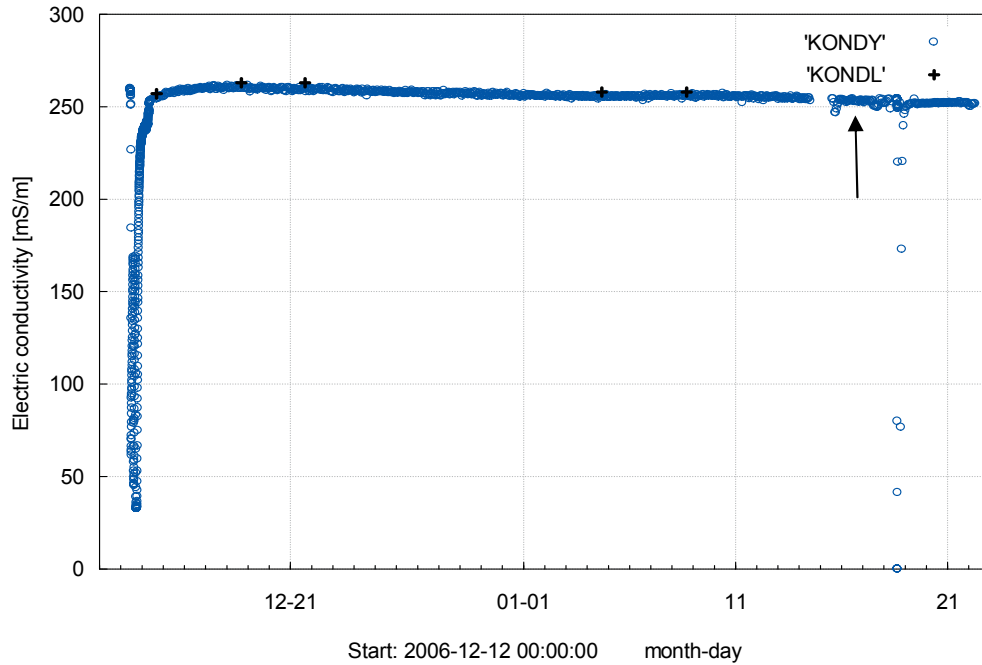

Figure A6-3. Electric conductivity measurements in the surface Chemmac cell (KONDY). The laboratory conductivity in each collected sample (KONDL) is given for comparison. The arrow shows the chosen representative electric conductivity value for the borehole section.

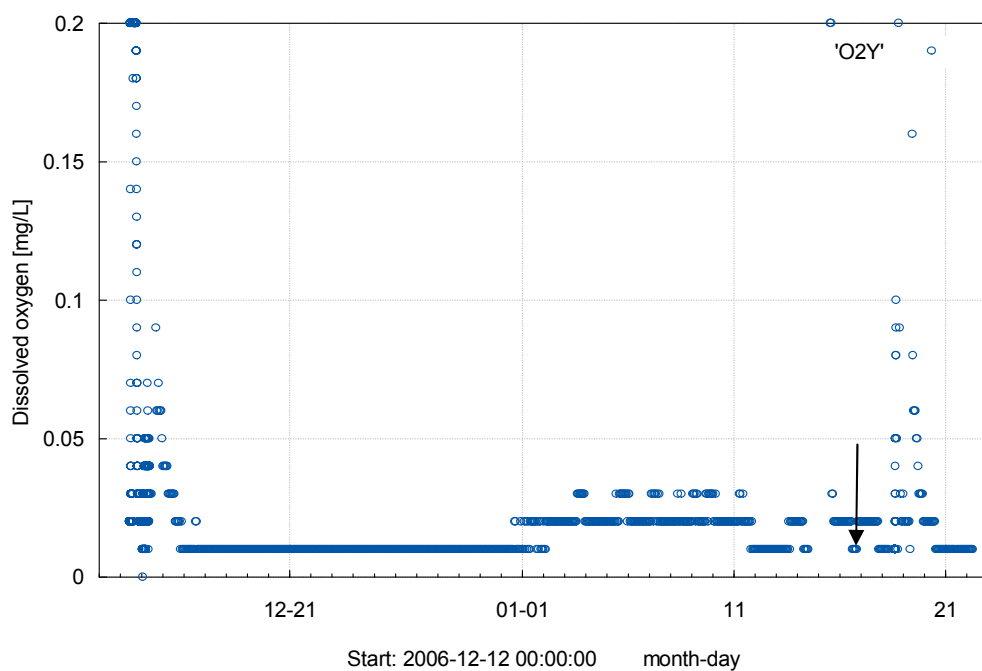

Figure A6-4. Dissolved oxygen measurements (O2Y) in the surface measurement cell. The arrow shows the chosen representative oxygen value for the borehole section.

Chemmac measurements in KLX13A, section 432.0-439.2 m

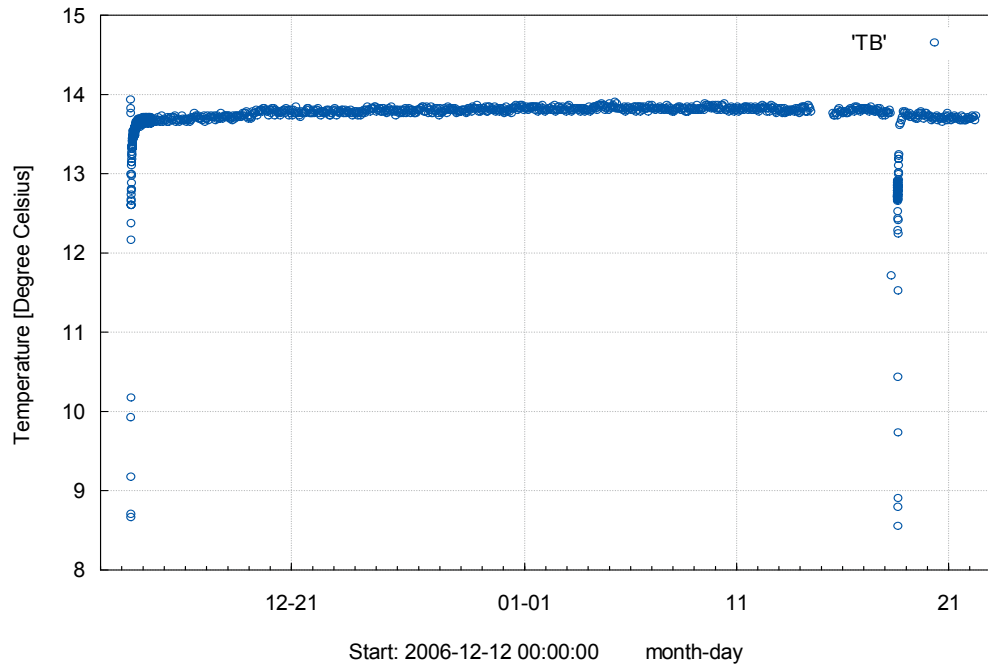

Figure A6-5. Temperature of the groundwater in the borehole section (TB).

Chemmac measurements in KLX13A, section 499.5-506.7 m

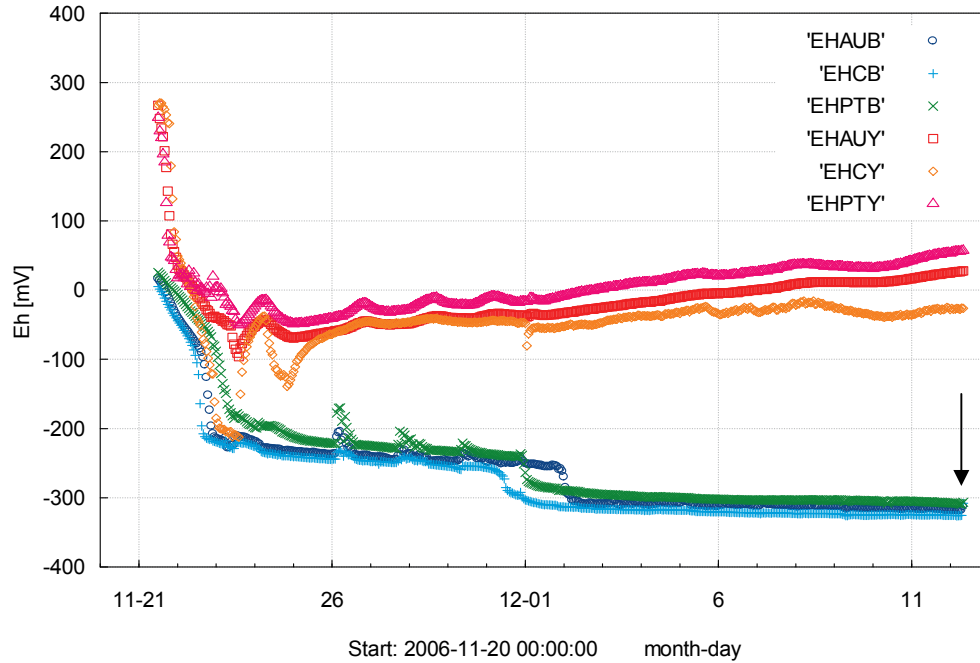

Figure A7-1. Redox potential measurements (Eh) by gold, glassy carbon and platinum electrodes in the borehole section (EHAUB, EHCB and EHPTB) and at the surface by gold, glassy carbon and platinum (EHAUY, EHCY and EHPTY). The arrow shows the chosen representative Eh values for the borehole section.

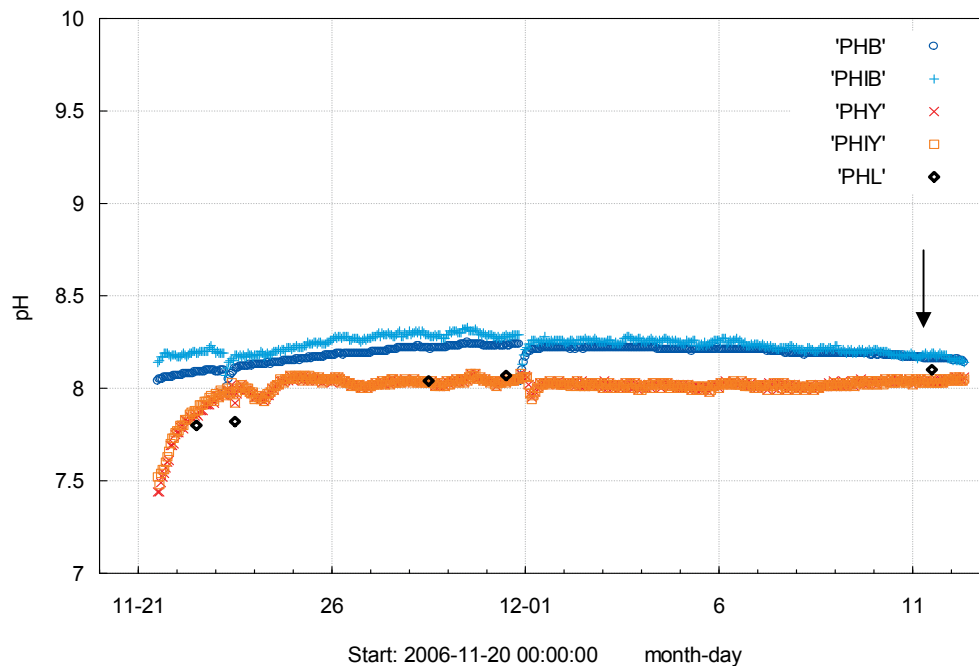

Figure A7-2. Measurements of pH by two glass electrodes in the borehole section (PHB and PHIB) and two glass electrodes at the surface (PHY and PHIY). The laboratory pH in each collected sample (PHL) is given for comparison. The arrow shows the chosen representative pH values for the borehole section.

Chemmac measurements in KLX13A, section 499.5-506.7 m

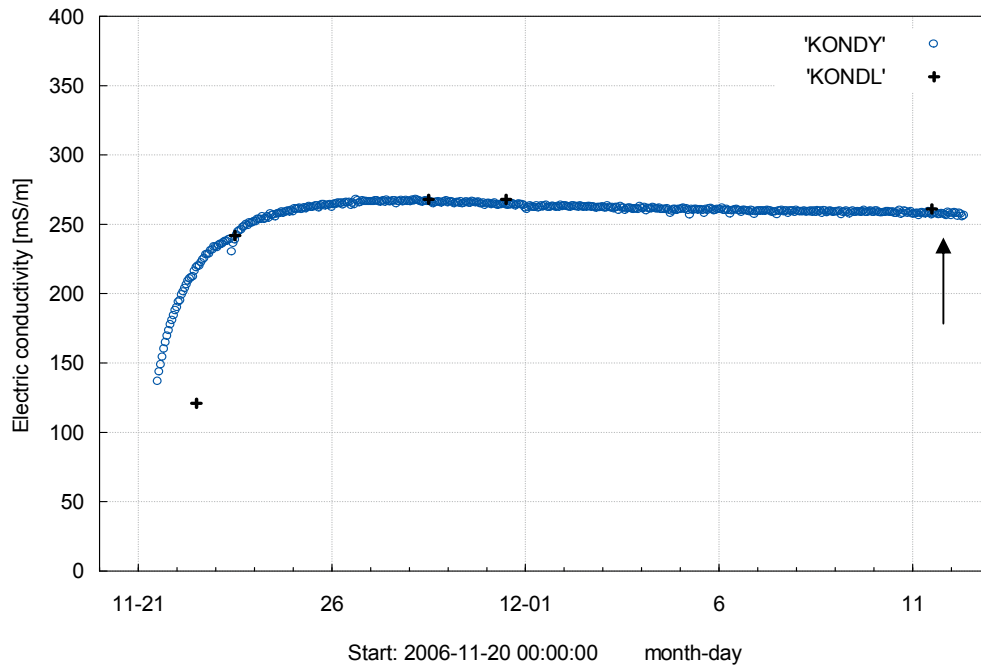

Figure A7-3. Electric conductivity measurements in the surface Chemmac cell (KONDY). The laboratory conductivity in each collected sample (KONDL) is given for comparison. The arrow shows the chosen representative electric conductivity value for the borehole section.

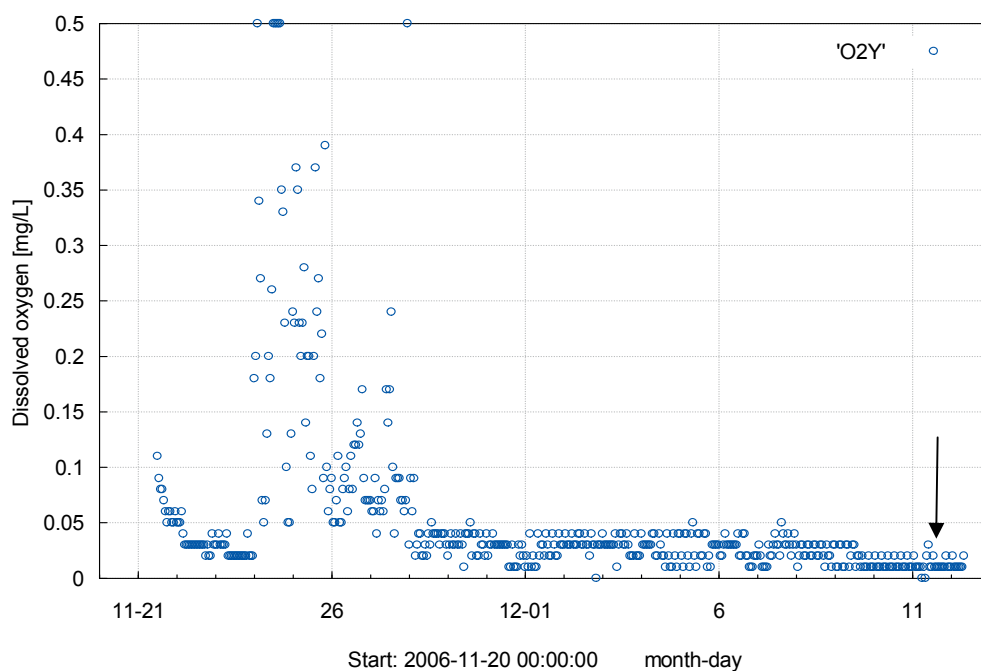

Figure A7-4. Dissolved oxygen measurements (O2Y) in the surface measurement cell. The arrow shows the chosen representative oxygen value for the borehole section.

Chemmac measurements in KLX13A, section 499.5-506.7 m

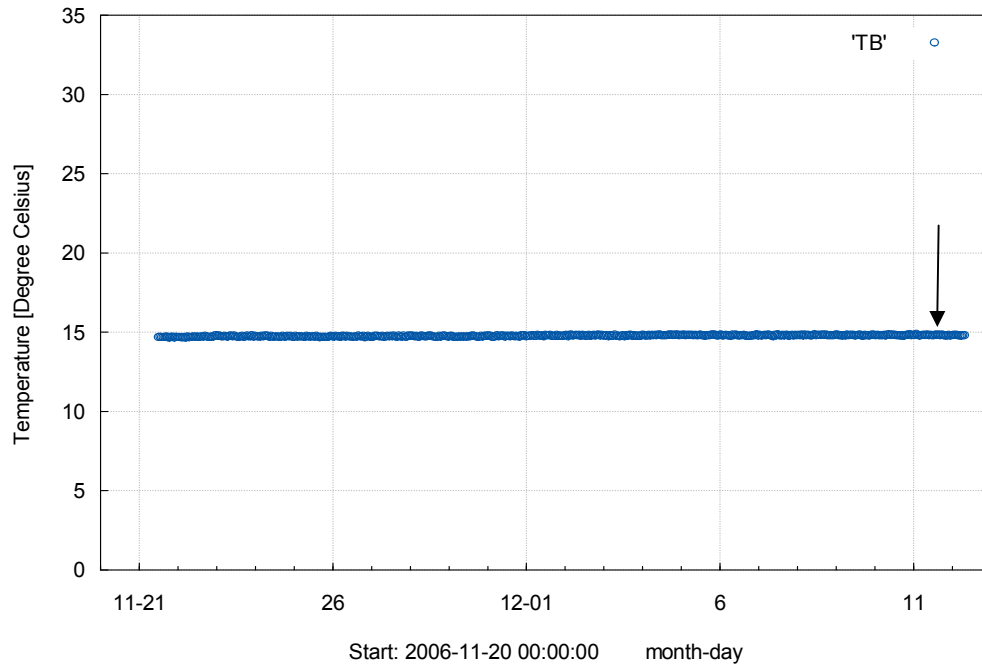

Figure A7-5. Temperature of the groundwater in the borehole section (TB).

Quantification of Colloids in Natural Groundwater from Laxemar Boreholes KLX13A, Section (432–439.2) m and KLX17A, Sections (642–701) and (416–437.5) m

W. Hauser, R. Götz, T. Schäfer, M. Bouby, H. Geckeis

Forschungszentrum Karlsruhe GmbH, Institut für Nukleare Entsorgung (INE)
P.O. Box 3640, D-76021 Karlsruhe, Germany

Introduction

Colloid analysis has been performed in groundwater samples collected during the site investigation program at Laxemar (Oskarshamns kommun), close to the nuclear power station Oskarshamn, Sweden. Samples from two boreholes and different sampling sections have been collected in stainless steel cylinders, preventing as much as possible the oxidation of the anoxic groundwater samples. They were sent to INE for laboratory analysis. Colloid analysis was subsequently performed by the laser-induced breakdown detection (LIBD) in the laboratory using a closed flow-through detection cell, again without atmosphere contact. Furthermore, a complete geochemical analysis of the water samples was performed.

It is supposed that the geological situation is similar to that found at various places in the Äspö tunnel. The aim of this study is to investigate the natural background colloid concentration in this specific boreholes and to compare the data with those obtained from other sites.

Experimental

LIBD instrumentation

The principle of LIBD is based on the generation of a dielectric breakdown in the focus region of a pulsed laser beam. As the threshold energy (irradiance) to induce a breakdown is lower for solids than for liquids or gas, the breakdown can be generated selectively in particles dispersed in solution at a suitable pulse energy.

A schematic diagram of the mobile LIBD set-up used in the present work is shown Fig. 1. A pulsed laser beam with a frequency of 15 Hz at 532 nm wavelength from a small Nd:YAG-laser (Continuum Minilite I) is focused (15 mm focal length) into the center of a flow-through detection cell, after passing through a variable attenuator and a beam splitter. The plasma generated at a breakdown event is monitored by a microscope equipped with a CCD monochrome camera triggered by the incident laser pulse and recorded by a PC controlled image processing system. A breakdown shock wave propagated in the sample solution is detected simultaneously by an acoustic sensor (piezoelectric transducer) that is connected to the surface of the cell. Both, the energy and the acoustic signal are recorded by an analog-digital converter interface in a PC. Colloid concentrations are derived from the respective breakdown probability, represented by the number of breakdown events per number of laser shots, and the range of breakdown events within the laser beam axis determined by optical inspection of the laser focus area within the flow through cell. Colloid number concentrations (N/ml) are given relative to a calibration with polystyrene reference colloids. Mass concentrations are calculated by assuming an average colloid density of 2.7 g/cm³ and spherical particle shape. A more detailed description of data evaluation is given in ¹.

Quantification of Colloids in Natural Groundwater from Laxemar Boreholes KLX13A, Section (432–439.2) m and KLX17A, Sections (642–701) and (416–437.5) m

The mobile instrumentation of LIBD is combined with a Millipore ultra-pure water processing unit for on-line cleaning the flow-through detection cell of LIBD and to allow for the frequent control of the instrument background. The whole system, which is set up to a compact mobile unit can be transported by a van for field experiments.

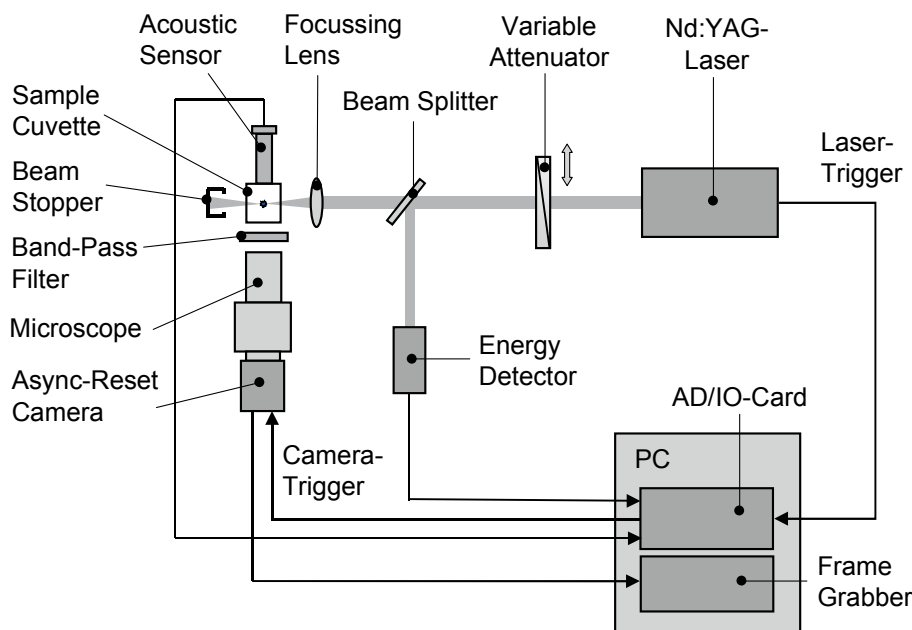

Fig. 1: Schematic diagram of the mobile laser-induced breakdown detection system

High-pressure flow-through detection cell

The LIBD has been operated in the CRR migration experiments (Grimsel Test-Site, Switzerland) ¹ under low pressure conditions with commercially available quartz detection cells (fluorescence cells) for batch (laboratory experiments) or flow-through sampling. These cells have a sample volume of 3 ml at 10 mm absorption length. A new flow-through detection cell has been developed constraining water pressures of about 35 bar for in situ investigations in the Äspö Hard Rock Laboratory access tunnel (Sweden) ², and in the Kraftwerke Oberhasli (KWO) access tunnel close to the Grimsel Test Site ³. This detection cell has also been applied in connection with a borehole sampling system for the detection of groundwater colloids sampled at a natural analogue site (Ruprechtov, Czech Republic).

Fig. 2 presents the high-pressure detection cell developed by INE. Without changing the optical path of the laser light, the detection cell fits into the same mount used for the silica cell. The new cell, fabricated from PEEK (polyether etherketone) is lined outside with a stainless steel housing (black parts in Fig. 2). Four optical windows, one at each side are applied for the passing laser light (absorption length 12 mm), the microscope and for inspection. They consist of sapphire with 2 mm thickness. The groundwater flow enters the inner cell volume of 0.8 ml from the base via a

Quantification of Colloids in Natural Groundwater from Laxemar Boreholes KLX13A, Section (432–439.2) m and KLX17A, Sections (642–701) and (416–437.5) m

PEEK tubing. The outlet is on the top of the cell. The high-pressure detection cell is successfully tested for a water pressure up to 60 bar.

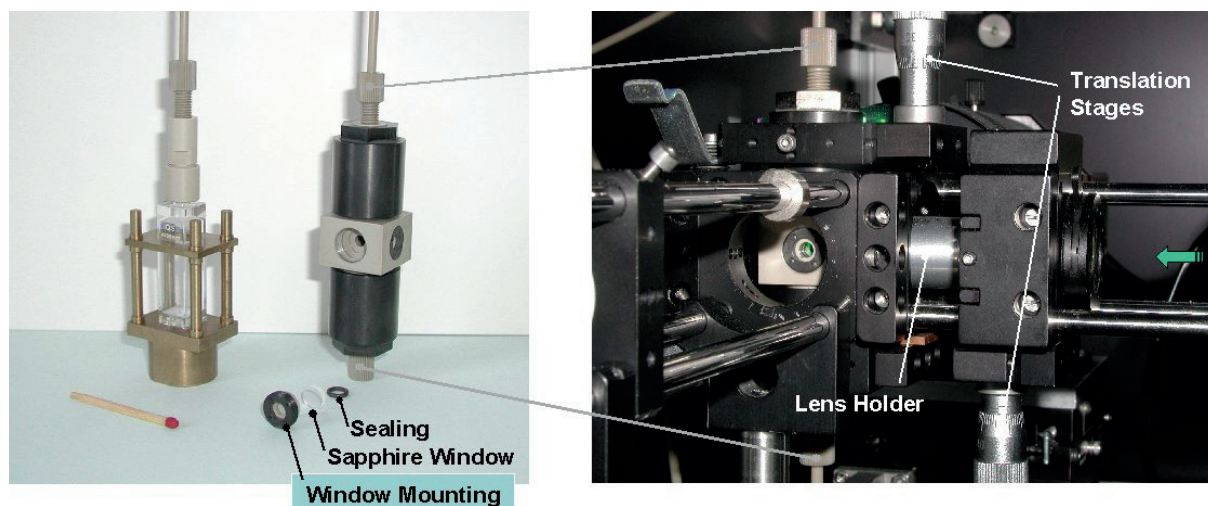

Fig. 2: LIBD high-pressure flow-through detection cell (left: conventional flow-through silica detection cell)

Borehole sampling

Samples were taken

... at January 22, 2007 from Laxemar borehole KLX13A, section between (432 – 439.16) m. The vertical depth was approximately 430 m with a measured pressure in the borehole section of 42 bar. The samples are filled in the SKB steel cylinders PVB 203 and PVB 025.

... at February 27, 2007 from Laxemar borehole KLX17A, section between (642 – 701.08) m. The vertical depth was (548.6 – 600) m with a measured pressure in the borehole section of 54 bar. The samples are filled in the SKB steel cylinders PVB 201 and PVB 9506-1.

... at April 24, 2007 from Laxemar borehole KLX17A, section between (416 – 437.51) m. The vertical depth was (361 – 379) m with a measured pressure in the borehole section of 35 bar. The samples are filled in the SKB steel cylinders PVB 024 and PVB 9506-4.

The stainless steel cylinders (Fig. 3) are groundwater sampling cylinders from SKB with a sample volume of about 190 ml each. They are supplied with an internal piston and 3 valves. Further information concerning the sampling procedure is given elsewhere (SKB).

In general one day after sampling the cooled samples arrived at the INE where they have been stored in a fridge (Temp. about 10 °C) until colloid detection several days later.

Quantification of Colloids in Natural Groundwater from Laxemar Boreholes KLX13A, Section (432–439.2) m and KLX17A, Sections (642–701) and (416–437.5) m

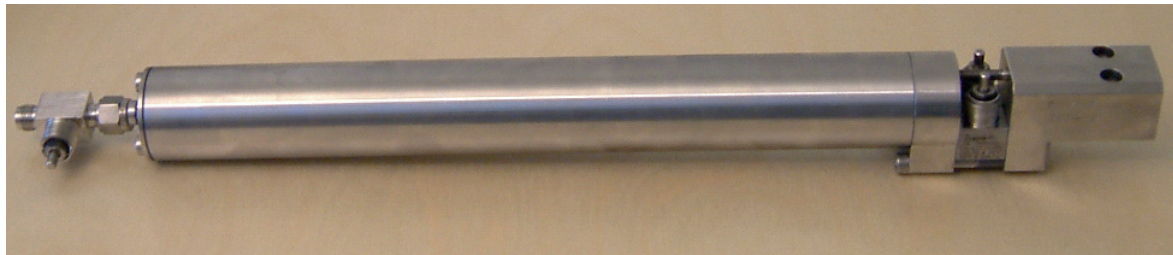

Fig. 3: SKB stainless steel sampling cylinder
(left: piston side, right: mounting adapter side)

Configuration of laboratory experiments

Each sampling cylinder was connected with the LIBD detection cell and the detection cells for pH-, Eh-, electrical conductivity-, oxygen content-detection and for taking samples for chemical groundwater analysis. As far as possible pressure resistant versions of the sensors are selected. In the specifications of the Eh- / pH- electrodes (Hamilton POLILYTE PLUS / POLILYTE PRO) a maximum groundwater pressure of 50 bar is designated. The maximum pressure for the oxygen-detector (Mettler Toledo InPro 6900) is specified with 6 bar and the electrical conductivity-detector (InPro 7000-VP) is 34 bar.

A scheme of the corresponding laboratory setup is plotted in Fig. 4 with an image of the experimental configuration in Fig. 5.

At first the tubings around the sampling cylinder are intensively cleaned by evacuation and flushing with Argon. Then a HPLC-pump is used to fill all tubings on the water side of the sampling cylinder with ultra-pure water and to set the water pressure according the hydrostatic pressure of the samples. This was the expected water pressure in the sampling cylinder. The gas side of the sampling cylinder is then filled with the corresponding Argon gas pressure.

Now one of the top valves of the sampling cylinder can be opened without contact of the sampled groundwater with atmospheric oxygen. With Argon gas the groundwater is pressed out from the sampling cylinder through the LIBD detection cell via a degasser to avoid occasionally occurring gas bubbles which interfere the colloid detection. Behind the LIBD system additional detection cells with pressure resistant electrodes for Eh, pH (back pressure regulator 1 set to 40 bar), Oxygen, a sensor for electrical conductivity and a sensor for the pressure detection are arranged downstream.

Quantification of Colloids in Natural Groundwater from Laxemar Boreholes KLX13A, Section (432–439.2) m and KLX17A, Sections (642–701) and (416–437.5) m

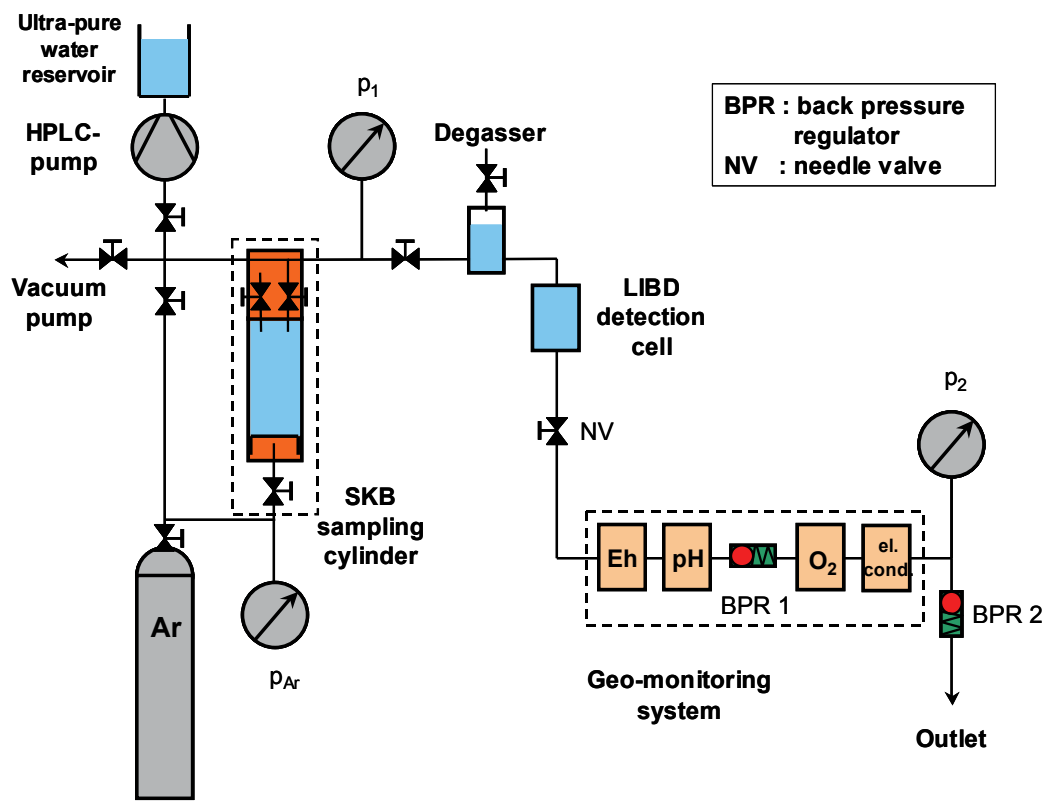

Fig. 4: Scheme of the laboratory setup for in-line LIBD colloid analysis and groundwater monitoring

Before the sampling outlet an additional back pressure regulator, set to 5 bar, is installed. This overpressure in the whole system avoids further contact to oxygen. Data of this geo-monitoring system are stored on a personal computer with a data logger as a function of time. This allows to separate temporary fluctuating data, especially during the starting period when the detection cell and the geo-monitoring system are contaminated and do not contain the sampled groundwater, respectively.

Groundwater batch samples are collected at the outlet of the pressure regulator for chemical analysis with ICP-AES, ICP-MS and for the detection of inorganic carbon (IC) and dissolved organic carbon (DOC).

Additionally, track-etched Polycarbonate filter samples (pore size 50 nm) have been taken for colloid analysis with SEM/EDX.

Quantification of Colloids in Natural Groundwater from Laxemar Boreholes KLX13A, Section (432–439.2) m and KLX17A, Sections (642–701) and (416–437.5) m



Fig. 5: Experimental configuration

Results

Chemical analysis

Data from geo-monitoring as well as the chemical composition of six samples (two from the same groundwater) are displayed in Table 1.

The groundwater pH of (8.0 – 8.5) is equivalent to the pH detected so far in other Forsmark (7.3 – 8.4) and Äspö groundwater samples (7.3 – 7.8). In the experiments only for groundwater KLX17A (416 – 437.51) m the Eh could be detected. Due to the malfunction of the electrode the other Eh-values have not been detected. They are calculated with PHREEQC assuming that $1 \cdot 10^{-7}$ mol/l of the Fe_{tot} measured is in the form of ferric iron. This assumption is based on the pH dependent solubility for iron oxides/hydroxides given in ⁵.

Additionally, the oxygen values (Table 1) demonstrate that geochemical conditions are maintained within all sampling containers during transport, storage and colloid detection. This indicates that a significant intrusion of atmosphere oxygen did not occur. In two groundwater containers an oxygen concentration of ~0.010 mg/l was detected. As these detected values are slightly higher than the sensors detection limit (0.001 mg/l) it might be caused by sensor instabilities (see logged raw data) during the measurement.

Quantification of Colloids in Natural Groundwater from Laxemar Boreholes KLX13A, Section (432–439.2) m and KLX17A, Sections (642–701) and (416–437.5) m

All three Laxemar groundwaters are determined by their low Cl⁻ -content of 20 mg/l and 750 mg/l, respectively. Whereas the chemical composition of Äspö and Forsmark groundwater is mainly characterized by the salinity from 3000 to 14000 mg/l chloride. The Laxemar DOC is comparable to the DOC of the Äspö groundwater KR0012B of the same salinity ⁶.

It is supposed that differences in the K⁺-concentration of different samples of the same groundwater (Table 1: LX5A, LX6A), might be caused by a K⁺-contamination from the electrode storage solution, or a bleeding of Eh- / pH-sensor gel into the analyzed sample (... similar for differences in the SO₄²⁻ -concentration (Table 1: LX3B, LX4C))

Table 1: Monitored data of pH, Eh, el. conductivity, oxygen content and chemical analysis of the groundwater samples from Laxemar boreholes KLX13A, KLX17A

| Borehole ID | | KLX13A | | KLX17A | | KLX17A | |
|-----------------------------------|------|--------------|-------------|---------------|----------------|-------------|----------------|
| Secup - Seclow | m | 432 - 439.16 | | 642 - 701 | | 416 - 437.5 | |
| Sampling depth | m | ~ 420 | | 548.6 - 600.1 | | 361 - 379 | |
| Hydr. pressure | bar | 42 | | 54 | | 35 | |
| Container ID | | SKB PVB 203 | SKB PVB 025 | SKB PVB 201 | SKB PVB 9506-1 | SKB PVB 024 | SKB PVB 9506-4 |
| Sample ID | | LX1A | LX2A | LX3B | LX4C | LX5A | LX6A |
| pH | | 8.2 | 8.5 | 8.45 | 8.39 | 8.1 | 7.94 |
| Redox (Ag/AgCl) | mV | [-209] | [-260] | [-286] | [-278] | -237 | -217 |
| Eh (SHE) | mV | [5] | [-46] | [-72] | [-64] | -23 | -3 |
| el. cond. | mS/m | 256 | 256 | 51 | 58 | 224 | 220 |
| O ₂ content | mg/l | <0.011 | <0.008 | <0.002 | <0.001 | <0.029 | <0.015 |
| Na ⁺ | mg/l | 438 | 423 | 93.1 | 89.3 | 327 | 314 |
| K ⁺ | mg/l | 11.3 | 9.46 | 8.4 | 7.51 | 23.4 | 7.96 |
| Ca ²⁺ | mg/l | 49.1 | 48.2 | 12.2 | 12.2 | 72.9 | 72.4 |
| Mg ²⁺ | mg/l | 2.68 | 2.71 | 2.31 | 2.21 | 9.7 | 9.7 |
| Al ²⁺ | mg/l | 0.01 | 0.01 | 0.05 | 0.04 | 6.95 | 6.95 |
| HCO ₃ ⁻ (a) | mg/l | 69.5 | 70.5 | 231 | 229 | 106.2 | 106.3 |
| Cl ⁻ | mg/l | 750 | 762 | 17.4 | 21.9 | 758.1 | 679.2 |
| SO ₄ ²⁻ | mg/l | 27.8 | 22.6 | 3.78 | 1.51 | 21.1 | 20.7 |
| Br ⁻ | mg/l | 3.98 | 3.6 | <0.1 | <0.1 | 2.7 | 2.3 |
| F ⁻ | mg/l | 7.1 | 5.4 | 2.75 | 3.89 | 2 | 2.1 |
| Si ⁴⁺ | mg/l | 4.74 | 4.89 | <0.001 | <0.001 | 6.9 | 7.06 |
| Fe-ICP | mg/l | 0.086 | 0.078 | 0.37 | 0.4 | 0.216 | 0.233 |
| Mn ²⁺ | mg/l | 0.02 | 0.02 | 0.03 | 0.04 | 0.08 | 0.08 |
| Li ⁺ | mg/l | 0.07 | 0.07 | 0.016 | 0.016 | 0.05 | 0.05 |
| Sr ²⁺ | mg/l | 4.74 | 4.89 | 6.73 | 6.88 | 2.3 | 2.35 |
| DOC | mg/l | 16.5 | 13.9 | 16.85 | 21.44 | 24.8 | 20.9 |
| IC | mg/l | 13.7 | 13.9 | 45.5 | 45 | 8.3 | 21 |

(a) calculated from IC

[] Redox, Eh calculated with PHREEQC

Quantification of Colloids in Natural Groundwater from Laxemar Boreholes KLX13A, Section (432–439.2) m and KLX17A, Sections (642–701) and (416–437.5) m

Colloid analysis

Groundwater from KLX13A (432 – 439.16) m

Data determined with the laser-induced breakdown detection system are listed in Table 2. The volume of the samples was sufficient to perform four or five colloid measurements for each PVB container (see logged raw data). So temporal variations in the colloid concentration during the elution of the groundwater can be detected.

After evaluation of image processed data colloid size distributions with two main average colloid fractions are derived. A 1st colloid fraction with diameters of 60 - 110 nm with corresponding mass concentrations of 2 - 5 µg/l are calculated. During the elution of container PVB 203 a higher colloid concentration of 40 µg/l is detected. This might be caused by mobilized larger colloids (diameter 356 nm) which previously have settled down on the container bottom (piston surface).

1100 – 1400 nm particles with mass concentrations of 680 – 1380 µg/l are the main part of the 2nd colloid fraction. This 2nd fraction contains more than 99 % of the total particle mass, whereas the total colloid number density is determined of the 1st (smaller) colloid fraction.

Table 2: LIBD data with average colloid diameter and colloid concentration of the analyzed groundwater from Laxemar borehole KLX13A, (432 – 439.16) m

| Borehole ID | | KLX13A | | | | | KLX13A | | | |
|--------------------------------|------|-------------|---------|---------|---------|---------|-------------|---------|---------|---------|
| Secup - Seclow | m | 432-439.16 | | | | | 432-439.16 | | | |
| Sampling depth | m | ~ 420 | | | | | ~ 420 | | | |
| Hydr. pressure | bar | 42 | | | | | 42 | | | |
| Container ID | | SKB PVB 203 | | | | | SKB PVB 025 | | | |
| LIBD /det. ID | | LX1A | LX1B | LX1C | LX1D | LX1E | LX2A | LX2B | LX2C | LX2D |
| Trigger-pulses | | 2000 | 2000 | 2000 | 2000 | 2500 | 2000 | 2000 | 2000 | 2000 |
| 1st coll. fraction (1): | | | | | | | | | | |
| BD-events | | 366 | 324 | 365 | 204 | 260 | 286 | 186 | 151 | |
| BD-probability | | 0.183 | 0.162 | 0.183 | 0.102 | 0.104 | 0.143 | 0.093 | 0.076 | |
| coll. num. density | N/ml | 3.2E+06 | 5.6E+06 | 6.3E+05 | 2.1E+06 | 1.5E+06 | 3.5E+06 | 2.0E+06 | 1.3E+06 | |
| coll. diam. | nm | 101 | 58 | 356 | 85 | 113 | 76 | 83 | 95 | |
| coll. mass conc. | µg/l | 5 | 2 | 40 | 2 | 3 | 2 | 2 | 2 | |
| 2nd coll. fraction (2): | | | | | | | | | | |
| BD-events | | 964 | 892 | 783 | 759 | 976 | 807 | 936 | 943 | 1351 |
| BD-probability | | 0.482 | 0.446 | 0.392 | 0.38 | 0.39 | 0.404 | 0.468 | 0.472 | 0.676 |
| coll. num. density | N/ml | 3.5E+05 | 3.9E+05 | 2.5E+05 | 2.8E+05 | 3.6E+05 | 3.9E+05 | 5.9E+05 | 7.5E+05 | 2.0E+06 |
| coll. diam. | nm | 1408 | 1200 | 1470 | 1302 | 1097 | 1076 | 910 | 757 | 559 |
| coll. mass conc. | µg/l | 1379 | 941 | 1121 | 875 | 677 | 683 | 626 | 462 | 485 |
| Sum (1)+(2): | | | | | | | | | | |
| coll. num. density | N/ml | 3.5E+06 | 6.0E+06 | 8.8E+05 | 2.4E+06 | 1.9E+06 | 3.9E+06 | 2.6E+06 | 2.1E+06 | 2.0E+06 |
| coll. mass conc. | µg/l | 1384 | 943 | 1161 | 877 | 680 | 685 | 628 | 464 | 485 |

Fig. 6 shows the corresponding SEM images of groundwater KLX13A (432–439.16) m colloids. It is evident that two major colloid fractions exist. A 1st small colloid fraction has a size ≤ 100 nm. This seems to be the component with the highest number density. The 2nd particle fraction (500 – 1000) nm is the component with

Quantification of Colloids in Natural Groundwater from Laxemar Boreholes KLX13A, Section (432–439.2) m and KLX17A, Sections (642–701) and (416–437.5) m

the lowest number density. Some particles seem to be agglomerates of the 1st fraction (Fig. 6a, b).

In this case EDX element analysis was not possible because of the small quantities of colloidal material.

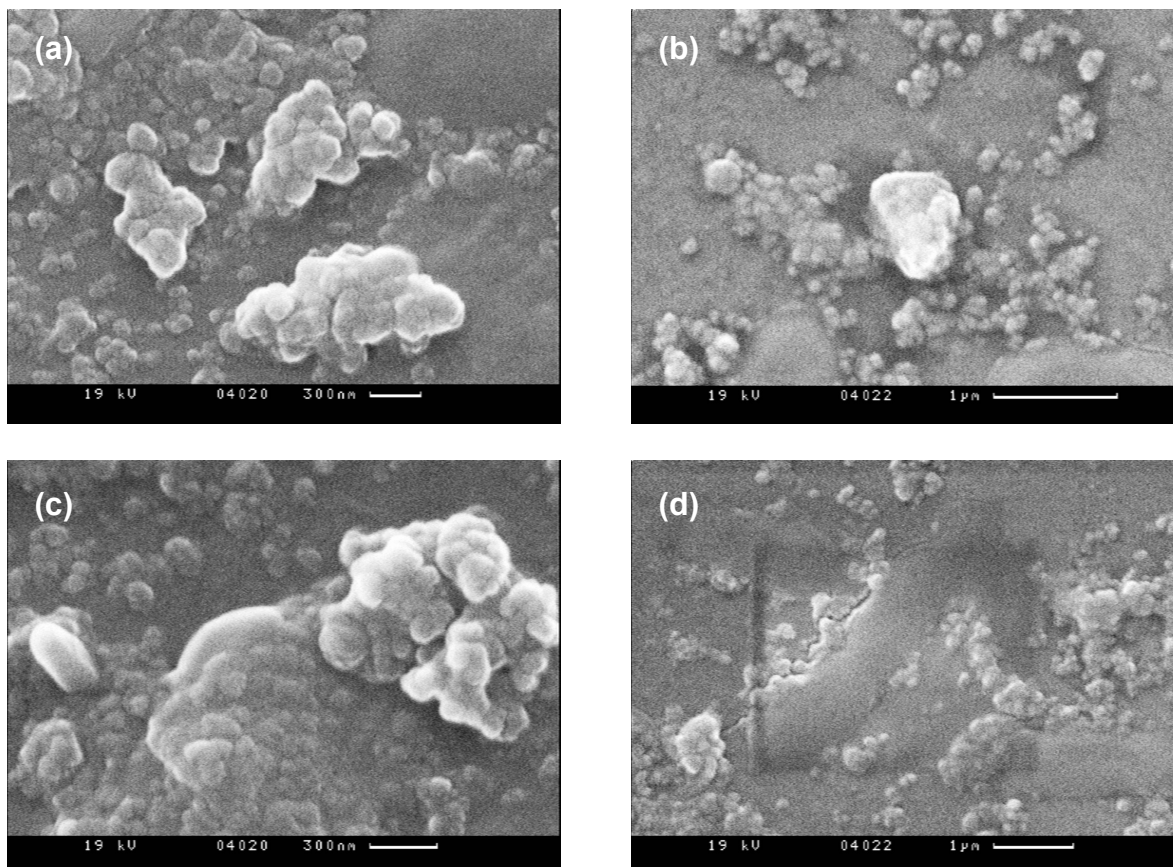

Fig. 6: SEM images of groundwater KLX13A (432 – 439.16) m colloids on a 50 nm track-etched Polycarbonate filter

Groundwater from KLX17A (642 – 701.08) m

After starting the elution of groundwater KLX17A (642 – 701.08) m the LIBD detected breakdown probability increased from 0 % to 100 %. Even after 120 min. detection the breakdown probability did not decrease. The same effects occurred with the groundwater from both sampling cylinders PVB 201 and PVB 9506-1 (see logged raw data).

This means that the amount of particles is higher than LIBD can detect, or in other words LIBD is too sensitive for the given samples.

SEM images of this groundwater (Fig. 7) show a big amount of colloids with diameter from about 100 nm, 300 nm, and more. Even bacteria are found. With EDX analyzed elements are Al, Si (alumino-silicates, silicates), F, Fe.

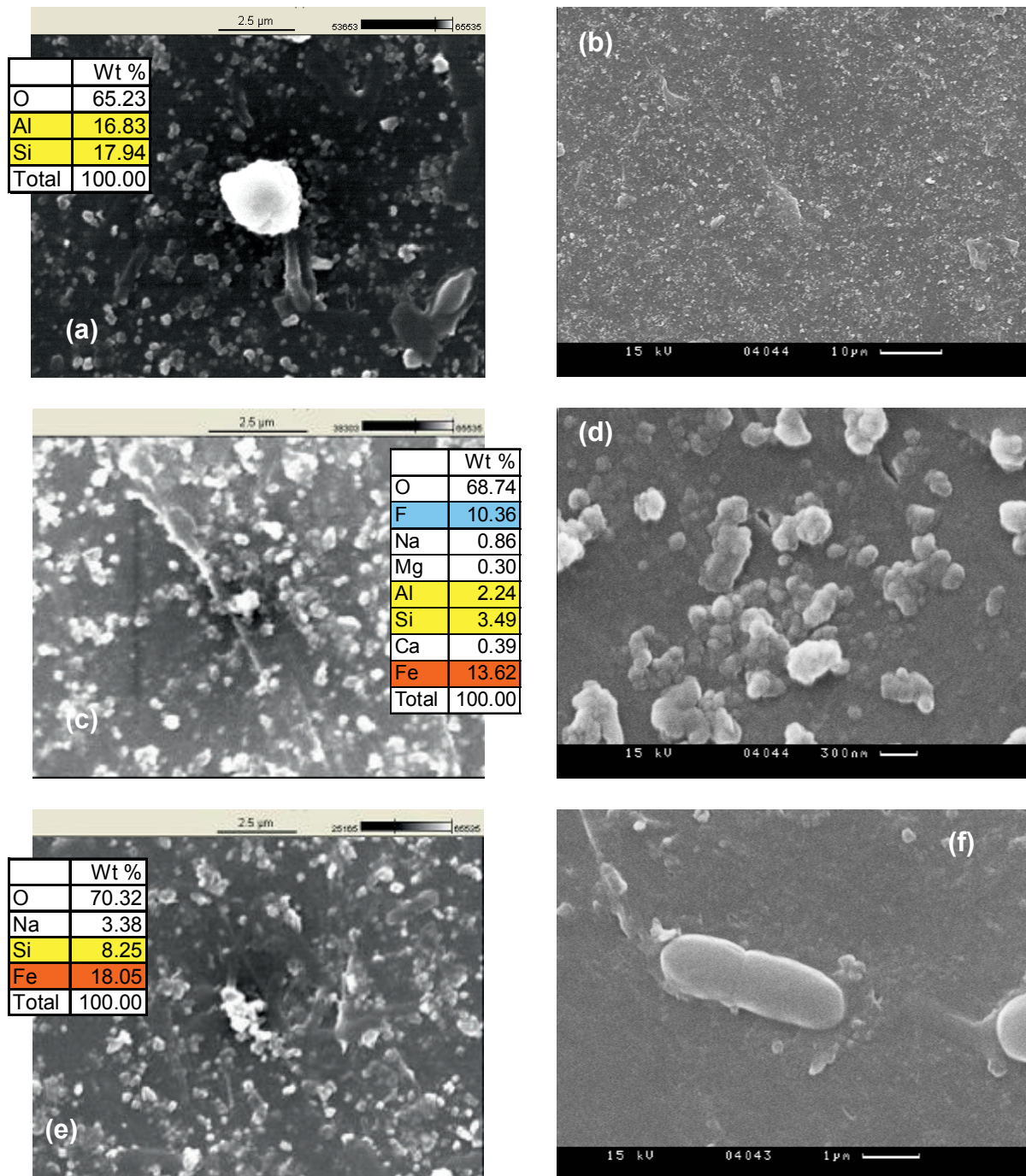

Fig. 7: SEM images of groundwater KLX17A (642 – 701.08) m colloids on a 50 nm track-etched Polycarbonate filter

Groundwater from KLX17A (416 – 437.51) m

The same borehole has been sampled again with two steel cylinders, but from about 200 m higher borehole sections. With each groundwater sample seven LIBD colloid measurements (Table 3) are performed, again to quantify temporal fluctuations caused by changing flow conditions.

During groundwater elution from SKB steel cylinder PVB 024 colloids with an average diameter between (360 – 470) nm and corresponding mass concentrations of (210 – 280) μg/l are detected. About a factor of 2 lower are the colloid mass concentrations of the same groundwater taken from steel cylinder PVB 9506-4.

This difference is significant and it is not clear where it comes from. Possible reasons can be

- differences in the degree of cleaning and flushing with inert gas of each steel cylinder before its use for sampling,
- differences of the filling procedure of the cylinders during sampling in the Laxemar borehole (e.g. erosion of additional colloids),
- ...

Table 3: LIBD data with average colloid diameter and colloid concentration of the analyzed groundwater from Laxemar borehole KLX17A, (416 – 437.51) m

| Borehole ID | | KLX17A | | | | KLX17A | | | |
|--------------------|------|-------------|---------|---------|---------|----------------|---------|---------|---------|
| Secup - Seclow | m | 416-437.5 | | | | 416-437.5 | | | |
| Sampling depth | m | 361-379 | | | | 361-379 | | | |
| Hydr. pressure | bar | 35 | | | | 35 | | | |
| Container ID | | SKB PVB 024 | | | | SKB PVB 9506-4 | | | |
| LIBD /det. ID | | LX5A | LX5B | LX5C | LX5D | LX6A | LX6B | LX6C | LX6E |
| BD-events | | 1266 | 1319 | 1286 | 1218 | 1053 | 1057 | 975 | 1373 |
| Trigger-pulses | | 2000 | 2000 | 2000 | 2000 | 2000 | 2000 | 2000 | 3000 |
| BD-probability | | 0.633 | 0.66 | 0.643 | 0.609 | 0.527 | 0.529 | 0.4875 | 0.458 |
| coll. num. density | N/ml | 2.7E+06 | 3.0E+06 | 3.2E+06 | 2.5E+06 | 3.0E+06 | 3.0E+06 | 2.1E+06 | 2.3E+06 |
| coll. diam. | nm | 398 | 388 | 359 | 402 | 289 | 291 | 350 | 306 |
| coll. mass conc. | µg/l | 241 | 248 | 208 | 230 | 104 | 106 | 129 | 94 |
| LIBD /det. ID | | LX5E | LX5F | LX5G | | LX6F | LX6G | LX6H | |
| BD-events | | 1083 | 1174 | 1167 | | 869 | 1089 | 1063 | |
| Trigger-pulses | | 1769 | 2000 | 2000 | | 1662 | 2000 | 2000 | |
| BD-probability | | 0.612 | 0.587 | 0.584 | | 0.523 | 0.545 | 0.532 | |
| coll. num. density | N/ml | 2.7E+06 | 1.9E+06 | 2.2E+06 | | 3.6E+06 | 3.4E+06 | 2.5E+06 | |
| coll. diam. | nm | 382 | 470 | 425 | | 254 | 279 | 341 | |
| coll. mass conc. | µg/l | 213 | 283 | 236 | | 83 | 103 | 140 | |

Corresponding SEM images in Fig. 8 show colloids starting from a size around 100 nm (Fig. 8 (f)). They look like agglomerates (Fig. 8 (d)) of a basic form of colloids which was also found in other groundwater samples (Fig. 6, Fig. 7). Larger particles (several µm) consist of Si, Fe, Ca, Al / Si.

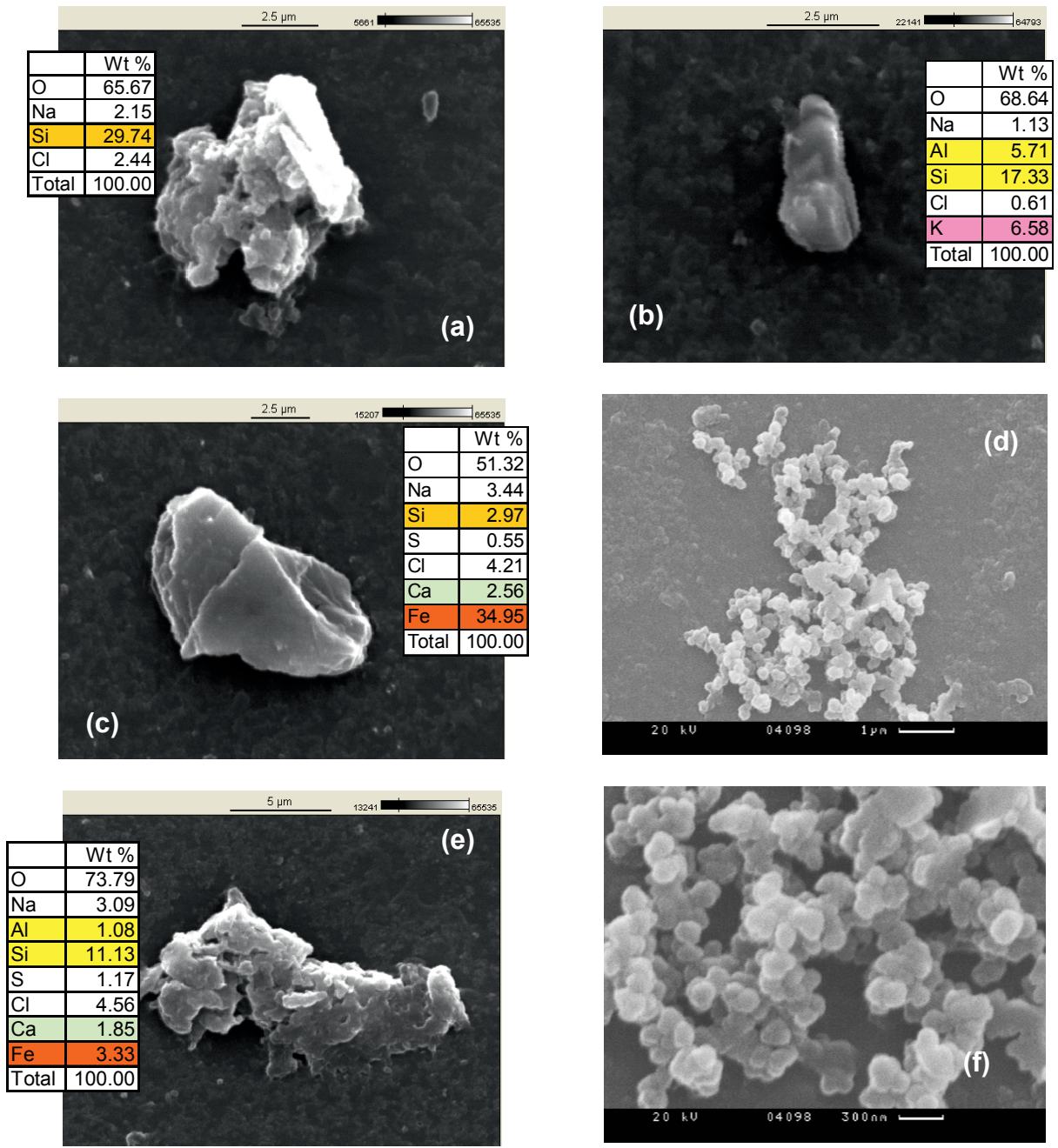

Fig. 8: SEM images of groundwater KLX17A (416 – 437.51) m colloids on a 50 nm track-etched Polycarbonate filter

Comparison with Äspö and Forsmark data

In the Äspö colloid project ⁶ a series of boreholes along the access tunnel have been sampled and their groundwater was directly analyzed with the mobile LIBD system. A correlation was drawn (Fig. 9) between the colloid concentration and the Cl⁻ concentration of the groundwater. At a Cl⁻ concentration of about 4000 mg/l a remarkable decrease of the colloid concentration over 4 orders of magnitude down to the LIBD detection limit of about 10 ng/l was observed.

The Forsmark KFM sample data from 307 m to 390 m sampling depth fits quite well into this correlation. According to the colloid concentration correlation with groundwater salinity we should expect lower colloid concentrations for samples KFM01D, KFM08A, and KFM08D from the deeper sampling depths 442 m, 590 m, and 663 m (Fig. 9). Possible reasons for the somewhat high particle concentrations have been discussed in previous Forsmark reports.

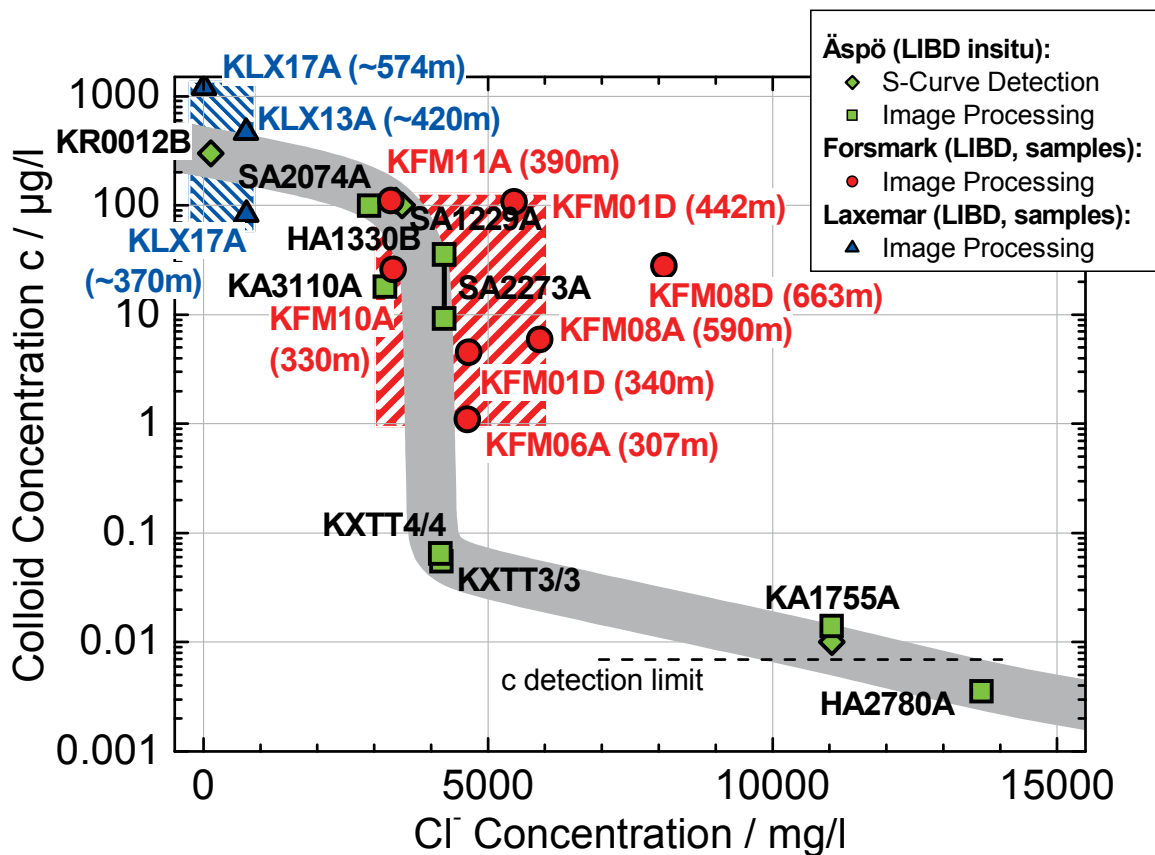
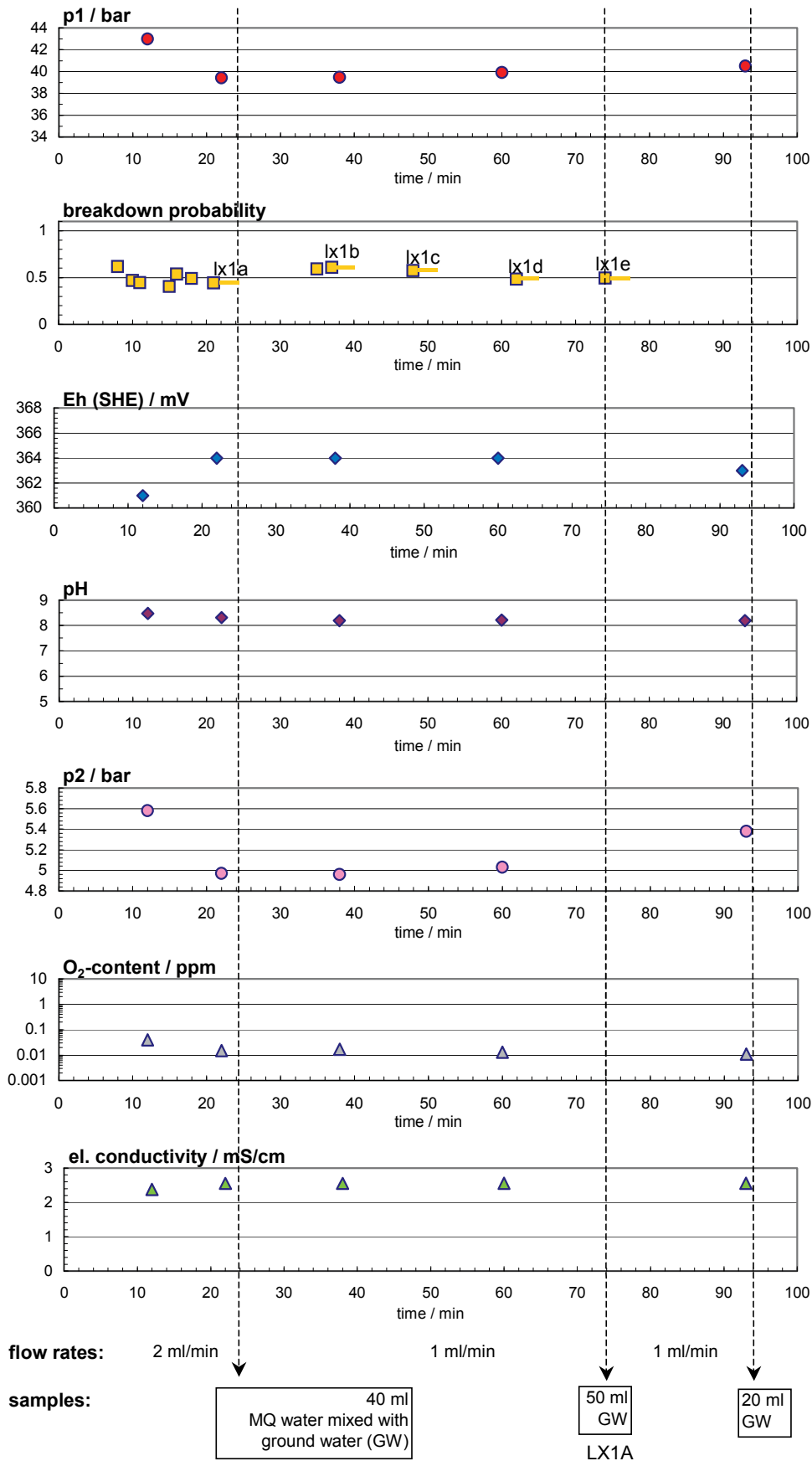

Fig. 9: Correlation between colloid concentration and chloride concentration in different groundwater from Äspö ^{2, 6} and in Forsmark samples.
(): sampling depths

References

- ¹ W. Hauser, H. Geckeis, J.I. Kim, Th. Fierz, A mobile laser-induced breakdown detection system and its application for the in situ-monitoring of colloid migration, *Coll. Surf.* 203, 2002, 37-45
- ² W. Hauser, H. Geckeis, R. Götz, In situ determination of natural groundwater colloids in granite shear zones along the Äspö HRL Tunnel by LIBD, 27th Int. conf. on Scientific Basis for Nuclear Waste Management, Kalmar, S, June 15- 18, 2003
- ³ Geckeis, H., Schäfer, T., Rabung, T., Hauser, W., Möri, A., Missana, T., Eikenberg, J., Degueldre, C., Fierz, T., Alexander, W.R., Inorganic colloid borne actinide migration studied under in-situ conditions at the Grimsel test site, 9th Int. conf. on Chemistry and Migration Behavior of Actinides and Fission Products in the Geosphere, Migration '03, Gyeongju, Korea, Sept. 21- 26, 2003
- ⁴ J. Källgarden, P. Andersson, M. Holmqvist, Äspö HRL, TRUE-1 continuation project, History and current status on flow, pressure, water chemistry and installations at the TRUE-1 site, SKB International Progress Report IPR-02-46, Stockholm, S, 2001
- ⁵ Cornell, R.M. and Schwertmann, U., 1996. The Iron Oxides -structure, properties, reactions, occurrence and uses-. VCH-Verlag, Weinheim, 573 pp.
- ⁶ Hauser, W., Götz, R., Geckeis, H., Kienzler, B., In-situ colloid detection in granite groundwater along the Äspö Hard Rock Laboratory access tunnel, In Laaksoharju, M., Äspö Hard Rock Laboratory, Status report of the Colloid investigation conducted at the Äspö HRL during the years 2000-2003, SKB International Progress Report IPR-03-38, Stockholm, S, 2003

Logged raw data from elution of sampling container SKB PVB 203 (KLX13A (432-439.16m))



Logged raw data from elution of sampling container SKB PVB 025 (KLX13A (432-439.16m))

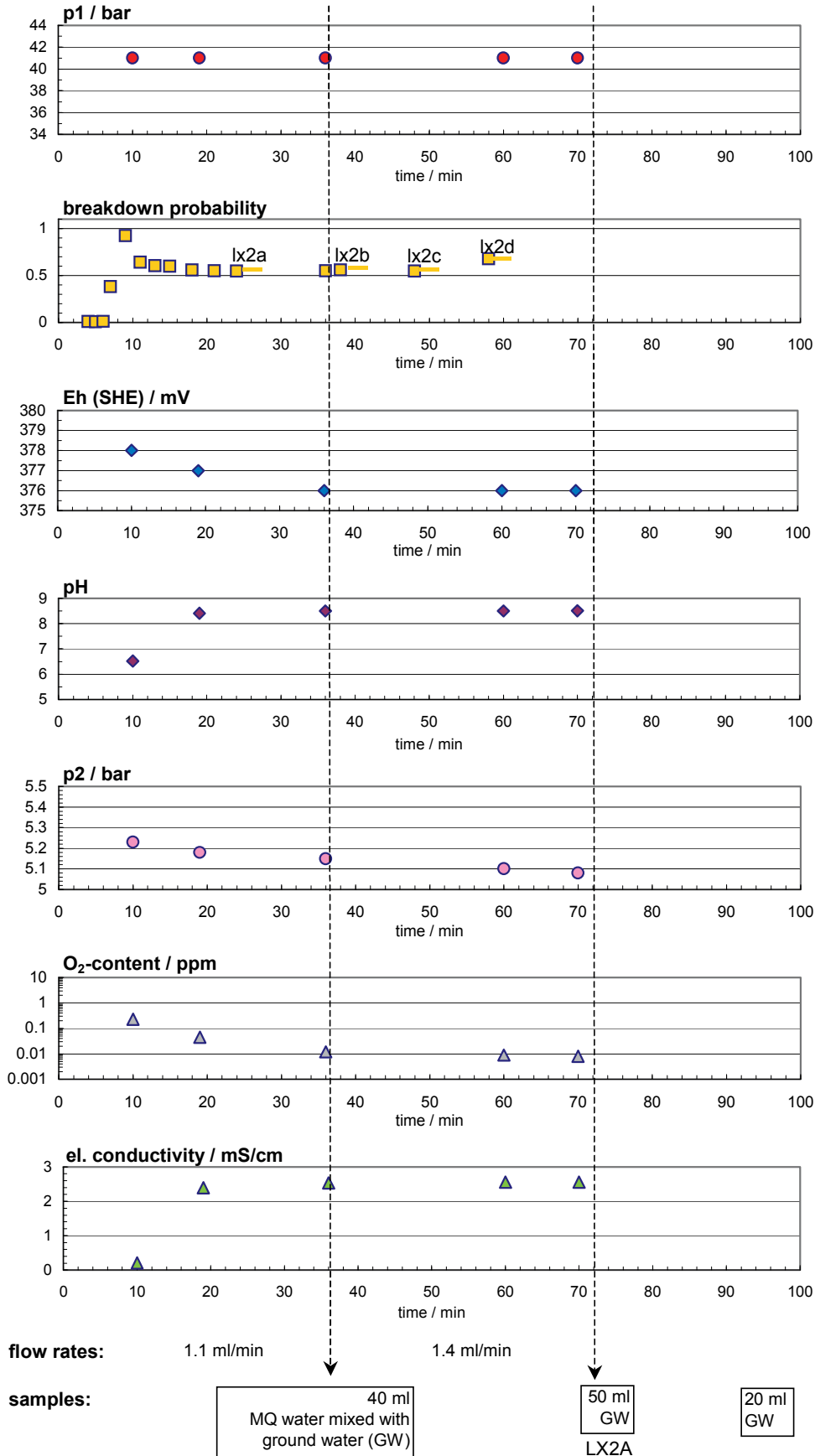

Logged raw data from elution of sampling container SKB PVB 201 (KLX17A (642-701m))

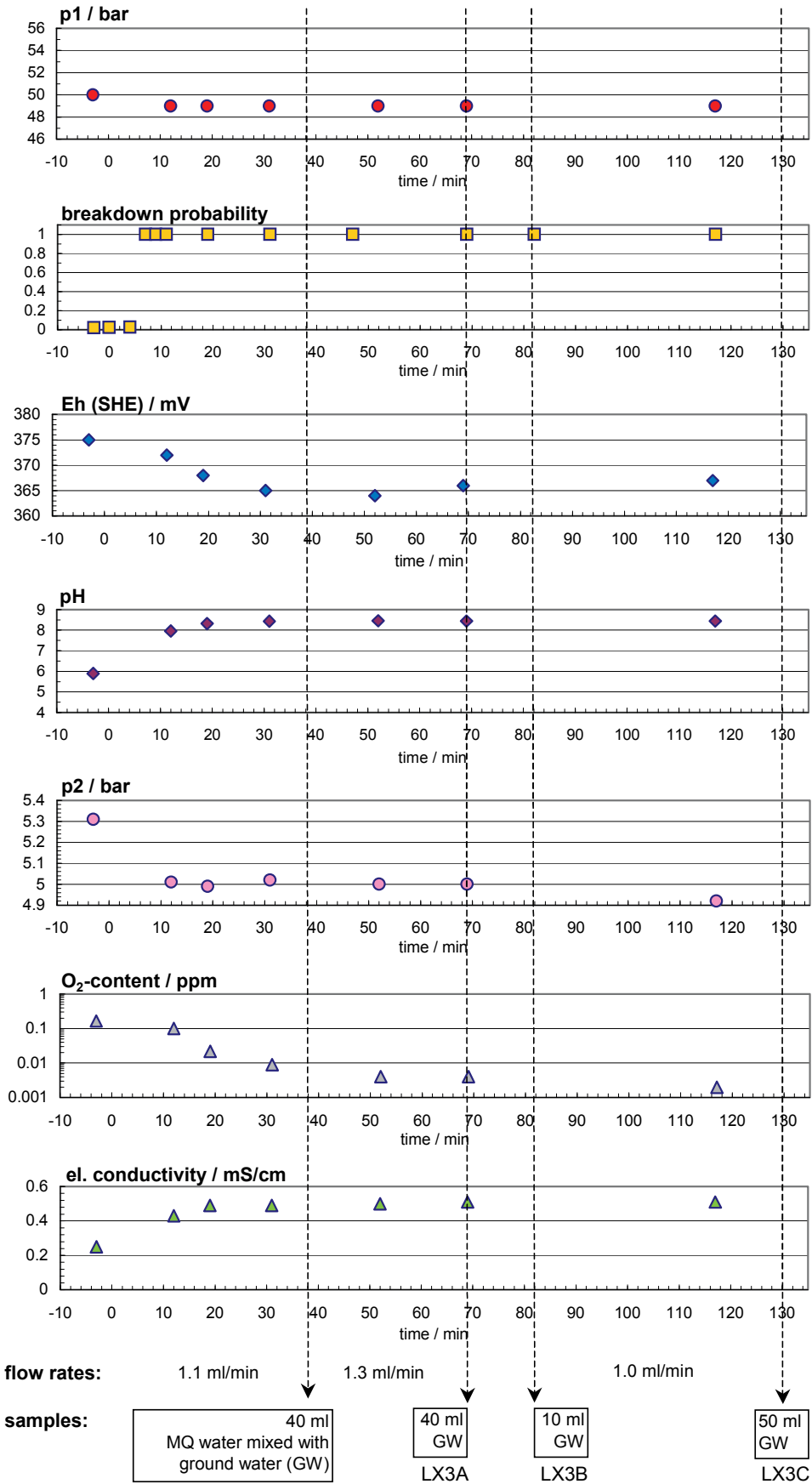

Logged raw data from elution of sampling container SKB PVB 9506-1 (KLX17A (642-701m))

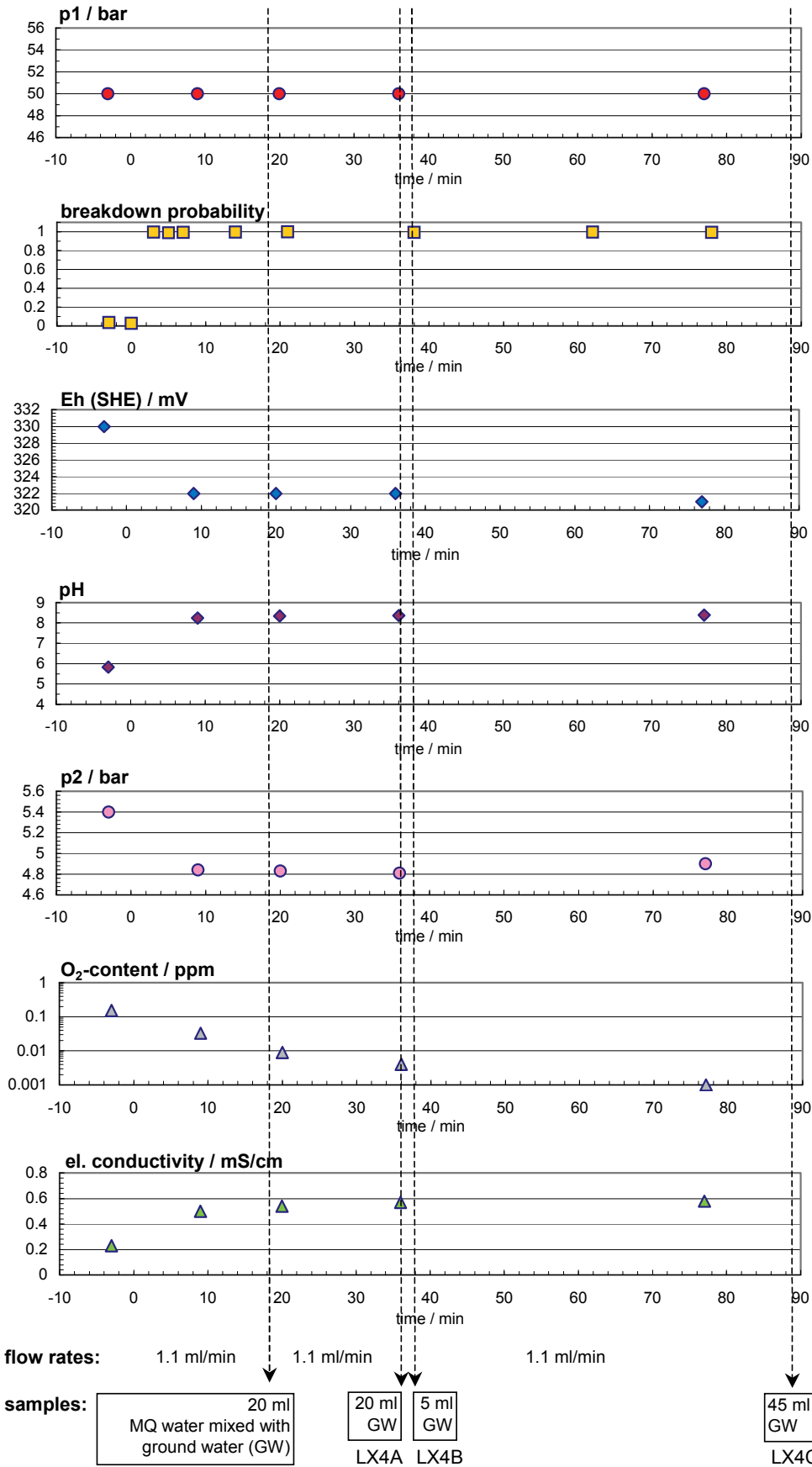

Logged raw data from elution of sampling container SKB PVB 024 (KLX17A (416-437.51m))

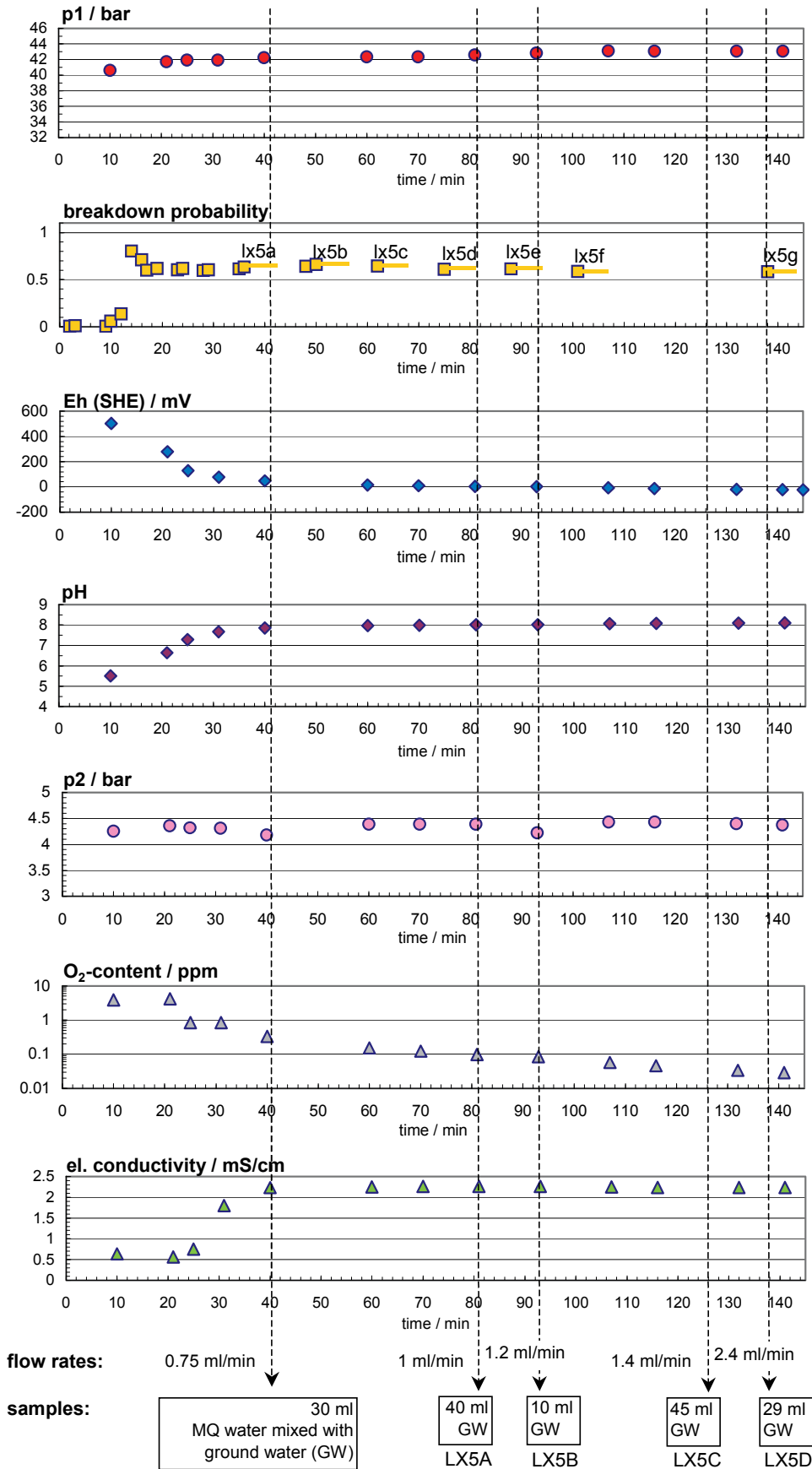

Logged raw data from elution of sampling container SKB PVB 9506-4 (KLX17A (416-437.51m))

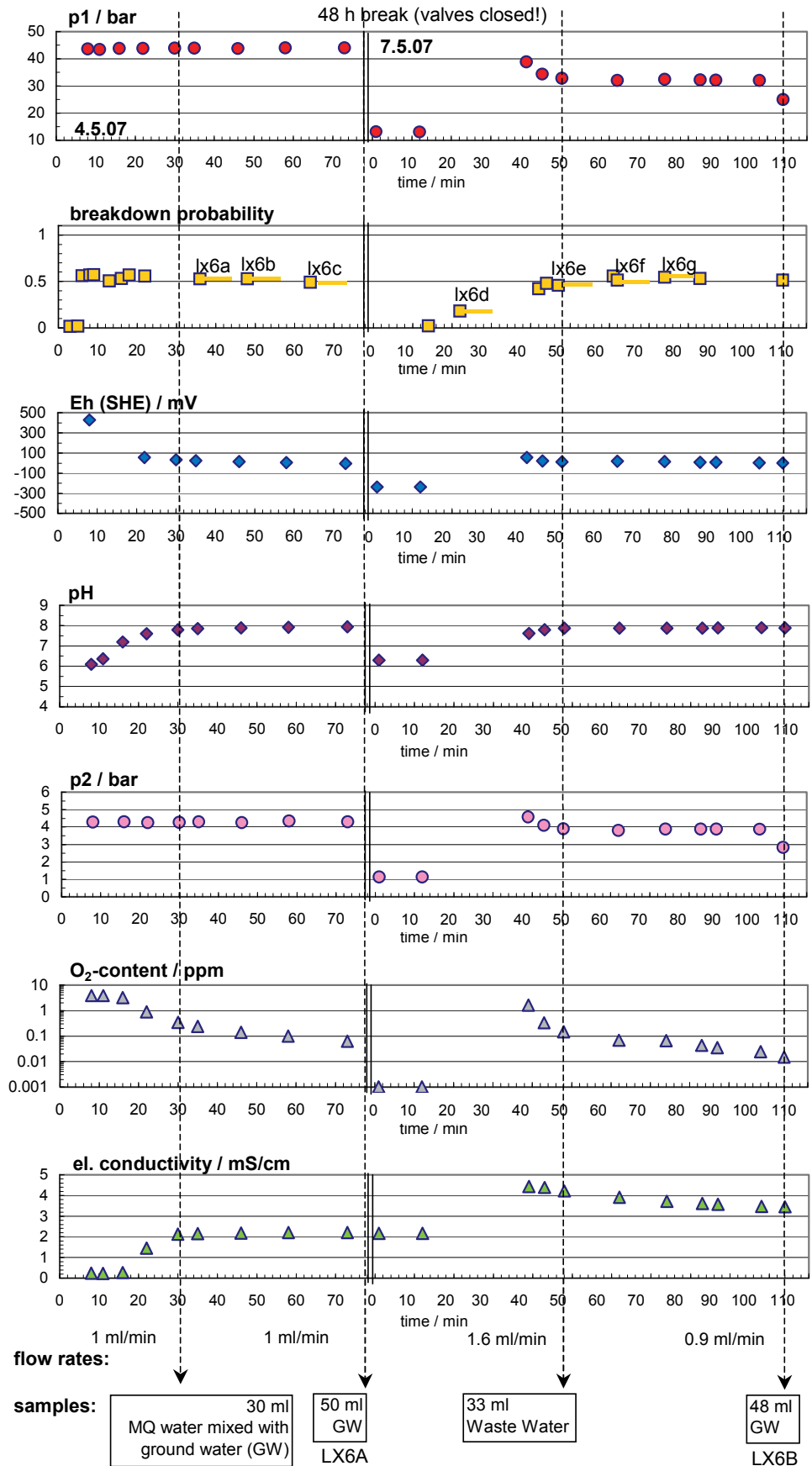

Appendix 9

Sampling and analysis methods

Table A9-1. Sample handling routines and analysis methods

| Component group | Component/ element | Sample container (material) | Volume (mL) | Filtering | Preparation/ Conservation* | Analysis method | Analysis within - or delivery time to lab. |
|------------------------------|---|-----------------------------|----------------|---|--------------------------------|---|---|
| Drill water | Uranine | Glass (brown) | 100 | No | No | Spectrofluorometry | – |
| Anions | HCO ₃ ⁻ pH (lab) cond. (lab) | Plastic | 250 | No | No | Titration Pot. meas, Cond. meas. | The same day – maximum 24 hours |
| | Cl ⁻ , SO ₄ ²⁻ , Br ⁻ , F ⁻ | Plastic | 250 | Yes (in connection to the analysis) | No | Titration (Cl ⁻) IC (Cl ⁻ , SO ₄ ²⁻ , Br ⁻ , F ⁻) ISE (F ⁻) | Not critical (month) |
| | Br ⁻ (control sample to external laboratory) | Plastic | 100 | Yes | No | ICP MS | Not critical (month) |
| | I ⁻ | Plastic | 100 | Yes | No | ICP MS | Not critical (month) |
| Cations etc. | Na, K, Ca, Mg, S(tot), Si(tot), Fe, Mn, Li, Sr | Plastic (acid washed) | 100 | Yes | Yes (1 mL HNQ) | ICP AES ICP MS | Not critical (month) |
| Fe(II), Fe(tot) | Fe(II), Fe(tot) | Plastic-PEH(acid washed) | 500 | Yes | Yes (5 mL HCl) | Spectrophotometry Ferrozine method | As soon as possible the same day |
| Hydrogen sulphide | HS ⁻ | Glass (Winkler) | About 120×2 | Yes | 1 mL 1 M NaOH+ 1 mL 1M ZnAc | Spectrophotometry | Immediately or if conserved, a few days |
| Nutrient salts | NO ₂ -N, NO ₃ -N+NO ₂ -N, PO ₄ -P | Plastic | 250 | Yes | No | Spectrophotometry | Maximum 24 hours |
| | NH ₄ -N | Plastic cylinder | 50 | No | No | Spectrophotometry | Maximum 24 hours |
| Environmental metals etc. | Al, As, Ba, B, Cd, Co, Cr, Cu, Hg, Mo, Ni, P, Pb, V, Zn, In | Plastic | 100 | Yes | Yes (1 mL HNO ₃) | ICP AES ICP MS | Not critical (month) |
| Lanthanoids, U, Th, etc. | Sc, Rb, Y, Zr, I, Sb, Cs, La, Hf, Tl, Ce, Pr, Nd, Sm, Eu, Gd, Tb, Dy, Ho, Er, Tm, Yb, Lu, U, Th | Plastic | 100 | Yes | Yes (1 mL HNO ₃) | ICP AES ICP MS | Not critical (month) |

Appendix 9

Sampling and analysis methods

| Component group | Component/ element | Sample container (material) | Volume (mL) | Filtering | Preparation/ Conservation* | Analysis method | Analysis within - or delivery time to lab. |
|---|---|-----------------------------|-------------|-----------|-------------------------------------|---|--|
| Dissolved organic Carbon | DOC | Plastic | 250 | Yes | Frozen, transported in isolated bag | UV oxidation, IR Carbon analyzer Shimadzu TOC5000 | Short transportation time |
| Total organic Carbon | TOC | Plastic | 250 | No | Frozen, transported in isolated bag | UV oxidation, IR Carbon analyzer Shimadzu TOC5000 | Short transportation time |
| Environmental isotopes | $\delta^2\text{H}$, $\delta^{18}\text{O}$ | Plastic | 100 | No | – | MS | Not critical (month) |
| Tritium, | ^3H (enhanced.) | Plastic (dry bottle) | 500 | No | – | LSC | Not critical (month) |
| Chlorine-37 | $\delta^{37}\text{Cl}$ | Plastic | 500 | No | – | ICP MS | Not critical (month) |
| Carbon isotopes | $\delta^{13}\text{C}$, pmC (^4C) | Glass(brown) | 100×2 | No | – | (A)MS | A few days |
| Sulphur isotopes | $\delta^{34}\text{S}$ | Plastic | 1000 | No | – | Combustion, ICP MS | No limit |
| Strontium-isotopes | $^{87}\text{Sr}/^{86}\text{Sr}$ | Plastic | 100 | No | – | TIMS | Days or Week |
| Uranium and Thorium isotopes | ^{234}U , ^{235}U , ^{238}U , ^{232}Th , ^{230}Th , | Plastic | 1000 | No | – | Chemical separat. Alfa/gamma spectrometry | No limit |
| Boron isotopes | $^{10}\text{B}/^{11}\text{B}$ | Plastic | 100 | Yes | Yes (1 mL HNO_3) | ICP MS | No limit |
| Radon and Radium isotopes | ^{222}Rn , ^{226}Ra | Plastic | 1000 | No | No | EDA, RD-200 | Immediate transport |
| Dissolved gas (content and composition) | Ar, He, N_2 , CO_2 , O_2 , CH_4 , H_2 , CO , C_2H_6 , C_2H_4 , C_2H_2 , C_3H_8 , C_3H_6 | Cylinder of stainless steel | 200 | No | No | GC | Immediate transport |

Sampling and analysis methods

| Component group | Component/ element | Sample container (material) | Volume (mL) | Filtering | Preparation/ Conservation* | Analysis method | Analysis within - or delivery time to lab. |
|------------------------------|--|-----------------------------|--------------------------|-----------|----------------------------|-------------------|--|
| Colloids | Filter series and fractionation (Analysis of cations and environmental metals) | Polycarbonate filters | 2.0, 0.4, 0.2 and 0.05µm | – | Ar atmosphere | ICP AES ICP MS | Immediate transport |
| Density | Density | Plastic | 250 | No | – | Pycnometer | – |
| Archive samples with acid | – | Plastic (washed in acid) | 100×2 ** | Yes | Yes (1 mL HNQ) | – | Storage in freeze container |
| Archive samples without acid | – | Plastic | 250×2 ** | Yes | No | – | Storage in freeze container |

* Suprapur acid is used for conservation of samples

** Minimum number, the number of archive samples can vary depending on how many similar samples collected at the same occasion.

Abbreviations and definitions:

| | |
|---------|---|
| IC | Ion chromatograph |
| ISE | Ion selective electrode |
| ICP AES | Inductively Coupled Plasma Atomic Emission Spectrometry |
| ICP MS | Inductively Coupled Plasma Mass Spectrometry |
| INAA | Instrumental Neutron Activation Analysis |
| MS | Mass Spectrometry |
| LSC | Liquid Scintillation Counting |
| (A)MS | (Accelerator) Mass Spectrometry |
| TIMS | Thermal Ionization Mass Spectrometry |
| GC | Gas Chromatography |

Sampling and analysis methods

Table A9-2. Reporting limits and measurement uncertainties

| Component | Method | Detection limit | Reporting limit or | Unit | Measurement uncertainties ² | "Total" uncertainty ³ |
|-------------------------------|----------------------|-----------------|----------------------------|------|--|----------------------------------|
| HCO ₃ ⁻ | Alkalinity titration | 0.2 | 1 | mg/L | 4 % | <10 % |
| pH | Pot. Meas. | – | – | – | 5% | – |
| Cond. | Cond. Meas. | 0.02 | 1 | mS/m | 4% | – |
| Cl ⁻ | Mohr titration | 5 | 70 | mg/L | 5 % | <10 % |
| Cl ⁻ | IC | 0.2 | 0.5 | | 6 % | 10 % |
| SO ₄ ²⁻ | IC | 0.2 | 0.5 | mg/L | 6 % | 15 % |
| Br ⁻ | IC | 0.2 | 0.7 | mg/L | 9 % | 20 % |
| Br ⁻ | ICP | – | 0.001 – 0.010 ¹ | | 15 % | |
| F ⁻ | IC | 0.2 | 0.6 | mg/L | 10 % | 20 % |
| F ⁻ | ISE | – | – | | – | – |
| I ⁻ | ICP | – | 0.001 – 0.010 ¹ | mg/L | 15 % | 20 % |
| Na | ICP | – | 0.1 | mg/L | 4 % | 10 % |
| K | ICP | – | 0.4 | mg/L | 6 % | 15 % |
| Ca | ICP | – | 0.1 | mg/L | 4 % | 10 % |
| Mg | ICP | – | 0.09 | mg/L | 4 % | 10 % |
| S(tot) | ICP | – | 0.160 | mg/L | 10 % | 15 % |
| Si(tot) | ICP | – | 0.03 | mg/L | 4 % | 15 % |
| Sr | ICP | – | 0.002 | mg/L | 4 % | 15 % |
| Li | ICP | – | 0.2 - 2 ¹ | µg/L | 10 % | 20 % |
| Fe | ICP | – | 0.4-4 ¹ | µg/L | 6 % | 10 % |
| Mn | ICP | – | 0.03-0.1 | µg/L | 8 % | 10 % |

Sampling and analysis methods

| Component | Method | Detection limit | Reporting limit or | Unit | Measurement uncertainties ² | "Total" uncertainty ³ |
|---|------------------------|-----------------|--------------------|------|--|--|
| Fe(II), Fe(tot) | Spectro- photometry | 5 | 20 | µg/L | 15 % (>30 µg/L) | 20 % |
| HS ⁻ | Spectro- photometry | 2 | 30-200 200-500 | µg/L | 18 % 30 µg/L | 20 % |
| NO ₂ -N | Spectro- photometry | – | 0.1-20 >20 | µg/L | 0.1 µg/L 2 % | 15 % |
| NO ₂ -N +NO ₃ -N | Spectro- photometry | – | 0.2-20 >20 | µg/L | 0.2 µg/L 2.5 % | 15 % |
| NH ₄ -N | Spectro- photometry | – | 0.5-20 >20 | µg/L | 0.5 µg/L 2.4 % | 15 % |
| PO ₄ -P | Spectro- photometry | – | 0,5-20 >20 | µg/L | 0.4 µg/L 2.2 % | 15 % |
| Al, Zn | ICP | – | 0.2-0.7 | µg/L | 12 % | 20 % |
| Ba, Cr, Mo Pb | ICP | – | 0.01-0.3 | µg/L | 7-10 % | 20 % |
| Cd, Hg | ICP | – | 0.002-0.5 | µg/L | 5-9 % | 20 % |
| Co, V | ICP | – | 0.005-0.05 | µg/L | 5-8 % | 20 % |
| Cu | ICP | – | 0.1-0.5 | µg/L | 8 % | 20 % |
| Ni | ICP | – | 0.05-0.5 | µg/L | 8% | 20 % |
| P | ICP | – | 1-40 | µg/L | 6 % | 15 % |
| As | ICP | – | 0.01-0.5 | µg/L | 20 % | Within the same size (low conc.) |
| La, Ce, Pr, Nd, Sm, Eu, Gd, Tb, Dy, Ho, Er, Tm, Yb, Y, Hf | ICP | – | 0.005-0.05 | µg/L | 10 % | Within the same size (low conc.) |
| Sc, In, Th | ICP | – | 0.05-0.5 | µg/L | 10 % | Within the same size (low conc.) |

Sampling and analysis methods

| Component | Method | Detection limit | Reporting limit or range | Unit | Measurement uncertainties ² | "Total" uncertainty ³ |
|--|----------------|-----------------|--------------------------|-------------------------------|--|----------------------------------|
| Rb, Zr, Sb, Cs, Tl | ICP | – | 0.025-0.25 | µg/L | 10 % | Within the same size (low conc.) |
| U | ICP | – | 0.001-0.01 | µg/L | 12 % | Within the same size (low conc.) |
| DOC | See Tab. A10-1 | – | 0.5 | mg/L | 8 % | 30 % |
| TOC | See Tab. A10-1 | – | 0.5 | mg/L | 10 % | 30 % |
| δ ² H | MS | – | 2 | ‰ SMOW ⁴ | 1.0 ‰ | – |
| δ ¹⁸ O | MS | – | 0.1 | ‰ SMOW ⁴ | 0.2 ‰ | – |
| ³ H | LSC | – | 0.8 or 0.1 | TU ⁵ | 0.8 or 0.1 TU | – |
| δ ³⁷ Cl | ICP MS | – | 0.2 ‰ (20 mg/L) | ‰ SMOC ⁶ | – | – |
| δ ¹³ C | A (MS) | – | >20 mg carbon | ‰ PDB ⁷ | – | – |
| pmC (¹⁴ C) | A (MS) | – | >20 mg carbon | pmC ⁸ | – | – |
| δ ³⁴ S | ICP MS | – | 0.2 ‰ | ‰ CDT ⁹ | 0.2 ‰ | – |
| ⁸⁷ Sr/ ⁸⁶ Sr | MS | – | – | No unit (ratio) ¹⁰ | 0.000020 | – |
| ¹⁰ B/ ¹¹ B | ICP MS | – | – | No unit (ratio) ¹⁰ | 0.0020 | – |
| ²³⁴ U, ²³⁵ U, ²³⁸ U, ²³² Th, ²³⁰ Th | Alfa spectr. | – | 0.05 | Bq/L ¹³ | 0.05 Bq/L | Right order of magnitude |
| ²²² Rn, ²²⁶ Ra | LSC | – | 0.1 | Bq/L | 0.05 Bq/L | |

1. Reporting limits at salinity ≤ 0.4 ‰ (520 mS/m) and ≤ 3.5 ‰ (3810 mS/m) respectively.
2. Measurement uncertainty reported by consulted laboratory, generally 95 % confidence interval.
3. Estimated total uncertainty by experience (includes effects of sampling and sample handling).

Sampling and analysis methods

4. Per mill deviation¹¹ from SMOW (Standard Mean Ocean ic Water).
5. TU=Tritium Units, where one TU corresponds to a Tritium/hydrogen ratio of 10^{-18} (1 Bq/L Tritium = 8.45 TU).
6. Per mill deviation¹¹ from SMOC (Standard Mean Oceanic Chloride).
7. Per mill deviation¹¹ from PDB (the standard PeeDee Belemnite).
8. The following relation is valid between pmC (percent modern carbon) and Carbon-¹⁴ age: $pmC = 100 \times e^{((1950-y-1.031)/8274)}$
where y = the year of the C-14 measurement and t = C-14 age
9. Per mill deviation¹² from CDT (the standard Canyon Diablo Troilite).
10. Isotope ratio without unit.
11. The following expressions are applicable to convert activity to concentration, for uranium-238 and thorium-232:
1 ppm U = 12.4 Bq/kg²³⁸U
1 ppm Th = 3.93 Bq/kg²³²Th
12. Isotopes are often reported as per mill deviation from a standard. The deviation is calculated as:
 $\delta Y_l = 1000 \times (K_{\text{sample}} - K_{\text{standard}}) / K_{\text{standard}}$ where K= the isotope ratio and y l =²H, ¹⁸O, ³⁷Cl, ¹³C or ³⁴S etc.

Table A10-1. Water Composition

| Idcode | Secup m | Seclow m | Sample no. | Sampling date | Charge Bal % | Na mg/L | K mg/L | Ca mg/L | Mg mg/L | HCO ₃ ⁻ mg/L | Cl ⁻ mg/L | SO ₄ ²⁻ mg/L | SO ₄ -S mg/L | Br ⁻ mg/l | F ⁻ mg/L | Si mg/L | Fe mg/L | Fe-tot mg/L | Fe(II) mg/L |
|--------|------------|-------------|---------------|------------------|-----------------|------------|-----------|------------|------------|---------------------------------------|-------------------------|---------------------------------------|----------------------------|-------------------------|------------------------|------------|------------|----------------|----------------|
| KLX13A | 432.00 | 439.16 | 11545 | 2006-12-14 | - | - | - | - | - | 75.3 | 734 | - | - | - | - | - | - | - | - |
| KLX13A | 432.00 | 439.16 | 11546 | 2006-12-18 | -0.86 | 464 | 1.94 | 55.1 | 3.36 | 70.5 | 761.7 | 37.3 | 13.0 | 3.875 | 3.6 | 6.67 | 0.0017 | 0.006 | < 0.006 |
| KLX13A | 432.00 | 439.16 | 11547 | 2006-12-21 | 3.02 | 501 | 1.93 | 59.5 | 3.53 | 71.8 | 758.8 | 37.85 | 13.8 | 3.775 | 3.28 | 7.1 | 0.0017 | < 0.006 | < 0.006 |
| KLX13A | 432.00 | 439.16 | 11549 | 2007-01-02 | - | - | - | - | - | - | - | - | - | - | - | - | - | - | - |
| KLX13A | 432.00 | 439.16 | 11550 | 2007-01-04 | 0.13 | 467 | 2.00 | 53.5 | 3.18 | 74.1 | 745.2 | 36.47 | 13.0 | 3.425 | 3.63 | 6.81 | 0.0061 | 0.011 | < 0.006 |
| KLX13A | 432.00 | 439.16 | 11606 | 2007-01-08 | -0.79 | 458 | 1.83 | 52.1 | 3.14 | 73.7 | 744.4 | 36.53 | 12.8 | 3.52 | 3.63 | 6.64 | 0.0022 | < 0.006 | < 0.006 |
| KLX13A | 432.00 | 439.16 | 11607 | 2007-01-11 | -1.68 | 449 | 1.79 | 52.0 | 3.09 | 73.9 | 744 | 36.75 | 12.6 | 3.475 | 3.85 | 6.5 | 0.0024 | < 0.006 | < 0.006 |
| KLX13A | 432.00 | 439.16 | 11608 | 2007-01-16 | - | - | - | - | - | - | - | - | - | - | - | - | - | - | - |
| KLX13A | 432.00 | 439.16 | 11609 | 2007-01-17 | -0.85 | 449 | 1.75 | 51.0 | 3.01 | 75.3 | 728.2 | 37.05 | 12.4 | 3.65 | 3.75 | 6.56 | 0.0022 | 0.006 | < 0.006 |
| KLX13A | 432.00 | 439.16 | 11610 | 2007-01-17 | - | - | - | - | - | 75.4 | 735.3 | 35.0 | - | 3.502 | 3.62 | - | - | < 0.006 | < 0.006 |
| KLX13A | 432.00 | 439.16 | 11611 | 2007-01-21 | 0.33 | 463 | 1.76 | 52.3 | 3.22 | 74.6 | 733.4 | 35.88 | 12.9 | 3.6 | 3.73 | 7.2 | 0.383 | 0.324 | 0.089 |
| KLX13A | 499.50 | 506.66 | 11536 | 2006-11-21 | - | - | - | - | - | 176.00 | 274.4 | - | - | - | - | - | - | - | - |
| KLX13A | 499.50 | 506.66 | 11537 | 2006-11-23 | -0.07 | 413 | 2.65 | 65.5 | 5.5 | 97.7 | 677.5 | 43.28 | 15.0 | 3.55 | 3.23 | 6.99 | 1.52 | 1.434 | 1.412 |
| KLX13A | 499.50 | 506.66 | 11538 | 2006-11-27 | - | - | - | - | - | - | - | - | - | - | - | - | - | - | - |
| KLX13A | 499.50 | 506.66 | 11541 | 2006-11-28 | -0.47 | 469 | 2.3 | 66.3 | 4.71 | 81.8 | 774.1 | 47.08 | 16.4 | 4.35 | 3.45 | 6.7 | 0.219 | 0.212 | 0.198 |
| KLX13A | 499.50 | 506.66 | 11542 | 2006-11-30 | -1.55 | 458 | 2.22 | 63.6 | 4.38 | 83.7 | 768.7 | 47.26 | 16.1 | 4.224 | 3.48 | 6.59 | 0.223 | 0.223 | 0.216 |
| KLX13A | 499.50 | 506.66 | 11543 | 2006-12-04 | - | - | - | - | - | - | - | - | - | - | - | - | - | - | - |
| KLX13A | 499.50 | 506.66 | 11544 | 2006-12-11 | -0.31 | 459 | 2.06 | 60.4 | 4.0 | 87.2 | 740.2 | 46.22 | 16.0 | 4.025 | 3.75 | 6.58 | 0.0303 | 0.045 | 0.044 |

- = Not analysed

< "value" = result less than detection limit

ChargeBal % = Rel. charge balance error %

SICADA: water_composition

Table A10-1. Water Composition

| Idcode | Secup m | Seclow m | Sample no. | Mn mg/L | Li mg/L | Sr mg/L | I ⁻ mg/L | pH | DOC mg/L | TOC mg/L | HS ⁻ mg/L | Drill water % | EICond mS/m |
|--------|------------|-------------|---------------|------------|------------|------------|------------------------|------|-------------|-------------|-------------------------|------------------|----------------|
| KLX13A | 432.00 | 439.16 | 11545 | - | - | - | - | 8.02 | - | - | - | 11.92 | 256.5 |
| KLX13A | 432.00 | 439.16 | 11546 | 0.0349 | 0.0723 | 1.21 | 0.0318 | 8.24 | 2.6 | - | < 0.006 | 11.31 | 263.2 |
| KLX13A | 432.00 | 439.16 | 11547 | 0.0337 | 0.0804 | 1.28 | 0.028 | 8.33 | 2.6 | - | < 0.006 | 11.36 | 263.3 |
| KLX13A | 432.00 | 439.16 | 11549 | - | - | - | - | - | - | - | - | 11.02 | - |
| KLX13A | 432.00 | 439.16 | 11550 | 0.0276 | 0.0718 | 1.21 | 0.0312 | 8.32 | 2.7 | 2.9 | < 0.006 | 10.96 | 258.3 |
| KLX13A | 432.00 | 439.16 | 11606 | 0.0275 | 0.0715 | 1.15 | 0.0256 | 8.39 | 2.6 | 2.7 | < 0.006 | 10.38 | 258.1 |
| KLX13A | 432.00 | 439.16 | 11607 | 0.0273 | 0.0716 | 1.16 | 0.025 | 8.35 | 2.7 | 2.8 | < 0.006 | 10.2 | 258.7 |
| KLX13A | 432.00 | 439.16 | 11608 | - | - | - | - | - | - | - | - | 10.66 | - |
| KLX13A | 432.00 | 439.16 | 11609 | 0.0271 | 0.071 | 1.13 | 0.031 | 8.33 | 2.7 | 2.9 | < 0.006 | 10.36 | 254.9 |
| KLX13A | 432.00 | 439.16 | 11610 | - | - | - | - | 8.37 | - | - | 0.006 | 10.33 | 262.7 |
| KLX13A | 432.00 | 439.16 | 11611 | 0.0318 | 0.073 | 1.18 | 0.0254 | 8.41 | 4.0 | 3.8 | < 0.006 | 8.75 | 257.1 |
| KLX13A | 499.50 | 506.66 | 11536 | - | - | - | - | 7.8 | - | - | - | 6.46 | 120.9 |
| KLX13A | 499.50 | 506.66 | 11537 | 0.182 | 0.0672 | 1.24 | 0.0468 | 7.82 | 4.1 | - | < 0.006 | 14.1 | 241.9 |
| KLX13A | 499.50 | 506.66 | 11538 | - | - | - | - | - | - | - | - | 16.22 | - |
| KLX13A | 499.50 | 506.66 | 11541 | 0.0648 | 0.0768 | 1.34 | 0.0464 | 8.04 | 2.6 | - | < 0.006 | 16.62 | 268.3 |
| KLX13A | 499.50 | 506.66 | 11542 | 0.0611 | 0.0753 | 1.31 | 0.041 | 8.07 | 2.6 | - | < 0.006 | 16.1 | 267.9 |
| KLX13A | 499.50 | 506.66 | 11543 | - | - | - | - | - | - | - | - | 16.4 | - |
| KLX13A | 499.50 | 506.66 | 11544 | 0.0519 | 0.076 | 1.23 | 0.0363 | 8.1 | 2.6 | - | < 0.006 | 15.92 | 261.2 |

- = Not analysed

< "value" = result less than detection limit

ChargeBal % = Rel. charge balance error %

SICADA: water_composition

Table A10-1. Water Composition

| Idcode | Secup m | Seclow m | Sample no. | NH ₄ -N mg/L | NO ₂ -N mg/L | NO ₃ -N mg/L | NO ₂ -N+NO ₃ -N mg/L | PO ₄ -P mg/L | P mg/L | Density g/mL |
|--------|------------|-------------|---------------|----------------------------|----------------------------|----------------------------|---|----------------------------|-----------|-----------------|
| KLX13A | 432.00 | 439.16 | 11545 | - | - | - | - | - | - | - |
| KLX13A | 432.00 | 439.16 | 11546 | 0.0198 | 0.0005 | < 0.0003 | 0.0006 | 0.0029 | - | - |
| KLX13A | 432.00 | 439.16 | 11547 | 0.0176 | < 0.0002 | < 0.0003 | < 0.0003 | 0.0021 | - | - |
| KLX13A | 432.00 | 439.16 | 11549 | - | - | - | - | - | - | - |
| KLX13A | 432.00 | 439.16 | 11550 | 0.0126 | < 0.0002 | < 0.0003 | < 0.0003 | 0.001 | 0.00194 | - |
| KLX13A | 432.00 | 439.16 | 11606 | 0.0166 | < 0.0002 | < 0.0003 | < 0.0003 | 0.0009 | 0.00167 | - |
| KLX13A | 432.00 | 439.16 | 11607 | 0.0134 | < 0.0002 | 0.0008 | 0.0008 | 0.0008 | 0.00157 | - |
| KLX13A | 432.00 | 439.16 | 11608 | - | - | - | - | - | - | - |
| KLX13A | 432.00 | 439.16 | 11609 | 0.0107 | 0.0006 | 0.001 | 0.0016 | 0.0009 | 0.00146 | 0.9981 |
| KLX13A | 432.00 | 439.16 | 11610 | 0.0081 | - | - | - | - | - | - |
| KLX13A | 432.00 | 439.16 | 11611 | 0.0275 | < 0.0002 | 0.0289 | 0.029 | 0.002 | 0.0204 | - |
| KLX13A | 499.50 | 506.66 | 11536 | - | - | - | - | - | - | - |
| KLX13A | 499.50 | 506.66 | 11537 | 0.1014 | < 0.0002 | 0.000518 | 0.000518 | 0.0014 | - | - |
| KLX13A | 499.50 | 506.66 | 11538 | - | - | - | - | - | - | - |
| KLX13A | 499.50 | 506.66 | 11541 | 0.0535 | < 0.0002 | 0.0004 | 0.000518 | 0.0038 | - | - |
| KLX13A | 499.50 | 506.66 | 11542 | 0.0475 | < 0.0002 | < 0.0003 | < 0.0003 | 0.0032 | - | - |
| KLX13A | 499.50 | 506.66 | 11543 | - | - | - | - | - | - | - |
| KLX13A | 499.50 | 506.66 | 11544 | 0.0394 | < 0.0002 | < 0.0003 | < 0.0003 | 0.0027 | - | - |

- = Not analysed

< "value" = result less than detection limit

ChargeBal % = Rel. charge balance error %

SICADA: water_composition

Table A10-2. Trace elements

| Idcode | Secup m | Seclow m | Sample no. | Sampling date | U µg/L | Th µg/L | As µg/L | Sc µg/L | Cd µg/L | Hg µg/L | V µg/L | Rb µg/L | Y µg/L | Zr µg/L | In µg/L | Cs µg/L | Ba µg/L |
|--------|------------|-------------|---------------|------------------|-----------|------------|------------|------------|------------|------------|-----------|------------|-----------|------------|------------|------------|------------|
| KLX13A | 432.00 | 439.16 | 11550 | 2007-01-04 | 0.0441 | < 0.02 | 0.14 | < 0.05 | 0.0087 | < 0.002 | 0.177 | 5.19 | 0.0234 | 0.0578 | < 0.05 | 0.512 | 95.5 |
| KLX13A | 432.00 | 439.16 | 11606 | 2007-01-08 | 0.047 | < 0.02 | 0.14 | < 0.05 | < 0.003 | < 0.002 | 0.145 | 4.86 | 0.0204 | < 0.03 | < 0.05 | 0.515 | 92.4 |
| KLX13A | 432.00 | 439.16 | 11607 | 2007-01-11 | 0.0459 | < 0.02 | 0.11 | < 0.05 | < 0.003 | < 0.002 | 0.166 | 5.40 | 0.0237 | < 0.03 | < 0.05 | 0.535 | 93.1 |
| KLX13A | 432.00 | 439.16 | 11609 | 2007-01-17 | 0.0447 | < 0.02 | 0.12 | < 0.05 | < 0.002 | < 0.002 | 0.155 | 5.21 | 0.022 | < 0.03 | < 0.05 | 0.526 | 92.1 |
| KLX13A | 432.00 | 439.16 | 11611 | 2007-01-21 | 0.0762 | 0.0222 | 0.14 | < 0.05 | < 0.006 | < 0.002 | 1.13 | 5.36 | 0.132 | 0.0776 | < 0.05 | 0.555 | 98.6 |

< "value" = result less than detection limit
 SICADA: trace_elements

Table A10-2. Trace elements

| Idcode | Secup m | Seclow m | Sample no. | La µg/L | Hf µg/L | Tl µg/L | Ce µg/L | Pr µg/L | Nd µg/L | Sm µg/L | Eu µg/L | Gd µg/L | Tb µg/L | Dy µg/L | Ho µg/L | Er µg/L | Tm µg/L |
|--------|------------|-------------|---------------|------------|------------|------------|------------|------------|------------|------------|------------|------------|------------|------------|------------|------------|------------|
| KLX13A | 432.00 | 439.16 | 11550 | 0.0069 | 0.0104 | < 0.005 | 0.0059 | < 0.005 | 0.0133 | < 0.005 | < 0.005 | < 0.005 | < 0.005 | < 0.005 | < 0.005 | < 0.005 | < 0.005 |
| KLX13A | 432.00 | 439.16 | 11606 | < 0.005 | < 0.005 | < 0.005 | < 0.005 | < 0.005 | < 0.005 | < 0.005 | < 0.005 | < 0.005 | < 0.005 | < 0.005 | < 0.005 | < 0.005 | < 0.005 |
| KLX13A | 432.00 | 439.16 | 11607 | < 0.005 | < 0.005 | < 0.005 | < 0.005 | < 0.005 | < 0.005 | < 0.005 | < 0.005 | < 0.005 | < 0.005 | < 0.005 | < 0.005 | < 0.005 | < 0.005 |
| KLX13A | 432.00 | 439.16 | 11609 | < 0.005 | < 0.005 | < 0.005 | < 0.005 | < 0.005 | < 0.005 | < 0.005 | < 0.005 | < 0.005 | < 0.005 | < 0.005 | < 0.005 | < 0.005 | < 0.005 |
| KLX13A | 432.00 | 439.16 | 11611 | 0.262 | < 0.005 | < 0.005 | 0.411 | 0.0464 | 0.191 | 0.0296 | < 0.005 | 0.0243 | < 0.005 | 0.0174 | < 0.005 | 0.0111 | < 0.005 |

< "value" = result less than detection limit
 SICADA: trace_elements

Table A10-2. Trace elements

| Idcode | Secup m | Seclow m | Sample no. | Yb μg/L | Lu μg/L |
|--------|------------|-------------|---------------|------------|------------|
| KLX13A | 432.00 | 439.16 | 11550 | < 0.005 | < 0.005 |
| KLX13A | 432.00 | 439.16 | 11606 | < 0.005 | < 0.005 |
| KLX13A | 432.00 | 439.16 | 11607 | < 0.005 | < 0.005 |
| KLX13A | 432.00 | 439.16 | 11609 | < 0.005 | < 0.005 |
| KLX13A | 432.00 | 439.16 | 11611 | 0.0103 | < 0.005 |

< "value" = result less than detection limit
 SICADA: trace_elements

| Idcode | Secup m | Seclow m | Sample no | Sampling date | $\delta^2\text{H}$ dev SMOW | ^3H TU | $\delta^{18}\text{O}$ dev SMOW | $^{10}\text{B}/^{11}\text{B}$ no unit | $\delta^{34}\text{S}$ dev CDT | $\delta^{13}\text{C}$ dev PDB | $^{87}\text{Sr}/^{86}\text{Sr}$ no unit | ^{14}C pmC | $\delta^{37}\text{Cl}$ dev SMOC |
|--------|------------|-------------|--------------|------------------|--------------------------------|--------------------|-----------------------------------|--|----------------------------------|----------------------------------|--|------------------------|------------------------------------|
| KLX13A | 432.00 | 439.16 | 11545 | 2006-12-14 | -117.8 | 4.8 | -15.6 | - | - | - | - | - | - |
| KLX13A | 432.00 | 439.16 | 11546 | 2006-12-18 | -119.9 | <0.8 | -15.7 | - | - | - | - | - | - |
| KLX13A | 432.00 | 439.16 | 11547 | 2006-12-21 | -119.5 | 3.2 | -15.8 | - | - | - | - | - | - |
| KLX13A | 432.00 | 439.16 | 11550 | 2007-01-04 | -120.3 | 4.0 | -15.7 | 0.2485 | 28.6 | x | 0.715226 | 29.07 | 0.3 |
| KLX13A | 432.00 | 439.16 | 11606 | 2007-01-08 | -119.3 | 3.1 | -15.8 | 0.249 | 28.6 | -13.7 | 0.715221 | 47.41 | -0.31 |
| KLX13A | 432.00 | 439.16 | 11607 | 2007-01-11 | -119.6 | 3.6 | -15.9 | 0.2451 | 29.0 | -16.56 | 0.715201 | 21.71 | -0.17 |
| KLX13A | 432.00 | 439.16 | 11609 | 2007-01-17 | -119.4 | 3.5 | -15.8 | 0.2437 | 28.5 | -15.83 | 0.715232 | 23.69 | -0.04 |
| KLX13A | 432.00 | 439.16 | 11611 | 2007-01-21 | -118.7 | 11.5 | -15.8 | 0.2421 | 29.1 | -17.11 | 0.715239 | 35.6 | 0.2 |
| KLX13A | 499.5 | 506.66 | 11536 | 2006-11-21 | -89 | 3.1 | -12.06 | - | - | - | - | - | - |
| KLX13A | 499.5 | 506.66 | 11537 | 2006-11-23 | -107.1 | 10.2 | -14.6 | - | - | - | - | - | - |
| KLX13A | 499.5 | 506.66 | 11541 | 2006-11-28 | -116.4 | 0.9 | -15.1 | - | - | - | - | - | - |
| KLX13A | 499.5 | 506.66 | 11542 | 2006-11-30 | -114 | 1.9 | -15.1 | - | - | - | - | - | - |
| KLX13A | 499.5 | 506.66 | 11544 | 2006-12-11 | -112.7 | 3.1 | -15.2 | - | - | * | - | - | * |

- = Not analysed

x = Not analysed due to analytical problems

A = Results will be reported later

* = Sample stored in freezer/refrigerator

< "value" = result less than detection limit

SICADA: isotopes_1_t

Table A10-4. Isotopes II (U-, Th, Ra- and Rn-isotopes)

| Idcode | Secup m | Seclow m | Sample no. | Sampling date | ²³⁸ U | ²³⁵ U | ²³⁴ U | ²³² Th | ²³⁰ Th | ²²⁶ Ra | ²²² Rn | ²²² Rn |
|--------|------------|-------------|---------------|------------------|------------------|------------------|------------------|-------------------|-------------------|-------------------|---------------------|-----------------------|
| | | | | | mBq/L | mBq/L | mBq/L | mBq/L | mBq/L | Bq/L | Bq/L | Bq/L |
| | | | | | | | | | | | At time of analysis | At time of collection |
| KLX13A | 499.5 | 506.66 | 11544 | 2006-12-11 | * | * | * | * | * | 0.041 | 67.0 | 109 |
| KLX13A | 432.00 | 439.16 | 11550 | 2007-01-04 | 0.6 | < 0.02 | 3 | 0.1 | 0.3 | – | – | – |
| KLX13A | 432.00 | 439.16 | 11606 | 2007-01-08 | 0.7 | 0.2 | 2 | 0.1 | 0.1 | < 0.015 | 14.6 | 23.9 |
| KLX13A | 432.00 | 439.16 | 11607 | 2007-01-11 | 0.6 | < 0.02 | 3 | 0.1 | 0.3 | – | – | – |
| KLX13A | 432.00 | 439.16 | 11609 | 2007-01-17 | 0.8 | 0.1 | 3 | 0.4 | 1.2 | 0.016 | 10.4 | 17.3 |
| KLX13A | 432.00 | 439.16 | 11610 | 2007-01-17 | * | * | * | * | * | 0.01 | 10.4 | 17.8 |
| KLX13A | 432.00 | 439.16 | 11611 | 2007-01-21 | 1.3 | 0.1 | 5 | 0.5 | 0.7 | – | – | – |

- = Not analysed

A = Results will be reported later

* = Sample stored in freezer/refrigerator

< "value" = result less than detection limit

SICADA: u_th_isotope_t, ra_rn_isotope_t

Table A10-5. Dissolved gases

| Idcode | Secup m | Seclow m | Sample no. | Sampling date | Ar mL/L | He mL/L | N ₂ mL/L | CO ₂ mL/L | CH ₄ mL/L | O ₂ mL/L | H ₂ μL/L | CO μL/L | C ₂ H ₆ μL/L | C ₂ H ₄ μL/L | C ₂ H ₂ μL/L | C ₂ H ₂ _C ₂ H ₄ μL/L | C ₃ H ₈ μL/L | C ₃ H ₆ μL/L | DISS_GAS mL/L H ₂ O |
|--------|------------|-------------|---------------|------------------|------------|------------|------------------------|-------------------------|-------------------------|------------------------|------------------------|------------|---------------------------------------|---------------------------------------|---------------------------------------|--|---------------------------------------|---------------------------------------|-----------------------------------|
| KLX13A | 432.00 | 439.16 | 11609 | 2007-01-17 | 1.1 | 0.37 | 105 | 0.24 | 0.034 | 0.047 | < 3.2 | < 5.3 | 0.26 | 0.07 | < 0.05 | | < 0.11 | < 0.11 | 106 |

< "value" = result below detection limit
 SICADA: Dissolved_gases