

International
Progress Report

IPR-05-22

Äspö Hard Rock Laboratory

**Status Report
April – June 2005**

Svensk Kärnbränslehantering AB

October 2005

Svensk Kärnbränslehantering AB

Swedish Nuclear Fuel
and Waste Management Co
Box 5864
SE-102 40 Stockholm Sweden
Tel 08-459 84 00
+46 8 459 84 00
Fax 08-661 57 19
+46 8 661 57 19



**Äspö Hard Rock
Laboratory**

Report no.
IPR-05-22

Author
**Karin Pers
(comp.)**

Checked by

Approved
Anders Sjöland

No.
F50K
Date
October 2005

Date

Date
2005-11-01

Äspö Hard Rock Laboratory

Status Report April – June 2005

Svensk Kärnbränslehantering AB

October 2005

Keywords: Äspö HRL, Status Report

This report concerns a study which was conducted for SKB. The conclusions and viewpoints presented in the report are those of the author(s) and do not necessarily coincide with those of the client.

Overview

The Äspö Hard Rock Laboratory (HRL) constitutes an important part of SKB's work to design and construct a deep geological repository for spent nuclear fuel and to develop and test methods for characterisation of a suitable site.

The plans for SKB's research and development of technique during the period 2005–2010 are presented in SKB's RD&D-Programme 2004 /SKB, 2004/. The information given in the RD&D-Programme related to Äspö HRL is annually detailed in the Äspö HRL Planning Report /SKB, 2005/.

This Äspö HRL Status Report is a collection of the main achievements obtained during the second quarter 2005.

Technology

One of the goals for Äspö HRL is to demonstrate technology for and function of important parts of the repository system. This implies translation of current scientific knowledge and state-of-the-art technology into engineering practice applicable in a real repository. A number of large-scale field experiments are therefore conducted at Äspö HRL: Canister Retrieval Test, Prototype Repository, Backfill and Plug Test, Long Term Test of Buffer Material, Cleaning and sealing of investigation boreholes, KBS-3 method with horizontal emplacement, Large Scale Gas Injection Test, and Temperature Buffer Test. THM processes and gas migration in buffer material are addressed in the Task Force on Engineered Barrier Systems.

Geo-science

Geo-scientific research is a natural part of the activities at Äspö HRL. Studies with the major aims to increase the understanding of the rock mass properties and to increase the knowledge of measurements that can be used in site investigations are important activities: Geological mapping and modelling, Heat transport, Inflow predictions, Seismic influence on the groundwater system, Rock mechanic studies, and Äspö Pillar Stability Experiment.

Natural barriers

Many experiments in Äspö HRL are related to the rock, its properties, and *in situ* environmental conditions. The goals are to increase the scientific knowledge of the safety margins of the deep repository and to provide data for performance and safety assessment. The experiments performed at conditions expected to prevail at repository depth are: Tracer Retention Understanding Experiments (True Block Scale Continuation and True-1 Continuation), Long Term Diffusion Experiment, Radionuclide Retention Experiments, Colloid Project, Microbe Project, and Matrix Fluid Chemistry.

Tests of models for groundwater flow, radionuclide migration and chemical/biological processes are one main purpose of the Äspö HRL. The major project is the Äspö Task Force on Modelling of Groundwater Flow and Transport of Solutes.

Äspö facility

An important part of the work at the Äspö facility is the administration, operation, and maintenance of instruments as well as development of investigation methods. Other issues are to keep the stationary hydro monitoring system (HMS) continuously available and to carry out the programme for monitoring of groundwater head and flow and the programme for monitoring of groundwater chemistry.

The information and public relations group at Äspö HRL is responsible for presenting information about SKB and its facilities. They arrange visits to the facilities all year around as well as special events.

International co-operation

The Äspö HRL has so far attracted considerable international interest. Nine organisations from eight countries participate in the co-operation at Äspö HRL, apart from SKB, during 2005.

Environmental research

On the initiative of the Äspö Environmental Research Foundation the University of Kalmar has set up the Äspö Research School. The research school has a special interest in the transport of pollutants and their distribution in rock, groundwater, and biosphere. The research school is co-financed by the municipality of Oskarshamn, SKB, and the University of Kalmar.

Contents

1	General	4
2	Technology	5
2.1	Canister Retrieval Test	6
2.2	Prototype Repository	7
2.3	Backfill and Plug Test	8
2.4	Long Term Test of Buffer Material	10
2.5	Cleaning and sealing of investigation boreholes	12
2.6	KBS-3 method with horizontal emplacement	13
2.7	Large Scale Gas Injection Test	14
2.8	Temperature Buffer Test	15
2.9	In situ corrosion testing of miniature canisters	16
2.10	Rock Shear Experiment	16
2.11	Learning from experiences	17
2.12	Task Force on Engineered Barrier Systems	18
3	Geo-science	19
3.1	Geological mapping and modelling	19
3.2	Heat transport	20
3.3	Inflow predictions	20
3.4	Seismic influence on the groundwater system	22
3.5	Rock mechanics	22
3.6	Äspö Pillar Stability Experiment	23
4	Natural barriers	24
4.1	Tracer Retention Understanding Experiments	25
4.1.1	True Block Scale Continuation	25
4.1.2	True-1 Continuation	26
4.2	Long Term Diffusion Experiment	27
4.3	Radionuclide Retention Experiments	29
4.4	Colloid Project	30
4.5	Microbe Project	31
4.6	Matrix Fluid Chemistry	32
4.7	Task Force on Modelling of Groundwater Flow and Transport of Solutes	33
4.8	Padamot	35
4.9	Fe-oxides in fractures	36
5	Äspö facility	37
5.1	Facility operation	37
5.2	Hydro Monitoring System	38
5.3	Programme for monitoring of groundwater head and flow	39
5.4	Programme for monitoring of groundwater chemistry	40
5.5	Information and public relations	40
6	International co-operation	41
7	Environmental research	42
7.1	Äspö Research School	42
8	Documentation	43
8.1	Äspö International Progress Reports	43
8.2	Technical Documents and International Technical Documents	44
9	References	45

1 General

The Äspö Hard Rock Laboratory (HRL) constitutes an important part of SKB's work to design and construct a deep geological repository for spent nuclear fuel and to develop and test methods for characterisation of a suitable site.

One of the fundamental reasons behind SKB's decision to construct an underground laboratory was to create an opportunity for research, development and demonstration in a realistic and undisturbed rock environment down to repository depth. The underground part of the laboratory consists of a tunnel from the Simpevarp peninsula to the southern part of Äspö where the tunnel continues in a spiral down to a depth of 460 m. The rock volume and the available underground excavations have to be divided between all the experiments performed at the Äspö HRL. In Figure 1-1 the allocation of the experimental sites in Äspö HRL are shown.

The Äspö HRL and the associated research, development, and demonstration tasks, managed by the Repository Technology Department within SKB, have so far attracted considerable international interest.

SKB's overall plans for research, development, and demonstration during the period 2005–2010 are presented in SKB's RD&D-Programme 2004 /SKB, 2004/. The planned activities related to Äspö HRL are detailed on a yearly basis in the Äspö HRL Planning Report. The role of the Planning Report is also to present the background and objectives of each experiment and activity. This Status Report concentrates on the work in progress and refers to the Planning Report /SKB, 2005/ for more background information. The Annual Report will in detail present and summarise new findings and results obtained during the present year.

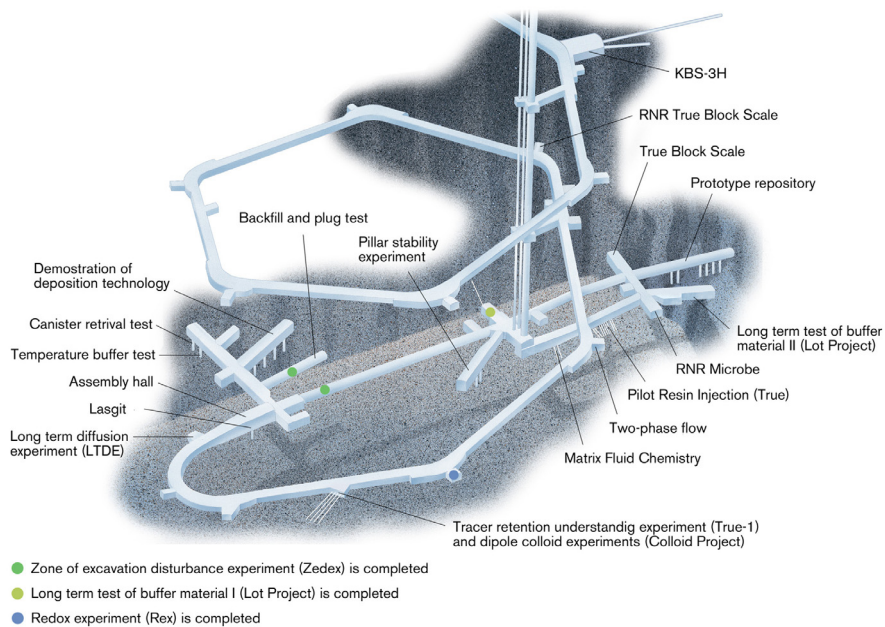

Figure 1-1 Allocation of experimental sites in Äspö HRL from -220 m to -450 m level.

2 Technology

One of the goals for Äspö HRL is to demonstrate technology for and function of important parts of the repository system. This implies translation of current scientific knowledge and state-of-the-art technology into engineering practice applicable in a real repository.

It is important that development, testing and demonstration of methods and procedures, as well as testing and demonstration of repository system performance, are conducted under realistic conditions and at appropriate scale. A number of large-scale field experiments and supporting activities are therefore conducted at Äspö HRL, see Figure 2-1. The experiments focus on different aspects of engineering technology and performance testing, and will together form a major experimental programme.



Figure 2-1 Boring of a horizontal deposition hole (KBS-3H).

2.1 Canister Retrieval Test

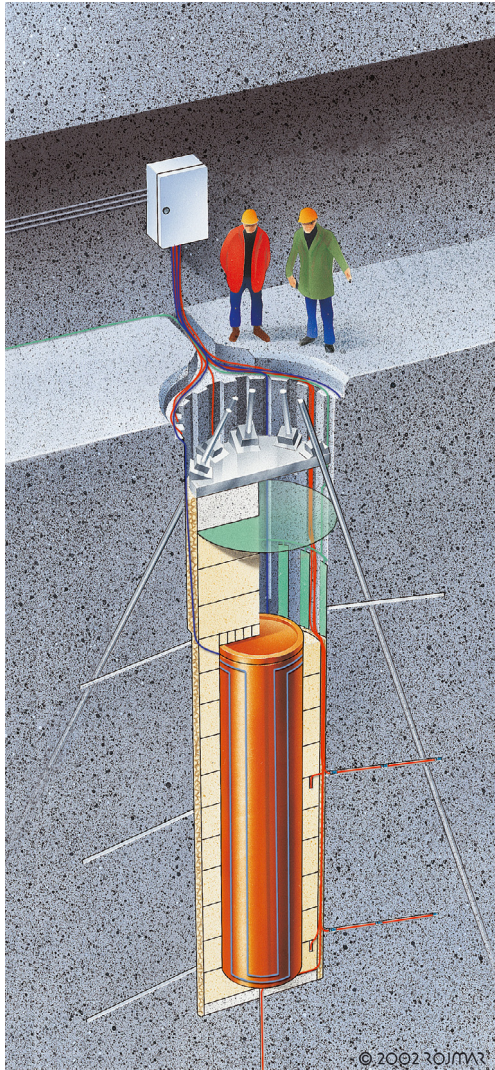

The Canister Retrieval Test is aiming at demonstrating the readiness for recovering of emplaced canisters also after the time when the bentonite is fully saturated.

In the Canister Retrieval Test two full-scale deposition holes have been drilled, at the -420 metre level, for the purpose of testing technology for retrieval of canisters after the buffer has become saturated.

These holes have been used for studies of the drilling process and the rock mechanical consequences of drilling the holes.

Canister and bentonite blocks were emplaced in one of the holes in 2000 and the hole was sealed with a plug, heater turned on and artificial water supply to saturate the buffer started.

The test has been running for more than four years with continuous measurements of the wetting process, temperature, stresses, and strains.

Achievements

A number of heaters failed in the beginning of March and only 4 heaters are still working yielding a power of 1200 W. The water pressure 800 kPa was just after the heater failure reduced to atmospheric pressure in order to try to keep the remaining heaters alive and has since then been kept at atmospheric pressure.

The measurements of a large number of parameters to study the THM-processes and to provide a basis for e.g. modelling purposes have continued. A data report covering the period up to 1st of May 2005 /Goudarzi *et al.*, 2005a/ is available. Modelling of pressure, water content etc. in the buffer during the saturation process is in progress although delayed.

A meeting for discussion when to interrupt the test, excavate the buffer and do the actual retrieval of the canister was held the 25th of April. At the meeting the decision was taken to interrupt the test in late 2005.

2.2 Prototype Repository



The Prototype Repository is located in the TBM-tunnel at the -450 m level and includes six full scale deposition holes. The aims of the Prototype Repository are to demonstrate the integrated function of the repository components and to provide a full-scale reference for comparison with models and assumptions.

The Prototype Repository should, to the extent possible, simulate the real deep repository system regarding geometry, materials, and rock environment.

Instrumentation is used to monitor processes and properties in the canister, buffer material, backfill, and the near-field rock. The evolution will be followed for a long time.

The inner tunnel (Section I) was installed and the plug cast in 2001 and the heaters were turned on one by one. The outer tunnel (Section II) was backfilled in June 2003 and the tunnel plug with two lead-throughs was casted in September the same year.

Achievements

A number of heaters have failed in the canisters, however, only one of the canisters has no heating. The heaters failed in conjunction with the closure of the water drainage of the tunnel. The drainage was opened again when the heaters started to fail and the water pressure was reduced to atmospheric pressure in order to try to keep the remaining heaters alive. A report covering the events at the closing of the drainage of the tunnel will be written.

The data collection system comprises temperature, total pressure, pore water pressure, relative humidity and resistivity measurements in buffer and backfill, as well as temperature and water pressure measurements in boreholes in the rock around the tunnel. The collection of data is continuing and the sensors data report No: 12 covering the period up to 1st of December 2004 is printed. /Goudarzi and Johannesson, 2005/ and the work with data report No: 13 is ongoing. In addition, overhauling of the data acquisition system and rebuilding of the power regulating system for the six canisters are in progress.

The dismantling of one section of the Prototype Repository Project (PRP) has been discussed at different meetings, and the present idea is to await the dismantling of the Canister retrieval test and consequently the dismantling of PRP will be later than 2008.

2.3 Backfill and Plug Test

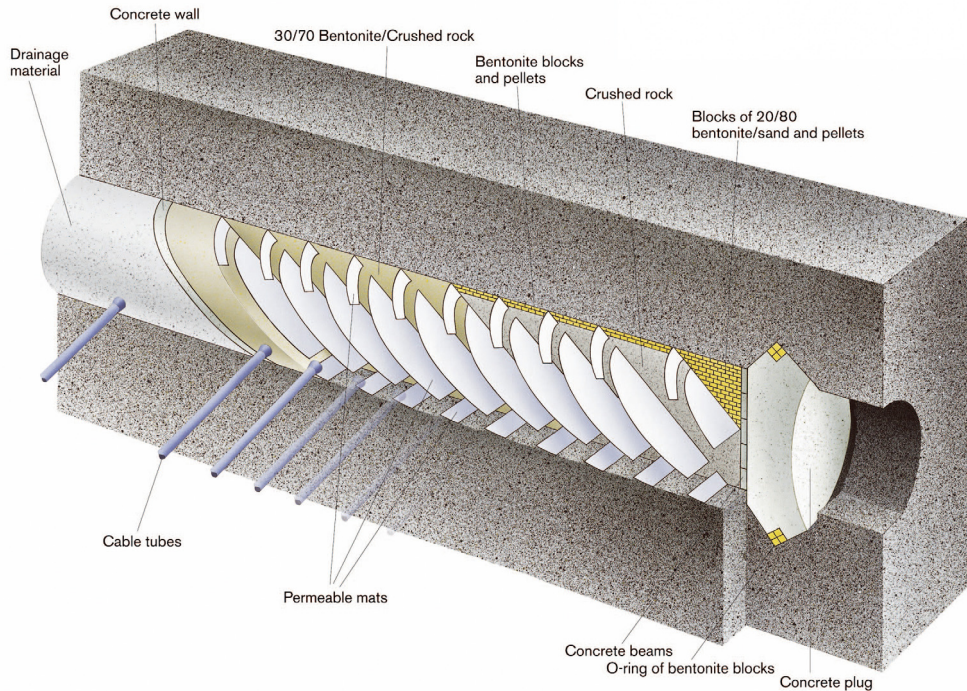

The Backfill and Plug Test includes tests of backfill materials, emplacement methods, and a full-scale plug. The inner part of the tunnel is filled with a mixture of bentonite and crushed rock (30/70) and the outer part is filled with crushed rock and bentonite blocks and pellets at the roof.

The integrated function of the backfill material and the near-field rock in a deposition tunnel excavated by blasting is studied as well as the hydraulic and mechanical functions of the full-scale concrete plug.

The entire test set-up with backfill, instrumentation and casting of the plug was finished in the end of September 1999 and the wetting of the 30/70 mixture through the filter mats started in late 1999.

The backfill was completely water saturated in 2003 and flow testing for measurement of the hydraulic conductivity has been running since late 2003.

Achievements

Water saturation, water pressure and swelling pressure in the backfill and water pressure in the surrounding rock have been continuously measured and registered and the sensors data report No: 10 covering the period up to 1st of January 2005 /Goudarzi *et al.*, 2005b/ is available.

Flow testing of the backfill materials has been finalised in one direction. The strategy for the testing was to successively decrease the water pressure in the mat sections (each section comprises three mats) starting with the mats at the plug. This test series was followed by new flow testing series in the reverse direction. Flow testing of layer A2 (30/70) has been running during May and June. The flow testing was successful in the sections backfilled with a mixture of crushed rock and bentonite (30/70) whereas they did not work in the section with crushed rock. The hydraulic conductivity of the backfill in the measured sections is presently being evaluated.

In addition to the field testing laboratory experiment with the aim to evaluate the hydraulic conductivity of the backfill materials are in progress and modelling work is being done to predict and support the testing.

Layout of the test
 Numbering of backfill sections and permeable mats

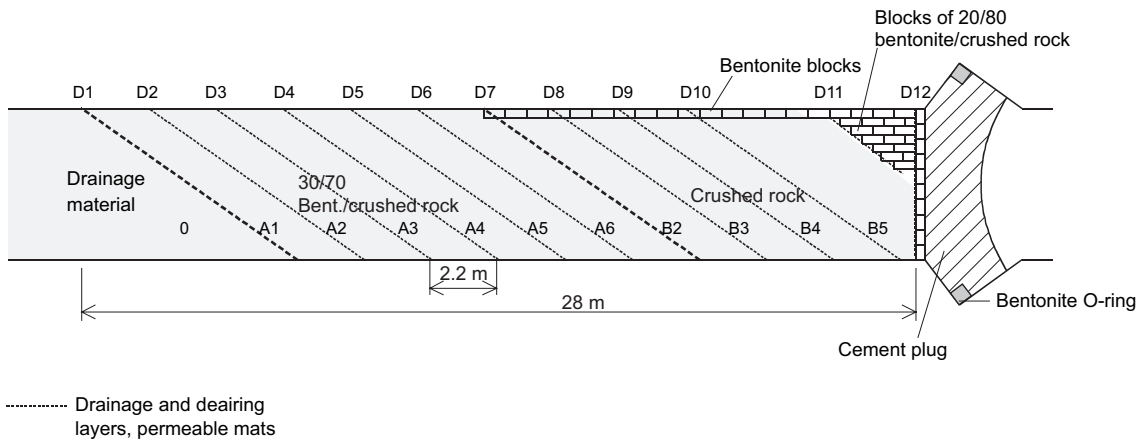

Figure 2-2 Layout of the Backfill and Plug Test showing the numbering of the backfill sections and permeable mats.

2.4 Long Term Test of Buffer Material



The Long Term Test of Buffer Material aims to validate models and hypotheses concerning mineralogy and physical properties in a bentonite buffer.

Test parcels (Figure) containing heater, central tube, clay buffer, instruments, and parameter controlling equipment are placed in boreholes with a diameter of 300 mm and a depth of around 4 m.

Temperature, total pressure, water pressure and water content, are measured during the heating period. At termination of the tests, the parcels are extracted by overlapping core-drilling outside the original borehole. The water distribution in the clay is determined and subsequent well-defined mineralogical analyses and physical testing of the buffer material are made.

The test parcels are also used to study related processes such as bentonite diffusion properties, microbiology, copper corrosion and gas transport in buffer material under conditions similar to those expected in a repository.

Achievements

The pilot tests including the two parcels A1 and S1 (see Table 2-1) are finalised and reported. The A0 parcel has been extracted and has been analysed and a report is in progress. The remaining four long term test parcels have functioned well and temperature, total pressure, water pressure, and water content are continuously measured and registered every hour. The monthly checks of the collected data have been done according to plan.

Discussions with all project members have been held and a decision to finalize the A2 test has been taken. The preparation of the uptake is ongoing and the lift-up is planned to take place in mid January 2006.

Table 2-1 Test series for the Long Term Test of Buffer Material.

Type	No.	max T (°C)	Controlled parameter	Time (years)	Remark
A	1	130	T, [K ⁺], pH, am	1	Reported
A	0	120-150	T, [K ⁺], pH, am	1	Analysed
A	2	120-150	T, [K ⁺], pH, am	5	On-going (uptake in Sep/Oct)
A	3	120-150	T	5	On-going
S	1	90	T	1	Reported
S	2	90	T	5	On-going
S	3	90	T	>>5	On-going

A = adverse conditions

S = standard conditions

T = temperature

[K⁺] = potassium concentration

pH = high pH from cement

am = accessory minerals added

2.5 Cleaning and sealing of investigation boreholes

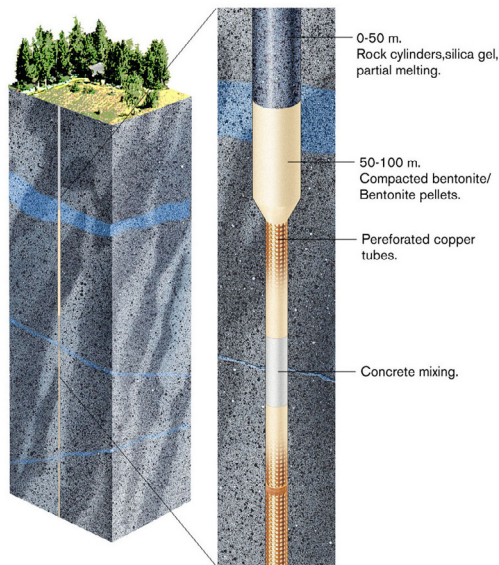

A project, with the aim to identify and demonstrate the best available techniques for cleaning and sealing of investigation boreholes, was initiated in 2002.

The project comprises two phases. Phase 1 was mainly an inventory of available techniques, and Phase 2 aims to develop a complete cleaning and sealing concept and to demonstrate it.

A laboratory test program on candidate sealing materials is part of the project. Short and long boreholes from the surface and from tunnels underground, will be used to demonstrate the plugging concept.

The project is run in co-operation between SKB and Posiva.

Achievements

The first phase of the project is completed and the major conclusion was that smectite clay is recommended as main candidate material for sealing of boreholes in the forthcoming work. The second phase focuses on the development of a complete concept for cleaning and sealing of boreholes. The present design for the borehole seals consists of cylindrical pre-compacted clay blocks contained in perforated copper tubes that are jointed in conjunction with insertion into the boreholes. The final report on the basic concept for borehole plugging is finalised and has been sent to Posiva for review before printing.

Laboratory studies of materials for plugging of boreholes are in progress with the aim to study erosion of material from the plug during installation.

A machine for automatic manufacturing of perforated copper tubes has been constructed. Performed tests show that it works well. The work continues on the design of the copper tube to optimise perforation, hole diameters and joint connections. In parallel, the possibility to install the bentonite without the supporting copper tubes is investigated.

Short boreholes have been drilled underground in Äspö HRL at the -450 metre level, in which the installation of the sealing concept will be tested and the maturation of the bentonite in the borehole seals will be studied. Hydro testing in these short boreholes has started. In addition, the planning of sealing of a vertical borehole in Onkalo in Finland is in progress.

2.6 KBS-3 method with horizontal emplacement

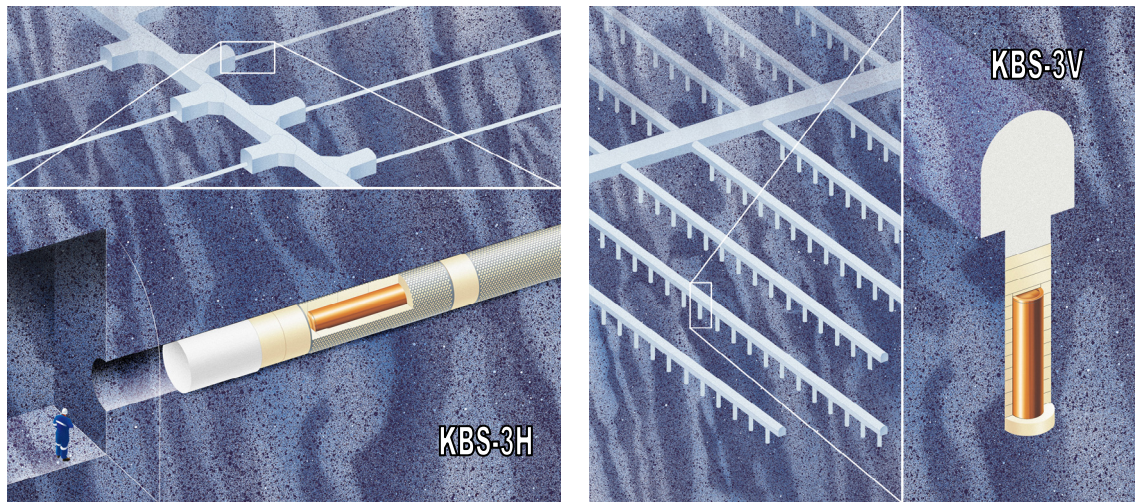

The possibility to modify the reference KBS-3 method and make serial deposition of canisters in long horizontal deposition holes (KBS-3H), instead of deposition of single canisters in vertical deposition holes (KBS-3V), is studied in this project.

One reason for proposing the change is that the deposition tunnels in KBS-3V are not needed if the canisters are disposed in long horizontal deposition holes and the excavated rock volume and the amount of backfill can be considerably reduced. This in turn reduces the environmental impact during the construction of the repository and also the construction costs.

Achievements

The site for the demonstration of the method is located at 220 m depth in Äspö HRL. A niche with a height of about 8 m and a bottom area of 25 x 15 m forms the work area. Two horizontal deposition holes have been excavated, one short with a length of about 15 metres and one long with a length of about 95 metres. The deposition holes were excavated by blind horizontal raise boring. The deposition hole was thereafter cleaned and electric power, light and ventilation installed.

The quality of the drift has been checked by a number of different mapping methods in order to validate the drift quality. The conclusion is that the high quality requirements are almost completely fulfilled. The deposition hole has also been measured with a dummy of the super-container to be used for emplacement. The result of the measuring shows that the free space between the rock face and the container has a mean distance about 38 mm.

During the first quarter 2005 the French company CNIM has completed the basic design of the deposition equipment and started the detailed design and manufacturing. A draft risk assessment report has been delivered to SKB. The manufacturing follows the time schedule and the equipment is planned to be delivered early 2006. The construction of the foundation for the deposition equipment on site began in May.

2.7 Large Scale Gas Injection Test

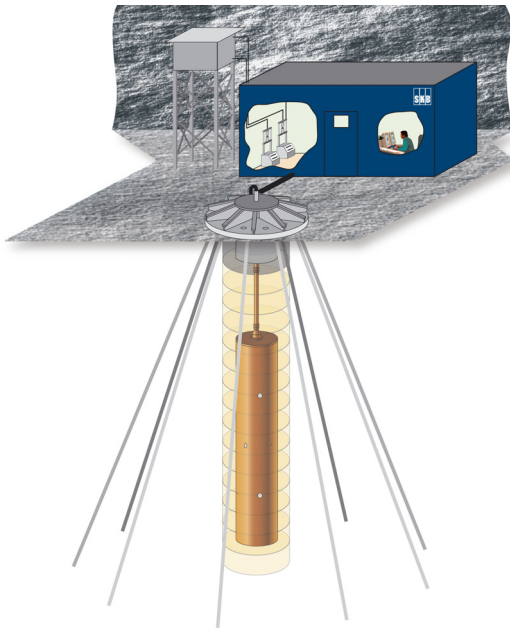

A full-scale canister (without heaters) and a bentonite buffer are installed in an available bored deposition hole in Äspö HRL. Water is, since January 2005, artificially supplied to the buffer at isothermal conditions.

When the buffer is fully saturated gas injection will start, first with small gas volumes and finally with volumes corresponding to gas formation from a defect full-size canister.

SKB has during several years performed a number of experiments with gas injection on MX-80 bentonite. Today, there is a relatively good understanding of the processes determining the gas transport. One remaining question is, however, the importance of the scale. All bentonite experiments so far have been performed in the centimetre scale and the extrapolation of the results from these experiments to repository scale is unclear. Therefore, the Large Scale Gas Injection Test (Lasgit) has been initiated.

The major aims of the project are to:

- Perform and evaluate full-scale gas injection tests based on the KBS-3 concept.
- Answer questions related to up-scaling.
- Get additional information on gas-transport processes.
- Obtain high quality data for testing and validation of models.
- Demonstrate that gas formation in a canister do not have obvious negative consequences for the repository barriers.

Achievements

The test takes place in an earlier drilled deposition hole (DA3147G01) in the TBM tunnel. The information available on the hole was sufficient and no additional characterisation was needed.

The experiment has been installed and the experiment was in operation January 25th, 2005 starting with artificial wetting of the bentonite. The buffer is wetted from the top and through the 12 injection filters in the canister, which at a later stage will be used for injection of gas.

Some problem with piping in the buffer has occurred due to the rapid pressure increase in the deposition hole and the eroded bentonite have been collected and measured. Two pressure relief holes were drilled which solved the problem with piping. The total pressure (swelling pressure) is now increasing in the buffer/rock interface. The gas testing can start when the buffer is water saturated, which is expected some time during 2006.

2.8 Temperature Buffer Test



The French organisation Andra carries out the Temperature Buffer Test (TBT) at Äspö HRL in co-operation with SKB.

The aims of the TBT are to evaluate the benefits of extending the current understanding of the THM behaviour of engineered barriers during the water saturation transient to include high temperatures, above 100°C.

The scientific background to the project relies on results from large-scale field tests on EBS, notably Canister Retrieval Test, Prototype Repository, and Febex (Grimsel Test Site).

The test is located in the same test area as the Canister Retrieval Test, which is in the main test area at the -420 m level.

The TBT experiment includes two heaters in the axis of the deposition hole, one on top of the other, separated by a compacted bentonite block. They are 3 m long and 610 mm in diameter, and are constructed in carbon steel. Each one simulates a different type of confinement system: a bentonite buffer only (bottom section) and a bentonite buffer with inner sand backfill (upper section).

An artificial water pressure is applied in the outer slot between the buffer and rock, which is filled with sand and functions as a filter.

Achievements

The TBT-test is in the operation and data acquisition phase since March 2003. The collection of data is continuing and data report No. 5 covering the period up to 1st of January 2005 has been published /Goudarzi *et al.*, 2005c/. Data acquisition is continuously ongoing and data is reported on a monthly basis. The data link from Äspö to Andra's head office in Paris has been functioning well.

The artificial watering and evaluations are in progress and the bentonite around the upper heater appears to be close to saturation, whereas the innermost parts of the blocks around the lower heater still are unsaturated. The current predictive modelling task is also under evaluation. This concentrates on a mock-up test, conducted by CEA, designed to mimic the conditions at the interior of the buffer around the lower heater. The relative importance of temperature levels and thermal gradients for the thermo-hydraulic evolution around the lower heater are particularly addressed in the mock-up test.

2.9 In situ corrosion testing of miniature canisters

The evolution inside a copper canister with a cast iron insert after failure is of great importance for the release of radionuclides from the canister. After failure of the outer copper shell, the course of the subsequent corrosion in the gap between the copper shell and the cast iron insert will determine the possible scenarios for radionuclide release from the canister. This has been studied experimentally and been modelled. The corrosion will take place under reducing, oxygen free conditions and such conditions are very difficult to create and maintain for longer periods of time in the laboratory. *In situ* experiments at Äspö HRL would be invaluable for understanding the development inside the canister after initial penetration of the outer copper shell.

The objective of the project is to obtain a better understanding of the corrosion processes inside a failed canister. The results of the experiment will be used to support process descriptions and safety analyses.

Miniature copper canisters, with a diameter of 15 cm, will be emplaced in boreholes, with a diameter of 30 cm. The canisters will be exposed to natural reducing groundwater during several years and the experiment will be monitored.

Achievements

The design of the canisters /Smart *et al.*, 2005/ has been finalised and the manufacturing is currently in progress at Serco. The drilling of the pilot 76 mm holes is completed as is the larger diameter holes for the casing in the upper part of the holes. Once the casing has been installed, the final test holes will be drilled. Water flow in each hole will be measured before the drilling of the final five test holes. The installation of the mini-canisters is planned to take place in September – October.

2.10 Rock Shear Experiment

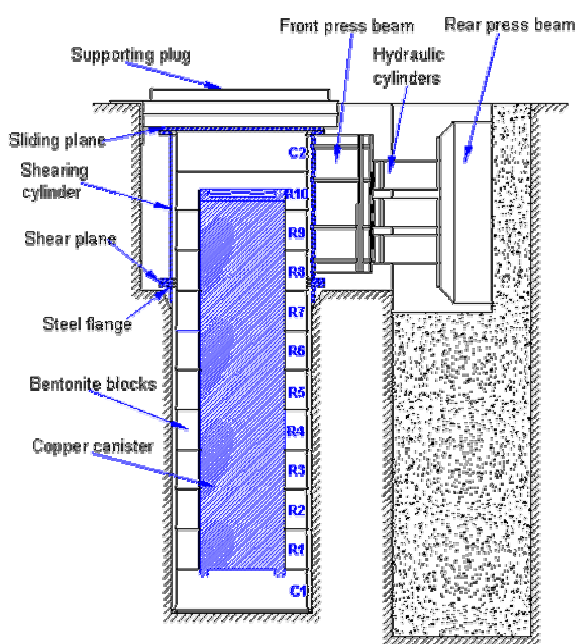

The Rock Shear Experiment (Rose) aims at observing the forces that act on a KBS-3 canister if a displacement of 100 mm would take place in a horizontal fracture that crosses a deposition hole. Such a displacement may be caused by an earthquake, and the test set-up need to provide a shearing motion along the fracture that is equal to the worst expected shearing motion in real life.

The *in situ* test set-up is planned to be installed at the Äspö Pillar Stability site. Two full scale deposition holes already exist with a rock pillar of one metre in between. One deposition hole will be used for the buffer and canister, while the other deposition hole is used for the shearing equipment. So far only a feasibility study has been done and no project decision has yet been taken.

Achievements

The first phase is a pre-study of design and feasibility. The feasibility study is completed and a draft report delivered. Scoping calculations indicating the forces and shearing speed needed have provided the basis for the design of the test set-up. The conclusion from the study is that the test is feasible. A meeting for discussion and decision on how to continue was held 13th of May. At the meeting it was decided to continue with planning and preparations for the test with the aim of performing the actual shear simulation around 2010.

2.11 Learning from experiences

Several large-scale experiments have during the years been installed in Äspö HRL and methods and machines used have provided experiences for refinement and evaluation of limits of the methods applied. Emplacement of buffer and canisters, and backfilling of tunnels have been experienced in Canister Retrieval Test, Prototype Repository and Backfill and Plug Test.

In this project these experiences are documented and analysed with respect to possible improvements as well as acceptable water inflows.

The prime objective is to answer questions and provide information to the work on the SKB's applications for an Encapsulation Plant in 2006 and a Deep Repository in 2008.

The aims are to:

- Compile results from more than ten years of performed engineering experiments in Äspö HRL.
- Compile and evaluate experiences from methods for emplacement of buffer and canisters, backfilling of tunnels, and estimate acceptable water inflows for the applied methods.

Achievements

A draft list of questions to be answered, as a basis for the applications, has been compiled. The first priority issue, the impact of water inflow to tunnels on the backfilling method, material composition and quality of result, has been initiated. Due to priority of available manpower to other SKB projects has the work been on a stand-by mode during the period.

2.12 Task Force on Engineered Barrier Systems

Task Force on Engineered Barrier Systems (EBS) was in 2000 decided to focus on the water saturation process in buffer, backfill and rock. Since the water saturation process also was a part of the modelling work in the Prototype Repository project, the work was transferred to the Prototype Repository project, and the Task Force was put on a stand-by position. As the European Commission funding of the Prototype Repository project ceased in February 2004 it was judged most convenient to activate the Task Force on EBS and continue the modelling work in the Prototype Repository project within this frame, where also modelling work on all other experiments can be conducted.

The Äspö HRL International Joint Committee decided, on May 19th 2004, that in the first phase of this Task Force (period 2004-2008), work should concentrate on:

- THM modelling of processes during water transfer in buffer, backfill and near-field rock (Task 1). Only crystalline rock is considered initially, although other rock types could be incorporated later
- Gas transport in saturated buffer (Task 2).

The objectives of the Tasks are to:

- Verify the capability to model THM and gas migration processes in unsaturated as well as saturated bentonite buffer.
- Refine codes that provide more accurate predictions in relation to the experimental data.
- Develop the codes to 3D standard (long-term objective).

Achievements

Three experiments have been selected for providing data to the modelling teams, one on gas migration and two experiments on THM processes.

The two experiments that have been selected for THM processes are:

- Benchmark 1.1 - THM mock-up experiments on compacted MX-80 bentonite, with two different initial water contents. The experiments have been performed by CEA.
- Benchmark 1.2 - Large-cell experiments are currently being performed by Ciemat in their laboratory in Madrid. One of the tests is kept under isothermal conditions and the other test is performed under a thermal gradient.

The experiment for gas migration has been more complex to compile than assumed and the result could not be reported during the second quarter either.

3 Geo-science

Geo-scientific research is a natural part of the activities at Äspö HRL. Studies are performed in laboratory and field experiments as well as by modelling work. The major aims are to:

- Establish and maintain geo-scientific models of the Äspö HRL rock mass.
- Establish and develop the understanding of the Äspö HRL rock mass properties as well as the knowledge of measurements that can be used in site investigations.
- Determine the rock mechanics characteristics at potential repository depths at candidate sites.
- Develop methods for numerical modelling of stress and strain evolution, and methods for *in situ* stress measurements.

3.1 Geological mapping and modelling

Geological mapping during the present period has been focused on the APSE-project, the KBS-3H project and on drill core loggings connected to various projects (Lasgit, MiniCan and others).

Modelling tasks are performed both in the general geological 3D-model of the Äspö rock volume (the former GeoMod-project) and in more detailed scale in smaller rock volumes.

Besides the regular geological tasks at Äspö HRL, a feasibility study with the acronym RoCS (Rock Characterisation System) is being performed. The purpose of the project is to identify a new method for underground geological mapping to be used in the construction of a future deep repository. The major reasons for initiating the project are aspects on objectivity of the data collected, traceability of the mappings performed, saving of time required for mapping and data treatment and precision in mapping. At the initial feasibility study-stage, the major objective is to establish a knowledge base concerning existing and possible future methods and techniques to be used for a mapping system suitable for SKB-Posiva requirements. Also, there is an aim to investigate external and internal requirements on a new rock characterisation system. The project is performed in cooperation with Posiva.

Achievements

The mapping of the pillar walls at the Äspö Pillar Stability site was finished already during the first quarter. The mapping of the upper surfaces of the cut out pillar blocks started during the first quarter and is now finalised and the TMS-digitizing, data feeding and reporting is in progress, see Section 3.6.

One project of detailed modelling has been completed during the present period, a 3D-model of the KBS-3H rock volume at 220 m level, based on the core loggings preceding the regular mappings of the deposition holes. Also, a geological-hydrological model of the 450 m-level has been planned during the period.

Undertaken activities in the RoCS feasibility study are in accordance with the project time plan and the consultants to participate in the scientific committee have been contracted. In the feasibility study different mapping techniques has been tested, e.g. digital colour photogrammetry and laser scanning techniques. Also, a larger project meeting has been held at Äspö.

3.2 Heat transport

The aim of the heat transport project is to develop a strategy for site descriptive thermal modelling to decrease the uncertainties in the estimates of the temperature field in a repository. Less uncertain estimates of the temperature field make it possible to optimise the distance between canisters in the repository layout. The work includes measurements of thermal properties of the rock, examinations of the thermal conductivity distributions, analyses of thermal properties at different scales, and inverse modelling of thermal properties from the measured temperature changes in the rock mass at the prototype repository. In order to determine the significant scale for the variation of thermal properties in a repository, a large number of numerical simulations are included in the work.

Achievements

Three reports dealing with heat transport were completed during 2002 and 2003 and a strategy for the thermal model development during site investigations has been presented /Sundberg, 2003/.

Measurements in laboratory of thermal conductivity and thermal diffusivity have been conducted. The purpose of the measurements was to study scale effects of the thermal properties. The uncertainties and scale dependencies in data are now being evaluated and will be reported during the summer of 2005.

3.3 Inflow predictions

SKB has conducted a number of large field tests where predictions of inflow into tunnels or depositions holes have been a component: Site characterisation and validation tests in Stripa, Prototype Repository, and Groundwater degassing and two-phase flow experiments in Äspö HRL. The results from these tests show that when going from a borehole to a larger diameter hole, the inflow into the larger hole is often less than predicted, and the explanation for this is not yet well understood.

The ability to predict inflow is of importance from several aspects:

- Evaluation of experimental results from Äspö HRL. A good understanding of the mechanisms controlling inflow would improve the possibilities for good experimental set-ups and accurate result interpretation.
- Evaluation and comparisons between potential repository sites. It is desirable to be able to predict the inflow conditions into the excavations, already before the construction work starts, based on hydraulic measurements made in small diameter boreholes.

- Evaluation of the expected bentonite buffer behaviour. The amount of inflow into deposition holes will influence the time needed for saturation and also the expected performance of the buffer.
- Design and optimisation of the repository layout. Poor prediction of inflow could lead to less optimal design alternatives.

Achievements

So far, extensive numerical analyses using the three-dimensional distinct element code 3DEC /Itasca, 2003/ have been conducted. The aim has been to improve the knowledge about the effect of the effective stress redistribution, caused by excavation, on the fracture inflow into deposition holes considering single-phase flow /Mas Ivars, 2004/.

A report has been written about the HM (hydro-mechanical) data acquisition project at the APSE site /Mas Ivars, 2005/. In this project a large field experiment was conducted with the aim of acquiring hydro-mechanical data during the drilling of the de-stressing slot at the APSE site (see section 3.6). The de-stressing of the pillar was expected to cause a number of coupled hydro-mechanical effects in two NW-SE striking sub-vertical conductive fractures intersecting the deposition hole size borehole DQ0066G01. The effective normal stress acting on the conductive fractures was expected to change with the consequent influence in inflow. Besides, the change in normal stress would affect the fracture shear strength, which, combined with the change in shear stress along the fracture, could lead to slip and dilation of the fracture. Therefore, fracture displacements, fracture inflow and total inflow into the deposition hole size borehole (DQ0066G01) were monitored during the drilling of the de-stressing slot.

To better understand the data acquired in the HM data acquisition project, a three dimensional mechanical modelling study of the de-stressing of the APSE pillar has been carried out using 3DEC. After the pillar was removed, fracture mapping of the pillar walls was performed and the main fractures in the study volume were included in the three dimensional model. The results from this modelling exercise show the stress redistribution in the APSE tunnel during the drilling of the de-stressing slot.

Fracture samples from three boreholes in the APSE volume were selected and mechanically tested for normal and shear behaviour at SP laboratory. The results will be used to improve the input data for the next modelling phase.

Shear flow tests will be conducted on large samples taken from one of the sub-vertical conductive fractures monitored during the drilling of the de-stressing slot at the APSE site. Theoretical and numerical analysis will be conducted with the results obtained. The objective is to improve already existing coupled hydro-mechanical fracture constitutive models so they can better represent the type of conductive fractures present at Äspö HRL.

3.4 Seismic influence on the groundwater system

The Hydro Monitoring System (HMS) registers at the moment the piezometric head in 409 positions underground in the Äspö HRL. An induced change of the head with more than 2 kPa triggers an intensive sampling. All measured data are stored in a database.

The data in the database are assumed to bear witness of different seismic activities in Sweden but also abroad, dependent on the magnitude of the event, as well as the position of the epicentre. By analysing the data on changes in the piezometric head at Äspö connections to specific seismic events are expected to be established.

Achievements

Data measured during the second quarter are in the same way as earlier stored in SKB's site characterisation database, Sicada, waiting for future analysis.

3.5 Rock mechanics

Rock Mechanics studies are performed with the aims to increase the understanding of the mechanical properties of the rock but also to recommend methods for measurements and analyses. This is done by laboratory experiments and modelling at different scales and comprises:

- Natural conditions and dynamic processes in natural rock.
- Influences of mechanical, thermal, and hydraulic processes in the near-field rock including effects of the backfill.

During 2005 work will be performed within the following projects:

- Coupled processes in rock including dynamic processes at natural conditions.
- Stress measurements and stress interpretation methods
- Understanding of variability of rock under different load conditions Methods to calculate stability of underground openings and large scale failures (dynamic effects of earth quakes).
- Mechanical processes in the interface between rock and backfill.
- Äspö Pillar Stability Experiment.
- Rock Shear Experiment

Achievements

During this quarter the main activities have been within the Äspö Pillar stability experiment and the Rock Shear Experiment, see Sections 3.6 and 3.7.

3.6 Äspö Pillar Stability Experiment

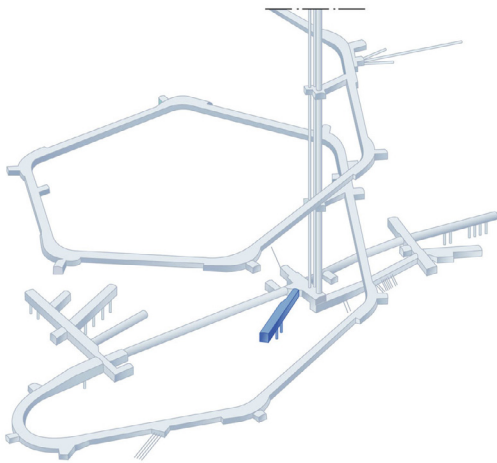

The major aims with the Pillar Stability Experiment are to demonstrate the capability to predict spalling in fractured rock mass and the effect of backfill on the propagation of micro cracks. The experiment is a complement to an earlier study performed at URL in Canada.

A new tunnel was excavated at Äspö HRL to ensure that the experiment was carried out in a rock mass with a virgin stress field. The site is located at the -450 m level. The pillar was created between two vertical deposition holes drilled in the floor of the tunnel

The stress in the pillar was further increased by a thermal load to reach a stress state that induced brittle failure/spalling. One of the boreholes was subjected to an internal water pressure via a rubber bladder giving a confining pressure of (0.7 MPa).

The heating phase of the experiment was finished in mid July 2004. Spalling occurred to almost five metres depth in the open borehole and good measuring series were achieved with all the instruments used.

Achievements

The pillar has been removed in large blocks, see the figure above. The pillar had to be de-stressed before the blocks could be cut out. The de-stressing induced some unfortunate damage to the pillar. Totally, five pillar blocks have been sawn and lifted out. The mapping of the pillar walls and the blocks is finished, see Section 3.1. The reporting of the mapping is in progress and the information from the mapping will be digitised and stored in the Tunnel Mapping System (TMS).

The activities at the experimental site have been finished and the reporting of the field experiments is in progress. The reports will contain (a) the acoustic emission results, (b) general observations with temperature and displacement monitoring, and (c) a detailed description of the instrument set up and the instruments themselves. The three reports have been delayed but are available in draft form.

4 Natural barriers

At the Äspö HRL experiments are performed at conditions that are expected to prevail at repository depth. The experiments are related to the rock, its properties, and *in situ* environmental conditions. The goals are to increase the scientific knowledge of the safety margins of the deep repository and to provide data for performance and safety assessment and thereby clearly present the role of the geosphere for the barrier functions: isolation, retardation and dilution. Processes that influence migration of species along a natural rock fracture are shown Figure 4-1.

Tests of models for groundwater flow, radionuclide migration and chemical/biological processes are one of the main purposes of the Äspö HRL. The programme includes projects with the aim to evaluate the usefulness and reliability of different models and to develop and test methods for determination of parameters required as input to the models.

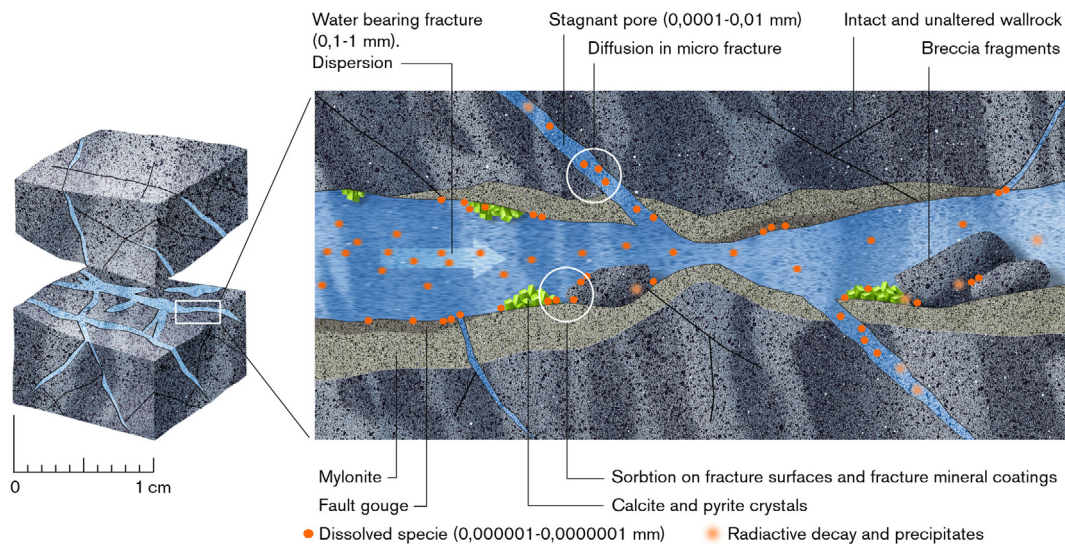
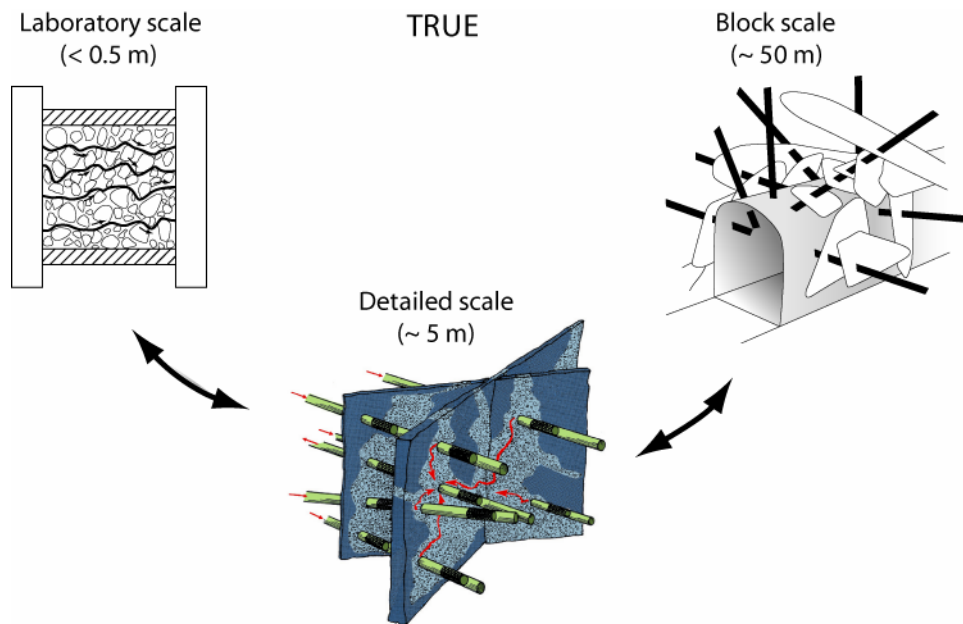

Figure 4-1 Processes that influence migration of species along a natural rock fracture.

4.1 Tracer Retention Understanding Experiments



Tracer tests with non-sorbing and sorbing tracers are carried out in the True family of projects. These are conducted at different scales; laboratory scale (< 0.5 m), detailed scale (<10 m) and block scale (up to 100 m) with the aim to improve understanding of transport and retention in fractured rock. The work includes building of hydrostructural models and conceptual microstructure models. Numerical models are used to assess the relative contribution of flow-field related effects and acting processes (diffusion and sorption) on *in situ* retention.

The first *in situ* experiment (True-1) performed in the detailed scale and the True Block Scale series of experiments have come to their respective conclusion and the evaluation and final reporting are completed. Complementary field work and modelling are currently performed as part of two separate but closely coordinated continuation projects.

The True Block Scale Continuation project aims at obtaining additional understanding of the True Block Scale site.

The True-1 Continuation project is a continuation of the True-1 experiment. According to present plans the True-1 site will be injected with resin and excavated and analysed. The objectives are to obtain insight in the internal structure of the investigated feature and to study fixation of sorbing radioactive tracers. Prior to the resin injection in Feature A complementary hydraulic and tracer tests are performed to better understand Feature A and its relation to the surrounding fracture network. In addition, a dress rehearsal of *in situ* resin injection is realised through a characterisation project focused on fault rock zones. Furthermore, attempts are made to assess fracture apertures using radon concentrations in groundwater.

4.1.1 True Block Scale Continuation

The True Block Scale Continuation (BS2) project has its main focus on the existing True Block Scale site. The True Block Scale Continuation is divided into two separate phases:

- BS2a Complementary modelling work in support of BS2 *in situ* tests. Continuation of the True Block Scale (phase C) pumping and sampling including employment of developed enrichment techniques to lower detection limits.
- BS2b Additional *in situ* tracer tests based on the outcome of the BS2a analysis. *In situ* tests are preceded by reassessment of the need to optimise/remediate the piezometer array.

Achievements

The official part of BS2b sorbing experiments was terminated as planned in mid September 2004 but sampling on a low level of ambition was continued until the end of the year.

Model predictions were conducted by four modelling teams, using different modelling methodologies and model codes. The modelling teams included Posiva VTT, JNC-Golder, Andra-Itasca and SKB-KTH/WRE. The individual modelling evaluations are underway. Draft evaluation reports were produced by three of the modelling teams by the end of June. The obtained results provide a preliminary assessment of background fracture retention properties (diffusivity/porosity/sorption) in the investigated background fracture flow paths. The results indicated reduced retention properties relative to the fault type flow path in Structure #19.

A technical committee meeting (TC#7) was held on May 19-20, which focused on individual evaluations, joint reporting and planning for a review seminar in mid september.

4.1.2 True-1 Continuation

The True-1 Continuation project is a continuation of the True-1 experiments, and the experimental focus is on the True-1 site. The continuation aims at conducting the planned injection of epoxy resin resin I Feature A at the True-1 site and subsequent overcoring an analysis (TRUE-1 Completion, see below). at the True-1 site.

In preparation for the above activity (a) complementary tests have been conducted at the site to improve the understanding of the three-dimensional nature of flow and transport in the vicinity of Feature. These tests have demonstrated the relative isolation of Feature A in relation to its closest environment. Furthermore, application tests (b) of the developed epoxy resin technology to fault rock zones have been conducted on fault zones of variable character distributed along the Äspö HRL access tunnel.

Laboratory sorption experiments have also been conducted with the purpose of verifying K_d -values calculated for altered wall rock and fault gouge based on CEC, mineralogy, selectivity coefficients and water chemistry. Finally, a series of scientific papers relating to the original True-1 Project focussed on Feature A are underway. A previously included component with the purpose of assessing fracture aperture from radon data has been omitted due to resources prioritisation..

Achievements

Fault Rock Zones Characterisation

Ongoing activities include work in three areas: (a) image processing with the aim to get images with desired colour and contrast of the slices, (b) image analysis to find the desired parameters, and (c) various types of visualisations to get the overall variability within and between rock slices.

TRUE-1 papers

Three scientific papers on the True team analysis of the True-1 experiments are being written. The papers tentatively cover the following topics:

- Test results, modelling and effective parameter estimation

- Characterisation of *in situ* retention parameters
- Interpretation of tracer test results using prior information of retention properties.

TRUE-1 Completion

The True-1 Completion project with epoxy injection of Feature A at the True-1 site has been initiated. The completion project will comprise, complementary tracer tests (e.g. SWIW-tests and in situ cation exchange tests preceding the impregnation, characterisation of parts of the flowing paths/-, sorption sites, update of microstructure model. Prior to the in situ testing a re-instrumentation and establishment of infrastructure at the site is a necessary prerequisite. A complication for the scheduling of future work at the True-1 site lies in the fact that the True 1 and LTDE sites are hydraulically connected, hence the reinstrumentation to avoid such short-circuiting. A priority for advancing LTDE has been set by SKB and consequently all activities at the True-1 site will be postponed until the LTDE functionality tests have been accomplished.

4.2 Long Term Diffusion Experiment

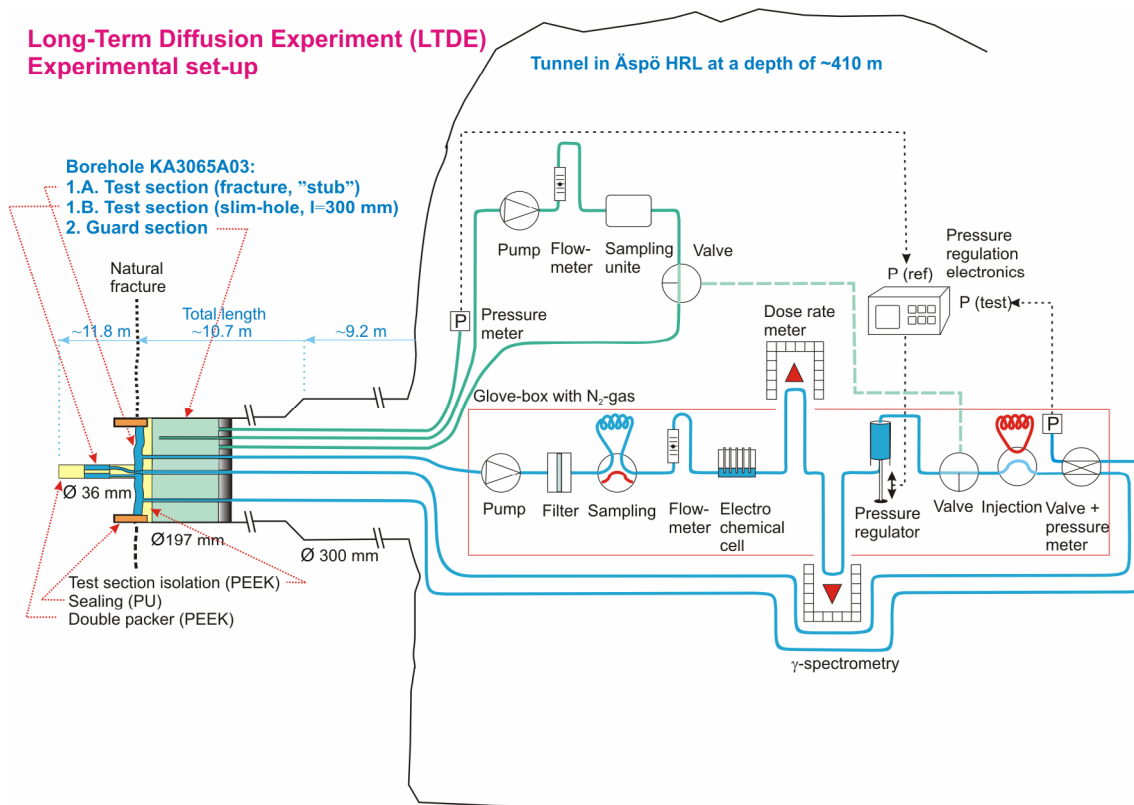

This experiment is performed to investigate diffusion and sorption of solutes in the vicinity of a natural fracture into the matrix rock and directly from a borehole into the matrix rock.

The aims are to improve the understanding of diffusion and sorption processes and to obtain diffusion and sorption data at *in situ* conditions.

A core stub with a natural fracture surface is isolated in the bottom of a large diameter telescoped borehole and a small-diameter borehole is drilled through the core stub and beyond into the intact unaltered bedrock. Tracers will be circulated over a period of two to four years after which the borehole is over-cored and analysed for tracer content.

Achievements

The pre-test programme for evaluation of the hydrological conditions in the vicinity of the experimental borehole, KA3065A03, and possible hydrological interferences from other activities in Äspö HRL are completed. The evaluation and documentation are in progress.

The experimental set-up in the LTDE-borehole KA3065A03 is now running. The circulation flow rate in the test loop is about 20 mL/min. The installation during the first quarter of a new electronic unit, together with a new reference electrode in the electrochemical flow cell (pH and redox measurements) seems promising, giving stable output signals. The LTDE alarm system connection to Äspö HRL Alpha system is completed. The preparations for the first part of the *in situ* experiments are in progress. However, the time schedule for the functionality test with shortlived radionuclides and also for the forthcoming part of the LTDE experiments has been adjusted and is now planned during the period August-November.

Within the framework of collaboration between SKB and OPG's Nuclear Waste Management Division laboratory experiments on core samples from the LTDE borehole KA3065A03 are in progress at AECL in Canada. Experimental programme consists of porosity measurements, diffusion cell experiments, radial diffusion experiments, and permeability measurements. So far the porosity measurements have been accomplished, the diffusion cell experiments and the radial diffusion experiment are in progress.

4.3 Radionuclide Retention Experiments

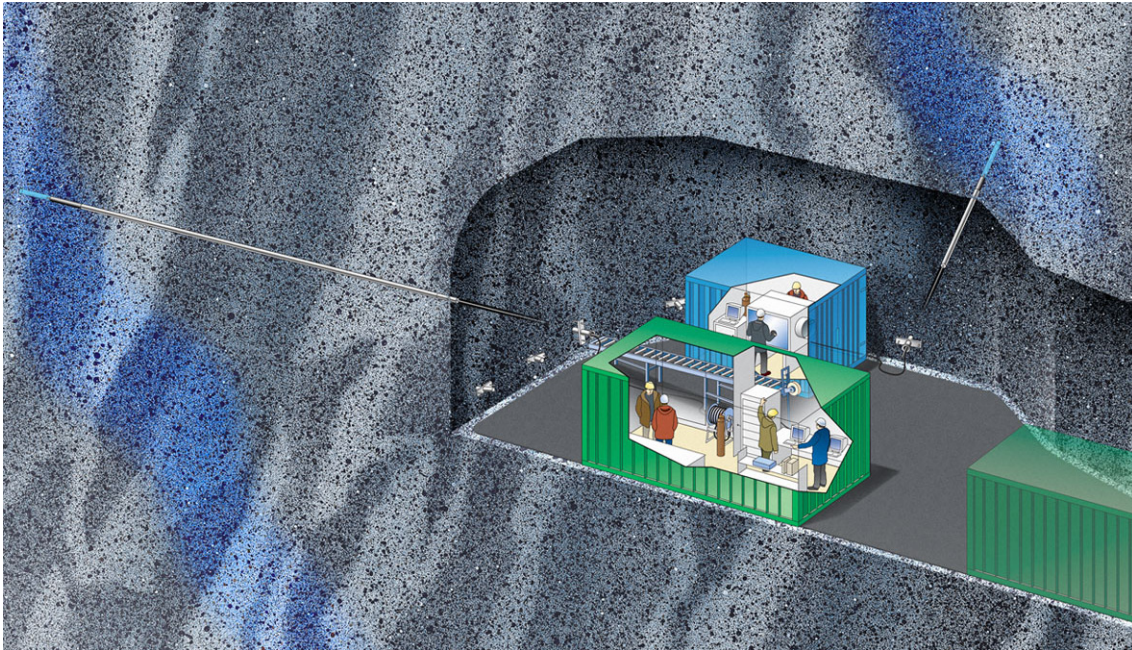

Radionuclide Retention Experiments are carried out with the aim to confirm results of laboratory studies *in situ*, where natural conditions prevail concerning e.g. redox conditions, contents of colloids, organic matter, and bacteria in the groundwater.

The experiments are carried out in special borehole laboratories, Chemlab 1 and Chemlab 2, designed for different kinds of *in situ* experiments. The laboratories are installed in boreholes and experiments can be carried out on bentonite samples and on tiny rock fractures in drill cores.

Chemlab 1:

- Investigations of the influence of radiolysis products on the migration of the redox-sensitive element technetium in bentonite (finalised)
- Investigations of the transport resistance at the buffer/rock interface (planned)

Chemlab 2:

- Migration experiments with actinides in a rock fracture (on-going)
- Study leaching of spent fuel at repository conditions (planned)

Achievements

The *Radiolysis experiments*, in Chemlab 1, have been finalised and the major conclusions are that technetium was to some extent oxidised in the direct radiolysis experiment and had started to diffuse whereas in the indirect radiolysis experiment technetium was only found at its original position and had probably not been oxidised. The evaluation of data is finished and reported /Jansson and Eriksen, 2005/. No additional radiolysis experiments are planned.

In the *Actinide migration* experiments, performed in Chemlab 2, the retention of redox sensitive radionuclides in a rock core with a longitudinal natural fracture is investigated. After saturation with groundwater, radionuclides are injected into the fracture. Groundwater is then pumped through the fracture for a long period of time. The water exiting the core is collected in fractions in a glove box placed in the gallery. In the first two field experiments the retention of the actinides Pu, Am and Np have been investigated. The last field experiment with U and Tc is now terminated.

The core from the experiment, the reservoir containing the remaining radionuclide solution as well as the last 15 samples taken in the glove box have been sent to Karlsruhe for analysis. It has been decided that the final report on the Actinide experiments will consist of the five internal FZK/INE reports that have been published

so far as well as a yet unpublished sixth report (with the results from the on-going experiment) and a foreword/summary for the six reports.

Chemlab 1 will according to the present plan be used for experiments on *Transport resistance at the buffer/rock interface*. The project aims at examining whether there is a transport resistance when radionuclides change media from diffusing in bentonite clay to transport with groundwater in a fracture and if so, the magnitude of the resistance shall be determined.

In Chemlab 2 it is planned to perform *Spent fuel leaching experiments*. The aims are to examine which radionuclides are released and to what extent when spent nuclear fuel is leached with groundwater under repository conditions.

4.4 Colloid Project

Borehole specific measurements

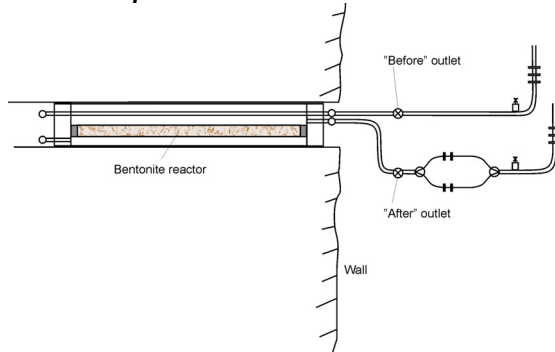

Colloid dipole experiment

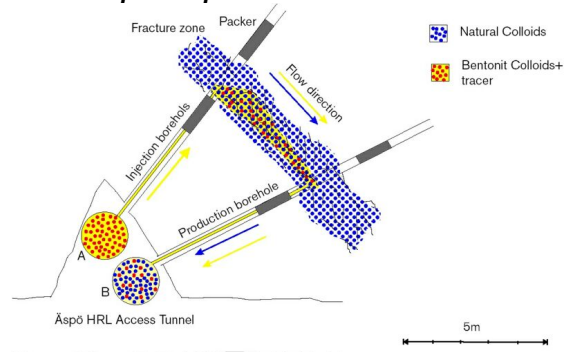

In the Colloid Project the concentration, stability, and mobility of colloids in the Äspö environment are studied. The project comprises studies of the potential of colloids to enhance solute transport and the potential of bentonite clay as a source for colloid generation. The Colloid Project includes laboratory experiments, background measurements, borehole specific measurements, and colloid dipole experiments.

Achievements

The *Borehole specific measurements* that were initiated in January 2003, when six "colloid reactors" were installed in four boreholes in Äspö HRL and in two boreholes at Olkiluoto, have all been finalised. The results show no leaching out of bentonite colloids neither in Äspö nor in Olkiluoto, which is in accordance with theory. A draft version of the final report, including laboratory experiments, background measurements and borehole specific measurements, has been compiled and is now being reviewed.

The preparations for the *Colloid dipole experiment* that will be carried out in co-operation between SKB, INE, AECL and Posiva are in progress. Stability experiments on bentonite colloids are performed in the laboratory where Ca, Na and DOC contents in the water are varied. The experiments will continue with stability experiments on latex-colloids in a cocktail with uranine and bentonite colloids.

The field experiments will be coordinated with the True Continuation experiment and Feature A at the True-1 site is chosen as experimental site. Predictive modelling to define initial conditions for the *in situ* experiments is in progress. In addition, laboratory experiments on a granite block will be performed by AECL, Pinawa.

4.5 Microbe Project



The Microbe Project has been initiated in the Äspö HRL for studies of the microbial activity in groundwater at *in situ* conditions. The major objectives are to:

- Offer proper circumstances for research on the effect of microbial activity on the long- term chemical stability of the repository environment.
- Provide *in situ* conditions for the study of bio-mobilisation of radionuclides.
- Present a range of conditions relevant for the study of bio-immobilisation of radionuclides.
- Enable investigations of bio-corrosion of copper under conditions relevant for a high level radioactive waste repository.
- Constitute a reference site for testing and development of methods used in the site investigations.

The main Microbe site is on the -450 m level where a laboratory container with benches, an anaerobic gas box and an advanced climate control system is located. Three core drilled holes, KJ0050F01, KJ0052F01 and KJ0052F03, inter-secting water conducting fractures are connected to the Microbe laboratory via tubings. Each borehole has been equipped with a circulation system offering 2000 cm² of test surface.

Retention of naturally occurring trace elements in the groundwater by Biological Iron Oxides is investigated at a site at tunnel length 2200A metre. There is a vault with a borehole that delivers groundwater rich in ferrous iron and iron oxidising bacteria. The borehole is connected to two 200 x 30 x 20 cm artificial channels that mimic ditches in the tunnel. The channels have rock and artificial plastic support that stimulate Biological Iron Oxide formation.

Achievements

During the field work activity in March it was revealed that drilling for the copper canister corrosion experiments had lowered the pressure at the Microbe site with more than three bars. Upconing was already established at the site, and the intensive flowing may have accelerated this process significantly for the Microbe site. The canister corrosion boreholes were plugged mid May. However, they continued to leak and the area must be injected. This is planned to be done during late fall 2005. The Microbe site has been sampled to evaluate the number of microbes in the groundwater and to analyse

gases. Samples were taken as planned May 12th and June 9th, and evaluation and reporting is in progress. Weekly class 2 chemistry samples and sulphide are being taken weekly at all three Microbe boreholes to monitor the disturbance from the copper corrosion experiment.

Sampling for the iron oxide project, see Section 4.9, was performed, at the Microbe site on the –450 m level and the BIOS site at tunnel length 2200 m, in the beginning of June.

In addition, the Microbe site was lectured and demonstrated for students from Oskarshamn and German scientists from University of Göttingen in May. The group of scientists has substantial funding from the German research council to perform deep biosphere research and it has been agreed that they can use Äspö HRL as one of their windows to the deep biosphere.

4.6 Matrix Fluid Chemistry

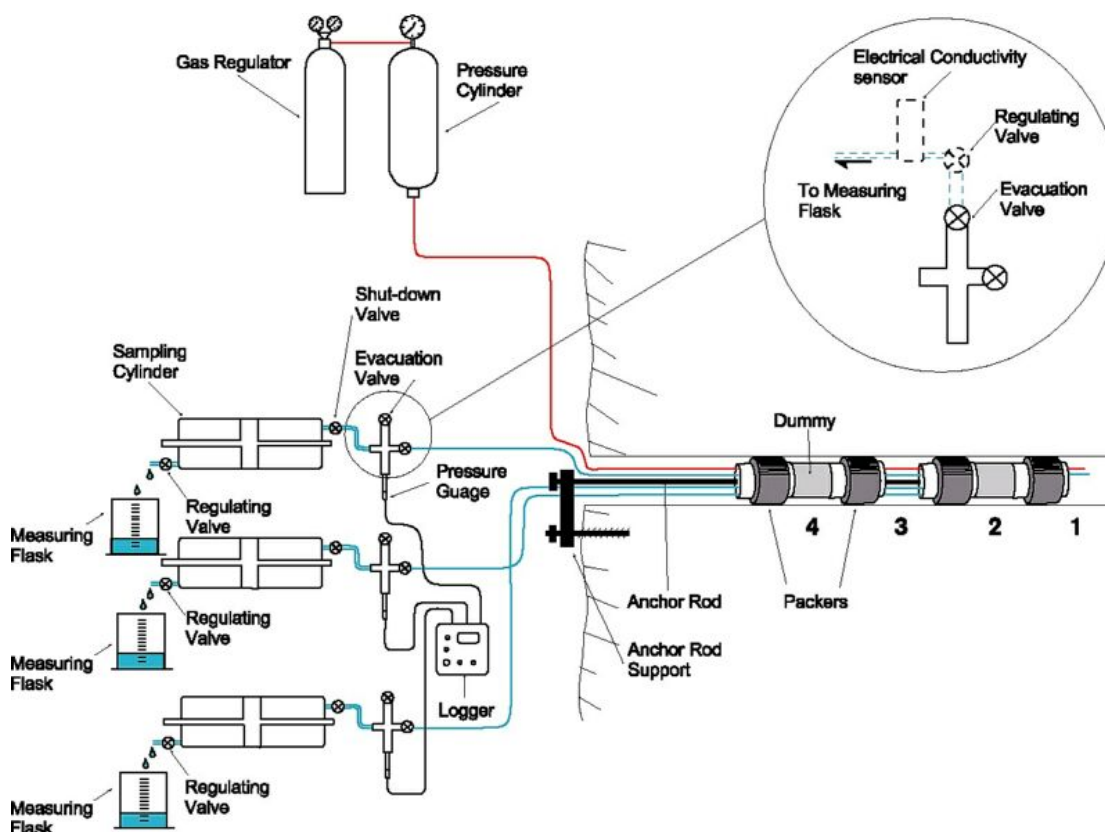

The main objectives of the Matrix Fluid Chemistry experiment are to understand the origin and age of fluids/groundwaters in the rock matrix pore space and in micro-fractures, and their possible influence on the chemistry of the groundwaters from the more highly permeable bedrock.

Matrix fluids are sampled from a borehole drilled into the rock matrix. Fluid inclusions in core samples have also been studied to determine their contribution, if any, to the composition of the matrix fluids/groundwaters.

A first phase of the project is finalised and reported /Smellie *et al.*, 2003/. The major conclusion is that pore water can successfully be sampled from the rock matrix and there is no major difference in chemistry compared to groundwaters from more highly conductive fracture zones in the near-vicinity.

A continuation phase will focus on areas of uncertainty which remain to be addressed.

Achievements

The next stage of the Matrix Continuation Project will consist of: (a) sampling of the accumulated matrix water from the isolated packed-off borehole sections, and (b) removal and modification of the packer equipment in order to conduct the hydraulic testing programme.

The sampling of the matrix water which has accumulated during the last two years from the isolated packed-off borehole sections was carried out successfully on April 22nd. The samples will be analysed at the Äspö Laboratory (alkalinity), the University of Bern (major and trace ions and isotopes) and the University of Göteborg (dissolved gases).

Porosity measurements on drillcore material performed in the laboratory to supplement data from the Matrix Fluid Chemistry Experiment have been carried out successfully. The results from the measurements are reported in an internal technical document.

4.7 Task Force on Modelling of Groundwater Flow and Transport of Solutes

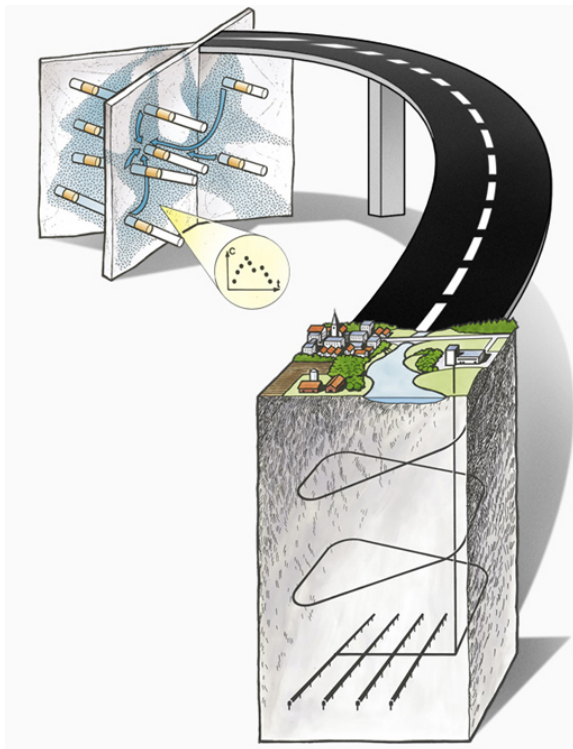

The Äspö Task Force on Modelling of Groundwater Flow and Transport of Solutes is a forum for the organisations supporting the Äspö HRL to interact in the area of conceptual and numerical modelling of groundwater flow and transport of solutes in fractured rock.

The Task Force shall propose, review, evaluate and contribute to the modelling work in the project. In addition, the Task Force shall interact with the principal investigators responsible for carrying out experimental and modelling works for Äspö HRL.

The work within the Äspö Task Force constitutes an important part of the international co-operation within the Äspö Hard Rock Laboratory.

Achievements

In the Task Force, work has been in progress in Task 6 – Performance Assessment Modelling Using Site Characterisation Data. Task 6 tries to bridge the gap between Performance Assessment (PA) and Site Characterisation (SC) models by applying both approaches for the same tracer experiment. It is hoped that this will help to identify the relevant conceptualisations (in processes/structures) for long term PA predictions and identify site characterisation data requirements to support PA calculations.

The 20th Task Force meeting was held the 17th to 19th of May at Äspö HRL. At this meeting e.g. the final modelling results for Task 6F were presented and discussed. It was also decided to present a summary of the outcome of Task 6 in a scientific paper.

The status of the specific modelling tasks is given in brackets in Table 4-1.

Table 4-1 Task 6 - description and status of the specific modelling sub-tasks.

6A	Model and reproduce selected True-1 tests with a PA model and/or a SC model to provide a common reference. (Finalised, modelling reports printed and external review in progress).
6B	Model selected PA cases at the True-1 site with new PA relevant (long term/base case) boundary conditions and temporal scales. This task serves as means to understand the differences between the use of SC-type and PA-type models, and the influence of various assumptions made for PA calculations for extrapolation in time. (Finalised, modelling reports printed and external review in progress).
6C	Develop semi-synthetic, fractured granite hydrostructural models. Two scales are supported (200 m block scale and 2000 m site-scale). The models are developed based on data from the Prototype Repository, True Block Scale, True-1, and Fracture Characterisation and Classification project (FCC). (Finalised, printed as /Dershowitz <i>et al.</i> , 2003/ and external review in progress).
6D	This sub-task is similar to sub-task 6A, and is using the synthetic structural model in addition to a 50 to 100 m scale True-Block Scale tracer experiment. (In progress, draft reports available and review in progress).
6E	This sub-task extends the sub-task 6D transport calculations to a reference set of PA time scales and boundary conditions. (In progress, draft reports available and review in progress).
6F	Task 6F is a sensitivity study, which is proposed to address simple test cases, individual tasks to explore processes, and to test model functionality. (In progress).
7	Long-term pumping experiment. (Initiated).

4.8 Padamot

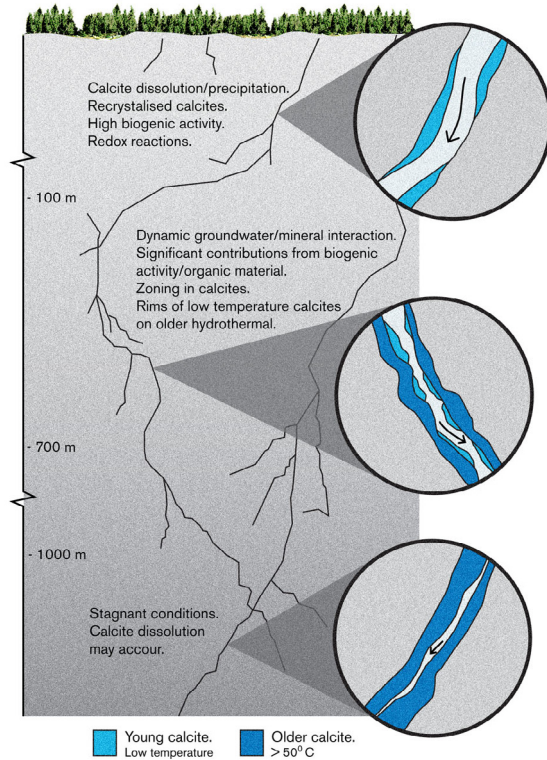

Potential calcite-groundwater interaction at various depths at Äspö.

Padamot (Palaeohydrogeological Data Analysis and Model Testing) is a EC-project and will investigate changes in groundwater conditions as a result of changing climate. Because the long term safety of an underground repository depends on the stability of the repository environment, demonstration that climatic impacts attenuate with depth is important. Currently, scenarios for groundwater evolution relating to climate changes are poorly constrained by data and process understanding.

The objectives of Padamot are to:

- Improve understanding and prioritise palaeohydrogeological information for use in safety assessments.
- Collect chemical/isotopic data using advanced analytical methods.
- Construct a database of relevant information and develop numerical models to test hypotheses.
- Integrate and synthesise results to constrain scenarios used in performance assessments.
- Disseminate the results to the scientific community.

The project comprises analytical and modelling tasks. Deep borehole cores from rocks at the

Äspö Underground Laboratory and Laxemar (KXL01) are used in the analytical study.

Achievements

The Swedish part of Work Package 2, Palaeohydrogeological Characterisation of Sites, is finalised. However, BGS are still in the phase of finalising the reporting of the entire work package (including the submissions from the other participating countries).

The Padamot EC-project are being finalised but the Swedish part of the project will be extended. The planning of the continuation phase is in progress, including uranium series analyses (USD) and additional sampling for biomarker analyses. Contacts have been taken with Gus MacKenzie (Glasgow) and Juhani Suksi (Helsinki) for USD analyses. Both have given positive responses and possible samples for analyses are at present being checked.

4.9 Fe-oxides in fractures

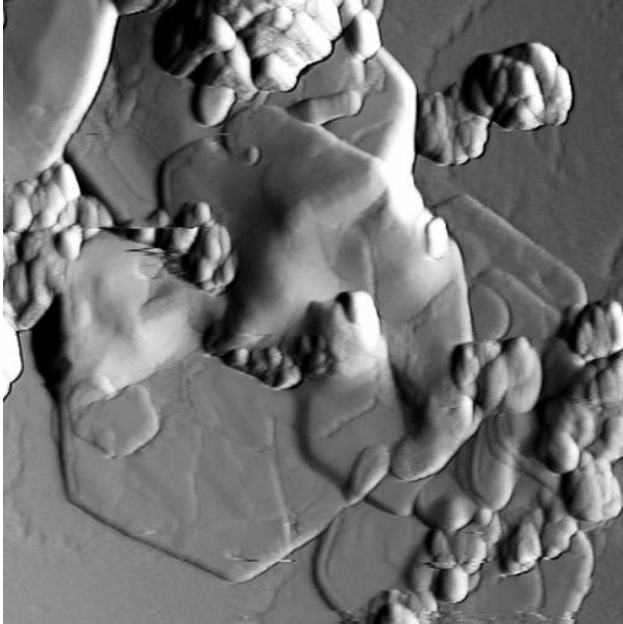

*Atomic Force Microscopy image of green rust sulphate.
Image is 2.5 x 2.5 microns*

Proof of reducing conditions at repository depth is fundamental for the safety assessment of radioactive waste disposals. Fe(II) - minerals are common in the bedrock and along fracture pathways and constitute a considerable reducing capacity together with the organic processes. Another area of interest is the radionuclide retention capacity provided by Fe-oxides and -oxyhydroxides in terms of sorption capacity and immobilisation.

The basic idea of the project is to examine Fe-oxide fracture linings, in order to explore for suitable palaeo-indicators for their formation conditions, while at the same time learning about the behaviour of trace component uptake in general, both from the natural material as well as through testing of behaviour in controlled parametric studies in the laboratory.

Achievements

The three year project on Fe-oxides started late autumn 2003. A one day Fe-oxide/redox seminar was held at SKB in March and the documentation from the seminar has been published. In the Fe-oxide project, promising results have been obtained when using Mössbauer analyses combined with Fe-isotope analyses in order to separate potentially low temperature (less crystalline) Fe-oxides from hematite (hydrothermal) and Fe-oxides emanating from Fe in the drilling equipment. The advances in the green rust study indicate possibility for trace metal (and radionuclide) uptake and potentially mobilisation/immobilisation related to the green rust phases. The writing of a progress report for this first phase of the project is on-going.

During this quarter, planning for the co-operation with the Spanish group at Enviro in Barcelona that will perform modelling of Fe(III)/Fe(II) species in natural groundwater systems has been going on. An outline for the planned work during the next two years is available and will put into an activity plan.

5 Äspö facility

An important part of the Äspö facility is the administration, operation, and maintenance of instruments as well as development of investigation methods. Other issues are to keep the stationary hydro monitoring system (HMS) continuously available and to carry out the programme for monitoring of groundwater head and flow and the programme for monitoring of groundwater chemistry.

5.1 Facility operation

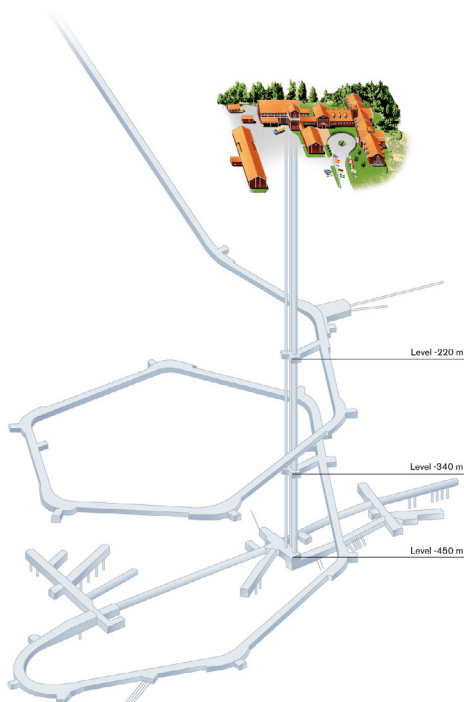

The main goal for the operation of the facility is to provide a safe and environmentally correct facility for everybody working or visiting the Äspö HRL.

This includes preventative and remedy maintenance in order to withhold high availability in all systems as drainage, electrical power, ventilation, alarm and communications in the Hard Rock Laboratory.

Achievements

Maintenance and operation of the above and underground facilities are running as well as improvements of the safety and working environment. The availability of the facility systems has been high during the second quarter.

The development and testing of an automatic registration and object-monitoring system is in progress. The system is based on radio frequency identification system for which a mobile pilot installation is tested. During this quarter a data server has been installed and the software has been developed. In addition, zones for passage control have been installed at different places (e.g. the tunnel entrance and the lift to the underground laboratory) for the three operation tests that will start after the vacations.

The data network with a system for administration including a server for storage of all experimental data, and a separated system for supervision of facilities has been functioning well. Baslab (located in Clab) are not yet included in the data network.

5.2 Hydro Monitoring System

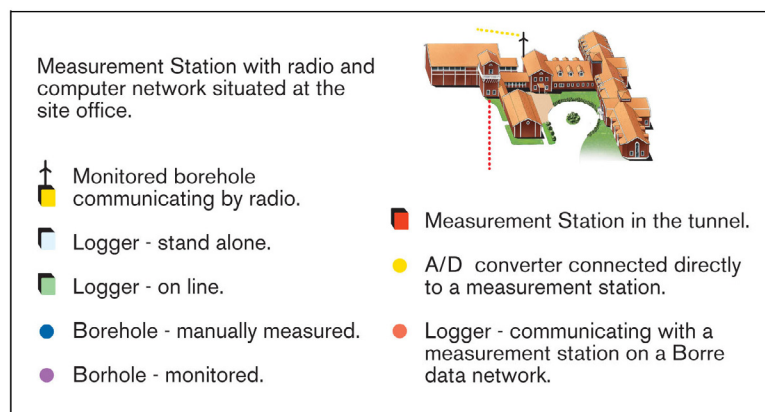
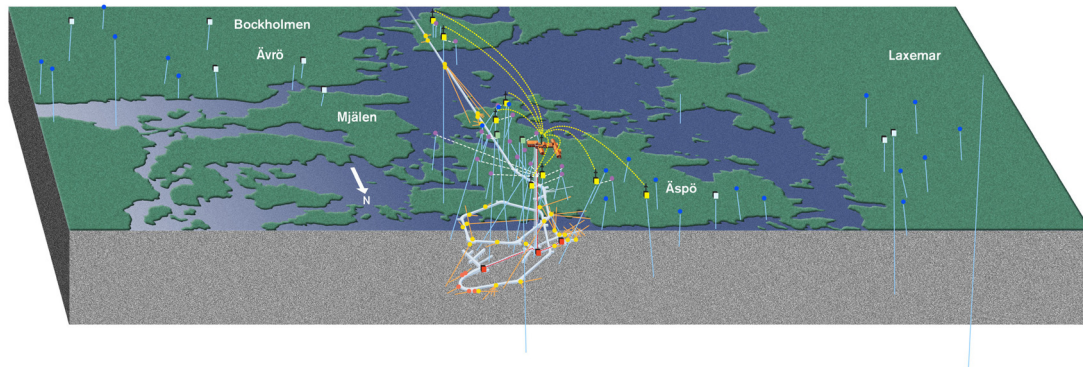

The computerised Hydro Monitoring System (HMS), is a network of boreholes and measurement stations where e.g. data of groundwater head, salinity, electrical conductivity, Eh and pH are collected on-line. The data are recorded by more than 400 transducers installed in boreholes on Äspö as well as in boreholes located in the tunnel. All data are transmitted to the main office at Äspö, by radio or modems. Weekly quality controls of preliminary groundwater head data are performed. Absolute calibration of data is performed three to four times per year. This work involves comparison with groundwater levels checked manually in percussion drilled boreholes and in core drilled boreholes. The scope of maintaining such a monitoring network has scientific as well as legal grounds.

Achievements

The system has been performing well. However, improvements are continuously made on the monitoring system to increase the performance of the system. The calibrations of groundwater head data, that were made 14-17 March, show good correspondence in groundwater levels. No new calibrations have been performed during this quarter.

5.3 Programme for monitoring of groundwater head and flow



The monitoring of water levels in surface based boreholes started in 1987. The tunnel excavation started in October 1990 and the first groundwater head (pressure) measurements from tunnel based boreholes were performed in March 1992.

The monitoring is administrated by the computerised hydro monitoring system (HMS), comprising a network of boreholes of which many are equipped with hydraulically inflatable packers, measuring the pressure by means of transducers. Manual levelling is also obtained from the surface boreholes on a regular basis.

Water seeping through the tunnel walls is diverted to trenches and further to 21 weirs where the flow is measured.

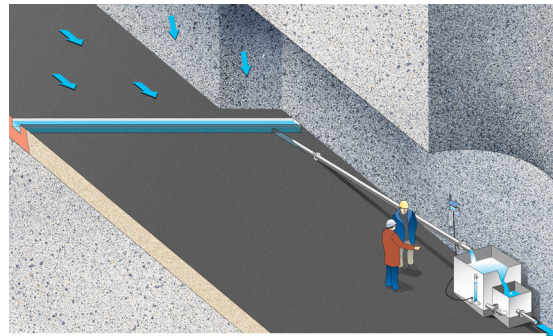

Achievements

The monitoring points from the previous year have been maintained. The system will continue to support the experiments undertaken and meet the requirements stipulated by the water rights court. A report describing instrumentation, measurement methods, and summarising the monitoring during 2004 is in progress.

5.4 Programme for monitoring of groundwater chemistry

During the Construction Phase of the Äspö HRL, different types of water samples were collected and analysed with the purpose of monitoring the groundwater chemistry and its evolution as the construction proceeded. At the beginning of the Operational Phase, sampling was replaced by a groundwater chemistry monitoring programme, aiming at a sufficient cover of the hydrogeochemical conditions with respect to time and space within the Äspö HRL. This programme is designed to provide information to determine where, within the rock mass, the hydrogeochemical changes are taking place and at what time stationary conditions are established.

Achievements

The annual water sampling campaign is in the same way as earlier years scheduled to take place in September – October. The previous sampling campaign took place in September 2004 and the results from the sampling were published in May in a technical document.

5.5 Information and public relations



SKB operates three facilities in the Oskarshamn municipality: Äspö HRL, Central interim storage facility for spent nuclear fuel (Clab) and Canister Laboratory. In 2002 SKB began site investigations at Oskarshamn and Östhammar.

The main goal for the information and public relations group at Äspö HRL, is to in co-operation with other departments at SKB, present information about SKB and its activities and facilities.

Achievements

SKB's facilities have been visited by 12 930 persons during the first six months 2005.

SKB facility	Number of visitors January - June 2005
Clab	1 130
Canister Laboratory	1 698
Äspö Hard Rock Laboratory	281
Äspö Nature Path	4 561

The Äspö day took place the 29th of May and about 200 visitors came. The summer activities with an increased number of guided tours to the exhibition "Urberg 500" started in the end of June and continued until the end of August. 2 500 visitors came! Four summer guides have been employed to support the information group during the summer. SKB was represented by the information group at the music festival in Hultsfred in June.

6 International co-operation

Seven organisations from six countries participate in the Äspö HRL co-operation during 2005. OPG (Canada) joined the cooperation during 2004.

Several of these organisations are participating in the two Äspö Task Forces on: (a) Modelling of Groundwater Flow and Transport of Solutes, which is a forum for co-operation in the area of conceptual and numerical modelling of groundwater flow and solute transport in fractured rock, and (b) THMC modelling of Engineered Barrier Systems, which is a forum for code development on THMC processes taking place in a bentonite buffer and gas migration through a buffer. Two additional organisations, Rawra (Czech Republic) and Nagra (Switzerland), participate in the Task Force on Engineered Barrier Systems.

Projects in the Äspö HRL during 2005	Andra	BMWA	Enresa	CRIEPI	JNC	OPG	Posiva	Nagra	Rawra
Technology									
Prototype Repository	X	X			X		X		
Backfill and Plug Test									
Long Term Test of Buffer Material							X		
Cleaning and sealing of investigation boreholes							X		
Injection grout for deep repositories							X		
KBS-3 method with horizontal emplacement							X		
Large Scale Gas Injection Test	X	X				X			
Temperature Buffer Test	X	X	X						
Task Force on Engineered Barrier Systems	X	X		X		X	X	X	X
Geo-science									
Äspö Pillar Stability Experiment						X	X		
Natural barriers									
Tracer Retention Understanding Experiments	X				X		X		
Long Term Diffusion Experiment						X			
Radionuclide Retention Project		X							
Colloid Project		X					X		
Microbe Project		X							
Matrix Fluid Chemistry									
Task Force on Modelling of Groundwater Flow and Transport of Solutes	X			X	X		X		
Participating organisations:									
Agence nationale pour la gestion des déchets radioactifs, Andra, France									
Bundesministerium für Wirtschaft und Arbeit, BMWA, Germany									
Empresa Nacional de Residuos Radiactivos, Enresa, Spain									
Central Research Institute of the Electronic Power Industry, CRIEPI, Japan									
Japan Nuclear Cycle Development Institute, JNC, Japan									
Nationale Genossenschaft für die Lagerung Radioaktiver Abfälle, Nagra, Switzerland									
Ontario Power Generation Inc., OPG, Canada									
Posiva Oy, Finland									
Radioactive Waste Repository Authority, Rawra, Czech Republic									

7 Environmental research

7.1 Äspö Research School

Kalmar University's Research School in Environmental Science at Äspö HRL, called Äspö Research School, started in October, 2002. This School is the result of an agreement between SKB and Kalmar University. It combines two important regional resources, i.e. Äspö HRL and Kalmar University's Environmental Science Section. The activity within the School will lead to: (a) development of new scientific knowledge, (b) increase of geo and environmental scientific competence in the region and (c) utilisation of the Äspö HRL for environmental research. Currently the scientific team consists of a professor of Environmental geology (Dr. Mats Åström), three assistant supervisors and six Ph.D. students. The research activity focuses on biogeochemical systems, in particular in the identification and quantification of dispersion and transport mechanisms of contaminants (mainly metals) in and between soils, sediments, water, biota and upper crystalline bedrock. In addition to financial support from SKB and University of Kalmar, the School receives funding from the city of Oskarshamn.

Achievements

There are currently a variety of research activities at sites outside Äspö HRL. These activities have resulted in several scientific publications.

8 Documentation

During the period April – June 2005, the following reports have been published and distributed.

8.1 Äspö International Progress Reports

Berglund J, Curtis P, Eliasson T, Olsson T, Starzec P, Tullborg E-L, 2003.

Update of the geological model 2002.

IPR-03-34, Svensk Kärnbränslehantering AB

Vidstrand P, 2003. Update of the hydrogeological model 2002.

IPR-03-35, Svensk Kärnbränslehantering AB

Laaksoharju M, Gurban I, 2003. Update of the hydrogeochemical model 2002.

IPR-03-36, Svensk Kärnbränslehantering AB

Hakami H, 2003. Update of the rock mechanical model 2002.

IPR-03-37, Svensk Kärnbränslehantering AB

Pusch R, 2004. Prototype Repository. Comparison of results from THMCB modelling of buffer, backfill and rock with measured data from Prototype Repository D-35.

IPR-04-11, Svensk Kärnbränslehantering AB

Andersson P, Byegård J, Nordqvist R, Wass E, 2004. TRUE Block Scale continuation project. BS2B tracer tests with sorbing tracers - experimental results and preliminary evaluation.

IPR-05-01, Svensk Kärnbränslehantering AB

Forsmark T, Rhén I, 2005. Prototype Repository. Hydraulic tests and deformation measurements during operation phase, Test campaign 4, single hole tests.

IPR-05-02, Svensk Kärnbränslehantering AB

Forsmark T, Rhén I, 2005. Prototype Repository. Hydrogeology - Diaper measurements in DA3551G01 and DA3545G01. Flow measurements in section II and tunnel G, past grouting activities.

IPR-05-03, Svensk Kärnbränslehantering AB

Alm P, Forsmark T, Rhén I, 2005. Prototype Repository. Installations for measurements of flow into tunnels, water pressure in rock and hydromechanical responses in boreholes during operation phase.

IPR-05-04, Svensk Kärnbränslehantering AB

Goudarzi R, Åkesson M, Hökmark H, 2005. Temperature Buffer Test. Sensors data report (Period: 030326-050101) Report No:5.

IPR-05-06, Svensk Kärnbränslehantering AB

Äspö Hard Rock Laboratory. Status Report. October - December 2004.
IPR-05-09, Svensk Kärnbränslehantering AB

Gröhn S, Andersson P, Wass E, 2005. Prototype Repository. Tracer dilution tests during operation phase, test campaign 1.
IPR-05-10, Svensk Kärnbränslehantering AB

Johannesson Lars-Erik, 2005. Prototype Repository. Laboratory tests on the backfill material in the Prototype Repository.
IPR-05-11, Svensk Kärnbränslehantering AB

Goudarzi R, Johannesson L-E, Börgesson L., 2005. Backfill and Plug test. Sensors data report (Period 990601-050101) Report No:10.
IPR-05-12, Svensk Kärnbränslehantering AB

Goudarzi R, Johannesson L-E, 2005. Prototype Repository. Sensors data report (Period: 010917-041201). Report No:12.
IPR-05-13, Svensk Kärnbränslehantering AB

Äspö Hard Rock Laboratory. Planning Report for 2005.
IPR-05-14, Svensk Kärnbränslehantering AB

Goudarzi R, Börgesson L, Röshoff K, Edelman M, 2005. Canister Retrieval Test. Sensors data report (Period 001026-050501) Report No:10.
IPR-05-15, Svensk Kärnbränslehantering AB

Äspö Hard Rock Laboratory. Status Report. January - March 2005.
IPR-05-16, Svensk Kärnbränslehantering AB

8.2 Technical Documents and International Technical Documents

3 Technical Documents have been published during the second quarter 2005.

9 References

Dershowitz W, Winberg A, Hermansson J, Byegård J, Tullborg E-L, Andersson P, Mazurek M, 2003. Äspö Hard Rock Laboratory. Äspö Task Force on modelling of groundwater flow and transport of solutes. Task 6c. A semi-synthetic model of block scale conductive structures at the Äspö HRL. IPR-03-13, Svensk Kärnbränslehantering AB

Goudarzi R, Börgesson L, Röshoff K, Edelman M, 2005a. Canister Retrieval Test. Sensors data report (Period: 001026-050501). Report No: 10. IPR-05-15, Svensk Kärnbränslehantering AB

Goudarzi R, Johannesson L-E, Börgesson L, 2005b. Backfill and Plug test. Sensors data report (Period 990601-050101) Report No: 10. IPR-05-12, Svensk Kärnbränslehantering AB

Goudarzi R, Åkesson M, Hökmark H, 2005c. Temperature Buffer Test. Sensors data report (Period: 030326-050101) Report No:5. IPR-05-06, Svensk Kärnbränslehantering AB

Goudarzi R, Johannesson L-E, 2005. Prototype Repository. Sensors data report (Period: 010917-041201). Report No:12. IPR-05-13, Svensk Kärnbränslehantering AB

Itasca Consulting Group, Inc., 2003. 3DEC – 3 Dimensional Distinct Element Code, User's Manual. Minneapolis: Itasca

Jansson M, Eriksen T E, 2005 (in print). Influence of water radiolysis on the mobilization of Tc(IV) in bentonite clay: Results from field experiments at Äspö. TR-04-22, Svensk Kärnbränslehantering AB

Mas Ivars D, 2004. Inflow into excavations – A coupled hydro-mechanical three-dimensional numerical study. Licentiate Thesis. KTH, Stockholm, Sweden.

Mas Ivars D, 2005. Äspö Pillar Stability Experiment. Hydromechanical data acquisition experiment at the APSE site. IPR-05-21, Svensk Kärnbränslehantering AB

SKB, 2004. RD&D-Programme 2004. Programme for research, development and demonstration of methods for the management and disposal of nuclear waste. TR-04-21, Svensk Kärnbränslehantering AB

SKB, 2005. Äspö Hard Rock Laboratory. Planning Report for 2005. IPR-05-14, Svensk Kärnbränslehantering AB

Smart N, Fennel P, Knowles G, 2005. The design of the mini-canisters - Design of Model Canister Experiment, Serco Assurance report SA/EIG/11080/C001, March 2005

Smellie J, Waberg N, Frape S, 2003. Matrix fluid chemistry experiment. Final report. June 1998-March 2003. TR-03-18, Svensk Kärnbränslehantering AB

Sundberg J, 2003. A strategy for the model development during site investigations version 1.0. R-03-10, Svensk Kärnbränslehantering AB